

RD-300GX

Owner's Manual

Roland®

Introduction

Thank you, and congratulations on your choice of the RD-300GX. To ensure that you obtain the maximum enjoyment and take full advantage of the RD-300GX's functionality, please read this owner's manual carefully.

About the Manual

You should first read the "Getting Ready" (p. 15) section of the owner's manual (this document). This explains how to connect the AC adaptor and turn on the power.

Conventions in this Manual

In order to explain the operations as clearly as possible, this manual uses the following conventions.

- Text enclosed in square brackets [] indicates the name of a button or a knob, such as the [EDIT] button.
- Lines that begin with **NOTE** or an asterisk * are cautionary statements that you must be sure to read.
- The numbers of pages that you can turn to for additional, related information are given like this: (p. * *).
- The explanations in this manual include illustrations that depict what should typically be shown by the display. Note, however, that your unit may incorporate a newer, enhanced version of the system (e.g., includes newer sounds), so what you actually see in the display may not always match what appears in the manual.

For the U.K.

IMPORTANT: THE WIRES IN THIS MAINS LEAD ARE COLOURED IN ACCORDANCE WITH THE FOLLOWING CODE.

BLUE: NEUTRAL
BROWN: LIVE

As the colours of the wires in the mains lead of this apparatus may not correspond with the coloured markings identifying the terminals in your plug, proceed as follows:

The wire which is coloured BLUE must be connected to the terminal which is marked with the letter N or coloured BLACK.

The wire which is coloured BROWN must be connected to the terminal which is marked with the letter L or coloured RED.

Under no circumstances must either of the above wires be connected to the earth terminal of a three pin plug.



Before using this unit, carefully read the sections entitled: "USING THE UNIT SAFELY" (p. 4), and "IMPORTANT NOTES" (p. 6). These sections provide important information concerning the proper operation of the unit. Additionally, in order to feel assured that you have gained a good grasp of every feature provided by your new unit, Owner's manual should be read in its entirety. The manual should be saved and kept on hand as a convenient reference.



Copyright © 2008 ROLAND CORPORATION

All rights reserved. No part of this publication may be reproduced in any form without the written permission of ROLAND CORPORATION.







USING THE UNIT SAFELY

INSTRUCTIONS FOR THE PREVENTION OF FIRE, ELECTRIC SHOCK, OR INJURY TO PERSONS

About  WARNING and  CAUTION Notices

 WARNING	Used for instructions intended to alert the user to the risk of death or severe injury should the unit be used improperly.
 CAUTION	Used for instructions intended to alert the user to the risk of injury or material damage should the unit be used improperly. * Material damage refers to damage or other adverse effects caused with respect to the home and all its furnishings, as well to domestic animals or pets.

About the Symbols

	The  symbol alerts the user to important instructions or warnings. The specific meaning of the symbol is determined by the design contained within the triangle. In the case of the symbol at left, it is used for general cautions, warnings, or alerts to danger.
	The  symbol alerts the user to items that must never be carried out (are forbidden). The specific thing that must not be done is indicated by the design contained within the circle. In the case of the symbol at left, it means that the unit must never be disassembled.
	The  symbol alerts the user to things that must be carried out. The specific thing that must be done is indicated by the design contained within the circle. In the case of the symbol at left, it means that the power-cord plug must be unplugged from the outlet.

ALWAYS OBSERVE THE FOLLOWING

WARNING

Do not disassemble or modify

Do not open (or modify in any way) the unit or its AC adaptor.



Do not repair or replace parts

Never attempt to repair this device or replace parts. If repair or part replacement should become necessary, you must contact your dealer or a Roland service center.



Do not use or store in the following types of locations

- Locations of extremely high temperature (such as in direct sunlight, near heating equipment, or on a device that generates heat)
- Near moisture (such as in a bathroom, near a sink, or on a wet floor) or in locations of high humidity
- Locations exposed to rain
- Locations of excessive dust
- Locations subject to heavy vibration



Use only a stand that is recommended

This unit should be used only with a stand that is recommended by Roland.



Do not place in an unstable location

When using the unit with a stand recommended by Roland, the stand must be carefully placed so it is level and sure to remain stable. If not using a stand, you still need to make sure that any location you choose for placing the unit provides a level surface that will properly support the unit, and keep it from wobbling.



WARNING

Connect the AC adaptor to an outlet of the correct voltage

Be sure to use only the AC adaptor supplied with the unit. Also, make sure the line voltage at the installation matches the input voltage specified on the AC adaptor's body. Other AC adaptors may use a different polarity, or be designed for a different voltage, so their use could result in damage, malfunction, or electric shock



Use only the included power cord

You must use only the power cord included with the device. Do not use the included power cord with any other device.



Do not bend the power cord or place heavy objects on it

Do not bend the power cord excessively, or place heavy objects on the power cord. Doing so will damage the power cord, and may cause short circuits or faulty connections, possibly resulting in fire or electrical shock.



Avoid extended use at high volume

This device, either by itself or used in conjunction with headphones, amps, and/or speakers, is capable of producing volume levels that can cause permanent hearing damage. If you experience impaired hearing or ringing in your ears, immediately stop using the device and consult a medical specialist.



Do not insert foreign objects

Never allow foreign objects (flammable objects, coins, wires, etc.) to enter this device. This can cause short circuits or other malfunctions.



⚠ WARNING

Turn off the power if an abnormality or malfunction occurs



Immediately turn the power off, remove the AC adaptor from the outlet, and contact your dealer or a service center to have the device serviced.

- The AC adaptor, the power-supply cord, or the plug has been damaged
- The device produces smoke or an unusual smell
- A foreign object enters the device, or liquid spills into the device
- The device becomes wet (by rain, etc.)
- An abnormality or malfunction occurs in the device

Do not allow children to use without supervision



In households with children, take particular care against tampering. If children are to use this device, they must be supervised or guided by an adult.

Do not drop or subject to strong impact



Do not drop this device or subject it to strong impact.

Do not share an outlet with an unreasonable number of other devices



Do not connect excessive numbers of electrical devices to a single power outlet. In particular, when using a power strip, exceeding the rated capacity (watts/amps) of the power strip may cause heat to be generated, possibly melting the cable.

Do not use overseas



If you wish to use this device overseas, please contact your dealer or a service center.

Do not use a CD-ROM in an audio CD player or DVD player



If you attempt to play back a CD-ROM in a conventional audio CD player or DVD player, the resulting high volume may damage your hearing or your speakers.

Do not place containers of water on the device



Do not place containers of water (such as a flower vase) or drinks on the device. Nor should you place containers of insecticide, perfume, alcoholic liquids, nail polish, or spray cans on the device. Liquids that spill into the device may cause it to malfunction, and may cause short circuits or faulty operation.

⚠ CAUTION

Place in a well ventilated location



When using this device and the AC adaptor, ensure that it is placed in a well ventilated location.

Use only the specified stands



This (RD-300GX) for use only with Roland stand KS-12 or KS-18Z. Use with other stand is capable of resulting in instability causing possible injury.

⚠ CAUTION

Grasp the plug when connecting or disconnecting the power cord



Always grasp only the plug on the AC adaptor cord when plugging into, or unplugging from, an outlet or this unit.

Periodically wipe the dust off the AC adaptor plug



At regular intervals, you should unplug the AC adaptor and clean it by using a dry cloth to wipe all dust and other accumulations away from its prongs. Also, disconnect the power plug from the power outlet whenever the unit is to remain unused for an extended period of time. Any accumulation of dust between the power plug and the power outlet can result in poor insulation and lead to fire.

Manage cables for safety



Ensure that the connected cables are organized and managed in a safe manner. In particular, place the cables out of reach of children.

Do not stand or place heavy objects on this device



Do not stand on this device, or place heavy objects on it.

Do not connect or disconnect the AC adaptor with wet hands



Never handle the AC adaptor or its plugs with wet hands when plugging into, or unplugging from, an outlet or this unit.

Cautions when moving this device



When moving this device, please check the following cautions. Then, make sure that at least two persons work together in lifting and carrying the device, all the while making sure to keep it level. When doing so, be careful not to pinch your hands or drop the device on your feet.

- Disconnect the power cord.
- Disconnect external devices.

Unplug the AC adaptor from the AC outlet before cleaning



Before cleaning the unit, turn off the power and unplug the AC adaptor from the outlet (p. 16).

If there is a possibility of lightning strike, disconnect the AC adaptor from the AC outlet



Whenever you suspect the possibility of lightning in your area, disconnect the AC adaptor from the outlet.

Keep small items out of the reach of children



Should you remove the screw of ground terminal, keep it in a safe place out of children's reach, so there is no chance of it being swallowed accidentally.

Important Notes

Power Supply

- Do not connect this device to the same electrical outlet as an inverter-controlled device such as a refrigerator, microwave oven, or air conditioner, or a device that contains an electric motor. Depending on how the other device is used, power supply noise could cause this device to malfunction or produce noise. If it is not practical to use a separate electrical outlet, please connect this device via a power supply noise filter.
- The AC adaptor will begin to generate heat after long hours of consecutive use. This is normal, and is not a cause for concern.
- Before you make connections, you must switch off the power on all devices to prevent malfunction and/or speaker damage.

Location

- If this device is placed near devices that contain large transformers, such as power amps, hum may be induced in this device. If this occurs, move this device farther away or change its orientation.
- If this device is operated near a television or radio, color distortion may be seen in the television screen or noise may be heard from the radio. If this occurs, move this device farther away.
- Keep your cell phone powered off or at a sufficient distance from this device. If a cell phone is nearby, noise may be heard when a call is received or initiated, or during conversation.
- Do not expose the unit to direct sunlight, place it near devices that radiate heat, leave it inside an enclosed vehicle, or otherwise subject it to temperature extremes. Excessive heat can deform or discolor the unit.
- If you move this device between locations of radically different temperature or humidity, water droplets (condensation) may form inside the device. Using the device in this condition will cause malfunctions, so please allow several hours for the condensation to disappear before you use the device.
- Do not leave objects on top of the keyboard. This can cause malfunctions such as failure to sound.
- Depending on the material and temperature of the surface on which you place the unit, its rubber feet may discolor or mar the surface.
You can place a piece of felt or cloth under the rubber feet to prevent this from happening. If you do so, please make sure that the unit will not slip or move accidentally.

Care

- For everyday cleaning wipe the unit with a soft, dry cloth or one that has been slightly dampened with water. To remove stubborn dirt, use a cloth impregnated with a mild, non-abrasive detergent. Afterwards, be sure to wipe the unit thoroughly with a soft, dry cloth.
- If water droplets should adhere to this device, immediately wipe them off using a soft dry cloth.
- Do not use solvents such as benzene, thinner, or alcohol, since these can cause deformation or color change.

Servicing

- If you return this device for servicing, the contents of memory may be lost. Please store important contents on a USB memory, or make a note of the contents. We take utmost care to preserve the contents of memory when performing service, but there may be cases when the stored content cannot be recovered because the memory section has malfunctioned. Please be aware that we cannot accept responsibility for the recovery of lost memory content or for any consequences of such loss.

Other Cautions

- Stored content may be lost due to a malfunction of the device or because of inadvertent operation. You should back up important content on a USB memory as a safeguard against such loss.
- We cannot accept responsibility for the recovery of any content lost from internal memory or USB memory, or for the consequences of such loss.
- Do not apply excessive force to the buttons, knobs, or input/output jacks, since this may cause malfunctions.
- Never strike or apply strong pressure to the display.
- When connecting or disconnecting cables, grasp the plug (not the cable) to prevent short circuits or broken connections.
- Please enjoy your music in ways that do not inconvenience other people nearby, and pay particular attention to the volume at nighttime. Using headphones will allow you to enjoy music without having to be concerned about others.
- When you need to transport the unit, package it in the box (including padding) that it came in, if possible. Otherwise, you will need to use equivalent packaging materials.
- Use only the specified expression pedal (EV-5/7; available separately). Connecting a pedal made by a different manufacturer may cause this device to malfunction.

USB Memory Handling

(Using USB Memory)

- When connecting USB memory, firmly insert it all the way in.
- Do not touch the pins of the USB memory connector, or allow them to become dirty.
- USB memory is made using high-precision electronic components, so please observe the following points when handling it.
 - To prevent damage from static electrical charges, discharge any static electricity that might be present in your body before handling USB memory.
 - Do not touch the terminals with your fingers or any metal object.
 - Do not bend or drop USB memory, or subject it to strong impact.
 - Do not leave USB memory in direct sunlight or in locations such as a closed-up automobile. (Storage temperature: 0–50 degrees C)
 - Do not allow USB memory to become wet.
 - Do not disassemble or modify USB memory.
- When connecting USB memory, position it horizontally with the USB memory connector and insert it without using excessive force. The USB memory connector may be damaged if you use excessive force when inserting USB memory.
- Do not insert anything other than USB memory (e.g., wire, coins, other types of device) into the USB memory connector. Doing so will damage the USB memory connector.
- Do not apply excessive force to the connected USB memory.
- If you will not be using USB memory for an extended period of time, close the USB memory cover.

CD Handling

- When handling the discs, please observe the following.
 - Do not touch the encoded surface of the disc.
 - Do not use in dusty areas.
 - Do not leave the disc in direct sunlight or an enclosed vehicle.
- Do not touch or scratch the recording surface of a CD. Doing so may render the data unreadable. If a CD becomes soiled, clean it using a commercially available CD cleaner.
- Keep the disc in the case.
- Do not keep the disc in the CD drive for a long time.
- Do not put a sticker on the label of the disc.
- Wipe the disc with a soft and dry cloth radially from inside to outside. Do not wipe along circumference.

- Do not use benzine, record cleaner spray or solvents of any kind.
- Do not bend the disc. Bending discs may prevent proper reading and writing of data, and may further result in malfunction.

Floppy Disk Handling

(Using Optional Floppy Disk Drive)

- Floppy disks contain a plastic disk with a thin coating of magnetic storage medium. Microscopic precision is required to enable storage of large amounts of data on such a small surface area. To preserve their integrity, please observe the following when handling floppy disks:
 - Never touch the magnetic medium inside the disk.
 - Do not use or store floppy disks in dirty or dusty areas.
 - Do not subject floppy disks to temperature extremes (e.g., direct sunlight in an enclosed vehicle). Recommended temperature range: 10–50 degrees C (50–122 degrees F).
 - Do not expose floppy disks to strong magnetic fields, such as those generated by loudspeakers.
- Floppy disks have a “write protect” tab which can protect the disk from accidental erasure. It is recommended that the tab be kept in the PROTECT position, and moved to the WRITE position only when you wish to write new data onto the disk.

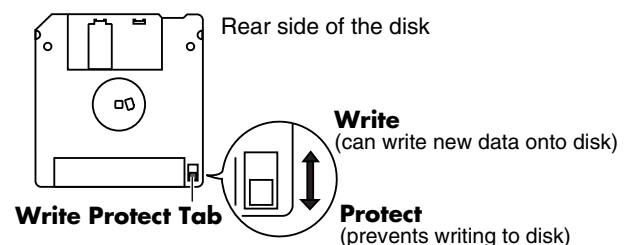

- The identification label should be firmly affixed to the disk. Should the label come loose while the disk is in the drive, it may be difficult to remove the disk.
- Store all disks in a safe place to avoid damaging them, and to protect them from dust, dirt, and other hazards. By using a dirty or dust-ridden disk, you risk damaging the disk, as well as causing the disk drive to malfunction.

* GS () is a registered trademark of Roland Corporation.

* All product names mentioned in this document are trademarks or registered trademarks of their respective owners.

* MPEG Layer-3 audio compression technology is licensed from Fraunhofer IIS Corporation and THOMSON Multimedia Corporation.

Contents

Introduction	3
About the Manual	3
USING THE UNIT SAFELY	4
Important Notes	6
Panel Descriptions	12
Front Panel	12
Rear Panel	14
Getting Ready	15
Placing the RD-300GX on a Stand	15
Connecting the AC Adaptor	16
Connecting the External Equipment to RD-300GX	17
Connecting Pedals	18
Turning the Power On and Off	19
Turning On the Power	19
Turning Off the Power	20
Adjusting the Volume	20
Adjusting the Display Contrast ([DISPLAY CONTRAST] Knob)	20
Using a USB Memory	21
Connecting a USB Memory	21
Overview of the RD-300GX	22
Basic Organization of the RD-300GX	22
Units of Sound	22
Basic Operation	23
Main Screens	23
About the Function Buttons	24
Editing a Value	24
Listening to the Demo (DEMO PLAY)	25
Performance	26
Piano Performances (ONE TOUCH [PIANO] Button)	26
Performing with a Variety of Tones (TONE SELECT Buttons)	27
Playing Multiple Tones with the Keyboard	28
Performing with Layered Tones ([DUAL] Button)	28
Playing Different Tones in Two Different Sections of the Keyboard ([SPLIT] Button)	29
Changing the Tone for a Zone (ZONE SELECT Button)	31
Adjusting the Volume Level for Individual Zones (ZONE LEVEL Sliders)	31
Transposing the Key of the Keyboard ([TRANSCOPE] Button)	32
Adding Reverberation to the Sound ([REVERB] Button)	33
Changing the Reverb Effect Type	33
Changing the Depth of Reverb Effect	34
Changing the Sound's Pitch in Real Time (Pitch Bend/Modulation Lever)	34
Adding Liveliness to the Sound ([SOUND CONTROL] Button)	35
Adjusting the Levels of Each Frequency Range (EQUALIZER Knobs)	36
Changing the Frequency of the Low and High Ranges	36

Using the Convenient Functions in Performances..... 37

Playing Rhythm ([SONG/RHYTHM] Button)	37
Changing Rhythm Pattern	38
Changing Rhythm Tempos.....	38
Changing Rhythm Volume	39
Playing Songs ([SONG/RHYTHM] Button).....	40
Changing Song Tempos.....	41
Fast-forwarding or Rewinding a Song	41
Performing with Audio Files ([AUDIO KEY] Button).....	42
Performing with Audio Files from USB Memory	42
Performing with Audio Files that are Built Into the RD-300GX.....	45
Adjusting the Volume of Audio Key	45
Changing Audio File Settings	46
Applying Effects to the Sound ([MULTI EFFECTS] Button)	47
Changing the Depth of Effect.....	47
Changing the Multi-effects Type	48
Changing the Undulation of the Organ Tone (Rotary Effect).....	48
Disabling the Buttons (Panel Lock).....	49
Selecting Stored Settings ([SETUP] Button).....	50
Storing Settings to Setups ([WRITE] Button)	51

Using the RD-300GX As a Master Keyboard 53

What's MIDI?	53
About MIDI Connectors.....	53
Connecting to External MIDI Sound Generators	54
Setting the MIDI Transmit Channel (MIDI OUT Channel)	55
Selecting Sounds on an External MIDI Device (MSB/LSB/PC)	56
Adjusting the Volume of Each Zone (External Zone)	57
Detailed Settings for Transmitted Parts ([EXTERNAL/INTERNAL] Button)	58
How to Make Settings	58
Adjusting the Volume and Pan (Vol/Pan)	58
Setting the Amount of Reverb and Chorus (Rev/Cho).....	58
Setting the Transposition for Each Individual Zone (Trs)	58
Setting the Key Range (KRL/KRU)	59

Making Detailed Settings for the ONE TOUCH Tones 60

Making Detailed Settings for the Piano Tones (Piano Designer)	60
Making the Settings.....	60
Selecting the Piano Sound (Tone)	60
Changing the Amount of Reverb Effect (Reverb Depth)	60
Opening/Closing the Piano Lid (Lid).....	60
Adjusting the Damper Noise (Damper Noise)	60
Adjusting the Resonance of the Aliquot Strings (Duplex Scale)	61
Adjusting the Resonant Sounds when the Keys are Pressed (String Resonance).....	61
Adjusting the String Resonance Produced when a Key is Released (Key Off Reso.).....	61
Adjusting the Sound of the Hammer Strike (Hammer Noise)	61
Precise Modification of Chord Sonorities (Stretch Tune).....	61

Changing the Key Touch (Key Touch/Ofst).....	62
Setting a Constant Volume Level in Response to the Playing Force (Velocity)	62
Changing the Timing of Sounds in Response to the Velocity (Velo Delay Sens).....	62
Changing How Volume Responds to the Velocity (Key Touch Mode).....	62
Detailed Settings for Each Function ([EDIT] Button).....	63
Setting Parameters.....	63
Parameters that can be Set.....	63
Making System Settings (System).....	64
Tuning to Other Instrument's Pitches (Master Tune).....	64
Adjusting the Volume (Master Volume).....	64
Using a Control Pedal to Switch Setups (SETUP Pedal Sft).....	64
Using Program Change Messages to Switch Setups (SETUP Ctrl Ch.).....	65
Making the Settings for the USB Driver (USB Driver)	65
Changing the USB Memory Setting (USB Memory Mode).....	65
Switching the Pedal's Polarity (Damper Polarity/Control Polarity)	65
Selecting the Indicator Mode (Indicator Mode).....	65
Selecting the Number of Parts (Part Mode)	66
Setting the Tuning Method (Temperament).....	66
Selecting the Keynote (Temperament Key)	66
Switching Between Reception of GM/GM2 System On and GS Reset (Rx GM Sys ON, Rx GS Reset)	67
Adjusting the Volume of Audio File Playback (Audio Volume)	67
Having Song Playback Stop when You Press a ONE TOUCH Button (Song Stop Mode).....	67
Setting the Keyboard Touch (Key Touch).....	67
Setup-Related Settings (Common)	68
Setting the Zone to which Multi Effects are Added (MFX Zone).....	68
Changing the Pedal Function (Ctrl Pedal Func).....	68
Assigning Functions to the [S1] [S2] Buttons (S1/S2 Func).....	68
Tone Settings (Tone Parameter)	69
Changing Tone Elements (Attack Time/Release Time/Cutoff Freq/Resonance/Decay Time).....	69
Setting the Amount of Reverb Applied to Each Tone (Reverb Amount)	69
Changing the Pitch (Coarse Tune/Fine Tune)	70
Changing the Bend Range (Bend Range)	70
Making the Settings for Each Zone Individually (Zone Parameter)	70
Setting the Transposition for Each Individual Zone (Transpose).....	70
Setting the Pan (Pan)	70
Turning the Controllers in Each Zone On and Off.....	71
Part On/Off (Part Switch).....	71
File Management (File).....	72
Saving a Setup File (Save SETUP).....	72
Calling Up Setup File (Load SETUP)	72
Deleting a Setup File (Delete SETUP)	73
Copying a Setup File (Copy SETUP)	74
Copying a Song (Copy SONG).....	74
Deleting a Song (Delete SONG)	75
Formatting Memory (Format).....	76

Settings Related to Song Playback (Song Function)	76
Selecting the Song Playback Method (Play Mode)	76
Changing the Key of the Song Playback (Playback Trans)	76
Performing Along with a Audio File (Center Cancel)	76
Utility Settings (Utility)	77
Transferring the RD-300GX's Settings to an External MIDI Device (Bulk Dump)	77
Restoring the Settings to the Factory Condition (Factory Reset)	77
Connecting External MIDI Devices	78
Recording RD-300GX Performances to an External MIDI Sequencer	78
Connecting to an External Sequencer	78
Settings for Recording (Rec Mode/Local Control)	78
Recording the Performance	79
Exiting Rec Mode	79
About the Local Switch	79
Playing the RD-300GX's Internal Sound Generator from an External MIDI Device	80
Making Connections	80
Selecting RD-300GX Sounds from an External MIDI Device	80
Switching Setups	80
Connecting to Your Computer	81
Connecting to a Computer via the USB MIDI Connector	81
About V-LINK	82
How to Use the V-LINK	82
Appendices	83
Troubleshooting	83
Error Messages/Other Messages	86
Error Messages	86
Other Messages	86
Effect List	87
Tone List	91
Rhythm Set List	94
Rhythm Pattern List	97
Setup List	98
Shortcut List	98
MIDI Implementation Chart	99
Main Specifications	100
Index	101

Panel Descriptions

Front Panel

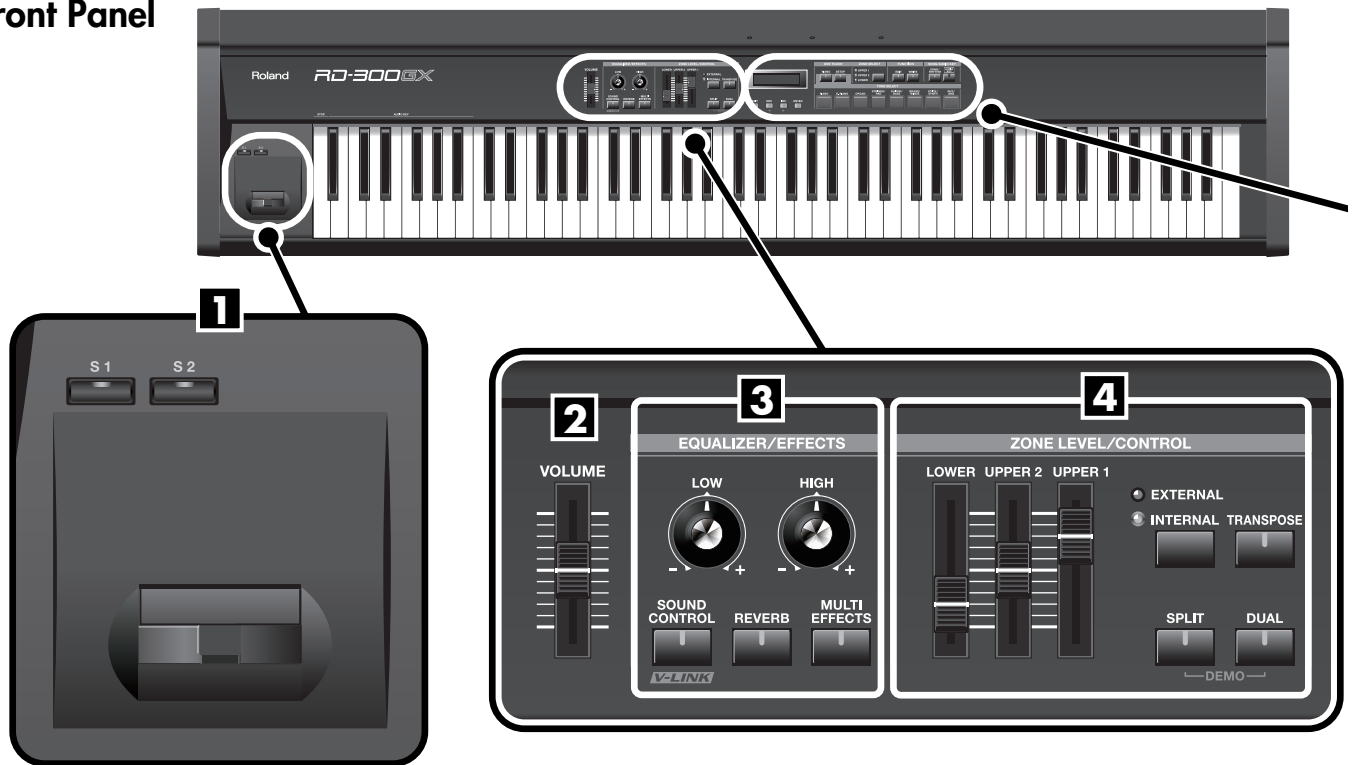

1. [S1] Button, [S2] Button

You can assign various functions to these buttons (p. 68). While performing, you can press these buttons to use the assigned functions.

Pitch Bend/Modulation Lever

This allows you to control pitch bend or apply vibrato (p. 34).

2. VOLUME Slider

Adjusts the overall volume that is output from the rear panel OUTPUT jacks, and PHONES jack (p. 20).

3. EQUALIZER/EFFECTS

[LOW] Knob

Adjusts the sound's low-frequency range (p. 36).

[HIGH] Knob

Adjusts the sound's high-frequency range (p. 36).

[SOUND CONTROL] **V-LINK** Button

Switching this on will reduce inconsistencies in the volume, and produce a more stable, consistent sound (p. 35). Switching this on lets you control external V-LINK compatible video equipment connected to the RD-300GX (p. 82).

[REVERB] Button

Switches the reverb on/off (p. 33).

[MULTI EFFECTS] Button

Switches the multi-effects on/off (p. 47).

4. ZONE LEVEL/CONTROL

ZONE LEVEL Sliders

Adjust the volume level for each Zone (p. 31).

If the "EXTERNAL" indicator is lit, these sliders control the volume of an external MIDI sound module (p. 57).

[EXTERNAL/INTERNAL] Button

Puts the RD-300GX in control of the external MIDI sound generator (p. 55).

[TRANSPOSE] Button

Sets the range of the keyboard to transposed (p. 32).

[SPLIT] Button

This button selects "Split mode," whereby the keyboard is divided into two regions, allowing you to play separate sounds with the right and left hands (p. 29).

In addition, you can listen to the demo songs by simultaneously pressing this button and the [DUAL] button (p. 25).

[DUAL] Button

Switches the RD-300GX to "Dual mode," which enables performances with two separate Tones layered together (p. 28).

In addition, you can listen to the demo songs by simultaneously pressing this button and the [SPLIT] button (p. 25).

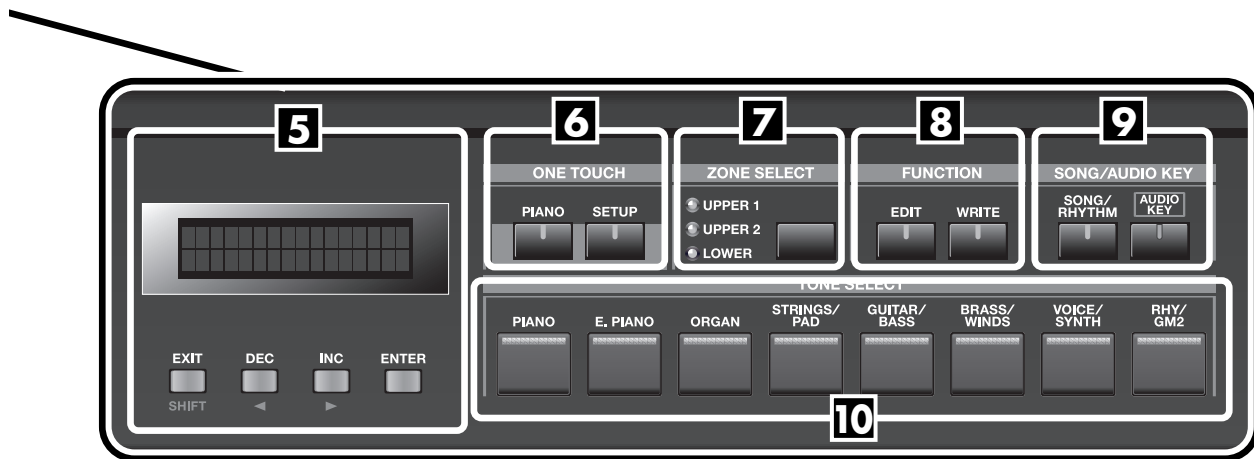

5. DISPLAY

This shows the Tone names and the values of various settings, etc.

[EXIT/SHIFT] Button

Pressed to return to a previous screen or to cancel a procedure that is in progress.

Additionally, this is pressed simultaneously with other buttons to execute various functions.

[DEC] Button, [INC] Button

These are used to modify values.

If you keep on holding down one button while pressing the other, the value change accelerates.

[ENTER] Button

This is used to finalize a value or execute an operation.

6. ONE TOUCH

[PIANO] Button

Selects the optimum settings for piano performances (p. 26).

[SETUP] Button

Calls up the stored settings (Setup) (p. 50).

7. ZONE SELECT Button

Selects the Zone for which the Tone is to be selected (p. 31).

ZONE SELECT Indicators

8. FUNCTION

[EDIT] Button

Press this button when you wish to adjust various settings (p. 63).

[WRITE] Button

Stores the current settings to Setup (p. 51).

This also stores the System settings (p. 64) and Piano Designer settings (p. 60).

9. SONG/AUDIO KEY

[SONG/RHYTHM] Button

Switches Song on/off (p. 40).

Switches Rhythm on/off (p. 37).

[AUDIO KEY] Button

Switches Audio Key on/off (p. 42).

10. TONE SELECT Buttons

Pressed to select Tones (p. 27).

Rear Panel

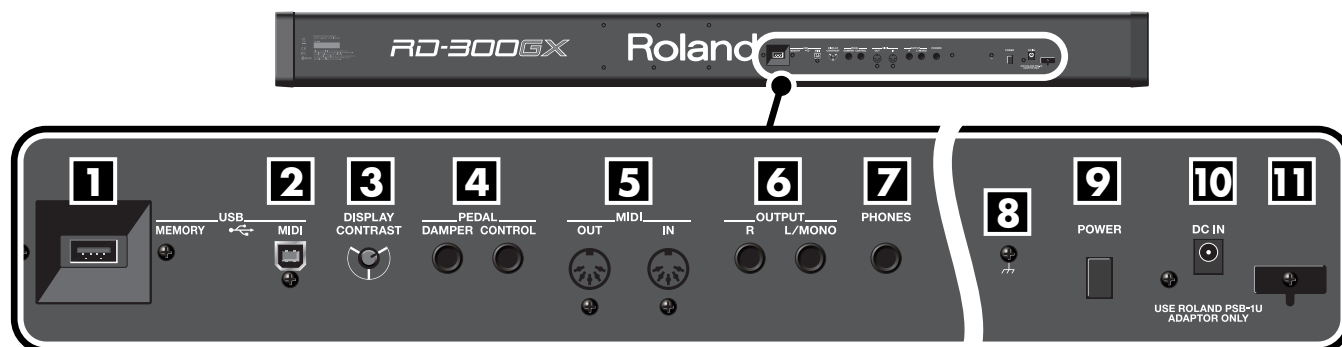

1. USB MEMORY Connector

Separately sold USB memory or a commercially available CD-ROM drive can be connected here (p. 21).

2. USB MIDI Connector

You can connect this to your computer so that it can exchange performance data with the RD-300GX (p. 81).

3. [DISPLAY CONTRAST] Knob

Adjusts the display's contrast (p. 20).

4. PEDAL Jacks (DAMPER, CONTROL)

Connecting the pedal switch (DP series) provided with the RD-300GX to the DAMPER jack allows you to use the switch as a damper pedal. (p. 18)

With a pedal connected to the CONTROL jack, you can then assign a variety of functions to the pedal (p. 68).

5. MIDI Connectors (IN, OUT)

Used for connecting external MIDI devices and for transmission of MIDI messages (p. 53, p. 78).

6. OUTPUT L (MONO)/R Jacks

Provide output of the audio signals. These are connected to an amp or other device. For monaural output use the L/MONO jack. (p. 17)

7. PHONES Jack

A set of headphones can be connected to this jack (p. 17). Even when headphones are connected, sound will still be output from the OUTPUT jacks.

8. Ground Terminal (p. 16)

9. [POWER] Switch

Switch turns the power on/off (p. 19).

10. DC IN Jack

Connect the included AC adaptor here (p. 16).

11. Cord Hook

Use this to fix in place the cord from the supplied AC adaptor (p. 16).

Getting Ready

Placing the RD-300GX on a Stand

If you place the RD-300GX on a stand, you must use the KS-12 or KS-18Z (sold separately). When placing the RD-300GX on the KS-12 or KS-18Z, place it in the position shown below.

NOTE Using the RD-300GX with any other stand may produce an unstable situation, possibly causing the instrument to fall or overturn, and resulting in injury or damage.

NOTE For details on how to assemble the stand, refer to the owner's manual that accompanied the stand.

If using the KS-18Z stand

- Adjust the stand to a level no higher than the fourth level from the bottom.
- Adjust the width of the stand to the maximum width.

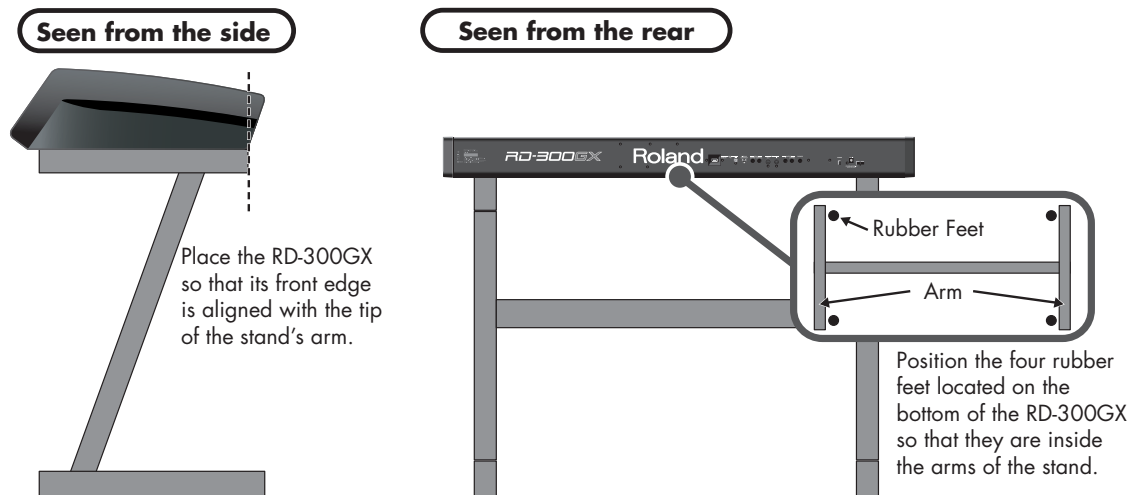

If using the KS-12 stand

- Position the stand so that its arms extend toward the performer.
- Adjust the stand to the sixth (842 mm) of the seven steps of width.

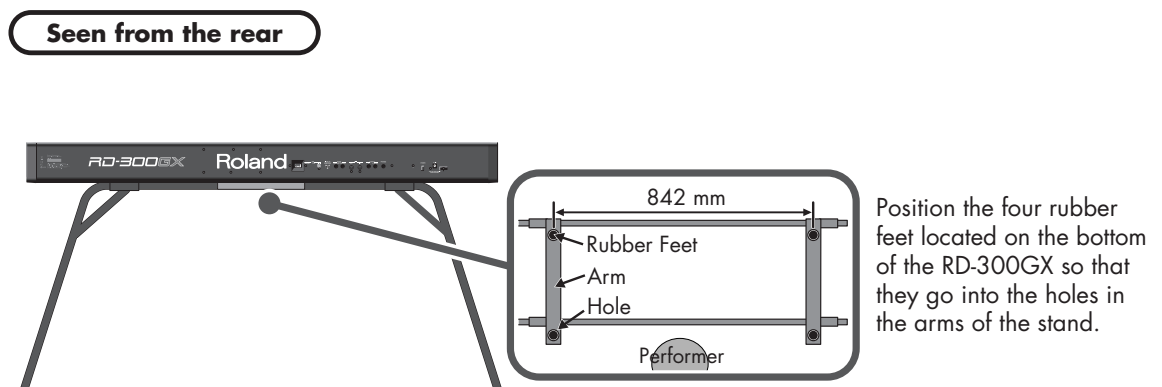

NOTE When placing the RD-300GX on the stand, be careful not to pinch your fingers between the instrument and the stand.

Connecting the AC Adaptor

1. Make sure that the [POWER] switch located at the left side of the keyboard is off (in the upward position).

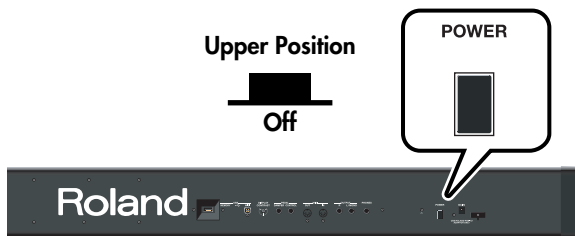

2. Move the VOLUME slider all the way down to minimize the volume.
3. Connect the supplied Power Cord to the supplied AC adaptor.

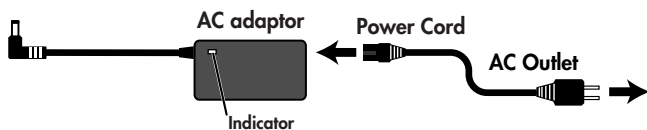

Place the AC adaptor so the side with the indicator (see illustration) faces upwards and the side with textual information faces downwards.

NOTE

The indicator will light when you plug the AC adaptor into an AC outlet.

4. Connect the AC adaptor to the RD-300GX's DC IN jack, and plug the power cord into an AC outlet.

5. Loop the AC adaptor cord around the cord hook to fasten it in place.

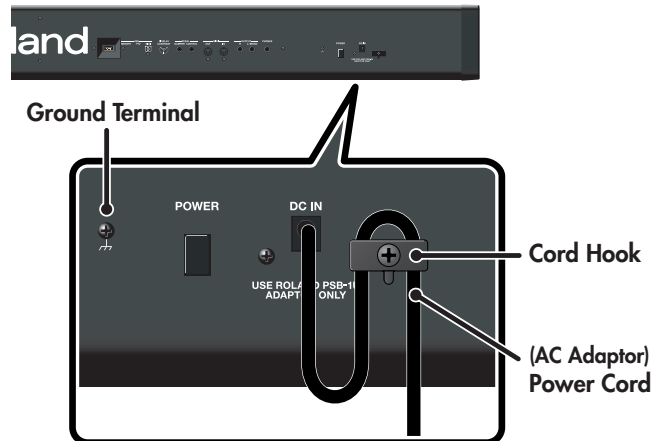

NOTE

To prevent the inadvertent disruption of power to your unit (should the plug be pulled out accidentally), and to avoid applying undue stress to the AC adaptor jack, anchor the power cord using the cord hook, as shown in the illustration. Even if the cord is fastened, strong tension applied to the cord may cause it to be damaged or broken. Be careful not to pull the cord accidentally, or to apply strong pressure to it.

NOTE

Depending on the circumstances of a particular setup, you may experience a discomforting sensation, or perceive that the surface feels gritty to the touch when you touch this device. This is due to an infinitesimal electrical charge, which is absolutely harmless. However, if you are concerned about this, connect the ground terminal (see figure) with an external ground. When the unit is grounded, a slight hum may occur, depending on the particulars of your installation. If you are unsure of the connection method, contact the nearest Roland Service Center, or an authorized Roland distributor, as listed on the "Information" page.

Unsuitable places for connection

- Water pipes (may result in shock or electrocution)
- Gas pipes (may result in fire or explosion)
- Telephone-line ground or lightning rod (may be dangerous in the event of lightning)

Connecting the External Equipment to RD-300GX

The RD-300GX is not equipped with an amplifier or speakers. In order to produce sound, you need to hook up audio equipment such as a monitor speaker or a stereo set, or use headphones.



Audio cables, USB cables, MIDI cables, headphones, expression pedals, and USB memory are not included. Consult your Roland dealer if you need to purchase accessories such as these.



To prevent malfunction and/or damage to speakers or other devices, always turn down the volume, and turn off the power on all devices before making any connections.

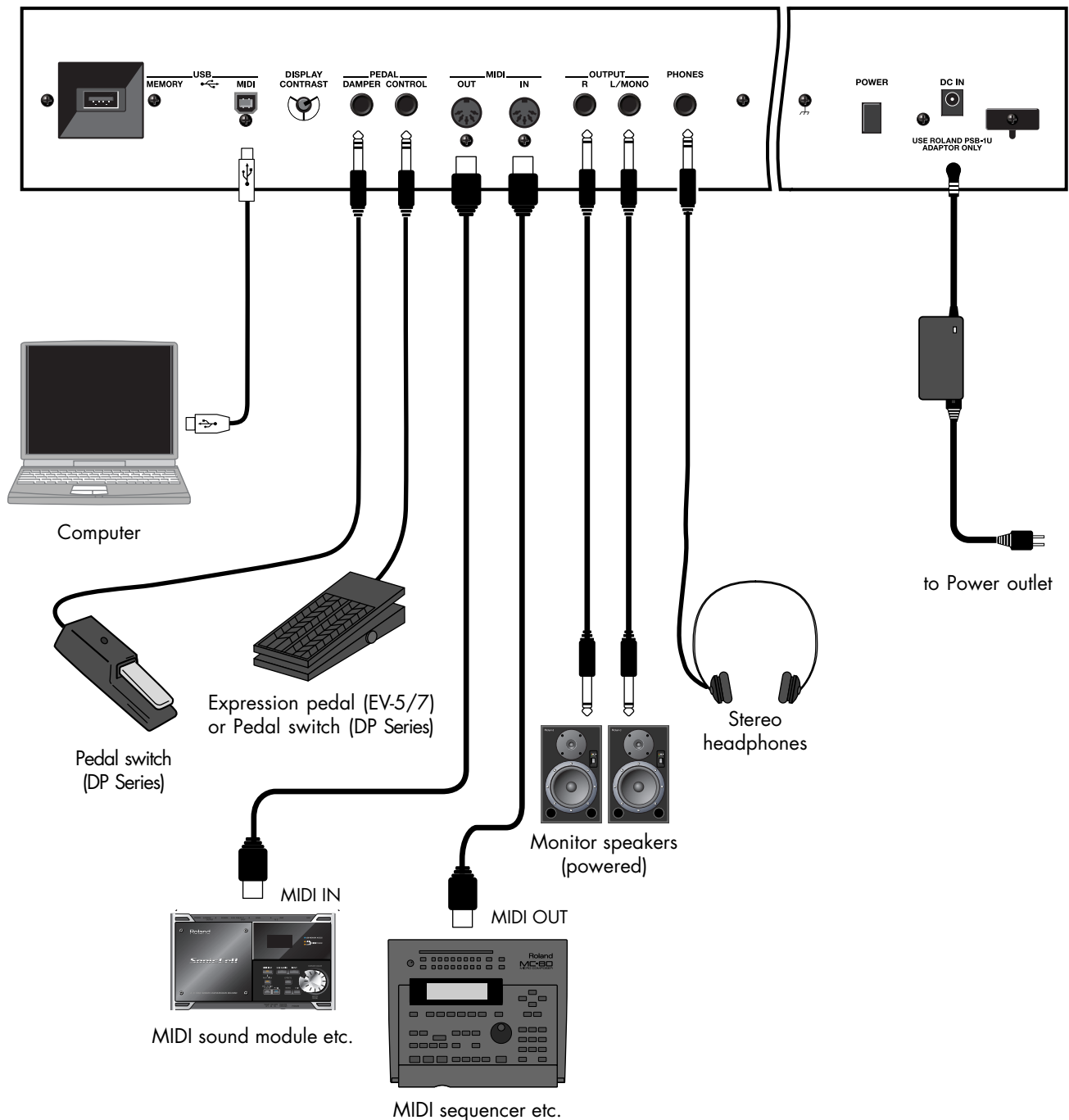

1. Before you begin making connections, confirm the following.

Is the volume level of the RD-300GX or connected amp turned all the way down?

Is the power to the RD-300GX or connected amp turned off?

2. Connect supplied AC adaptor to the DC IN of the RD-300GX, and plug the other end into an AC outlet.

3. Connect the RD-300GX and external devices.

Use audio cables to connect audio equipment, such as an amp or speakers.

Use MIDI cables to connect MIDI devices. Use USB cables to connect computer.

If you are using headphones, plug them into the PHONES jack.

Connect pedal switches or expression pedals as necessary.

NOTE Use Stereo headphones.

NOTE Use only the specified expression pedal (EV-5/7; sold separately). By connecting any other expression pedal, you risk causing malfunction and/or damage to the unit.

NOTE You can connect a floppy disk drive (sold separately) or a commercially available CD drive to the USB MEMORY connector (p. 14). You can use a floppy disk drive or CD drive to play back songs from a floppy disk or CD.

Connecting Pedals

Connect the pedal included with the RD-300GX to one of the PEDAL jacks.

When connected to the DAMPER jack, the pedal can be used as a damper pedal.

Connecting the pedal to the CONTROL jack allows you to assign a variety of functions to the pedal (p. 68).

NOTE Set the switch on the included pedal to "Continuous" when the pedal is connected.

Turning the Power On and Off

NOTE Once the connections have been completed, turn on power to your various devices in the order specified. By turning on devices in the wrong order, you risk causing malfunction and/or damage to speakers and other devices.

Turning On the Power

1. Before you turn on the power, use the **VOLUME** slider to minimize the volume.

Also completely turn down the volume of any connected audio device and other equipment.

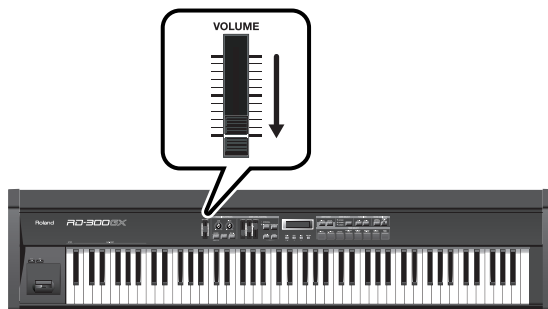

2. Press the **[POWER]** switch on the back of the RD-300GX to turn on the power.

The unit is powered up, and the display's backlighting comes on.



NOTE To prevent incorrect functioning of the Pitch Bend/Modulation Lever (p. 34), refrain from touching the lever while the power to the RD-300GX is turned on.

NOTE This unit is equipped with a protection circuit. A brief interval (a few seconds) after power up is required before the unit will operate normally.

NOTE In the unlikely event the power is turned off or cut off while Factory Reset (p. 77) is in progress, the data may become corrupted, and it may require additional time for the unit to start up the next time.

3. Turn on the power to connected external devices.

4. Adjust the volume of the connected external devices.

5. Adjust the RD-300GX's volume to obtain the proper volume level.

Turning Off the Power

1. Before you turn off the power, move the volume down all the way by moving the **VOLUME** slider.

Also completely turn down the volume of any connected audio device and other equipment.

2. Turn off the power to connected external devices.

3. Press the **[POWER]** switch on the back of the RD-300GX.

The power is switched off.

NOTE

If you need to turn off the power completely, first turn off the **[POWER]** switch, then unplug the power cord from the power outlet. Refer to "Power Supply" (p. 6).

Adjusting the Volume

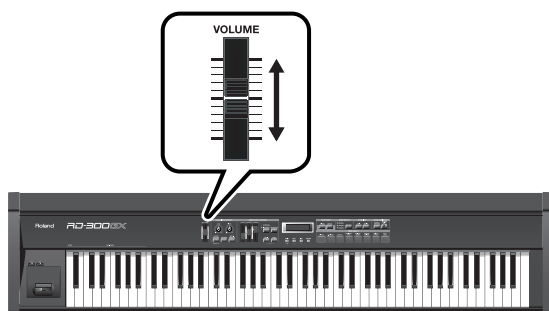

1. Adjust the volume using the **VOLUME** slider.

Move the slider up to increase the volume, or down to lower it.

Also adjust the volume of the connected devices to an appropriate level.

Adjusting the Display Contrast ([DISPLAY CONTRAST] Knob)

The characters in the display may be difficult to view immediately after turning on the power or after extended use; this may also be because of where and how the display is situated.

In such instances, adjust the display contrast by turning the **[DISPLAY CONTRAST]** knob on the rear panel.

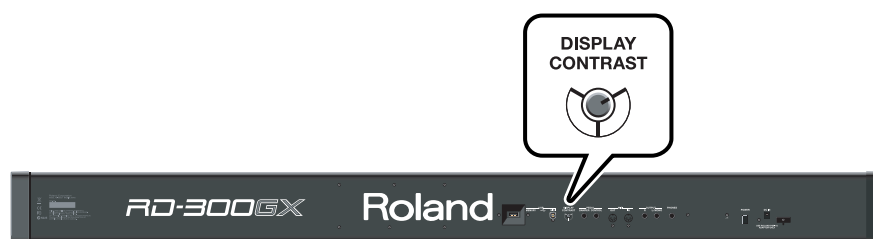

Using a USB Memory

You can copy Setup files and song files to separately sold USB memory for safekeeping. You can also play back SMF music files that's saved on USB memory (p. 40), or play audio files from USB memory (p. 42).



You can also use a separately sold floppy disk drive to copy data to a floppy disk. For details, refer to the owner's manual of your floppy disk drive.



Use USB memory and floppy disk drive available from Roland. Proper operation cannot be guaranteed if other USB device is used.

Connecting a USB Memory

1. Connect your USB memory to the USB MEMORY connector located on the RD-300GX's rear panel.

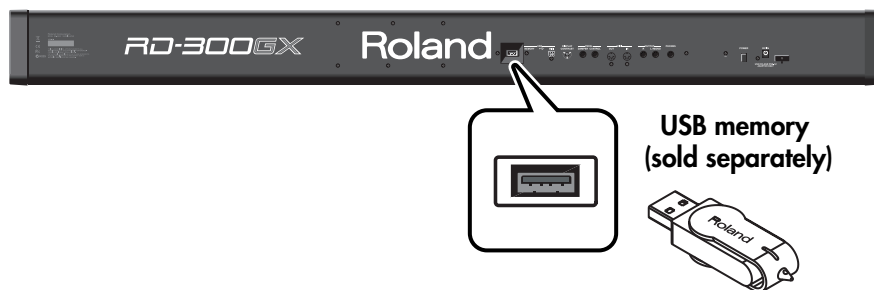

Carefully insert the USB memory all the way in—until it is firmly in place.



If you're using new USB memory, you must first initialize (format) it on the RD-300GX. For details, refer to "Formatting Memory (Format)" (p. 76).



You can also connect a commercially available CD drive or floppy disk drive (sold separately) to the USB MEMORY connector.

Overview of the RD-300GX

Basic Organization of the RD-300GX

The RD-300GX can be divided into two sections: a controller section and a sound generator section.

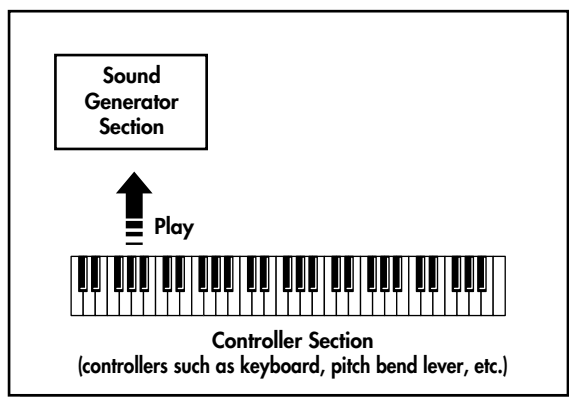

Controller Section

This section includes the keyboard, the Pitch Bend/Modulation lever, the panel knobs, the sliders, and any pedal connected to the rear panel. Actions such as pressing and releasing of keys on the keyboard, depressing a pedal, and so forth, are converted to MIDI messages and sent to the sound generator section, or to an external MIDI device.

Sound Generator Section

The sound generator section produces the sound. Here, MIDI messages received from the controller section or external MIDI device are converted to musical signals, which are then output as analog signals from the OUTPUT and PHONES jacks.

Units of Sound

When using the RD-300GX, you will notice that a variety of different categories come into play when working with sounds. What follows is a simple explanation of each sound category.

Tone

The individual sounds used when playing the RD-300GX are referred to as "Tones." Tones are assigned to each part. The Tones also include various groups of percussion instrument assembled into "Rhythm Sets." Each key (note number) of a Rhythm Set will produce a different percussion instrument.

Part

A sound generator of this type which can control multiple sounds using one device is referred to as a multitimbral sound generator. The RD-300GX contains a multitimbral sound generator capable of playing sixteen Tones simultaneously. "Parts" are where Tones that are created when the RD-300GX is used as a sound generator are assigned. Since different Tones can be assigned to each of the Parts and controlled individually, you can have multiple Tones play simultaneously, divide the keyboard into separate ranges and have different Tones sound in the different parts (Split), and enjoy playing ensemble performances.

The sixteen Parts played by the RD-300GX's internal sound generator are referred to as "Internal Parts."

Zone

The RD-300GX features three Parts (UPPER 1, UPPER 2, and LOWER) that you can use for freely controlling the Internal Parts with the RD-300GX's buttons and keyboard. These three Parts that are used for controlling the Internal Parts are collectively known as the "Internal Zone."

Furthermore, you can freely control external MIDI sound generators with the RD-300GX in the same manner as with the Internal Zone. You can likewise control the external MIDI sound generator with the three Parts (UPPER 1, UPPER 2, and LOWER), with this group of three Parts being referred to as the "External Zone." The external MIDI sound generator is assigned to these three Parts for control.

Basic Operation

Main Screens

ONE TOUCH Screen

When the ONE TOUCH [PIANO] button is pressed, setting the RD-300GX to the optimal status for Piano performances, this screen is displayed.

```
ONE TOUCH PIANO
Superior Grd
```

Tone Screen (Basic Screen)

The names of the Tones currently selected for the Internal Zone are displayed. This is the screen that is ordinarily displayed. You can change the Internal Zone (UPPER 1, UPPER 2, and LOWER) Tones.

```
UPPER1
001: Superior Grd
```

Setup Screen

The currently selected Setup is displayed (p. 50). You can have this screen displayed by pressing the ONE TOUCH [SETUP] button. You can change the Setups.

```
==== SETUP ====
Press [TONE]
```

Song Screen Rhythm Screen

When you press the [SONG/RHYTHM] button, the Song screen or Rhythm screen will appear.

In the Song screen, you can select and play songs (p. 40). You can also connect USB memory (sold separately) to the USB MEMORY connector and play SMF music files or audio files that you've saved in the USB memory.

```
*INT #=120 M: 1
000: Macho Blues
```

If SMF music file is selected, the measure number is shown in the upper right of the screen. If an audio file is selected, the playing time is shown in the upper right of the screen.

In the Rhythm screen, you can change Rhythm patterns, and the tempo (p. 37).

```
*RHY #=120
001: Piano R&B 1
```

Switching between the Rhythm screen and Song screen

1. While continuing to hold down the [EXIT/SHIFT] button, use the [DEC] [INC] buttons to move the cursor to the upper left of the screen.
2. The Rhythm screen will appear if you use the [DEC] [INC] buttons to select "RHY," and the Song screen will appear if you select "INT" or "USB."

Audio Key Screen

Pressing the [AUDIO KEY] button switches the RD-300GX to this screen.

You can perform while playing back audio files you've saved on USB memory (sold separately) (p. 42).

```
Press Key
Bb0 to B 1
```

External Screen

When the [EXTERNAL/INTERNAL] button is pressed, the EXTERNAL indicator lights up, and the RD-300GX switches to the mode enabling it to control an external MIDI sound generator. The status of this button determines whether the RD-300GX's buttons are used to control the Internal Zone (INTERNAL indicator lights up), or to control the External Zone (EXTERNAL indicator lights up). In addition, you can make detailed settings for the MIDI messages to be transmitted to the external sound generator (p. 58).



About the Function Buttons



[EDIT] Button

By pressing the [EDIT] button to make the indicator light, you can enter "Edit mode." In Edit mode you can make detailed settings for various functions.

You can exit Edit mode by pressing the [EDIT] button, extinguishing its indicator.

[WRITE] Button

Stores the current settings to "Setup" (p. 51).

Editing a Value

If more than one item is shown in a single screen, the "⏏" icon will appear at the left of the item name or value you're editing. This icon is called the "cursor." You can move the cursor by holding down the [EXIT/SHIFT] button and using the [DEC] [INC] buttons.



Cursor

Use the [DEC] [INC] buttons to edit the value of an item for which the cursor (⏏) is displayed.



[DEC] [INC] Buttons

Pressing the [INC] button increases the value, and the [DEC] button decreases it.

If you want the value to continue changing, simply hold down the [DEC] button or [INC] button. For faster value increases, keep the [INC] button pressed down and press the [DEC] button. For decreasing value faster, keep the [DEC] button pressed down and press [INC] button.

Simultaneously pressing the [DEC] and [INC] buttons sets that parameter to the standard default value or switches it off.

Listening to the Demo (DEMO PLAY)

Here's how to listen to these songs.

The RD-300GX features the internal demo songs that exhibit the special capabilities of the instrument.

No.	Song Name	Composer	Copyright
01.	Macho Blues	John Maul	© 2008 Roland Corporation
02.	Fond Farewell	Adrian Scott	© 2008 Roland Corporation
03.	Superior Grand	Scott Tibbs	© 2004 Roland Corporation

NOTE All rights reserved. Unauthorized use of this material for purposes other than private, personal enjoyment is a violation of applicable laws.

NOTE No data for the music that is played will be output from the MIDI OUT connector.

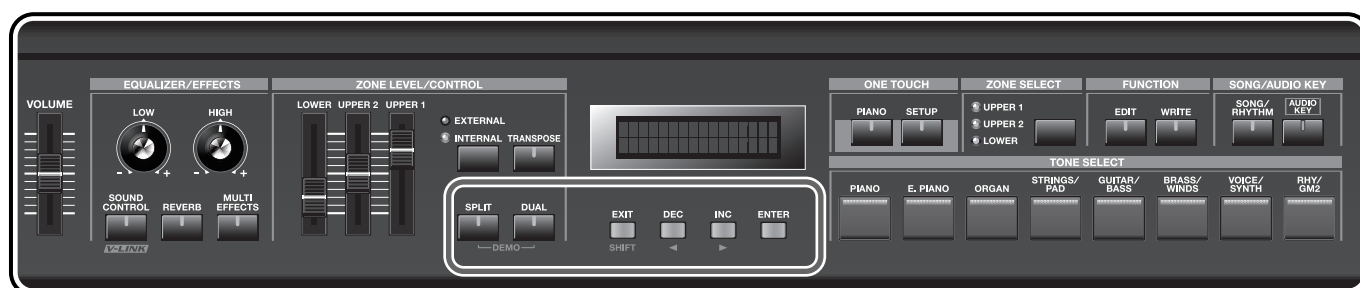

MEMO When you enter Demo mode, the various settings will be in the same state as they are immediately after the RD-300GX is powered up. Store any arrangements of settings that you want to keep in Setup (p. 51).

1. Hold down the [SPLIT] button and press the [DUAL] button.

The Demo screen appears.



2. Use the [DEC] [INC] buttons to select the song you want to hear.

3. Press the [ENTER] button to start the playback of the song.

When the last song finishes playing, playback will return to the first song and continue.

4. Press the [EXIT/SHIFT] button or the [ENTER] button to stop a song during playback.

5. Press the [EXIT/SHIFT] button while the song is stopped to finish with the Demo screen.

MEMO Regardless of whether the song is playing or stopped, pressing the ONE TOUCH [PIANO] button ends the demo and returns the original screen to the display.

Piano Performances (ONE TOUCH [PIANO] Button)

Now, try performing with the piano.

The RD-300GX lets you call up the ideal settings for piano performance at any time simply by pressing a button.



1. Press the **ONE TOUCH [PIANO]** button.

The ONE TOUCH PIANO screen appears.



Pressing the ONE TOUCH [PIANO] button sets the entire keyboard to play with the piano tone.

NOTE Pressing the ONE TOUCH [PIANO] button restores all of the settings except for the Piano Designer (p. 60) settings to their status at the time the power was turned on. If you want to preserve these settings, record them to a Setup (p. 50).

MEMO You can use the [DEC] [INC] buttons in the ONE TOUCH PIANO screen to adjust the amount the grand piano lid is opened.

MEMO You can specify whether song playback will stop if you press the ONE TOUCH [PIANO] button while a song is playing. For details, refer to "Having Song Playback Stop when You Press a ONE TOUCH Button (Song Stop Mode)" (p. 67).

With the RD-300GX, you can also make more detailed settings to make the sound even better match your favorite piano performances. You can store the settings configurations to the ONE TOUCH [PIANO] button.

Please refer to the following as needed.

- Fine Adjustment of Piano Tones (Piano Designer) → p. 60

Performing with a Variety of Tones (TONE SELECT Buttons)

The RD-300GX comes with a many built-in Tones.

Each one of these individual sounds is called a "Tone."

Tones are assigned to the TONE SELECT buttons according to the Tone category selected.

Try selecting and performing with a number of different Tones.

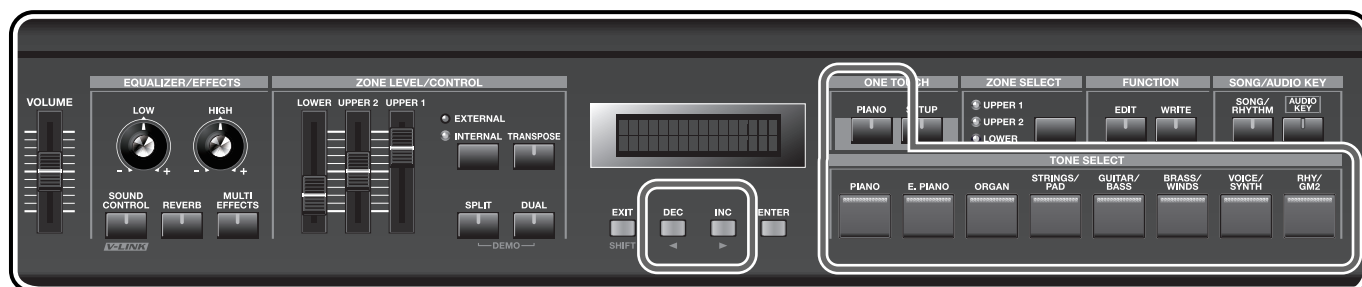

1. Press the ONE TOUCH [PIANO] button.

This selects a single tone to be played over the entire keyboard.

```
ONE TOUCH PIANO
Superior Grd
```



If multiple tones are playing, do not press the ONE TOUCH [PIANO] button, but instead select the Zone containing the Tone to be changed using the ZONE SELECT button. Refer to "Changing the Tone for a Zone (ZONE SELECT Button)" (p. 31).

2. Press any of the TONE SELECT buttons to select the Tone category.

The indicator of the TONE SELECT button for the selected category will light.

```
UPPER1
001: Superior Grd
```

3. Use the [DEC] [INC] buttons to select the Tone.

Play the keyboard, and you will hear the selected Tone.

The next time you choose this TONE SELECT button, the Tone you're selected here is played.



Tones selected with the [RHY/GM2] button are registered in the following order: "Rhythm Sets," "GM2 Rhythm Sets," and "GM2 Tones." Refer to the "Tone List" (p. 91).

Playing Multiple Tones with the Keyboard

The RD-300GX features three Internal Zones (UPPER 1, UPPER 2, and LOWER), and one Tone can be assigned to each of these Zones.

You can perform using combinations of Tones by turning each Zone on or off. You can have multiple Tones layered together at the same time, and even have different Tones played in the left and right parts of the keyboard.

Performing with Layered Tones ([DUAL] Button)

The RD-300GX lets you layer two Tones so that they will sound together.



1. Press the [DUAL] button, getting the indicator to light.

Try fingering the keyboard.



The Tones for UPPER 1 and UPPER 2 are layered and played.



2. Press the [DUAL] button once more, and the indicator light goes out.

The Tones for UPPER 1 played.

NOTE

The [DUAL] button has no effect while the EXTERNAL indicator is lit. In order to turn on the External Zone UPPER 2, you must set the MIDI channel for UPPER 2 (p. 55).

Pressing Two TONE SELECT buttons Simultaneously

You can layer two Tones by pressing two TONE SELECT buttons simultaneously.

For example, if you want to layer a piano sound with strings, together press both the [PIANO] button and the [STRINGS] button.

The [DUAL] button's indicator starts to flash, and when you begin playing the keyboard, the piano and strings sounds are layered together.

In this case, the Tone of the button you press first is assigned to UPPER 1, and the other is assigned to UPPER 2; the indicators of the two TONE SELECT buttons will light.

```
UPPER1
001: Superior Grd
```

Once you have selected two TONE SELECT buttons, pressing either TONE SELECT button then selects that Tone to UPPER 1. The UPPER 2 indicator goes out, and that Tone stops playing. Also, the [DUAL] button's indicator will go out.

* The steps described above can be performed if the ZONE SELECT indicator UPPER 1 or UPPER 2 is lit.

Playing Different Tones in Two Different Sections of the Keyboard ([SPLIT] Button)

Such a division of the keyboard into right- and left-hand sections is called a "Split," and the key where the division takes place is called the "Split Point."

While in Split mode, a sound played in the right side is called an "Upper Tone," and the sound played in the left side is called a "Lower Tone." The split-point key is included in the LOWER section.

The Split Point has been set at the factory to "B3."



You can change the split point. Please refer to "Changing the Keyboard's Split Point" (p. 30).

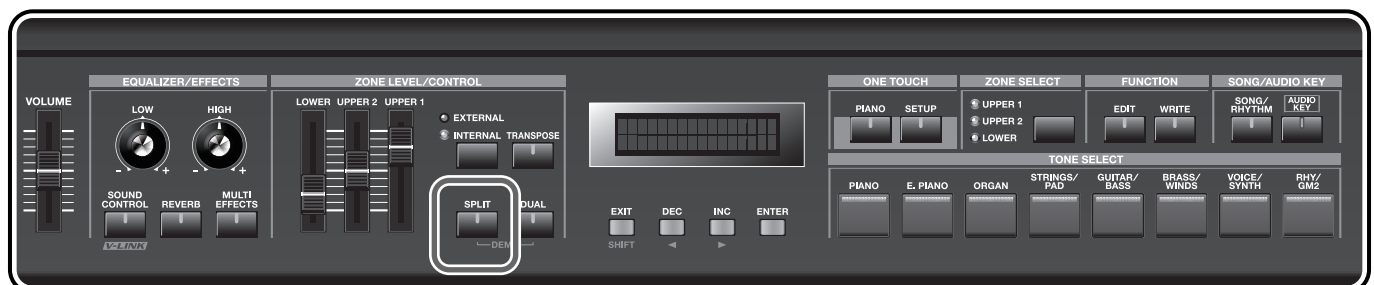

1. Press the [SPLIT] button, getting the indicator to light.

The ZONE SELECT "LOWER" indicator lights.

Try fingering the keyboard.



The UPPER Tone plays in the right-hand section of the keyboard, and the LOWER Tone plays in the left-hand section.

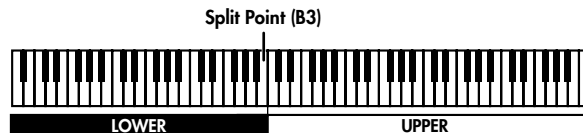

2. To exit Split mode, press the [SPLIT] button once more, and the indicator light goes out.

Changing the Keyboard's Split Point

You can change the point at which the keyboard is divided (the Split Point) in Split mode.

1. Hold down the [SPLIT] button for several seconds.

A screen such as the following appears, and the current value of the setting is displayed.



2. Hold down the [SPLIT] button and press a key.

When you release the [SPLIT] button, the previous display will reappear.

The split-point key is included in the LOWER section.



You can change the split point, adjusting it in semitone increments, by holding down the [SPLIT] button and using the [DEC] [INC] buttons.



You can divide the keyboard into left and right Zones, and play the LOWER Tone in the left Zone while playing the UPPER 1 and UPPER 2 Tones layered in the right Zone.

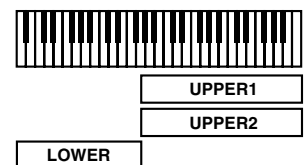

Changing the Tone for a Zone (ZONE SELECT Button)

When changing the Tone assigned to a Zone, use the ZONE SELECT button to specify the Zone with the Tone you want to change.

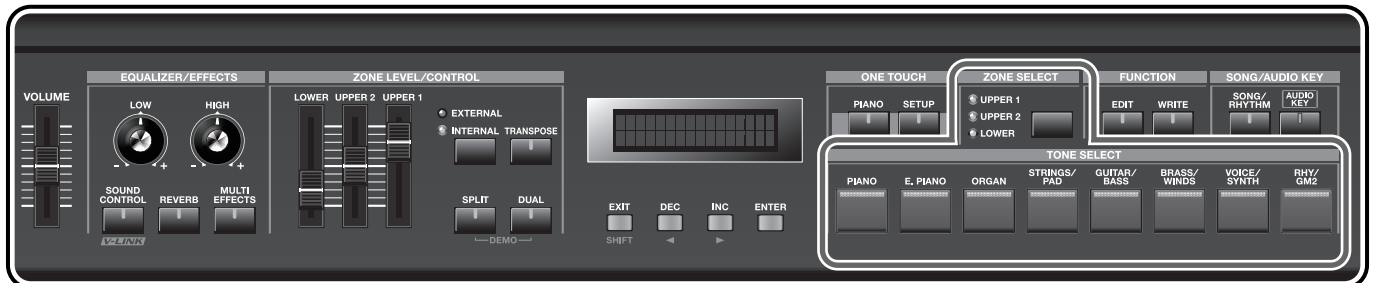

1. Press the ZONE SELECT button so the ZONE SELECT indicator for the Zone you wish to select is lit or blink.

The indicator of the currently selected TONE SELECT button will light in the same color as the indicator of the selected Zone.

2. Use the TONE SELECT buttons to select the Tone category, and then use the [DEC] [INC] buttons to select a Tone.



The [DUAL] button's indicator will blink if the UPPER 2 Zone is not on, and the [SPLIT] button's indicator will blink if the LOWER Zone is not on. If you want to play sounds in each Zone, press the corresponding button so the indicator is lit.

Adjusting the Volume Level for Individual Zones (ZONE LEVEL Sliders)

With the RD-300GX, each of the parts that is performed using the internal sound generator is referred to as an Internal Zone.

For each Zone (UPPER 1, UPPER 2, and LOWER), you can use the ZONE LEVEL sliders to adjust the volume of an individual Zone.

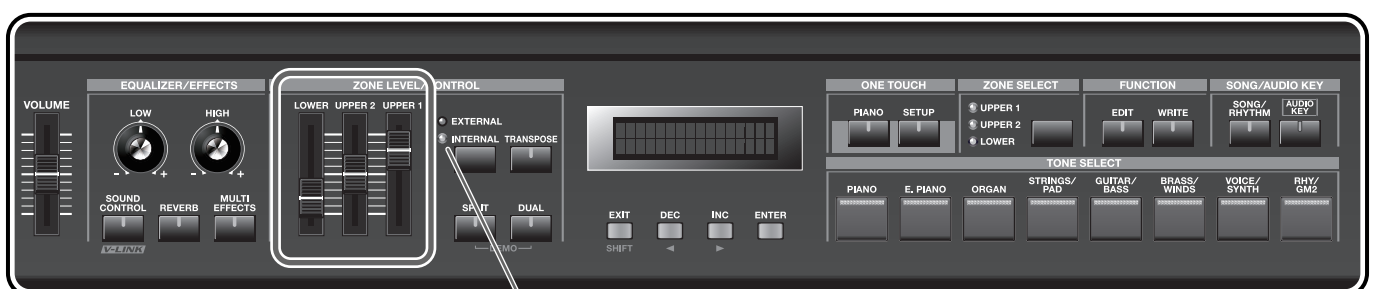

INTERNAL indicator is lit



Use the VOLUME slider when adjusting the overall volume level (p. 20).

Zones to which Tones from external sound modules are assigned are called External Zones. With the RD-300GX, you can control both the External and Internal Zones in the same manner. For more on the control of External Zone, refer to "Adjusting the Volume of Each Zone (External Zone)" (p. 57).

Transposing the Key of the Keyboard ([TRANSPOSE] Button)

You can transpose performances without changing the keys you are playing, as well as change the pitch by an octave. This feature is called "Transpose."

This is a convenient feature to use when you want to match the pitch of the keyboard performance to a vocalist's pitch, or perform using the printed music for trumpets or other transposed instruments.

You can adjust the transpose setting in semitone steps over a range of -48-0-+48 relative to C4.

NOTE Note messages from MIDI IN connector will not be transposed.

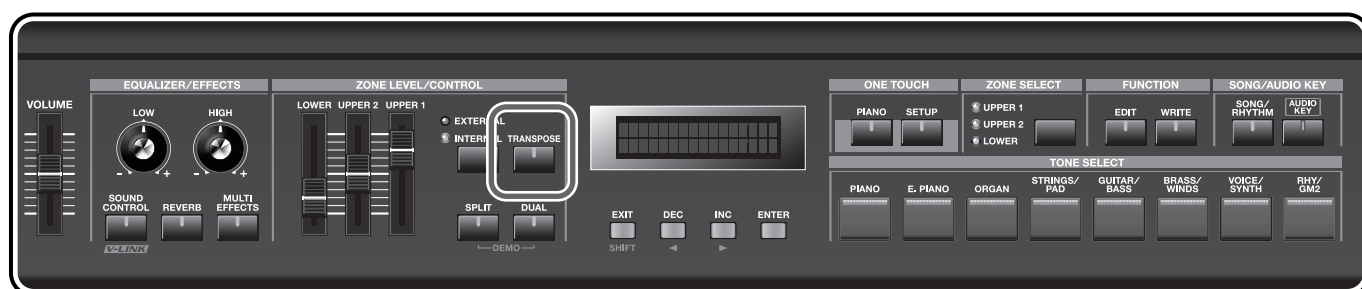

1. Hold down the [TRANSPOSE] button for several seconds.

A screen such as the following appears, and the current value of the setting is displayed.



2. Hold down the [TRANSPOSE] button and press a key.

For example, to have "E" sound when you play "C" on the keyboard, hold down the [TRANSPOSE] button and press the E4 key. The degree of transposition then becomes "+4." When you release the [TRANSPOSE] button, the previous display will reappear.

When the amount of transposition is set, the Transpose function switches on, and the [TRANSPOSE] button lights up.

When the transpose value is set to "0," the button's indicator will remain dark even if you press the [TRANSPOSE] button.

MEMO You can also transpose by holding down the [TRANSPOSE] button and using the [DEC] [INC] buttons.

MEMO Even when the Transpose function is turned on, the Split Point remains unchanged (p. 30).

3. To turn off Transpose, press the [TRANSPOSE] button so that its indicator goes off.

The next time [TRANSPOSE] button is pressed, the sound is transposed by an amount corresponding to the value set here.

MEMO You can set the degree of transposition for each of the Zone individually. For details, refer to "Setting the Transposition for Each Individual Zone (Transpose)" (p. 70).

Adding Reverberation to the Sound ([REVERB] Button)

The RD-300GX can apply a reverb effect to the notes you play on the keyboard. Applying reverb adds pleasing reverberation to what you play, so it sounds almost as if you were playing in a concert hall.



1. Press the [REVERB] button, getting its indicator to light.
Try fingering the keyboard.
The reverb effect is applied to the entire tone.
2. To eliminate the Reverb effect, press the [REVERB] button once more, extinguishing the indicator.

Changing the Reverb Effect Type

You can select from six different reverb effect types.

1. While holding down the [EXIT/SHIFT] button, press the [REVERB] button.



2. Use the [DEC] [INC] buttons to switch the reverb type.

TYPE	Explanation
STAGE	This reverb simulates the reverberation of a stage. It produces more reverberation than HALL.
ROOM	Simulates the reverberation of room interiors. It produces a well-defined and spacious reverberation.
HALL	Simulates the reverberation exhibited by hall. It provides a deeper reverberation than the Room reverbs.
PLATE	Simulates a plate reverb unit (a type of artificial reverb that utilized a metal plate).
GM2 REVERB	Reverb for use with GM2
CATHEDRAL	This reproduces the reverb found in a church cathedral.

3. After determining the type, press the [EXIT/SHIFT] button.

Changing the Depth of Reverb Effect

You can select from 127 levels of depth for the reverb effect.

1. Hold down the [REVERB] button and use the [DEC] [INC] buttons to change the depth of the reverb effect.



When you release the [REVERB] button, the previous display will reappear.

MEMO Reverb depth settings can be made independently for each Zone (p. 69).

Changing the Sound's Pitch in Real Time (Pitch Bend/Modulation Lever)

While playing the keyboard, move the lever to the left to lower the pitch, or to the right to raise the pitch. This is known as Pitch Bend.

You can also apply vibrato by manipulating the lever away from you. This is known as Modulation.

If you move the lever away from you and at the same time move it to the right or left, you can apply both effects simultaneously.

NOTE The effect obtained when you move the lever may differ according to the Tone being used. Additionally, the effect applied by moving the lever is predetermined for each Tone, and cannot be changed.



Pitch Bend



Modulation

Adding Liveliness to the Sound ([SOUND CONTROL] Button)

Switching on the Sound Control function suppresses differences in volume for a more consistent sound.

This is set to OFF when the power is turned on.

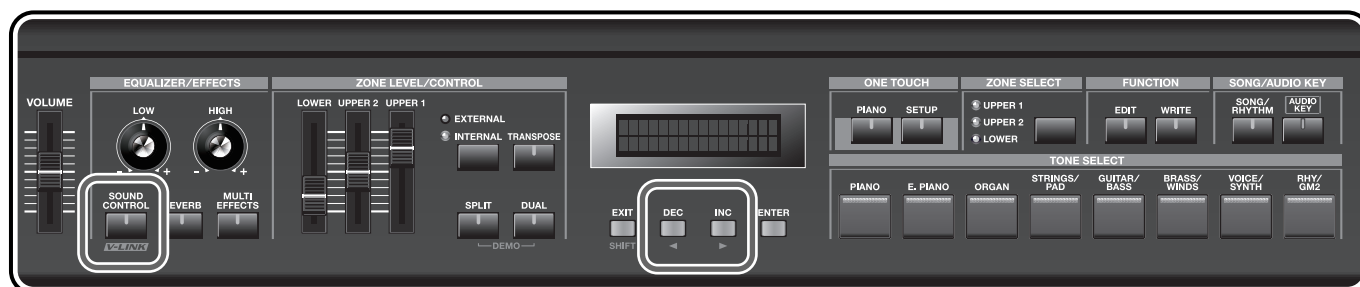

1. Press the [SOUND CONTROL] button, getting its indicator to light.

NOTE Sounds may become distorted with certain Tones. If this occurs, lower the respective ZONE LEVEL sliders.

2. Hold down the [SOUND CONTROL] button and use the [DEC] [INC] buttons to switch the sound control type.

Sound Control
HARD COMP

TYPE	Explanation
HARD COMP	Applies strong compression.
SOFT COMP	Applies mild compression.
LOW BOOST	Boosts the low end.
MID BOOST	Boosts the midrange.
HI BOOST	Boosts the high end.

3. To cancel this function, press the [SOUND CONTROL] button once more, extinguishing the indicator.

Adjusting the Levels of Each Frequency Range (EQUALIZER Knobs)

The RD-300GX is equipped with a two-band equalizer.

You can use the EQUALIZER [LOW] knob, and [HIGH] knob to adjust the level of each frequency range.

NOTE Equalization is applied to the overall sound output from the OUTPUT jacks.

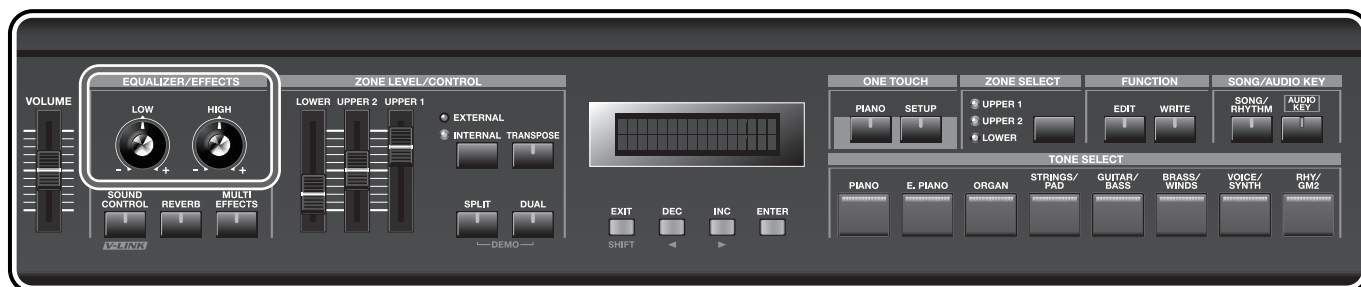

1. Turn the EQUALIZER knobs to adjust the levels in each range.

Turning a knob towards the minus (-) sign cuts the level of that frequency range; turn the knob towards the plus (+) sign to boost the level of that range.

NOTE Depending on the knob settings, you may hear distortion. If so, use the VOLUME slider to lower the volume.

Changing the Frequency of the Low and High Ranges

You can use the EQUALIZER [LOW] and [HIGH] knobs to change the frequency at which the adjustment will occur.

1. While holding down the [EXIT/SHIFT] button, turn the EQUALIZER knobs.

You can adjust the frequency.



2. After determining the value, press the [EXIT/SHIFT] button to return to the previous screen.

Using the Convenient Functions in Performances

Playing Rhythm ([SONG/RHYTHM] Button)

The RD-300GX features internal drum patterns complementing Jazz, Rock, and other various musical genres. These drum patterns are referred to as "Rhythms."

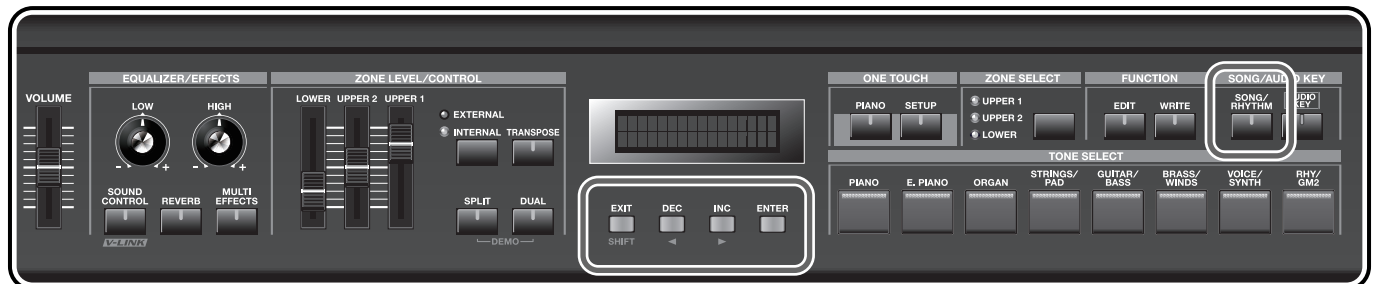

1. Press the [SONG/RHYTHM] button.

```
▶INT ♯=120 M: 1
000:Macho Blues
```

2. While continuing to hold down the [EXIT/SHIFT] button, use the [DEC] [INC] buttons to move the cursor to the upper left of the screen.
3. Use the [DEC] [INC] buttons to select "RHY."

The Rhythm screen appears.

```
▶RHY ♯=120
001:Piano R&B 1
```

4. Press the [ENTER] button.
The Rhythm sounds, and the [SONG/RHYTHM] button indicator lights.
5. Press the [ENTER] button once more; the Rhythm stops playing.
The Rhythm stops, and the [SONG/RHYTHM] button indicator goes out.

Changing Rhythm Pattern

You can select the way a Rhythm is played (the pattern) to match a variety of different musical genres.

1. Access the Rhythm screen.
2. While continuing to hold down the [EXIT/SHIFT] button, use the [DEC] [INC] buttons to move the cursor to the lower left of the screen.

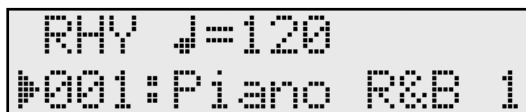

```
RHY ♩=120
#001:Piano R&B 1
```

3. Use the [DEC] [INC] buttons to select the pattern.
4. Press the [ENTER] button.
The Rhythm sounds, and the [SONG/RHYTHM] button indicator lights.
5. Press the [ENTER] button once more; the Rhythm stops playing.
The Rhythm stops, and the [SONG/RHYTHM] button indicator goes out.



For more information about the kind of Rhythm Patterns, please refer to "Rhythm Pattern List" (p. 97).

Changing Rhythm Tempos

1. Access the Rhythm screen.
2. While continuing to hold down the [EXIT/SHIFT] button, use the [DEC] [INC] buttons to move the cursor to the upper right of the screen.



```
RHY ♩=120
001:Piano R&B 1
```

3. Use the [DEC] [INC] buttons to select the tempo.
The Rhythm are played at the selected tempo.



The way Rhythm is played and the tempo display may differ with some Rhythm Patterns.

Changing Rhythm Volume

1. While holding down the [SONG/RHYTHM] button, move any of the ZONE LEVEL sliders.
The volume of the Rhythm changes.

**NOTE**

You won't be able to change the Rhythm volume if Rhythm is not set to play. If the audio file is set to play, this operation will change the audio volume.

How do I access the Rhythm screen again while keeping the rhythm playing?

Suppose that while the rhythm was playing, you switched from the Rhythm screen to a different screen. In this state, pressing the [SONG/RHYTHM] button in order to move back to the Rhythm screen will stop the rhythm.

In such cases, you can press and continue holding the [SONG/RHYTHM] button for about one second to access the Rhythm screen without stopping the rhythm.

Playing Songs ([SONG/RHYTHM] Button)

Here's how to play back SMF music files or audio files (WAV, MP3).
You can play songs that are saved on USB memory (sold separately).

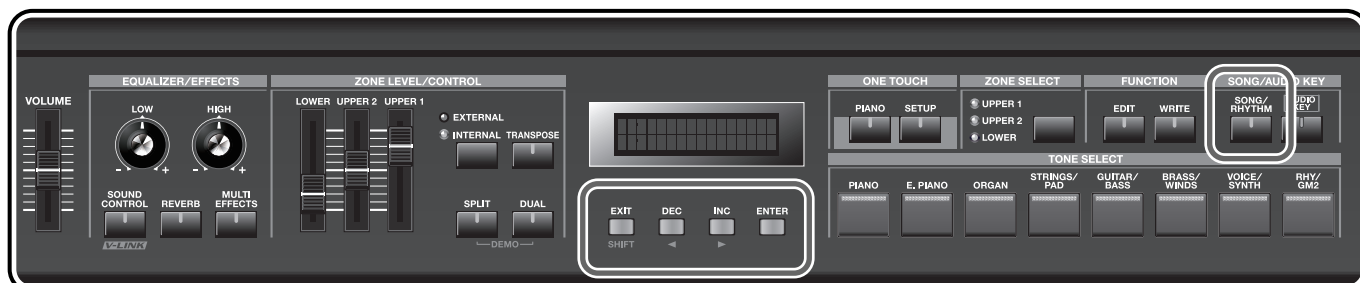

1. Press the [SONG/RHYTHM] button.

The Song screen appears.

If the following screen doesn't appear, refer to "Switching between the Rhythm screen and Song screen" (p. 23).



2. While continuing to hold down the [EXIT/SHIFT] button, use the [DEC] [INC] buttons to move the cursor to the upper left of the screen.

3. Use the [DEC] [INC] buttons to select "INT" or "USB."

Select "INT" to play songs saved in internal memory, or "USB" to play songs saved in USB memory.

NOTE You can't select "USB" unless USB memory is connected to the USB Memory connector.

4. While continuing to hold down the [EXIT/SHIFT] button, use the [DEC] [INC] buttons to move the cursor to the lower left of the screen.

5. Use the [DEC] [INC] buttons to select a song.

6. Press the [ENTER] button.

The song sounds, and the [SONG/RHYTHM] button indicator lights.

7. Press the [ENTER] button once more; the song stops playing.

The song stops, and the [SONG/RHYTHM] button indicator goes out.

Song number "000" is programmed with a Preset song.

Enjoy performing on the keyboard along with this song as it is played back.

No.	Song Name	Composer	Copyright
000.	Macho Blues	John Maul	© 2008 Roland Corporation



You can make the following settings related to song playback.

- Change the way in which songs play (play a single song, play all songs)
- Transpose the song playback
- Minimize sounds located in the center, such as the melody

For details, refer to "Settings Related to Song Playback (Song Function)" (p. 76).

Changing Song Tempos

You can change the tempo for songs.

1. In the Song screen, hold down the [EXIT/SHIFT] button and use the [DEC] [INC] buttons to move the cursor to the tempo indication.

```
INT  ↓=120  M:  1
000:Macho Blues
```

2. Use the [DEC] [INC] buttons to change the tempo.

Here's how to change the playback speed of audio files (WAV, MP3).

1. In the Song screen, hold down the [EXIT/SHIFT] button and use the [DEC] [INC] buttons to move the cursor to the percent indication in the top line of the screen.
2. Use the [DEC] [INC] buttons to change the playback speed.

You can change the playback speed in a range of -25%—+25%.

```
USB  ←-25% 00' 00"
001:Take a Brea
```

Fast-forwarding or Rewinding a Song

1. In the Song screen, hold down the [EXIT/SHIFT] button and use the [DEC] [INC] buttons to move the cursor to the measure indication (or the playback time indication) in the upper right of the screen.

```
INT  ↓=120  M:  1
000:Macho Blues
```

```
USB   0% 00' 00"
001:Take a Brea
```

2. Use the [DEC] [INC] buttons to change the value.

The playback position will change as shown by the indication.

How do I access the Song screen again while keeping the song playing?

Suppose that while the song was playing, you switched from the Song screen to a different screen. In this state, pressing the [SONG/RHYTHM] button in order to move back to the Song screen will also stop the song.

In such cases, you can press and continue holding the [SONG/RHYTHM] button for about one second to access the Song screen without stopping the song.

Performing with Audio Files ([AUDIO KEY] Button)

The RD-300GX lets you play audio files saved on USB memory (sold separately) while you perform. This is called the “Audio Key” function.

The Audio Key function lets you assign an audio file to each key B \flat 0–B1, and play those audio files by pressing the corresponding key. You can assign various phrases to the keys and play them at the appropriate moments during your performance.

You can also specify that an audio file play repeatedly, or reserve the audio file that should be played next.



If you turn on the Audio Key function when USB memory containing audio files is not connected, an audio file built into the RD-300GX will be selected.



Here are some ways in which you can enjoy using the Audio Key function.

- By switching audio files between sections such as Intro, Theme, Break, and Ending as your song progresses, you can freely change the structure of the song while you perform.
- Assign a different audio song to each key, and use the keyboard to switch songs so you can perform to the accompaniment of an audio song.



Performing with Audio Files from USB Memory

Here’s how you can perform while playing audio files saved on USB memory (sold separately).

Before you begin, install the included “Audio Key Utility 2” into your computer, and prepare the audio file set that you want to play back on the RD-300GX.

The included CD-ROM contains a sample audio file set that you can copy to USB memory and use.

1. Connect the USB memory containing the audio file set to the USB MEMORY connector (p. 21).
2. While holding down the [AUDIO KEY] button, and use the [DEC] [INC] buttons to select an audio file set.



When you take your finger off the button, a screen like the following will appear.

```
Press Key
Bb0 to B 1
```

3. Play a key B \flat 0–B1.

The audio file assigned to the respective key will play.

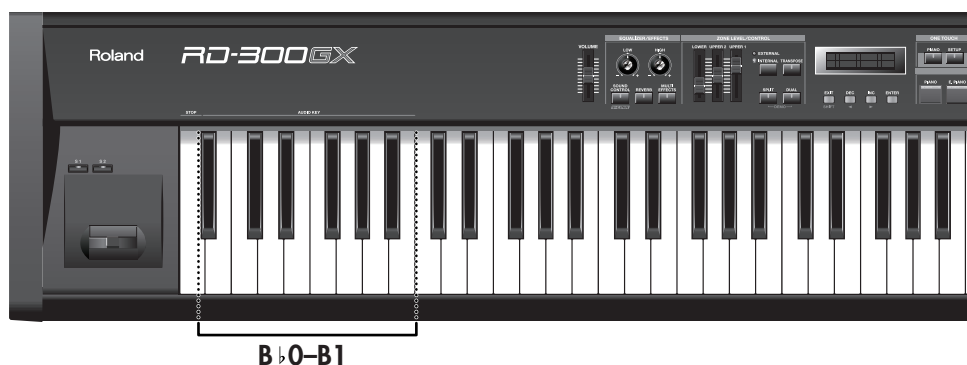

If you play the B0 key, a screen like the following will appear.

```
B00 : LW: Verse 1.
```

The Audio Key function will be activated, allowing you to play audio files by pressing a key.

Indication	Explanation
O	One-shot Now When you press the key, the audio file will play only once. The audio file will play immediately when you press the key.
OW	One-shot Wait When you press the key, the audio file will play only once. With this setting, pressing the key while another audio file is playing will reserve the audio file to be played next. When the currently playing audio file has finished, the reserved audio file will play.
L	Loop Now When you press the key, the audio file will play repeatedly. The audio file will play immediately when you press the key.
LW	Loop Wait When you press the key, the audio file will play repeatedly. With this setting, pressing the key while another audio file is playing will reserve the audio file to be played next. When the currently playing audio file has finished, the reserved audio file will play.



Playing the keys won't produce sound unless a file has been assigned. If a file is currently playing, it will continue sounding.

Keys set to "OW" or "LW" let you reserve the audio file that will be played when the currently playing audio file has finished playing. If you've pressed the B0 key and then press the C1 key to reserve the next-played audio file, the screen will show as follows.

```
B00 : LW: Verse 1.
C01 : LW: Verse 2.
```

The currently reserved audio file is shown in the lower line of the screen.

4. To stop the file that's playing, press the A0 key.

Audio file playback will stop.



For details on installing the included "Audio Key Utility 2" into your computer, refer to "Audio Key Utility 2 Quick Guide" (separate document).



If no USB memory (sold separately) containing audio files is connected to the RD-300GX, you'll be able to play audio files that are built into the RD-300GX (see the section that follows).

If the connected USB memory does not contain an audio file set created by the "Audio Key Utility 2," you'll be able to assign audio files from USB memory to each key and play them.



You can also change the settings of the audio files assigned to the keys, and change the settings that specify how the audio files will be repeated (p. 46).

The changes you make will be lost if you select another audio file set. If you don't want to delete it, carry out the Write procedure.

Caution when Playing Back Audio Files

Playing back an MP3 file or changing the playback tempo of an audio file places a significant processing burden on the RD-300GX, and in some cases may cause it to be unable to completely process all of the performance data from the keyboard.

If this occurs, you may be able to solve the problem by taking the following actions.

- Use WAV/AIFF format data rather than MP3 format data
- Return the song tempo to its original setting (to 0%)

An MP3 file has little time of the blank at the head and the end of the file. Therefore, the sound might cut off when an MP3 file played repeatedly with Audio Key function.

If this occurs, you may be able to solve the problem by taking the following actions.

- Use WAV/AIFF format data rather than MP3 format data

Performing with Audio Files that are Built Into the RD-300GX

If USB memory (sold separately) containing audio files is not connected, you'll be able to play audio files that are built into the RD-300GX.



Even if you're using the audio file set that's built into the RD-300GX, you can change the settings of the audio files assigned to the keys, and change the settings that specify how the audio files will be repeated (p. 46).

Even if you don't turn off the power, the changes you make will be lost if you connect USB memory and select another audio file set.



If you're using an audio file that's built into the RD-300GX, you can't save your changes in USB memory.

Adjusting the Volume of Audio Key

You can adjust the volume when using the Audio Key function.

You can adjust the volume of the Audio Key to change the volume balance between your keyboard performance and the audio file playback.

1. While holding down the [AUDIO KEY] button, move the ZONE LEVEL slider to adjust the volume of the Audio Key.

The volume can be adjusted to any value from 0 to 127.



You can also adjust the Audio Key volume by using the "Audio Level" setting in the System edit screen (p. 67).



When you change the Audio Key volume, this will also affect the volume at which audio files will play back in the Song screen.

How do I access the Audio Key screen again while keeping the audio file playing?

Suppose that while the audio file was playing, you switched from the Audio Key screen to a different screen. In this state, pressing the [AUDIO KEY] button in order to move back to the Audio Key screen will also stop the playback.

In such cases, you can press and continue holding the [AUDIO KEY] button for about one second to access the Audio Key screen without stopping the playback.

Changing Audio File Settings

Here's how you can edit the audio file settings, such as changing the audio file played by each key, or specifying whether the file will be played repeatedly.

1. Connect the USB memory containing the audio file set to the USB MEMORY connector (p. 21).
2. While holding down the [AUDIO KEY] button, and use the [DEC] [INC] buttons to select an audio file set.



AUDIO KEY
▶Seven Wonders

When you take your finger off the button, a screen like the following will appear.

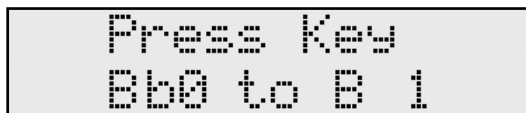

Press Key
Bb0 to B 1

The Audio Key function will be activated, allowing you to play audio files by pressing a key.

3. Press the [ENTER] button.

The following screen appears.

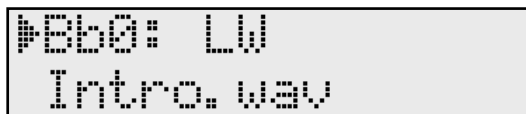

▶Bb0: LW
Intro.wav

4. Hold down the [EXIT/SHIFT] button and use the [DEC] [INC] buttons to move the cursor, and then use the [DEC] [INC] buttons to change the setting for each key.

You can also press the key whose settings you want to change.

Move the cursor to the upper right of the screen, and change the way in which the audio file will play ("O," "OW," "L," "LW"). Refer to the table on p. 43.

Move the cursor to the lower line of the screen, and change the audio file that is assigned to the key. If you press the [DEC] [INC] buttons simultaneously, the audio file assigned to that key will be cleared.

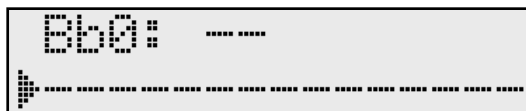

Bb0: ---
▶-----

5. Press the [ENTER] button.

A confirmation message will appear.



Are you sure?
[EXIT]/[ENTER]

If you don't want to store the settings, press the [EXIT/SHIFT] button. The operation will be cancelled.

6. Press the [ENTER] button to overwrite the settings of the audio file set.

NOTE

If you're using an audio file that's built into the RD-300GX, you can't save your changes in USB memory.

Applying Effects to the Sound ([MULTI EFFECTS] Button)

In addition to reverb (p. 33), the RD-300GX also allows you to apply “multi effects” to sounds. Multi effects provides a collection of 78 different effects, such as distortion and rotary, from which you can choose.

The factory settings have a suitable effect assigned to each of the Tones.



1. Press the [MULTI EFFECTS] button, getting its indicator to light.
Try fingering the keyboard.
The effect is applied to the currently selected Tone.
2. To remove the effect, press the [MULTI EFFECTS] button once more, extinguishing the indicator.

MEMO Effects may not be applied with some of sounds.

MEMO If the effect applied to the Tone of each Zone differs when you're using Dual mode or Split mode, you can specify the Zone to which the effect will be applied. For details, refer to “Setting the Zone to which Multi Effects are Added (MFX Zone)” (p. 68).

Changing the Depth of Effect

You can change the levels of depth for the effect.

The content and range vary according to the MFX type. For more detailed information, refer to “Effect List” (p. 87).

1. While holding down the [MULTI EFFECTS] button, use the [DEC] [INC] buttons to adjust the effect depth.



The screen will show the effect that is applied to the currently selected Tone and the parameters that can be edited.

The next time you choose the same Tone, the effect with the depth you've selected here is applied.

MEMO You can change the effect type. Refer to “Changing the Multi-effects Type” (p. 48).

Choosing the Zone to which the multi-effect will apply

On the RD-300GX, only one type of multi-effect can be used at a time. For this reason, there's a "MFX Zone" setting that lets you choose the Zone to which the multi-effect is to be applied. Be aware that if you're playing more than one Zone simultaneously, there will be a Zone to which the multi-effect is not applied.

Changing the Multi-effects Type

1. While holding down the [EXIT/SHIFT] button, press the [MULTI EFFECTS] button.

The effect name and number appear in the display.



MFX Type
78: SYM. RESONANCE

2. Press the [DEC] [INC] buttons to select the effect type.
3. After determining the type, press the [EXIT/SHIFT] button to return to the previous screen.



For more on the RD-300GX's internal effect types, refer to the "Effect List" (p. 87).

Changing the Undulation of the Organ Tone (Rotary Effect)

The Rotary effect is applied to some Organ Tones you can select with the [ORGAN] button. When one of these Tones is selected, you can use the [MULTI EFFECTS] button to change the speed of the rotary effect.

What the rotary effect does is to add a "spinning" effect similar to the sound of an organ using a rotating speaker.

1. Press the [ORGAN] button and select the organ Tone.

When a Tone that has the Rotary effect added is selected, the [MULTI EFFECTS] button's indicator flashes.

2. Each time pressing the [MULTI EFFECTS] button, switch the speed of the rotary effect between fast and slow rotation.

When the [MULTI EFFECTS] button's indicator flashes, a more fast rotary effect is applied.

When the [MULTI EFFECTS] button's indicator blinks, a slower rotary effect is applied.



To prevent the Rotary effect from being applied, select an effect type other than the Rotary effect and then remove the effect.



You can apply the rotary effect to Tones other than the organ Tones as well.

Disabling the Buttons (Panel Lock)

Once Panel Lock is engaged, all buttons (except for the VOLUME slider, [DISPLAY CONTRAST] knob, Pitch Bend/Modulation lever, Pedals, ONE TOUCH [PIANO] button, and [EXIT/SHIFT] button) will not function. This prevents settings from being changed inadvertently on stage or in other such situations.

1. While holding down the [EDIT] button, and press the [ENTER] button.

Continue holding down the [EDIT] button and [ENTER] button until the following display appears.



```
Panel Locked
Press [EXIT]
```

2. Press the ONE TOUCH [PIANO] button, or [EXIT/SHIFT] button to cancel Panel Lock.

Selecting Stored Settings ([SETUP] Button)

The RD-300GX's Internal Zone (p. 22) and External Zone (p. 22) Tone settings, effect settings, and other such settings are collectively referred to as a "Setup."

Once you've stored your preferred settings, and settings for the songs to be performed as a Setup, you can then switch whole groups of settings during a performance just by switching Setups.

You can store up to 32 different Setups.

The RD-300GX is shipped from the factory with recommended Setups already prepared.

Now try actually calling up a Setup.

NOTE The current settings are erased when a Setup is called up. Be sure to save any Setup you would like to keep first before calling up another Setup (p. 51).

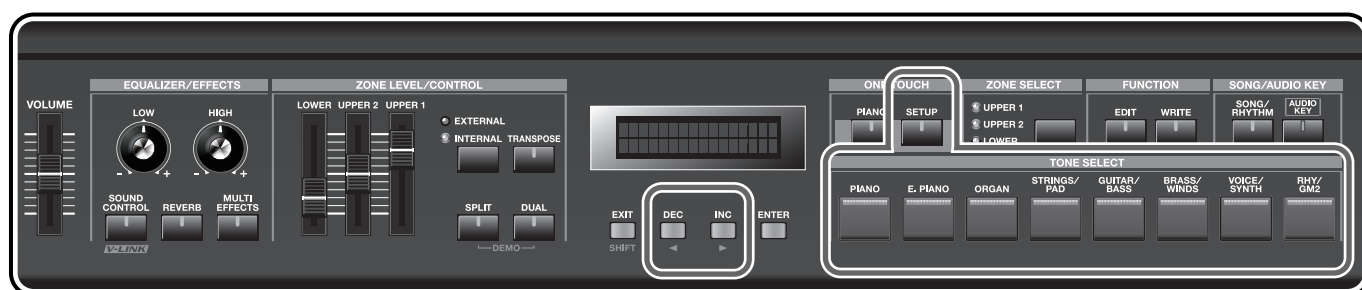

1. Press the [SETUP] button, getting the indicator to light.

The following screen appears in the display.



2. Use the [DEC] [INC] buttons or press one of the TONE SELECT buttons to select the Setup that you want to call up.

By pressing the TONE SELECT buttons you can select four Setups from each button (p. 98).



Try playing the keyboard.

The settings are switched to those of the Setup that has been called up.

MEMO Once you've selected a Setup, pressing that [SETUP] button will take you to the screen shown in step 2.

MEMO Setups indicated by a "R." before the name let you enjoy performing with a session-like feel while playing a Rhythm. Be sure to check it out.

Storing Settings to Setups ([WRITE] Button)

If you want to use the changed content as a new Setup, use the following procedure to save the settings to a Setup.

You can also change the name of a Setup.

You can store 32 Setups on the RD-300GX.

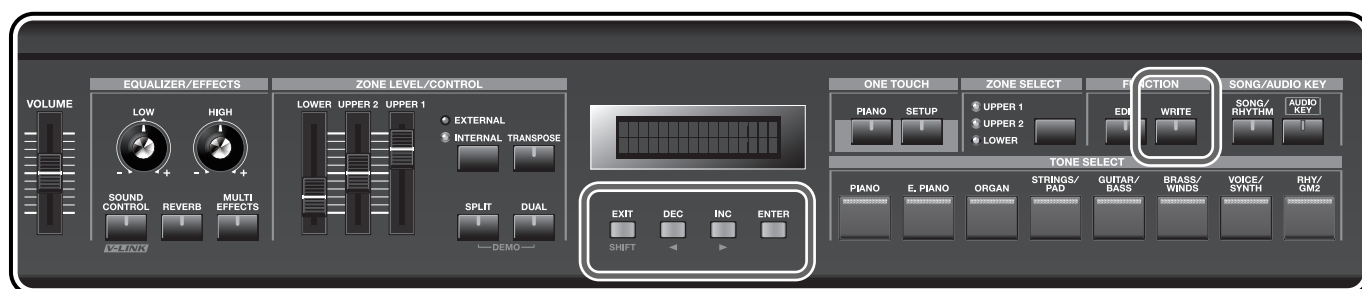

1. Press the [WRITE] button, getting the indicator to light.

The following screen appears.

```

▶ [Piano&Choir ]
  01:Piano&Choir
  
```

2. While holding down the [EXIT/SHIFT] button, use the [DEC] [INC] buttons to move the cursor (.....) to the positions where the characters are to be input.
3. Use the [DEC] [INC] buttons to enter the characters.
The following characters are available.
space, ! " # \$ % & ' () * + , - . / 0-9 : ; < = > ? @ A-Z [\] ^ _ ` a-z { | } ~
4. Repeat steps 2-3 to input the name.
5. Press the [ENTER] button to move the cursor to the destination Setup number.

```

[Piano&Choir ]
▶01:Piano&Choir
  
```

6. Select the save-destination Setup number, by using the [DEC] [INC] buttons.

7. When you have finished determining the save destination and the name for the new Setup, press the [ENTER] button.

The [ENTER] and [EXIT/SHIFT] buttons' indicators are flashing, and the confirmation message appears.



```
SETUP Write
Are you sure?
```

If you do not want to save the Setup, press the [EXIT/SHIFT] button or [WRITE] button. The operation is cancelled.

8. When the [ENTER] button is pressed, saving of the Setup begins.

When you have finished saving the Setup, the [WRITE] button's indicator goes out and you are returned to the previous screen.

NOTE Never switch off the power while "Executing..." appears in the display.

Settings Not Saved in a Setup

The following settings cannot be saved to a Setup.

- TRANSPOSE Settings (p. 32)
- SOUND CONTROL Settings (p. 35)
- EQUALIZER knob Settings (p. 36)
- System Settings (p. 64)
- V-LINK Settings (p. 82)

Using the RD-300GX As a Master Keyboard

By connecting an external MIDI device to the MIDI OUT connector on the RD-300GX's rear panel, you can then control the external MIDI device with the RD-300GX.

Normally, the RD-300GX will transmit note messages from the MIDI OUT connector, but if you press the [EXTERNAL/INTERNAL] button so the "EXTERNAL" indicator is lit, you'll be able to control various settings on your external MIDI device in addition to transmitting note messages.

You can control internal and external sound generators independently.

If you press the [EXTERNAL/INTERNAL] button so the "EXTERNAL" indicator is lit, the RD-300GX will be in a state where it can control an external MIDI sound module (External Zone). You use the [EXTERNAL/INTERNAL] button to switch between control of the Internal Zone and control of the External Zone. You can also make detailed settings for MIDI messages transmitted to external sound modules.

What's MIDI?

MIDI (Musical Instrument Digital Interface) is a standard specification that allows musical data to be exchanged between electronic musical instruments and computers. By using a MIDI cable to connect devices that have MIDI connectors, you can create an ensemble in which a single MIDI keyboard can play multiple instruments, or change settings automatically as the song progresses.

About MIDI Connectors

The RD-300GX has the following three types of MIDI connector. Their functions differ as described below.

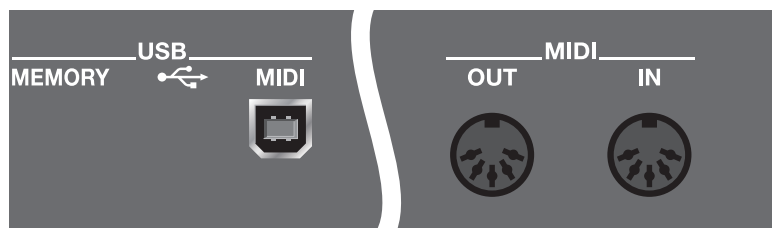

MIDI IN Connector

Performance messages from an external MIDI device are received here. These incoming messages may instruct the RD-300GX to play sounds or switch Tones.

MIDI OUT Connector

MIDI messages are transmitted from this connector to an external MIDI device. The RD-300GX's MIDI OUT connector is used for sending the performance data of the controller section as well as data used for saving various settings (Bulk Dump→p. 77).

USB MIDI Connector

Use a commercially available USB cable to connect this to your computer's USB connector. You can use MIDI-compatible software on your computer to transmit SMF files for playback by the RD-300GX, or set up a sophisticated music production system in which MIDI data is transferred between your sequencer software and the RD-300GX.

Connecting to External MIDI Sound Generators

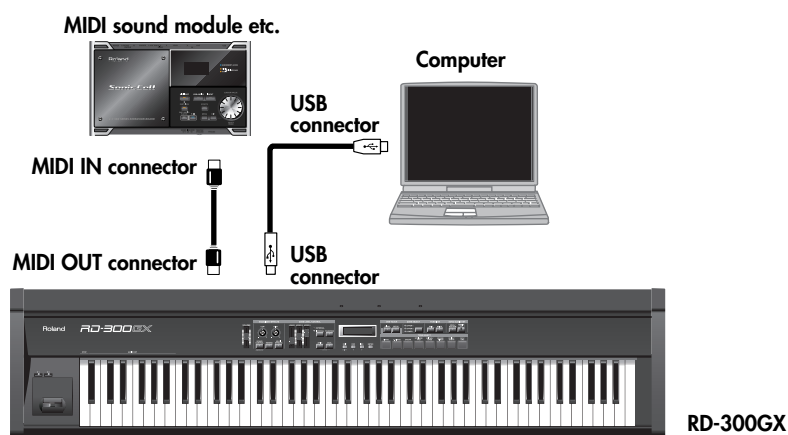

NOTE Use a USB Cable no longer than 5 meters.

Setting the MIDI Transmit Channel (MIDI OUT Channel)

When you have finished connecting the external MIDI device, match the keyboard's Transmit channel and the Receive channel for each of the external MIDI sound generator's Parts. Sounds is produced when the MIDI channels for the sending device (the RD-300GX) and the receiving device (the external MIDI sound generator) are set to the same MIDI channel.

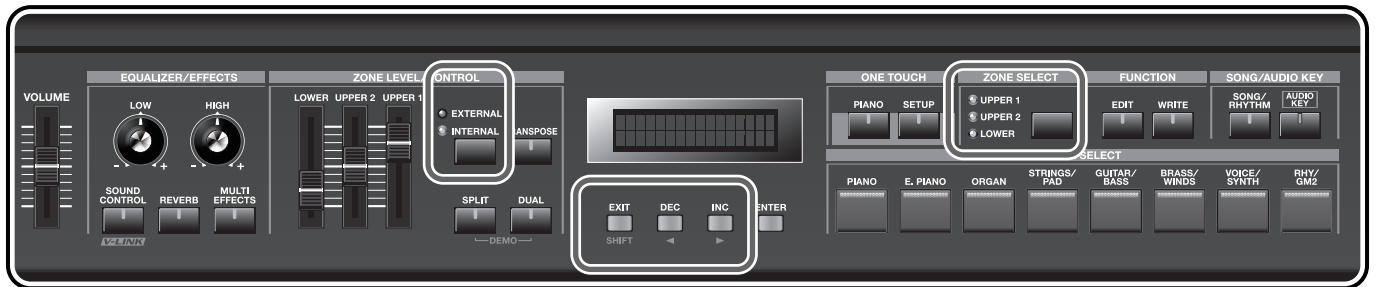

1. Press the [EXTERNAL/INTERNAL] button so the "EXTERNAL" indicator is lit.

The External screen appears.

If the following screen doesn't appear, hold down the [EXIT/SHIFT] button and press the [DEC] button several times.



2. Press the ZONE SELECT button so the indicator of the button for the Zone you wish to select is lit.

Part	Parameter	Settings	Description
UPPER 1	Ch (MIDI OUT Channel)	1-16, OFF	RD-300GX performance data is sent over a selected channel.
UPPER 2			
LOWER			

3. Use the [DEC] [INC] buttons to set the transmit channel for each Zone.

If you turn this "OFF," MIDI data will not be transmitted for that Zone.



For instructions on setting each of the external MIDI sound generator's Part's Receive channel, refer to the owner's manual for each device.



When "Rec Mode" is set to ON in the Utility in Edit mode, the External screen as shown above is not displayed. Set "Rec Mode" to OFF when setting the MIDI Transmit channel (p. 78).

Selecting Sounds on an External MIDI Device (MSB/LSB/PC)

To switch the tones of an external MIDI device, the program number and the MSB/LSB of the Bank Select message are entered as numerical values on the RD-300GX.

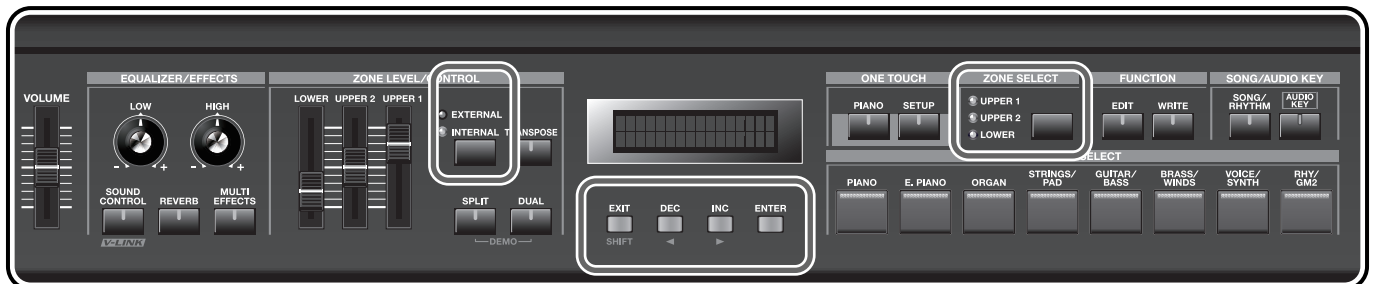

1. Press the [EXTERNAL/INTERNAL] button so the “EXTERNAL” indicator is lit.

The External screen appears.

If the following screen doesn't appear, hold down the [EXIT/SHIFT] button and press the [DEC] button several times.



2. Press the ZONE SELECT button so the indicator of the button for the Zone you wish to select is lit.

3. While continuing to hold down the [EXIT/SHIFT] button, use the [DEC] [INC] buttons to move the cursor, and use the [DEC] [INC] buttons to set the MSB, LSB, and PC for each Zone.

Pressing the [DEC] [INC] buttons simultaneously switches the settings value to “- - - (OFF).” When this setting is “- - - (OFF),” bank select messages will not be transmitted.

Parameter	Settings
MSB (Bank Select MSB: CC 00)	000–127, - - - (OFF)
LSB (Bank Select LSB: CC 32)	000–127, - - - (OFF)
PC (Program Change)	001–128, - - - (OFF)

NOTE

If the external MIDI sound generator receives a Program number or a Bank number for which no Tone has been assigned, an alternate Tone may be selected, or in some cases, there may be no sound played. If you do not want to transmit the Program number or Bank Select, use the procedure described above to set the PC/MSB/LSB to “- - - (OFF).”

If this is set to “- - -,” the sound selection data will not be transmitted when you switch Setups.

Adjusting the Volume of Each Zone (External Zone)

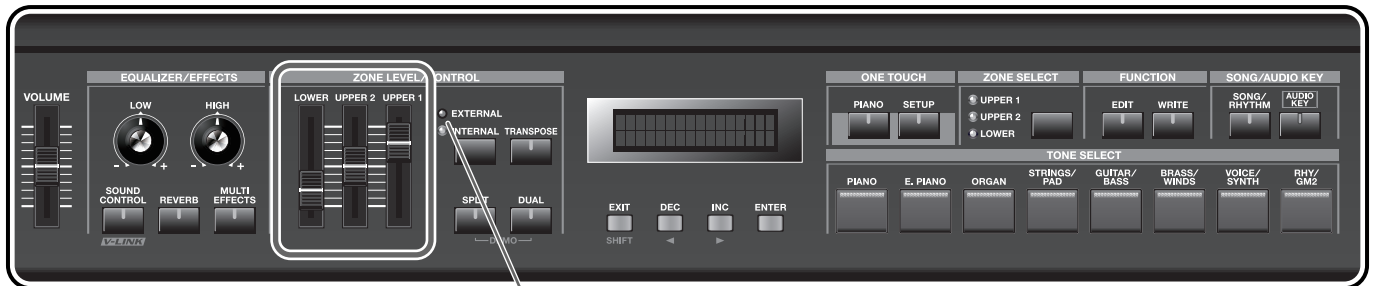

EXTERNAL indicator is lit

When the EXTERNAL indicator is lit, you can use the ZONE LEVEL sliders to control the External Zone in the same way as with the Internal Zone (p. 31).

Detailed Settings for Transmitted Parts ([EXTERNAL/INTERNAL] Button)

If you press the [EXTERNAL/INTERNAL] button so the "EXTERNAL" indicator is lit, you'll be able to set the following items.

Parameter	
Ch	MIDI OUT Channel
MSB	Bank Select MSB
LSB	Bank Select LSB
PC	Program Number
Vol	Volume
Pan	Pan
Rev	Reverb Depth
Cho	Chorus Depth
Trs	Key Transpose
KRL	Key Range Lower
KRU	Key Range Upper

How to Make Settings

1. Press the [EXTERNAL/INTERNAL] button so the "EXTERNAL" indicator is lit.

The RD-300GX is set to control the external MIDI devices.

NOTE

The External screen shown will not appear if "Rec Mode" is "ON" in Utility edit. Turn the Rec Mode setting "OFF" (p. 78).

2. While continuing to hold down the [EXIT/SHIFT] button, use the [DEC] [INC] buttons to select the parameter to be set.

3. Use the ZONE SELECT button to select the Zone for which you want to make settings.

The indicator of the selected Zone will light.

4. Use the [DEC] [INC] buttons to set the value.

Pressing the [DEC] [INC] buttons simultaneously sets the value to "--," "OFF," or "0."

Adjusting the Volume and Pan (Vol/Pan)

Sets the volume and the panning (localizes sound image) for each of the Tones.

The Volume setting is mainly used when multiple tones are playing to obtain the desired balance in volume between each Zone.

The Pan setting positions the sound image of each Zone when the output is in stereo. With an increase in the value for L, more of the sound will be heard as coming from the left side. Similarly, more of the sound will originate at the right if the value of R is increased. When set to 0, the sound is heard as coming from the center.

Parameter	TX CC#	Value
Vol (Volume)	CC07	--- (OFF), 0-127
Pan (Pan)	CC10	L64-0-63R, --- (OFF)

Setting the Amount of Reverb and Chorus (Rev/Cho)

This sets the depth of the reverb and chorus effects.

Parameter	TX CC#	Value
Rev (Reverb)	CC91	--- (OFF), 0-127
Cho (Chorus)	CC93	

Setting the Transposition for Each Individual Zone (Trs)

You can perform with each Zone transposed to a different pitch.

When multiple Zones are set to on, you can create a richer sound by setting the two Tones to different octaves. Also, if the Keyboard Mode is set to Split and you are playing a bass Tone in the lower Part, you can use the Transpose function to play the bass at a lower pitch.

Parameter	Value
Trs (Transpose)	-48 - 0 +48

Setting the Key Range (KRL/KRU)

Set the keyboard range in which each Zone will sound.

This can be used to make notes in different areas of the keyboard play different Tones.

Specify the lower limit (KRL) and upper limit (KRU) of the key range being set.

You can also set this by pressing a specific key and then pressing the [ENTER] button.

Parameter	Value
KRL (Key Range Lower)	A0-C8
KRU (Key Range Upper)	

NOTE

This is effective only when the [SPLIT] button is on (p. 29) in the key range settings.

MEMO

"FUL" is displayed when the [SPLIT] button is set to OFF. In this case, the [SPLIT] button is automatically switched on when the value is changed to something other than "FUL" with the [DEC] [INC] buttons.

NOTE

You cannot set the key range's lower limit higher than the upper limit, nor can you set the upper limit below the lower limit.

MEMO

If you don't want MIDI note data to be transmitted, set the Zone's MIDI OUT Ch to "OFF." (p. 55)

Making Detailed Settings for the ONE TOUCH Tones

Making Detailed Settings for the Piano Tones (Piano Designer)

You can make detailed settings to adjust the piano sound that's used when you press the ONE TOUCH [PIANO] button (p. 26).

This function is called "Piano Designer."

Furthermore, you can save the changed settings.

When the ONE TOUCH [PIANO] button is pressed, all settings other than the Piano Designer settings are switched to their status at the time the RD-300GX's power was turned on.

NOTE

Store any arrangements of settings that you want to keep in Setup (p. 51).

Making the Settings

1. Press the [ENTER] button in the ONE TOUCH PIANO screen to select the type you want to set.
2. Use the [DEC] [INC] buttons to select the parameter to be set, then press the [ENTER] button.



```
#Tone
01: Superior Grd
```

3. Use the [DEC] [INC] buttons to set the value.
4. If you want to save the setting, press the [WRITE] button.
The confirmation message appears.
Press the [ENTER] button to save the settings.
If you want to cancel, press the [EXIT/SHIFT] button.
5. When you finish making settings, press the [EXIT/SHIFT] button.

You are returned to the ONE TOUCH PIANO screen.

NOTE

Depending on the piano tone selected, this setting may not be available.

Selecting the Piano Sound (Tone)

This chooses the piano Tone to be selected when the ONE TOUCH [PIANO] button is pressed.

You can choose from the Tones of the TONE SELECT [PIANO] button.

Changing the Amount of Reverb Effect (Reverb Depth)

This does the same thing as the setting described in "Changing the Depth of Reverb Effect" (p. 34), but this setting can be easily accessed by pressing the ONE TOUCH [PIANO] button.

Parameter	Value	Description
Reverb Amount	0-127	The reverb effect becomes stronger as the value is increased.

Opening/Closing the Piano Lid (Lid)

Reproduces the way the brightness of a grand piano's sound is affected by how much the piano's lid is opened.

Parameter	Value	Description
Lid	1-7	The lid is opened more as the value is increased, creating a brighter sound.

Adjusting the Damper Noise (Damper Noise)

This adjusts the damper noise (the sound that occurs when the strings of an acoustic piano are released by pressing the damper pedal).

Parameter	Value	Description
Damper Noise	0-127	Increasing this value will increase the sound that is heard when the strings are released.

Adjusting the Resonance of the Aliquot Strings (Duplex Scale)

This adjusts the sound of the sympathetically vibrating aliquot strings on an acoustic piano.

Parameter	Value	Description
Duplex Scale	0–127	Higher values will increase the volume of the sympathetic vibration.

What are Duplex Scale?

The Duplex Scale is a system of sympathetically vibrating strings sometimes included in grand pianos.

These sympathetically vibrating strings are not struck directly with hammers, but sound by vibrating in sympathy with the vibrations of other strings. By resonating with the overtones, these strings add richness and brilliance to the sound. These sympathetic strings are added only to the high register above approximately C4. Since they do not have a damper (a mechanism that stops them from sounding), they will continue sounding even after you play a note and then release it to stop the sound of the string that was actually struck.

Adjusting the Resonant Sounds when the Keys are Pressed (String Resonance)

When the keys are pressed on an acoustic piano, the strings for keys that are already pressed also vibrate sympathetically. The function used to reproduce is called “String Resonance.”

Parameter	Value	Description
String Resonance	OFF, 1–127	Increasing the value will increase the amount of effect.

Adjusting the String Resonance Produced when a Key is Released (Key Off Reso.)

This adjusts resonances such as the key-off sound of an acoustic piano (subtle sounds that are heard when you release a key).

Parameter	Value	Description
Key Off Reso. (Key Off Resonance)	OFF, 1–127	Higher values will increase the volume of the resonances.

Adjusting the Sound of the Hammer Strike (Hammer Noise)

This adjusts the sound of the hammer striking the string of an acoustic piano.

Parameter	Value	Description
Hammer Noise	-2–0+2	Higher values will increase the sound of the hammer striking the string.

Precise Modification of Chord Sonorities (Stretch Tune)

Changes the pitch using the “stretch tune” method typically used on acoustic pianos. This makes high-range sounds slightly higher in pitch, and low-range sounds slightly lower in pitch.

Parameter	Value	Description
Stretch Tune	OFF	No stretch tune.
	ON	This is the standard tuning curve.

Changing the Key Touch (Key Touch/Ofst)

Use "Key Touch" to adjust the touch sensitivity of the keyboard.

You can use the "Key Touch Offset" setting to adjust the sensitivity in greater detail.

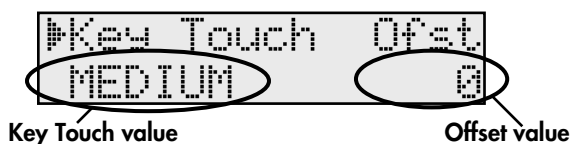

Parameter	Value	Description
Key Touch	SUPER LIGHT	An even lighter setting than LIGHT.
	LIGHT	This sets the keyboard to a light touch. You can achieve fortissimo (ff) play with a less forceful touch than usual, so the keyboard feels lighter. This setting makes it easy to play, even for children.
	MEDIUM	This sets the keyboard to the standard touch. You can play with the most natural touch. This is the closest to the touch of an acoustic piano.
	HEAVY	This sets the keyboard to a heavy touch. You have to finger the keyboard more forcefully than usual in order to play fortissimo (ff), so the keyboard touch feels heavier. Dynamic fingering adds even more feeling to what you play.
	SUPER HEAVY	An even heavier setting than HEAVY.
Ofst (Offset)	-10-0-+9	The touch sensitivity becomes heavier as the value increases.

NOTE

When you change the Key Touch setting, the Key Touch Offset value will be set to "0."

NOTE

When "ofst" setting value continues into the positive or negative direction, the Key Touch's five-step value is switched automatically in accordance with that value.

Setting a Constant Volume Level in Response to the Playing Force (Velocity)

This sets the sound to play at a fixed volume, regardless of the strength used to play the keyboard (the velocity).

Parameter	Value	Description
Velocity	REAL	Volume levels and the way sounds are played change in response to the velocity.
	1-127	Values for the volume and the way sounds are played remain constant.

Changing the Timing of Sounds in Response to the Velocity (Velo Delay Sens)

This sets the interval from the time the key is played to when the sound is produced.

As the value is decreased, the timing of the sound is delayed more when more force is used to play the keys.

As the value is increased, the timing of the sound is delayed more when less force is used to play the keys.

Parameter	Value
Velo Delay Sens (Velocity Delay Sense)	-63-0-+63

Changing How Volume Responds to the Velocity (Key Touch Mode)

If you choose "MODE 2," the volume will change more smoothly in response to your keyboard playing dynamics (velocity).

Parameter	Value
Key Touch Mode	MODE1, MODE2

Detailed Settings for Each Function ([EDIT] Button)

The process of changing Tone parameters to create the tones you like, and changing the settings for various functions is known as “editing.” When the [EDIT] button is pressed and the indicator is lit, the RD-300GX switches to “Edit mode.”

You can save edited settings to Setups.

Edited settings are discarded when the RD-300GX’s power is turned off, so be sure that any settings you want to keep are saved to a Setup (p. 51).

However, the System settings can be saved in the edit screen. Therefore, no changes to the settings are lost, even when the power is turned off.

Setting Parameters

1. Press the [EDIT] button, getting the indicator to light.

The Edit Menu screen appears.

```
EDIT MENU
#System
```

2. Use the [DEC] [INC] buttons to select a menu, then press the [ENTER] button.

```
#Master Tune
      440.0Hz
```

3. Use the [DEC] [INC] buttons to select the parameter to be set, then press the [ENTER] button.

```
Master Tune
#440.0Hz
```

4. Use the [DEC] [INC] buttons to set the value.

If you press the [DEC] button and [INC] button simultaneously, the setting will return to its default value.

5. If you want to save the setting, press the [WRITE] button. Then, press the [ENTER] button.

You can return to Step 3 by pressing the [EXIT/SHIFT] button.

NOTE

Unless they have been saved, these settings are lost when the power is turned off.

6. When you have finished making the settings, press the [EDIT] button, extinguishing its indicator.



The following settings will be stored as common settings for the entire RD-300GX.

- System

Parameters that can be Set

You can set the following parameters in Edit mode.

System	Master Tune	p. 64
	Master Volume	p. 64
	SETUP Pedal Shift	p. 64
	SETUP Control Channel	p. 65
	USB Driver	p. 65
	USB Memory Mode	p. 65
	Damper Pedal Polarity	p. 65
	Control Pedal Polarity	p. 65
	Indicator Mode	p. 65
	Part Mode	p. 66
	Temperament	p. 66
	Temperament Key	p. 66
	Rx GM System ON	p. 67
	Rx GS Reset	p. 67
	Audio Volume	p. 67
Song Stop Mode	p. 67	
Key Touch	Key Touch	p. 62
	Key Touch Offset	p. 62
	Velocity	p. 62
	Velocity Delay Sense	p. 62
	Key Touch Mode	p. 62
Common	MFX Zone	p. 68
	Control Pedal Function	p. 68
	S1 Function	p. 68
	S2 Function	p. 68
Tone Parameter	Attack Time	p. 69
	Release Time	p. 69
	Cutoff Frequency	p. 69
	Resonance	p. 69
	Decay Time	p. 69
	Reverb Amount	p. 69
	Coarse Tune	p. 70
	Fine Tune	p. 70
Bend Range	p. 70	

Detailed Settings for Each Function ([EDIT] Button)

Zone Parameter	Key Transpose	p. 70
	Pan	p. 70
	Damper Pedal Switch	p. 71
	Control Pedal Switch	p. 71
	Bender Switch	p. 71
	Modulation Switch	p. 71
	S1 Switch	p. 71
	S2 Switch	p. 71
Part Switch	Switch	p. 71
File	Save SETUP	p. 72
	Load SETUP	p. 72
	Delete SETUP	p. 73
	Copy SETUP	p. 74
	Delete SONG	p. 75
	Copy SONG	p. 74
	Format	p. 76
Song Function	Play Mode	p. 76
	Playback Transpose	p. 76
	Center Cancel	p. 76
Utility	Rec Mode	p. 78
	Local Control	p. 78
	Bulk Dump	p. 77
	Factory Reset Current Setup	p. 77
	Factory Reset All	p. 77

Making System Settings (System)

Functions that affect the RD-300GX's overall operating environment are called "System functions."

Tuning to Other Instrument's Pitches (Master Tune)

For a cleaner ensemble sound while performing with one or more other instruments, ensure that each instrument's basic pitch is in tune with that of the other instruments. In general, the tuning of an instrument is indicated by the pitch in Hertz (Hz) of the middle "A" note.

Parameter	Value
Master Tune	415.3–440.0–466.2

Adjusting the Volume (Master Volume)

Adjusts the volume of the entire RD-300GX.

Parameter	Value
Master Volume	0–127

Using a Control Pedal to Switch Setups (SETUP Pedal Sft)

You can use a control pedal connected to the CONTROL PEDAL jack to switch between RD-300GX Setups.

Parameter	Value	Description
SETUP Pedal Sft (SETUP Pedal Shift)	OFF	The pedal will perform the function assigned in "Control Pedal Function" (p. 68) of the "COMMON" menu.
	ON	Each time you press the pedal, the Setup will be switched in ascending order. * If you choose this setting, the function assigned in "Control Pedal Function" of the "COMMON" menu will be disabled.

Using Program Change Messages to Switch Setups (SETUP Ctrl Ch.)

You can switch the RD-300GX's Setups with MIDI messages from an external MIDI device.

Set the MIDI Receive channel for receiving the MIDI messages (Program Changes) from the external MIDI device to be used for switching Setups.

When not switching Setups from an external MIDI device, set this to OFF.

Parameter	Value
SETUP Ctrl Ch. (SETUP Control Channel)	1–16, OFF

When the SETUP Control Channel settings are transmitted along with the part's MIDI receive channel, switching of Setups takes priority over the switching of Tones.

NOTE

For more information about switching Setups, refer to "Switching Setups" (p. 80).

Making the Settings for the USB Driver (USB Driver)

If you intend to connect to a computer using the USB connector, you need to make the following setting before you make the connection.

After changing this setting, turn the power off and then on again.

Parameter	Value	Description
USB Driver	ORIGINAL	Select this if you're using the USB driver on the included CD-ROM (Audio Key Utility 2), or a USB driver you downloaded from the Roland website.
	GENERIC	Choose this if you want to use the standard USB driver that was included with your computer.

MEMO

Select the "ORIGINAL" setting if transmission and reception of MIDI data using the standard USB driver included with your computer is too slow.

Changing the USB Memory Setting (USB Memory Mode)

In some cases, when USB memory is connected to the USB MEMORY connector, it may take longer for data to be loaded, or data may fail to be loaded successfully. If this occurs, you may be able to solve the problem by changing the USB memory setting.

After changing this setting, turn the power off and then on again.

Parameter	Value
USB Memory Mode	MODE1, MODE2

Switching the Pedal's Polarity (Damper Polarity/Control Polarity)

Switch the polarity of pedals connected to the RD-300GX.

This can be set individually for each of the Pedal jacks on the rear panel (DAMPER, CONTROL).

On some pedals, the electrical signal output by the pedal when it is pressed or released is the opposite of other pedals. If your pedal has an effect opposite of what you expect, set this parameter to REVERSE.

If you are using a Roland pedal (that has no polarity switch), set this parameter to STANDARD.

Parameter	Value
Damper Polarity	STANDARD, REVERSE
Control Polarity	

Selecting the Indicator Mode (Indicator Mode)

This specifies how the indicators will appear when off.

Parameter	Value	Description
Indicator Mode	NORMAL	The indicator will be lit if a function is on, and will be extinguished if it is off.
	DIMLY	The indicator will be dimly lit when the function is off. This will help you find the location of the buttons even on a dimly lit stage.

Selecting the Number of Parts (Part Mode)

This selects the number of parts for the RD-300GX. When set to "16PART+PERF," the performance on the keyboard is not affected by MIDI messages from the MIDI IN connector or song data played by the RD-300GX. This is useful when you want to perform on the keyboard while playing song data with the RD-300GX. If you select "16PART," the keyboard part you yourself play can use the same part as the song data, meaning that you can specify program changes or bank selections within the song data so that the tone of the keyboard part will be switched automatically.

Parameter	Value
Part Mode	16PART, 16PART+PERF (Performance)

Setting the Tuning Method (Temperament)

This sets the tuning. Most modern songs are composed and played with the assumption that equal temperament will be used, but when classical music was composed, there were a wide variety of other tuning systems in existence. Playing a composition with its original tuning lets you enjoy the sonorities of the chords that the composer originally intended.

Parameter	Value	Description
Temperament	EQUAL	This tuning divides an octave into 12 equal parts. Every interval produces about the same amount of slight dissonance.
	JUST(MAJOR)	This scale eliminates dissonance in fifths and thirds. It is unsuited to playing melodies and cannot be transposed, but is capable of beautiful sonorities.
	JUST(MINOR)	The scales of the major and minor just intonations are different. You can get the same effect with the minor scale as with the major scale.

Parameter	Value	Description
Temperament	PYTHAGOREAN	This scale devised by the philosopher Pythagoras eliminates dissonance in fourths and fifths. Dissonance is produced by third-interval chords, but melodies are euphonious.
	KIRNBERGER	This scale is a modification of the meantone and just intonations that permits greater freedom in transposition to other keys. Performances are possible in all keys (III).
	MEAN TONE	This scale makes some compromises in just intonation, enabling transposition to other keys.
	WERCKMEISTER	This is a combination of the mean tone and Pythagorean scales. Performances are possible in all keys (first technique, III).
	ARABIC	This scale is suitable for Arabic music.

Selecting the Keynote (Temperament Key)

When playing with tuning other than equal temperament, you need to specify the keynote for tuning the song to be performed (that is, the note that corresponds to C for a major key or to A for a minor key). If you choose an equal temperament, there's no need to select a keynote.

Parameter	Value
Temperament Key	C, C#, D, Eb, E, F, F#, G, G#, A, Bb, B

NOTE

When performing in ensemble with other instruments, be aware that depending on the key, there may be some shifting of the pitch. Tune the RD-300GX to the fundamental pitch of the other instruments.

Switching Between Reception of GM/GM2 System On and GS Reset (Rx GM Sys ON, Rx GS Reset)

Specifies whether General MIDI System On, General MIDI 2 System On, or GS Reset messages from external MIDI devices will be received (ON) or not (OFF).

Parameter	Value
Rx. GM Sys ON (Rx GM/GM2 System ON)	ON, OFF
Rx. GS Reset	

Adjusting the Volume of Audio File Playback (Audio Volume)

This adjusts the volume of audio file playback (p. 40) and of the Audio Key function (p. 42).

Parameter	Value
Audio Volume	0-127

Having Song Playback Stop when You Press a ONE TOUCH Button (Song Stop Mode)

This specifies whether the song will stop when you press the ONE TOUCH [PIANO] button while a song is playing.

Parameter	Value	Description
Song Stop Mode	ON	If you press a ONE TOUCH button while a song is playing, the song will stop playing.
	OFF	Even if you press a ONE TOUCH button while a song is playing, the song will not stop playing.

Setting the Keyboard Touch (Key Touch)

You can make advanced settings for the touch used for the keys.



For more on the following key touch function parameters, refer to the corresponding pages.

Key Touch →p. 62

Key Touch Offset →p. 62

Velocity →p. 62

Velocity Delay Sense →p. 62

Key Touch Mode →p. 62

Setup-Related Settings (Common)

Setting the Zone to which Multi Effects are Added (MFX Zone)

This specifies the Zone to which the multi-effect will be applied when you're playing in Dual mode (p. 28) or Split mode (p. 29).

Parameter	Value	Description
MFX Zone	UPPER 1	The effect will be applied to the UPPER 1 Zone.
	UPPER 2	The effect will be applied to the UPPER 2 Zone.
	LOWER	The effect will be applied to the LOWER Zone.



The effect will be applied to Zones that use the same effect as this Zone.

Changing the Pedal Function (Ctrl Pedal Func)

This sets the function of the pedal switch or expression pedal (such as the optional EV-5/7) connected to the CONTROL jack on the rear panel.

Parameter	Value	Function/Parameter Setting Changed
Ctrl Pedal Func (Control Pedal Function)	OFF	No control
	SOFT	Soft Pedal
	SOSTENUTO	Sostenuto pedal
	EXPRESSION	Expression Pedal
	MODULATION	Vibrato will be applied in the same way as when you move the modulation lever.
	BEND UP	The pitch will rise in the same way as when you move the Pitch Bend lever toward the right.
	BEND DOWN	The pitch will fall in the same way as when you move the pitch bend lever toward the left.
AFTERTOUCH	The pedal will control aftertouch.	

Parameter	Value	Function/Parameter Setting Changed
Ctrl Pedal Func	START/STOP	The external sequencer will start/stop.
	TAP TEMPO	The tempo will be modified to the interval at which you press the pedal.
	RHY START/STOP	Starts and stops Rhythms (p. 37).
	SONG START/STOP	Starts and stops a song (p. 40).
	AUDIO KEY SW	This is the same function as the [AUDIO KEY] button. Audio key (p. 42) will be turned on/off.
MFX SW	Performs the same function as the [MULTI EFFECTS] button. Switches the multi-effects (p. 47) on and off.	

Assigning Functions to the [S1] [S2] Buttons (S1/S2 Func)

This setting determines the function of the [S1] and [S2] buttons.

Parameter	Value	Function/Parameter Setting Changed
S1/S2 Func (S1/S2 Function)	OFF	No control
	COUPLE +1OCT	When you play the keyboard, notes one octave above will also sound at the same time.
	COUPLE -1OCT	When you play the keyboard, notes one octave below will also sound at the same time.
	COUPLE +2OCT	When you play the keyboard, notes two octave above will also sound at the same time.
	COUPLE -2OCT	When you play the keyboard, notes two octave below will also sound at the same time.

Parameter	Value	Function/Parameter Setting Changed
S1/S2 Func	COUPLE +5TH	When you play the keyboard, notes a fifth (seven semitones) above will also sound at the same time.
	COUPLE -4TH	When you play the keyboard, notes a fourth (five semitones) below will also sound at the same time.
	OCTAVE UP	Each button press raises the key range in octave steps (up to 4 octaves higher).
	OCTAVE DOWN	Each button press lowers the key range in octave steps (up to 4 octaves lower).
	START/STOP	The external sequencer will start/stop.
	TAP TEMPO	The tempo will be modified to the interval at which you press the button.
	RHY PLAY/STOP	Starts and stops Rhythms (p. 37).
SONG PLAY/STOP	Starts and stops the song (p. 40).	

Resonance: This boosts the portions in the region around the cutoff frequency, lending a particular quality to the sound. Excessively high settings can produce oscillation, causing the sound to distort.

Decay Time: The time it is to take following the attack for the volume to decrease.

NOTE Making abrupt changes in the settings values may cause the sound to become distorted or overly loud. Carefully monitor volume levels while making the settings.

Parameter	Value	Description
Attack Time	-64-0-+63	Higher values produce a milder attack; lower values produce a sharper attack.
Release Time		Higher values produce longer decay; set lower values for a clear-cut sound.
Cutoff Freq		Higher values brighten the sound; lower values make the sound seem darker.
Resonance		Higher value makes the special quality of the sound stronger; lower value reduce these characteristics.
Decay Time		The time it takes for the volume to fall increases as the value is raised; lowering the value decreases the decay time.

NOTE The effect may not be apparent with some Tones, even when the value is changed.

Tone Settings (Tone Parameter)

You can make more detailed settings to the Tones assigned to each of the Zones.



Press the ZONE SELECT button to select the Zone to be set.

Changing Tone Elements (Attack Time/Release Time/Cutoff Freq/Resonance/Decay Time)

You can make changes in tones by adjusting the settings of the following five elements.

Attack Time: The time it takes after the key is pressed for a sound to reach full volume.

Release Time: The time it takes after the key is released for a sound to become inaudible.

Cutoff Freq: Adjusts how much the filter is opened.

Setting the Amount of Reverb Applied to Each Tone (Reverb Amount)

This sets the depth of the reverb effect for each Tone.

NOTE When this value is set to "0," no effect is applied even when the [REVERB] button is pressed.



You can also make the setting by holding down the [REVERB] button and adjusting any of the ZONE LEVEL sliders.

Parameter	Value
Reverb Amount	0-127

Changing the Pitch (Coarse Tune/Fine Tune)

This sets the pitch of the Tone.

Parameter	Value	Description
Coarse Tune	-48--+48 (+/- 4 octaves)	Sets the sound's pitch in semitone units.
Fine Tune	-50--+50 (+/- 50 cents)	Sets the sound's pitch in units of one cent.



1 cent = 1/100 semitone



With some Tones, there may be ranges in which the pitch does not change as intended.

Changing the Bend Range (Bend Range)

This sets the amount of pitch change that will occur when you move the Pitch Bend lever (2 octaves).

Parameter	Value
Bend Range	0-24 (semitone)

Making the Settings for Each Zone Individually (Zone Parameter)

You can make more detailed settings for the Zone.



Press the ZONE SELECT button to select the Zone to be set.

Setting the Transposition for Each Individual Zone (Transpose)

You can perform with each Zone transposed to a different pitch.

When multiple Tones are playing, you can create a richer sound by setting the two Tones to different octaves. Also, if the keyboard mode is set to Split and you are playing a bass Tone in the lower Zone, you can use the Transpose function to play the bass at a lower pitch.

Parameter	Value
Transpose	-48-0--+48



You can also set the same degree of transposition for all parts with the [TRANSCOPE] button. For details, refer to "Transposing the Key of the Keyboard ([TRANSCOPE] Button)" (p. 32).

Setting the Pan (Pan)

Sets the panning (localizes sound image) for each of the Zones.

The Pan setting localizes the sound image of each Zone when the output is in stereo. With an increase in the value for L, more of the sound will be heard as coming from the left side. Similarly, more of the sound will originate at the right if the value of R is increased. When set to 0, the sound is heard as coming from the center.

Parameter	Value
Pan	L64-0-R63

Turning the Controllers in Each Zone On and Off

These settings determine whether the pedals connected to each PEDAL jack (DAMPER, CONTROL), the Modulation lever, the Pitch Bend lever (Bender), and the [S1] [S2] buttons are used to control the Zone (ON), or not (OFF).

Parameter	Value
Damper Pedal Sw	OFF, ON
ControlPedal Sw	
Bender Sw	
Modulation Sw	
S1 Sw	
S2 Sw	

Part On/Off (Part Switch)

Sets the part on or off.

1. Press the [EDIT] button, getting the indicator to light.

The Edit Menu screen appears.

```
EDIT MENU
#System
```

2. Use the [DEC] [INC] buttons to select "Part Switch," then press the [ENTER] button.

```
Part Switch
12345678910111213141516
```

3. While continuing to hold down the [EXIT/SHIFT] button, use the [DEC] [INC] buttons to select the part to be set.
4. Use the [DEC] [INC] buttons to switch the setting to "ON" or "OFF."

The part number is shown for parts that are turned on, and "-" is shown for parts that are turned off.
5. When you have finished making the settings, press the [EDIT] button, extinguishing its indicator.

NOTE

On the RD-300GX, UPPER 1 is fixed as Part 1 (Ch 1), UPPER 2 is fixed as Part 2 (Ch 2), while LOWER is fixed as Part 3 (Ch 3). Note that the keyboard won't produce sound if Parts 1, 2 and 3 are set to OFF.

File Management (File)

The RD-300GX lets you store Setup data in internal memory or in USB memory connected to the USB MEMORY connector on the rear panel.

Saving a Setup File (Save SETUP)

A single, individual file containing a collection of 32 Setups registered to the RD-300GX is called a "Setup file." This Setup file can be saved in the RD-300GX's internal memory or on USB memory (sold separately) connected to the USB MEMORY connector.

1. Press the [EDIT] button, getting the indicator to light.

The Edit Menu screen appears.

2. Use the [DEC] [INC] buttons to select "File," then press the [ENTER] button.

3. Press the [DEC] button to select "Save SETUP," then press the [ENTER] button.

The following screen appears.

```
Select Media
          INT
```

4. Use the [DEC] [INC] buttons to select the destination in which the Setups are to be stored.

Value	Description
INT	The data will be stored in the RD-300GX's internal memory.
USB	The data will be stored on USB memory connected to the USB MEMORY connector on the rear panel.

5. Press the [ENTER] button.

The following screen appears.

```
File Name
[SETUP File ]
```

6. While continuing to hold down the [EXIT/SHIFT] button, use the [DEC] [INC] buttons to move the cursor to the positions where the characters are to be input.

7. Use the [DEC] [INC] buttons to enter the name.

Names can consist of up to 16 characters.

The following characters are available.

space ! # \$ % & ' () + , - . 0-9 ; = @ A-Z [] ^ _ ` a-z { } ~



You can't save a Setup file with a name that starts with a "." (period). Do not use a "." (period) at the beginning of the name.

8. Repeat steps 6-7 to input the name.

9. When you've finished entering the file name, press the [ENTER] button.

The following screen appears.

```
Are you sure?
[EXIT]/[ENTER]
```

If you do not want to save the Setup file, press the [EXIT/SHIFT] button.

10. Press the [ENTER] button once again to save the Setup file.



"Executing..." appears in the display while the save is in progress. Be sure never to turn off the power.

If a file with the same name has already been saved, the confirmation message "Overwrite OK?" appears. To overwrite the file, press the [ENTER] button; to save the file under a different name, press the [EXIT/SHIFT] button.



11. Press the [EDIT] button, extinguishing its indicator.

Calling Up Setup File (Load SETUP)

Here's how to load a previously saved Setup file.



The current settings are erased when a Setup file is called up. Be sure to save you would like to keep first before calling up.

1. Press the [EDIT] button, getting the indicator to light.

The Edit Menu screen appears.

2. Use the [DEC] [INC] buttons to select "File," then press the [ENTER] button.

- Use the [DEC] [INC] button to select "Load SETUP," then press the [ENTER] button.
- Use the [DEC] [INC] buttons to select the memory into which you want to load the data.

Value	Description
INT	The data in the RD-300GX's internal memory will be loaded.
USB	The data on USB memory connected to the USB MEMORY connector on the rear panel will be loaded.

- Press the [ENTER] button.
The following screen appears.

```
File Name
#SETUP File
```

- Use the [DEC] [INC] buttons to select the file you want to call up, then press the [ENTER] button.
The confirmation message appears.

```
Are you sure?
[EXIT]/[ENTER]
```

If you do not want to load the Setup file, press the [EXIT/SHIFT] button.

- Press the [ENTER] button once again to load the Setup file.
The Setup file is loaded into the RD-300GX.

NOTE Be sure never to turn off the power while the load is in progress.

MEMO If you load a file with a name that contains characters that cannot be displayed by the RD-300GX, the file name is displayed as "?."

- Press the [EDIT] button, extinguishing its indicator.

Deleting a Setup File (Delete SETUP)

Here's how to delete a previously saved Setup file.

- Press the [EDIT] button, getting the indicator to light.
The Edit Menu screen appears.
- Use the [DEC] [INC] buttons to select "File," then press the [ENTER] button.
- Use the [DEC] [INC] to select "Delete SETUP," then press the [ENTER] button.
- Use the [DEC] [INC] buttons to select the memory containing the file you want to delete.

Value	Description
INT	The data in the RD-300GX's internal memory will be deleted.
USB	The data on USB memory connected to the USB MEMORY connector on the rear panel will be deleted.

- Press the [ENTER] button.
The following screen appears.

```
File Name
#SETUP File
```

- Use the [DEC] [INC] buttons to select the file that you want to delete, and press the [ENTER] button.

MEMO If you choose "ALL," all Setup files will be deleted.
The confirmation message appears.

```
Are you sure?
[EXIT]/[ENTER]
```

If you do not want to delete the file, press the [EXIT/SHIFT] button.

- Press the [ENTER] button to delete the file.
- Press the [EDIT] button, extinguishing its indicator.

NOTE "Executing..." appears in the display while the deletion is in progress. Be sure never to turn off the power.

Copying a Setup File (Copy SETUP)

You can copy a Setup file from the RD-300GX's internal memory to USB memory (sold separately).

You can also copy a Setup file from USB memory to the RD-300GX's internal memory.

1. Press the [EDIT] button, getting the indicator to light.

The Edit Menu screen appears.

2. Use the [DEC] [INC] buttons to select "File," then press the [ENTER] button.

3. Press the [DEC] [INC] buttons to select "Copy SETUP," then press the [ENTER] button.

The following screen appears.



4. Use the [DEC] [INC] buttons to select the type of copy.

Value	Description
INT->USB	Copy from the RD-300GX's internal memory to USB memory.
USB->INT	Copy from USB memory to the RD-300GX's internal memory.

5. Press the [ENTER] button.

The following screen appears.



6. Use the [DEC] [INC] buttons to select the file that you want to copy, and press the [ENTER] button.

MEMO If you choose "ALL," all Setup files will be copied.

The confirmation message appears.



If you do not want to copy the file, press the [EXIT/SHIFT] button.

7. Press the [ENTER] button once again to copy the file.

8. Press the [EDIT] button, extinguishing its indicator.

NOTE

"Executing..." appears in the display while the copy is in progress. Be sure never to turn off the power.

Copying a Song (Copy SONG)

You can copy a song file from the RD-300GX's internal memory to USB memory (sold separately).

You can also copy a song file from USB memory to the RD-300GX's internal memory.

NOTE

You can't copy audio files.

1. Press the [EDIT] button, getting the indicator to light.

The Edit Menu screen appears.

2. Use the [DEC] [INC] buttons to select "File," then press the [ENTER] button.

3. Press the [DEC] [INC] buttons to select "Copy SONG," then press the [ENTER] button.

The following screen appears.



4. Use the [DEC] [INC] buttons to select the type of copy.

Value	Description
INT->USB	Copy from the RD-300GX's internal memory to USB memory.
USB->INT	Copy from USB memory to the RD-300GX's internal memory.

5. Press the [ENTER] button.

The following screen appears.



6. Use the [DEC] [INC] buttons to select the file that you want to copy, and press the [ENTER] button.

MEMO

If you choose "ALL," all song files will be copied.

7. Press the [ENTER] button.

The confirmation message appears.



If you do not want to copy the file, press the [EXIT/SHIFT] button.

8. Press the [ENTER] button once again to copy the file.

9. Press the [EDIT] button, extinguishing its indicator.

"Executing..." appears in the display while the copy is in progress. Be sure never to turn off the power.

NOTE

Deleting a Song (Delete SONG)

This operation deletes a saved song.

1. Press the [EDIT] button, getting the indicator to light.

The Edit Menu screen appears.

2. Use the [DEC] [INC] buttons to select "File," then press the [ENTER] button.

3. Use the [DEC] [INC] to select "Delete SONG," then press the [ENTER] button.

4. Use the [DEC] [INC] buttons to select the memory containing the file you want to delete.

Value	Description
INT	The data in the RD-300GX's internal memory will be deleted.
USB	The data on USB memory connected to the USB MEMORY connector on the rear panel will be deleted.

5. Press the [ENTER] button.

The following screen appears.



6. Use the [DEC] [INC] buttons to select the file that you want to delete, and press the [ENTER] button.

MEMO

If you choose "ALL," all song files will be deleted.

The confirmation message appears.



If you do not want to delete the file, press the [EXIT/SHIFT] button.

7. Press the [ENTER] button to delete the song.

8. Press the [EDIT] button, extinguishing its indicator.

"Executing..." appears in the display while the deletion is in progress. Be sure never to turn off the power.

NOTE

Formatting Memory (Format)

“Formatting” is the operation of returning the RD-300GX’s internal memory to its factory-set state, or the operation of preparing USB memory for use with RD-300GX.

USB memory cannot be used with the RD-300GX unless it is formatted suitably for the RD-300GX.

If you’re using newly purchased USB memory, you must first format it on the RD-300GX.

When you format the USB memory, all data previously saved on that memory will be erased.

NOTE Before you carry out a format, make sure that the USB memory does not contain important data you need to keep.

1. Press the [EDIT] button, getting the indicator to light.
The Edit Menu screen appears.
2. Use the [DEC] [INC] buttons to select “File,” then press the [ENTER] button.
3. Press the [DEC] [INC] buttons to select “Format,” then press the [ENTER] button.
4. Use the [DEC] [INC] buttons to select the media that you want to format.

Value	Description
INT	The RD-300GX’s internal memory will be formatted.
USB	The USB memory connected to the USB MEMORY connector on the rear panel will be formatted.

5. Press the [ENTER] button.

The confirmation message appears.

Are you sure?
[EXIT]/[ENTER]

If you do not want to format the media, press the [EXIT/SHIFT] button.

6. Press the [ENTER] button once again to execute the Format operation.
All the contents of the memory will be erased.
7. Press the [EDIT] button, extinguishing its indicator.

NOTE “Executing...” appears in the display while the format is in progress. Be sure never to turn off the power.

NOTE Don’t remove the USB memory until formatting is completed.

Settings Related to Song Playback (Song Function)

You can change a variety of settings related to song playback. (p. 40)

Selecting the Song Playback Method (Play Mode)

When playing songs on the RD-300GX, you can choose whether to play songs individually or play all songs successively.

Parameter	Value	Description
Play Mode	ONE SONG	When you play back a song, only one song will play; playback will stop at the end of that song.
	ALL SONG	The songs in internal memory or in USB memory will play consecutively.

Changing the Key of the Song Playback (Playback Trans)

This lets you shift the playback key of a song in semitone steps. This also applies to Audio Key playback (p. 42).

Parameter	Value
Playback Trans (Playback Transpose)	-6-0+5

Performing Along with a Audio File (Center Cancel)

When playing back audio files, this causes sounds located in the center (e.g., vocals or melodic instruments) to be reduced in volume.

This also applies to Audio Key playback (p. 42).

Parameter	Value
Center Cancel	OFF, ON

NOTE For some songs, using the Center Cancel function may affect the tonal character.

Utility Settings (Utility)

Utility includes functions for sending data to external MIDI sequencers and other devices and for restoring the settings to their original factory state.



For more on "Rec Mode" and "Local Control" in Utility menu, refer to "Settings for Recording (Rec Mode/Local Control)" (p. 78).

Transferring the RD-300GX's Settings to an External MIDI Device (Bulk Dump)

You can transfer the contents of a Setup to an external MIDI device. This operation is called "bulk dump."

The RD-300GX lets you send the contents of the currently selected Setup to an external MIDI device. This is convenient when you're recording a song.

1. Use a MIDI cable (optional) to connect the RD-300GX's MIDI OUT connector to the MIDI IN connector on an external sequencer.
 2. Press the [EDIT] button, getting the indicator to light.
The Edit Menu screen appears.
 3. Press the [INC] button to select "Utility," then press the [ENTER] button.
 4. Use the [DEC] [INC] buttons to select "Bulk Dump," then press the [ENTER] button.
The following screen appears.
- [Piano&Choir] Currently selected Setup name
Send OK?
5. Put the external sequencer in record mode.
 6. Press the [ENTER] button to transmit the settings.
The message "Executing..." appears in the display during transmission of the data.
 7. After the transmitting is finished, the display will indicate "Completed."
You are returned to the Edit screen.
 8. Stop the external sequencer.

Restoring the Settings to the Factory Condition (Factory Reset)

The settings stored in the RD-300GX can be returned to their factory settings.



Executing "Factory Reset All" results in deletion of the Setups (p. 50). If you want to keep the recorded content, save the Setup file to your USB memory (p. 72).



When making USB connections, be absolutely sure to disconnect the USB cable before starting.

1. Press the [EDIT] button, getting the indicator to light.
The Edit Menu screen appears.
2. Press the [INC] button to select "Utility," then press the [ENTER] button.
3. Use the [DEC] [INC] buttons to select "Fctry Reset Cur" or "Fctry Reset All," then press the [ENTER] button.

Parameter	Description
Fctry Reset Cur	The currently selected Setup returned to their factory settings.
Fctry Reset All	The settings stored in the RD-300GX can be returned to their factory settings.

The following screen appears.



To cancel the Factory Reset, press the [EXIT/SHIFT] button.

4. Press the [ENTER] button once again to start the Factory Reset operation.



"Executing..." appears in the display while the Factory Reset is in progress. Be sure never to turn off the power.

After the Factory Reset operation is finished, The Utility screen returns to the display.



While the Factory Reset is in progress, no sounds are produced even when the keys are pressed. In addition, song, and Rhythms being played are also stopped.

Connecting External MIDI Devices

Recording RD-300GX Performances to an External MIDI Sequencer

Now, try using an external sequencer to record your music onto multiple tracks, and then play back the recorded performance.

Connecting to an External Sequencer

NOTE

To prevent malfunction and/or damage to speakers or other devices, always turn down the volume, and turn off the power on all devices before making any connections.

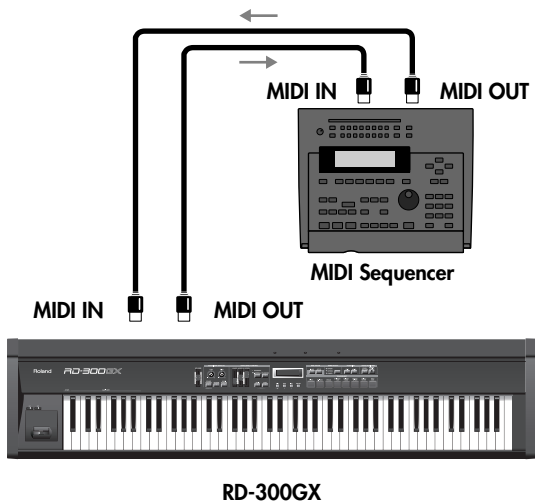

1. Before starting the connection procedure, make sure that the power to all devices has been turned off.
2. After reading "Connecting the External Equipment to RD-300GX" (p. 17), connect an audio device/system or headphones.
3. Connect the external MIDI sequencer with the MIDI cable as shown in the figure above.
4. As described in "Turning On the Power" (p. 19), turn on the power of each device.

Settings for Recording (Rec Mode/Local Control)

"Rec Mode" and "Local Control" are convenient features to use when recording to an external sequencer.

When using the functions, you can get the most suitable settings for recording the RD-300GX's data to an external sequencer, without having to make all the Part and channel settings.

1. Press the [EDIT] button, getting the indicator to light.
The Edit Menu screen appears.
2. Press the [INC] button to select "Utility," then press the [ENTER] button.
3. Use the [DEC] [INC] buttons to select the parameter to be set, then press the [ENTER] button.



4. Use the [DEC] [INC] buttons to switch the setting to "ON" or "OFF."

Parameter	Value	Description
Rec Mode	ON, OFF	Ordinarily this will be set to OFF. When this is set to ON, settings appropriate for recording are used with respect to the output from MIDI OUT, regardless of the Internal Zone settings.
	Local Control	This switches the Local Switch on and off. Although normally set to ON, it should be set to OFF when recording. For details, refer to the following section "About the Local Switch" (p. 79).

You can return to Step 3 by pressing the [EXIT/SHIFT] button.

5. When you have finished making the settings, press the [EDIT] button, extinguishing its indicator.

With Rec Mode set to ON, you cannot change the External Zone settings (p. 79). Pressing the [EXTERNAL/INTERNAL] button does not call up the External screen when Rec Mode is set to ON.

NOTE

Recording the Performance

Use the following procedure when recording to an external sequencer.

- 1. Turn on the external sequencer's Thru function.**
For details, refer to the following section "About Local Switch."
Refer to your sequencer owner's manual for instructions on how to carry out this procedure.
- 2. Select the Setup for the performance to be recorded.**
For instructions on selecting the Setup, refer to p. 50.
- 3. Set the Rec Mode and the Local Control.**
Use the procedure described in the previous section "Settings for Recording" to make the following settings.
Rec Mode: ON
Local Control: OFF
- 4. Begin recording with the external sequencer.**
- 5. Bulk Dump the Setup.**
Using the Utility "Bulk Dump" in Edit mode, transmit the contents of the selected Setup to the external sequencer. For instructions on carrying out this operation, refer to "Transferring the RD-300GX's Settings to an External MIDI Device (Bulk Dump)" (p. 77).
- 6. Perform on the RD-300GX.**
- 7. When the performance is finished, stop recording with the external sequencer.**
Recording is now complete.
You can then listen to the recorded performance by playing it back on the external sequencer.

NOTE

Set "Part Mode" to "16PART" in Edit mode when you use the Multi-Effect settings. (p. 66)

Exiting Rec Mode

When Rec Mode is set to ON, you cannot change the External settings. When you have finished recording the performance, use the procedure described in the previous section "Settings for Recording" to set Rec Mode to OFF.

NOTE

The Rec Mode and Local Control settings cannot be saved. The settings automatically switch to "Rec Mode: OFF, Local Control: ON" when the power is turned on.

About the Local Switch

The switch that connects and disconnects the MIDI connection between the keyboard controller section and the sound generator section (p. 22) is called the Local switch. Since essential information describing what is being played on the keyboard won't reach the sound generator if the Local switch is set to OFF, the Local switch should normally be left ON. However, if while performing you want to send that performance data to an external sequencer as MIDI messages to be recorded, you then perform with the externally connected MIDI sequencer set to MIDI Thru (whereby data received from MIDI IN is then output from the MIDI OUT with no changes made to the data).

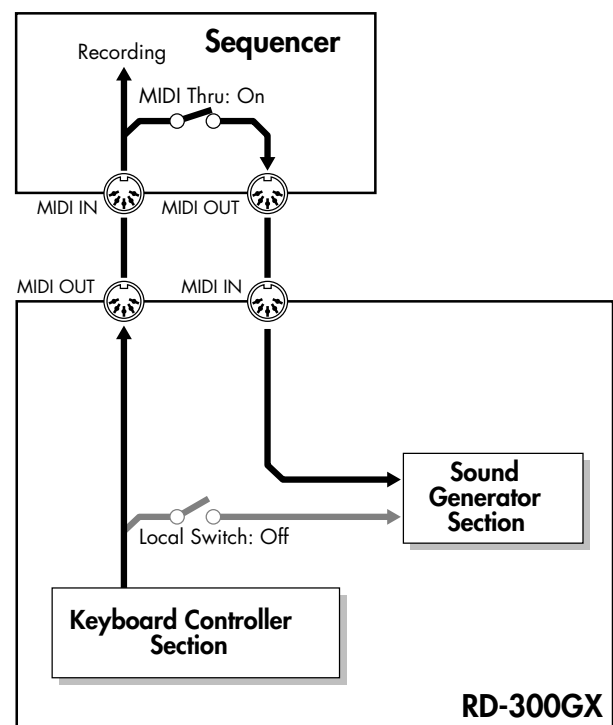

In this case, the data sent over two paths, i.e., the data sent directly from the keyboard controller section and the data sent from the keyboard controller section via the external sequencer, ends up being sent to the sound generator section simultaneously. Thus, for example, even when you play a "C" key only once, the note "C" cannot be sounded correctly, as the sound is played by the sound generator section twice.

Playing the RD-300GX's Internal Sound Generator from an External MIDI Device

Try Playing the RD-300GX from an external MIDI Device.

Making Connections

NOTE

To prevent malfunction and/or damage to speakers or other devices, always turn down the volume, and turn off the power on all devices before making any connections.

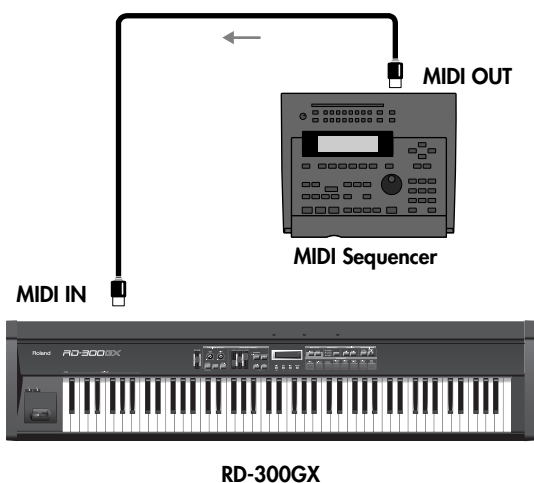

1. Before starting the connection procedure, make sure that the power to all devices has been turned off.
2. After reading "Connecting the External Equipment to RD-300GX" (p. 17), connect an audio device/system or headphones.
3. Connect the external MIDI device with the MIDI cable as shown in the figure above.
4. As described in "Turning On the Power" (p. 19), turn on the power of each device.

Selecting RD-300GX Sounds from an External MIDI Device

Transmitting Bank Select (Controller Number 0, 32) and Program Change messages from the external MIDI device to the RD-300GX allows you to switch Setups and Tones.

Switching Setups

The MIDI messages transmitted by the external MIDI device will be received by the RD-300GX to select Setups as shown in the following table.

Setup Number	Bank Select		Program Change Number
	MSB	LSB	
1-32	85	0	1-32

When switching Setups, you must match the MIDI channel of the transmitting device with the RD-300GX's Control channel (p. 65).

When switching the tones in each part, match the MIDI channel of the transmitting device with the RD-300GX's Receive channel. However, when the Control channel and the Receive channel are both set to the same channel, the Control channel takes priority, and Setups are switched.

MEMO

The RD-300GX does not allow you to change the MIDI channels of the parts. Parts 1-16 are fixed at MIDI channels 1-16, respectively.

Connecting to Your Computer

Connecting to a Computer via the USB MIDI Connector

If you use a USB cable (commercially available) to connect the USB MIDI connector located on the RD-300GX's rear panel to the USB connector of your computer, you'll be able to do the following things.

- Use the RD-300GX to play SMF music files played back by MIDI-compatible software.
- By transferring MIDI data between the RD-300GX and your sequencer software, you'll be able to enjoy a wide range of possibilities for music production and editing.

Connect the RD-300GX to your computer as shown below.

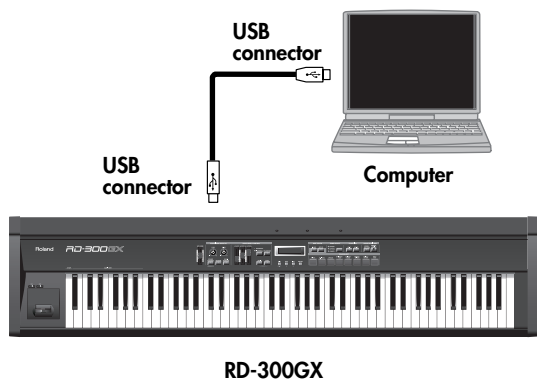

Refer to the Roland website for system requirements.

NOTE

Roland website: <http://www.roland.com/>

Depending on the type of computer you're using, this may not operate correctly.

NOTE

For details on supported operating systems, refer to the Roland website.

Caution

- To avoid the risk of malfunction and/or speaker damage, always make sure to turn the volume all the way down and turn off the power on all equipment before you make any connections.
- Only MIDI data can be transmitted and received via USB.
- A USB cable is not included. If you need to obtain one, ask the dealer where you purchased the RD-300GX.
- Switch on power to the RD-300GX before you start up the MIDI application on your computer. Don't turn the RD-300GX's power on/off while your MIDI application is running.

Specify the USB driver you want to use, and then install the driver. For details, refer to "Making the Settings for the USB Driver (USB Driver)" (p. 65).

The correct driver and the installation procedure will depend on your system and on the other programs you are using. Be sure to read the Readme file on the CD-ROM before installation.

What is the USB MIDI Driver?

The USB MIDI Driver is a software which passes data between the RD-300GX and the application (sequencer software, etc.) that is running on the USB-connected computer.

The USB MIDI Driver sends data from the application to the RD-300GX, and passes data from the RD-300GX to the application.

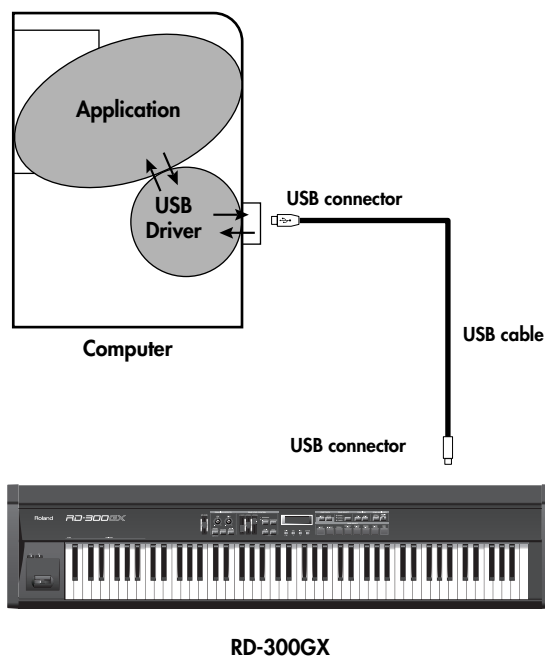

About V-LINK

Connecting the RD-300GX to a V-LINK compatible image device allows you to control the images with the RD-300GX.

NOTE To prevent malfunction and/or damage to speakers or other devices, always turn down the volume, and turn off the power on all devices before making any connections.

V-LINK

V-LINK (**V-LINK**) is functionality promoted by Roland that allows linked performance of music and visual material. By using V-LINK-compatible video equipment, visual effects can be easily linked to, and made part of the expressive elements of a performance.

How to Use the V-LINK

1. Hold down the [EXIT/SHIFT] button and press the [SOUND CONTROL] button.

The upper right of the display will indicate , and the RD-300GX will be in video control mode.

You can control images using the twelve keys at the left end of the keyboard.

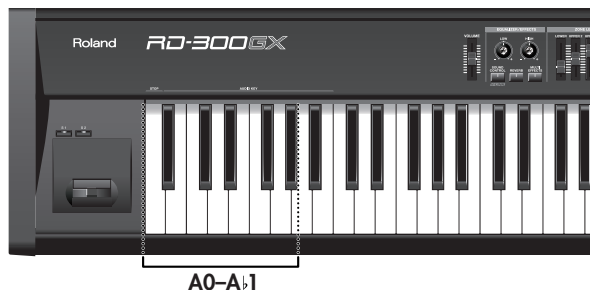

NOTE While V-LINK is switched on, no sound is produced when you press any of the twelve keys at the left end of the keyboard.

2. Hold down the [EXIT/SHIFT] button and press the [SOUND CONTROL] button once again to exit.

The  indication will go out, and V-LINK will turn off.

NOTE Depending on the screen that is displayed, there will be cases in which the  indication does not appear even though V-LINK is on.

Troubleshooting

If the RD-300GX does not function in the way you expect, first check the following points. If this does not resolve the problem, consult your dealer or a nearby Roland Service Station.

* If certain messages appear in the display during operation, please refer to "Error Messages/Other Messages" (p. 86).

Problem	Check/Solution	Page
Power Not Coming On	Is the power cord properly connected?	p. 16
No Sound	Is the volume level of the RD-300GX or connected device turned all the way down?	p. 20
	Are all connections properly made? • When using the RD-300GX as a stand-alone instrument, be sure to connect with audio cables or use headphones.	p. 17
	Are sounds audible with headphones connected? • If sounds are audible through headphones, it may indicate that there is a short in an audio cable or some sort of amp or mixer problem. Check the cables and equipment once again.	—
	Is a Zone level turned off with the ZONE LEVEL sliders?	p. 31, p. 57
	Is the Part setting set to OFF?	p. 71
	If the sound for a pressed key is not being played, is the Local Control set to OFF? • Set the Local Control to ON.	p. 78
	Are the effect settings correct? • Check the ON/OFF settings for the [MULTI EFFECTS] button, MFX Zone and level settings.	p. 47, p. 68
Has the volume been lowered by pedal operations or by MIDI messages (volume messages or expression messages) received from an external MIDI device?	—	
No Sound for Specific Zone	Is the Zone's volume level turned down? • Check the ZONE LEVEL sliders.	p. 31, p. 57
No Sound From the Connected MIDI Device	Is the device enabled to transmit MIDI messages? • Set the [EXTERNAL/INTERNAL] button to "EXTERNAL." MIDI messages cannot be transmitted if the [EXTERNAL/INTERNAL] button is set to "INTERNAL."	p. 55
	Is the RD-300GX's keyboard controller section MIDI Transmit channel matched to the connected MIDI device's MIDI Receive channel? • Make the Ch settings.	p. 55
	Is the power to all devices turned on?	—
	Is the MIDI cable connected and plugged in correctly?	—
No Sound From the Left Side	Is V-LINK switched on? When V-LINK is switched on, the twelve keys at the left end of the keyboard are used to control images, and no sounds are played with these keys.	p. 82
No Sound in a Specific Range	With certain Tones, for example Rhythm Sets, bass Tones, Timpani, and other Tones will not sound if a portion of the Tone falls outside the recommended range.	—
Not All Sounds Are Played	The RD-300GX has a maximum polyphony of 128 voices. When playing together with a song or Rhythm along with heavy use of the damper pedal, the performance data may exceed the number of available voices, and as a result, some notes or sounds played on the keyboard may not sound.	—
Not all keyboard performance data could be processed	Could you be playing back an MP3 file, or changing the playback tempo of an audio file? The following measures may solve the problem. • Use WAV/AIFF format data rather than MP3 format data • Return the song tempo to its original setting (to 0%)	p. 41

Troubleshooting

Problem	Check/Solution	Page
Tones are Altered	Did you call up a Setup? <ul style="list-style-type: none"> When a Setup is called up, the current Tone, effect, and other settings are disabled, and the selected Setup goes into effect. Save the required settings to a Setup. 	p. 50, p. 51
	Did you press the ONE TOUCH [PIANO] button? <ul style="list-style-type: none"> When the ONE TOUCH [PIANO] button is pressed, the current Tone, effect, and other settings are disabled, and settings for use in piano performances go into effect. Save the required settings to a Setup. 	p. 26, p. 51
	When a mono connection is used, the tone quality of some sounds may change, depending on the type of sound and the register in which it is used. To enjoy the best quality when listening to such sounds, we recommend connecting in stereo.	—
Two Sounds are Produced When the Keyboard is Played	Is the RD-300GX in Dual Play?	p. 28
	When the RD-300GX is connected to an external sequencer, set it to the Local OFF mode. Alternatively, set SOFT THRU on the sequencer to "OFF."	p. 78
Tone Doesn't Change	Is the [EXTERNAL/INTERNAL] button to "EXTERNAL"? <ul style="list-style-type: none"> When the [EXTERNAL/INTERNAL] button is set to "EXTERNAL," the external sound generator is controlled. To change the RD-300GX's Tones, set the [EXTERNAL/INTERNAL] button to "INTERNAL." 	p. 55
	Is the ZONE SELECT button for the Zone containing the Tone you want to change set to ON?	p. 31
Effects Not Applied/ Effects Sound Wrong	Is the [MULTI EFFECTS] button set to OFF?	p. 47
	Could the Effect Type be set to 0?	p. 48
	Could the Effect Level be set to 0?	p. 47
	On the RD-300GX, only one type of multi-effect can be used at a time. For this reason, there's a "MFX Zone" setting that lets you choose the Zone to which the multi-effect is to be applied. Be aware that if you're playing more than one Zone simultaneously, there will be a Zone to which the multi-effect is not applied.	p. 68
Reverb Remains Even After Reverb is Lifted	As the RD-300GX piano sounds faithfully reproduce the depth and reverberation of actual acoustic pianos, reverberation may still be audible even after the reverb effect is removed from sounds.	—
Sound Suddenly Changes at Key in Upper Octaves	With the acoustic piano settings, sounds in the upper 1 1/2-octave range are extended to the end regardless of the damper pedal actions. The tone is also different in this range. Roland's pianos faithfully reproduce the sonic qualities of acoustic pianos. Furthermore, you can use the instrument's Key Transpose setting to change that range over which the damper pedal has no effect.	—
Sounds Come From Left or Right Each Time Key is Pressed (Panned)	In some Tones, the settings are such that sounds randomly play from the left or right side (are panned) each time the keys are pressed. These settings cannot be changed.	—
Sound is Distorted	Sounds can be distorted due to master volume, equalizer, multi-effect, and Part volume settings. Adjust the ZONE LEVEL sliders or "Master Volume" setting in the Edit mode.	p. 31, p. 57, p. 64
	Is a distortion-type effect being applied to the sound?	p. 48

Problem	Check/Solution	Page
Pitch is Odd	Depending on the Tone selected, pitches played in certain registers will be changed and played at other pitches.	—
	Have you set Transpose?	p. 32, p. 70, p. 76
	Has the RD-300GX gone out of tune? • Check the System Master Tune settings in Edit mode.	p. 64
	Has the pitch been changed by pedal operations or by Pitch Bend messages received from an external MIDI device?	—
Sound is Cut Off	When you try playing more than the maximum 128 voices simultaneously, sounds currently being played may be cut out.	—
Sound Keeps Playing When Key is Pressed	Is the hold pedal polarity reversed? • Check the System Damper Pedal Polarity settings in Edit mode.	p. 65
Song Data Not Played Back Correctly	Is the Receive GM/GM2 System On Switch set to ON? • Set the System Rx GM System On or System Rx GM2 System On to ON in Edit mode.	p. 67
	Are you playing back GS Format song data? • Once the RD-300GX receives a GS Reset message, it then is enabled for GS Format. This permits playback of music files bearing the GS logo (GS music files). However, data created exclusively for the Sound Canvas Series may not play back properly on the RD-300GX.	—
	Is the audio file in a format supported by the RD-300GX? • Audio file of the following format be played back. WAV/AIFF • Sampling Rate: 44.1 kHz • Bit rate: 16 bit MP3 • Format: MPEG-1 audio layer 3 • Sampling Rate: 44.1 kHz • Bit rate: 32/40/48/56/64/80/96/112/128/160/192/224/256/320 kbps, VBR (Variable Bit Rate)	—
Pedal Has No Effect, or Effect “Sticks”	Is the pedal connected correctly? • Connect the pedal securely to the PEDAL jack.	p. 18
	Are you using a pedal made by another manufacturer? • Use the pedal included with the RD-300GX or an optional DP Series or similar pedal.	—
	Unplugging a pedal cord from the unit while the power is on may cause the pedal’s effect to be applied nonstop. Be sure to switch off the power to the unit before attempting to disconnect or connect a pedal cord.	p. 19
	When Setup Pedal Shift is set to ON and the pedal is being used as a dedicated Setup switch, the control pedal function cannot be used.	p. 64, p. 68
High-Pitched Whine is Produced	When listening through headphones: Certain piano tones that feature vibrant, sparking sounds contain a large high-frequency component, which may make it appear that a metallic reverberation has been applied. This faithfully reproduces the characteristics of acoustic pianos, and does not indicate any malfunction. Since this reverberation becomes particularly audible when supplemented by heavy reverb, you may be able to diminish the problem by reducing the amount of reverb applied to the sound. When listening through speakers: Here, a different cause (such as resonance produced by the RD-300GX) would be suspect. Consult your Roland dealer or nearest Roland Service Center.	—

Error Messages/Other Messages

Error Messages

Indication	Situation	Action
Error 02 File Error	An error occurred during writing. The external media's protect tab may be in the "Protect" (writing prohibited) position, or the external media may not yet be initialized.	---
Error 10 No Storage Media	No external media is inserted.	Insert the external media and try again.
Error 11 File Error	There is not sufficient free memory in the save destination.	Delete unneeded files (Songs or Setup files) you've saved in internal or external memory and try again.
Error 14 File Error	An error occurred during writing. The external media may be corrupted.	Insert other external media and try again. Alternatively, you can initialize the external media.
Error 15 File Error	The file is unreadable. The data format is not compatible with the RD-300GX.	Only files in the following formats can be used. <ul style="list-style-type: none"> • Setup files with an extension of "RDS" • SMF music files with an extension of "MID" • Audio files with an extension of "WAV," "AIF," or "MP3" For details on audio file formats, refer to "Song Data Not Played Back Correctly" (p. 85)
Error 16 File Error	Data was not called up in time for playback of the song.	You may be able to play the song after waiting a few seconds.
Error 18 File Error	This audio format is not supported.	Please use 44.1 kHz 16-bit linear WAV/AIFF format audio file or MP3.
Error 30 File Error	The internal memory capacity of the RD-300GX is full.	You can't fast-forward or rewind the song. Only playback is possible.
Error 40 MIDI Buffer Full	Due to an inordinate volume of MIDI messages received, the RD-300GX has failed to process them properly.	Reduce the amount of MIDI messages to be transmitted.
Error 41 MIDI Commu Error	A MIDI cable has been disconnected.	Connect it properly and securely.
Error 43 MIDI Commu Error	A MIDI transmission error has occurred.	Check the MIDI cable and connected MIDI device.
Error 51 System Error	There may be a problem with the system.	Turn on the power once again, then repeat the procedure.
Error 65 USB Over Current	The USB memory port was subjected to excessive current.	Make sure that there is no problem with the USB memory, then turn the power off, then on again.

Other Messages

Indication	Situation	Action
Unavailable Now, Rec Mode	This is displayed when the [EXTERNAL/INTERNAL] button is pressed with Rec Mode "ON."	When Rec Mode is "ON," you cannot change the External settings. To make changes to the External settings, set Rec Mode to "OFF" (p. 78).
"File name" Overwrite OK?	A file with the same name is already exists.	If you execute the procedure, the file will be overwrite. If you don't want to overwrite, change a filename.
Can not Copy	<ul style="list-style-type: none"> • You attempted to copy an audio file • You attempted to copy a file to USB memory even though USB memory was not connected 	<ul style="list-style-type: none"> • You can't copy audio files • Connect USB memory
Panel is Locked	Buttons will not function.	Press the [EXIT/SHIFT] button to cancel.

Effect List

Indicated number	MFX Type	Overview	Effect parameter name when changed by holding down [MULTI EFFECTS] and pressing [INC] or [DEC] (p. 29): An overview thereof (Value)
00	THRU	—	—
01	EQUALIZER	Amplifies the low and high ends for a noticeably striking tone.	EQ Gain: Gain of the low and high range (-15db--+15db)
02	MID CUT	Cuts the midrange for a clean, refreshing tone.	Mid Gain: Gain of the middle range (-15db--+15db)
03	LOW CUT	Reduces the volume of the low end.	Low Gain: Gain of the low range (-60db--+4db)
04	LOW BOOST	Boosts the volume of the lower range, creating powerful lows.	Boost Gain: Amount by which the lower range will be boosted (0db--+12db)
05	NOTCH FILTER	This filter cuts specific frequencies.	Filter Cutoff: Cutoff frequency of the filter (0-127)
06	STEP FILTER	This filter changes the cutoff frequency in a stepped fashion.	Rate: Rate of modulation (0.05-10.00 Hz)
07	ENHANCER	Controls the overtone structure of the high frequencies, adding sparkle and tightness to the sound.	Sens: Sensitivity of the enhancer (0-127)
08	AUTO WAH	Cyclically controls a filter to create cyclic change in timbre.	Manual: Adjusts the center frequency at which the effect is applied (0-127)
09	HUMANIZER	Adds a vowel character to the sound, making it similar to a human voice.	Rate: Frequency at which the two vowels switch (0.05-10.00 Hz)
10	SPEAKER SIMULATOR	Simulates the large triple stack speaker	Direct Level: Volume of the direct sound (0-127)
11	PHASER	This is a stereo phaser. A phase-shifted sound is added to the original sound and modulated.	Rate: Frequency of modulation (0.05-10.00 Hz)
12	STEP PHASER	This is a stereo phaser. The phaser effect will be varied gradually.	Step Rate: Frequency of modulation (0.10-20.00 Hz)
13	MULTI PHASER	Extremely high settings of the phase difference produce a deep phaser effect.	Rate: Frequency of modulation (0.05-10.00 Hz)
14	INFINITE PHASER	A phaser that continues raising/lowering the frequency at which the sound is modulated.	Speed: Speed at which to raise or lower the frequency at which the sounds modulated (-100--+100)
15	RING MODULATOR	This is an effect that applies amplitude modulation (AM) to the input signal, producing bell-like sounds.	Frequency: Adjusts the frequency at which modulation is applied (0-127)
16	STEP RING MODULATOR	A ring modulator that cyclically changes the modulated frequencies.	Rate: Rate of modulation (0.05-10.00 Hz)
17	TREMOLO	Cyclically modulates the volume to add tremolo effect to the sound.	Rate: Frequency of the change (0.05-10.00 Hz)
18	AUTO PAN	Cyclically modulates the stereo location of the sound.	Rate: Frequency of the change (0.05-10.00 Hz)
19	STEP PAN	Cyclically modulates the stereo location of the sound.	Rate: Frequency of the change (0.05-10.00 Hz)
20	SLICER	By applying successive cuts to the sound, this effect turns a conventional sound into a sound that appears to be played as a backing phrase. This is especially effective when applied to sustain-type sounds.	Rate: Frequency of the change (0.05-10.00 Hz)
21	ROTARY	The Rotary effect simulates the sound of the rotary speakers often used with the electric organs of the past.	Speed: Rotational speed of the rotating speaker (Slow/Fast)
22	VK ROTARY	This type provides modified response for the rotary speaker, with the low end boosted further.	Speed: Rotational speed of the rotating speaker (Slow/Fast)
23	CHORUS	This is a stereo chorus.	Depth: Depth of modulation (0-127)
24	FLANGER	This is a stereo flanger. It produces a metallic resonance that rises and falls like a jet airplane taking off or landing.	Depth: Depth of modulation (0-127)

Effect List

Indicated number	MFX Type	Overview	Effect parameter name when changed by holding down [MULTI EFFECTS] and pressing [INC] or [DEC] (p. 29): An overview thereof (Value)
25	STEP FLANGER	This is a flanger in which the flanger pitch changes in steps.	Step Rate: Rate of pitch change (0.10–20.00 Hz)
26	HEXA-CHORUS	Uses a six-phase chorus to give richness and spatial spread to the sound.	Balance: Volume balance between the direct sound and the chorus sound (D100:0W–D0:100W)
27	TREMOLO CHORUS	This is a chorus effect with added Tremolo (cyclic modulation of volume).	Balance: Volume balance between the direct sound and the tremolo chorus sound (D100:0W–D0:100W)
28	SPACE-D	This is a multiple chorus that applies two-phase modulation in stereo. It gives no impression of modulation, but produces a transparent chorus effect.	Balance: Volume balance between the direct sound and the chorus sound (D100:0W–D0:100W)
29	3D CHORUS	This applies a 3D effect to the chorus sound. The chorus sound will be positioned 90 degrees left and 90 degrees right.	Balance: Volume balance between the direct sound and the chorus sound (D100:0W–D0:100W)
30	3D FLANGER	This applies a 3D effect to the flanger sound. The flanger sound will be positioned 90 degrees left and 90 degrees right.	Balance: Volume balance between the direct sound and the flanger sound (D100:0W–D0:100W)
31	3D STEP FLANGER	This applies a 3D effect to the step flanger sound. The flanger sound will be positioned 90 degrees left and 90 degrees right.	Step Rate: Rate of pitch change (0.10–20.00 Hz)
32	2BAND CHORUS	A chorus effect that lets you apply an effect independently to the low-frequency and high-frequency ranges.	Balance: Volume balance of the original sound and chorus sound (D100:0W–D0:100W)
33	2BAND FLANGER	A flanger that lets you apply an effect independently to the low-frequency and high-frequency ranges.	Balance: Volume balance of the original sound and flanger sound (D100:0W–D0:100W)
34	2BAND STEP FLANGER	A step flanger that lets you apply an effect independently to the low-frequency and high-frequency ranges.	Balance: Volume balance of the original sound and flanger sound (D100:0W–D0:100W)
35	OVERDRIVE	Creates a soft distortion similar to that produced by vacuum tube amplifiers.	Level: Output Level (0–127)
36	DISTORTION	Produces a more intense distortion than Overdrive.	Level: Output Level (0–127)
37	VS OVERDRIVE	This is an overdrive that provides heavy distortion.	Level: Output Level (0–127)
38	VS DISTORTION	This is a distortion effect that provides heavy distortion.	Level: Output Level (0–127)
39	GUITAR AMP SIMULATOR	This is an effect that simulates the sound of a guitar amplifier.	Input Volume: Pre amp input volume (0–127)
40	COMPRESSOR	Flattens out high levels and boosts low levels, smoothing out fluctuations in volume.	Threshold: Adjusts the volume at which compression begins (0–127)
41	LIMITER	Compresses signals that exceed a specified volume level, preventing distortion from occurring.	Threshold: Adjusts the volume at which compression begins (0–127)
42	GATE	Cuts the reverb's delay according to the volume of the sound sent into the effect. Use this when you want to create an artificial-sounding decrease in the reverb's decay.	Threshold: Volume level at which the gate begins to close (0–127)
43	DELAY	This is a stereo delay.	Balance: Volume balance between the direct sound and the delay sound (D100:0W–D0:100W)
44	LONG DELAY	A delay that provides a long delay time.	Balance: Volume balance between the direct sound and the delay sound (D100:0W–D0:100W)
45	SERIAL DELAY	This delay connects two delay units in series.	Balance: Volume balance between the direct sound and the delay sound (D100:0W–D0:100W)
46	MODULATION DELAY	Adds modulation to the delayed sound.	Balance: Volume balance between the direct sound and the delay sound (D100:0W–D0:100W)

Indicated number	MFX Type	Overview	Effect parameter name when changed by holding down [MULTI EFFECTS] and pressing [INC] or [DEC] (p. 29): An overview thereof (Value)
47	3TAP PAN DELAY	Produces three delay sounds; center, left and right.	Balance: Volume balance between the direct sound and the delay sound (D100:0W-D0:100W)
48	4TAP PAN DELAY	This effect has four delays.	Balance: Volume balance between the direct sound and the delay sound (D100:0W-D0:100W)
49	MULTI TAP DELAY	This effect provides four delays with feedback.	Balance: Volume balance between the direct sound and the delay sound (D100:0W-D0:100W)
50	REVERSE DELAY	This is a reverse delay that adds a reversed and delayed sound to the input sound.	Balance: Volume balance between the direct sound and the delay sound (D100:0W-D0:100W)
51	SHUFFLE DELAY	Adds a shuffle to the delay sound, giving the sound a bouncy delay effect with a swing feel.	Balance: Volume balance between the direct sound and the delay sound (D100:0W-D0:100W)
52	3D DELAY	This applies a 3D effect to the delay sound. The delay sound will be positioned 90 degrees left and 90 degrees right.	Balance: Volume balance between the direct sound and the delay sound (D100:0W-D0:100W)
53	TIME CONTROL DELAY	A stereo delay in which the delay time can be varied smoothly.	Balance: Volume balance between the direct sound and the delay sound (D100:0W-D0:100W)
54	LONG TIME CONTROL DELAY	A delay in which the delay time can be varied smoothly, and allowing an extended delay to be produced.	Balance: Volume balance between the direct sound and the delay sound (D100:0W-D0:100W)
55	TAPE ECHO	A virtual tape echo that produces a realistic tape delay sound.	Echo Level: Volume of the echo sound (0-127)
56	LOFI NOISE	In addition to a Lo-Fi effect, this adds various types of noise such as white noise and disc noise.	Balance: Volume balance between the direct sound and the effect sound (D100:0W-D0:100W)
57	LOFI COMPRESSOR	This is an effect that intentionally degrades the sound quality for creative purposes.	Balance: Volume balance between the direct sound and the effect sound (D100:0W-D0:100W)
58	LOFI RADIO	In addition to a Lo-Fi effect, this effect also generates radio noise.	Balance: Volume balance between the direct sound and the effect sound (D100:0W-D0:100W)
59	TELEPHONE	This applies a telephone sound.	Balance: Volume balance between the direct sound and the effect sound (D100:0W-D0:100W)
60	PHONOGRAPH	Simulates a sound recorded on an analog record and played back on a record player.	Balance: Volume balance between the direct sound and the effect sound (D100:0W-D0:100W)
61	PITCH SHIFTER	A stereo pitch shifter.	Fine: Adjusts the pitch of the pitch shifted sound (-100cent+100cent)
62	2VOICE PITCH SHIFTER	Shifts the pitch of the original sound. This 2-voice pitch shifter has two pitch shifters, and can add two pitch shifted sounds to the original sound.	Balance: Volume balance between the Pitch Shift 1 and Pitch Shift 2 sounds (D100:0W-D0:100W)
63	STEP PITCH SHIFTER	This pitch shifter changes the shift volume of the pitch shift sound in a stepped fashion.	Rate: Rate of modulation (0.05-10.00 Hz)
64	REVERB	Adds reverberation to the sound, simulating an acoustic space.	Time: Time length of reverberation (0-127)
65	GATED REVERB	This is a special type of reverb in which the reverberant sound is cut off before its natural length.	Balance: Volume balance between the direct sound and the reverb sound (D100:0W-D0:100W)
66	OVERDRIVE →CHORUS	This effect connects an overdrive and a chorus in series.	Chorus Balance: Adjusts the volume balance between the sound that is sent through the chorus and the sound that is not sent through the chorus (D100:0W-D0:100W)
67	OVERDRIVE →FLANGER	This effect connects an overdrive and a flanger in series.	Flanger Balance: Adjusts the volume balance between the sound that is sent through the flanger and the sound that is not sent through the flanger (D100:0W-D0:100W)

Effect List

Indicated number	MFX Type	Overview	Effect parameter name when changed by holding down [MULTI EFFECTS] and pressing [INC] or [DEC] (p. 29): An overview thereof (Value)
68	OVERDRIVE →DELAY	This effect connects an overdrive and a delay in series.	Delay Balance: Adjusts the volume balance between the sound that is sent through the delay and the sound that is not sent through the delay (D100:0W-D0:100W)
69	DISTORTION →CHORUS	This effect connects a distortion and a chorus in series.	Chorus Balance: Adjusts the volume balance between the sound that is sent through the chorus and the sound that is not sent through the chorus (D100:0W-D0:100W)
70	DISTORTION →FLANGER	This effect connects a distortion and a flanger in series.	Flanger Balance: Adjusts the volume balance between the sound that is sent through the flanger and the sound that is not sent through the flanger (D100:0W-D0:100W)
71	DISTORTION →DELAY	This effect connects a distortion and a delay in series.	Delay Balance: Adjusts the volume balance between the sound that is sent through the delay and the sound that is not sent through the delay (D100:0W-D0:100W)
72	ENHANCER →CHORUS	This effect connects an enhancer and a chorus in series.	Chorus Balance: Adjusts the volume balance between the sound that is sent through the chorus and the sound that is not sent through the chorus (D100:0W-D0:100W)
73	ENHANCER →FLANGER	This effect connects an enhancer and a flanger in series.	Flanger Balance: Adjusts the volume balance between the sound that is sent through the flanger and the sound that is not sent through the flanger (D100:0W-D0:100W)
74	ENHANCER →DELAY	This effect connects an enhancer and a delay in series.	Delay Balance: Adjusts the volume balance between the sound that is sent through the delay and the sound that is not sent through the delay (D100:0W-D0:100W)
75	CHORUS →DELAY	This effect connects a chorus and a delay in series.	Delay Balance: Adjusts the volume balance between the sound that is sent through the delay and the sound that is not sent through the delay (D100:0W-D0:100W)
76	FLANGER →DELAY	This effect connects a flanger and a delay in series.	Delay Balance: Adjusts the volume balance between the sound that is sent through the delay and the sound that is not sent through the delay (D100:0W-D0:100W)
77	CHORUS →FLANGER	This effect connects a chorus and a flanger in series.	Flanger Balance: Adjusts the volume balance between the sound that is sent through the flanger and the sound that is not sent through the flanger (D100:0W-D0:100W)
78	SYMPATHETIC RESONANCE	On an acoustic piano, holding down the damper pedal allows other strings to resonate in sympathy with the notes you play, creating rich and spacious resonances. This effect simulates these sympathetic resonances.	Depth: Depth of the effect (0-127)

Tone List

MSB: Bank Select MSB (Control Number: 0)

LSB: Bank Select LSB (Control Number: 32)

PC: Program Change

PIANO

No.	Tone Name	MSB	LSB	PC
1	Superior Grd	87	64	1
2	Ultimate Pno	87	64	2
3	Grand RD	87	64	3
4	Pure Grand	87	64	4
5	Mellow Piano	87	64	5
6	Pure Mellow	87	64	6
7	Superior Str	87	64	7
8	Superior Pad	87	64	8
9	Rock Piano	87	64	9
10	Honky-tonk	87	64	10
11	SuperiorMono	87	64	11
12	GrandRD Mono	87	64	12

E. PIANO

No.	Tone Name	MSB	LSB	PC
1	StageE.Piano	87	65	1
2	Stage Phazer	87	65	2
3	60'sE.Piano1	87	65	3
4	60'sE.Piano2	87	65	4
5	FM E.Piano	87	65	5
6	70's E.Piano	87	65	6
7	EP Belle	87	65	7
8	D-50 E.Piano	87	65	8
9	Vintage EP 1	87	65	9
10	Vintage EP 2	87	65	10
11	S.A.E.P.	87	65	11
12	Funky D	87	65	12
13	Clav	87	65	13
14	Phase Clav	87	65	14
15	WahWah Clav	87	65	15
16	Natural Hps.	87	65	16
17	Celesta	87	65	17
18	Vibrations	87	65	18
19	Marimba	87	65	19
20	Morning Lite	87	65	20

ORGAN

No.	Tone Name	MSB	LSB	PC
1	Zepix Organ	87	66	1
2	Perc Organ	87	66	2
3	Rock Organ	87	66	3
4	Gospel Spin	87	66	4
5	Mellow Bars	87	66	5
6	FullDraw Org	87	66	6
7	60's Organ	87	66	7
8	Surf's Up!	87	66	8
9	Purple Spin	87	66	9
10	Massive Pipe	87	66	10
11	Mid Pipe Org	87	66	11
12	ParisRomance	87	66	12

STRINGS/PAD

No.	Tone Name	MSB	LSB	PC
1	Rich Strings	87	67	1
2	Studio Sect.	87	67	2
3	Staccato VS	87	67	3
4	Warm Strings	87	67	4
5	OrchestraPad	87	67	5
6	Orch & Horns	87	67	6
7	ChmbrStrings	87	67	7
8	Pizzicato	87	67	8
9	Machine Str	87	67	9
10	JP Strings	87	67	10
11	SynthStrings	87	67	11
12	Soft Pad	87	67	12
13	Silky Way	87	67	13
14	Nu Epic Pad	87	67	14
15	Strings Pad	87	67	15
16	Side Band X	87	67	16
17	Glass Organ	87	67	17
18	StellarTreck	87	67	18
19	Mash Pad	87	67	19
20	InfinitePhsr	87	67	20
21	Flange Dream	87	67	21

GUITAR/BASS

No.	Tone Name	MSB	LSB	PC
1	Dyna Nylon	87	68	1
2	Steel Gtr	87	68	2
3	Jz Gtr Hall	87	68	3
4	JC Strat	87	68	4
5	DistGt Mt	87	68	5
6	Blusey OD	87	68	6
7	Punker	87	68	7
8	AcousticBass	87	68	8
9	FingerMaster	87	68	9
10	Pick Bass	87	68	10
11	Slap Bass	87	68	11
12	SX Fretnot	87	68	12
13	Punch MG	87	68	13
14	Garage Bass	87	68	14
15	101 Bass	87	68	15
16	Synth Bass	87	68	16
17	Vox Bass	87	68	17
18	Bass+RideCym	87	68	18

BRASS/WINDS

No.	Tone Name	MSB	LSB	PC
1	R&R Brass	87	69	1
2	VoyagerBrass	87	69	2
3	StackTp Sect	87	69	3
4	FullSt Brass	87	69	4
5	Wood Symphny	87	69	5
6	Bigband Sax	87	69	6
7	Soprano Sax	87	69	7
8	Alto Sax	87	69	8
9	Tenor Sax	87	69	9
10	Flute	87	69	10
11	Bend SynBrs	87	69	11
12	Saw Brass	87	69	12
13	Jump For KY	87	69	13
14	Afro Horns	87	69	14

VOICE/SYNTH

No.	Tone Name	MSB	LSB	PC
1	Aerial Choir	87	70	1
2	Jazz Scat	87	70	2
3	Morning Star	87	70	3
4	Choir Aahs	87	70	4
5	Jazz Doos	87	70	5
6	Female Aahs	87	70	6
7	Gospel Oohs	87	70	7
8	Galactic SX	87	70	8
9	Synth Stack	87	70	9
10	Saw Lead	87	70	10
11	Square Lead	87	70	11
12	SuperSawSlow	87	70	12
13	Jupiter Lead	87	70	13

Tone List

RHY/GM2

No.	Tone Name	MSB	LSB	PC	No.	Tone Name	MSB	LSB	PC
1	RD Pop Kit	86	64	1	62	Reed Organ	121	0	21
2	RD Rock Kit	86	64	2	63	Puff Organ	121	1	21
3	RD Jazz Kit	86	64	3	64	Accordion Fr	121	0	22
4	RD R&B Kit	86	64	4	65	Accordion It	121	1	22
5	RD House Kit	86	64	5	66	Harmonica	121	0	23
6	GM2 STANDARD	120	0	1	67	Bandoneon	121	0	24
7	GM2 ROOM	120	0	9	68	Nylon-str.Gt	121	0	25
8	GM2 POWER	120	0	17	69	Ukulele	121	1	25
9	GM2 ELECTRIC	120	0	25	70	Nylon Gt.o	121	2	25
10	GM2 ANALOG	120	0	26	71	Nylon Gt.2	121	3	25
11	GM2 JAZZ	120	0	33	72	Steel-str.Gt	121	0	26
12	GM2 BRUSH	120	0	41	73	12-str.Gt	121	1	26
13	GM2 ORCHSTRA	120	0	49	74	Mandolin	121	2	26
14	GM2 SFX	120	0	57	75	Steel + Body	121	3	26
15	Piano 1	121	0	1	76	Jazz Gt.	121	0	27
16	Piano 1w	121	1	1	77	Pedal Steel	121	1	27
17	European Pf	121	2	1	78	Clean Gt.	121	0	28
18	Piano 2	121	0	2	79	Chorus Gt.	121	1	28
19	Piano 2w	121	1	2	80	Mid Tone GTR	121	2	28
20	Piano 3	121	0	3	81	Muted Gt.	121	0	29
21	Piano 3w	121	1	3	82	Funk Pop	121	1	29
22	Honky-tonk	121	0	4	83	Funk Gt.2	121	2	29
23	Honky-tonk 2	121	1	4	84	Jazz Man	121	3	29
24	E.Piano 1	121	0	5	85	Overdrive Gt	121	0	30
25	St.Soft EP	121	1	5	86	Guitar Pinch	121	1	30
26	FM+SA EP	121	2	5	87	DistortionGt	121	0	31
27	60's E.Piano	121	3	5	88	Feedback Gt.	121	1	31
28	E.Piano 2	121	0	6	89	Dist Rtm GTR	121	2	31
29	Detuned EP 2	121	1	6	90	Gt.Harmonics	121	0	32
30	St.FM EP	121	2	6	91	Gt. Feedback	121	1	32
31	EP Legend	121	3	6	92	Acoustic Bs.	121	0	33
32	EP Phase	121	4	6	93	Fingered Bs.	121	0	34
33	Harpsichord	121	0	7	94	Finger Slap	121	1	34
34	Coupled Hps.	121	1	7	95	Picked Bass	121	0	35
35	Harpsi.w	121	2	7	96	Fretless Bs.	121	0	36
36	Harpsi.o	121	3	7	97	Slap Bass 1	121	0	37
37	Clav.	121	0	8	98	Slap Bass 2	121	0	38
38	Pulse Clav	121	1	8	99	Synth Bass 1	121	0	39
39	Celesta	121	0	9	100	SynthBass101	121	1	39
40	Glockenspiel	121	0	10	101	Acid Bass	121	2	39
41	Music Box	121	0	11	102	Clavi Bass	121	3	39
42	Vibraphone	121	0	12	103	Hammer	121	4	39
43	Vibraphone w	121	1	12	104	Synth Bass 2	121	0	40
44	Marimba	121	0	13	105	Beef FM Bass	121	1	40
45	Marimba w	121	1	13	106	RubberBass 2	121	2	40
46	Xylophone	121	0	14	107	Attack Pulse	121	3	40
47	Tubular-bell	121	0	15	108	Violin	121	0	41
48	Church Bell	121	1	15	109	Slow Violin	121	1	41
49	Carillon	121	2	15	110	Viola	121	0	42
50	Santur	121	0	16	111	Cello	121	0	43
51	Organ 1	121	0	17	112	Contrabass	121	0	44
52	Trem. Organ	121	1	17	113	Tremolo Str	121	0	45
53	60's Organ 1	121	2	17	114	PizzicatoStr	121	0	46
54	70's E.Organ	121	3	17	115	Harp	121	0	47
55	Organ 2	121	0	18	116	Yang Qin	121	1	47
56	Chorus Or.2	121	1	18	117	Timpani	121	0	48
57	Perc. Organ	121	2	18	118	Orche str	121	0	49
58	Organ 3	121	0	19	119	Orchestra	121	1	49
59	Church Org.1	121	0	20	120	60s Strings	121	2	49
60	Church Org.2	121	1	20	121	Slow Strings	121	0	50
61	Church Org.3	121	2	20	122	Syn.Strings1	121	0	51
					123	Syn.Strings3	121	1	51
					124	Syn.Strings2	121	0	52
					125	Choir Aahs	121	0	53
					126	Chorus Aahs	121	1	53
					127	Voice Oohs	121	0	54
					128	Humming	121	1	54
					129	SynVox	121	0	55
					130	Analog Voice	121	1	55
					131	OrchestraHit	121	0	56
					132	Bass Hit	121	1	56
					133	6th Hit	121	2	56
					134	Euro Hit	121	3	56
					135	Trumpet	121	0	57
					136	Dark Trumpet	121	1	57
					137	Trombone	121	0	58
					138	Trombone 2	121	1	58
					139	Bright Tb	121	2	58
					140	Tuba	121	0	59
					141	MutedTrumpet	121	0	60
					142	MuteTrumpet2	121	1	60
					143	French Horns	121	0	61
					144	Fr.Horn 2	121	1	61
					145	Brass 1	121	0	62
					146	Brass 2	121	1	62
					147	Synth Brass1	121	0	63
					148	Pro Brass	121	1	63
					149	Oct SynBrass	121	2	63
					150	Jump Brass	121	3	63
					151	Synth Brass2	121	0	64
					152	SynBrass sfz	121	1	64
					153	Velo Brass 1	121	2	64
					154	Soprano Sax	121	0	65
					155	Alto Sax	121	0	66
					156	Tenor Sax	121	0	67
					157	Baritone Sax	121	0	68
					158	Oboe	121	0	69
					159	English Horn	121	0	70
					160	Bassoon	121	0	71
					161	Clarinet	121	0	72
					162	Piccolo	121	0	73
					163	Flute	121	0	74
					164	Recorder	121	0	75
					165	Pan Flute	121	0	76
					166	Bottle Blow	121	0	77
					167	Shakuhachi	121	0	78
					168	Whistle	121	0	79
					169	Ocarina	121	0	80
					170	Square Wave	121	0	81
					171	MG Square	121	1	81
					172	2600 Sine	121	2	81
					173	Saw Wave	121	0	82
					174	OB2 Saw	121	1	82
					175	Doctor Solo	121	2	82
					176	Natural Lead	121	3	82
					177	SequencedSaw	121	4	82
					178	Syn.Calliope	121	0	83
					179	Chiffer Lead	121	0	84
					180	Charang	121	0	85
					181	Wire Lead	121	1	85
					182	Solo Vox	121	0	86
					183	5th Saw Wave	121	0	87
					184	Bass & Lead	121	0	88
					185	Delayed Lead	121	1	88
					186	Fantasia	121	0	89
					187	Warm Pad	121	0	90
					188	Sine Pad	121	1	90
					189	Polysynth	121	0	91

No.	Tone Name	MSB	LSB	PC	No.	Tone Name	MSB	LSB	PC
190	Space Voice	121	0	92	254	Car-Pass	121	3	126
191	Itopia	121	1	92	255	Car-Crash	121	4	126
192	Bowed Glass	121	0	93	256	Siren	121	5	126
193	Metal Pad	121	0	94	257	Train	121	6	126
194	Halo Pad	121	0	95	258	Jetplane	121	7	126
195	Sweep Pad	121	0	96	259	Starship	121	8	126
196	Ice Rain	121	0	97	260	Burst Noise	121	9	126
197	Soundtrack	121	0	98	261	Applause	121	0	127
198	Crystal	121	0	99	262	Laughing	121	1	127
199	Syn Mallet	121	1	99	263	Screaming	121	2	127
200	Atmosphere	121	0	100	264	Punch	121	3	127
201	Brightness	121	0	101	265	Heart Beat	121	4	127
202	Goblin	121	0	102	266	Footsteps	121	5	127
203	Echo Drops	121	0	103	267	Gun Shot	121	0	128
204	Echo Bell	121	1	103	268	Machine Gun	121	1	128
205	Echo Pan	121	2	103	269	Lasergun	121	2	128
206	Star Theme	121	0	104	270	Explosion	121	3	128
207	Sitar	121	0	105					
208	Sitar 2	121	1	105					
209	Banjo	121	0	106					
210	Shamisen	121	0	107					
211	Koto	121	0	108					
212	Taisho Koto	121	1	108					
213	Kalimba	121	0	109					
214	Bagpipe	121	0	110					
215	Fiddle	121	0	111					
216	Shanai	121	0	112					
217	Tinkle Bell	121	0	113					
218	Agogo	121	0	114					
219	Steel Drums	121	0	115					
220	Woodblock	121	0	116					
221	Castanets	121	1	116					
222	Taiko	121	0	117					
223	Concert BD	121	1	117					
224	Melo. Tom 1	121	0	118					
225	Melo. Tom 2	121	1	118					
226	Synth Drum	121	0	119					
227	808 Tom	121	1	119					
228	Elec Perc	121	2	119					
229	Reverse Cym.	121	0	120					
230	Gt.FretNoise	121	0	121					
231	Gt.Cut Noise	121	1	121					
232	String Slap	121	2	121					
233	Breath Noise	121	0	122					
234	Fl.Key Click	121	1	122					
235	Seashore	121	0	123					
236	Rain	121	1	123					
237	Thunder	121	2	123					
238	Wind	121	3	123					
239	Stream	121	4	123					
240	Bubble	121	5	123					
241	Bird	121	0	124					
242	Dog	121	1	124					
243	Horse-Gallop	121	2	124					
244	Bird 2	121	3	124					
245	Telephone 1	121	0	125					
246	Telephone 2	121	1	125					
247	DoorCreaking	121	2	125					
248	Door	121	3	125					
249	Scratch	121	4	125					
250	Wind Chimes	121	5	125					
251	Helicopter	121	0	126					
252	Car-Engine	121	1	126					
253	Car-Stop	121	2	126					

Rhythm Set List

* [EXC]: will not sound simultaneously with other percussion instruments of the same number.

	RD Pop Kit	RD Rock Kit	RD Jazz Kit	RD R&B Kit	RD House Kit
21	Rock Kick	Old Kick	Old Kick	Analog Kick 2	Dance Kick
22	Pop Kick	Pop Kick	Jazz Kick 1	TR909 Kick 1	Lo-Bit CHH [EXC1]
23	Analog Kick 1	Analog Kick 1	Analog Kick 1	TR909 Kick 2	Techno Kick 2
24	Hush Kick	Rock Kick	Jazz Swish	R&B CHH 2 [EXC1]	Concert Snare
25	Pop CHH 1 [EXC1]	Rock CHH1 [EXC1]	Jazz Tap 1	R&B CHH 3 [EXC1]	Snare Roll
26	Reg. Snare 1	Rock Snare 1	Jazz Tap 2	R&B CHH 4 [EXC1]	Finger Snap
27	Finger Snap	Finger Snap	Finger Snap	Finger Snap	High-Q
28	707 Claps	707 Claps	707 Claps	707 Claps	Slap
29	Hand Clap 1	Hand Clap 1	Hand Clap 1	Hand Clap 1	Scratch Push
30	Hand Clap 2	Hand Clap 2	Hand Clap 2	Gospel Hand Clap 2	Scratch Pull
31	Hand Clap 3	Hand Clap 3	Hand Clap 3	Hand Clap 2	Sticks
32	Pop PHH [EXC1]	Pop PHH [EXC1]	Pop PHH [EXC1]	R&B CHH 5 [EXC1]	Square Click
33	Hand Clap 4	Hand Clap 4	Gospel Hand Clap	Gospel Hand Clap	Metro Click
34	Snare Roll	Snare Roll	Snare Roll	Lo-Bit CHH [EXC1]	Metro Bell
35	Old Kick	Old Kick	Pop Kick	Analog Kick 1	House Kick 1
C2 36	Hush Kick	Rock Kick	Jazz Kick 2	R&B Kick	House Kick 2
37	Reg.Stick	Rock Side Stick	Jazz Snare Swing	R&B Side Stick 1	R&B Side Stick 1
38	Reg. Snare	Rock Snare 1	Jazz Snare 1	R&B Snare 1	House Snare 1
39	Reg. Snare Ghost	Snare Ghost	Pop Snare Swing	R&B Snare 2	House Snare 2
40	Titan Snare	Rock Snare 2	Jazz Snare 2	R&B Snare 3	House Snare 3
41	Reg. Low Tom Flm	Rock Low Tom Flm	Jazz Low Tom Flm	Sharp Low Tom 6	House Low Tom 1
42	Pop CHH 1 [EXC1]	Rock CHH 1 [EXC1]	Pop CHH 1 [EXC1]	R&B CHH 1 [EXC1]	House CHH [EXC1]
43	Reg. Low Tom	Rock Low Tom	Jazz Low Tom	Sharp Low Tom 5	House Low Tom 2
44	Pop CHH 2 [EXC1]	Rock CHH 2 [EXC1]	Pop CHH 2 [EXC1]	R&B CHH 1 [EXC1]	House PHH [EXC1]
45	Reg.Mid Tom Flm	Rock Mid Tom Flm	Jazz Mid Tom Flm	Sharp Low Tom 4	House Mid Tom 1
46	Pop OHH [EXC1]	Rock OHH [EXC1]	Pop OHH [EXC1]	R&B OHH [EXC1]	House OHH [EXC1]
47	Reg. Mid Tom	Rock Mid Tom	Jazz Mid Tom	Sharp High Tom 3	House Mid Tom 2
C3 48	Reg. High Tom Flm	Rock High Tom Flm	Jazz High Tom Flm	Sharp High Tom 2	House High Tom 1
49	Pop Crash Cymbal 1	Rock Crash Cymbal	Jazz Crash Cymbal	R&B Crash Cymbal	House Crash Cymbal
50	Reg. High Tom	Rock HighTom	Jazz HighTom	Sharp High Tom 1	House High Tom 2
51	Pop RideCymbal 1	Rock RideCymbal 2	Jazz Ride Cymbal 1	Pop Ride Cymbal 1	House Ride Cymbal
52	Pop Chinese Cymbal	Rock Chinese Cymbal	Jazz Chinese Cymbal	R&B Chinese Cym	Reverse Cymbal
53	Pop Ride Bell	Rock Ride Bell	Jazz Ride Cymbal 2	R&B Ride Bell	House Ride Bell
54	Tambourine	Tambourine	Tambourine	ShakeTambourine	ShakeTambourine
55	Pop Splash Cymbal	Rock Splsh Cymbal	Pop Splsh Cymbal	TR909 Ride	House Splash Cymbal
56	Cha Cha Cowbell	Cha Cha Cowbell	Cha Cha Cowbell	Cha Cha Cowbell	House Cowbell
57	Pop Crash Cymbal 2	Rock Chinese Cymbal 2	Jazz Crash Cymbal 2	House Crash Cymbal	HouseCrash Cymbal
58	Vibraslap	Vibraslap	Vibraslap	Vibraslap	Vibraslap
59	Pop RideCymbal 2	Pop Ride Cymbal 1	Pop Ride Cymbal 1	Pop Ride Cymbal 2	Pop Ride Cymbal 2
C4 60	Bongo Hi	Bongo Hi	Bongo Hi	House Bongo Hi	House Bongo Hi
61	Bongo Lo	Bongo Lo	Bongo Lo	House Bongo Lo	House Bongo Lo
62	Conga Mute	Conga Mute	Conga Mute	House Conga Hi	House Conga Hi
63	Conga Hi	Conga Hi	Conga Hi	House Conga Mt	House Conga Mt
64	Conga Lo	Conga Lo	Conga Lo	House Conga Lo	House Conga Lo
65	Timbale Hi	Timbale Hi	Timbale Hi	Timbale Hi	Timbale Hi
66	Timbale Lo	Timbale Lo	Timbale Lo	Timbale Lo	Timbale Lo
67	Agogo Bell Hi	Agogo Bell Hi	Agogo Bell Hi	Agogo Bell Hi	Agogo Bell Hi
68	Agogo Bell Lo	Agogo Bell Lo	Agogo Bell Lo	Agogo Bell Lo	Agogo Bell Lo
69	Shaker 2	Shaker 2	Shaker 2	Cabasa	Cabasa
70	Shaker 3	Shaker 3	Shaker 3	House Maracas	House Maracas
71	Whistle Short [EXC2]	Whistle Short [EXC2]	Whistle Short [EXC2]	Whistle Short [EXC2]	Whistle Short [EXC2]
C5 72	Whistle Long [EXC2]	Whistle Long [EXC2]	Whistle Long [EXC2]	Whistle Long [EXC2]	Whistle Long [EXC2]
73	Guiro Short [EXC3]	Guiro Short [EXC3]	Guiro Short [EXC3]	Guiro Short [EXC3]	Guiro Short [EXC3]
74	Guiro Long [EXC3]	Guiro Long [EXC3]	Guiro Long [EXC3]	Guiro Long [EXC3]	Guiro Long [EXC3]
75	Claves	Claves	Claves	House Claves	House Claves
76	Wood Block Hi	Wood Block Hi	Wood Block Hi	Wood Block Hi	Wood Block Hi
77	Wood Block Lo	Wood Block Lo	Wood Block Lo	Wood Block Lo	Wood Block Lo
78	Cuica Mute [EXC4]	Cuica Mute [EXC4]	Cuica Mute [EXC4]	Hoo Hi [EXC4]	Hoo Hi [EXC4]
79	Cuica Open [EXC4]	Cuica Open [EXC4]	Cuica Open [EXC4]	Hoo Lo [EXC4]	Hoo Lo [EXC4]
80	Triangle Mt [EXC5]	Triangle Mt [EXC5]	Triangle Mt [EXC5]	Triangle Mt [EXC5]	Electric Triangle Mt [EXC5]
81	Triangle Op [EXC5]	Triangle Op [EXC5]	Triangle Op [EXC5]	Triangle Op [EXC5]	Electric Triangle Op [EXC5]
82	Cabasa	Cabasa	Cabasa	Shaker	Shaker
83	Jingle Bell	Jingle Bell	Jingle Bell	Jingle Bell	Jingle Bell
C6 84	Wind Chime	Wind Chime	Wind Chime	Wind Chime	Wind Chime
85	Castanets	Castanets	Castanets	Castanets	Castanets
86	Surdo Mute [EXC6]	Surdo Mute [EXC6]	Surdo Mute [EXC6]	Surdo Mute [EXC6]	Surdo Mute [EXC6]
87	Surdo Open [EXC6]	Surdo Open [EXC6]	Surdo Open [EXC6]	Surdo Open [EXC6]	Surdo Open [EXC6]
88	Cana	Cana	Cana	Tambourine	Cana
89	Flamenco Timbale Hi	Flamenco Timbale Hi	Flamenco Timbale Hi	Tambourine	Flamenco Timbale Hi
90	Flamenco Timbale Lo	Flamenco Timbale Lo	Flamenco Timbale Lo	Cabasa Up	Flamenco Timbale Lo
91	Flamenco Timbale Flam	Flamenco Timbale Flam	Flamenco Timbale Flam	Cabasa Down	Flamenco Timbale Flam
92	Shaker 1	Shaker 1	Shaker 1	Shaker 1	Shaker 1
93	Shaker 2	Shaker 2	Shaker 2	Shaker 2	Shaker 2
94	Bongo Lo Mt	Bongo Lo Mt	Bongo Lo Mt	Bongo Lo Mt	Bongo Lo Mt
95	Grit Snare	LoFi Snare	Jazz Snare 1	Grit Snare	LoFi Snare
C7 96	Jungle Snare 1	Jungle Snare 1	Jazz Snare 2	Jungle Snare 1	Jungle Snare 1
97	Reg.Stick	Rock Side Stick	Jazz Snare Swing	R&B Side Stick 2	R&B Side Stick 2
98	Titan Snare	Rock Snare 2	Jazz Swish	Analog Snare	Analog Snare
99	Old Kick	Old Kick	Old Kick	HipHop Kick	TR808 Kick 1
100	Pop Kick	Pop Kick	Jazz Kick 1	TR808 Kick 1	TR808 Kick 2
101	Rock Kick	Rock Kick	Jazz Kick 2	TR808 Kick 2	Jungle Kick
102	Analog Kick 1	Analog Kick 1	Analog Kick 1	Techno Kick	Techno Kick
103	Rock Snare Dry	Rock Snare Dry	Jazz Tap 1	Rock Snare Dry	Rock Snare Dry
104	Electric Snare	Electric Snare	Jazz Tap 2	Electric Snare	Electric Snare
105	Reg. Snare Ghost	Rock Snare Ghost	Pop Snare Swing	Jungle Snare 2	Jungle Snare 2
106	Slappy	Slappy	Slappy	Vinyl Noise	Slappy
107	Wah Gtr Noise 1	Wah Gtr Noise 1	Wah Gtr Noise 1	Wah Gtr Noise 1	Wah Gtr Noise 1
C8 108	Wah Gtr Noise 2	Wah Gtr Noise 2	Wah Gtr Noise 2	Wah Gtr Noise 2	Wah Gtr Noise 2

* - - - -: No sound.

* [EXC]: will not sound simultaneously with other percussion instruments of the same number.

	GM2 STANDARD	GM2 ROOM	GM2 POWER	GM2 ELECTRIC
21	----	----	----	----
22	----	----	----	----
23	----	----	----	----
24	----	----	----	----
25	----	----	----	----
26	----	----	----	----
27	High-Q	High-Q	High-Q	High-Q
28	Slap	Slap	Slap	Slap
29	ScratchPush [EXC7]	ScratchPush [EXC7]	ScratchPush [EXC7]	ScratchPush [EXC7]
30	ScratchPull [EXC7]	ScratchPull [EXC7]	ScratchPull [EXC7]	ScratchPull [EXC7]
31	Sticks	Sticks	Sticks	Sticks
32	SquareClick	SquareClick	SquareClick	SquareClick
33	Mtrnm.Click	Mtrnm.Click	Mtrnm.Click	Mtrnm.Click
34	Mtrnm. Bell	Mtrnm. Bell	Mtrnm. Bell	Mtrnm. Bell
35	Jazz Kick 1	Mix Kick	Standard KK1	Power Kick1
C2 36	Mix Kick	Standard KK1	Power Kick1	Elec Kick 1
37	Side Stick	Side Stick	Side Stick	Side Stick
38	Standard SN1	Standard SN2	Dance Snare1	Elec. Snare
39	909 HandClap	909 HandClap	909 HandClap	909 HandClap
40	Elec Snare 3	Elec Snare 7	Elec Snare 4	Elec Snare 2
41	Real Tom 6	Room Tom 5	Room Tom 5	Synth Drum 2
42	Close HiHat2 [EXC1]	Close HiHat2 [EXC1]	Close HiHat2 [EXC1]	Close HiHat2 [EXC1]
43	Real Tom 6	Room Tom 6	Room Tom 6	Synth Drum 2
44	Pedal HiHat2 [EXC1]	Pedal HiHat2 [EXC1]	Pedal HiHat2 [EXC1]	Pedal HiHat2 [EXC1]
45	Real Tom 4	Room Tom 2	Room Tom 2	Synth Drum 2
46	Open HiHat2 [EXC1]	Open HiHat2 [EXC1]	Open HiHat2 [EXC1]	Open HiHat2 [EXC1]
47	Real Tom 4	Room Tom 2	Room Tom 2	Synth Drum 2
C3 48	Real Tom 1	Rock Tom 1	Rock Tom 1	Synth Drum 2
49	Crash Cym.1	Crash Cym.1	Crash Cym.1	Crash Cym.1
50	Real Tom 1	Rock Tom 1	Rock Tom 1	Synth Drum 2
51	Ride Cymbal	Ride Cymbal	Ride Cymbal	Ride Cymbal
52	ChinaCymbal	ChinaCymbal	ChinaCymbal	ReverseCymbal
53	Ride Bell	Ride Bell	Ride Bell	Ride Bell
54	Tambourine	Tambourine	Tambourine	Tambourine
55	Splash Cym.	Splash Cym.	Splash Cym.	Splash Cym.
56	Cowbell	Cowbell	Cowbell	Cowbell
57	Crash Cym.2	Crash Cym.2	Crash Cym.2	Crash Cym.2
58	Vibraslap	Vibraslap	Vibraslap	Vibraslap
59	Ride Cymbal4	Ride Cymbal4	Ride Cymbal4	Ride Cymbal4
C4 60	Bongo High	Bongo High	Bongo High	Bongo High
61	Bongo Lo	Bongo Lo	Bongo Lo	Bongo Lo
62	Mute H.Conga	Mute H.Conga	Mute H.Conga	Mute H.Conga
63	Conga Hi Opn	Conga Hi Opn	Conga Hi Opn	Conga Hi Opn
64	Conga Lo Opn	Conga Lo Opn	Conga Lo Opn	Conga Lo Opn
65	High Timbale	High Timbale	High Timbale	High Timbale
66	Low Timbale	Low Timbale	Low Timbale	Low Timbale
67	Agogo	Agogo	Agogo	Agogo
68	Agogo	Agogo	Agogo	Agogo
69	Cabasa	Cabasa	Cabasa	Cabasa
70	Maracas	Maracas	Maracas	Maracas
71	ShrtWhistle [EXC2]	ShrtWhistle [EXC2]	ShrtWhistle [EXC2]	ShrtWhistle [EXC2]
C5 72	LongWhistle [EXC2]	LongWhistle [EXC2]	LongWhistle [EXC2]	LongWhistle [EXC2]
73	Short Guiro [EXC3]	Short Guiro [EXC3]	Short Guiro [EXC3]	Short Guiro [EXC3]
74	Long Guiro [EXC3]	Long Guiro [EXC3]	Long Guiro [EXC3]	Long Guiro [EXC3]
75	Claves	Claves	Claves	Claves
76	Woodblock	Woodblock	Woodblock	Woodblock
77	Woodblock	Woodblock	Woodblock	Woodblock
78	Mute Cuica [EXC4]	Mute Cuica [EXC4]	Mute Cuica [EXC4]	Mute Cuica [EXC4]
79	Open Cuica [EXC4]	Open Cuica [EXC4]	Open Cuica [EXC4]	Open Cuica [EXC4]
80	MuteTriangl [EXC5]	MuteTriangl [EXC5]	MuteTriangl [EXC5]	MuteTriangl [EXC5]
81	OpenTriangl [EXC5]	OpenTriangl [EXC5]	OpenTriangl [EXC5]	OpenTriangl [EXC5]
82	Shaker	Shaker	Shaker	Shaker
83	Jingle Bell	Jingle Bell	Jingle Bell	Jingle Bell
C6 84	Bell Tree	Bell Tree	Bell Tree	Bell Tree
85	Castanets	Castanets	Castanets	Castanets
86	Mute Surdo [EXC6]	Mute Surdo [EXC6]	Mute Surdo [EXC6]	Mute Surdo [EXC6]
87	Open Surdo [EXC6]	Open Surdo [EXC6]	Open Surdo [EXC6]	Open Surdo [EXC6]
88	----	----	----	----

Rhythm Set List

* - - - - : No sound.

* [EXC]: will not sound simultaneously with other percussion instruments of the same number.

	GM2 ANALOG	GM2 JAZZ	GM2 BRUSH	GM2 ORCHSTRA	GM2 SFX
21	----	----	----	----	----
22	----	----	----	----	----
23	----	----	----	----	----
24	----	----	----	----	----
25	----	----	----	----	----
26	----	----	----	----	----
27	High-Q	High-Q	High-Q	Close HiHat2 [EXC1]	----
28	Slap	Slap	Slap	Pedal HiHat2 [EXC1]	----
29	ScratchPush [EXC7]	ScratchPush [EXC7]	ScratchPush [EXC7]	Open HiHat2 [EXC1]	----
30	ScratchPull [EXC7]	ScratchPull [EXC7]	ScratchPull [EXC7]	Ride Cymbal3	----
31	Sticks	Sticks	Sticks	Sticks	----
32	SquareClick	SquareClick	SquareClick	SquareClick	----
33	Mtrnm.Click	Mtrnm.Click	Mtrnm.Click	Mtrnm.Click	----
34	Mtrnm. Bell	Mtrnm. Bell	Mtrnm. Bell	Mtrnm. Bell	----
35	TR-808 Kick2	Jazz Kick 2	Jazz Kick 2	Concert BD	----
C2 36	TR-808 Kick	Jazz Kick 1	Jazz Kick 1	Mix Kick	----
37	808 Rimshot	Side Stick	Side Stick	Side Stick	----
38	808 Snare 1	Standard SN3	Brush Swirl	Concert Snr	----
39	909 HandClap	909 HandClap	Brush Slap1	Castanets	High-Q
40	Elec Snare 6	Elec Snare 5	Brush Swirl	Concert Snr	Slap
41	808 Tom 2	Real Tom 6	Brash Tom 2	Timpani	ScratchPush [EXC7]
42	TR-808 CHH [EXC1]	Close HiHat2 [EXC1]	Close HiHat3 [EXC1]	Timpani	ScratchPull [EXC7]
43	808 Tom 2	Real Tom 6	Brash Tom 2	Timpani	Sticks
44	808_chh [EXC1]	Pedal HiHat2 [EXC1]	Pedal HiHat3 [EXC1]	Timpani	SquareClick
45	808 Tom 2	Real Tom 4	Brash Tom 2	Timpani	Mtrnm.Click
46	TR-808 OHH [EXC1]	Open HiHat2 [EXC1]	Open HiHat3 [EXC1]	Timpani	Mtrnm. Bell
47	808 Tom 2	Real Tom 4	Brash Tom 2	Timpani	Gt.FretNoiz
C3 48	808 Tom 2	Real Tom 1	Brash Tom 2	Timpani	Gt.CutNoise
49	808 Crash	Crash Cym.1	Crash Cym.3	Timpani	Gt.CutNoise
50	808 Tom 2	Real Tom 1	Brash Tom 2	Timpani	String Slap
51	Ride Cymbal	Ride Cymbal	Ride Cymbal2	Timpani	Fl.KeyClick
52	ChinaCymbal	ChinaCymbal	ChinaCymbal	Timpani	Laughing
53	Ride Bell	Ride Bell 3	Ride Bell 2	Timpani	Screaming
54	Tambourine	Tambourine	Tambourine	Tambourine	Punch
55	Splash Cym.	Splash Cym.	Splash Cym.	Splash Cym.	Heart Beat
56	808cowbe	Cowbell	Cowbell	Cowbell	Footsteps
57	Crash Cym.2	Crash Cym.2	Crash Cym.2	Con.Cymbal2	Footsteps
58	Vibraslap	Vibraslap	Vibraslap	Vibraslap	Applause
59	Ride Cymbal4	Ride Cymbal4	Ride Cymbal4	Concert Cym.	Creaking
C4 60	Bongo High	Bongo High	Bongo High	Bongo High	Door
61	Bongo Lo	Bongo Lo	Bongo Lo	Bongo Lo	Scratch
62	808 Conga	Mute H.Conga	Mute H.Conga	Mute H.Conga	Wind Chimes
63	808 Conga	Conga Hi Opn	Conga Hi Opn	Conga Hi Opn	Car-Engine
64	808 Conga	Conga Lo Opn	Conga Lo Opn	Conga Lo Opn	Car-Stop
65	High Timbale	High Timbale	High Timbale	High Timbale	Car-Pass
66	Low Timbale	Low Timbale	Low Timbale	Low Timbale	Car-Crash
67	Agogo	Agogo	Agogo	Agogo	Siren
68	Agogo	Agogo	Agogo	Agogo	Train
69	Cabasa	Cabasa	Cabasa	Cabasa	Jetplane
70	808marac	Maracas	Maracas	Maracas	Helicopter
71	ShrtWhistle [EXC2]	ShrtWhistle [EXC2]	ShrtWhistle [EXC2]	ShrtWhistle [EXC2]	Starship
C5 72	LongWhistle [EXC2]	LongWhistle [EXC2]	LongWhistle [EXC2]	LongWhistle [EXC2]	Gun Shot
73	Short Guiro [EXC3]	Short Guiro [EXC3]	Short Guiro [EXC3]	Short Guiro [EXC3]	Machine Gun
74	Long Guiro [EXC3]	Long Guiro [EXC3]	Long Guiro [EXC3]	Long Guiro [EXC3]	Lasergun
75	808clave	Claves	Claves	Claves	Explosion
76	Woodblock	Woodblock	Woodblock	Woodblock	Dog
77	Woodblock	Woodblock	Woodblock	Woodblock	HorseGallop
78	Mute Cuica [EXC4]	Mute Cuica [EXC4]	Mute Cuica [EXC4]	Mute Cuica [EXC4]	Bird
79	Open Cuica [EXC4]	Open Cuica [EXC4]	Open Cuica [EXC4]	Open Cuica [EXC4]	Rain
80	MuteTriangl [EXC5]	MuteTriangl [EXC5]	MuteTriangl [EXC5]	MuteTriangl [EXC5]	Thunder
81	OpenTriangl [EXC5]	OpenTriangl [EXC5]	OpenTriangl [EXC5]	OpenTriangl [EXC5]	Wind
82	Shaker	Shaker	Shaker	Shaker	Seashore
83	Jingle Bell	Jingle Bell	Jingle Bell	Jingle Bell	Stream
C6 84	Bell Tree	Bell Tree	Bell Tree	Bell Tree	Bubble
85	Castanets	Castanets	Castanets	Castanets	----
86	Mute Surdo [EXC6]	Mute Surdo [EXC6]	Mute Surdo [EXC6]	Mute Surdo [EXC6]	----
87	Open Surdo [EXC6]	Open Surdo [EXC6]	Open Surdo [EXC6]	Open Surdo [EXC6]	----
88	----	----	----	Applause	----

Rhythm Pattern List

No.	Rhythm Pattern	No.	Rhythm Pattern	No.	Rhythm Pattern
001	Piano R&B 1	068	R&B 4	135	BossaNova 2
002	Piano R&B 2	069	R&B 5	136	BossaNova 3
003	8-Beat Funk	070	R&B 6	137	Fast Bossa
004	16-BeatFunk	071	R&B 7	138	Pop Bossa
005	8-BitShuffle	072	R&B 8	139	Salsa 1
006	16BitShuffle	073	R&B 9	140	Salsa 2
007	Latin Dance	074	R&B 10	141	Samba 1
008	LatinFusion	075	R&B 11	142	Samba 2
009	Fast Jazz	076	R&B 12	143	Rumba
010	Afro-Cuban	077	R&B 13	144	Mambo 1
011	Pop Ballad	078	R&B 14	145	Mambo 2
012	Ballad 1	079	R&B 15	146	Merengue
013	StraightRck	080	R&B 16	147	PwrFusion 1
014	PowerfulRck	081	R&B 17	148	PwrFusion 2
015	Slow Beat	082	R&B 18	149	Rock 1
016	Back Beat 1	083	Funk 1	150	Rock 2
017	Hip'n'Hop	084	Funk 2	151	Rock 3
018	ElecDance 1	085	Funk 3	152	Rock 4
019	Pop 1	086	8-BeatRock 1	153	Rock 5
020	Pop 2	087	8-BeatRock 2	154	Rock 6
021	Pop 3	088	8-BeatRock 3	155	Rock 7
022	Pop 4	089	16BeatRock 1	156	Rock 8
023	8-Beat Pop 1	090	16BeatRock 2	157	Rock 9
024	8-Beat Pop 2	091	Ballad 2	158	Rock 10
025	8-Beat Pop 3	092	Ballad 3	159	Rock 11
026	8-BitFusion 1	093	PianoBallad	160	Rock 12
027	8-BitFusion 2	094	Rockaballad	161	Rock 13
028	Pop Funk 1	095	Bluegrass	162	Rock 14
029	Pop Funk 2	096	Combo 1	163	Rock 15
030	Pop Funk 3	097	Combo 2	164	Rock 16
031	Pop Funk 4	098	FastSwing 1	165	Rock 17
032	Pop Funk 5	099	FastSwing 2	166	Rock 18
033	Pop Funk 6	100	Swing 1	167	Rock 19
034	Pop Funk 7	101	Swing 2	168	Rock 20
035	Pop Funk 8	102	Swing 3	169	Progressive
036	16-BeatPop 1	103	JazzBrush 1	170	ElecDance 2
037	16-BeatPop 2	104	JazzBrush 2	171	ElecDance 3
038	16-BeatPop 3	105	Jazz Waltz	172	ElecDance 4
039	16BitFusion 1	106	Free Jazz	173	ElecDance 5
040	16BitFusion 2	107	Jazz 1	174	ElecDance 6
041	16BitFusion 3	108	Jazz 2	175	ElecDance 7
042	ShufflePop 1	109	Jazz 3	176	ElecDance 8
043	ShufflePop 2	110	Jazz 4	177	ElecDance 9
044	ShufflePop 3	111	Jazz 5	178	ElecDance 10
045	ShufflePop 4	112	Jazz 6	179	Acid Jazz
046	ShufflePop 5	113	Jazz 7	180	Techno
047	ShufflePop 6	114	Jazz 8	181	Hip Hop
048	ShufflePop 7	115	Jazz 9	182	House
049	West Coast	116	Jazz 10	183	Jungle
050	Motown	117	Blues 1	184	Dance
051	R&B Pop 1	118	Blues 2	185	Pop Waltz 1
052	R&B Pop 2	119	Gospel 1	186	Pop Waltz 2
053	R&B Pop 3	120	Gospel 2	187	Pop Waltz 3
054	R&B Pop 4	121	Polka 1	188	Pop Waltz 4
055	R&B Pop 5	122	Polka 2	189	SimpleWltz 1
056	Back Beat 2	123	Latin Pop 1	190	SimpleWltz 2
057	Back Beat 3	124	Latin Pop 2	191	3/4 Brush
058	Back Beat 4	125	Latin Pop 3	192	5/4 Fusion
059	Back Beat 5	126	Latin Pop 4	193	5/4 Swing
060	Back Beat 6	127	Latin Pop 5	194	5/8 Progres
061	Back Beat 7	128	Latin Pop 6	195	6/4 Fusion
062	Back Beat 8	129	Latin Pop 7	196	6/8 Progres
063	Back Beat 9	130	Latin Pop 8	197	6/8 Swing
064	Back Beat 10	131	Latin Pop 9	198	7/4 Fusion
065	R&B 1	132	Latin Pop 10	199	7/4 Swing
066	R&B 2	133	Latin Pop 11	200	7/8 Progres
067	R&B 3	134	BossaNova 1		

Setup List

→ **Selecting Stored Settings ([SETUP] Button)** (p. 50)

“R.”: These Setups let you enjoy performing with a session-like feel while playing a Rhythm.
Be sure to check it out. For more on Rhythms, refer to the “Playing Rhythm ([SONG/RHYTHM] Button)” (p. 37).

[Piano]

01 Piano&Choir
02 Piano&Winds
03 R.Piano Pop
04 R.Jazz Trio

[STRINGS/PAD]

13 Strings Sect
14 Mysterious
15 R.Str Ballad
16 R.DancingPad

[VOICE/SYNTH]

25 Large Choir
26 Dance Groove
27 R.A Cappella
28 R.Synth Jam

[E. PIANO]

05 E.Piano&Pad
06 EP&Strings
07 R.EP R&B
08 R.ClavGroove

[GUITAR/BASS]

17 OD Guitar
18 Fretless&Pad
19 R.Cool Bossa
20 R.Bass Solo

[RHY/GM2]

29 RD SETUP
30 RD SETUP
31 RD SETUP
32 RD SETUP

[ORGAN]

09 OD Organ
10 Manual Bass
11 R.Hot Gospel
12 R.Jazz Funk

[BRASS/WINDS]

21 Full Brass
22 Sax Section
23 R.Brass Funk
24 R.Sax Ballad

* Setup No. 29–32 (RD SETUP)
include the “Basic Setup.” Use this
when creating Setups from scratch.

Shortcut List

You can easily change settings for the following functions using a number of related buttons.

* “[A] + [B]” indicates that you are to hold down [A] and press [B].

What to do	Operation	Page
Changing the Sound Control Type	[SOUND CONTROL] + [DEC] [INC]	p. 35
Changing the Reverb Depth	[REVERB] + [DEC] [INC]	p. 34
Changing the Reverb Depth for Each Tone	[REVERB] + ZONE LEVEL Slider	p. 34
Changing the Amount of Multi-effects Applied	[MULTI EFFECTS] + [DEC] [INC]	p. 47
Changing the Amount of Transposition	[TRANPOSE] + [DEC] [INC] [TRANPOSE] + Key	p. 32
Changing the Rhythm Pattern Volume Level	[SONG/RHYTHM] + ZONE LEVEL Slider *Can be operated while Rhythm is playing	p. 37
Changing Volume of Song (Audio File)	[SONG/RHYTHM] + ZONE LEVEL Slider *Can be operated while an audio file is playing	p. 40
Changing Volume of Audio Key (Audio File)	[AUDIO KEY] + ZONE LEVEL Slider	p. 42
Changing the Split Point Key	[SPLIT] + [DEC] [INC] [SPLIT] + Key	p. 29
Switching V-LINK On and Off	[EXIT/SHIFT] + [SOUND CONTROL]	p. 82
Changing the Reverb Type	[EXIT/SHIFT] + [REVERB]	p. 33
Changing the Multi-effects Type	[EXIT/SHIFT] + [MULTI EFFECTS]	p. 48
Adjusting the Frequency of the Equalizer	[EXIT/SHIFT] + [LOW] Knob/[HIGH] Knob	p. 36

Main Specifications

RD-300GX: Digital Piano

Keyboard Section	
Keyboard	88 keys (PHA alpha II Keyboard)
Sound Generator Section	
Conforms to General MIDI 2 System, 88-key Stereo Multi-sampled Piano Sound	
Part	16 Parts
Maximum Polyphony	128 voices
Wave Memory	128 MB (16-bit linear equivalent)
Tones	Normal Tones: 110 General MIDI 2 Tones: 256 Rhythm Sets: 5 General MIDI 2 Rhythm Sets: 9
Setups	32
Effects	Multi-Effects: 78 types Reverb: 6 types Sound Control 2-band Digital Equalizer
SMF/Audio File Player	
File Format	Standard MIDI File: format-0/1, Audio File: WAV, AIFF (44.1 kHz, 16-bit linear), MP3 Audio File can be played with Audio Key Function.
Connectors	
Connectors	Output Jacks (L/MONO, R): 1/4 inch phone type DAMPER Pedal CONTROL Pedal MIDI Connectors (IN, OUT) USB Connectors (MIDI, MEMORY) Headphones Jack: Stereo 1/4 inch phone type DC IN Jack
Dimensions/Weight	
Dimensions	1438 (W) x 337 (D) x 141 (H) mm 56-5/8 (W) x 13-5/16 (D) x 5-9/16 (H) inches
Weight	16.4 kg / 36 lbs 3 oz
Others	
Rhythm Patterns	200 patterns
Display	16 characters, 2 lines (Backlit LCD)
Controllers	Zone Level slider x 3 Equalizer knob x 2 Pitch Bend/Modulation lever Assignable Switches (S1, S2)
Internal Memory	1 M bytes
Power Supply	DC 9 V (AC Adaptor)
Power Consumption	11 W
Accessories	Owner's Manual CD-ROMs (Audio Key Utility 2, SONAR LE) Damper Pedal (DP-8) AC Adaptor, Power Cord

* In the interest of product improvement, the specifications and/or appearance of this unit are subject to change without prior notice.

Index

- A**
- AC Adaptor 16
 - Attack Time 69
 - Audio File 45
 - Audio Key 42
 - Audio Key 42
 - Volume 45
 - [AUDIO KEY] Button 13, 42
 - Audio Volume 67
- B**
- Bank Select LSB 56
 - Bank Select MSB 56
 - Bend Range 70
 - Bender Switch 71
 - Bulk Dump 77
- C**
- Center Cancel 76
 - Ch 55
 - Cho 58
 - Chorus
 - External Zone 58
 - Coarse Tune 70
 - Common 68
 - Connection
 - AC Adaptor 16
 - Computer 81
 - External Equipment 17
 - MIDI 54
 - MIDI Sequencer 78
 - Pedals 18
 - USB 54
 - USB Memory 21
 - Control Channel 65
 - CONTROL Jack 18
 - Control Pedal Function 68
 - Control Pedal Switch 71
 - Control Polarity 65
 - Copy SETUP 74
 - Copy SONG 74
 - Cord Hook 14, 16
 - Cutoff 69
- D**
- DAMPER Jack 18
 - Damper Noise 60
 - Damper Pedal Switch 71
 - Damper Polarity 65
 - DC IN Jack 14, 16
 - [DEC] Button 13
 - Decay Time 69
 - Delete SETUP 73
 - Delete SONG 75
 - DEMO PLAY 25
 - [DISPLAY CONTRAST] Knob 14, 20
 - [DUAL] Button 12, 28
 - Duplex Scale 61
- E**
- [EDIT] Button 13, 63
 - Edit Mode 63
 - Effects 47, 87
 - [ENTER] Button 13
 - EQ Mode 64
 - EQUALIZER Knobs 36
 - [EXIT/SHIFT] Button 13
 - External Zone 22, 53
 - [EXTERNAL/INTERNAL] Button 12, 55
- F**
- Factory Reset 77
 - Fast-forward
 - Song 41
 - File 72
 - Fine Tune 70
 - Format 76
 - Frequency 36
- G**
- Ground Terminal 14, 16
- H**
- Hammer Noise 61
 - [HIGH] Knob 12, 36
- I**
- [INC] Button 13
 - Indicator Mode 65
 - Internal Zone 22
- K**
- Key Off Resonance 61
 - Key Range
 - External Zone 59
 - Key Touch 62
 - Key Touch (Edit Mode) 67
 - Key Touch Mode 62
 - Key Touch Offset 62
 - Keynote 66
 - KRL 59
 - KRU 59

L	
Layer	28
Lid	60
Load SETUP	72
Local Control	78
Local Switch	79
[LOW] Knob	12, 36
LOWER	30
LOWER (External Zone)	55
Lower Tone	29
LSB	56
M	
Master Tune	64
Master Volume	64
MFX Type	87
MFX Zone	68
MIDI	53
MIDI Connectors	14, 53
MIDI OUT Channel	55
Modulation	34
Modulation Switch	71
MSB	56
Multi Effects	47, 68
Depth	47
Type	48
[MULTI EFFECTS] Button	12, 47
O	
ONE TOUCH [PIANO] Button	13, 60
OUTPUT Jacks	14
P	
Pan	
External Zone	58
Internal Zone	70
Panel Lock	49
Part	22
Part Mode	66
Part Switch	71
PC (Program Change)	56
Pedal	18
Pedal Function	68
PEDAL Jacks	14
PHONES Jack	14
Piano Designer	60
Pitch	70
Pitch Bend	34
Pitch Bend/Modulation Lever	12, 34
Play Mode	76
Playback	
Audio Files	40
Song	40
Playback Transpose	76
Polarity	65
Power	19
Power Cord	16
[POWER] Switch	14, 19
R	
Rec Mode	78
Recording	79
Release Time	69
Resonance	69
Rev	58
Reverb	
Depth	34
External Zone	58
Internal Zone	69
Piano Designer	60
Type	33
Reverb Amount	69
[REVERB] Button	12, 33
Reverb Depth	60
Rewind	
Song	41
RHY (Rhythm)	37
Rhythm	37
Pattern	38
Tempo	38
Volume	39
Rhythm Pattern List	97
Rhythm Set List	94
Rotary Effect	48
Rx. GM/GM2 System ON	67
Rx. GS Reset	67
S	
S1 Switch	71
S1/S2 Function	68
[S1] [S2] Buttons	12, 68
S2 Switch	71
Save	
Settings (Setup)	51
Save SETUP	72
Setup	50, 80, 98
Copy	74
Delete	73
Factory Reset	77
Load	72
Save	72
Write	51
[SETUP] Button	13, 50
SETUP Control Channel	65
SETUP Pedal Shift	64
Shortcut	98

SMF Music File	
Playback	40
Song	40
Copy	74
Delete	75
Fast-forward	41
Rewind	41
Tempo	41
Song Function	76
Song Stop Mode	67
[SONG/RHYTHM] Button	13, 37, 40
Sound Control	35
[SOUND CONTROL] Button	12, 35
Split	29
[SPLIT] Button	12, 29
Split Point	30
Stand	15
Stretch Tune	61
String Resonance	61
System	64

T

Temperament	66
Temperament Key	66
Tempo	
Audio Files	41
Rhythm	38
Song	41
Tone	22, 91
Tone List	91
Tone Parameter	69
TONE SELECT Buttons	13, 27
Transpose	
External Zone	58
Internal Zone	70
Keyboard	32
Song	76
[TRANSCOPE] Button	12, 32
Trs	58
Tuning	64

U

UPPER 1	28, 30
UPPER 1 (External Zone)	55
UPPER 2	28, 30
UPPER 2 (External Zone)	55
Upper Tone	29
USB Driver	65
USB Memory	21
USB MEMORY Connector	14
USB Memory Mode	65
USB MIDI Connector	14, 53, 81
USB MIDI Driver	81
Utility	77

V

Velocity	62
Velocity Delay Sense	62
V-LINK	82
Vol	58
Volume	
Audio File	67
Audio Key	45
External Zone	57–58
Internal Zone	31
Master	20, 64
Rhythm	39
VOLUME Slider	12, 20

W

[WRITE] Button	13, 51
----------------------	--------

Z

Zone	22
ZONE LEVEL Sliders	12, 31, 57
Zone Parameter	70
ZONE SELECT Button	13, 31
ZONE SELECT Indicators	13, 31

For EU Countries



- UK** This symbol indicates that in EU countries, this product must be collected separately from household waste, as defined in each region. Products bearing this symbol must not be discarded together with household waste.
- DE** Dieses Symbol bedeutet, dass dieses Produkt in EU-Ländern getrennt vom Hausmüll gesammelt werden muss gemäß den regionalen Bestimmungen. Mit diesem Symbol gekennzeichnete Produkte dürfen nicht zusammen mit dem Hausmüll entsorgt werden.
- FR** Ce symbole indique que dans les pays de l'Union européenne, ce produit doit être collecté séparément des ordures ménagères selon les directives en vigueur dans chacun de ces pays. Les produits portant ce symbole ne doivent pas être mis au rebut avec les ordures ménagères.
- IT** Questo simbolo indica che nei paesi della Comunità europea questo prodotto deve essere smaltito separatamente dai normali rifiuti domestici, secondo la legislazione in vigore in ciascun paese. I prodotti che riportano questo simbolo non devono essere smaltiti insieme ai rifiuti domestici. Ai sensi dell'art. 13 del D.Lgs. 25 luglio 2005 n. 151.
- ES** Este símbolo indica que en los países de la Unión Europea este producto debe recogerse aparte de los residuos domésticos, tal como está regulado en cada zona. Los productos con este símbolo no se deben depositar con los residuos domésticos.
- PT** Este símbolo indica que nos países da UE, a recolha deste produto deverá ser feita separadamente do lixo doméstico, de acordo com os regulamentos de cada região. Os produtos que apresentem este símbolo não deverão ser eliminados juntamente com o lixo doméstico.
- NL** Dit symbool geeft aan dat in landen van de EU dit product gescheiden van huishoudelijk afval moet worden aangeboden, zoals bepaald per gemeente of regio. Producten die van dit symbool zijn voorzien, mogen niet samen met huishoudelijk afval worden verwijderd.
- DK** Dette symbol angiver, at i EU-lande skal dette produkt opsamles adskilt fra husholdningsaffald, som defineret i hver enkelt region. Produkter med dette symbol må ikke smides ud sammen med husholdningsaffald.
- NO** Dette symbolet indikerer at produktet må behandles som spesialavfall i EU-land, iht. til retningslinjer for den enkelte regionen, og ikke kastes sammen med vanlig husholdningsavfall. Produkter som er merket med dette symbolet, må ikke kastes sammen med vanlig husholdningsavfall.

- SE** Symbolen anger att i EU-länder måste den här produkten kasseras separat från hushållsavfall, i enlighet med varje regions bestämmelser. Produkter med den här symbolen får inte kasseras tillsammans med hushållsavfall.
- FI** Tämä merkintä ilmaisee, että tuote on EU-maissa kerättävä erillään kotitalousjätteistä kunkin alueen voimassa olevien määräysten mukaisesti. Tällä merkinnällä varustettuja tuotteita ei saa hävittää kotitalousjätteiden mukana.
- HU** Ez a szimbólum azt jelenti, hogy az Európai Unióban ezt a terméket a háztartási hulladéktól elkülönítve, az adott régióban érvényes szabályozás szerint kell gyűjteni. Az ezzel a szimbóllummal ellátott termékeket nem szabad a háztartási hulladék közé dobni.
- PL** Symbol oznacza, że zgodnie z regulacjami w odpowiednim regionie, w krajach UE produktu nie należy wyrzucać z odpadami domowymi. Produktów opatrzonych tym symbolem nie można utylizować razem z odpadami domowymi.
- CZ** Tento symbol udává, že v zemích EU musí být tento výrobek sbírán odděleně od domácího odpadu, jak je určeno pro každý region. Výrobky nesoucí tento symbol se nesmí vyhazovat spolu s domácím odpadem.
- SK** Tento symbol vyjadruje, že v krajinách EÚ sa musí zber tohto produktu vykonávať oddelene od domového odpadu, podľa nariadení platných v konkrétnej krajine. Produkty s týmto symbolom sa nesmú vyhazovať spolu s domovým odpadom.
- EE** See sümbol näitab, et EL-i maades tuleb see toode olemprügist eraldi koguda, nii nagu on igas piirkonnas määratletud. Selle sümboliga märgitud tooteid ei tohi ära visata koos olmeprügiga.
- LT** Šis simbolis rodo, kad ES šalyse šis produktas turi būti surenkamas atskirai nuo buitinių atliekų, kaip nustatyta kiekvienoje regione. Šiuo simboliu paženklinėti produktai neturi būti išmetami kartu su buitinių atliekomis.
- LV** Šis simbols norāda, ka ES valstīs šo produktu jāievāc atsevišķi no mājsaimniecības atkritumiem, kā noteikts katrā reģionā. Produktus ar šo simbolu nedrīkst izmest kopā ar mājsaimniecības atkritumiem.
- SI** Ta simbol označuje, da je treba proizvod v državah EU zbirati ločeno od gospodinskih odpadkov, tako kot je določeno v vsaki regiji. Proizvoda tem znakom ni dovoljeno odlagati skupaj z gospodinskimi odpadki.
- GR** Το σύμβολο αυτό υποδηλώνει ότι στις χώρες της Ε.Ε. το συγκεκριμένο προϊόν πρέπει να συλλέγεται χωριστά από τα υπόλοιπα οικιακά απόβλητα, σύμφωνα με όσα προβλέπονται σε κάθε περιοχή. Τα προϊόντα που φέρουν το συγκεκριμένο σύμβολο δεν πρέπει να απορρίπτονται μαζί με τα οικιακά απόβλητα.

For China

有关产品中所含有害物质的说明

本资料就本公司产品中所含的特定有害物质及其安全性予以说明。
本资料适用于 2007 年 3 月 1 日以后本公司所制造的产品。

环保使用期限



此标志适用于在中国国内销售的电子信息产品，表示环保使用期限的年数。所谓环保使用期限是指在自制造日起的规定的期限内，产品中所含的有害物质不致引起环境污染，不会对人身、财产造成严重的不良影响。
环保使用期限仅在遵照产品使用说明书，正确使用产品的条件下才有效。
不当的使用，将会导致有害物质泄漏的危险。

产品中有毒有害物质或元素的名称及含量

部件名称	有毒有害物质或元素					
	铅(Pb)	汞(Hg)	镉(Cd)	六价铬(Cr(VI))	多溴联苯(PBB)	多溴二苯醚(PBDE)
外壳(壳体)	×	○	○	○	○	○
电子部件(印刷电路板等)	×	○	×	○	○	○
附件(电源线、交流适配器等)	×	○	○	○	○	○

○：表示该有毒有害物质在该部件所有均质材料中的含量均在 SJ/T11363-2006 标准规定的限量要求以下。
×：表示该有毒有害物质至少在该部件的某一均质材料中的含量超出 SJ/T11363-2006 标准规定的限量要求。
因根据现有的技术水平，还没有什么物质能够代替它。



For EU Countries

This product complies with the requirements of EMC Directive 2004/108/EC.

For the USA

FEDERAL COMMUNICATIONS COMMISSION RADIO FREQUENCY INTERFERENCE STATEMENT

This equipment has been tested and found to comply with the limits for a Class B digital device, pursuant to Part 15 of the FCC Rules. These limits are designed to provide reasonable protection against harmful interference in a residential installation. This equipment generates, uses, and can radiate radio frequency energy and, if not installed and used in accordance with the instructions, may cause harmful interference to radio communications. However, there is no guarantee that interference will not occur in a particular installation. If this equipment does cause harmful interference to radio or television reception, which can be determined by turning the equipment off and on, the user is encouraged to try to correct the interference by one or more of the following measures:

- Reorient or relocate the receiving antenna.
- Increase the separation between the equipment and receiver.
- Connect the equipment into an outlet on a circuit different from that to which the receiver is connected.
- Consult the dealer or an experienced radio/TV technician for help.

This device complies with Part 15 of the FCC Rules. Operation is subject to the following two conditions:

- (1) this device may not cause harmful interference, and
- (2) this device must accept any interference received, including interference that may cause undesired operation.

Unauthorized changes or modification to this system can void the users authority to operate this equipment.
This equipment requires shielded interface cables in order to meet FCC class B Limit.

For Canada

NOTICE

This Class B digital apparatus meets all requirements of the Canadian Interference-Causing Equipment Regulations.

AVIS

Cet appareil numérique de la classe B respecte toutes les exigences du Règlement sur le matériel brouilleur du Canada.

For the USA

DECLARATION OF CONFORMITY Compliance Information Statement

Model Name : RD-300GX
Type of Equipment : Digital Piano
Responsible Party : Roland Corporation U.S.
Address : 5100 S. Eastern Avenue, Los Angeles, CA 90040-2938
Telephone : (323) 890-3700

Roland®



* 0 4 8 9 9 5 9 0 - 0 2 *

04899590 08-02-2N

Free Manuals Download Website

<http://myh66.com>

<http://usermanuals.us>

<http://www.somanuals.com>

<http://www.4manuals.cc>

<http://www.manual-lib.com>

<http://www.404manual.com>

<http://www.luxmanual.com>

<http://aubethermostatmanual.com>

Golf course search by state

<http://golfingnear.com>

Email search by domain

<http://emailbydomain.com>

Auto manuals search

<http://auto.somanuals.com>

TV manuals search

<http://tv.somanuals.com>