

Owner's Manual

Thank you, and congratulations on your choice of the Roland Digital Piano FP-3.

Main Features

Stylish, Light, Compact Design

The refined design fits in anywhere; and since it is so lightweight and compact, it's easy to take the instrument with you wherever you go.

Authentic Piano Performances

High-quality concert grand piano tones, along with the Progressive Hammer Action keyboard, which gives more realistic piano touch by providing a heavier feel in the low end and a lighter feel in the upper notes, let you enjoy truly authentic piano performances.

Wide Variety of Tones For Use in Many Musical Genres

In addition to piano tones, the FP-3 offers 40 different onboard tones, which can be used for almost every conceivable style of music.

You can also play Drum Sets with the instrument.

"Session Partner" Lets You Enjoy Playing with a Session-Like Feel

Enjoy true session-like feel while performing along with a "Rhythm" section built upon realistic drum and bass sounds.

You can have the "Rhythm" chord progression advance automatically, or you can specify the chords to be played with your left hand.

Numerous Internal Songs

The FP-3 features four internal demo songs, along with a further fifty internal piano songs.

Experience a Variety of Performances with Dual and Split Functions

Layer two of the FP-3's many internal tones, play with different tones assigned to the left and right sections of the keyboard, and enjoy many other possibilities in working with Performances.

Keyboard Touch Can Be Set to Match Finger Strength

You can change the keyboard touch so it better suits the finger strength of the person playing the keyboard.

Easy Recording Functions

You can easily record your own performances using simple button operations.

Two Headphone Jacks Provided

The FP-3 comes equipped with two headphone jacks, allowing two people to use headphones simultaneously.

This is a convenient feature for use in lessons, or when playing pieces for four hands.

Includes Line In/Out Jacks

By connecting external audio equipment to the FP-3's Line Out jacks you can play sounds from the FP-3 through your audio setup, and with a CD player or other such device connected to the Line In jacks, you can then play internal sounds along with FP-3 Performances.

Before using this unit, carefully read the sections entitled: "USING THE UNIT SAFELY" and "IMPORTANT NOTES" (p. 2; p. 4). These sections provide important information concerning the proper operation of the unit. Additionally, in order to feel assured that you have gained a good grasp of every feature provided by your new unit, Owner's manual should be read in its entirety. The manual should be saved and kept on hand as a convenient reference.

IMPORTANT: THE WIRES IN THIS MAINS LEAD ARE COLOURED IN ACCORDANCE WITH THE FOLLOWING CODE.



BLUE: NEUTRAL
BROWN: LIVE

As the colours of the wires in the mains lead of this apparatus may not correspond with the coloured markings identifying the terminals in your plug, proceed as follows:
The wire which is coloured BLUE must be connected to the terminal which is marked with the letter N or coloured BLACK.
The wire which is coloured BROWN must be connected to the terminal which is marked with the letter L or coloured RED.
Under no circumstances must either of the above wires be connected to the earth terminal of a three pin plug.







USING THE UNIT SAFELY

INSTRUCTIONS FOR THE PREVENTION OF FIRE, ELECTRIC SHOCK, OR INJURY TO PERSONS

About  WARNING and  CAUTION Notices

 WARNING	Used for instructions intended to alert the user to the risk of death or severe injury should the unit be used improperly.
 CAUTION	Used for instructions intended to alert the user to the risk of injury or material damage should the unit be used improperly. * Material damage refers to damage or other adverse effects caused with respect to the home and all its furnishings, as well to domestic animals or pets.

About the Symbols

	The  symbol alerts the user to important instructions or warnings. The specific meaning of the symbol is determined by the design contained within the triangle. In the case of the symbol at left, it is used for general cautions, warnings, or alerts to danger.
	The  symbol alerts the user to items that must never be carried out (are forbidden). The specific thing that must not be done is indicated by the design contained within the circle. In the case of the symbol at left, it means that the unit must never be disassembled.
	The  symbol alerts the user to things that must be carried out. The specific thing that must be done is indicated by the design contained within the circle. In the case of the symbol at left, it means that the power-cord plug must be unplugged from the outlet.



ALWAYS OBSERVE THE FOLLOWING

WARNING

- Before using this unit, make sure to read the instructions below, and the Owner's Manual. 

- Do not open (or modify in any way) the unit or its AC adaptor. 



- Do not attempt to repair the unit, or replace parts within it (except when this manual provides specific instructions directing you to do so). Refer all servicing to your retailer, the nearest Roland Service Center, or an authorized Roland distributor, as listed on the "Information" page. 

- Never use or store the unit in places that are:
 - Subject to temperature extremes (e.g., direct sunlight in an enclosed vehicle, near a heating duct, on top of heat-generating equipment); or are 
 - Damp (e.g., baths, washrooms, on wet floors); or are 
 - Humid; or are
 - Exposed to rain; or are
 - Dusty; or are
 - Subject to high levels of vibration.

WARNING









- This unit should be used only with a rack or stand that is recommended by Roland. 

- When using the unit with a rack or stand recommended by Roland, the rack or stand must be carefully placed so it is level and sure to remain stable. If not using a rack or stand, you still need to make sure that any location you choose for placing the unit provides a level surface that will properly support the unit, and keep it from wobbling. 











- Be sure to use only the AC adaptor supplied with the unit. Also, make sure the line voltage at the installation matches the input voltage specified on the AC adaptor's body. Other AC adaptors may use a different polarity, or be designed for a different voltage, so their use could result in damage, malfunction, or electric shock. 

- Do not excessively twist or bend the power cord, nor place heavy objects on it. Doing so can damage the cord, producing severed elements and short circuits. Damaged cords are fire and shock hazards! 

⚠ WARNING

- This unit, either alone or in combination with an amplifier and headphones or speakers, may be capable of producing sound levels that could cause permanent hearing loss. Do not operate for a long period of time at a high volume level, or at a level that is uncomfortable. If you experience any hearing loss or ringing in the ears, you should immediately stop using the unit, and consult an audiologist. 
- Do not allow any objects (e.g., flammable material, coins, pins); or liquids of any kind (water, soft drinks, etc.) to penetrate the unit. 

- Immediately turn the power off, remove the AC adaptor from the outlet, and request servicing by your retailer, the nearest Roland Service Center, or an authorized Roland distributor, as listed on the "Information" page when: 
 - The AC adaptor, the power-supply cord, or the plug has been damaged; or
 - Objects have fallen into, or liquid has been spilled onto the unit; or
 - The unit has been exposed to rain (or otherwise has become wet); or
 - The unit does not appear to operate normally or exhibits a marked change in performance.
- In households with small children, an adult should provide supervision until the child is capable of following all the rules essential for the safe operation of the unit. 
- Protect the unit from strong impact. (Do not drop it!) 
- Do not force the unit's power-supply cord to share an outlet with an unreasonable number of other devices. Be especially careful when using extension cords—the total power used by all devices you have connected to the extension cord's outlet must never exceed the power rating (watts/amperes) for the extension cord. Excessive loads can cause the insulation on the cord to heat up and eventually melt through. 
- Before using the unit in a foreign country, consult with your retailer, the nearest Roland Service Center, or an authorized Roland distributor, as listed on the "Information" page. 

⚠ CAUTION

- The unit and the AC adaptor should be located so their location or position does not interfere with their proper ventilation. 
- Always grasp only the plug on the AC adaptor cord when plugging into, or unplugging from, an outlet or this unit. 
- Whenever the unit is to remain unused for an extended period of time, disconnect the AC adaptor. 
- Try to prevent cords and cables from becoming entangled. Also, all cords and cables should be placed so they are out of the reach of children. 
- Never climb on top of, nor place heavy objects on the unit. 
- Never handle the AC adaptor or its plugs with wet hands when plugging into, or unplugging from, an outlet or this unit. 
- Before moving the unit, disconnect the AC adaptor and all cords coming from external devices. 
- Before cleaning the unit, turn off the power and unplug the AC adaptor from the outlet (p. 8). 
- Whenever you suspect the possibility of lightning in your area, disconnect the AC adaptor from the outlet. 
- Should you remove the screws fastening the music stand or stand, make sure to put them in a safe place out of children's reach, so there is no chance of them being swallowed accidentally. 

IMPORTANT NOTES

In addition to the items listed under “USING THE UNIT SAFELY” on page 2 and 3, please read and observe the following:

Power Supply

- Do not use this unit on the same power circuit with any device that will generate line noise (such as an electric motor or variable lighting system).
- The AC adaptor will begin to generate heat after long hours of consecutive use. This is normal, and is not a cause for concern.
- Before connecting this unit to other devices, turn off the power to all units. This will help prevent malfunctions and/or damage to speakers or other devices.

Placement

- Using the unit near power amplifiers (or other equipment containing large power transformers) may induce hum. To alleviate the problem, change the orientation of this unit; or move it farther away from the source of interference.
- This device may interfere with radio and television reception. Do not use this device in the vicinity of such receivers.
- Do not expose the unit to direct sunlight, place it near devices that radiate heat, leave it inside an enclosed vehicle, or otherwise subject it to temperature extremes. Excessive heat can deform or discolor the unit.
- To avoid possible breakdown, do not use the unit in a wet area, such as an area exposed to rain or other moisture.
- Do not allow objects to remain on top of the keyboard. This can be the cause of malfunction, such as keys ceasing to produce sound.
- Do not leave this instrument standing on end for more than approximately two weeks. Doing so can adversely impact the keyboard's functionality.
- Do not paste stickers, decals, or the like to this instrument. Peeling such matter off the instrument may damage the exterior finish.

Maintenance

- For everyday cleaning wipe the unit with a soft, dry cloth or one that has been slightly dampened with water. To remove stubborn dirt, use a cloth impregnated with a mild, non-abrasive detergent. Afterwards, be sure to wipe the unit thoroughly with a soft, dry cloth.
- Never use benzine, thinners, alcohol or solvents of any kind, to avoid the possibility of discoloration and/or deformation.

Additional Precautions

- Use a reasonable amount of care when using the unit's buttons, sliders, or other controls; and when using its jacks and connectors. Rough handling can lead to malfunctions.
- Never strike or apply strong pressure to the display.
- When connecting / disconnecting all cables, grasp the connector itself—never pull on the cable. This way you will avoid causing shorts, or damage to the cable's internal elements.
- To avoid disturbing your neighbors, try to keep the unit's volume at reasonable levels. You may prefer to use headphones, so you do not need to be concerned about those around you (especially when it is late at night).
- When you need to transport the unit, package it in the box (including padding) that it came in, if possible. Otherwise, you will need to use equivalent packaging materials.
- Use only the specified expression pedal (EV-5; sold separately). By connecting any other expression pedals, you risk causing malfunction and/or damage to the unit.
- Use a cable from Roland to make the connection. If using some other make of connection cable, please note the following precautions.
 - Some connection cables contain resistors. Do not use cables that incorporate resistors for connecting to this unit. The use of such cables can cause the sound level to be extremely low, or impossible to hear. For information on cable specifications, contact the manufacturer of the cable.

Stand (FPS-10A: sold separately)

Cautions When Handling the Speaker Stand

- To prevent accidents caused by falling speakers, do not use the speaker stands included with the stand FPS-10A in combination with any other instrument or product.
- Be sure to use the provided velcro tape to keep the speakers fixed to where they are set on the speaker stands.
- Setting the speakers sideways to increase power may cause the velcro tape to separate, making it easier for the speakers to fall; exercise due caution.

• Please use Roland speakers that meet the following requirements:
<Weight: 10 kg or less;
Dimensions: 210 (W) x 280 (D) x 330 (H) mm or less>
When installed in combination with speakers other than one described above, Roland no assurance as to the stability thereof. Before attempting such use, be sure to check carefully to ensure that stable installation continued stability during use are possible.

- Merely screwing in the speaker stand attachment screws as is without the proper preparation may result in damage to the unit. Be absolutely sure to attach the speaker stand attachment screws to the speaker stands.

Contents

USING THE UNIT SAFELY	2
IMPORTANT NOTES	4
Contents.....	5
Panel Descriptions	6
Before You Play	8
Making Connections.....	8
Installing the Music Stand	9
Connecting Pedals.....	10
Turning the Power On and Off.....	10
Adjusting the Sound's Volume and Brilliance.....	11
Connecting Headphones.....	11
Chapter 1 Playing the Keyboard.....	12
Listening to Internal Songs.....	12
Playing Back All Songs Continuously (All Song Play).....	12
Listening to Each Part Separately.....	13
Performing with a Variety of Sounds	14
Performing With Two Layered Tones (Dual Play)	15
Performing With Different Tones in the Left and Right Sides of the Keyboard (Split Play)	16
Changing Tones	17
Changing the Keyboard's Split Point	17
Changing the Volume Balance for Dual Play and Split Play.....	18
Changing the Keyboard's Touch	19
Adding Breadth to the Sound (Chorus Effect).....	20
Adding a Spinning Sound to Organ Tones (Rotary Effect).....	20
Changing the Depth of Chorus Effect.....	20
Adding Reverberation to Sounds (The Reverb Effect) .	21
Changing the Depth of Reverb Effect	21
Transposing the Key of the Keyboard (Key Transpose)	22
Using the Metronome.....	23
Changing the Tempo.....	23
Changing the Beat of Metronome	24
Changing the Volume	24
Chapter 2 Playing Along with Rhythms	25
What is Session Partner?	25
Performing Along With Rhythms	26
Performing Along With Drum Sounds	26
Performing With Chord Parts.....	26
About the lighting of the [Drum] and [Chord] button indicators	27
Selecting a Rhythm	28
Changing Rhythms As You Perform	28
Changing a Rhythm's Tempo.....	29
Selecting a Rhythm's Chord Progression	30
Performing With the Chord Progression Specified in the Left Hand (Rhythm Split Play).....	31
Changing the Volume Balance Between the Keyboard and the Rhythm.....	32
Chapter 3 Recording a Performance ...	33
Recording a Performance.....	33
Recording a Performance Using Rhythms.....	34
Recording a Performance Using Rhythms (in Split Play)	35
Recording Selected Track buttons	36
Erasing Recorded Performances	37
Correspondence Between Recorded Performance and Track Buttons	37
Chapter 4 Other Functions	38
Changing the Damper Pedal's Resonance.....	38
Changing How the Pedals Work	38
Changing How the Pedal Effects Are Applied.....	39
Changing the Pitch of the Lower Tone in Octave Steps (Octave Shift)	39
Tuning to Other Instruments' Pitches (Master Tuning) .	40
Adjusting the Tuning.....	40
Changing the Beat Pattern	41
Connecting MIDI Devices.....	42
Appendices	45
Troubleshooting	45
Error Messages/Other Messages.....	47
Tone List	48
Rhythm List.....	49
Chord Progression Pattern List.....	50
Chord Fingering List	52
Internal Song List	54
Easy Operation List.....	56
MIDI Implementation.....	57
Main Specifications	58
Index.....	59

Panel Descriptions

Front Panel

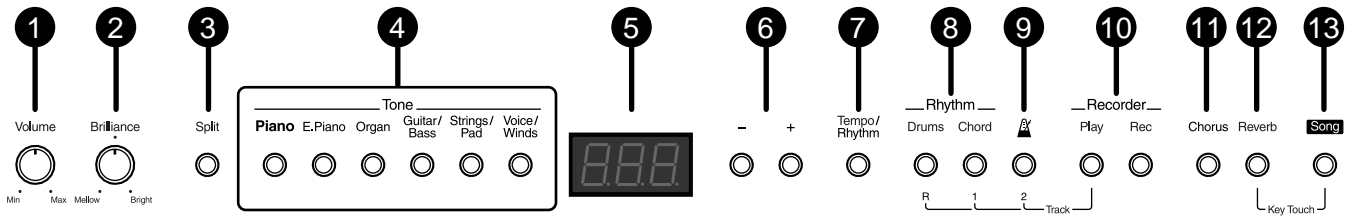

1 [Volume] Knob

Adjusts the overall volume level (p. 11).

2 [Brilliance] Knob

Adjusts the tone brightness (p. 11).

3 [Split] Button

Allows you to play different tones in the left and right sides of the keyboard (p. 16) and specify Rhythm chords with the left hand (p. 31).

4 Tone Buttons

They are used to choose the kinds of sounds (Tone Groups) played by the keyboard (p. 14).

5 Display

Displays information such as the song number, Rhythm number, tempo, beat, and parameter settings values.

6 [-]/[+] Buttons

These two buttons are used to modify the values of a variety of settings. Pressing both the [-] and [+] buttons simultaneously returns the setting of a particular item or function to its default value. Additionally, with certain settings, the indicators of these buttons may change color when the settings are changed.

7 [Tempo/Rhythm] Button

Press this to change the tempo or Rhythm (p. 23, p. 28)

8 Rhythm Button

Switches each Rhythm on or off.

Use these two buttons to determine whether a Rhythm is to be played in each individual part.

[Drums] Button

Turns the Rhythm Drum part on and off (p. 26).

Press this button when you want to stop both the Drum and Chord parts.

[Chord] Button

Turns the Rhythm Drum part and Chord part on and off. You can also turn only the Chord part off (p. 26).

9 [Metronome] Button

Turns the internal metronome on and off (p. 23).

10 Recorder Buttons

Used for playing back and recording performances. Such operations employ the following two buttons.

[Play] Button

Starts and stops playback of internal songs and recorded performances (p. 12).

Used for starting recording of performances (p. 33).

Can also be used to force-stop Rhythms (p. 26).

[Rec] button

Puts the unit in the state whereby it is ready for recording performances (p. 33).

11 [Chorus] Button

You can use this to add three-dimensional breadth and "fatness" to sounds (p. 20).

12 [Reverb] Button

You can use this to add the characteristic reverberation of a concert hall to what you play (p. 21).

13 [Song] Button

For selecting internal songs (p. 12).

By holding down this button and pressing the [Reverb] button, you can change the keyboard's touch sensitivity (p. 19).

In addition, you can hold down this button while pressing other specified buttons to make various different settings (p. 38 to p. 44).

Rear Panel

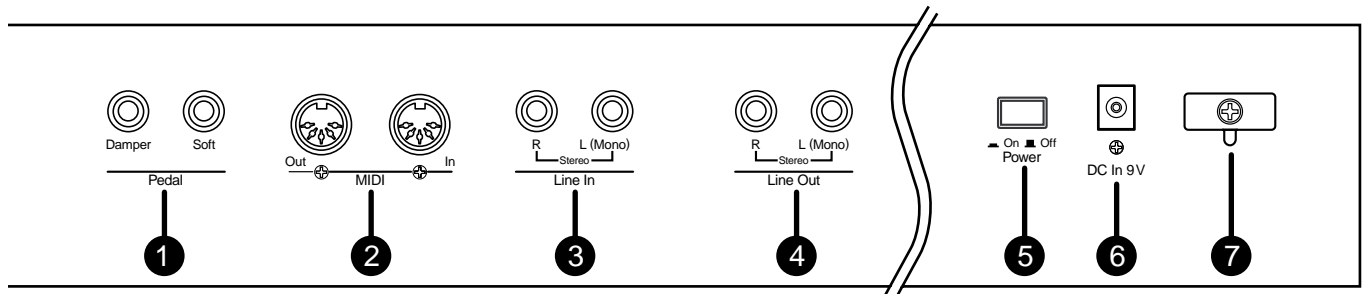

1 Pedal Jacks

Accepts connection of the supplied pedal , or other suitable pedals (p. 10).

2 MIDI Connectors

You can connect external MIDI devices to the FP-3 and exchange performance data among them (p. 42).

3 Line In Jacks

Provide input of the audio signals. Used for connecting audio equipment and other such devices (p. 8).

4 Line Out Jacks

Provide output of the audio signals. Also used for connecting audio equipment and other such devices (p. 8).

These allow you to play sounds from the FP-3 through other audio devices.

5 [Power] Switch

This switch turns the unit on/off (p. 10).

6 DC In Jack

Connect the supplied AC adaptor here (p. 8).

7 Cord Hook

Use this to fix in place the cord from the supplied AC adaptor (p. 8).

Before You Play

Making Connections

The FP-3 does not contain an amp or speakers. To hear sound, either connect an amplifier and speakers, or use stereo headphones.

* *MIDI cable and stereo headphones are not included. Consult your Roland dealer if you need to purchase accessories such as these.*

NOTE

To prevent malfunction and/or damage to speakers or other devices, always turn down the volume, and turn off the power on all devices before making any connections.

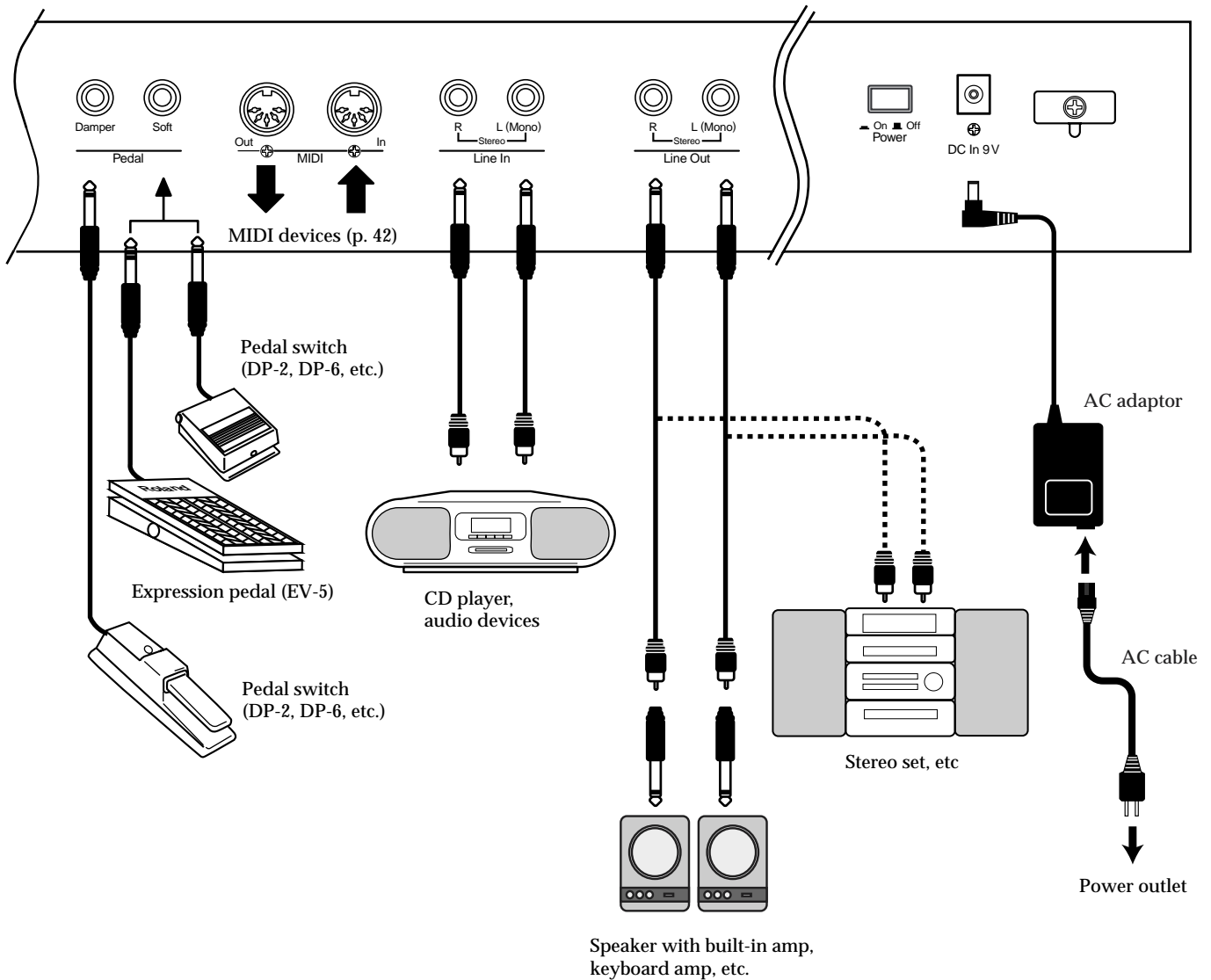

1. Before you begin making connections, confirm the following.

Is the volume level of the FP-3 or connected amp turned all the way down?

Is the power to the FP-3 or connected amp turned off?

2. Connect the supplied AC adaptor to the FP-3, and then plug its other end into a power outlet.

To prevent the inadvertent disruption of power to your unit (should the plug be pulled out accidentally), and to avoid applying undue stress to the DC In jack, anchor the power cord using the cord hook, as shown in the illustration.

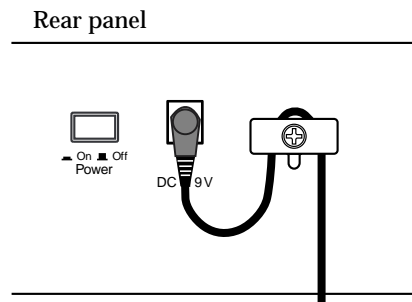

3. Connect the amp or audio gear to the Line Out jacks as shown in the diagram.

In order to take full advantage of the FP-3's sound we recommend that you play it in stereo.

When using the system in mono, connect to the Line Out L (Mono) jack.

→ If you are using headphones, refer to "Connecting Headphones" (p. 11).

→ For instructions on connecting to the Pedal jacks, refer to "Connecting Pedals" (p. 10).

→ For instructions on connecting to the MIDI connectors, refer to "Connecting MIDI Devices" (p. 42).

Installing the Music Stand

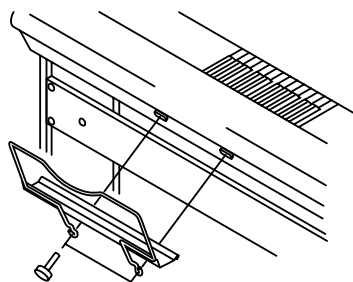

1. Using the supplied screws, fasten the music stand to the back of the FP-3 as illustrated.

Be sure to use the supplied screws for attaching the music stand.

Turn the screws clockwise to tighten them.

When attaching the music stand, support it firmly with one hand to make sure that you do not drop it. Be careful, so you do not get your fingers pinched.

2. To remove the music stand, support it with one hand while loosening the screws.

NOTE

Do not apply excessive force to the installed music stand.

Before You Play

Connecting Pedals

1. Connect the pedal included with the FP-3 to one of the Pedal jacks.

When connected to the Damper jack, the pedal can be used as a damper pedal.

When connected to Soft, the pedal can be used as a soft pedal.

- * *Unplugging a pedal cord from the unit while the power is on may cause the pedal's effect to be applied without stopping. The power of the FP-3 must be turned off before inserting or removing a pedal cord.*

Damper Pedal

Use this pedal to sustain the sound. While the pedal is depressed, long lingering reverberations continue to be added to the sound after you release from the keys.

When you depress the damper pedal on an acoustic piano, the sound from the strings that were struck resonates with other strings, adding rich reverberations and broadness to the sound. You can adjust this resonance (sympathetic resonance) when the damper pedal is depressed.

- * *The amount of the resonance obtained with the Damper pedal can be changed. For more information and instructions, please refer to "Changing the Damper Pedal's Resonance" (p. 38).*

Soft Pedal

This pedal is used to make the sound softer.

Playing with the soft pedal depressed produces a sound that is not as strong as when otherwise played with the equivalent strength. This is the same function as the left pedal of an acoustic piano.

- * *When connected to the Soft Pedal jack, the pedal may also be used as a sostenuto pedal or expression pedal. For more information and instructions, please refer to "Changing How the Pedals Work" (p. 38).*
- * *By obtaining a second pedal, you can then use two pedals simultaneously. If you wish to purchase the optional pedal (DP-2/DP-6), please contact the dealer where you purchased the FP-3.*

Turning the Power On and Off

Once the connections have been completed, turn on or off power to your various devices in the order specified. By turning on devices in the wrong order, you risk causing malfunction and/or damage to speakers and other devices.

■ Turning On the Power

1. Before you switch on the power, turn the volume down all the way by rotating the [Volume] knob.

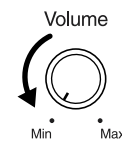

Also completely turn down the volume of any connected audio device and other equipment.

2. Press the [Power] switch on the back of the unit.

After a few seconds, the unit becomes operable and playing the keyboard produces sound.

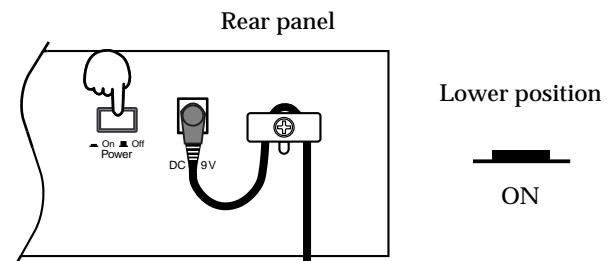

- * *This unit is equipped with a protection circuit. A brief interval (a few seconds) after power up is required before the unit will operate normally.*

3. Turn on the power of the connected external equipment.

4. Adjust the volume of the connected external device.

5. Adjust the FP-3's volume to obtain the proper volume level.

■ Turning Off the Power

- 1. Before switching the power off, turn the volume all the way down by rotating the [Volume] knob.**
Also completely turn down the volume of any connected audio device and other equipment.
- 2. Turn off the power to the connected external equipment.**
- 3. Press the [Power] switch on the back of the unit.**
The power is switched off.

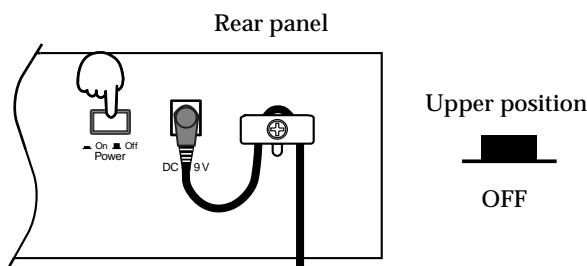

Adjusting the Sound's Volume and Brilliance

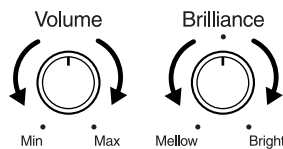

- 1. Use the [Volume] knob to adjust the overall volume level.**
Rotating the knob clockwise increases the volume; counterclockwise rotation decreases it.
- 2. Use the [Brilliance] knob to adjust the overall sound quality.**
Rotating the knob clockwise makes the tone brighter; rotating it counterclockwise makes the sound more subdued.

Connecting Headphones

Connecting headphones allows you to enjoy playing anytime, even at night, without concern.

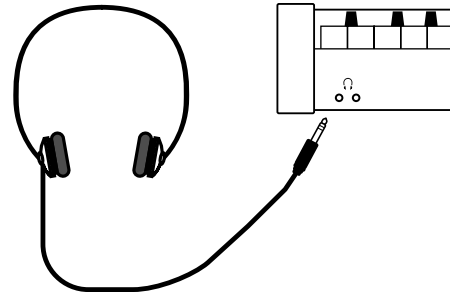

- 1. Plug the headphones into the Phones jack at the front, on the left side of the piano.**
Use the [Volume] knob on the FP-3 to adjust the volume of the headphones.
** Make sure to use stereo headphones.*

Some Notes on Using Headphones

- To prevent damage to the cord, handle the headphones only by the headset or the plug.
- The headphones may be damaged if the volume is too high when they are plugged in. Lower the volume on the FP-3 before plugging in the headphones.
- To prevent possible auditory damage, loss of hearing, or damage to the headphones, the headphones should not be used at an excessively high volume. Use the headphones at a moderate volume level.

Chapter 1 Playing the Keyboard

Listening to Internal Songs

Now, try listening to internal songs
The FP-3 comes with fifty four internal songs.



For more on internal song names, refer to “Internal Song List” (p. 54).

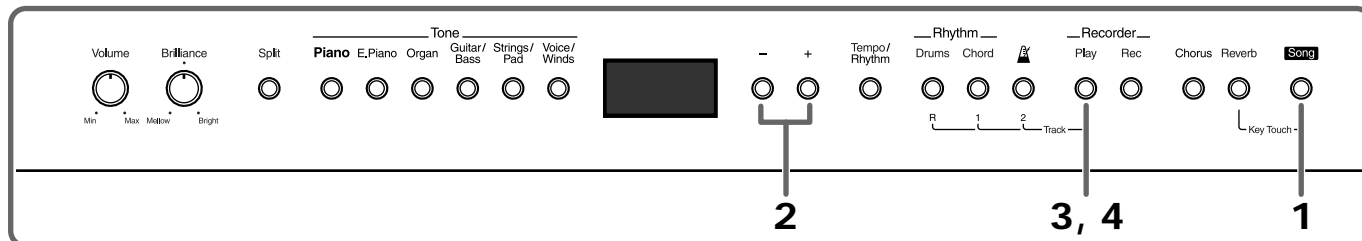

1. Press the [Song] button, getting its indicator to light.

The following appears in the display.



2. Press the [-] or [+] button to select the song.

3. Press the [Play] button.

The song will begin playing back.

The selected song is played to the end, and then playback stops.

4. To stop playback, press the [Play] button once more.

The next time you press the [Play] button, the song that was stopped is played from the beginning.



About the Display of the Internal Songs

USr (User)—Stores recorded Performances (for more on recording →p. 33).
When “d.” is added—
Indicates one of the demo songs that make use of the FP-3’s various internal tones.

When “P.” is added—
Indicates one of the piano songs

NOTE

You cannot play the internal song and Rhythm (p. 26) at the same time.

■ Playing Back All Songs Continuously (All Song Play)

Listening to all of internal songs repeatedly played back in succession is known as “All Song Play.”

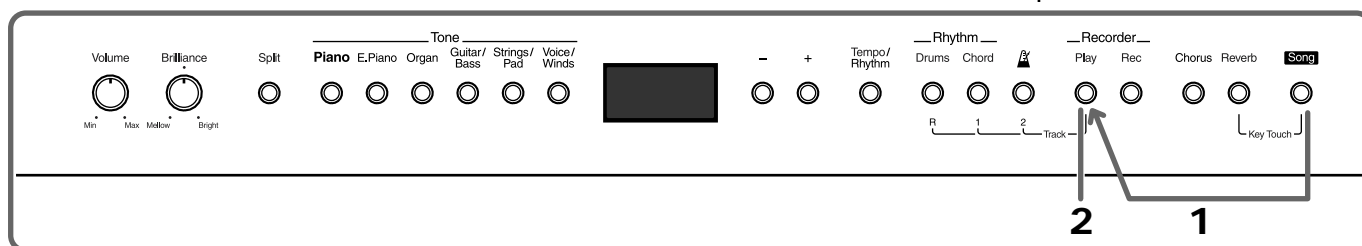

1. Hold down the [Song] button and press the [Play] button.

Songs play back continuously.

When playback of the last song is reached, playback continues by returning to the first song and playing that again.

2. To stop playback, press the [Play] button.

All Song Play is exited when the performance is stopped.

The next time you press the [Play] button, the song that was stopped is played from the beginning.



When you change the volume balance between the keyboard and the Rhythm, the volume balance between the keyboard and the internal song may change. Refer to “Changing the Volume Balance Between the Keyboard and the Rhythm”

When the following appears in the display

If there is any performance data stored in the FP-3's memory, the following appears in the display.

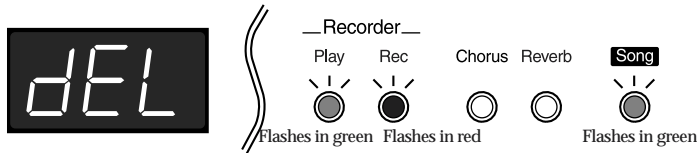

Until you erase the performance data, you cannot play back an internal song.

To erase the performance data and play back the internal song, press the [Rec] button.

If you don't want to erase the song, press the [Play] or [Song] button.

■ Listening to Each Part Separately

With the internal songs, you can select the performance part that is to be played back.

With Piano songs 1 to 50, you can also practice each hand separately while playing along with the song.

- 1. Select the song to be played back.**
- 2. Hold down the [Play] button and press the button, either [Chord (1)] or [A (2)], for the part that is not to be played back.**

The indicator on the selected button goes out.

The performance data is assigned to the Track buttons as shown below.

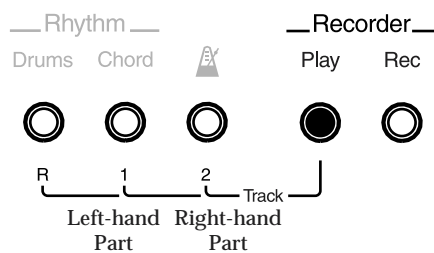

- 3. Press the [Play] button.**
The song will begin playing back.
The sound for the performance part selected in Step 2 is not played.
Temporarily preventing the sounds of a specified part from playing is called "muting."
- 4. Hold down the [Play] button and press the button selected in Step 2.**

The sound of the muted part is then played.

Performing with a Variety of Sounds

The FP-3 features 40 different internal sounds, allowing you to enjoy performing with sounds suitable for many different types of music.

These onboard sounds are called “Tones.” The Tones are divided into six different groups, each of which is assigned to a different Tone button.

The Tone “Grand Piano 1” is selected when the instrument’s power is turned on.



For more on Tones, refer to “Tone List” (p. 48)

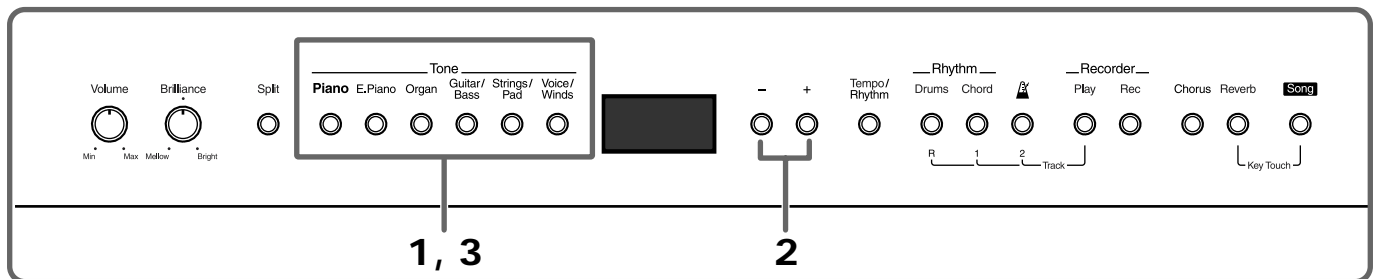

1. Press one of the Tone buttons to choose a Tone Group.

You’ll hear the Tone assigned to Tone number 1 in the selected Tone Group. Try fingering the keyboard.

The Tone number appears in the display.



When you press the Tone button, the [-] and [+] buttons light in orange.

2. Press the [-] or [+] button to select a Tone from the Tone Group.

The indicator for the selected Tone button flashes, showing that the tone has been selected.

3. Finger the keyboard or press the flashing Tone button.

The Tone button’s indicator lights up, and you can check the sound. The Tone you’ve selected is heard when you finger the keyboard.

The next time you choose this Tone button, the tone you’ve selected here is played.

Performing With Two Layered Tones (Dual Play)

You can play two different sounds from a single key at the same time. This method of performance is called “Dual Play.”

Example: Try Layering Piano and String Tones

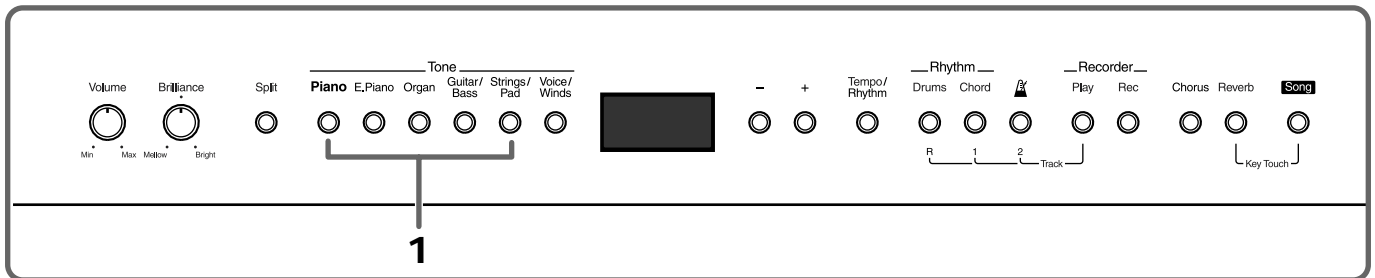

1. Press the [Piano] button and the [Strings/Pad] button at the same time.

The indicators for both buttons light.

Try fingering the keyboard.

Both the piano and string sounds play.

Pressing two Tone buttons at the same time in this manner activates Dual Play.

In Dual Play, the Tone for the left button you press is called the “Upper Tone,” and the Tone for the right button is called the “Lower Tone.”

The Tone button’s indicator lights in orange for the Upper Tone, and in red for the Lower Tone.

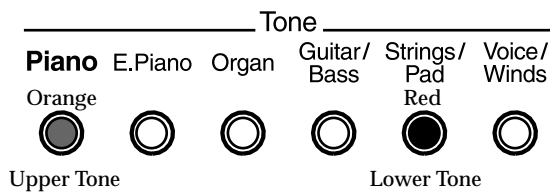

Here, the piano tone is the Upper Tone and the strings tone is the Lower Tone.

2. To exit Dual Play, press either Tone button.

Now, only the tone of the button you just pressed is sounded.

Switching the Upper Tone and Lower Tone

When in Dual Play, you can together press both of the Tone buttons for the two currently selected tones a second time to assign the tone of the left button to the Lower Tone, and the tone of the right button to the Upper Tone.

You can easily switch between two tones, which is useful for times such as when you have things set so the pedal’s effect is not applied to the Lower Tone (see “MEMO”).

MEMO

You can change the pitch of the Lower Tone an octave at a time. Refer to “Changing the Pitch of the Lower Tone in Octave Steps (Octave Shift)” (p. 39).

MEMO

You can vary the volume-level balance of the two tones. Take a look at “Changing the Volume Balance for Dual Play and Split Play” (p. 18).

MEMO

Although when you press the pedal while in Dual Play, the effect is applied to both tones, you can set the FP-3 so that the effect is not applied to the Lower Tone. Refer to “Changing How the Pedal Effects Are Applied” (p. 39).

Performing With Different Tones in the Left and Right Sides of the Keyboard (Split Play)

Performing with the keyboard divided at a certain key into a left side and a right side is called “Split Play,” and the point at which the keyboard is divided is called the “split point.”

In Split Play, you can have a different tone sound in the left and right sides. Furthermore, when you use the Rhythm in performances, you can specify chords with the keys in the left-hand part (for more detailed instructions, refer to “Performing With the Chord Progression Specified in the Left Hand (Rhythm Split Play)” (p. 31)).

When the instrument is turned on, the split point is set to “F # 3.” The split point key is included in the left side.

While in Split Play, a sound played in the right side is called an “Upper Tone,” and the sound played in the left side is called a “Lower Tone.”

Example: Let’s try split play with the piano tones.

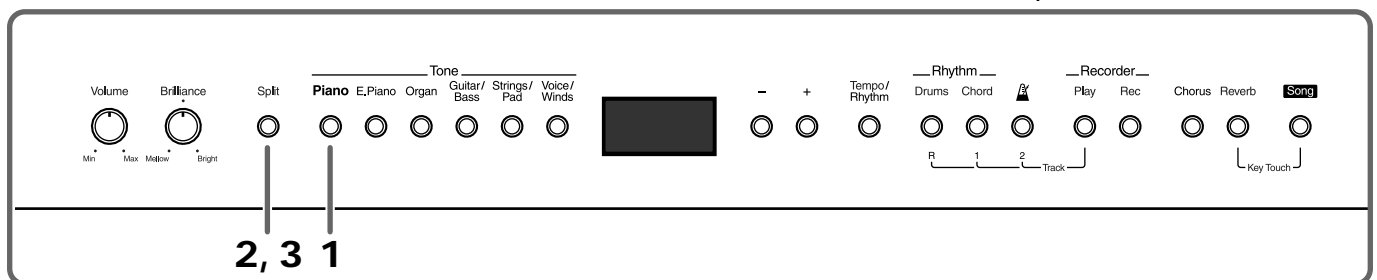

- 1. Press the [Piano] button.**
Now, the piano tone is selected.
- 2. Press the [Split] button, getting its indicator to light.**
The keyboard is divided into upper and lower sections.

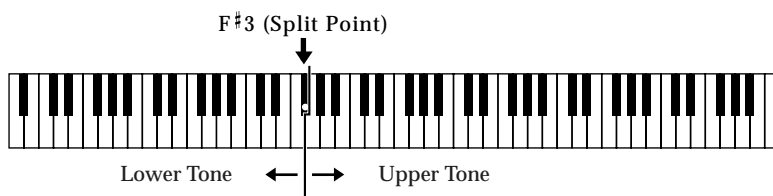

The right-hand section of the keyboard plays piano tone, and the left-hand section plays Acoustic Bass+Cymbal tone.

You can play a tone for the right side (the Upper Tone) before splitting the keyboard.

The Tone button’s indicator lights in orange for the Upper Tone, and in red for the Lower Tone.

- 3. To exit Split Play, press the [Split] button once more.**
The [Split] button’s indicator light goes out and the upper tone becomes the tone for the entire keyboard.



When you switch from Dual Play (p. 15) to Split Play, the Upper Tone used in Dual Play is selected as the Upper Tone for Split Play.



You can vary the volume-level balance of the two tones. Take a look at “Changing the Volume Balance for Dual Play and Split Play” (p. 18).

■ Changing Tones

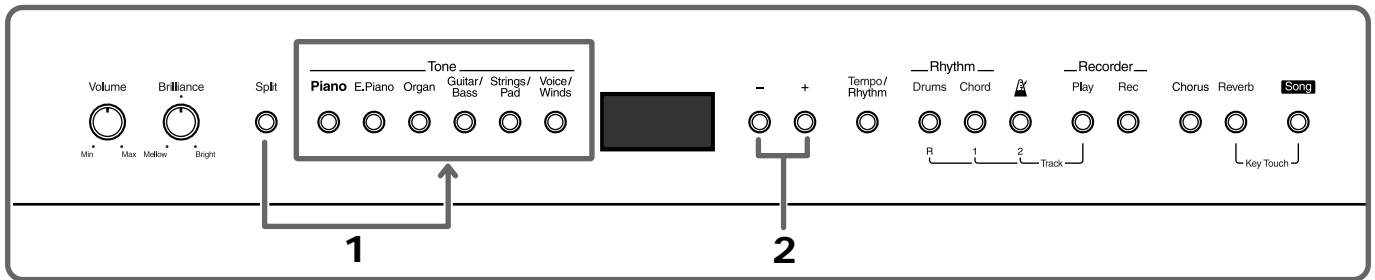

1. Hold down the [Split] button and press the Tone button for the tone you want to change, whether the Upper or Lower Tone.

The indicators for the [-] and [+] buttons light in the same color as the indicator of the selected tone button.

When orange, it indicates that the Upper Tone can be changed; when red, it is the Lower Tone that is being changed.

2. Use the Tone buttons and the [-] and [+] buttons to select the Tones.

For more on selecting tones, refer to “Performing with a Variety of Sounds” (p. 14).

■ Changing the Keyboard’s Split Point

You can change the location where the keyboard is divided (the split point) within the range of B1 through B6.

This is set to “F # 3” when the instrument is turned on.

This setting remains in effect until you turn off the power.

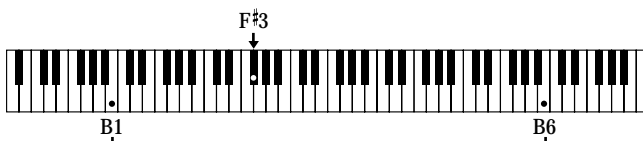

1. Hold down the [Split] button and press a key set as the split point.

The key you pressed becomes the split point, and belongs to the left-hand section of the keyboard.

While the [Split] button is held down, the key being used as the split point appears in the display.

With the [Split] button held down, you can change the value, even by pressing the [-] or [+] button.

Additionally, by holding down the [Split] button and pressing the [-] or [+] button one time, you can display the currently selected value.

When you release the [Split] button, you return to the previous screen.

MEMO

When the tone of the same Tone button is selected for both the Upper and Lower Tones, you can determine which of the Tones is being changed by the color of the indicators for the [-] and [+] buttons.

MEMO

You can change the pitch of the Lower Tone an octave at a time. Refer to “Changing the Pitch of the Lower Tone in Octave Steps (Octave Shift)” (p. 39).

MEMO

The name of the key acting as the split point is indicated in the display, as shown below.

Display	C	d ₋	d	E ₋
Letter name	C	D _b	D	E _b
Display	E	F	F ₋	G
Letter name	E	F	F _#	G
Display	A ₋	A	b ₋	b
Letter name	A _b	A	B _b	B

MEMO

By holding down the [Split] button and pressing both the [-] and [+] buttons simultaneously, the setting returns to its original value.

Changing the Volume Balance for Dual Play and Split Play

You can change the volume balance of the Upper and Lower Tones in Dual Play (p. 15) and Split Play (p. 16).

When the instrument is turned on, this is set to “5-5” (“Lower Tone volume”-“Upper Tone volume”).

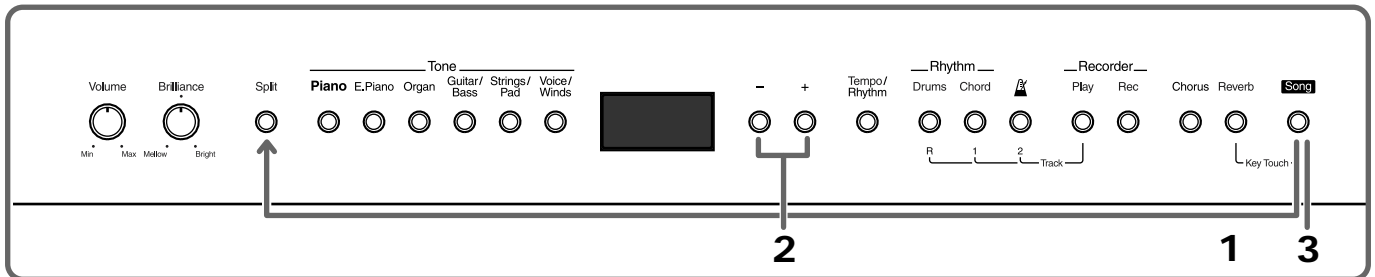

1. Hold down the [Song] button and press the [Split] button.

The indicators for the [Song] and [Split] buttons flash in red.



Lower Tone volume (The Tone button's indicator light is red) Upper Tone volume (The Tone button's indicator light is Orange)

2. Press the [-] or [+] buttons to adjust the volume balance.

To restore the normal default volume balance, press the [-] and [+] buttons simultaneously.

3. Press the [Song] button.

The indicators return to their previous state.

Changing the Keyboard's Touch

You can change the touch sensitivity, or response of the keys.

When the instrument is turned on, this is set to "Normal."

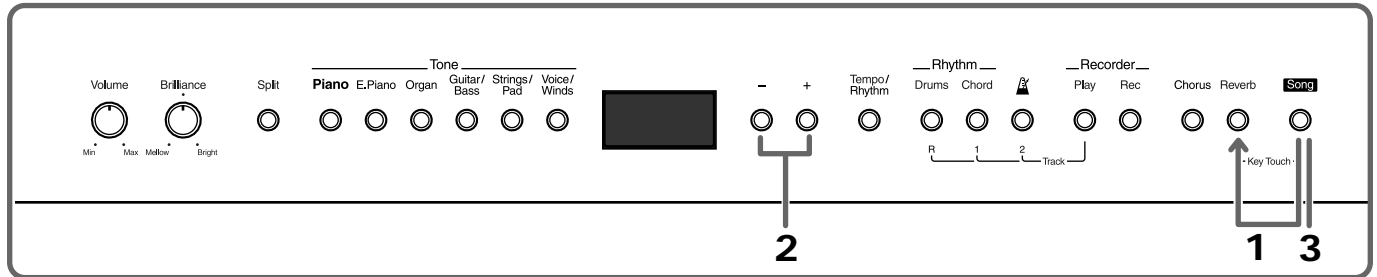

1. Hold down the [Song] button and press the [Reverb] button.

The indicators for the [Song] and [Reverb] buttons flash in red.



2. Press the [-] or [+] buttons to select the touch.

Indicate	Description
OFF (Fixed)	The sound plays at one set volume, regardless of the force used to play the keys.
1 (Light)	A light keyboard touch is selected. You can achieve fortissimo (ff) play with a less forceful touch than usual, so the keyboard feels lighter. This setting makes it easy to play, even for children.
2 (Normal)	This sets the standard keyboard touch. You can play with the most natural touch. This is the closest to the touch of an acoustic piano.
3 (Heavy)	Here, a heavy keyboard touch is selected. You have to finger the keyboard more forcefully than usual in order to play fortissimo (ff), so the keyboard touch feels heavier. Dynamic fingering adds even more feeling to what you play.

3. Press the [Song] button.

The indicators return to their previous state.

Adding Breadth to the Sound (Chorus Effect)

You can apply a chorus effect to the notes you play on the keyboard. By adding the chorus effect, you can give the sound greater dimension, with more fatness and breadth.

The settings of the chorus effect are memorized independently for each sound, and remain in effect until you turn off the power.

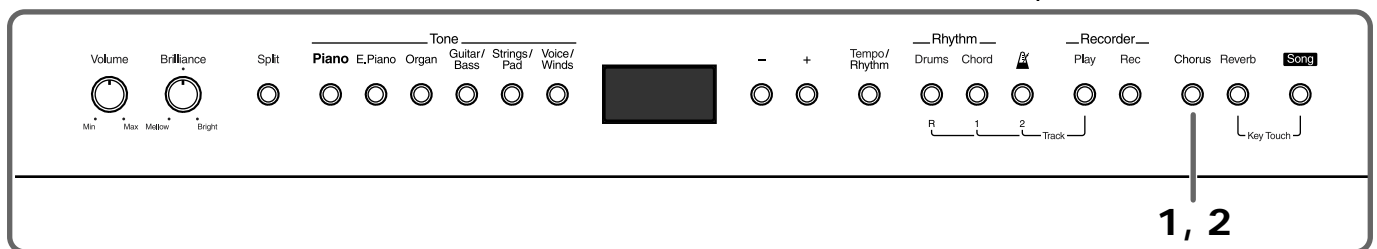

1, 2

1. Press the [Chorus] button, getting its indicator to light.

Try fingering the keyboard.

The chorus effect is applied to the currently selected tone.

2. To remove the chorus effect, press the [Chorus] button once more, extinguishing the indicator.

■ Adding a Spinning Sound to Organ Tones (Rotary Effect)

Some organ tones selected with the [Organ] button feature a rotary effect. When one of these tones is selected, you can use the [Chorus] button to change the speed of the rotary effect.

What the rotary effect does is to add a “spinning” effect similar to the sound of an organ using a rotating speaker.

Press the [Organ] button and select the organ tone.

Each time pressing the [Chorus] button, switch the speed of the rotary effect between rapid and slow rotation.

When a tone that has the Rotary effect added is selected, the [Chorus] button's indicator flashes in red or green.

When the [Chorus] button's indicator flashes in red, a more rapid rotary effect is applied.

When the [Chorus] button's indicator flashes in green, a slower rotary effect is applied.

■ Changing the Depth of Chorus Effect

You can select from ten levels of depth for the chorus effect.

1. Hold down the [Chorus] button and press the [-] or [+] button.

The [Chorus] button's indicator flashes in red.

The depth for the chorus effect being applied to the currently selected tone appears in the display.



Some tones initially have chorus applied. Selecting such a tone makes the [Chorus] button's indicator light up automatically.



For more information on Tones applied the Rotary effect, see “Tone List” (p. 48).



You cannot change the levels of depth for the rotary effect.



2. Press the [-] or [+] button to change the depth of effect.
3. Press the [Chorus] button once more.

The button's indicator returns to its previous state.

The next time you choose the same tone, the chorus effect with the depth you've selected here is applied.

Adding Reverberation to Sounds (The Reverb Effect)

You can apply a reverb effect to the notes you play on the keyboard. With the reverb effect, you obtain a pleasant reverberation, making it sound as if you were performing in a concert hall or similar space.

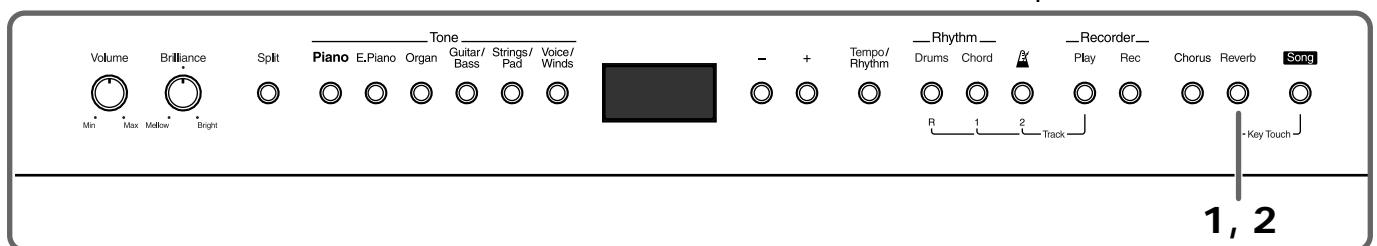

1. Press the [Reverb] button, getting its indicator to light.
Try fingering the keyboard.
The reverb effect is applied to the entire tone.
2. To eliminate the Reverb effect, press the [Reverb] button once more, extinguishing the indicator.

■ Changing the Depth of Reverb Effect

You can select from ten levels of depth for the reverb effect.

1. Hold down the [Reverb] button and press the [-] or [+] button.

The [Reverb] button's indicator flashes in red.

The selected depth for the reverb effect appears in the display.



2. Press the [-] or [+] button to change the depth of the effect.
3. Press the [Reverb] button once more.

The indicator returns to its previous state.

NOTE

You cannot make separate reverb effect depth settings for each individual tone. The effect is applied at the same depth to all tones.

Transposing the Key of the Keyboard (Key Transpose)

You can transpose the key of a performance without having to shift the position of your fingers on the keyboard. This feature is called “Key Transpose.”

This lets you take a song in a difficult key with lots of sharps (#) and flats (b) and play it in a key with fingering that’s easier for you. This is handy when playing accompaniment to a song, to match what you play to the pitch of the singer’s voice.

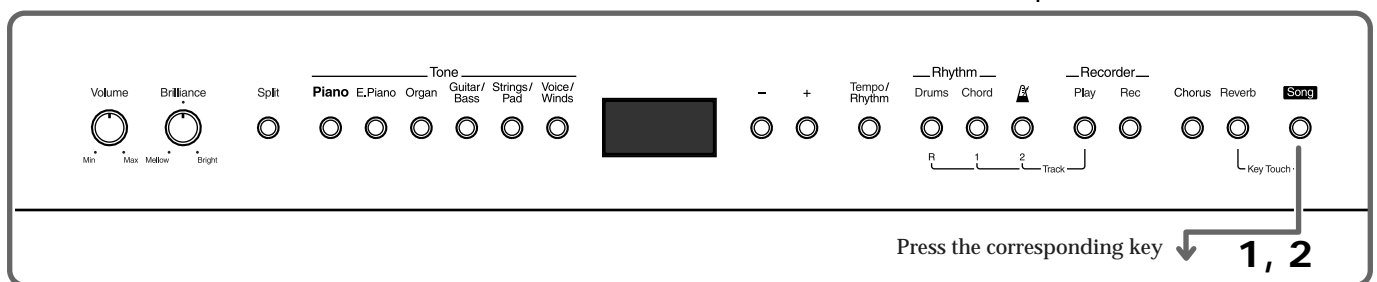

1. Hold down the [Song] button and press the key corresponding to the tonic of the desired key.

The Key Transpose settings value continues to appear in the display while the [Song] button is held down.

With the [Song] button held down, you can change the value, even by pressing the [-] or [+] button.

Additionally, by holding down the [Song] button and pressing the [-] or [+] button one time, you can display the currently selected Key Transpose value.

The available range is -6–0–5.



When you release the [Song] button, you return to the previous screen.

2. To return to the original key, hold down the [Song] button and press the C key (the tonic of C Major).

Example: Playing a Song in the Key of E Major After Transposition to C Major

Hold down the [Song] button and press the E key (since E is the tonic).

Counting from C as a reference point, one moves up four keys, including the black keys, to reach E, thus “4” appears in the display.



By holding down the [Song] button and pressing both the [-] and [+] buttons simultaneously, the setting returns to its original value.

Using the Metronome

Here's how you can make use of the metronome.

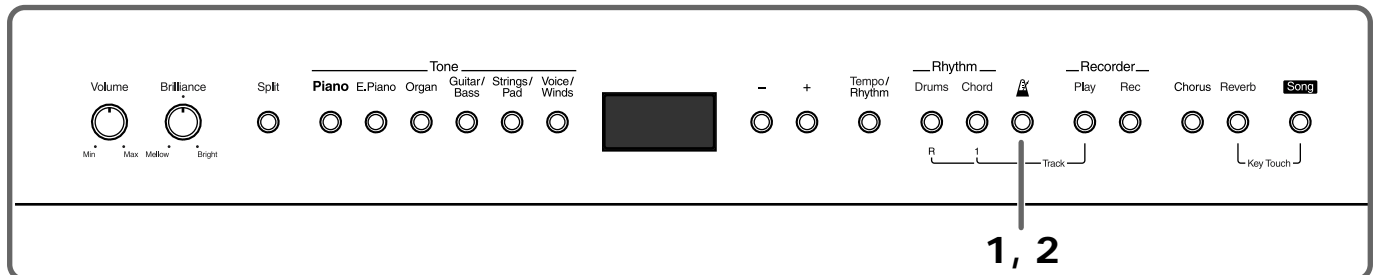

1. Press the [(Metronome)] button to have the metronome sound.

The [Tempo/Rhythm] button's indicator flashes in red and green in time with the beat selected at that time. The indicator lights in red on the downbeats, and in green on weak beats.

The tempo appears in the display.



2. To stop the metronome, press the [(Metronome)] button again.

■ Changing the Tempo

1. Press the [Tempo/Rhythm] button, so you have the tempo displayed.

Pressing the [Tempo/Rhythm] button alternately displays the tempo and the currently selected Rhythm number (indicated by an initial "r").

When the tempo is displayed, the [-] and [+] buttons light in red.

2. Press the [-] or [+] button to adjust the tempo.



About Rhythm, refer to "Chapter 2 Playing Along with Rhythms" (p. 25).

■ Changing the Beat of Metronome

1. **While holding down the [Tempo/Rhythm] button, press the [-] or [+] button.**

The [Tempo/Rhythm] button's indicator flashes in red.

The currently selected beat is displayed.

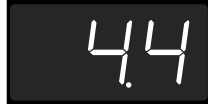

2. **Press the [-] or [+] button to select the beat.**

You can select from the following beats.

Display	Beat	Display	Beat
2.2	2/2	6.4	6/4
0.4	Weak beats only	7.4	7/4
2.4	2/4	3.8	3/8
3.4	3/4	6.8	6/8
4.4	4/4	9.8	9/8
5.4	5/4	12.8	12/8

3. **Press the [Tempo/Rhythm] button.**

The button's indicator returns to its previous state.

■ Changing the Volume

The volume of the metronome can be adjusted, with ten volume levels available.

This is set to "5" when the instrument is turned on.

1. **While holding down the [ (Metronome)] button, press the [-] or [+] button.**

The [ (Metronome)] button's indicator flashes in red.

The currently selected metronome volume is displayed.



2. **Press the [-] or [+] button to adjust the volume.**

3. **Press the [ (Metronome)] button.**

The button's indicator returns to its previous state.

NOTE

You cannot change the metronome beat while a song or Rhythm is being played.

Chapter 2 Playing Along with Rhythms

What is Session Partner?

“Session Partner” Lets You Enjoy Playing with a Session-Like Feel

“Session Partner” is a function that lets you select the On/Off status of the two Rhythm buttons along with the “Rhythm,” making it easy to add accompaniment.

You can play intros, endings, and fill-ins (short phrases inserted at transition points in the song) by pressing buttons as you play the keyboard.

Additionally, you can also have chord changes be made automatically as you play the Rhythm, giving you piano performances with a session-like feel—like having a whole band backing you.

What You Can Do With “Session Partner”

“Session Partner” lets you mainly do the following things.

- Play along to a Rhythm’s Drum Part in place of the metronome sound (p. 26)
- Play piano with a session-like feel along with Rhythms while the chord progression continues automatically (p. 26)
- Play the piano to provide your own accompaniment as you specify chords with the left hand (the left part of the keyboard) (p. 31)
- Record Rhythms along with specified chords, then use the entire keyboard to perform along with this prerecorded accompaniment (p. 35)

By changing the chords and Rhythms, even while playing the same melody, you can easily enjoy creating all kinds of new arrangements.

We encourage you to enjoy the variety of performance options open to you by using the “Session Partner” feature.

What are the FP-3’s “Rhythms?”

The FP-3 features internal “Rhythms” complementing Jazz, Rock, and other various musical genres.

“Rhythms,” which combine rhythmic patterns, bass patterns, and other elements found in different musical styles, form the foundation of performance accompaniment in the “Session Partner” function.

Additionally, each Rhythm is composed of a “Drum Part” and a “Chord Part.”

Drum Parts consist of drum sounds. Chord Parts are Parts in which chords are played, with the bass sound forming the foundation, but also using other instrumental sounds. You can play each of these Parts by pressing the [Drums] and [Chord] buttons.

Performing Along With Rhythms

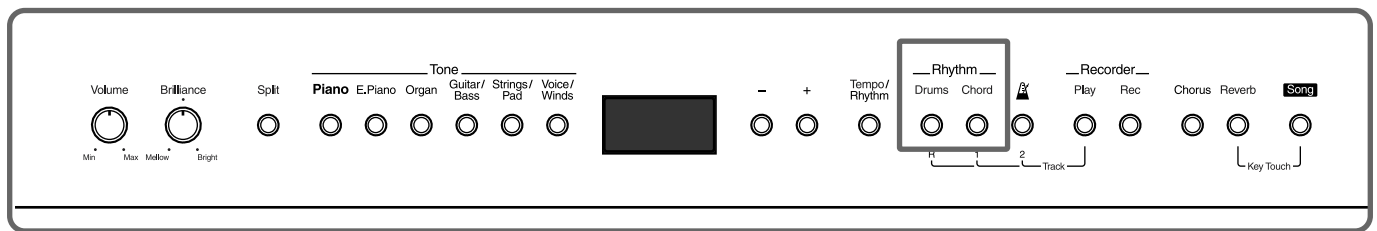

■ Performing Along With Drum Sounds

Now, try performing as the sound of the Rhythm's Drum Part plays.

Since a wide variety of musical genres is provided, be sure to use a Rhythm that best suits the song you are performing. Please refer to "Selecting a Rhythm" (p. 28).

1. Press the [Drums] button.

The [Drums] button's indicator lights up, and the intro begins to play.

2. When you press the [Drums] button once more, the ending is played, and the Rhythm stops.

The [Drums] button's indicator goes out.

■ Performing With Chord Parts

In addition to the Drum Parts, you can also perform with "Chord Parts" that use bass and other sounds.

The chord progression is automatic, so feel free to play the melody any way you like.

Furthermore, you can also stop the Chord Part during the performance and have only the Drum Part continue playing.

1. Press the [Chord] button.

The indicators for the [Chord] and [Drums] buttons light up, and the intro begins to play.

2. Press the [Chord] button, extinguishing the indicator.

The Chord Part sound stops, and only the Drum Part continues playing.

3. Press the [Chord] button again, getting the button's indicator to light.

The Chord Part sound starts playing again.

4. When you press the [Drums] button once more, the ending is played, and the Rhythm stops.

The lights for the [Chord] button and the [Drums] button go out.

NOTE

You cannot play the internal song and Rhythm at the same time.



For more information on the different Rhythm types, refer to the "Rhythm List" (p. 49).



To Immediately Stop a Rhythm

You can press the [Play] button to stop a Rhythm immediately. Additionally, when the [Drums] button indicator is lit in red, if you then press the [Drums] button once more, you can immediately stop the intro or ending, even when while these are being played.



You can change the chord progression patterns. Refer to the "Chord Progression Pattern List" (p. 50).



You can also specify the chords to be played in a Rhythm. For details, refer to "Performing With the Chord Progression Specified in the Left Hand (Rhythm Split Play)" (p. 31).

Playing Only the Bass Sound of the Chord Part

A Rhythm’s Chord Part not only contains its fundamental bass sound, but may also include the sound of instruments other than the bass. However, you can have just the bass sound of such Chord Parts play.

You can also change the settings while the Rhythm is being played.

This setting is effective for all Rhythms until the FP-3’s power is turned off.

1. Hold down the [Song] button and press the [Chord] button.

The indicators for the [Song] and [Chord] buttons flash in red.



2. Press the [-] or [+] button to select the setting.

Indication	Description
On	All of the Chord Part’s sounds are played.
OFF	Only the Chord Part’s bass sound is played.

3. Press the [Song] button.

The indicators return to their previous state.

About the lighting of the [Drums] and [Chord] button indicators

The indicators of the [Drums] and [Chord] buttons indicate the status of the Rhythm performance, as shown below.

Indicator	Performance
Dark ○	Performance is stopped
Lit in red ●	Intro/Fill-In/Ending is being played
Lit in green ●	Rhythm is being performed

Selecting a Rhythm

Now, try changing the Rhythm being performed.

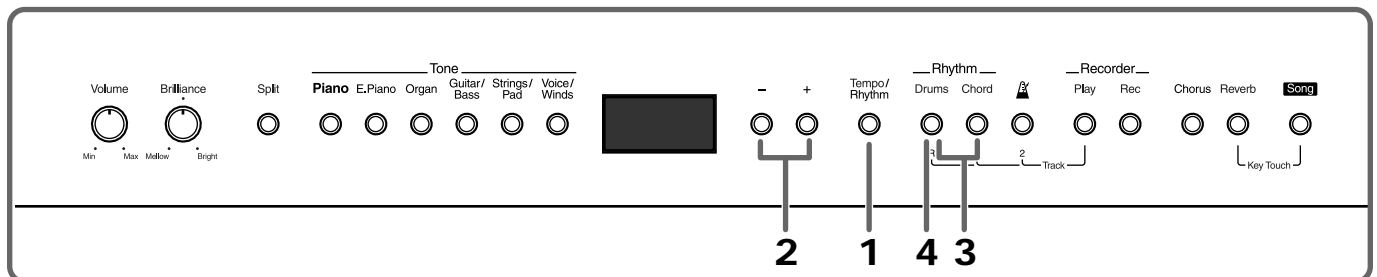

1. Press the [Tempo/Rhythm] button so that the Rhythm number appears in the display.

Rhythm numbers are indicated by an “r” before the number.

When a Rhythm is displayed, the [-] and [+] buttons light in green.

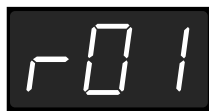

2. Press the [-] or [+] button to select the Rhythm.

3. Press the [Chord] or [Drums] button.

The button's indicator lights up, and the intro of the selected Rhythm begins to play.

4. To stop the performance, press the [Drums] button.

An Ending is played, then the Rhythm stops.

The indicator for the [Chord] or [Drums] button goes out.

■ Changing Rhythms As You Perform

If you change Rhythms while a Rhythm is being played, the selected Rhythm begins after the fill-in is played. The indicator for the [Chord] button or [Drums] button lights in red while the fill-in is played.

What's a “Fill In”?

A short improvisational phrase inserted at the bar line is called a “Fill In.”

The phrase best suited to the selected Rhythm is played.

NOTE

You cannot change Rhythms while the intro or ending is being played.

Changing a Rhythm's Tempo

You can change the tempo of the selected Rhythm.

Furthermore, you can change the tempo as the Rhythm is being played.

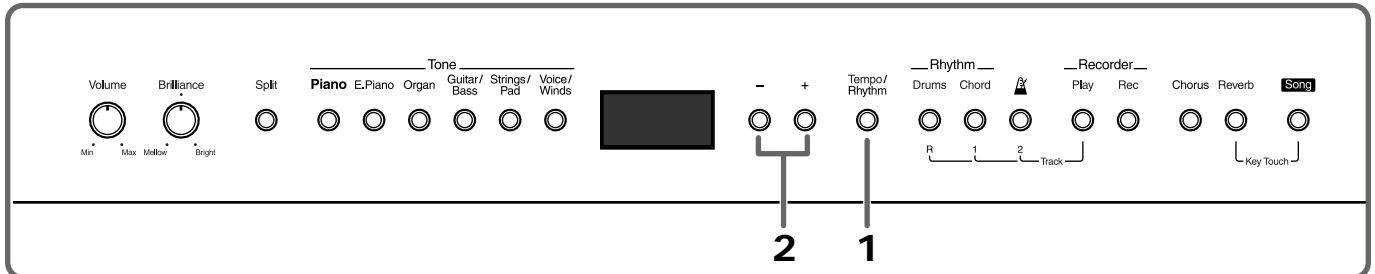

1. Press the [Tempo/Rhythm] button to have the tempo displayed.

Pressing the [Tempo/Rhythm] button alternately displays the tempo and the currently selected Rhythm number (indicated by an initial "r").

When the tempo is displayed, the [-] and [+] buttons light in red.

2. Press the [+] and [-] buttons to adjust the tempo.

The tempo can be changed within the range from ♩ = 20 ~ 250.

When the [Chord] button or [Drums] button is pressed, the Rhythm is played at the selected tempo.

Pressing both the [-] and [+] buttons simultaneously returns the tempo to ♩ = 96.

Selecting a Rhythm's Chord Progression

When playing the Chord Part while performing, the chord progression is automatic. You can change the chord progression pattern if you want.

These settings cannot be memorized independently for each Rhythm.

1. Hold down the [Chord] button and press the [-] or [+] button.

The [Chord] button's indicator flashes in red.

The currently selected chord progression pattern number and the root of the beginning chord are displayed.

The performance stops when the Rhythm is played.



Chord progression pattern number The root of the beginning chord

2. Press the [-] or [+] button to change the chord progression pattern.

3. Press the key corresponding to the root note of the first chord.

The chord progression that follows is changed to match the specified chord.

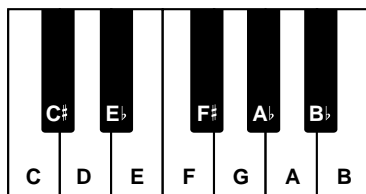

4. Press the [Chord] button once more.

The button's indicator returns to its previous state.



For more information on chord progression patterns, refer to the "Chord Progression Pattern List" (p. 50).



The root is indicated in the display as shown below.

Display	C	C ⁻	d	E ₋
Letter name	C	C [#]	D	E _b
Display	E	F	F ⁻	G
Letter name	E	F	F [#]	G
Display	A ₋	A	b ₋	b
Letter name	A _b	A	B _b	B



You can specify chords yourself in Split Play. For details, refer to "Performing With the Chord Progression Specified in the Left Hand (Rhythm Split Play)" (p. 31).

Performing With the Chord Progression Specified in the Left Hand (Rhythm Split Play)

Performing with the keyboard divided at a certain key into a left side and a right side is called “Split Play.”

When using the Rhythm while Split Play is in effect, you can specify the chords with the keys in the left part of the keyboard.

NOTE

When specifying the chords in the left part of the keyboard, Dual Play (p. 15) is disabled in the right part.

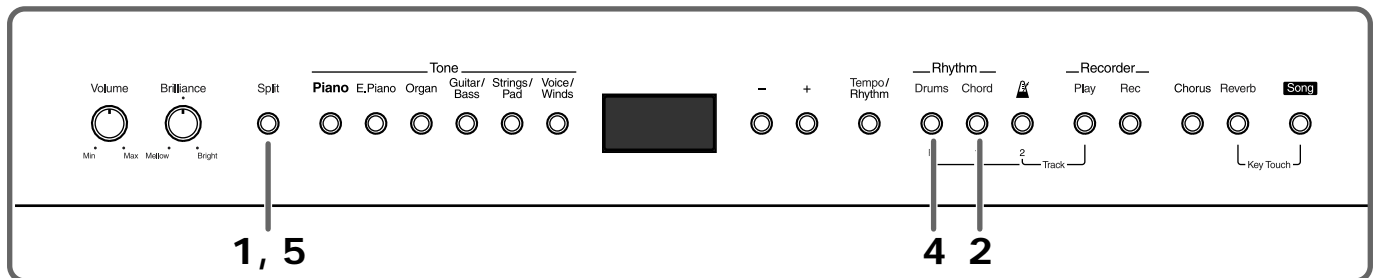

1. Press the [Split] button, getting its indicator to light.

2. Press the [Chord] button, getting its indicator to light.

The indicators for the [Chord] and [Drums] buttons flash, and the FP-3 is put into standby mode.

When the [Split] button is pressed while a performance is in progress, the Rhythm stops.

3. The chord is specified with a key in the left part of the keyboard, and the Rhythm begins.

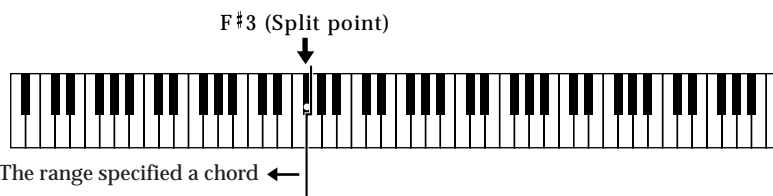

Specify the chord in the left part of the keyboard, and perform the melody in the right side.

It is not necessary to continue holding down the keys for chords in the left side. Even after you release the key, the same chord continues until the next chord is played.

When specifying chords, sounds from the left side of the keyboard are not played.

4. To stop the Rhythm, press the [Drums] button.

After the ending is done, the performance stops.

The indicators for the [Chord] and [Drums] buttons then start flashing, and the FP-3 is put into standby mode.

5. To exit Split Play, press the [Split] button, extinguishing the indicator.

MEMO

The point at which the keyboard is divided is called the “split point”; you can also change this split point. For more information, take a look at “Changing the Keyboard’s Split Point” (p. 17).

MEMO

You can specify chords simply with your finger, even without playing the keys for all the chords’ constituent notes. For more information about chord fingering, refer to the “Chord Fingering List” (p. 52).

MEMO

While in Split Play, when the [Chord] button is off, and only the Drum part is being played, you can perform in the left side of the keyboard using the Lower Tone (p. 16).

Changing the Volume Balance Between the Keyboard and the Rhythm

When using Rhythms in a performance, you can change the balance between the Rhythm volume and the volume of the performance played on the keyboard.

When the power is turned on, the volume balance is set to “5-5” (“Keyboard volume” – “Rhythm volume”).



When you change the volume balance between the keyboard and the Rhythm, the volume balance between the keyboard and the internal song may change.

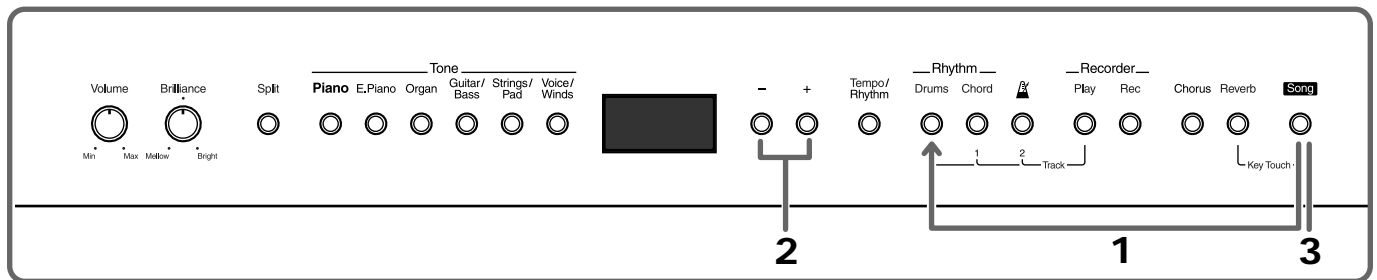

1. Hold down the [Song] button and press the [Drums] button.

The [Song] and [Drums] buttons' indicator flashes in red.

The selected volume balance appears in the display.



Keyboard volume Rhythm volume

2. Press the [-] or [+] button to adjust the volume balance.

To restore the normal default volume balance, press the [-] and [+] buttons simultaneously.

3. Press the [Song] button.

The buttons' indicator return to their previous state.

Chapter 3 Recording a Performance

You can easily record your performances.

You can play back a performance you have recorded to check what and how you played, and play melodies on the keyboard along with prerecorded accompaniment using the Rhythm.

Notes Regarding Recording

- Only one song can be recorded. With second or later recordings, the previously recorded song is erased as the new material is recorded. When recording a new performance, it is probably a good idea to erase the previously recorded performance first (p. 37).
- Recorded performances are erased when the power is turned off.

Recording a Performance

This records only what you play on the keyboard, without using the Rhythm.



To Record Without Erasing the Previously Recorded Performance...

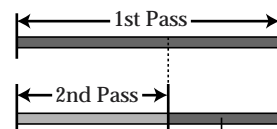

The first Performance is preserved

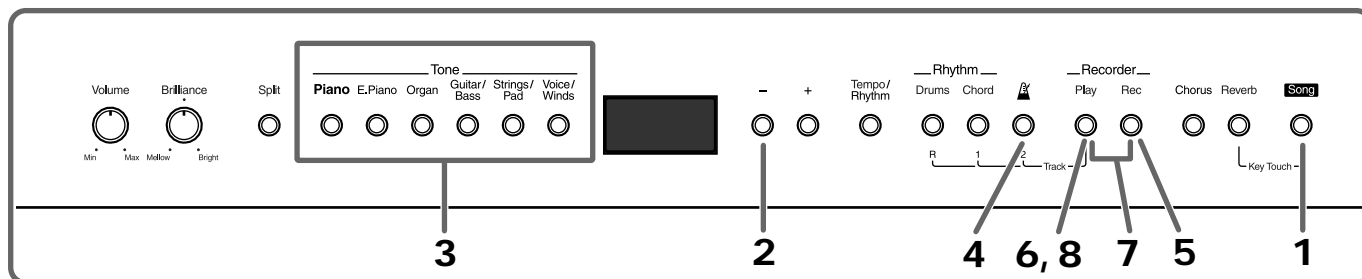

- 1. Press the [Song] button, getting its indicator to light.**
The song number appears in the display.
- 2. Press the [-] button to display the “USr.”**
- 3. Select the Tone to be played.**
- 4. If necessary, sound the metronome.**
While listening the metronome, select the tempo and beat of the song (p. 23).
- 5. Press the [Rec] button.**
The [Rec] button's indicator lights, the [Play] button's indicator begins flashing, and the FP-3 is put into recording standby.
- 6. Press the [Play] button or play a key on the keyboard to begin recording.**
Press the [Play] button, and after two measures of count sound, recording begins.
Recording will begin when you start playing the keyboard, even if you do not press the [Play] button. In this case, a count is not sounded.
- 7. Press the [Rec] button or the [Play] button to stop recording.**
The indicators for the [Rec] and [Play] buttons are extinguished, and recording stops.

Listening to the Recorded Performance

- 8. Press the [Play] button.**
Press the [Play] button again, and playback stops.

NOTE

When you record additional material without erasing the previously recorded sounds, the song is recorded at the initially recorded tempo.



During the count-in, the count measure is indicated in the display as “-2” then “-1.”



About “USr” in the Display

When recording is stopped, the “**USr**” indication changes to “**USr.**” in the display. The “.” in the display indicates that there is Performance material already recorded.

■ Recording a Performance Using Rhythms

You can also easily record session performances to the internal Rhythms and chord progressions.

NOTE

When you record additional material without erasing the previously recorded sounds, the song is recorded at the initially recorded tempo.

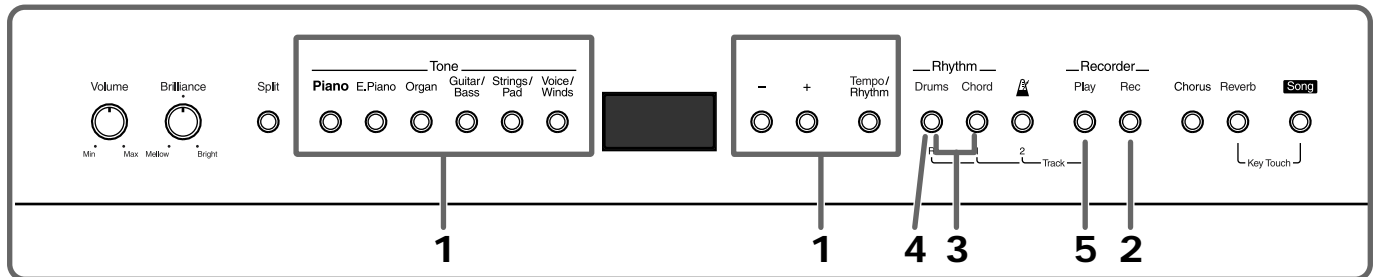

1. Select the Tone or Rhythm to be played.

Also set the Rhythm tempo to one that is easier to play (p. 29).

2. Press the [Rec] button.

The [Rec] button's indicator lights up, the [Play] button's indicator flashes, and the FP-3 is put into recording standby.

3. Press the [Chord] button or the [Drums] button to begin recording.

The Rhythm starts to play, while simultaneously recording begins.

4. Press the [Drums] button to stop recording.

The ending is played, and the performance and recording stop.

When you press the [Rec] button or the [Play] button, recording stops without the ending being played.

Listening to the Recorded Performance

5. Press the [Play] button.

Press the [Play] button again to stop playback.

MEMO

For more on selecting tone and Rhythm, refer to p. 14 and p. 28.

MEMO

For more information on the different Rhythm and Chord progression pattern, refer to the "Rhythm List" (p. 49) and "Chord Progression Pattern List" (p. 50).

NOTE

A Rhythm cannot be started while recording is in progress.

■ Recording Selected Track buttons

FP-3's Recorder has three Track buttons.

When you press the [Rec] button, all Track buttons are set to be recorded, but by selecting Track buttons that are not to be recorded, you can then record only on the specific Track buttons you want.

For example, you can record each hand's performance to different Track buttons, or record over only certain Track buttons in a previously recorded performance.

Only sounds from Drum set tones and Rhythm sounds can be recorded to the [Drums (R)] button.

NOTE

When you record additional material without erasing the previously recorded sounds, the song is recorded at the initially recorded tempo.

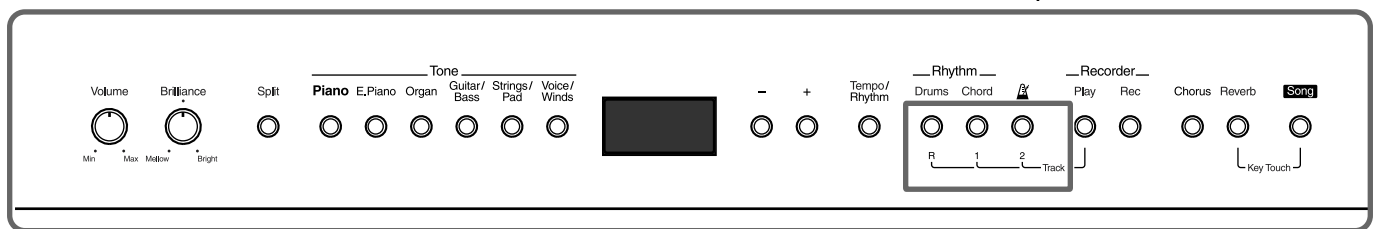

1. While holding down the [Rec] button, and turn off the indicator light for the Track button, whether the [Drums (R)], [Chord (1)], or [ (2)] button, for any track not to be recorded.

The [Rec] button's indicator lights up, the [Play] button's indicator flashes, and the FP-3 is put into recording standby.

With the FP-3 in standby, go on to record the performance according to the procedures as described in "Recording a Performance" (p. 33), "Recording a Performance Using Rhythms" (p. 34) or "Recording a Performance Using Rhythms (in Split Play)" (p. 35), starting from Step 3.

The performance is recorded only to the Track buttons whose indicator was lit.

Recording along with internal songs

You can also record your own performance as you play along with the internal piano songs.

When recording to specific Track buttons, the sounds on the selected Track buttons are not played. For example, you can record what you are playing with your right hand as you listen to the left-hand part.

1. With the [Song], [-] and [+] buttons select the song.
2. Hold down the [Rec] button and light the indicator for the track button of the track you intend to play yourself.

The [Rec] button's indicator lights up, the [Play] button's indicator flashes, and the FP-3 is put into recording standby.



3. Press the [Play] button to start recording.

The material at the Track button whose indicator was lit in Step 2 is not played.

4. Press the [Rec] or [Play] button to stop recording.

MEMO

About the Lighting of Track Button Indicators when the [Rec] Button Is Pressed

Dark 	Not Recording
Lit in orange 	Recording Data Recorded
Lit in red 	Recording No Data Recorded

MEMO

Correspondence Between Internal Piano Song Track Buttons and Performance

[1] button: left-hand Part
[2] button: right-hand Part
No performance data is assigned to the [R] button.

NOTE

When recording along with an internal song, you will not be able to obtain playback at a modified tempo.

Erasing Recorded Performances

You can erase recorded performances.

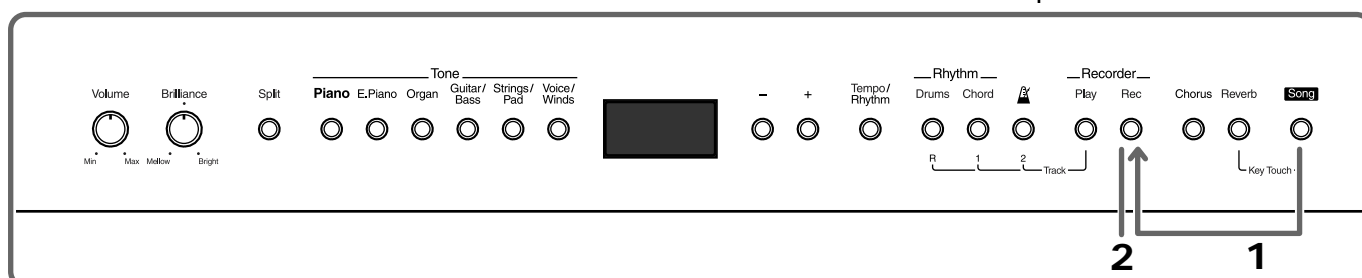

1. Hold down the [Song] button and press the [Rec] button.

A confirmation message appears in the display.

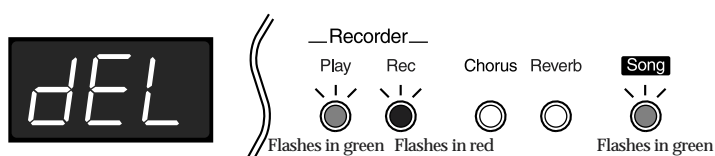

2. Press the [Rec] button.

The recorded performance is erased.

If you do not want to erase the performance, press the [Play] or [Song] button.

Correspondence Between Recorded Performance and Track Buttons

A recorded performance will be assigned to the Track buttons as follows.

Track button	Performance recorded
[R]	<ul style="list-style-type: none"> • Rhythm (Drums Part, Chord Part) (p. 25) • A performance of drum set tones
[1]	<ul style="list-style-type: none"> • Lower Tone in Dual play or Split play (p. 15, p. 16)
[2]	<ul style="list-style-type: none"> • The performance of the entire keyboard (except drum set tones) • Upper Tone in Dual play or Split play (p. 15, p. 16)

* You can also record to the [1] button regular keyboard performances in which only the [1] button is specified.

Chapter 4 Other Functions

Changing the Damper Pedal's Resonance

On an acoustic piano, depressing the damper pedal makes the notes you play resonate with other strings, adding rich reverberations and fatness to the sound. The damper pedal on the FP-3 recreates this resonance (Sympathetic Resonance) when depressed.

You can select from ten levels of depth for the resonant sound (resonance level).

This is set to "5" when the instrument is turned on.

* *This setting is effective only with tones 1, 2 and 5 for the [Piano] button. You cannot make this setting with other tones.*

1. Hold down the [Reverb] and [Chorus] buttons and press the [-] or [+] button.

The indicators for the [Reverb] and [Chorus] buttons flash in red.

The resonance for the currently selected tone appears in the display.



2. Press the [-] or [+] button to select the resonance level.

3. Press the [Reverb] or [Chorus] button.

The indicators return to their previous state.

Changing How the Pedals Work

Although a pedal connected to the Pedal [Soft] jack normally functions as a soft pedal (p. 10), it can also be set to function as a sostenuto pedal or expression pedal.

For use as a sostenuto pedal, connect the supplied pedal or a separately available pedal. For use as an expression pedal, connect the separately available expression pedal (EV-5).

When the instrument is turned on, this is set to function as a soft pedal.

1. Hold down the [Song] button and press the [E.Piano] button.

The indicators for the [Song] and [E.Piano] buttons flash in red.



2. Press the [-] or [+] button to select the pedal function.

Indication	Description
1 (Soft Pedal)	Sets function to soft pedal. Setting made when the instrument is turned on.
2 (Sostenuto Pedal)	When the pedal is pressed, only the sounds of the keys being pressed are sustained. Connect the supplied pedal or a separately available pedal.
3 (Expression Pedal)	Allows control of the volume. You can also change the volume with the [Volume] knob, but by using this pedal you can change the volume level without taking your hands off the keyboard. Connect a separately available expression pedal (EV-5).
4 (Start/Stop)	You can control the start/stop of Rhythms by pressing the pedal, instead of pressing the buttons. If you press the pedal when the Rhythm is stopped, the Rhythm begins from the intro (the same result as the [Chord] button being pressed). If you press the pedal when the Rhythm is playing, the ending is played and the Rhythm stops (the same result as the [Drums] button being pressed). You cannot start only the Drum Part, or stop only the Chord Part by pressing the pedal. (See p. 26.)

3. Press the [Song] button.

The indicators return to their previous state.

- * *Use only the specified expression pedal (EV-5; sold separately). By connecting any other expression pedal, you risk causing malfunction and/or damage to the unit.*
- * *Be sure to switch off the power to the unit before attempting to disconnect or connect a pedal cord.*

Changing How the Pedal Effects Are Applied

When the pedal is pressed in Dual Play (p. 15) or Split Play (p. 16), the pedal's effect is applied to both the Upper Tone and the Lower Tone, but you can change the settings for the tone to which the effect is applied.

When the instrument is turned on, the setting determining how the effects are applied is the same for both the Upper Tone and the Lower Tone ("1" in the table below).

1. Hold down the [Song] button and press the [Organ] button.

The indicators for the [Song] and [Organ] buttons flash in red.



2. Press the [-] or [+] button to select how the pedal effects are to be applied.

Indication	Description	Lower Tone	Upper Tone	Pedal
1	All enabled	○	○	Right Pedal
		○	○	Left Pedal
2	Applied only to the Upper Tone	x	○	Right Pedal
		x	○	Left Pedal
3	Left pedal enabled for Lower Tone only	○	○	Right Pedal
		○	x	Left Pedal

* Right pedal—connect to the [Damper] jack

* Left pedal—connect to the [Soft] jack

3. Press the [Song] button.

The indicators return to their previous state.

Changing the Pitch of the Lower Tone in Octave Steps (Octave Shift)

You can change the pitch of the Lower Tone in Dual Play (p. 15) and Split Play (p. 16) an octave at a time.

Altering the pitch in one-octave units in this way is called "Octave Shift."

For example, you can raise the pitch of the Lower Tone to the same pitch of the Upper Tone in Split Play.

The range of available pitch change spans from two octaves higher to two octaves lower.

This setting remains in effect until you turn off the power.

1. Hold down the [Song] button and press the [Piano] button.

The indicators for the [Song] and [Piano] buttons flash in red.



2. Press the [-] or [+] button to select the pitch.

The pitch is lowered one octave each time the [-] button is pressed, while each press of the [+] button raises the pitch by one octave.

To return to the original pitch, press the [-] and [+] buttons simultaneously.

3. Press the [Song] button.

The indicators return to their previous state.

Tuning to Other Instruments' Pitches (Master Tuning)

When playing ensemble with other instruments and in other such instances, you can match the standard pitch to another instrument.

The standard pitch generally refers to the pitch of the note that's played when you finger the middle A key. For a cleaner ensemble sound while performing with one or more other instruments, ensure that each instrument's basic pitch is in tune with that of the other instruments. This tuning of all the instruments to a standard pitch is called "master tuning."

You can set the standard pitch anywhere in a range of 415.3 Hz to 466.2 Hz.

When the instrument is turned on, the standard pitch is set to "440.0 Hz."

This setting remains in effect until you turn off the power.

1. Hold down the [Song] button and press the [Voice/Winds] button.

The indicators for the [Song] and [Voice/Winds] buttons flash in red.



The last three digits of the current standard pitch setting appear in the display.

2. Press the [-] or [+] button to change the standard pitch.

The pitch is lowered 0.1 Hz each time the [-] button is pressed. When the button is held down, the pitch drops continuously.

The pitch is raised 0.1 Hz each time the [+] button is pressed. When the button is held down, the pitch rises continuously.

To return to the original pitch, press the [-] and [+] buttons simultaneously.

3. Press the [Song] button.

The indicators return to their previous state.

Adjusting the Tuning

You can play classical music such as baroque pieces using their original tuning.

Most modern songs are composed and played with the assumption that equal temperament (the most common tuning in use today) will be used, but when classical music was composed, there were a wide variety of other tuning systems in existence. Playing a composition with its original tuning lets you enjoy the sonorities of the chords that the composer originally intended.

1. Hold down the [Song] button and press the [Chorus] button.

The indicators for the [Song] and [Chorus] buttons flash in red.

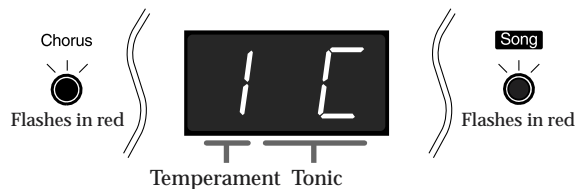

2. Press the [-] or [+] button to change the temperament, and press the key corresponding to the keynote.

You can choose from among the seven tunings described below.

	Temperament	Qualities
1	Equal	In this tuning, each octave is divided into twelve equal steps. Every interval produces about the same amount of slight dissonance. This setting is in effect when you turn on the power.
2	Pythagorean	This tuning, devised by the philosopher Pythagoras, eliminates dissonance in fourths and fifths. Dissonance is produced by third-interval chords, but melodies are euphonious.
3	Just Major	This tuning eliminates ambiguities in the fifths and thirds. It is unsuited to playing melodies and cannot be transposed, but is capable of beautiful sonorities.

	Temperament	Qualities
4	Just Minor	The Just tunings differ from major and minor keys. You can get the same effect with the minor scale as with the major scale.
5	Mean Tone	This scale makes some compromises in just intonation, enabling transposition to other keys.
6	Werckmeister	This temperament combines the Mean Tone and Pythagorean tunings. Performances are possible in all keys (first technique, III).
7	Kirnberger	This is an improvement of the Mean Tone and Just tunings that provides a high degree of freedom of modulation. Performances are possible in all keys (III).

The display is as follows:

Display	C	d _˘	d	E _˘	E	F	F _˘	G	A _˘	A	b _˘	b
Letter name	C	D ^b	D	E ^b	E	F	F [#]	G	A ^b	A	B ^b	B

When playing with tuning other than equal temperament, you need to specify the keynote for tuning the song to be performed (that is, the note that corresponds to C for a major key or to A for a minor key).

If you choose an equal temperament, there's no need to select a keynote.

3. Press the [Song] button.

The indicators buttons return to their original state.

* *When performing in ensemble with other instruments, be aware that depending on the key, there may be some shifting of the pitch. Tune the FP-3 to the fundamental pitch of the other instruments.*

Changing the Beat Pattern





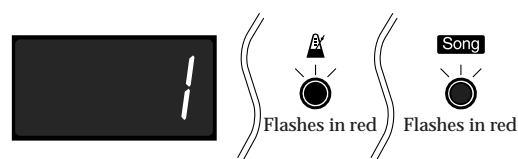

The metronome usually sounds one beat per quarter note, but you can change the beat pattern to sound, for example, one beat for every dotted quarter note.

1. Hold down the [Song] button and press the [(Metronome)] button.

The indicators for the [Song] and [ (Metronome)] buttons flash in red.



2. Press the [-] or [+] button to change the beat division.

Indication	Description
— (Normal)	The metronome sounds in the ordinary way.
A1	The metronome plays with a backbeat added to each beat.
A2	Counting is with triplets for each beat.
A3	The added sounds are shuffled.
2. ()	Counting starts at the beginning of the measure, in intervals of dotted half-note upbeats.
2 ()	Counting starts at the beginning of the measure, in intervals of half-note upbeats.
4. ()	Counting starts at the beginning of the measure, in intervals of dotted quarter-note upbeats.
4 ()	Counting starts at the beginning of the measure, in intervals of quarter-note upbeats.
8. ()	Counting starts at the beginning of the measure, in intervals of dotted eighth-note upbeats.
8 ()	Counting starts at the beginning of the measure, in intervals of eighth-note upbeats.
16 ()	Counting starts at the beginning of the measure, in intervals of sixteenth-note upbeats.

3. Press the [Song] button.

The indicators return to their previous state.

→ *If you select "A1" with a triplet rhythm (6/8, 9/8, 12/8), the additional sound is played in the same way as "A2."*

→ *Refer to "Using the Metronome" (p. 23).*

Connecting MIDI Devices

About MIDI

MIDI stands for “Musical Instrument Digital Interface,” and is a worldwide standard for the exchange of performance data (MIDI messages) and other information among electronic instruments and computers.

The FP-3 features a MIDI connector and a computer connector to allow performance information to be exchanged with external devices. Connecting the keyboard to other devices with these connectors provides you with an even greater variety of ways to use your keyboard.

* *A separate publication titled “MIDI Implementation” is also available. It provides complete details concerning the way MIDI has been implemented on this unit. If you should require this publication (such as when you intend to carry out byte-level programming), please contact the nearest Roland Service Center or authorized Roland distributor.*

Connectors

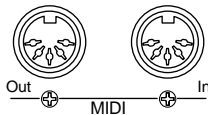

MIDI Out Connector

Sends data about what is being played on the keyboard and other performance data.

Connect to the MIDI in connector on the external MIDI device.

MIDI In connector

Receives messages sent from external MIDI devices.

Connect to the MIDI Out connector on the external MIDI device.

Making the Connections

* *To prevent malfunction and/or damage to speakers or other devices, always turn down the volume, and turn off the power on all devices before making any connections.*

1. Turn the volume all the way down on the FP-3 and on the device you're about to connect.
2. Turn off the power to the FP-3 and to the device being connected.
3. Connect a MIDI cable (sold separately) between the MIDI connectors on each device.
4. Switch on the power to the FP-3 and the connected device.
5. Adjust the volume level on the FP-3 and the connected device.
6. You should also set the MIDI settings as needed. Make the settings for the MIDI send and receive channels (p. 43) and for Local On/Off (p. 43).

How to Enjoy MIDI

Recording Data of Performances Played on the FP-3 to a Sequencer* and Automatically Playing Recorded Performance Data on the FP-3

Connection example:

Connecting to a sequencer (the Roland MT series, etc.)

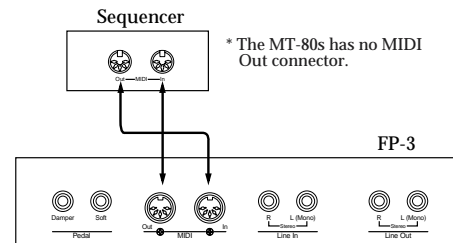

→ When connecting a sequencer, we recommend using it with the settings described below.

- Local Control off (p. 43)
- MIDI Out Mode 1 (p. 44)

When the instrument is turned on, MIDI Out Mode is set to “1.”

Performing on the FP-3 Using Sounds from Another Sound Module*

Connection Example: Connecting to a MIDI Sound Module

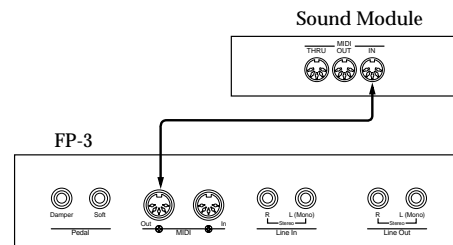

→ When connecting to a MIDI sound module, we recommend using the system with MIDI Out Mode set to “2” (p. 44). When the instrument is turned on, MIDI Out Mode is set to “1.”

What is a Sequencer?

A sequencer is a device that records the stream of MIDI messages that is sent out by an instrument. These messages convey all the details of what has occurred while the instrument is played; including the timing of notes, their sound, the force used to play them, and for how long. Afterwards, you can send the recorded MIDI information back to the instrument, and it will play automatically.

What is a MIDI Sound Module?

Inside a synthesizer or electronic piano is the section that actually produces sound, known as the sound module. A MIDI sound module produces sounds as the result of MIDI messages sent to it by other devices.

MIDI Settings

MIDI Send Channel Settings

MIDI features sixteen MIDI channels, numbered 1–16. Simply connecting a cable is not enough for communication to take place. The connected devices must be set to use the same MIDI channels. Otherwise, no sound will be produced, and no sounds can be selected. Select the transmission channel (1–16) of the FP-3. When the instrument is turned on, this is set to Channel “1.” The FP-3 receives messages on all channels, 1–16.

- * When the keyboard is split into left and right sides, the transmission channel for messages from the left-hand side is fixed at “3.”
- * When a Drum Set Tone is assigned to the keyboard, the transmission channel is fixed at “10.”

1. Hold down the [Song] button and press the [Guitar/Bass] button.

The indicators for the [Song] and [Guitar/Bass] buttons flash in red.



2. Press the [-] or [+] button to select the transmission channel.

3. Press the [Song] button.

The indicators return to their previous state.

Switching Local Control On and Off

When connecting a MIDI sequencer, set Local Control to “Off.”

When the instrument is turned on, this is set to “On.”

As illustrated, information describing what has been played on the keyboard is passed to the internal sound generator over two different routes, (1) and (2). As a result, you hear overlapping or intermittent sounds. To prevent this from happening, route (1) must be severed, by setting the unit to what is known as “Local Off.”

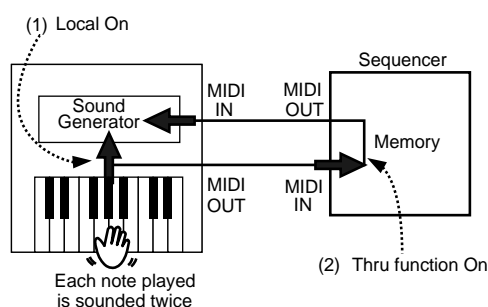

Local Control ON: The keyboard and the internal sound generator are in a linked state.

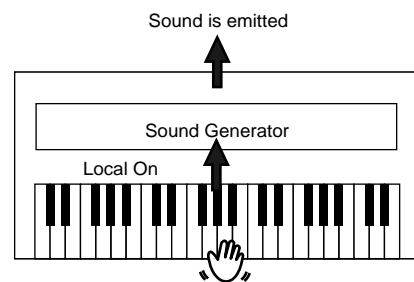

Local Control OFF: The keyboard and the internal sound generator are in an unlinked state. No sound will be produced by the keyboard when it is played.

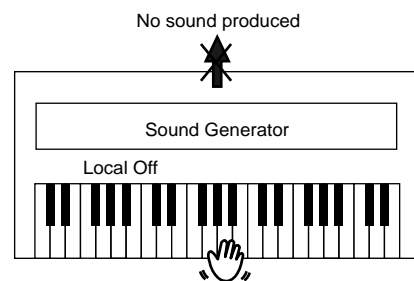

- * When connecting a unit in the Roland MT series, you don't need to switch off Local Control. MT units transmit Local Off messages when their power is switched on. If you first switch on the FP-3, then the MT-series device, Local Control is automatically switched off on the FP-3.

1. Hold down the [Song] button and press the [Tempo/Rhythm] button.

The indicators for the [Song] and [Tempo/Rhythm] buttons flash in red.

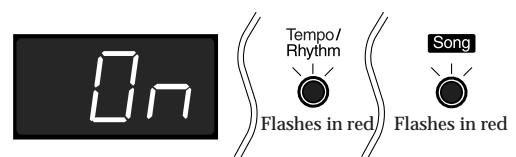

2. Press the [-] or [+] button to switch Local Control on and off.

3. Press the [Song] button.

The indicators return to their previous state.

Chapter 4 Other Functions

Setting the MIDI Out Mode

By setting the MIDI Out Mode, you can select to have a more suitable (to the external MIDI device) selection of MIDI data be output from the MIDI Out connector when you make tone changes on the FP-3.

Three settings for the MIDI Out Mode are available.

“MIDI Out Mode 1” is the power-up default setting.

	MIDI Out Mode	Descriptions
1	MIDI Out Mode 1	This setting is suitable for the connection of sequencers. The MIDI information shown below is output from the MIDI Out connector when you make a tone change on the FP-3. When recording something on a sequencer, this mode should assure that when you play back the performance on the FP-3, you will hear the same tones used when the performance was recorded. <ul style="list-style-type: none">• Program Change• Reverb or chorus effect on/off• Reverb or chorus effect depth• Sympathetic resonance depth
2	MIDI Out Mode 2	This setting is suited for connecting to a sound module. The MIDI information on tone and effect is not output from the MIDI Out connector when you make a tone change on the FP-3.
3	MIDI Out Mode 3	You can transmit performance data recorded with the FP-3. Additionally, the MIDI messages that are output have the same content as those in MIDI Out Mode 1.

3. Press the [Song] button.

The indicators return to their previous state.

1. Hold down the [Song] button and press the [Strings/Pad] button.

The indicators for the [Song] and [Strings/Pad] buttons flash in red.



2. Press the [-] or [+] button to select the MIDI Out Mode.

Troubleshooting

If you think there's a problem, read this first.

Case	Cause/What to do
No Power	Is the power cord properly connected? (p. 8)
No Sound	Is the volume level of the FP-3 (p. 11) or connected device turned all the way down?
No Sound (With a MIDI Device Connected)	Is the power to all devices turned on? (p. 10)
	Is the MIDI cable connected and plugged in correctly? (p. 42)
	Does the MIDI channel match the connected instrument? (p. 43)
No Sound, Even When Key is Pressed	Is Local Off selected? When Local Control is set to OFF, no sound is produced by playing the keyboard. Set Local Control to "ON" (p. 43).
The Volume of the Keyboard is Too Low	Is the volume balance for the keyboard turned all the way down? (p. 32)
No Sound From the Left Side	Is the [Split] button's indicator on? (p. 31) No sound from the left side is produced if the [Split] button's indicator is on while the Chord part is playing.
Two Sounds are Produced When the Keyboard is Played	Is the FP-3 in Dual Play? (p. 15)
	When the FP-3 is connected to an external sequencer, set it to the Local OFF mode (p. 43). Alternatively, set SOFT THRU on the sequencer to "OFF."
Not All Sounds Are Played	The FP-3 has a maximum polyphony of 64 voices. When playing together with a song or Rhythm along with heavy use of the damper pedal, the performance data may exceed the number of available voices, and as a result, some notes or sounds played on the keyboard may not sound.
The Keyboard or Song Register or Pitch is Off	Have you set Transpose? (p. 22)
	Are the settings for the Temperament (p. 40) correct?
	Is the setting for Master Tuning correct? (p. 40)
Rhythm Does Not Sound	Is the volume balance for the Rhythm turned all the way down? (p. 32)
Chords Not Recognized in the Left Side When Playing Rhythms	Is the [Split] button's indicator off (p. 31) When the [Split] button's indicator is off while the Chord part is playing, the chord progression then proceeds automatically.

Case	Cause/What to do
Song Doesn't Play Back	Is the [Song] button indicator lit in green? (p. 12) Songs cannot be played back when the [Song] button's indicator is on. Press the [Song] button, getting its indicator to light.
	Does "dEL" appear in the display? (p. 13) The internal songs cannot be played back while recorded performance data remains in the FP-3's memory. Try playing back the song after deleting the performance data.
The Volume of Internal Song is Too Low	Is the volume balance for the Rhythm (and internal song) turned all the way down? (p. 32)
Only the Sound of a Particular Instrument in a Song Does Not Play	Is Track Mute on? (p. 13) If the button's light is out when you hold down the [Play] button, the music on that track is not heard. Press the track button so the light is illuminated.
Cannot Select Tone or Rhythm	Is the [Song] button indicator flashing in red? When the [Song] button indicator flashes in red it means that setting of functions is in progress. Press the [Song] button once more, then select the tone or Rhythm.
Cannot Record	Have you selected which of the Track Buttons to be recorded? (p. 36)
Tempo of Recorded Song or Metronome is Off	When you select for recording an internal song that features tempo changes, the tempos of Performances recorded on other tracks are altered along with these changes. In addition, the Metronome tempo is also changed the same way.
	When you record additional material without erasing the previously recorded sounds, the song is recorded at the initially recorded tempo. (p. 37)
Recorded Performance is Erased	Performances that have been recorded are erased when the power for the FP-3 is turned off or when a song is selected. Once erased, Performances cannot be recovered.

Troubleshooting

Case	Cause/What to do
Pedal Has No Effect, or Effect "Sticks"	<p>Is the pedal connected correctly? Connect the pedal securely to the Pedal jack (p. 10).</p> <p>Unplugging a pedal cord from the unit while the power is on may cause the pedal's effect to be applied nonstop. Be sure to switch off the power to the unit before attempting to disconnect or connect a pedal cord (p. 10).</p>
Reverb Remains Even After Reverb is Lifted	As the FP-3 piano sounds faithfully reproduce the depth and reverberation of actual acoustic pianos, reverberation may still be audible even after the reverb effect is removed from sounds.
Sound Suddenly Changes at Key in Upper Octaves	With the acoustic piano settings, sounds in the upper 1 1/2-octave range are extended to the end regardless of the damper pedal actions. The tone is also different in this range. Roland's pianos faithfully reproduce the sonic qualities of acoustic pianos. Furthermore, you can use the instrument's Key Transpose setting to change that range over which the damper pedal has no effect.
High-Pitched Whine is Produced	<p>When listening through headphones: Certain piano tones that feature vibrant, sparking sounds contain a large high-frequency component, which may make it appear that a metallic reverberation has been applied. This faithfully reproduces the characteristics of acoustic pianos, and does not indicate any malfunction. Since this reverberation becomes particularly audible when supplemented by heavy reverb, you may be able to diminish the problem by reducing the amount of reverb applied to the sound.</p> <p>When listening through speakers: Here, a different cause (such as resonance produced by the FP-3) would be suspect. Consult your Roland dealer or nearest Roland Service Center.</p>

Case	Cause/What to do
Low End Sounds Are Strange/Have a Rattling Sound	<p>When listening through speakers: Playing at loud volumes may cause instruments near the FP-3 to resonate. Resonance can also occur with fluorescent light tubes, glass doors, and other objects. In particular, this problem occurs more easily when the bass component is increased, and when the sound is played at higher volumes. Use the following measures to suppress such resonance.</p> <ul style="list-style-type: none"> - Place speakers so they are 10–15 cm from walls and other surfaces. - Reduce the volume. - Move the speakers away from any resonating objects. <p>When listening through headphones: The cause lies somewhere else. Consult your Roland dealer or nearest Roland Service Center.</p>
The Volume Level of the Instrument Connected to Line In Jack is Too Low.	<p>Could you be using a connection cable that contains a resistor? Use a connection cable that does not contain a resistor.</p>

Error Messages/Other Messages

Display	Meaning
USr	User. Stores recorded Performances. (p. 12, p. 33)
Usr.	The "." in the display indicates that there is Performance material already recorded. (p. 12, p. 33)
d.	Demo song number. (p. 12, p. 36)
P.	Piano song number. (p. 12, p. 36)
r.	Rhythm number. (p. 28)
dEL	This appears when you attempt to delete a recorded song (p. 37). Additionally, this appears after recording a song when you try to select another song (p. 13).
E.32	The amount of performance information is too large, and further recording is not possible.
E.40	Too much MIDI data was sent from the external MIDI instrument at one time, and the unit could not process the data. Reduce the amount of MIDI data being sent to the FP-3.
E.41	A problem such as a loose MIDI cable or computer cable occurred. Make sure the MIDI cables and computer cables are correctly hooked up.
E.51	A system error has occurred. Try performing the procedure over again. Should this message continue to appear even after repeated attempts, please consult the nearest Roland Service Center.

* *Error messages are indicated by an "E." before the number*
When the Error message appears, the [-] and [+] button indicators flashes in red.
Press the [-] or [+] button, and you can cancel the error message.

Tone List

→ “Performing with a Variety of Sounds” (p. 14)

Piano

- 1 Grand Piano 1*
- 2 Grand Piano 2*
- 3 Rock Piano
- 4 Honky-tonk
- 5 Upright Piano*
- 6 Harpsichord

* indicates a tone with sympathetic resonance (p. 38).

E.Piano

- 1 Stage Rhodes
- 2 Dyno Rhodes
- 3 E.Piano
- 4 Suitcase
- 5 Wurly
- 6 Clavi
- 7 Vibraphone
- 8 Vibra Bell

Organ

- 1 Jazz Organ*
- 2 Rock Organ
- 3 Full Organ*
- 4 Lower Organ*
- 5 Church Organ
- 6 Nason Flute 8'

* indicates a tone with rotary effect (p. 20).

Guitar/Bass

- 1 Acoustic Guitar
- 2 Jazz Guitar
- 3 Acoustic Bass
- 4 Acoustic Bass + Cymbal
- 5 Fingered Bass
- 6 Thum Voice

Strings/Pad

- 1 Slow Strings
- 2 Strings
- 3 Warm JP Strings
- 4 Holy Voice
- 5 Sugar Key
- 6 Harp

Voice/Winds

- 1 Jazz Scat
- 2 Rich Choir
- 3 Dreamy Choir
- 4 Alto Sax
- 5 Flute
- 6 Trumpet
- 7 Pop Drum Set
- 8 Vox Drum Set

	Pop Drum Set	Vox Drum Set
21	R&B Snare	R&B Snare
22	Rock Snare	Rock Snare
23	Rock Snare	Rock Snare
24	Pop Snare m	Pop Snare m
25	Pop Snare Ghost	Pop Snare Ghost
26	Pop Snare m	Pop Snare m
27	Finger Snap	Finger Snap
28	707 Claps	707 Claps
29	Hand Clap [EXC7]	Hand Clap [EXC7]
30	Hand Clap2 [EXC7]	Hand Clap2 [EXC7]
31	Hand Clap	Hand Clap
32	Pop Pedal HH [EXC1]	Pop Pedal HH
33	Hand Clap	Hand Clap
34	Pop Snare Ghost	Vox Dut
35	Pop Kick	Vox Dom
C2 36	Pop Kick	Vox Tuush
37	Pop Side Stick	Vox Hehho
38	Pop Sanre s	Vox Doyear
39	Pop Snare Ghost	Vox Thu!
40	Pop Snare s	Vox That
41	Pop Low Tom f	Vox Aahhh
42	Pop CHH 1 [EXC1]	Vox Tu
43	Pop Low Tom	Vox Dooh
44	Pop CHH 2 [EXC1]	Vox Ptu
45	Pop Mid Tom f	Vox Down
46	Pop OHH [EXC1]	Vox Pa
47	Pop Mid Tom	Vox Bom
C3 48	Pop High Tom f	Vox Toear
49	Pop Crash Cymbal 1	Vox Aahhu
50	Pop High Tom	Vox Toya
51	Pop Ride Cymbal 1	Vox Thu
52	Pop Chinees Cymbal	Vox Cheey
53	Pop Ride Bell	Vox Cymm
54	Tambourine 2	Vox Tub
55	Splash Cymbal	Vox Pruru
56	Cha Cha Cowbell	Vox Tut
57	Pop Crash Cymbal 2	Vox Tyun
58	Vibra-slap 2	Vox Tdum
59	Pop Ride Cymbal 2	Vox Afahhhh
C4 60	High Bongo 2	High Bongo 2
61	Low Bongo 2	Low Bongo 2
62	Mute Conga	Mute Conga
63	High Conga 2	High Conga 2
64	Low Conga 2	Low Conga 2
65	High Timbale 2	High Timbale 2
66	Low Timbale 2	Low Timbale 2
67	High Agogo	High Agogo
68	Low Agogo	Low Agogo
69	Shaker 3	Shaker 3
70	Shaker 4	Shaker 4
71	Short Hi Whistle [EXC2]	Short Hi Whistle [EXC2]
C5 72	Long Low Whistle [EXC2]	Long Low Whistle [EXC2]
73	Short Guiro [EXC3]	Short Guiro [EXC3]
74	Long Guiro [EXC3]	Long Guiro [EXC3]
75	Claves	Claves
76	High Wood Block	High Wood Block
77	Low Wood Block	Low Wood Block
78	Mute Cuica [EXC4]	Mute Cuica [EXC4]
79	Open Cuica [EXC4]	Open Cuica [EXC4]
80	Mute Triangle [EXC5]	Mute Triangle [EXC5]
81	Open Triangle [EXC5]	Open Triangle [EXC5]
82	Shaker	Shaker
83	Jingle Bell	Jingle Bell
C6 84	Bar Chime	Bar Chime
85	Castanets	Castanets
86	Mute Surdo [EXC6]	Mute Surdo [EXC6]
87	Open Surdo [EXC6]	Open Surdo [EXC6]
88	-----	-----
89	Falamento Hi-Timbale	Falamento Hi-Timbale
90	Falamento Lo-Timbale	Falamento Lo-Timbale
91	Falamento Tmbal Flam	Falamento Tmbal Flam
92	Shekere 1	Shekere 1
93	Shekere 2	Shekere 2
94	Low Bongo Mute	Low Bongo Mute
95	-----	-----
C7 96	-----	-----
97	-----	-----
98	-----	-----
99	-----	-----
100	Falamento HC	Falamento HC
101	Falamento HC	Falamento HC
102	Bongo Cowbell	Bongo Cowbell
103	-----	-----
104	Bongo Cowbell	Bongo Cowbell
105	-----	-----

* ---: No sound.

* [EXC]: will not sound simultaneously with other percussion instruments of the same number.

Rhythm List

→ “Selecting a Rhythm” (p. 28)

No.	Genre	Name	Recommended Tempo	Beat
r01	Pop	Cutting Guitar 1	90 ~ 120	4/4
r02	Pop	Cutting Guitar 2	90 ~ 120	4/4
r03	Pop	EP Pop 1	80 ~ 110	4/4
r04	Pop	EP Pop 2	80 ~ 110	4/4
r05	Pop	Acoustic Pop 1	80 ~ 110	4/4
r06	Pop	Acoustic Pop 2	80 ~ 110	4/4
r07	Pop	Piano Pop 1	85 ~ 115	4/4
r08	Pop	Piano Pop 2	85 ~ 115	4/4
r09	Latin	Bossa Nova 1	110 ~ 140	4/4
r10	Latin	Bossa Nova 2	110 ~ 140	4/4
r11	Ballad	Ballad 1	70 ~ 100	4/4
r12	Ballad	Ballad 2	70 ~ 100	4/4
r13	Jazz	Scat Swing 1	100 ~ 130	4/4
r14	Jazz	Scat Swing 2	100 ~ 130	4/4
r15	Pop	Country Pop 1	85 ~ 115	4/4
r16	Pop	Country Pop 2	85 ~ 115	4/4
r17	Pop	EP Pop 3	80 ~ 110	4/4
r18	Pop	EP Pop 4	80 ~ 110	4/4
r19	Shuffle	Shuffle 1	110 ~ 140	4/4
r20	Shuffle	Shuffle 2	110 ~ 140	4/4
r21	Shuffle	Shuffle 3	130 ~ 160	4/4
r22	Shuffle	Shuffle 4	130 ~ 160	4/4
r23	Jazz	Jazz 1	110 ~ 140	4/4
r24	Jazz	Jazz 2	110 ~ 140	4/4
r25	Jazz	Jazz 3	100 ~ 130	4/4
r26	Jazz	Jazz 4	100 ~ 130	4/4
r27	Latin	Beguine 1	90 ~ 120	4/4
r28	Latin	Beguine 2	90 ~ 120	4/4
r29	Latin	Mambo 1	90 ~ 120	4/4
r30	Latin	Mambo 2	90 ~ 120	4/4

No.	Genre	Name	Recommended Tempo	Beat
r31	Pop	Funk Pop 1	90 ~ 120	4/4
r32	Pop	Funk Pop 2	90 ~ 120	4/4
r33	Pop	Funk Pop 3	90 ~ 120	4/4
r34	Pop	Funk Pop 4	90 ~ 120	4/4
r35	Pop	Hip Hop 1	80 ~ 110	4/4
r36	Pop	Hip Hop 2	80 ~ 110	4/4
r37	Pop	Easy Pop 1	100 ~ 130	4/4
r38	Pop	Easy Pop 2	100 ~ 130	4/4
r39	Pop	Cutting Guitar 3	90 ~ 120	4/4
r40	Pop	Cutting Guitar 4	90 ~ 120	4/4
r41	Pop	Fusion 1	85 ~ 115	4/4
r42	Pop	Fusion 2	85 ~ 115	4/4
r43	Pop	Contemporary 1	85 ~ 115	4/4
r44	Pop	Contemporary 2	85 ~ 115	4/4
r45	Ballad	Piano Ballad 1	50 ~ 80	4/4
r46	Ballad	Piano Ballad 2	50 ~ 80	4/4
r47	Ballad	Piano Ballad 3	75 ~ 105	4/4
r48	Ballad	Piano Ballad 4	75 ~ 105	4/4
r49	Waltz	Jazz Waltz 1	90 ~ 120	3/4
r50	Waltz	Jazz Waltz 2	90 ~ 120	3/4
r51	Waltz	Piano Waltz 1	85 ~ 115	3/4
r52	Waltz	Piano Waltz 2	85 ~ 115	3/4
r53	Rock	Gospel Shout 1	125 ~ 155	4/4
r54	Rock	Gospel Shout 2	125 ~ 155	4/4
r55	Blues	Boogie 1	145 ~ 175	4/4
r56	Blues	Boogie 2	145 ~ 175	4/4
r57	Blues	Blues 1	60 ~ 90	4/4
r58	Blues	Blues 2	60 ~ 90	4/4
r59	Rock	Rock 1	110 ~ 140	4/4
r60	Rock	Rock 2	110 ~ 140	4/4

Chord Progression Pattern List

→ “Selecting a Rhythm’s Chord Progression” (p. 30)

Recommended Rhythm Genre: All				
Pattern 1	C	Am	Dm7	G7
	I	VI _m	II _m 7	V7

Recommended Rhythm Genre: All				
Pattern 2	Am	G	F	E7
	I _m	♭VII	♭VI	V7

Recommended Rhythm Genre: Jazz				
Pattern 3	CM7	Am7	Dm7	G7
	I M7	VI _m 7	II _m 7	V7

Recommended Rhythm Genre: Pop, Ballad				
Pattern 4	Dm7	G7	CM7	Am7
	II _m 7	V7	I M7	VI _m 7
	Dm7	G7	CM7	A7
	II _m 7	V7	I M7	VI7

Recommended Rhythm Genre: Pop				
Pattern 5	C	Bm7	Em7	Am
	I	VII _m 7	III _m 7	VI _m
	F	G	Csus4	C
	IV	V	I sus4	I

Recommended Rhythm Genre: Ballad, Jazz				
Pattern 6	Dm7	G7	CM7	FM7
	IV _m 7	♭VII7	♭III M7	♭VI M7
	Bm7 ^{♭5}	E7	Am7	A7
	II _m 7 ^{♭5}	V7	I m7	I7

Recommended Rhythm Genre: Blues, Rock, Pop					
Pattern 7		C7	F7	C7	
		I7	IV7	I7	
		F7		C7	
		IV7		I7	
		G7	F7	C7	G7
		V7	IV7	I7	V7

Recommended Rhythm Genre: Jazz					
Pattern 8		CM7		Cdim	
		I M7		I dim	
		Dm9	G7	CM7	Dm9
		IIIm9	V7	I M7	IIIm9
		CM7		Cdim	
		I M7		I dim	
		Dm9	G7	CM7	
		IIIm9	V7	I M7	

Recommended Rhythm Genre: Latin, Pop					
Pattern 9		C		Am7	
		I		VIm7	
		Dm7		G7sus4	
		IIIm7		V7sus4	

Chord Fingering List

● symbol: indicates the constituent notes of chords.

★ symbol: Chords shown with an “★” can be played by pressing just the key marked with the “★”.

→ “Performing With the Chord Progression Specified in the Left Hand (Rhythm Split Play)” (p. 31)

C	C#	D	E \flat	E	F
CM7	C#M7	DM7	E \flat M7	EM7	FM7
C7	C#7	D7	E \flat 7	E7	F7
Cm	C#m	Dm	E \flat m	Em	Fm
Cm7	C#m7	Dm7	E \flat m7	Em7	Fm7
Cdim	C#dim	Ddim	E \flat dim	Edim	Fdim
Cm7 (\flat 5)	C#m7 (\flat 5)	Dm7 (\flat 5)	E \flat m7 (\flat 5)	Em7 (\flat 5)	Fm7 (\flat 5)
Caug	C#aug	Daug	E \flat aug	Eaug	Faug
Csus4	C#sus4	Dsus4	E \flat sus4	Esus4	Fsus4
C7sus4	C#7sus4	D7sus4	E \flat 7sus4	E7sus4	F7sus4
C6	C#6	D6	E \flat 6	E6	F6
Cm6	C#m6	Dm6	E \flat m6	Em6	Fm6

F#	G	A \flat	A	B \flat	B
F#M7	GM7	A \flat M7	AM7	B \flat M7	BM7
F#7	G7	A \flat 7	A7	B \flat 7	B7
F#m	Gm	A \flat m	Am	B \flat m	Bm
F#m7	Gm7	A \flat m7	Am7	B \flat m7	Bm7
F#dim	Gdim	A \flat dim	Adim	B \flat dim	Bdim
F#m7 (b5)	Gm7 (b5)	A \flat m7 (b5)	Am7 (b5)	B \flat m7 (b5)	Bm7 (b5)
F#aug	Gaug	A \flat aug	Aaug	B \flat aug	Baug
F#sus4	Gsus4	A \flat sus4	Asus4	B \flat sus4	Bsus4
F#7sus4	G7sus4	A \flat 7sus4	A7sus4	B \flat 7sus4	B7sus4
F#6	G6	A \flat 6	A6	B \flat 6	B6
F#m6	Gm6	A \flat m6	Am6	B \flat m6	Bm6

Internal Song List

→ “Listening to Internal Songs” (p. 12)

Song No.	Song Title	Composer	Copyright
d. 1	Jobs For The Boys	J. Maul	© 2000 John Maul
d. 2	Howz It Feel?	S. Wilkie	© 2000 Scott Wilkie (ASCAP)
d. 3	Bop on the Rock	J. Maul	© 1992 Roland Corporation
d. 4	Yesterday's Dream	J. Maul	© 1992 Roland Corporation
P. 1	Arabesque No. 1 in E-Major	C. Debussy	© 1994 Roland Corporation
P. 2	Gymnopedie No. 1	E. Satie	© 1997 Roland Corporation
P. 3	Golliwog's Cakewalk	C. Debussy	© 1996 Roland Corporation
P. 4	Je Te Veux	E. Satie	© 1997 Roland Corporation
P. 5	“Clair de lune” from “Suite Bergamasque”	C. Debussy	© 1990 Roland Corporation
P. 6	“Passepied” from “Suite Bergamasque”	C. Debussy	© 1998 Roland Corporation
P. 7	Nocturne No. 2 in E-flat Major, Op. 9-2	F. Chopin	© 1993 Roland Corporation
P. 8	“Troika Drive: November” from “The Seasons,” Op. 37	P. Tchaikovsky	© 1996 Roland Corporation
P. 9	Polonaise No. 6 in A-flat Major “Héroïque,” Op. 53 (Excerpt)	F. Chopin	© 1994 Roland Corporation
P.10	Piano Sonata No. 14 in C-sharp Minor, “Moonlight” 1st Movement	L. v. Beethoven	© 1998 Roland Corporation
P.11	Rhapsody No. 2, Op. 79	J. Brahms	© 1998 Roland Corporation
P.12	Nocturne No. 5 in F-sharp Major, Op. 15-2	F. Chopin	© 1990 Roland Corporation
P.13	Mazurka No.5 in B-flat Major, Op. 7-1	F. Chopin	© 1995 Roland Corporation
P.14	“Doctor Gradus Ad Parnassum” from Suite “Children's Corner”	C. Debussy	© 1995 Roland Corporation
P.15	Turkish March, Op.113	L. v. Beethoven	© 1996 Roland Corporation
P.16	Etude Op. 25-1 in A-flat Major “The Shepherd Boy”	F. Chopin	© 1995 Roland Corporation
P.17	Etude No. 5 in G-flat Major “Black Keys,” Op. 10-5	F. Chopin	© 1990 Roland Corporation
P. 18	Fantasia-Impromptu Op.66	F. Chopin	© 1994 Roland Corporation
P.19	Valse No. 1 in E-flat Major, Op. 18 “Grand Valse Brillante”	F. Chopin	© 1998 Roland Corporation
P.20	Valse No. 6 in D-flat Major, Op. 64-1 “Petit Chien”	F. Chopin	© 1990 Roland Corporation
P.21	Valse No. 2 in A-flat Major, Op.34-1 “Valse Brillante”	F. Chopin	© 1994 Roland Corporation
P.22	Valse No. 7 in C-sharp Minor, Op. 64-2	F. Chopin	© 1996 Roland Corporation
P.23	Rondo Brillante “Aufforderung Zum Tanz” in D-flat Major, Op. 65	C. M. v. Weber	© 1994 Roland Corporation
P.24	Slavonic Dance No. 10, Op. 72-2	A. Dvořák	© 1998 Roland Corporation
P.25	Menuet in G Major, BWV. Anh. 114 from “Notebook Of Anna Magdalena Bach”	J. S. Bach	© 1992 Roland Corporation
P.26	Bagatelle “Für Elise” WoO. 59	L. v. Beethoven	© 1994 Roland Corporation
P.27	12 Variationen Über Ein Französisches Lied “Ah, Vuos Dirai-Je, Maman,” K. 265	W. A. Mozart	© 1994 Roland Corporation
P.28	Türkisch March (Piano Sonate No. 11 in A Major, 3rd Movement “Alla Turca”)	W. A. Mozart	© 1994 Roland Corporation
P.29	Salut D'Amour Op. 12	E. Elgar	© 1996 Roland Corporation
P.30	A Maiden's Prayer	T. Badarzewska	© 1996 Roland Corporation

Song No.	Song Title	Composer	Copyright
P.31	Spinnerlied Op. 14-4	A. Ellmenreich	© 1994 Roland Corporation
P.32	"Berceuse" from "Dolly," Op. 56	G. Fauré	© 1995 Roland Corporation
P.33	3-Romances Sans Paroles No. 3, Op. 17	G. Fauré	© 1996 Roland Corporation
P.34	"Gavotte" from Opera "Rosine"	F. Gossec	© 1996 Roland Corporation
P.35	"Arietta" from "Lyric Pieces, Volume 1" Op. 12-1	E. Grieg	© 1996 Roland Corporation
P.36	Invention No. 4 in D Minor, BWV. 775	J. S. Bach	© 1998 Roland Corporation
P.37	Invention No. 13 in A-Minor	J. S. Bach	© 1997 Roland Corporation
P.38	Invention Three-Part (Sinfonia) No. 12 in A Major, BWV. 798	J. S. Bach	© 1998 Roland Corporation
P.39	1st Mov. from Sonatina Op. 20 No. 1 in C-Major	F. Kuhlau	© 1996 Roland Corporation
P.40	No. 14 "La Styrienne" from "25 Easy Studies" Op. 100	F. Burgmuller	© 1992 Roland Corporation
P.41	Harmonious Blacksmith	G. Handel	© 1996 Roland Corporation
P.42	La Cinquantaine	G. P. Marie	© 1996 Roland Corporation
P.43	Blumenlied	G. Lange	© 1996 Roland Corporation
P.44	On Wings Of Song	F. Mendelssohn	© 1996 Roland Corporation
P.45	"Frühlingslied" from "Lieder Ohne Worte Heft 5," Op. 62-6	F. Mendelssohn	© 1996 Roland Corporation
P.46	Moment musicaux No. 3, Op. 94-3	F. Schubert	© 1994 Roland Corporation
P.47	Military March No. 1, Op. 51-1	F. Schubert	© 1998 Roland Corporation
P.48	"Fröhlicher Landmann" from "Album Für Die Jugend" Op. 68	R. Schumann	© 1996 Roland Corporation
P.49	"Grande Ritournelle" from "La Belle Excentrique (Fantaisie Serieuse)"	E. Satie	© 1997 Roland Corporation
P.50	"Träumerei" from "Scenes From Childhood" Op. 15	R. Schumann	© 1997 Roland Corporation

* All rights reserved. Unauthorized use of this material for purposes other than private, personal enjoyment is a violation of applicable laws.

* No data for the internal songs that is played will be output from MIDI OUT connector.

■ Profile

John Maul

John Maul is a musician, composer and arranger having graduated from the Royal Academy of Music in London. John's work encompasses studio recordings and live performances including work with top UK Jazz artists. His writing credits include commercial music for BBC radio and television, as well as scoring jazz and classical works.

Having been a product specialist for Roland U.K., John is now actively involved in music software composing/programming for both Roland Japan and various music publishers. Quite recently his "Musical Picture Book," a volume of original piano music encompassing all standards of musical ability, which included the piano and orchestral accompaniment data in SMF format, was published and printed.

Scott Wilkie

Scott Wilkie is a contemporary jazz recording artist, based in southern California. He has several recordings available on Narada-Jazz Records, and he tours frequently with his own band. He also appears worldwide as an artist for Roland. You can find him online at www.scottwilkie.com.

Easy Operation List

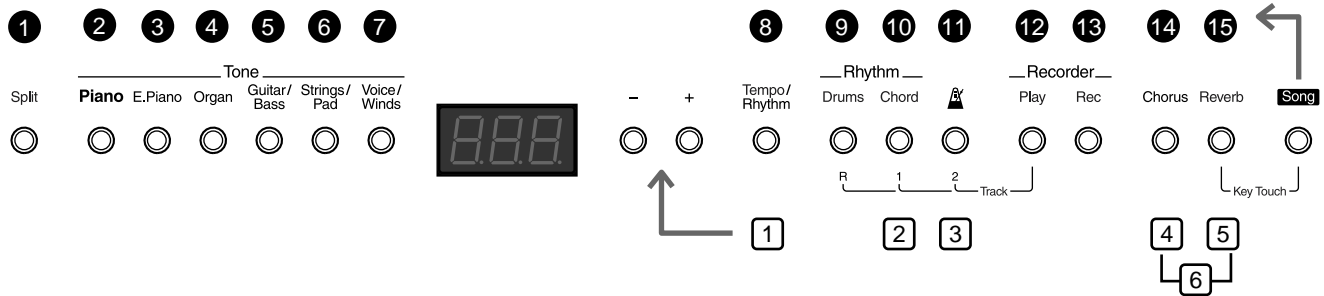

No.	You want to	Buttons	Page
Hold down the [Song] button and press the [●] button.			
①	Volume balance between the Lower and Upper Tone	[Song] + [Split]	p. 18
②	Octave Shift	[Song] + [Piano]	p. 39
③	Pedal works	[Song] + [E.Piano]	p. 38
④	How the pedal effects are applied	[Song] + [Organ]	p. 39
⑤	MIDI send channel settings	[Song] + [Guitar/Bass]	p. 43
⑥	MIDI OutMode	[Song] + [Strings/Pad]	p. 44
⑦	Master Tuning	[Song] + [Voice/Winds]	p. 40
⑧	Local Control	[Song] + [Tempo/Rhythm]	p. 43
⑨	Volume balance between the keyboard and Rhythm	[Song] + [Drums]	p. 32
⑩	Playing only the bass sound of the Chord Part	[Song] + [Chord]	p. 27
⑪	Metronome beat pattern	[Song] + [Metronome]	p. 41
⑫	All Song Play	[Song] + [Play]	p. 12
⑬	Erasing the recorded performance	[Song] + [Rec]	p. 37
⑭	Selecting a temperament Specifying the keynote	[Song] + [Chorus] + key	p. 40
⑮	Key Touch	[Song] + [Reverb]	p. 19
Hold down the [□] button and press the [-] or [+] button.			
①	Beat of metronome	[Tempo/Rhythm] + [-] [+]	p. 24
②	Metronome volume	[Metronome] + [-] [+]	p. 24
③	Selecting a chord progression pattern Specifying the root of the beginning chord	[Chord] + [-] [+] + key	p. 30
④	Depth of the Chorus effect	[Chorus] + [-] [+]	p. 20
⑤	Depth of the Reverb effect	[Reverb] + [-] [+]	p. 21
⑥	Damper pedal's resonance level	[Reverb] + [Chorus] + [-] [+]	p. 38
Hold down the [Split] or [Song] button and press the key.			
	Split Point	[Split] + key	p. 17
	Key Transpose	[Song] + key	p. 22

MIDI Implementation Chart

Function...		Transmitted	Recognized	Remarks
Basic Channel	Default Changed	1 1-16	1-16 1-16	
Mode	Default Messages Altered	Mode 3 x *****	Mode 3 Mode 3, 4(M=1)	* 2
Note Number :	True Voice	15-113 *****	0-127 0-127	
Velocity	Note ON Note OFF	O x 8n v=64	O x	
After Touch	Key's Ch's	x x	O *1 O *1	
Pitch Bend		x	O	
Control Change	0, 32 7 10 11 64 66 67 91 93	O *3 x x O O O O *3 O *3 O	O *1 O *1 O *1 O *1 O *1 O *1 O (Reverb) *1 O (Chorus) *1	Bank select Volume Panpot Expression Hold 1 Sostenuto Soft Effect1 depth Effect3 depth
Prog Change	: True Number	O 0-37, 63 *3 *****	O 0-37, 63	Program number 1-38, 64
System Exclusive		O	O	
System Common	: Song Pos : Song Sel : Tune	x x x	x x x	
System Real Time	: Clock : Commands	O x	x x	
Aux Message	: All sound off : Reset all controllers : Local Control : All Notes OFF : Active Sense : Reset	x x x x O x	O (120, 126, 127) O O O (123-125) O O x	
Notes	* 1 O x is selectable by SysEx. * 2 Recognized as M=1 even if M≠1. * 3 Not transmitted when MIDI Out Mode (p. 44) is set to "2."			

Mode 1 : OMNI ON, POLY

Mode 2 : OMNI ON, MONO

O : Yes

Mode 3 : OMNI OFF, POLY

Mode 4 : OMNI OFF, MONO

X : No

Main Specifications

<Keyboard>

88 keys (Progressive Hammer Action Keyboard)

Touch Sensitivity

Light/Normal/Heavy/Fixed

Keyboard Mode

Whole

Dual

Split (adjustable split point)

<Sound Source>

Max. Polyphony

64 voices

Tones

6 groups 40 variations (including 2 drum sets)

Effects

Reverb (10 levels)

Chorus (10 levels)

Sympathetic Resonance (10 levels, for some Pianos only)

Rotary (for some Organs only)

Transpose

-6 to +5 (semitone steps)

Temperament

7 types, selectable tonic

Master Tuning

415.3 Hz to 466.2 Hz (0.1 Hz Step)

<Rhythm>

Rhythms

60 Rhythms

Chord Progression

Automatic or input with keyboard

<Recorder>

Metronome

Beat: 2/2,0/4,2/4,3/4,4/4,5/4, 6/4,7/4,3/8,6/8,9/8,12/8

Volume: 10 levels

Pattern: 11 patterns

Tracks

3 tracks

Song

1 song

Note Storage

Approx. 30,000 notes

Tempo

Quarter note = 20 to 250

Resolution

120 ticks per quarter note

58

<Others>

Display

7-segment, 3-digit LED

Connectors

Line Out jacks (L/Mono, R)

Line In jacks (L/Mono, R)

Phones jack x 2 (Stereo Mini)

MIDI connectors (In/Out)

Pedal jacks (Damper, Soft/Sostenuto/Expression)

Power Supply

DC 9 V

Power Consumption

1,000 mA

Dimensions

1,291 (W) x 302 (D) x 124(H) mm

50-7/8(W) x 11-15/16 (D) x 4-15/16(H) inch

Weights

18.5 kg / 40 lbs 13 oz

Accessories

Owner's manual

AC adaptor

AC cord

Music Stand/2 Screws for the music stand

Audio cables

Pedal

Cover

** In the interest of product improvement, the specifications and/or appearance of this unit are subject to change without prior notice.*

Index

A		
AC adaptor	9	
All Song Play	12	
B		
Beat	24	
Brilliance	11	
C		
Chord	52	
Chord Fingering List	52	
Chord Part	25, 26	
Bass	27	
Chord progression		
Automatic	26	
Selecting pattern	30	
Specifying the chords	31	
Chord Progression Pattern List	50	
Chorus Effect	20	
Changing the depth	20	
Connection	8	
D		
Damper	10	
Damper Pedal	8, 10, 38	
Display	47	
Drum Part	25, 26	
Dual Play	15	
E		
Easy Operation List	56	
Erasing	37	
Expression pedal	8, 38	
F		
Fill In	28	
H		
Headphones	11	
I		
Including pedal	10	
Internal Song	12	
Recording.....	36	
Internal Song List	54	
K		
Key Transpose	22	
Keyboard's Touch (Key Touch)	19	
L		
Line Out	9	
Local Control	43	
Lower Tone	15, 16	
M		
Master Tuning	40	
Messages	47	
Metronome	23	
Beat Pattern	41	
Volume	24	
MIDI	42	
MIDI Device	42	
MIDI In/Out	42	
MIDI Out Mode	44	
MIDI Send Channel	43	
MIDI Sound Module	42	
Music Stand	9	
Muting	13	
O		
Octave Shift	39	
Operation List	56	
P		
Pedal	10, 38, 39	
Phones	11	
Pitch	40	
Playback		
All Songs	12	
Each part separately	13	
Internal song	12	
Power	10	
R		
Recording	33	
Along with internal songs	36	
Performance using Rhythms	34	
Performance using Rhythms in Split Play	35	
Selected Tracks	36	
Resonance	38	
Reverb Effect	21	
Changing the depth	21	
Rhythm	25, 26, 28	
Rhythm List	49	
Rotary Effect	20	

Index

S

Sequencer	42
Session Partner	25
Soft	10
Soft Pedal	8, 10, 38
Sostenuto pedal	38
Split Play	16
Rhythm	31
Split Point	17
Standard pitch	40
Sympathetic Resonance	10, 38

T

Temperament	40
Tempo	23, 29
Tone	14
Tone group	14
Tone List	48
Track Button	
Recording	36, 37
Track button	13
Transpose	22
Troubleshooting	45
Tuning	40

U

Upper Tone	15, 16
------------------	--------

V

Volume	11
Metronome	24
Volume Balance	
Keyboard and Rhythm	32
Lower Tone and Upper Tone	18

MEMO

Information

When you need repair service, call your nearest Roland Service Center or authorized Roland distributor in your country as shown below.

AFRICA

EGYPT

Al Fanny Trading Office
9, EBN Hagar A1 Askalany Street,
ARD El Golf, Heliopolis,
Cairo 11341, EGYPT
TEL: 20-2-417-1828

REUNION

Maison FO - YAM Marcel
25 Rue Jules Hermann,
Chaudron - BP79 97 491
Ste Clotilde Cedex,
REUNION ISLAND
TEL: (0262) 218-429

SOUTH AFRICA

**That Other Music Shop
(PTY) Ltd.**
11 Melle St., Braamfontein,
Johannesbourg, SOUTH AFRICA

P.O.Box 32918, Braamfontein 2017
Johannesbourg, SOUTH AFRICA
TEL: (011) 403 4105

Paul Bothner (PTY) Ltd.
17 Werdmuller Centre,
Main Road, Claremont 7708
SOUTH AFRICA

P.O.Box 23032, Claremont 7735,
SOUTH AFRICA
TEL: (021) 674 4030

ASIA

CHINA

**Beijing Xinghai Musical
Instruments Co., Ltd.**
6 Huangmunchang Chao Yang
District, Beijing, CHINA
TEL: (010) 6774 7491

**Shanghai Xingtong Acoustics
Equipment CO., Ltd.**
5F, No.1500 Pingliang Road
New East Club Plaza, Shanghai,
CHINA
TEL: (021) 5580-0800

HONG KONG

**Tom Lee Music Co., Ltd.
Service Division**
22-32 Pun Shan Street, Tsuen
Wan, New Territories,
HONG KONG
TEL: 2415 0911

INDIA

Rivera Digitec (India) Pvt. Ltd.
409, Nirman Kendra Mahalaxmi
Flats Compound Off. Dr. Edwin
Moses Road, Mumbai-400011,
INDIA
TEL: (022) 498 3079

INDONESIA

PT Citra IntiRama
J1. Cideng Timur No. 15J-150
Jakarta Pusat
INDONESIA
TEL: (021) 6324170

KOREA

Cosmos Corporation
1461-9, Seocho-Dong,
Seocho Ku, Seoul, KOREA
TEL: (02) 3486-8855

MALAYSIA

BENTLEY MUSIC SDN BHD
140 & 142, Jalan Bukit Bintang
55100 Kuala Lumpur, MALAYSIA
TEL: (03) 2144-3333

PHILIPPINES

G.A. Yupangco & Co. Inc.
339 Gil J. Puyat Avenue
Makati, Metro Manila 1200,
PHILIPPINES
TEL: (02) 899 9801

SINGAPORE

Swee Lee Company
150 Sims Drive,
SINGAPORE 387381
TEL: 846-3676

CRISTOFORI MUSIC PTE LTD

Blk 3014, Bedok Industrial Park E,
#02-2148, SINGAPORE 489980
TEL: 243 9555

TAIWAN

**ROLAND TAIWAN
ENTERPRISE CO., LTD.**
Room 5, 9fl. No. 112 Chung Shan
N.Road Sec.2, Taipei, TAIWAN,
R.O.C.
TEL: (02) 2561 3339

THAILAND

Theera Music Co., Ltd.
330 Verg NakornKasem, Soi 2,
Bangkok 10100, THAILAND
TEL: (02) 2248821

VIETNAM

Saigon Music
138 Tran Quang Khai St.,
District 1
Ho Chi Minh City
VIETNAM
TEL: (08) 844-4068

AUSTRALIA/ NEW ZEALAND

AUSTRALIA

**Roland Corporation
Australia Pty., Ltd.**
38 Campbell Avenue
Dee Why West, NSW 2099
AUSTRALIA
TEL: (02) 9982 8266

NEW ZEALAND

Roland Corporation Ltd.
32 Shaddock Street, Mount Eden,
Auckland, NEW ZEALAND
TEL: (09) 3098 715

CENTRAL/LATIN AMERICA

ARGENTINA

Instrumentos Musicales S.A.
Av.Santa Fe 2055
(1123) Buenos Aires
ARGENTINA
TEL: (011) 4508-2700

BRAZIL

Roland Brasil Ltda
Rua San Jose, 780 Sala B
Parque Industrial San Jose
Cotia - Sao Paulo - SP, BRAZIL
TEL: (011) 4615 5666

COSTA RICA

**JUAN BANSBACH
Instrumentos Musicales**
Ave.1. Calle 11, Apartado 10237,
San Jose, COSTA RICA
TEL: 258-0211

CHILE

Comercial Fancy II S.A.
Rut.: 96.919.420-1
Nataníel Cox #739, 4th Floor
Santiago - Centro, CHILE
TEL: (02) 688-9540

EL SALVADOR

OMNI MUSIC
75 Avenida Norte y Final
Alameda Juan Pablo II,
Edificio No.4010 San Salvador,
EL SALVADOR
TEL: 262-0788

MEXICO

Casa Veerkamp, s.a. de c.v.
Av. Toluca No. 323, Col. Olivar
de los Padres 01780 Mexico D.F.
MEXICO
TEL: 668-0480

PANAMA

SUPRO MUNDIAL, S.A.
Boulevard Andrews, Albrook,
Panama City, REP. DE PANAMA
TEL: 315-0101

PARAGUAY

**Distribuidora De
Instrumentos Musicales**
J.E. Olear y ESQ. Manduvira
Asuncion PARAGUAY
TEL: (021) 492-124

PERU

VIDEO Broadcast S.A.
Portinari 199 (ESQ. HALS),
San Borja, Lima 41,
REP. OF PERU
TEL: (01) 4758226

URUGUAY

Todo Musica S.A.
Francisco Acuna de Figueroa 1771
C.P.: 11.800
Montevideo, URUGUAY
TEL: (02) 924-2335

VENEZUELA

Musicland Digital C.A.
Av. Francisco de Miranda,
Centro Parque de Cristal, Nivel
C2 Local 20 Caracas
VENEZUELA
TEL: (212) 285-8586

EUROPE

AUSTRIA

Roland Austria GES.M.B.H.
Siemensstrasse 4, P.O. Box 74,
A-6063 RUM, AUSTRIA
TEL: (0512) 26 44 260

BELGIUM/HOLLAND/ LUXEMBOURG

Roland Benelux N. V.
Houtstraat 3, B-2260, Oevel
(Westerlo) BELGIUM
TEL: (014) 575811

DENMARK

Roland Scandinavia A/S
Nordhavnsvej 7, Postbox 880,
DK-2100 Copenhagen
DENMARK
TEL: (039)16 6200

FRANCE

Roland France SA
4, Rue Paul Henri SPAAK,
Parc de l'Esplanade, F 77 462 St.
Thibault, Lagny Cedex FRANCE
TEL: 01 600 73 500

FINLAND

**Roland Scandinavia As,
Filial Finland**
Lauttasarentie 54 B
Fin-00201 Helsinki, FINLAND
TEL: (9) 682 4020

GERMANY

**Roland Elektronische
Musikinstrumente HmbH.**
Oststrasse 96, 22844 Norderstedt,
GERMANY
TEL: (040) 52 60090

GREECE

**STOLLAS S.A.
Music Sound Light**
155, New National Road
Patras 26442, GREECE
TEL: (061) 43-5400

HUNGARY

Intermusica Ltd.
Warehouse Area 'DEPO' Pf.83
H-2046 Torokbalint, HUNGARY
TEL: (23) 511011

IRELAND

Roland Ireland
Audio House, Belmont Court,
Donnybrook, Dublin 4.
Republic of IRELAND
TEL: (01) 2603501

ITALY

Roland Italy S. p. A.
Viale delle Industrie 8,
20020 Arese, Milano, ITALY
TEL: (02) 937-78300

NORWAY

**Roland Scandinavia Avd.
Kontor Norge**
Lilleakerveien 2 Postboks 95
Lilleaker N-0216 Oslo
NORWAY
TEL: 273 0074

POLAND

P. P. H. Brzostowicz
UL. Gibraltarska 4,
PL-03664 Warszawa POLAND
TEL: (022) 679 44 19

PORTUGAL

**Tecnologias Musica e Audio,
Roland Portugal, S.A.**
Cais Das Pedras, 8/9-1 Dto
4050-465 PORTO
PORTUGAL
TEL: (022) 608 00 60

ROMANIA

FBS LINES
Piata Libertatii 1,
RO-4200 Gheorgheni
TEL: (095) 169-5043

RUSSIA

MuTek
3-Bogatyrskaya Str. 1.k.1
107 564 Moscow, RUSSIA
TEL: (095) 169 5043

SPAIN

**Roland Electronics
de España, S. A.**
Calle Bolivia 239, 08020
Barcelona, SPAIN
TEL: (93) 308 1000

SWEDEN

**Roland Scandinavia A/S
SWEDISH SALES OFFICE**
Danvik Center 28, 2 tr.
S-131 30 Nacka SWEDEN
TEL: (08) 702 0020

SWITZERLAND

**Roland (Switzerland) AG
Musitronic AG**
Gerberstrasse 5, Postfach,
CH-4410 Liestal, SWITZERLAND
TEL: (061) 927-8383

UKRAINE

TIC-TAC
Mira Str. 19/108
P.O. Box 180
295400 Munkachevo, UKRAINE
TEL: (03131) 414-40

UNITED KINGDOM

Roland (U.K.) Ltd.
Atlantic Close, Swansea
Enterprise Park, SWANSEA
SA7 9FJ,
UNITED KINGDOM
TEL: (01792) 700139

MIDDLE EAST

BAHRAIN

Moon Stores
No.16, Bab Al Bahrain Avenue,
P.O.Box 247, Manama 304,
State of BAHRAIN
TEL: 211 005

CYPRUS

Radex Sound Equipment Ltd.
17, Diagorou Street, Nicosia,
CYPRUS
TEL: (02) 66-9426

IRAN

MOCO, INC.
No.41 Nike St., Dr.Shariyati Ave.,
Roheroye Cerahe Mirdamad
Tehran, IRAN
TEL: (021) 285-4169

ISRAEL

**Halilit P. Greenspoon &
Sons Ltd.**
8 Retzif Ha'aliya Hashnya St.
Tel-Aviv-Yafo ISRAEL
TEL: (03) 6823666

JORDAN

AMMAN Trading Agency
245 Prince Mohammad St.,
Amman 1118, JORDAN
TEL: (06) 464-1200

KUWAIT

Easa Husain Al-Yousifi
Abdullah Salem Street,
Safat, KUWAIT
TEL: 243-6399

LEBANON

A. Chahine & Fils
Gerge Zeidan St., Chahine Bldg.,
Achrafieh, P.O.Box: 16-5857
Beirut, LEBANON
TEL: (01) 20-1441

QATAR

**Al Emadi Co. (Badie Studio
& Stores)**
P.O. Box 62,
Doha, QATAR
TEL: 4423-554

SAUDI ARABIA

**aDawlah Universal
Electronics APL**
Corniche Road, Aldossary Bldg.,
1st Floor, Alkhobar,
SAUDI ARABIA

P.O.Box 2154, Alkhobar 31952
SAUDI ARABIA
TEL: (03) 898 2081

SYRIA

**Technical Light & Sound
Center**
Bldg. No. 47,
Khaled Ebn Al Walid St.
Damascus, SYRIA
TEL: (011) 221-1230

TURKEY

**Barkat muzik aletleri ithalat
ve ihracat Ltd Sti**
Siraselviler Caddesi Siraselviler
Pasaji No:74/20
Taksim - Istanbul, TURKEY
TEL: (0212) 2499324

U.A.E.

**Zak Electronics & Musical
Instruments Co. L.L.C.**
Zabeel Road, Al Sherooq Bldg.,
No. 14, Grand Floor, Dubai, U.A.E.
TEL: (04) 3360715

NORTH AMERICA

CANADA

**Roland Canada Music Ltd.
(Head Office)**
5480 Parkwood Way Richmond
B. C., V6W 2M4 CANADA
TEL: (0604) 270 6626

**Roland Canada Music Ltd.
(Toronto Office)**

Unit 2, 109 Woodbine Downs
Bldv, Etobicoke, ON
M9W 6Y1 CANADA
TEL: (0416) 213 9707

U. S. A.

Roland Corporation U.S.
5100 S. Eastern Avenue
Los Angeles, CA 90040-2938,
U. S. A.
TEL: (323) 890 3700

As of January 1, 2002 (Roland)



This product complies with the requirements of European Directive 89/336/EEC.

For EU Countries

FEDERAL COMMUNICATIONS COMMISSION RADIO FREQUENCY INTERFERENCE STATEMENT

This equipment has been tested and found to comply with the limits for a Class B digital device, pursuant to Part 15 of the FCC Rules. These limits are designed to provide reasonable protection against harmful interference in a residential installation. This equipment generates, uses, and can radiate radio frequency energy and, if not installed and used in accordance with the instructions, may cause harmful interference to radio communications. However, there is no guarantee that interference will not occur in a particular installation. If this equipment does cause harmful interference to radio or television reception, which can be determined by turning the equipment off and on, the user is encouraged to try to correct the interference by one or more of the following measures:

- Reorient or relocate the receiving antenna.
- Increase the separation between the equipment and receiver.
- Connect the equipment into an outlet on a circuit different from that to which the receiver is connected.
- Consult the dealer or an experienced radio/TV technician for help.

Unauthorized changes or modification to this system can void the users authority to operate this equipment.
This equipment requires shielded interface cables in order to meet FCC class B Limit.

For the USA

NOTICE

This Class B digital apparatus meets all requirements of the Canadian Interference-Causing Equipment Regulations.

AVIS

Cet appareil numérique de la classe B respecte toutes les exigences du Règlement sur le matériel brouilleur du Canada.

For Canada

This owner's manual is printed on recycled paper.

Roland Corporation

02349012

'02-7-AE2-61N

Free Manuals Download Website

<http://myh66.com>

<http://usermanuals.us>

<http://www.somanuals.com>

<http://www.4manuals.cc>

<http://www.manual-lib.com>

<http://www.404manual.com>

<http://www.luxmanual.com>

<http://aubethermostatmanual.com>

Golf course search by state

<http://golfingnear.com>

Email search by domain

<http://emailbydomain.com>

Auto manuals search

<http://auto.somanuals.com>

TV manuals search

<http://tv.somanuals.com>