

SCHEMATIC

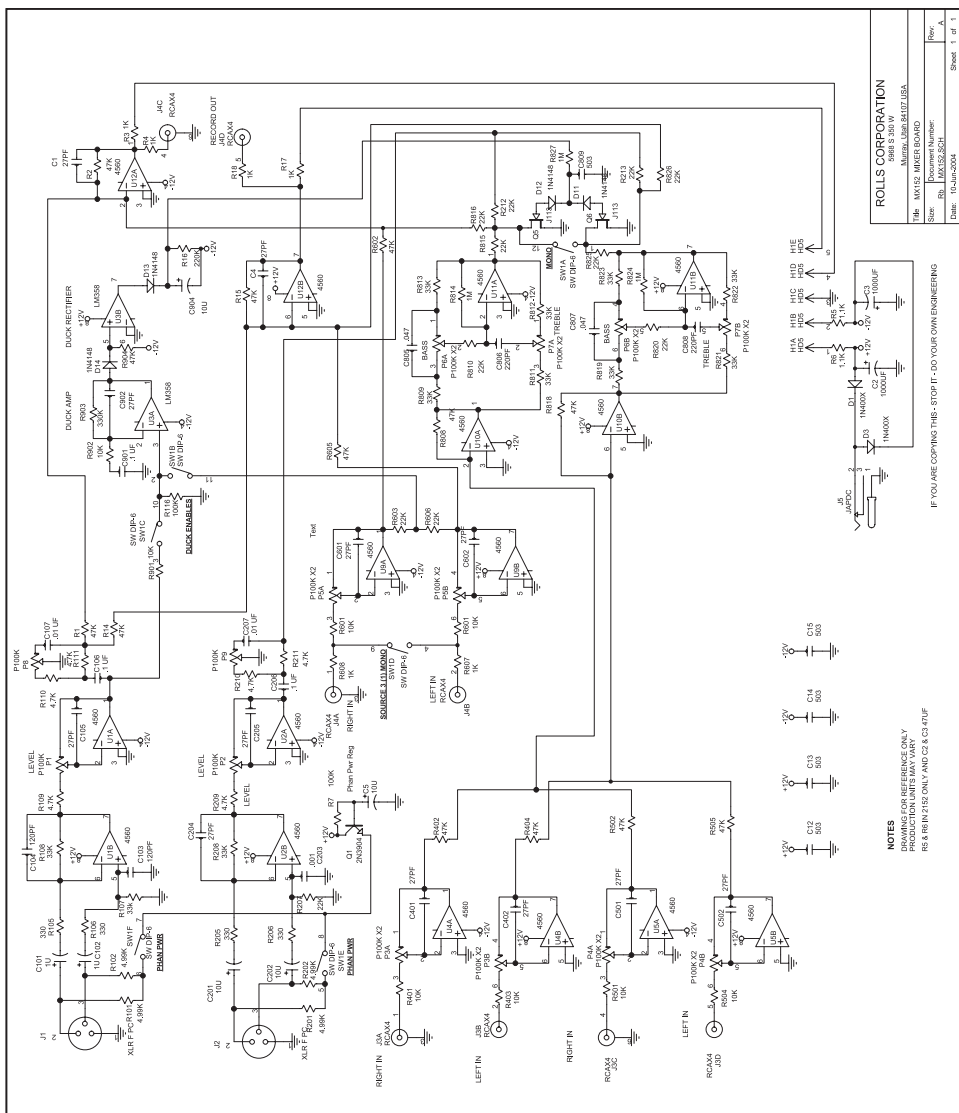

ROLLS

MX152 MixMate Mic/Line Mixer



SPECIFICATIONS

Input Impedance: Mic:	600 Ohms XLR balanced
Source:	22K Ohms RCA
Max Input Level: Mic:	-14 dBV Mic level Max
Source:	24 dBV
Connectors:	2: XLR, 8: Stereo RCA
Phantom Power:	+12 VDC
Max Gain: Mic:	60 dBV
Source:	26 dBV
Tone Controls:	+/-12 dB 100 Hz Bass +/-12 dB 11kHz Treble
Noise Floor:	- 80 dB
S/N Ratio:	96 dB
Priority Attenuation:	60 dB
Power:	12VAC / 600 mA
Size:	5.4" x 1.7" x 5.5"
Weight:	2 lbs

MX152 MIXMATE



6 75889 00152 5



ROLLS
ROLLS CORPORATION
SALT LAKE CITY, UTAH

6/04

INTRODUCTION

Thank you for your purchase of the Rolls MX152 MixMate. The MX152 is a two microphone, three source stereo mixer designed for restaurants, schools, churches, clubs etc. The unit provides a compact and efficient way to mix sources such as AM/FM tuners, CD players, and video players with dynamic or condenser microphones. Priority talkover is provided on Microphone One for paging, and on Source Three for a jukebox, telephone, etc.

NOTE: THIS MANUAL ASSUMES THE USER HAS A WORKING KNOWLEDGE OF AUDIO ELECTRONICS, BALANCED AND UNBALANCED CONNECTIONS, AND PROPER SIGNAL LEVEL SETTING.

INSPECTION / WARRANTY

1. Unpack and inspect the MX152 box and package. If obvious physical damage is noticed, contact the carrier immediately to make a damage claim. We suggest saving the shipping carton and packing materials for safely transporting the unit in the future.
2. Please visit our website at www.rolls.com and click on the Register Your Warranty Here button, or complete the Warranty Registration Card and return it to the factory.

DESCRIPTION

FRONT PANEL

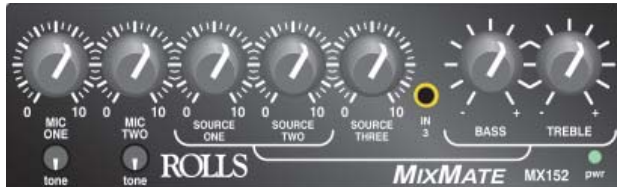

Mic 1, 2: Adjust the level of signal from the corresponding Mic Input.

TONE 1, 2: Adjusts the frequency content of the microphone signal in the channel. When the control is turned counter-clockwise, the high frequencies are cut, when the control is turned clockwise, the low frequencies are cut.

Source 1 - 3: Adjust the volume of input from the RCA Source Inputs.

IN 3: Front panel 1/8" stereo input, linked to source 3.

Bass: Adjusts the low frequencies of the Source 1 and 2 signals only.

Treble: Adjusts the high frequencies of the Source 1 and 2 signals only.

pwr: LED indicating power is applied to the MX152 and the unit is on.

REAR PANEL



12VAC / 600 mA: Power input connector. Connects to the Rolls PS12 Power Adapter.

OUTPUT: Stereo RCA jacks, contains all mixed signals.

SOURCE INPUTS: Stereo RCA jacks, Channels 1 - 3, for connection to stereo sources such as AM/FM tuners, cassette players, cd players, or video players.

DIP SWITCH: Contains the small switches for engaging Mic 1, 2 phantom power, Source 3 Stereo or Mono, the priority (Talk Over) functions, and the Mono/Stereo select.

MICROPHONE ONE and TWO: Balanced XLR inputs to be connected to dynamic or

condenser microphones.

CONNECTION

Inputs

Connect low impedance microphones to the Mic XLR inputs. If a paging microphone is being used, connect it to Mic Input 1 so it may be used with the Talk Over function. Connect source signals such as CD players, cassette players or video players to the RCA Source Inputs. If a jukebox is being connected, and you want its signal to mute the other source signals, connect it to Source input 3.

Output

Connect a stereo RCA cable to the main Output jack, and to an amplifier or the next device in your signal chain.

Shown here is a connection example for the MX152.

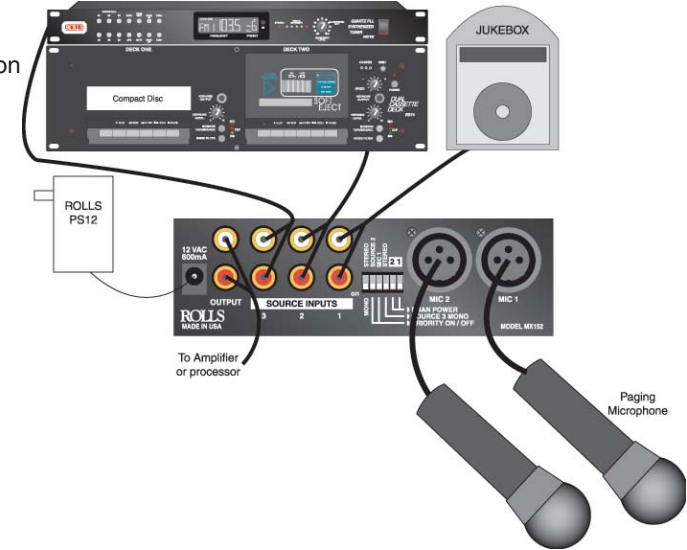

OPERATION

DIP SWITCH SETTINGS (From left to right)

- The Mono/Stereo switch selects the output mode. When the switch is up, the unit is in stereo mode. When the switch is down, the stereo signals are mixed to mono and sent to both the Right and Left Main output jacks. Either jack can be used as a mono output.

- Source 3 Priority: when in the down position, Source 1, and 2 will be "ducked" or muted by the signals at Source 3.

This function is for jukebox priority. With a jukebox connected to Source input 3, and the Talkover switch 2 on (down), the other Source input signals such as background music, will be muted and only the jukebox will be heard.

- Mic 1 Priority; when in the down position, all program material on Mic 2, Source 1 and 2 inputs will be "ducked" or muted when a signal is present at Mic 1. Source 3 is left unmuted. This function is used for paging.

- Source 3 Mono; this switch sums the Right and Left inputs of Source 3 to a mono signal.

- If a microphone requires phantom power, move the Mic channel's corresponding PHAN DIP switch to the down position. This applies 12 volts dc phantom power to the indicated microphone.

Free Manuals Download Website

<http://myh66.com>

<http://usermanuals.us>

<http://www.somanuals.com>

<http://www.4manuals.cc>

<http://www.manual-lib.com>

<http://www.404manual.com>

<http://www.luxmanual.com>

<http://aubethermostatmanual.com>

Golf course search by state

<http://golfingnear.com>

Email search by domain

<http://emailbydomain.com>

Auto manuals search

<http://auto.somanuals.com>

TV manuals search

<http://tv.somanuals.com>