

OWNERS MANUAL

Ride-On Lawnmower —

Rancher Auto Drive™

Model Nos. 28169

28168

28155

*GREAT START
GREAT FINISH*

ROVER™

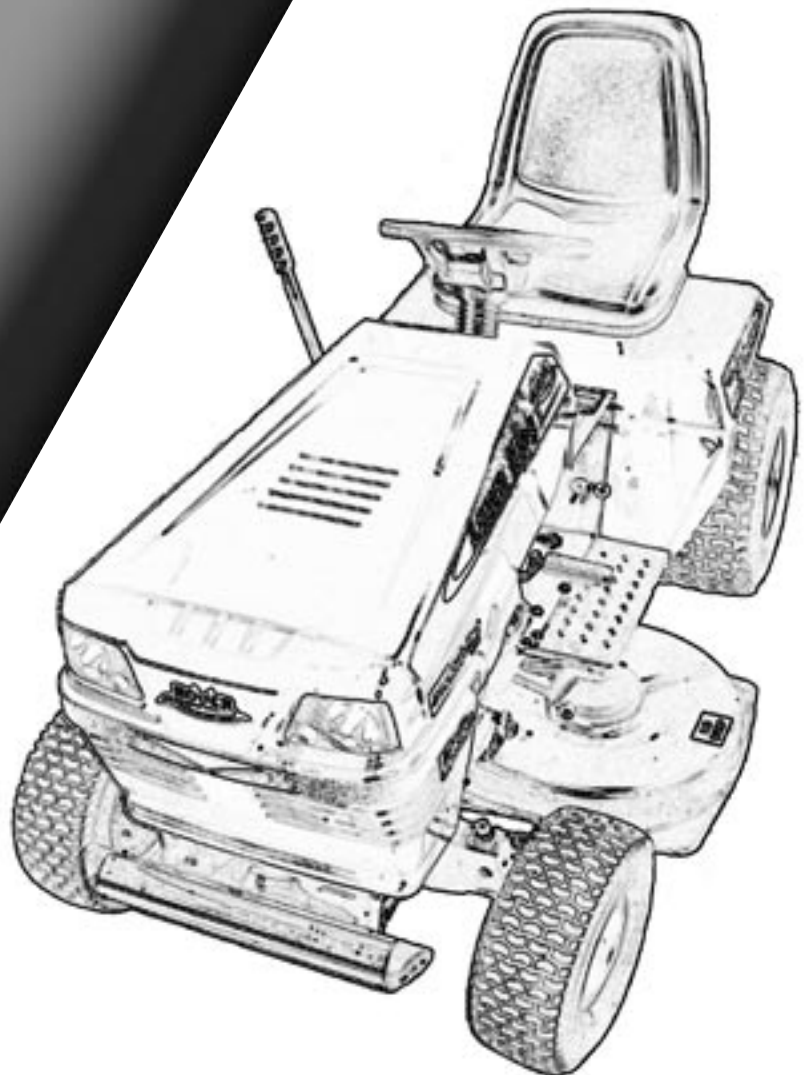

SAFETY INSTRUCTIONS



This product is manufactured to comply with Australian Safety Standards. If non-genuine replacement parts; including blades; are fitted to this product it may no longer meet that Australian Safety Standard and Rover Mowers Warranty. The fitting of non-genuine replacement parts could result in a serious injury, and, or machine malfunctioning which may result in litigation against the person or persons responsible for the alterations.

- * Know your controls. Read the owner's manual carefully. Learn how to stop the engine quickly in any emergency.
- * Do not allow children or people unfamiliar with these instructions to use the mower. Do not carry passengers.
- * Make sure the lawn is clear of sticks, stones, bones, wire and debris. They could be thrown by the blade.
- * Do not mow whilst people, especially children, or pets are in the mowing area.
- * Never mow across the face of the slope, unless the mower is designed for this purpose.
- * Exercise extreme caution when on slopes. Reduce speed on slopes and in sharp turns to prevent overturning or loss of control. Do not stop or start suddenly when going uphill or downhill.
- * Stay alert for holes in the terrain and other hidden hazards. Use care when pulling loads or using heavy equipment
 - (a) use only approved drawbar hitch points
 - (b) limit loads to those you can safely control
 - (c) do not turn sharply
 - (d) use care when backing up, and
 - (e) use counterweight(s) or wheel weights when suggested in the owner's manual.
- * Watch out for traffic when crossing or operating the mower near roadways.
- * Stop the blades rotating before crossing surfaces other than grass.
- * When using any attachments, never direct discharge of material toward bystanders nor allow anyone near the machine while it is in operation.
- * Before leaving the operator's position -
 - (a) disengage all clutches and secure cutting units
 - (b) change into neutral and set the parking brake, and
 - (c) stop the engine and remove the key.
- * Stop the engine and disengage drive to attachments -
 - (a) before refuelling
 - (b) before making height adjustment unless adjustment can be made from the operator's position
 - (c) before clearing blockages
 - (d) before checking, cleaning or working on the mower
 - (e) after striking a foreign object (inspect the mower for damage and make repairs before restarting and operating the equipment) and
 - (f) if machine starts to vibrate abnormally (check immediately).
- * Disengage drive to attachments when transporting or not in use.
- * A mower operator should be in good physical and mental health and not under the influence of any drug or alcohol which might impair vision, co-ordination or judgement.
- * Never mow while barefoot or wearing open sandals, or thongs. Wear long trousers and heavy shoes.
- * It is advisable to wear suitable eye protection when operating a mower.
- * Mow only in good daylight.
- * Before using, always visually inspect to see that blades, blade bolts and cutter assembly are not worn or damaged.
- * Replace worn or damaged blades and bolts in sets to preserve balance.

DAMAGED BLADES AND WORN BOLTS ARE MAJOR HAZARDS

- * Check all nuts, bolts and screws often, always be sure the mower is in a safe operating condition.
- * Keep safety devices (guards and switches) in place and in working order.
- * Never use the mower unless the grass catcher, or guards provided by the manufacturer, are in position.
- * Ensure any spare parts used comply with the original manufacturer's recommendations and specifications.
- * Replace worn or faulty silencer.
- * Keep engine free of grass, leaves or excessive grease. These can be a fire hazard.
- * Refuel outdoors only. Do not smoke while fuelling engine. Never remove the cap of the fuel tank or add petrol while the engine is running or the engine is hot. Remove fuel cap slowly to relieve any tank pressure. If petrol is spilled, do not attempt to start the engine but move machine away from the area of the spill and avoid creating any source of ignition until petrol vapours have dissipated.
- * Check for fuel leaks while refuelling or using the mower. If a fuel leak is found, do not start or run the engine until the fuel leak is fixed and spilled fuel is wiped away.
- * Do not operate the engine in a confined space where exhaust fumes (carbon monoxide) can collect.
- * Always mount the mower on the opposite side to the discharge chute.
- * Start the engine carefully with the cutting means disengaged.
- * Do not over-speed the engine or alter governor settings. Excessive speed is dangerous and shortens mower life.
- * Stop the engine whenever you leave the mower, even for a moment.
- * Store the mower in a well-ventilated room away from naked flames such as may be found in hot water heaters.
- * Do not lend or sell the mower without the Owner's Manual.



WARNING

If fitted with accessories, including any authorised Rover accessories such as Grass Catcher, this mower may not comply with AS 3792.1

Congratulations you have purchased a quality Australian made product made by a totally Australian owned Company (Rover Mowers Limited).

This manual covers the operation and maintenance of the Rancher Auto-Drive mower.
 Please read and understand this owners manual, and the accompanying engine manufacturers manual.
 If any point is unclear, contact Rover Mowers Limited or any authorised Rover Mower service dealer.

To emphasise special information, the words WARNING and CAUTION are used.

	WARNING
The safety of the user and others involved. Personal injury may result should this information be disregarded.	

	CAUTION
Follow these instructions to avoid mower damage and possible loss of warranty.	

CONTENTS	Page
Safety instructions	i
Preface	ii
1. Specifications	1
1.1 Engine	1
1.2 Transmission	1
1.3 Cutterheads	1
1.4 Tyres	1
1.5 Loose parts kit	1
2. Setting up	1
2.1 Installing the steering wheel	1
2.2 Installing the stoneguard	1
2.3 Installing the battery	1
3. Controls	2
3.1 Throttle control	2
3.2 Ignition switch	2
3.3 Brake clutch pedal	2
3.4 Parking brake	2
3.5 Speed selector	2
3.6 Cut height and engagement lever	2
3.7 Safety interlock system	2
4. Before starting	3
4.1 Engine lubrication	3
4.2 Fuel	3
4.3 Seat adjustment	3
5. Operation	3
5.1 To start the engine	3
5.2 To drive or mow	3
5.3 To stop the engine	3
5.4 Engaging clutches	3
5.5 Cutterhead	3
6. Maintenance	4
6.1 Oil change	4
6.2 Lubrication points	4
6.3 Wheel removal	4
6.4 Rear Hub removal	4
6.5 Rear Hub fitment	4
6.6 Steering Gear adjustment	4
6.7 Cutterhead removal	5

6.8 Cutterhead leveling	5
6.9 Cutterhead tilt	5
6.10 Cutterhead low cut setting	5
6.11 Cutterhead disengagement	6
6.12 Cutterhead brake adjustment	6
6.13 Cutterhead brake pad replacement	6
6.14 Brake caliper adjustment	6
6.15 Brake arm adjustment	6
6.16 Auto-Drive unit removal	6
6.17 Auto belt tensioner	7
6.18 Drive belt removal	7
6.19 Drive belt installation	7
6.20 Primary drive chain adjustment	7
6.21 Secondary drive chain adjustment	7
6.22 Drive selector pedal adjustment	8
6.23 Auto drive engine belt	8
6.24 Auto drive engine belt replacement	8
6.25 Autodrive neutralising adjustment	8
6.26 Safety interlock adjustment	8
6.27 Front Axle Beam	9
6.28 Maintenance chart	9
6.29 Electrical system- 13HP	10
6.30 Electrical system- 15.5 and 18HP	11
7. Trouble shooting	12

ILLUSTRATIONS

Figure 3.1 Dash panel and foot pedal	2
Figure 3.2 Foot and hand controls	2
Figure 6.3 Steering pivot block	4
Figure 6.4 Cutterhead support plates	5
Figure 6.5 Cutterhead conbar	5
Figure 6.6 Cutterhead lift rod	5
Figure 6.7 Cutterhead engagement rollers	6
Figure 6.8 Disk brake caliper arm	6
Figure 6.9 Auto-Drive unit	6
Figure 6.10 Belt tension spring removal	7
Figure 6.11 Auto belt tensioner	7
Figure 6.12 Primary drive chain	7
Figure 6.13 Secondary drive chain	7
Figure 6.14 Drive selector pedal	8
Figure 6.15 Autodrive neutralising adjustment	8
Figure 6.16 Clutch brake safety switch	8
Figure 6.17 Cutterhead safety switch	8
Figure 6.18 Electrical schematic-model 28169	10
Figure 6.19 Electrical schematic-model 28168 and 28155	11

1.1 Engine

Model No:	28169	28168	28155
Engine No:	21A977	285H77	31H777
Power - Hp	13	15.5	18
Fuel cap. - Litres	6.5 Litres		
Oil cap. - Litres	1.4 Litres		
			1.7 c/w filter
Oil grade	Refer to engine owner's manual		
Spark plug	RC 12YC		
Spark plug gap	0.7mm to 0.8mm		

1.2 Transmission

A single pedal variable speed drive system enabling either forward or reverse motion to be selected by activating a foot control pedal.

1.3 Cutterheads

760mm wide cut pressed steel cutterhead
 965mm wide cut pressed steel cutterhead

1.4 Tyres

Front- 13 x 5.00 x 6 tubed 140 KPa pressure
 Rear- 18 x 8.50 x 8 tubed 70 KPa pressure

1.5 Loose parts kit

Description	Quantity
Steering wheel	1
Roll pin	1
Stoneguard	1
Stoneguard spring	1
"E" clip	1
Ignition keys	2
Plug spanner	1
Pop Rivets	2
Engine Owners Manual	1
Rover Owners Manual	1

2. SETTING UP

2.1 Installing the steering wheel

- Slide the steering wheel over the steering shaft and align the roll pin holes.
- Insert a drift punch partially through the holes to maintain alignment and insert the roll pin.
- Drive the roll pin in until flush with the outside of the steering wheel.

2.2 Installing the stoneguard

- Slip the stoneguard spring on to the long leg of the stoneguard pivot rod.
- Twist the stoneguard spring and insert the long leg of the stoneguard pivot rod into the forward pivot bracket of the cutterhead.
- Slide the stoneguard back to insert the short leg of the stoneguard pivot rod into the rear pivot bracket of the cutterhead.
- Release the stoneguard spring.
- Fit the "E" clip to the groove on the short leg of the stoneguard pivot rod.

2.3 Installing the battery

- Remove the battery from the mower.
- Add 33% strength battery electrolyte to each cell of the battery until the plates are covered.

	CAUTION
Do not overfill the battery. Acid will overflow onto other parts of the machine and severe corrosion will result.	

- Charge the battery at 4 amps/hour for a minimum of 6 hours.**
- After charging check that the plates are covered by the electrolyte, if not, add electrolyte to the correct level.
- Refit the battery to the mower.
- Connect the battery leads to the battery. Red to the positive (+) terminal, black to the negative (-) terminal.

3.1 Throttle control (A)

Mounted on the left hand side of the dash panel. Marked for Slow, Fast and Choke positions. Figure 3.1.

3.2 Ignition switch (B)

Mounted on the right hand side of the dash panel. Marked for Off, On and Start positions. Figure 3.1.

3.3 Brake Clutch pedal (C)

Foot operated pedal mounted on the left hand side of the machine. Depressing the pedal disengages the drive and engages the disc brake. Figure 3.1.

3.4 Parking brake (D)

Hand operated knob mounted on the left hand side of the machine. Parking brake is locked on when the clutch brake pedal is depressed and the knob is engaged by lifting upward. Depressing the clutch pedal releases the parking brake. Figure 3.1.

3.5 Speed selection (E)

Foot operated pedal mounted on right hand side of the machine. Toe pressure for forward motion and heel pressure for reverse motion. Figure 3.2.

3.6 Cut height and Engagement lever (F)

Combined height adjustment lever located on the right hand side of the machine. Cutter is disengaged and the brake applied when the lever is pulled right back and engaged when moved forward. Marked with 8 positions from 15 to 65mm. Figure 3.2.

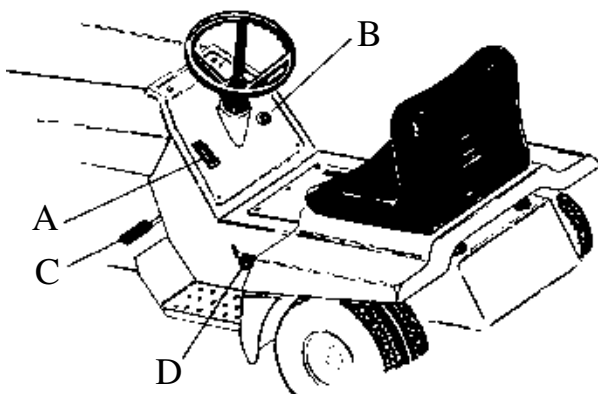

Figure 3.1 Dash panel and foot pedal

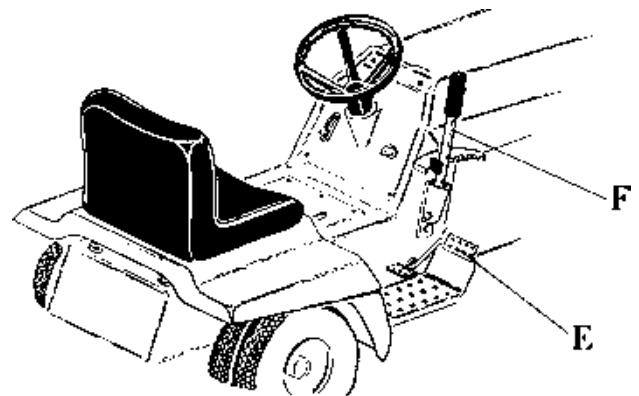

Figure 3.2 Foot and hand controls

3.7 Safety interlock system

The safety interlock system has been designed for the operators safety. It gives the Rover Rancher the following characteristics and should *NEVER* be tampered with.

The engine will not start unless ;

1. The cut height engagement lever is in the disengaged position.
2. The clutch brake pedal is depressed.

The engine will stop if the operator leaves the seat without first locking on the parking brake and disengaging the cutterhead.

	WARNING
<p>DO NOT operate the mower if the safety system becomes defective. Contact the nearest Rover authorised service dealer or agent to rectify the problem.</p>	

4.1 Engine lubrication

The engine oil level must be checked before attempting to start the engine. *Refer to the engine manufacturer’s instructions.*

1. Position the mower on a level surface. Open the bonnet and clean around the dip stick.
2. Remove the dip stick from the oil filler tube.
3. Using a funnel slowly add oil in accordance with the *engine manufacturer’s instructions.*
4. Check the oil level by screwing in the dip stick and removing again. When the oil level is correct replace the dip stick.

4.2 Fuel

1. Position the mower on a level surface in a well ventilated area. Open the bonnet and clean around the fuel tank cap.
2. Remove the fuel tank cap.
3. Using a clean funnel fill the fuel tank with **unleaded petrol**.
4. Replace the fuel tank cap.
5. Wipe up any spilt petrol.
6. Close and secure the bonnet.

4.3 Seat adjustment

1. Tip the seat forward and loosen the seat retaining bolts.
2. Slide the seat forward or back to suit the operator.
3. Tighten the seat retaining bolts and lower the seat.

 CAUTION
<p>Avoid premature engine failure by using a clean funnel and cleaning away any possible contaminants.</p>

5. OPERATION

5.1 To start the engine

1. Depress the clutch brake pedal.
2. Move the drive selector to neutral.
3. Disengage the cut height engagement lever.
4. Move the throttle lever to the choke position.
5. Turn the ignition key to the start position and release when the engine starts.
6. Move the throttle lever to the slow position.

5.2 To drive or mow

1. Depress the clutch brake pedal.
2. Move the throttle to the fast position.
3. Engage the cut height engagement lever and select the height of cut.
4. Select the desired speed to suit the conditions.
5. Slowly release the clutch brake pedal.

5.3 To stop the engine

1. Depress the clutch brake pedal.
2. Apply the parking brake.
3. Disengage the cut height engagement lever.
4. Move the speed selector to neutral.
5. Move the throttle lever to the fast position.
6. Turn the ignition key to the off position, and remove the ignition key before leaving mower. Place the key in a secure place not available to children or unauthorised persons.

5.4 Engaging clutches

When engaging the cutter drive lever or releasing the clutch brake pedal, **always operate slowly**. Do not use a jerking motion. Moving these controls too fast could possibly overload and stall the engine.

 CAUTION
<p>To avoid loss of control always come to complete stop before selecting speeds and slow down before turning.</p>

5.5 Cutterhead

1. Always remove the spark plug lead and disengage the cutter drive before working on the cutterhead.
2. Before using the mower always inspect the cutterhead to see that the cutting disc, blades and blades fasteners are not worn, loose or damaged.
3. Always check the cutterhead after striking a solid object. Never operate the mower when unusual vibration occurs.
4. Always replace blades in sets to preserve balance.
5. Remove any build-up of grass or clogging within the cutterhead.

6.1 Oil change

Refer to the engine manufacturer's instructions.

1. Position the mower on a level surface in a well ventilated area.
2. Start and run the engine for 5 minutes to warm up the engine oil.
3. Place a container under the oil drain channel on the right hand side of the chassis.
4. Using a 7/16" AF open end spanner remove the engine drain plug to allow the engine oil to drain completely.
5. Refit the engine drain plug and torque to 14.5Nm.
6. Fill the engine crankcase with oil, refer to section 4.1 Engine lubrication.

6.2 Lubrication points

Using general purpose grease.

1. Grease nipples on the steering shaft pivot block.
2. Cutterhead support plates.
3. Front axle beam.
4. Grease nipples on Front Stub Axles

Using 10w-30 or SAE30 oil

1. Jockey arm pivot.
2. Throttle control cable.
3. Clutch brake pedal pivot.
4. Tie rod ends.
5. Drive chains.

	CAUTION
Bearings are sealed for life and do not require lubrication.	

6.3 Wheel removal

Front wheels

	WARNING
Always deflate the tyre before removing rim nuts from the front wheel rims.	

1. Chock the rear wheels and remove the front wheel axle nut, using a 15/16" AF socket spanner.
2. Raise the front of the mower.
3. Slide the wheel off the axle.
4. Replace in reverse order and tighten the axle nut.

Rear wheels

1. Chock the front wheels and raise the rear of the mower.
2. Remove the four wheel rim nuts using a 9/16" AF socket spanner.
3. Slide the rear wheel off the wheel hub.
4. Replace the rear wheel to the wheel hub and retain using the four wheel nuts.
5. Tighten the wheel nuts and lower the mower to the ground.

6.4 Rear hub removal

1. Remove the rear wheel per section 6.3 (Rear Wheels)
2. Remove the Nyloc nut and Washer from the end of the axle shaft.
3. Slide the hub off the shaft with the aid of a puller. Never use a hammer.

6.5 Rear hub fitment.

1. Coat the axle shaft with 'Never-Seize' compound.
2. Place woodruff key in axle keyway and slide hub into position.
3. Replace the Nyloc Nut and Washer to the end of the axle shaft and tighten.

6.6 Steering gear adjustment

1. Loosen the two nuts under the chassis securing the steering shaft pivot block bolts (A). Figure 6.3
2. Move the steering shaft pivot block towards the layshaft and tighten the captive bolt nuts.
3. Check that there is no tight spots when turning the steering wheel from lock to lock. Readjust if necessary.

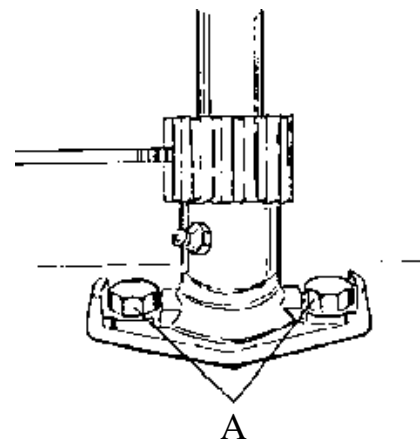

Figure 6.3 Steering pivot block

6.7 Cutterhead removal

1. Remove the spark plug lead from the spark plug and move the cutterhead to the low cut position.
2. Remove the cutterhead tension springs. Use a piece of wire hooked through the loop in the tension springs to assist in their removal.
3. Remove the engine pulley belt guard from around the engine pulley by removing the two 5/16" unc. retaining bolts, nuts and washers.
4. Remove the cutterhead drive belt by running it off the engine pulley.
5. Disconnect the cutterhead lift rod by removing the spring clip where it is connected to the cutterhead.
6. Remove the two front cutterhead support bolts (A) and lower the front of the cutterhead to the ground. Figure 6.4.
7. Remove the two rear cutterhead support bolts, (B), and lower the rear of the cutterhead to the ground.
8. Slide the cutterhead out from under the ride-on.

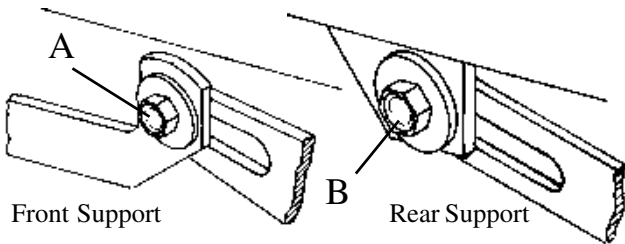

Figure 6.4 Cutterhead support plates

WARNING
Check operation of cutterhead brake after adjusting cutterhead level, tilt, and low cut setting.

6.8 Cutterhead Leveling

1. Place the ride-on, on a level dry surface, apply the parking brake and remove the ignition key.
2. Move the cut height engagement lever to the mid cut or desired cutting height.
3. Remove the two cutterhead springs.
4. Loosen the four cutterhead support bolts, allowing the cutterhead to slide to the bottom of the slots, and nip up the four bolts.
5. Raise the front right hand support bolt mid way in it's slot and tighten.
6. Fit the two cutterhead springs to the cutterdeck.
7. Measure the gap between the blade tip and the ground at the mid point of the cutterhead on one side, then rotate the cutterdisk 180° to measure the gap on the opposite side of the cutterhead, thereby using the same blade for measurement.
8. If it is found that the cutterhead is not level loosen off the front right hand support bolt and adjust accordingly.
9. Repeat step 7 and adjust if necessary.
10. Tighten all bolts.
11. It is also possible to adjust the level by independently adjusting the four cutterhead support bolts.

6.9 Cutterhead Tilt

760mm cutterhead - 15mm from front to back measured over the blade tips.

965mm cutterhead - requires no tilt.

Note: Use only one blade to check tilt by rotating the cutterhead disc 180°.

1. Place the ride-on on a dry level surface.
2. Move the cut height engagement lever to the mid cut position.
3. Measure the tilt of the cutterhead over the blade tips from front to back and check against measurements given.
4. Adjust the tilt of the cutterhead as required, by adjusting the two nyloc nuts located on the cutterhead conbars, maintaining a constant spring compression of 36mm measured from the front of the swivel block to the front of the nyloc nut (A). Figure 6.5.

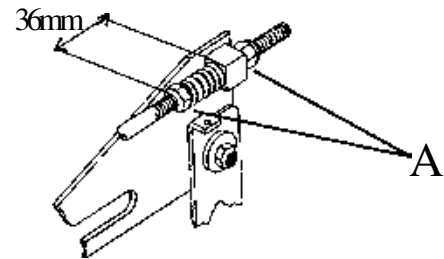

Figure 6.5 Cutterhead conbar

6.10 Cutterhead low cut setting

1. Position the machine on a level surface and disconnect the spark plug lead.
2. Move the cutterhead to the low cut position.
3. Adjust the nyloc nut (A) located on the cutterhead lift rod to give a low cut of 15mm measured at the front of the blade tip circle. Figure 6.6.

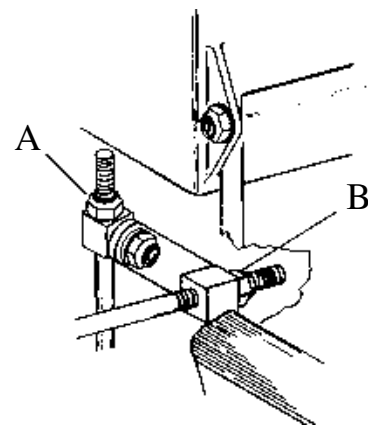

Figure 6.6 Cutterhead Lift rod

6.11 Cutterhead disengagement

1. Move the cut height engagement lever to the high cut position.
2. Adjust the nyloc nut (B) Figure 6.6 on the engagement rod till the rollers on the cutterhead engagement arms contact the ramps on the front cutterhead supports arms. Figure 6.7.

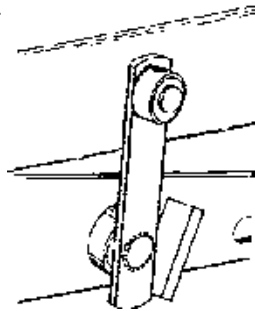

Figure 6.7 Engagement Rollers

6.12 Cutterhead brake adjustment

1. Move the cutterhead to the high cut position.
2. Loosen the two bolts retaining the brake plate and adjust the position of the brake plate to give 3mm clearance between the brake pad and the cutterhead pulley.
3. Move the cutterhead to the disengaged position to check operation of the brake.
4. Start the engine and move the throttle to the fast position, engage the cutterhead and wait till the cutterhead obtains full speed.
5. Move the cut height lever to the disengaged position and time the time taken for the cutterhead disc to come to a stand still. The cutterhead disc should stop spinning within seven seconds.
6. If the cutterhead disc takes longer than seven seconds readjust the position of the cutterhead brake plate closer to the cutterhead pulley and recheck as in points 4 and 5.

6.13 Cutterhead brake pad replacement

1. Remove the brake plate by removing the two retaining bolts on the side of the chassis for the 760mm cutterhead or remove the brake plate fitted to the top of the cutterhead on the 965mm cutterhead.
2. Drill out the two retaining rivets which hold the Brake pad assembly to the spring plate and discard the old brake pad backing plate.
3. The replacement brake pads are fitted with a chemically bonded backing plate, locate this backing plate against the spring plate and retain with two 3/16" rivets. Part No: A2901195.
4. Replace the brake plate to the ride-on and check the operation of the cutterhead brake as in section 6.12 Cutterhead brake adjustments.

6.14 Brake caliper adjustment

1. Loosen the locknut (A). Figure 6.8.
2. Adjust the bolt (B) so that the brake caliper (C) contacts the disc brake.
3. Tighten the locknut (A) and check operation of the brake.

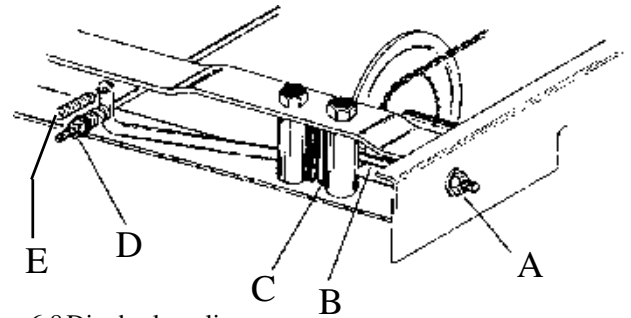

Figure 6.8 Disc brake caliper arms.

6.15 Brake arm adjustment

1. Adjust the brake caliper as set out in section 6.14
2. Adjust the nyloc nut (D) on the brake rod so that the brake arm contacts the brake disc. Figure 6.8.
3. Check that the park brake can be applied, and that the brake operates correctly.

6.16 Auto-Drive unit removal

1. Chock the front wheels of the ride-on.
2. Remove the two cutterhead springs.
3. Remove the brake rod return spring (E) Figure 6.8.
4. Remove the brake rod nyloc nut (D) from the brake rod. Figure 6.8.
5. Remove the brake rod spring clip at the brake clutch pedal and remove the brake rod from the pedal then remove the brake rod from the ride-on.
6. Remove nut (A) securing neutral rod bracket to neutralising arm. Figure 6.15.
7. Remove engine belt tension spring from jockey arm.
8. Remove the spring clip retaining the engagement rod to the engagement arm and remove the engagement rod. This is visible through the slot in the side of the chassis.
9. Remove the two top alignment bolts and washers (A) from near the top of each side of the chassis. Figure 6.9.
10. Remove the three retaining bolts (B) from each side of the chassis's bottom flange. Figure 6.9.
11. Remove the six inspection panel retaining screws and remove the inspection panel to reveal the input pulley.
12. Push the Auto-Drive unit forward and remove the input drive belt from the Auto-Drive input pulley.
13. Raise the rear of the ride-on until it is possible to remove the Auto-Drive unit.
14. Replace in the reverse order.

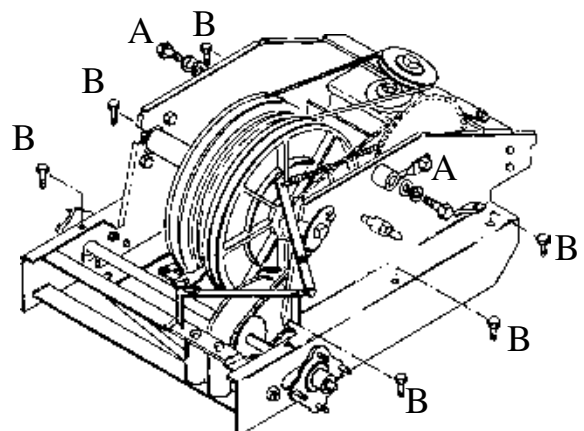

Figure 6.9 Auto-Drive unit

6.17 Auto belt tensioner

The continuous drive belt is kept under constant tension by the Auto belt tensioner. This is set up initially at the factory and should not need attention unless the drive belt has stretched past its serviceable life, indicated when the spring finger (A) is engaged in the red area on the rack assembly (B). Figure 6.11.

6.18 Drive belt removal

1. Hook a piece of wire through the end loop of the auto-adjuster spring Figure 6.10
2. Pull back on the piece of wire and disengage the auto adjuster spring from the spring plate.
3. Remove neutralising arm pivot bolt (C) Figure 6.15.
4. Disengage the spring finger from the rack and remove the drive belt from around the pulleys and discard.

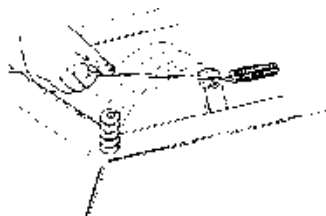

Figure 6.10 Belt tensioner spring plate

6.19 Drive belt installation

1. Place the drive belt around the drive pulleys, return pulley and idler pulley.
2. Place the peg on the rack assembly (C) into the middle slot of the cam plate assembly (D). Figure 6.11.
3. Draw the spring back into position using a piece of wire and hook into the spring plate. Check that the spring finger (A) engages in the first couple of teeth on the rack assembly (C). Figure 6.11.

If the spring finger engagement in the rack assembly is not at the start of the rack assembly, proceed as follows;

4. Release the spring plate as per section 6.18.
5. Loosen the pivot bolt (E) and slide the cam plate assembly (D) forwards. Figure 6.11.
6. Tighten the pivot bolt (E) figure 6.11 and repeat step 3.
7. Replace neutralising arm.

Note:- Pivot Bolt 'E' is mounted in a slot.

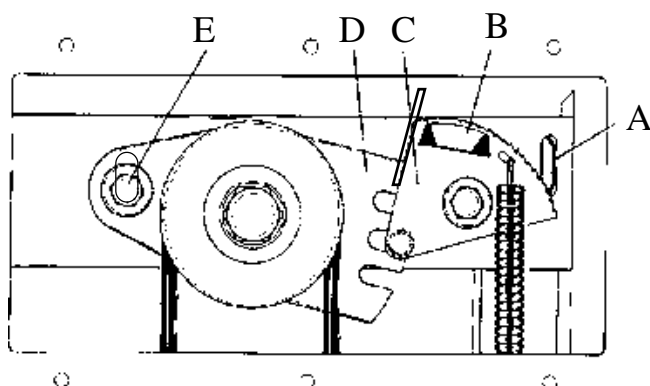

Figure 6.11 Auto-Belt tensioner

Note:

After a period of time the drive belt will stretch past the limit of the auto belt tensioner. The auto belt tensioner can be reset to allow for this stretching by following the steps 4 to 6 section 6.19. Re-grease the bearing area under the cam plate and pivot (E) when fitting a new drive belt. Figure 6.11.

6.20 Primary drive chain adjustment

Note: After checking the tension of the primary drive chain the secondary drive chain should be checked.

1. Loosen the idler sprocket pivot bolt (A). Figure 6.12.
2. Slide the idler sprocket forward to tension the primary drive chain.
3. Tighten the idler sprocket pivot bolt (A) and rotate the primary drive chain to check for tight spots.

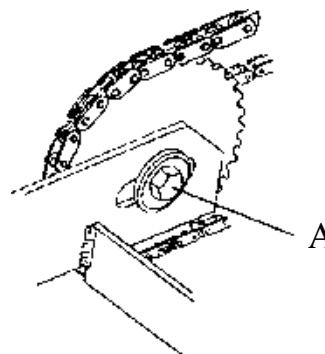

Figure 6.12 Primary drive chain

6.21 Secondary drive chain adjustment

Note: Before adjusting the secondary drive chain tension check and adjust if necessary the primary drive chain.

1. Loosen the Jockey sprocket pivot bolt (A) figure 6.13.
2. Slide the Jockey sprocket towards the chain to take up slack and tighten the Jockey sprocket pivot bolt.
3. Rotate the secondary drive chain and check for tight spots. Readjust if tension is not correct.

CAUTION
Do not over tension the drive belts or drive chains.

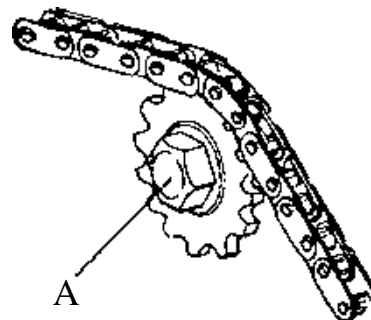

Figure 6.13 Secondary drive chain adjustment

6.22 Drive selector pedal adjustment

The drive selector pedal angle can be adjusted either forward or back to suit the individual operator requirements.

1. Loosen the two retaining bolts (A) on the drive selector pedal bracket. Figure 6.14.
2. Slide the drive selector pedal bracket either forward or backwards to attain the required drive pedal angle.
3. Tighten the two retaining bolts (A) on the drive selector pedal bracket and check the operation of drive selector pedal.

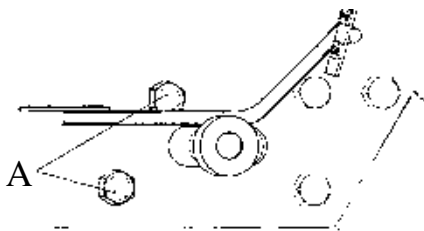

Figure 6.14 Drive selector pedal

6.23 Autodrive Engine Belt

This belt is constantly tensioned and no adjustment is required.

6.24 Autodrive engine belt replacement

1. Remove spark plug lead from spark plug and lower the cutterhead to the low cut position.
2. Remove cutterhead tension springs. Use a piece of wire hooked through the loop in the tension springs to assist in their removal.
3. Remove engine pulley belt guard from around the engine pulley by removing the two 5/16" unc. retaining bolts, nuts and washers.
4. Remove the cutterhead drive belt by running it off the engine.
5. Remove the six inspection panel retaining screws and remove inspection panel on top of the chassis.
6. Remove tension spring from jockey arm.
7. Remove worn belt.
8. Replace in reverse order.

6.25 Autodrive neutralising adjustment

1. Depress the brake clutch pedal (C in Figure 3.1), release the parking brake and release pedal.
2. Loosen bolt (B) and move bolt and bearing in slot to centralise drive assembly in neutral position and re-tighten bolt. Figure 6.15.
3. Check operation to ensure adjustment is correct.

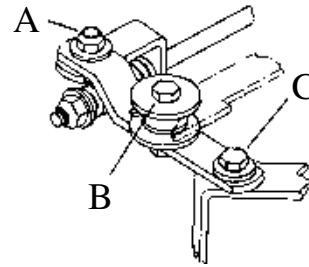

Figure 6.15 Autodrive neutralising adjustment

6.26 Safety Interlock adjustment

Clutch brake safety switch

1. Depress the clutch brake pedal and lock parking brake on.
2. Loosen the spring tab retaining bolt (A) and adjust the position of the spring tab located on the park brake rod, to give a clearance of 6mm between the safety switch body and the spring tab. Figure 6.16
3. Tighten the spring tab retaining bolt.

Cutterhead safety switch

1. Move the cut height engagement lever to the engaged position.
2. Loosen the two safety switch retaining screws (A) and position the safety switch forward in the mounting bracket slot. Figure 6.17.
3. Tighten the two safety switch retaining screws.
4. Move the cut height engagement lever to the disengaged position.
5. Check that the clearance between the spring tab (B) and the safety switch body is 6mm. If not correct loosen the retaining bolt (C) and position the spring tab to give correct clearance. Tighten the spring tab retaining bolt. Figure 6.17

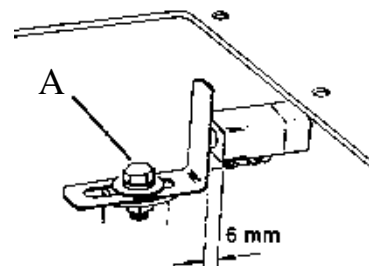

Figure 6.16 Clutch brake safety switch

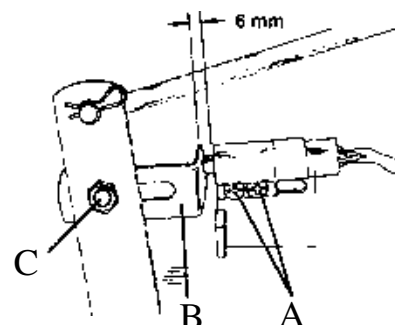

Figure 6.17 Cutterhead safety switch.

6.27 Front Axle Beam

Periodically clean and grease the front axle beam pivot area on ride-on chassis. Do not overtighten the two front beam bolts. Beam must be free to pivot in chassis.

6.28 Maintenance Chart

This maintenance chart is to be read in conjunction with the engine manufacturer's instruction manual and information in this Owner's manual

Engine	Frequency						
	Each use	First 5 hours	First 20 hours	Every 25 hours	Every 50 hours	Every 100 hours	Every 200 hours
Check oil level	x						
Change oil		Briggs	Honda		Briggs (i)	Honda (i)	
Change oil filter (if fitted)						x	
Check air filter elements	x						
Clean air filter foam element				x (ii)			
Clean air filter paper element				x (ii)			
Replace air filter paper element							x (ii)
Check air intake screen	x						
Check spark plug					x		
Replace spark plug						x	
Check battery fluid level	x						
Clean battery & terminals				x			
Replace fuel filter						x	
Ride-On							
Check safety interlocks				x			
Check cutting blades	x (iii)						
Check cutterhead brake				x			
Check disc brake				x			
Check drive belts				x			
Check tyre pressure	x						
Remove and clean under pulleys covers. 38" deck only					x		
Check for loose fasteners	x						
Lubrication points							
	Type of lubricant						
Oil jockey arm pivot		Engine oil		x			
Oil throttle cable		Engine oil		x			
Oil cutter drive lever		Engine oil		x			
Oil clutch/brake pedal		Engine oil		x			
Oil tie rod ends		Engine oil		x			
Oil drive chains		Chain oil		x			
Grease stub axles		GP grease		x			
Grease axle beam		GP grease		x			
Grease steering shafts		GP grease		x			

Notes:

- i - Change the oil every 25 hours when operating the engine under heavy load or in high temperatures refer to engine manufacturer's instruction manual for correct grade of oil.
- ii - Clean the air filter elements more often under dusty conditions or when air borne debris is present. Replace air cleaner parts, if dirty.
- iii- Always replace cuttings blades in sets to maintain balance

	WARNING
Before undertaking any maintenance, cleaning or adjustments, apply the parking brake and remove the ignition key.	

6.29 Electrical system- 13HP

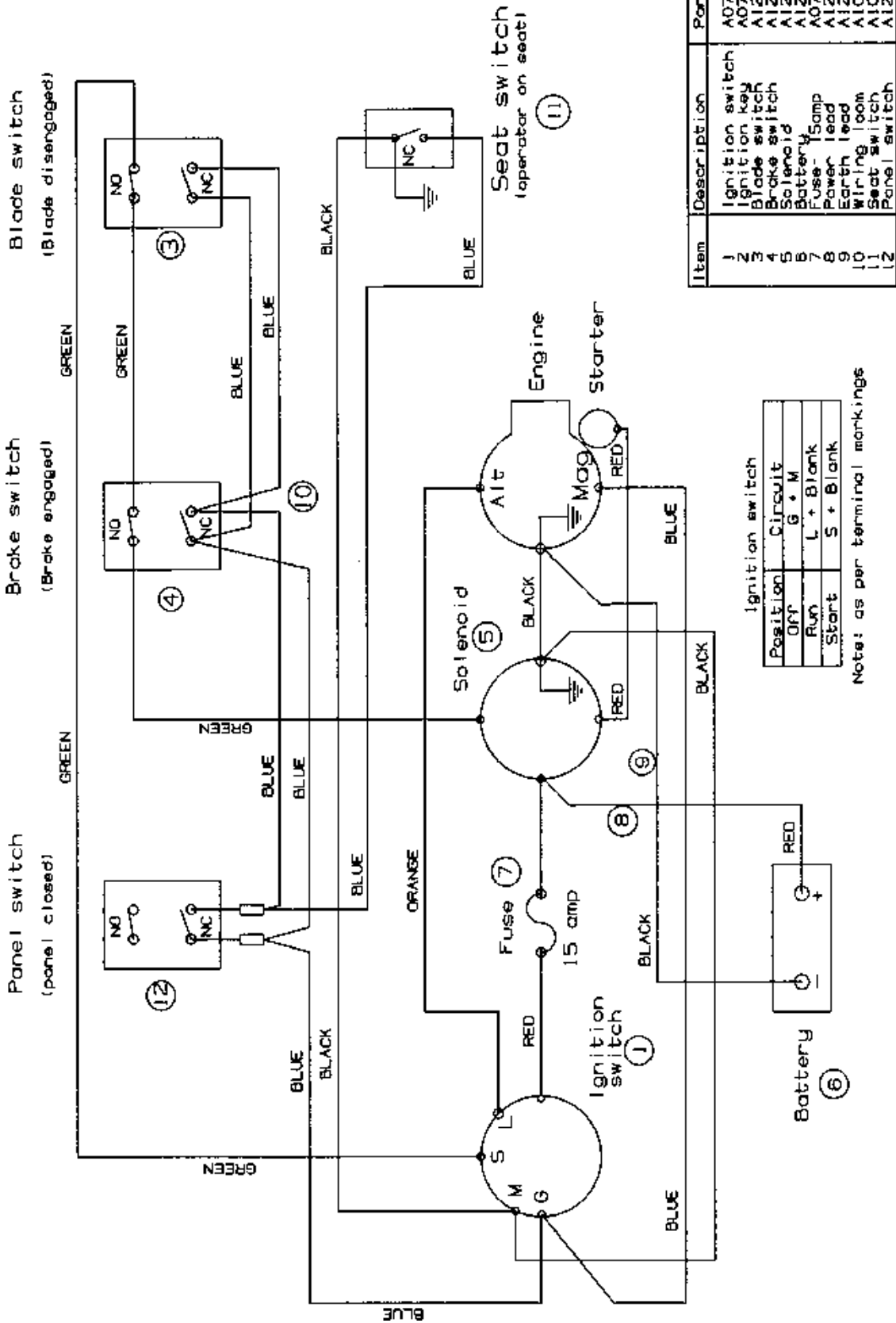

Item	Description	Part No.
1	Ignition switch	A07678
2	Ignition key	A07679
3	Blade switch	A12764
4	Brake switch	A12764
5	Solenoid	A12586
6	Battery	A12017
7	Fuse - 15amp	A07513
8	Power lead	A12747
9	Earth lead	A12748
10	Wiring loom	A10516
11	Seat switch	A10257
12	Panel switch	A12764

Position	Circuit
Off	G + M
Run	L + Blank
Start	S + Blank

Note: as per terminal markings

SPV- 59	Sheet: 8
Rev. A	7 April 2004
Model: Rancher Auto-Drive	
Page:	

Electrical schematic- model 2B169 Rancher 13 Hp OHV AVS

6.30 Electrical system - 15.5 and 18HP - Ranchers

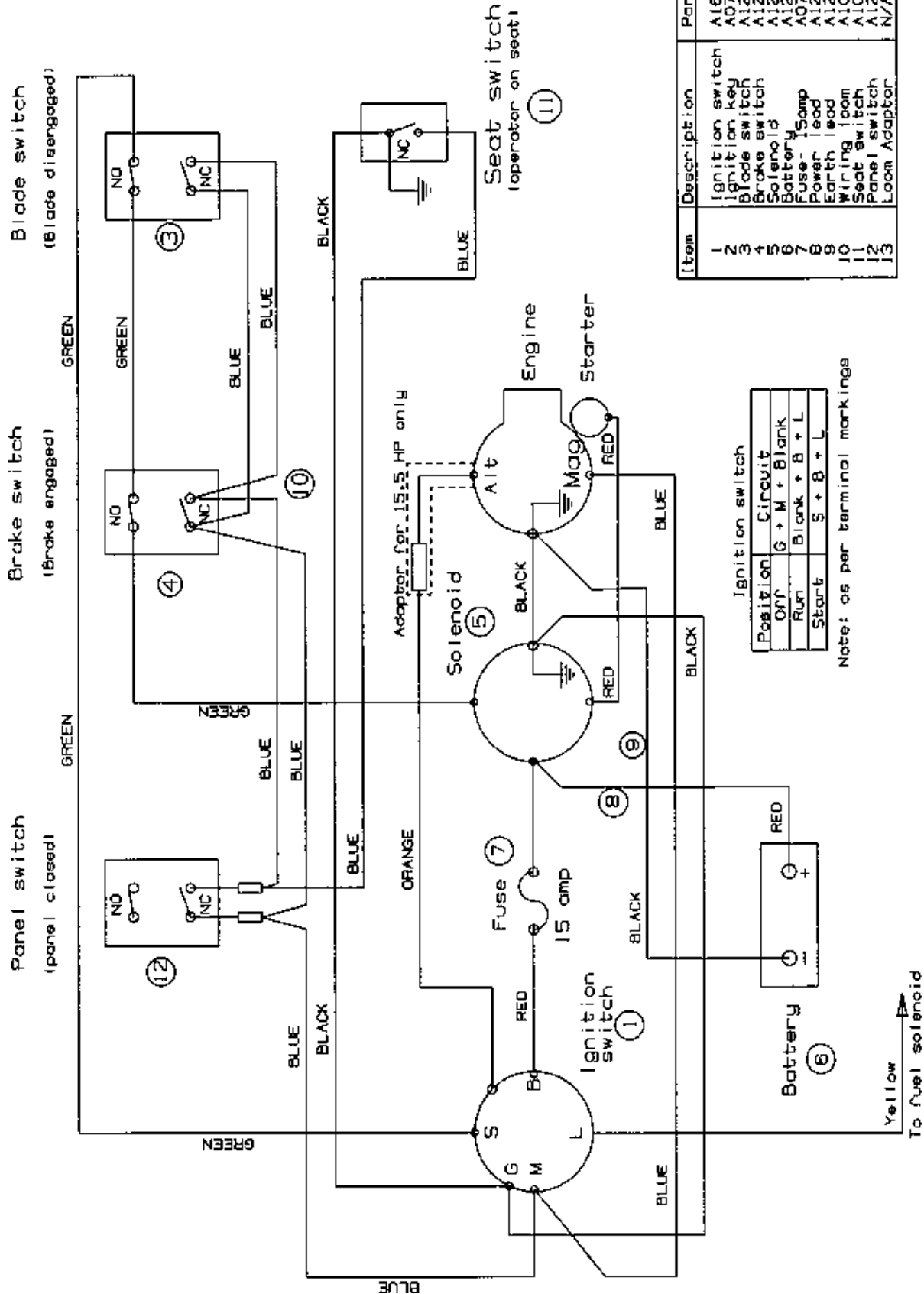

Item	Description	Part No:
1	Ignition switch	A16110
2	Ignition key	A07679
3	Blade switch	A12764
4	Brake switch	A12764
5	Solenoid	A12596
6	Battery	A12017
7	Fuse - 15amp	A07513
8	Power lead	A12747
9	Earth lead	A12748
10	Wiring loom	A10723
11	Seat switch	A10257
12	Panel switch	A12764
13	Loom Adaptor	N/A

Position	Circuit
OFF	G + M + Blank
Run	Blank + B + L
Start	S + B + L

Note: as per terminal markings

SPV - 59	Sheet: 9
Rev. A	7 April 2004
Model: Rancher Auto-Drive	
Page:	

Electrical schematic - made | 28158 Rancher 15.5 Hp Intek
 made | 28155 Rancher 18 Hp Intek

TROUBLE SHOOTING

PROBLEM	POSSIBLE CAUSES	CORRECTIVE ACTION
Engine loses power.	<ol style="list-style-type: none"> 1. Oil level in crankcase is low. 2. Cooling fins and air passages under engine blower housing are blocked. 3. Engine load is excessive. 4. Air cleaner is dirty. 5. Dirt or water is in fuel system. 6. Carburettor is adjusted incorrectly. 7. Spark plug is pitted, fouled or defective in some other way. 	<ol style="list-style-type: none"> 1. Add oil to crankcase. 2. Remove obstruction from passages. 3. Select a lower speed to reduce load. 4. Clean air cleaner element. 5. Have machine serviced by Authorised Service Dealer. 6. Adjust the carburettor. 7. Install new correctly gapped spark plug.
Engine over heats.	<ol style="list-style-type: none"> 1. Cooling fins and air passages under engine blower housing are blocked. 2. Carburettor is adjusted incorrectly. 3. Oil level in crankcase is low. 4. Engine load is excessive. 	<ol style="list-style-type: none"> 1. Remove obstruction from cooling fins and air passages. 2. Adjust the carburettor. 3. Add oil to crankcase. 4. Select a lower speed to reduce load.
Mower vibrates abnormally.	<ol style="list-style-type: none"> 1. Engine mounting bolts are loose. 2. Loose cutter pulley, idler pulley or drive pulley. 3. Cutter assembly is unbalanced. 4. Cutter assembly is loose. 	<ol style="list-style-type: none"> 1. Tighten mounting bolts. 2. Tighten the appropriate pulley. 3. Replace broken blades in sets. 4. Tighten securing nut.
Cutter does not rotate.	<ol style="list-style-type: none"> 1. Cutter drive belt is worn, loose or broken. 2. Cutter drive belt is off pulley. 	<ol style="list-style-type: none"> 1. Install new cutter drive belt. 2. Install cutter drive belt.
Mower does not drive.	<ol style="list-style-type: none"> 1. Drive belt is worn, loose or broken. 2. Drive belt is off pulley. 3. Unable to select forward or reverse. 	<ol style="list-style-type: none"> 1. Install new drive belt. 2. Install drive belt. 3. Have machine serviced by Authorised Service Dealer.
Engine does not start, hard to start, loses power, or fails to keep running.	<ol style="list-style-type: none"> 1. Fuel tank is empty. 2. Speed selected. 3. Cutter Drive is engaged. 4. Spark plug is loose. 5. Spark plug lead is loose or disconnected from spark plug. 6. Spark plug gap is incorrect. 7. Spark plug is pitted, fouled or defective in some other way. 8. Wrong spark plug is used. 9. Electrical connections are loose. 10. Carburettor is adjusted incorrectly. 11. Air cleaner is dirty. 12. Vent hole in fuel tank is blocked. 13. Dirt or water in fuel system. 14. Dead battery. 15. Defective Electronic Ignition System. 16. Defective Safety Switches. 	<ol style="list-style-type: none"> 1. Fill fuel tank with petrol. 2. Select Neutral. 3. Disengage Cutter Drive. 4. Tighten spark plug. 5. Install spark plug lead on spark plug. 6. Set gap between electrodes at 0.7mm to 0.8mm. 7. Install new correctly gapped spark plug. 8. Install correct spark plug. 9. Check electrical system to ensure good contact. 10. Adjust the carburettor 11. Clean the air cleaner element. 12. Inspect and open vent. 13. Have machine serviced by Authorised Service Dealer.
Engine does not idle or idles poorly	<ol style="list-style-type: none"> 1. Air cleaner is dirty. 2. Oil level in crankcase is low. 3. Cooling fins and air passages under engine blower housing are blocked. 4. Idle speed is too low or high 5. Dirt or water is in fuel system. 6. Vent hole in fuel tank is blocked. 7. Spark plug is pitted fouled or defective in some other way. 	<ol style="list-style-type: none"> 1. Clean air cleaner element. 2. Add oil to crankcase. 3. Remove obstruction from cooling fins and air passages. 4. Adjust the carburettor. 5. Have machine serviced by Authorised Service Dealer. 6. Clean fuel tank vent. 7. Install new correctly gapped spark plug.

WARRANTY

General

- Rover Mowers Limited warrant this machine or accessory is free of defects in material and workmanship.
- Claims are limited to making good or replacing any part found defective by the manufacturer or his agent.
- The warranty period shall apply from the date of purchase for a period of:
 - 12 months for domestic use
 - 90 days for commercial use
- Warranty applies to Australia and New Zealand only.

EXTENDED WARRANTY: For domestic use only, a 24 month extended warranty applies. It requires the customer to complete the '2 Year warranty registration card', and forward along with a copy of the cash register receipt to "Warranty, Rover Mowers Limited". Normal warranty exclusions as listed still apply.

Exclusions

A list of conditions excluded from warranty follows:



- Engines other than Suzuki products.
- Parts considered suffering from wear and tear.
- Parts damaged due to abuse or misuse.
- Parts that can be subjected to use beyond their normal intended working capacity e.g. blades, blade bolts, v-belts and spark plugs.
- If repairs or alterations have been made without the manufacturer's written authority.
- Any transport costs involved in the repair or replacement of any defective part.
- If it is found that parts other than genuine have been used on the machine.

NB This warranty does not exclude any conditions or warranty implied by the Trade Practices Act 1974 or any other relevant legislation.

Engines other than Suzuki are warranted by the engine manufacturer and could differ from the warranty of the rest of the machine.

Refer to the engine manual (if included) or consult the nearest engine service dealer.

Proof of date of purchase should be retained as it needs to be presented if warranty is to be claimed. Fill out the details in the following table as a record for warranty purposes.

Dealer	Product
• Name:	• Model number:
• Address:	• Serial number:
• Phone No:	• Date of purchase:



Rover Mowers Limited reserves the right to make changes and add improvements to its products at any time without notice or obligation. The company reserves the right to discontinue manufacture of any product at any time to its discretion.



Rover Mowers Limited
PO Box 1235
Eagle Farm
Queensland 4009
AUSTRALIA

Rover Mowers Limited
East Tamaki
Auckland
NEW ZEALAND



Printed in Australia on RECYCLED PAPER as a sign of Rover Mower's commitment to greening Australia and New Zealand.

Free Manuals Download Website

<http://myh66.com>

<http://usermanuals.us>

<http://www.somanuals.com>

<http://www.4manuals.cc>

<http://www.manual-lib.com>

<http://www.404manual.com>

<http://www.luxmanual.com>

<http://aubethermostatmanual.com>

Golf course search by state

<http://golfingnear.com>

Email search by domain

<http://emailbydomain.com>

Auto manuals search

<http://auto.somanuals.com>

TV manuals search

<http://tv.somanuals.com>