

Owners Manual

QUEENTM **30" REEL MOWER**



SAFETY INSTRUCTIONS

- * A mower user must be in good physical condition and mental health and not under the influence of any drug or alcohol which might impair vision, co-ordination or judgement.
 - * Do not use a mower when tired or fatigued. Lack of alertness may cause serious injury.
 - * Know your controls. Read and Understand Owner's Manual before operating mower. Learn how to stop the mower in an emergency. Refer to Operator's Instructions.
 - * Do not lend or sell the mower without the Owner's Manual.
 - * Be sure that anyone using the mower reads and fully understands how to safely operate the mower.
 - * Never mow whilst bystanders or pets are present in the mowing area.
 - * Never mow while barefoot or wearing open sandals or thongs. Wear long trousers and heavy non-slip shoes.
 - * It is advisable to wear suitable eye protection when operating a mower.
 - * Before using, always visually inspect to see that the blades, blade bolts and cutter assembly are not worn or damaged. Replace worn or damaged blades and bolts in sets to preserve balance.
 - * Damaged blades and worn bolts are major hazards.
 - * Replace worn or faulty silencers.
 - * Make sure the area to be mowed is cleared of sticks, stones, bones, wire and debris. They could be thrown by the blades.
 - * Store fuel in a cool place in a container specifically designed for the purpose. In general, plastic containers are unsuitable. Handle fuel carefully. It is highly flammable.
 - * Refuel outdoors only. Do not smoke when refuelling engine. Add fuel before starting engine. Never remove the cap from the fuel tank or add petrol while engine is running. Allow engine to cool for several minutes before refuelling if engine is hot. If petrol is spilled, do not attempt to start the engine, but move the mower away from the area of the spill and avoid creating any source of ignition until the petrol vapours have dissipated.
 - * Remove the fuel cap slowly to relieve fuel tank pressure.
 - * Check for fuel leaks while refuelling or using the mower. If fuel leak is found, do not start or run the engine until the leak is fixed and spilled fuel is wiped away.
 - * Take care not to get fuel on your clothing. If this occurs, change your clothing immediately.
 - * Do not operate mower in confined space where exhaust fumes (carbon monoxide) can collect.
 - * Mow only in good daylight.
 - * Start the engine carefully with feet well away from the blades.
 - * Disengage all blade and drive clutches before starting.
 - * When starting, do not wrap the starter rope around your hand. Do not allow the starter cord to snap back. Return the starter grip slowly to allow the cord to rewind properly.
 - * Strictly follow the operator instructions before attempting to start engine.
 - * Never leave wind-up starters in a wound position.
 - * Never mow where machine could tip or slip.
 - * On slopes or wet grass be extra careful of your footing.
 - * Never cut grass by pulling mower towards you.
 - * Be extremely careful when using a mower on slopes. Stay alert for holes in the terrain and other hidden hazards.
 - * Stop the engine before pushing the mower across gravel drives, walks or roads.
 - * Never over-speed the engine or alter the governor settings. Excessive speed is dangerous and shortens mower life.
 - * Stop the engine whenever you leave the mower even for a moment.
 - * Stop the engine and disconnect the spark plug wire and inspect mower if:
 - (a) The mower begins to vibrate abnormally; or
 - (b) After striking a foreign object.
- Repair any damage before continuing further operation of the mower.
- * Stop the engine and disconnect the spark plug wire before clearing blockages, checking or working on the mower.
 - * Never pick-up or carry a mower when it is operating.
 - * Where fitted, turn fuel tap off at the conclusion of the mowing.
 - * When transporting in a vehicle, secure the mower to prevent movement, roll-over, fuel spillage, and mower damage.
 - * Keep all nuts, bolts and screws tight to be sure the equipment is in a safe working condition.
 - * Never modify the mower in any way. Use only replacement parts made and guaranteed by the original manufacturer of your mower.
 - * Keep all safety devices (guards and switches) in place and working.
 - * Keep the engine free of grass, leaves or excessive grease – these can be a fire hazard.
 - * Store the mower in a well ventilated room away from naked flames such as may be found in hot water heaters.
 - * Walk, Never Run.
-
- To emphasise special information the words **WARNING** and **CAUTION** are used.
- WARNING:** The safety of the user and others is involved. Personal injury may result should this information be disregarded.
- CAUTION:** Follow these instructions carefully to avoid mower damage and loss of warranty.

MAINTENANCE AND ADJUSTMENT

30" QUEEN™ ELECTRIC MOWER 2 SPEED OPERATION

Normal Speed _ 4.9km/p.h 127 cuts per metre.
Low Speed _ 3.2km/p.h 183 cuts per metre.

SPEED CONTROL

To change speed, stop motor and move ribbed sliding sleeve (A) inwards to engage normal speed or outwards for low speed as required. It may be necessary to twist the sleeve or countershaft backwards and forwards slightly whilst sliding the sleeve position to allow the gear teeth to line up and mesh fully.

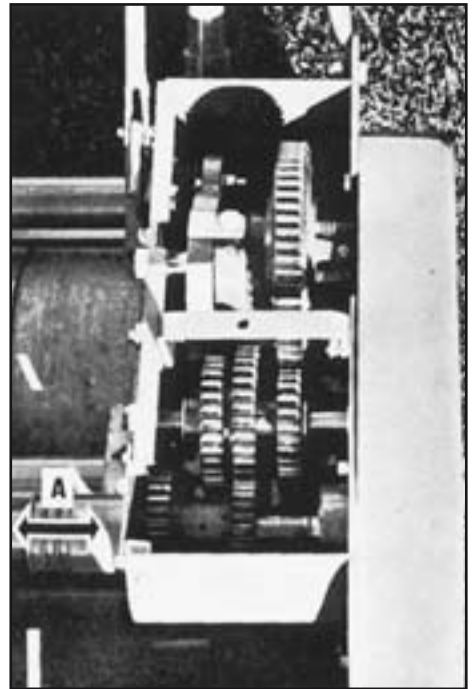

FRONT ROLLER – *The height of the cut of the Mower is controlled by the adjustment of the front roller. The machine cuts lower if the front roller is raised, or alternatively, the machine cuts higher if the front roller is lowered.*

WARNING

Model 300433 415 volt 3 phase Queen™ mower

Before use the rotation of the electric motor mounted on the Queen™ mower has to be checked for the correct direction of rotation with the local power supply to be used. This is at the onus of the purchaser and must be completed by a qualified electrician.

Use extreme caution when performing the following inspection due to exposed rotating parts.

1. With the power supply disconnected remove the motor cover and disengage all clutches.
2. Connect the power supply to the mower.
3. Switch the power on.
4. Move to the right hand side of the mower and note the direction of rotation of the motor pulley when looking directly at the end of the motor shaft. It should be rotating in the clockwise direction (left to right). Switch the motor off and disconnect the power supply.
5. If the direction of rotation of the motor is correct replace the motor cover and proceed to use the mower. If the direction of rotation of the mower shaft is incorrect contact a qualified electrician to have the motor rotation reversed to suit your power supply.

HEIGHT ADJUSTMENT – To cut lower, slacken quadrant clamp bolt nuts (1), also the lower adjusting screw nut (2). Then tighten top adjusting screw nut (3) until desired height of cut is obtained. To cut higher, reverse procedure. Re-tighten all nuts after desired setting is obtained. The indicator marks on the quadrant are an indication of the cutting height, but to set the height of cut accurately the setting gauge must be used. Refer setting gauge instructions.

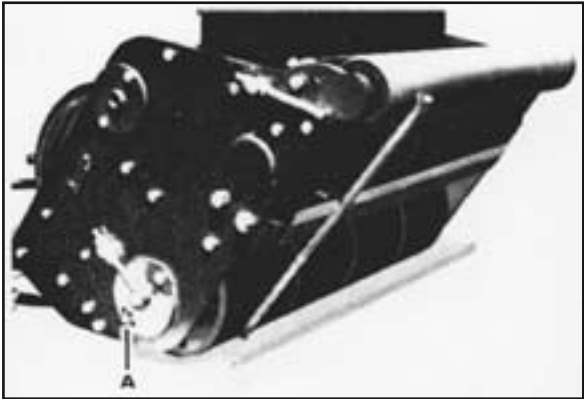
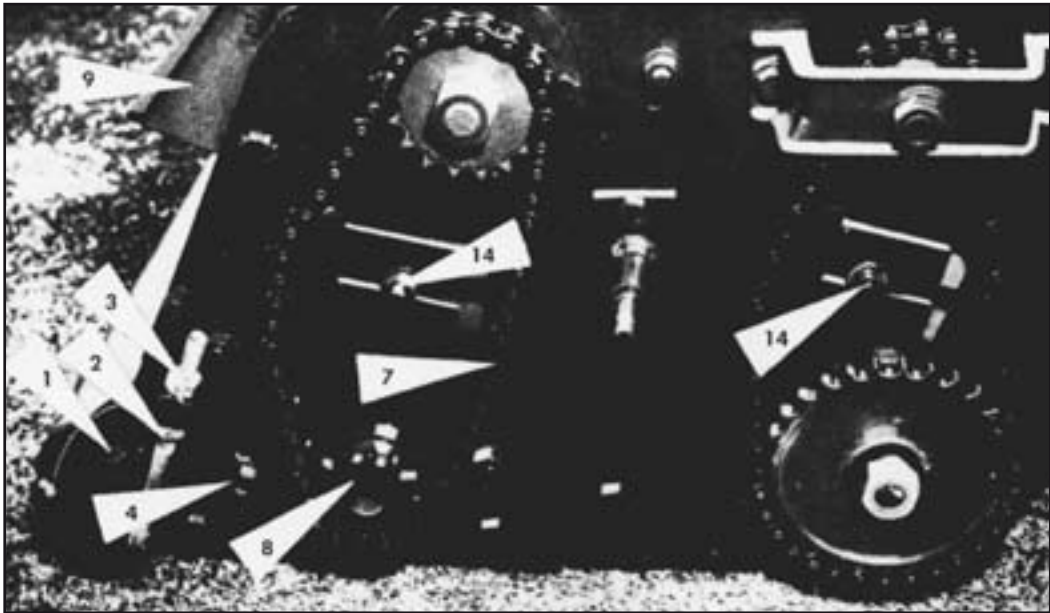

SETTING GAUGE – This illustrates the method of setting the gauge to the height of cut, where in this instance height of cut is a twenty cent piece and a five cent coin. The distance between the setting gauge bar and the underside of the adjustable screw head represents the height of cut. Lock the screw in the desired position with the wing nut. To use the setting gauge, rest it against the underside of the front and rear rollers, as illustrated, and by adjusting the front roller, the desired height of cut will be obtained when the underside of the screw head lightly touches the top cutting edge of the bottom blade across its full width. When using the setting gauge, take care not to force the head of the adjusting screw onto the bottom blade, as this could distort the blade and affect the setting.

TO CHECK THE MOWER FOR ALIGNMENT – Your mower is designed to produce the perfectly flat cut that is required for a top quality green. Ridging or stepping between cuts means that the height of cut is unevenly set or more likely, that the mower is “out of square” – That is, the rear roller is not perfectly in line with the cutting edge of the bottom blade. This condition can be brought about by transport of the mower or undue stress caused by bumping while moving from the equipment shed onto the green. Re-alignment can be achieved by different means but the recommended procedure is –

Lay the mower back on the handle.

Chalk the thin front edge of the bottom blade about 6” of its length at both ends.

With the front roller remaining in approximately its normal height setting, “sight” the bottom of the front roller relative to the chalked cutting edge of the blade.

Adjust the front roller into exact alignment with the cutting edge, continually sighting while adjustment proceeds.

Lock the roller and recheck.

Now use your height setting bar as an aligning tool by placing the bar against the front roller and the rear roller on the extreme LEFT HAND SIDE. (Chain Cover Side)

Adjust the setting bar screw so that it just contacts the bottom blade cutting edge.

Test the right hand side of the rollers with the same setting, and adjust the rear roller up or down until the same screw contact is achieved on the blade.

As the movement of the rear drum could affect the original L.H.S. setting slightly, reset the screw at the L.H.S. and recheck the R.H.S.

All elements of your machine will not be in perfect alignment.

After tightening all adjustments a final check should be made.

The required height of cut can now be checked and set in the normal manner.

While the procedure may seem complicated it is in fact very simple to perform and can be carried out in less than 15 minutes. The sighting is easy and accurate because it is done from the front roller which is nearest to the operator. A machine that is “true” will pay dividends by precision cutting of your green.

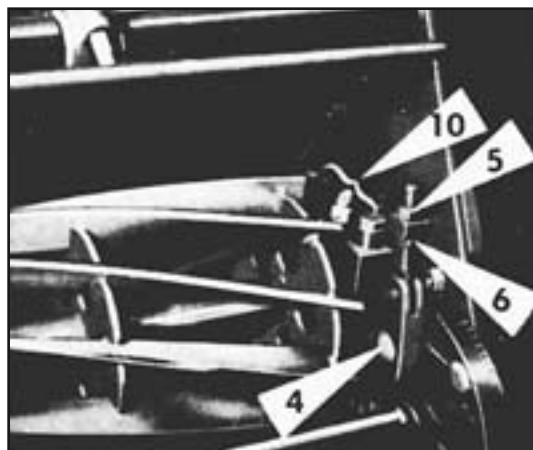

CUTTER – To adjust the cutter setting, slacken cutter hanger clamp bolts (4) at each side of the machine, and proceed as follows:

Adjustment – Slacken the top nuts (5) on adjusting screws. Then by tightening the bottom nuts (6), the cutter is lowered on to the bottom blade. To raise the cutter, loosen the bottom nuts and tighten the top nuts. Re-tighten cutter hanger clamp bolt nuts. Always adjust cutter to bear very lightly on bottom blade. If the cutter rubs harshly on the bottom blade, there will be excessive wear of both cutter blades and bottom blade, and an unnecessarily heavy load on the power unit.

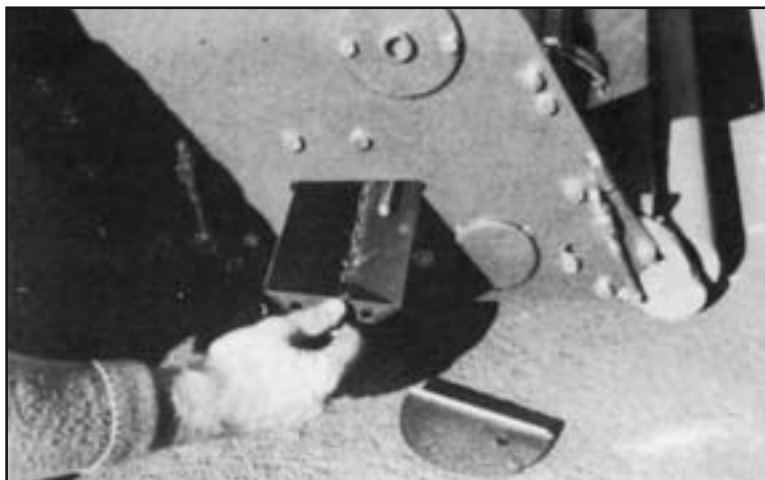

A grass trough is incorporated that can be adjusted closely to the rear drum so that grass and dirt build-up is scraped from the drum and caught in the trough.

TO EMPTY – Remove the cover plate from the trough opening in the side frame.

The cover unclips by pivoting it upward.

Withdraw the trough, as illustrated.

When replacing, the end of the trough could come into contact with its adjusting screw, when half way in. A twisting action will allow the bottom edge of the trough to clear the screw and to push right in.

Replace the cover plate.

NOTE – The trough can be withdrawn more easily if the deflector clamp bolts are loosened and the deflector lowered to allow extra clearance.

ADJUSTMENT – The adjusting screw can only be operated when the trough is removed as it is located under the centre of the trough.

To adjust trough closer to roller, release lock-nut and lower screw slightly – to move it away, raise screw slightly. Replace trough and check clearance from the drum. If satisfactory withdraw trough and tighten lock-nut.

REVERSING CUTTER – A feature of this machine is that the cylinder may be easily removed, reversed end for end and replaced. This provides a new keen cutting edge. If the bottom blade is badly worn, this should be replaced at the same time that the cutting cylinder is reversed or replaced.

To withdraw cutter from machine, first remove cutter chain (7), sprocket (8) and grass deflector (9), refer illus. Page 1. The sprocket is removed by inserting tommy bar in hole in sprocket and giving tommy bar a sharp tap with a hammer. NOTE – The sprocket has a left – hand thread, to unscrew, turn in a clockwise direction.

Remove the grass deflector and deflector supporting bar.

Remove the cutter hanger caps by undoing the holding bolts (10) at each side of the machine. Then the cutter may be taken from the machine by lifting and moving to the chain side of the machine. The opposite side will then clear side frame. Continue with a diagonal lift to complete removal.

Remove the nut from the end of the cutter (it has a left-hand thread).

Reposition this nut at the other end of the cutter.

Turn the cutter end for end and replace in the machine. Then reverse operations used to remove cutter from machine. Replace all bolts and tighten firmly. After reversing cutter it will be necessary to adjust same. Also see detail on chain adjustment.

IMPORTANT: When reversing or replacing the cutter do not remove the cutter bearing hangers. Remove the bearing caps only as instruction. The bearing caps must not be changed over, each cap must be replaced in its original location.

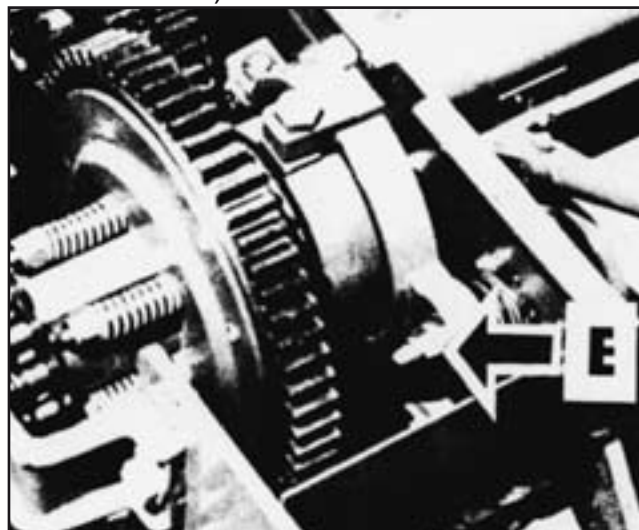

CLUTCH – To be certain that the clutch is fully engaged without possibility of slip, there should be approx. 1 1/2" of free movement (at the clutch operating lever knob) before the resistance of clutch operation is felt. This adjustment is made by means of the self-locking nut "E".

CHAINS – Adjustment – Loosen chain adjustor locking bolt (14) and slide the chain adjustor in the desired direction. A chain should never be adjusted tightly. It is advisable to leave the cutter chain with a little slackness so that slight adjustment of the cutter can be made without having to re-adjust this chain each time.

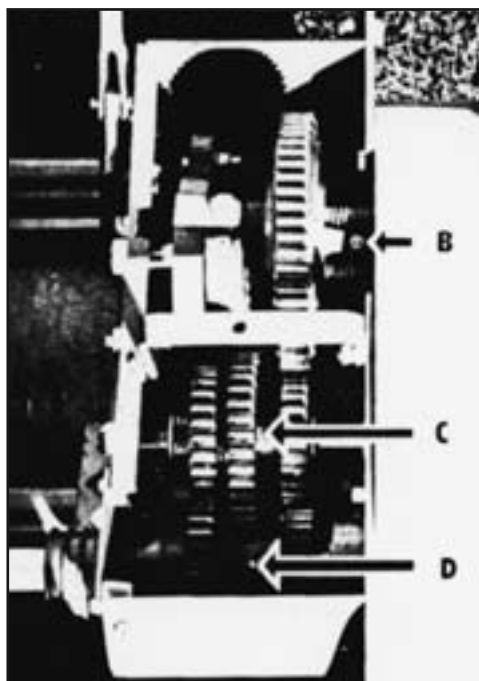

GRASS DEFLECTOR – The grass deflector is adjustable to permit grass to be thrown into the box at the desired angle.

Adjustment – Loosen clamping screws and raise or lower as required.

V-BELT DRIVE – The V-Belt tension is correct when there is about 1/2" up and down movement of the belt midway between the pulleys.

Adjustment – To tighten belt, remove motor cover, loosen four nuts holding down the motor, and force the motor to rear. Then re-tighten nuts.

NOTE: V-Belts are designed to run dry, and under no condition is belt dressing required.

LUBRICATION – Pre-lubricate, sealed ball races are fitted to the cutter, drum shaft, countershaft and front roller. No further lubrication is necessary to these 8 races.

Drums are fitted with special self-lubricating bushes and do not require lubrication.

Driving Chains – grease or medium oil used sparingly.

Gear Box – use medium oil at points B, C and D. Use grease sparingly on gear teeth.

FRONT ROLLER SCRAPER – Loosen clamp bolt each end, adjust scraper to just clear the roller and re-tighten clamps.

CLEANING – This mower is constructed of first-class materials, and will give longer and more efficient service if kept clean. After cutting and before putting machine away, wipe blades down with an oily rag. Occasionally check nuts and bolts for tightness.

WARNING – State Electricity Authority regulations provide that it is always necessary to disconnect power supply before effecting any adjustments to the machine.

ELECTRIC MOTOR

MODEL 300361 1.5 HP 240V SINGLE PHASE 7.3 AMPS.

MODEL 300433 1.5 HP 415V THREE PHASE 2.6 AMPS.

NOTE: Model No: 300361 Queen™ mower is fitted with a manual reset overload switch. The reset button is located on the mains power switch mounted on the right hand side of the handles.

FITTING INSTRUCTIONS 30" TEASING RAKE



1. Remove front roller quadrant bolts and nuts (A and B), and also roller adjusting rod nut (C) at both sides of the mower.



2. This allows front roller assembly, complete with bottom spacer tube to be removed clear of machine.



3. Remove spacer tube from roller assembly by tapping off quadrant from the roller ball race.



4. Replace bottom spacer tube with teasing rake assembly with rake sections facing frontwards.



5. The quadrant bolt "A", must enter the square hole in the rake supporting plate "B", before re-assembly to the mower.



6. Re-adjust front roller to desired height of cut (as described in the mower instruction manual).

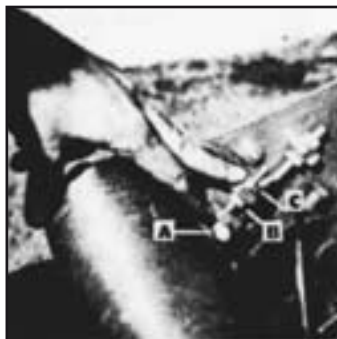

7. Adjust teasing rake depth so that it is just able to tease up the runners. Adjustment is effected by loosening bolt "A". Reverse procedure to lower rake.

7. Adjust teasing rake depth so that it is just able to tease up the runners. Adjustment is effected by loosening bolt "A". Reverse procedure to lower rake.

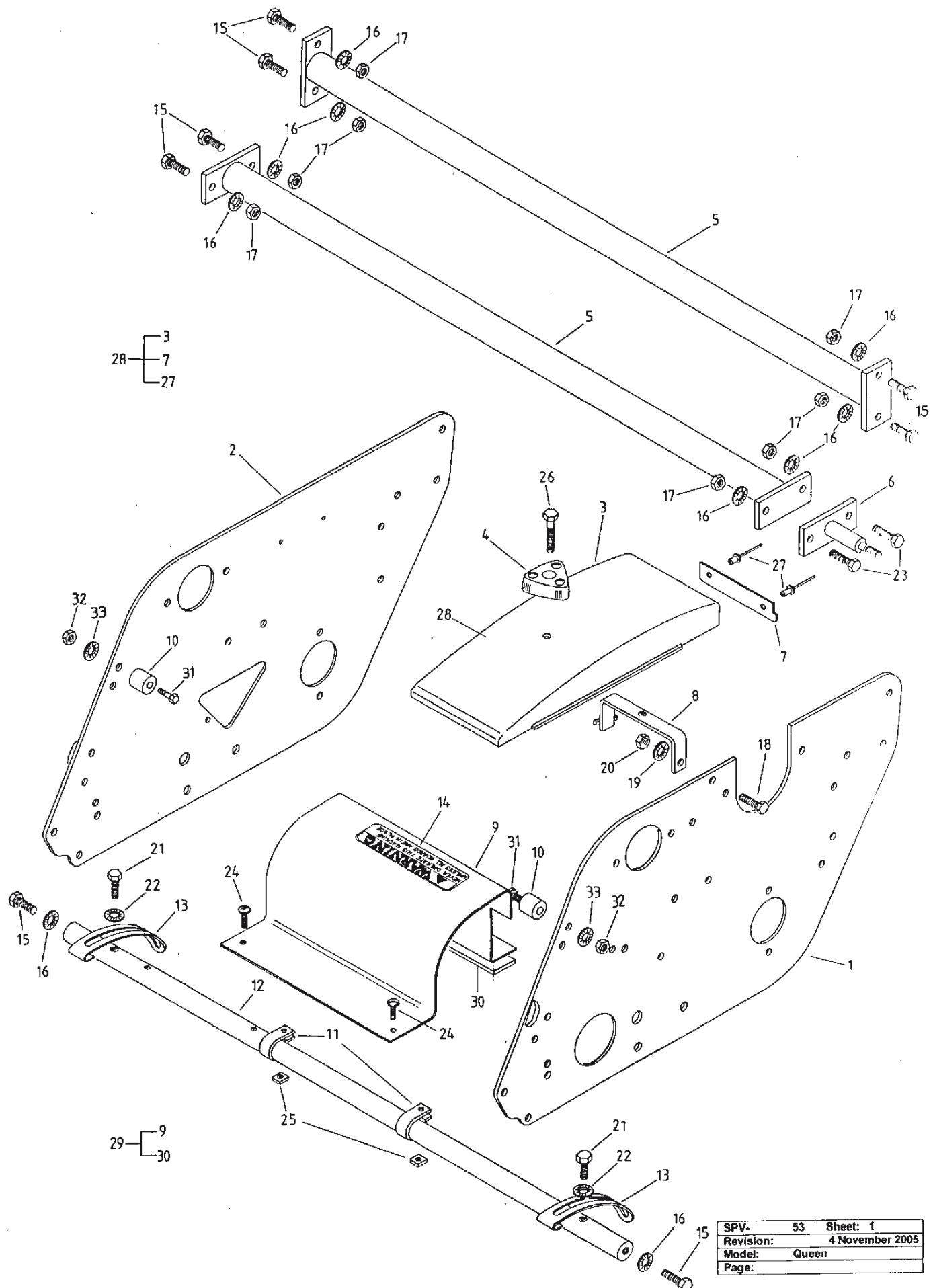

SPV-	53	Sheet: 1
Revision:		4 November 2005
Model:		Queen
Page:		

30" QUEEN™ - SPARE PARTS LIST

ITEM	PART No.	DESCRIPTION
1	305795	Side frame assembly- LH
2	305779	Side frame assembly- RH
3	302148	Clutch housing cover
4	A03285	Knob
5	301428	Main stay tube assembly
6	302033	Cover case mount stud
7	302156	Plate
8	302172	Cover holding bracket assembly
9	305971	Shaft cover
10	305621	Grassbox pivot stud
11	1661775	Clip
12	305630	Top spacer bar
13	305656	Deflector adjuster
14	A12106	Decal- Warning
15	A02110	"Setscrew- 3/8" x 1" unf.HT."
16	A02034	"Washer- 3/8" shakeproof"
17	A02060	"Nut- 3/8" unf.hex."
18	318228	"Setscrew- 1/4" x 3/4" unf.HT."
19	A02044	"Washer- 1/4" shakeproof"
20	232116	"Nut- 1/4" unf.hex."
21	3182102	"Setscrew- 5/16" x 5/8" unf.HT."
22	A02031	"Washer- 5/16" shakeproof"
23	A02166	"Setscrew- 3/8" x 1-1/4" unf.HT."
24	A02163	"Screw- 3/16" x 1/2" mush.head MT."
25	A02050	"Nut- 3/16" square pressed"
26	A02088	"Bolt- 5/16" x 1-1/4" unc.hex"
27	A02075	Rivets- 73 AS 5-5 blind
28	302130	Clutch housing cover assembly
29	305963	Shaft cover assembly
30	305980	Felt strip
31	1204347	"Bolt- 3/8" x 1-3/4" unc."
32	A02008	"Nyloc nut- 3/8" unc."
33	A02033	"Washer- 3/8" x 3/4" x 16g.flat"

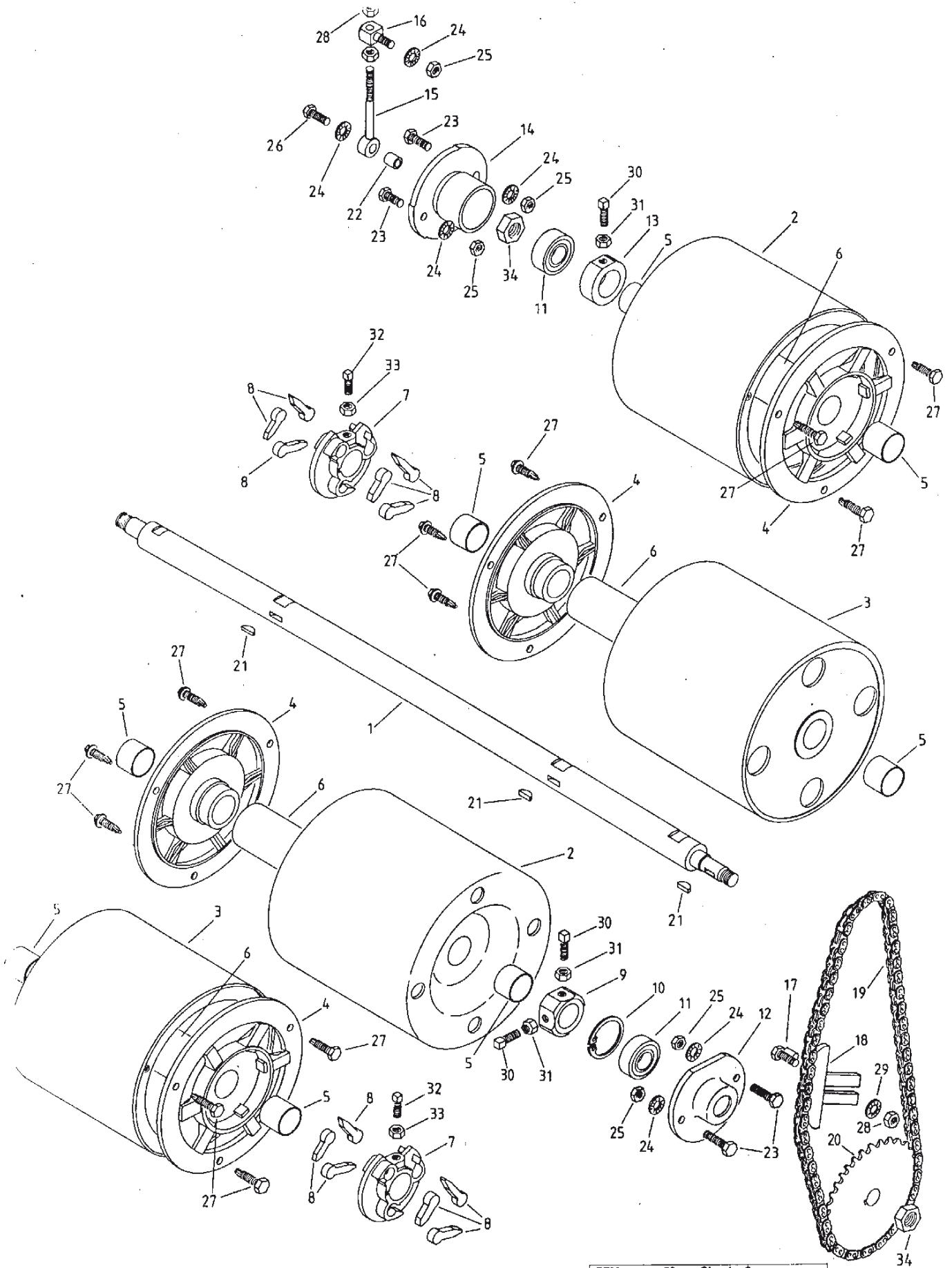

SPV-	63	Sheet: 2
Revision:	4 November 2005	
Model:	Queen	
Page:		

30" QUEEN™ - SPARE PARTS LIST

ITEM	PART No.	DESCRIPTION
1	301217	Drum shaft
2	303992	Drum outer assembly
3	304012	Drum inner assembly
4	301188	Ratchet box assembly
5	3111255	Bush
6	301807	Drum shaft sleeve
7	301196	Pawl retainer
8	333024	Drum pawls
9	301840	Drum shaft collar- LH.
10	1502474	Drum bearing circlip
11	1122422	Drum shaft bearing
12	301815	Drum bearing housing- LH
13	301858	Drum shaft collar
14	304400	Drum bearing- RH.
15	304434	Drum adjustment screw assembly
16	301583	Drum adjustment screw purchase block
17	161461	Chain adjuster bolt assembly
18	161453	Chain adjuster
19	2986543	Drum chain
20	301866	Drum sprocket assembly
21	A05086	Woodruff key
22	304469	Adjustment screw pivot sleeve
23	1212769	Setscrew- 5/16" X 1" unf.HT.
24	A02031	Washer- 5/16" shakeproof
25	2321182	Nut- 5/16" unf.hex.
26	A02083	Setscrew- 5/16" x 3/4" unc.hex.
27	351102	Setscrew- 1/4" x 5/8" unc.hex.
28	A02060	Nut- 3/8" unf.hex.
29	A02034	Washer- 3/8" shakeproof
30	3162322	Setscrew- 3/8" x 3/4" square head
31	A02007	Nut- 3/8" unc.hex.
32	A02080	Grubscrew- 5/16" x 1/2" unc.socket
33	A02004	Nut- 5/16" unc.hex
34	171660	Locknut- 5/8" unf.hex.

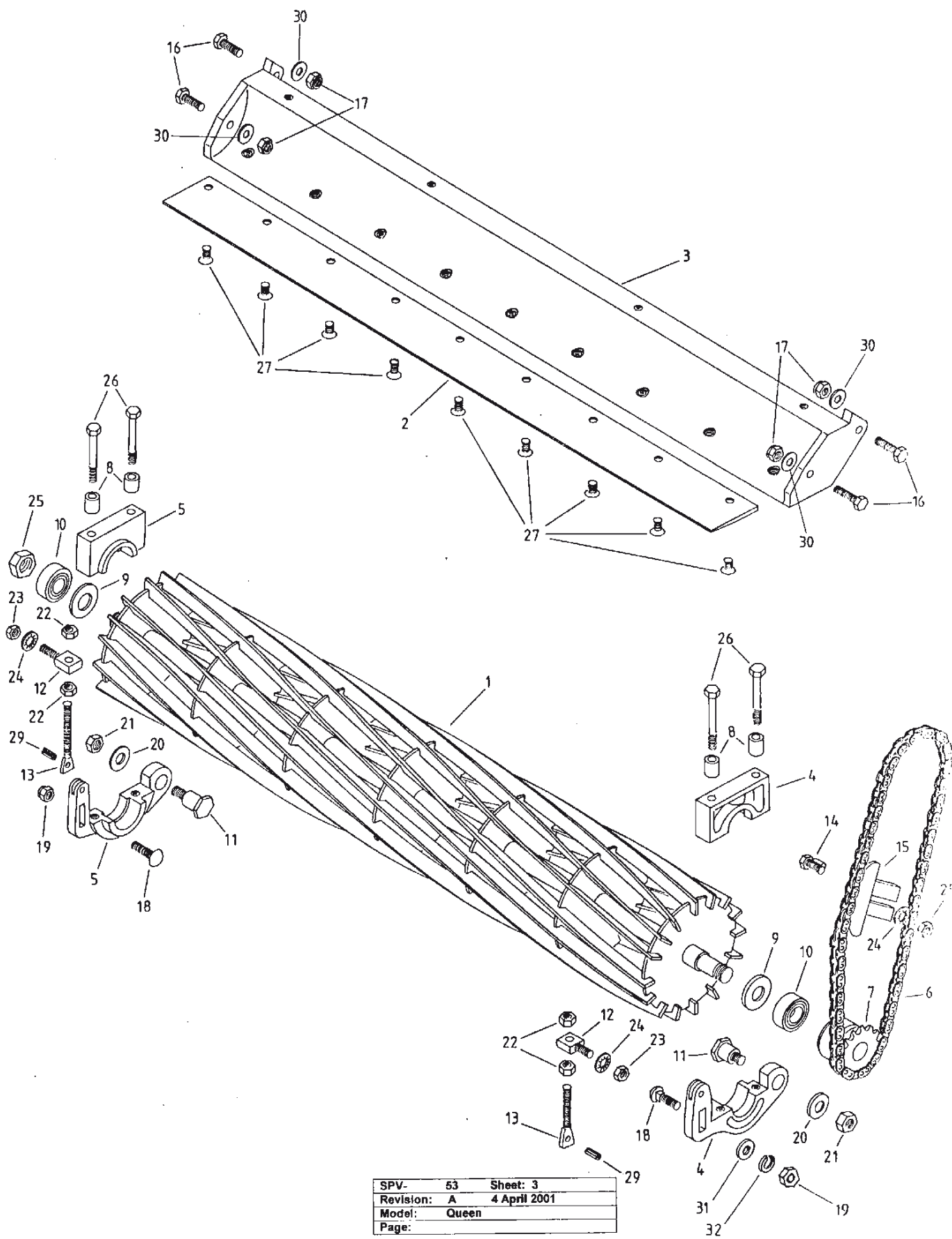

SPV-	53	Sheet: 3
Revision:	A	4 April 2001
Model:	Queen	
Page:		

30" QUEEN™ - SPARE PARTS LIST

ITEM	PART No.	DESCRIPTION
1	306122	Blade cutter assembly- 10 blades
1	10168	Blade cutter assembly- 16 blades
2	393000	Bottom blade- low cut
3	301735	Sole plate
4	301647	Cutter bearing housing assembly- LH
5	301698	Cutter bearing housing assembly- RH
6	2986519	Chain- countershaft to cutter
7	165340	Cutter sprocket
8	301680	Hanger cap bolt spacer
9	163432	Bearing cover washer
10	A07744	Cutter bearing
11	163440	Bearing housing pivot bolt
12	301727	Cutter adj.screw purchase block
13	301719	Cutter adjustment screw
14	161461	Chain adjuster bolt assembly
15	161453	Chain adjuster
16	1213325	Bolt- 7/16" x 1-1/4" unf.HT.
17	2641238	Nyloc nut- 7/16" unf.
18	A04069	Bolt- 3/8" x 1-1/4" unc.cuphead
19	A02007	Nut- 3/8" unc.Hex
20	A02063	Washer- 1/2" x 1" x 16g.flat
21	A02046	Nut- 1/2" unf.hex.
22	2321182	Nut- 5/16" unf.hex.
23	A02060	Nut- 3/8" unf.hex.
24	A02034	Washer- 3/8" shakeproof
25	2671289	Locknut- 3/4" unf.left hand
26	1185887	Bolt- 5/16" x 3" unc.
27	2071924	Screw- 5/16" x 1/2" csk.M/T.
28	A02060	Nut- 3/8" unf.hex.
29	2211047	Roll pin- 3/16" x 1/2"
30	A02035	Washer- 7/16" x 7/8" x 16g.flat
31	A04033	Washer- 3/8" x 3/4" x16g.flat
32	A04112	Washer- 3/8" spring

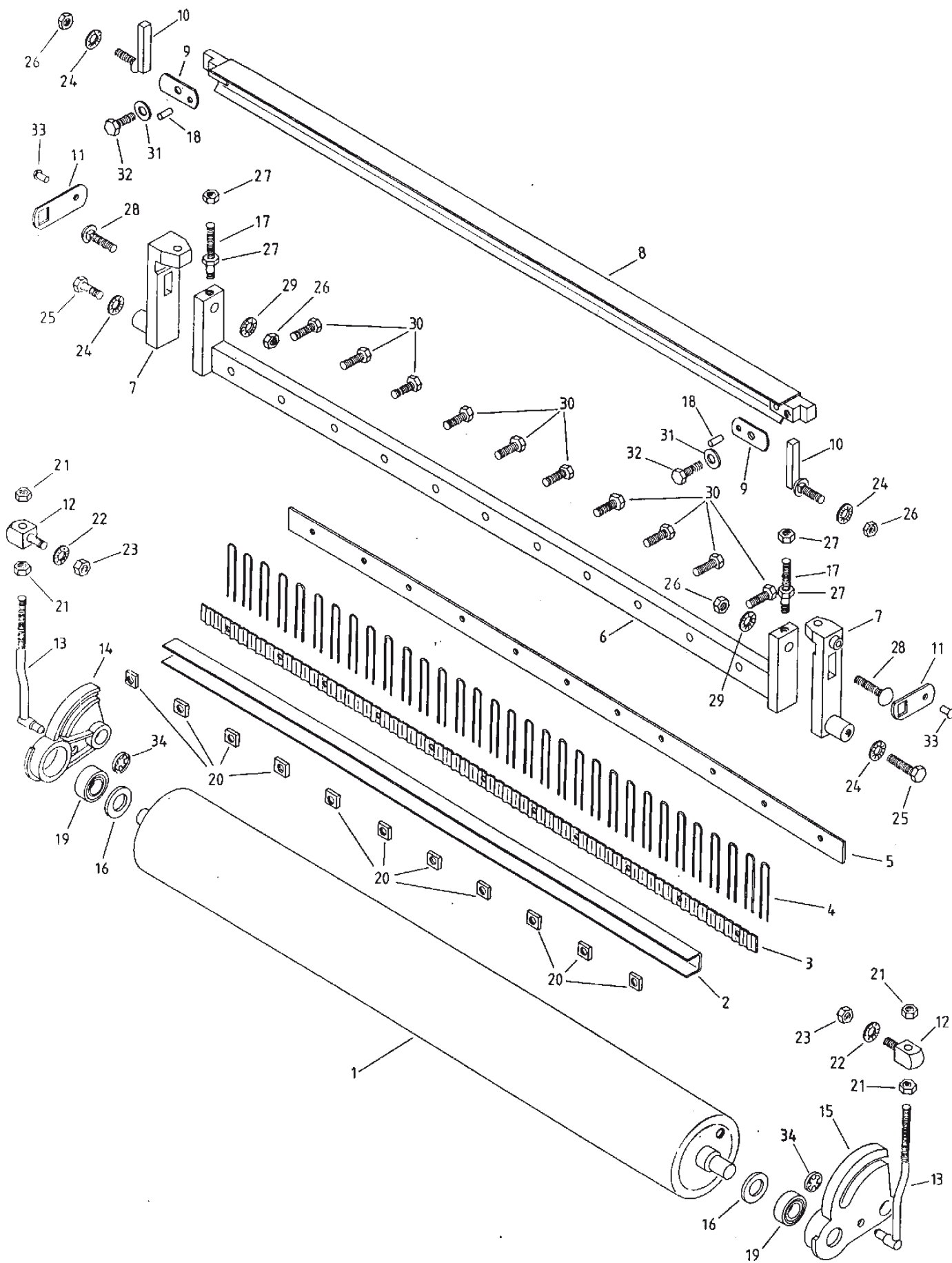

SPV-	53	Sheet: 4
Revision:	A	17 February 2000
Model:	Queen	
Page:		

30" QUEEN™ - SPARE PARTS LIST

ITEM	PART No.	DESCRIPTION
1	301516	Front roller assembly
2	304506	Clamping channel
3	304514	Clamping tyne guide
4	166246	Rake tynes- 32 per set
5	304522	Clamping rubber
6	304485	Rake bar assembly
7	303423	Rake bar mounting bracket
8	303440	Front roller scrape bar assembly
9	303490	Scraper clamp plate
10	303503	Scraper bolt assembly
11	303431	Mounting bracket support
12	301583	Adjusting rod purchase block
13	301559	Front roller adjusting rod assembly
14	301049	Front roller bracket- RH
15	301030	Front roller bracket- LH
16	301057	Bearing seal washer
17	303407	Height adjusting stud
18	2211047	Roll pin- 3/16" x 1/2"
19	1122327	Front roller bearing
20	2491162	Nut- 1/4" sq.pressed w/series AF.445
21	A02060	Nut- 3/8" unf.hex.
22	A02031	Washer- 5/16" shakeproof
23	2321182	Nut- 5/16" unf.hex
24	A02034	Washer- 3/8" shakeproof
25	A04144K	Setscrew- 3/8" x 1" unf.HT. Grade 8
26	A02007	Nut- 3/8" unc.hex.
27	232116	Nut- 1/4" unf.hex
28	A07769	Bolt- 3/8" x 1-1/2" unc.cuphead
29	A02034	Washer- 3/8" shakeproof
30	A02169	Setscrew- 1/4" x 1" unc.
31	A02030	Washer- 5/16" x 5/8" x 18g.flat
32	3182102	Setscrew- 5/16" x 1" unf.HT.
33	1841057	Pin- 1/2" x No:10
34	2501108	Starlock- 7301/0008 1/4" Advel

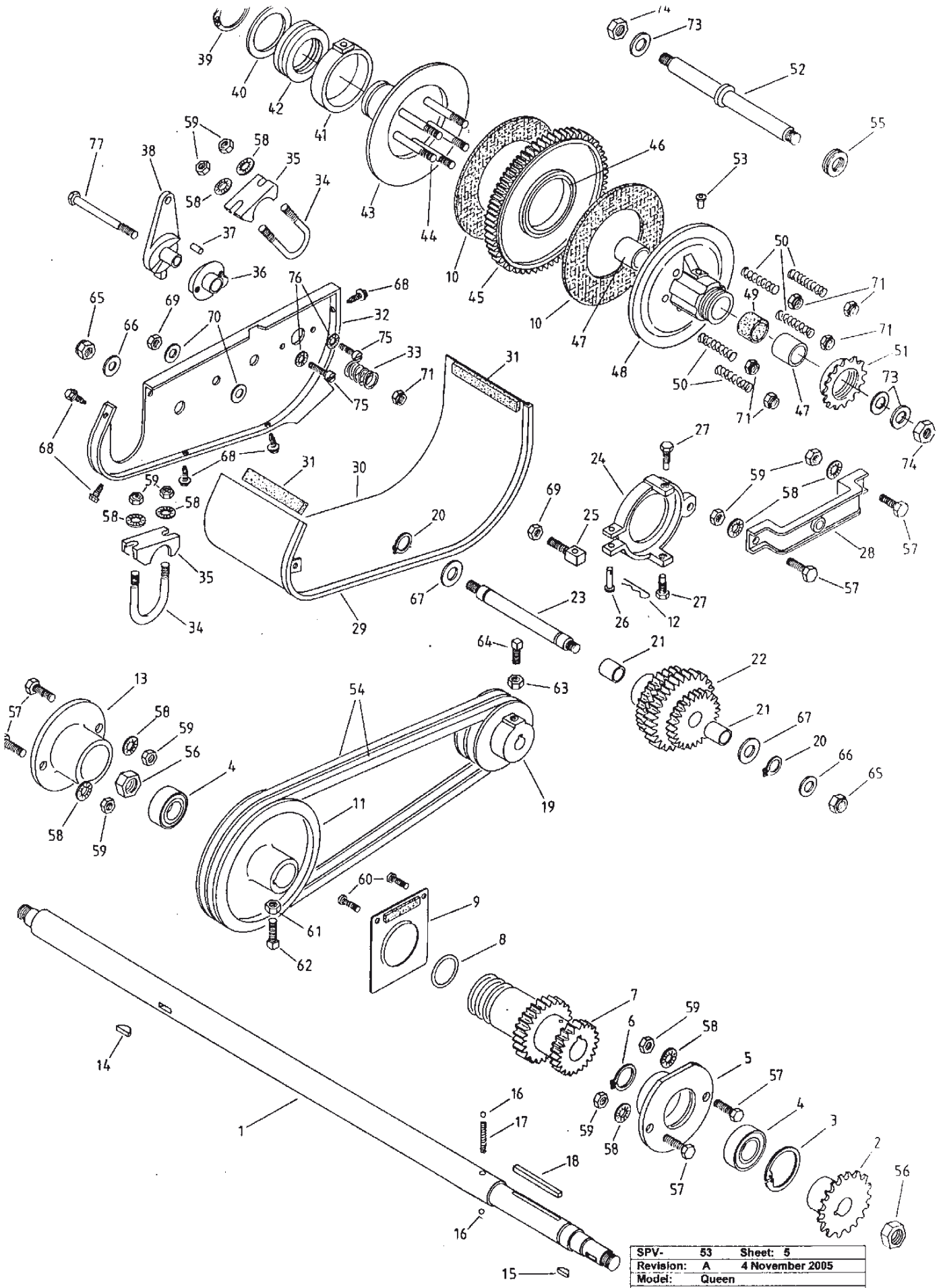

SPV-	53	Sheet: 5
Revision:	A	4 November 2005
Model:	Queen	
Page:		

30" QUEEN™ - SPARE PARTS LIST

ITEM	PART No.	DESCRIPTION	ITEM	PART No.	DESCRIPTION
1	302869	Countershaft	41	306106	Clutch release trunnion
2	301962	Countershaft sprocket	42	3534040	Clutch release thrust race
3	1502474	Circlip	43	306093	Clutch plate
4	1122422	Countershaft bearing	44	302236	Clutch spring stud
5	301815	Countershaft bearing housing- LH.	45	306325	Drum clutch gear
6	1501052	Circlip	46	657598	Bush- drum clutch gear
7	302383	Countershaft gear	47	3111271	Clutch plate bush
8	2721210	Countershaft gear seal	48	301268	Clutch plate - sprocket side
9	302201	Clutch housing side cover	49	302210	Felt oil strip
10	301276	Clutch plate lining	50	302244	Clutch spring
11	301954	Countershaft pulley	51	302228	Drum clutch sprocket- 14 tooth
12	A01080	Spring pin	52	302279	Drum clutch shaft
13	301823	Countershaft bearing housing- RH.	53	1111164	Ball oiler
14	3802747	Woodruff key- pulley	54	3601289	Vee belt
15	A05086	Woodruff key- countershaft	55	3531018	Clutch shaft thrust race
16	3421166	Countershaft locating ball- 1/4"	56	171660	Locknut- 5/8" unf.hex.
17	302391	Spring	57	1212769	Bolt- 5/16" x 1" unf.HT.
18	302404	Countershaft gear key	58	A02031	Washer- 5/16" shakeproof
19	305525	Motor pulley	59	2321182	Nut- 5/16" unf.hex.
20	A02224	Circlip	60	A02049	Screw- 3/16" x 3/4" m/head slotted
21	3111030	Bush	61	A02004	Nut- 5/16" unc.hex.
22	302412	Inter cluster gear	62	A02082	Setscrew- 5/16" x 3/4" unc.chcp.
23	302420	Intermediate gear shaft	63	A02001	Nut- 1/4" unc.hex.
24	302308	Clutch release yoke	64	A04005	Setscrew- 1/4" x 1" unc.chcp.
25	302316	Clutch yoke pillar	65	2641238	Nyloc nut- 7/16" unf.hex.
26	A02076	Yoke pin	66	A02035	Washer- 7/16" x 7/8" x 16g.flat
27	302324	Trunnion pivot screw	67	A02054	Washer- 5/8" x 1-1/4" x 14g.flat
28	302121	Clutch shaft support bracket	68	A04052	Self tapping screw- 10 x 5/8" pan.p/h
29	A20205	Rubber seal	69	A02060	Nut- 3/8" unf.hex
30	302092	Clutch housing body assembly	70	A02033	Washer- 3/8" x 3/4" x 16g.flat
31	A20204	Rubber seal	71	A02045	Nyloc nut- 1/4" unf.hex.
32	302068	Clutch housing side	72		
33	302375	Clutch ramp spring	73	A02063	Washer- 1/2" x 1" x 16g.flat
34	302084	Seat block clamp	74	A02046	Nut- 1/2" unf.hex.
35	302076	Housing side seat block	75	2061886	Metal thread- 3/16" x 1/2" c/head
36	302340	Clutch ramp- fixed	76	A02234	Washer- 3/16" shakeproof
37	302359	Clutch ramp- stop	77	1215863	Bolt- 1/4" x 3" unf.HT.
38	305509	Clutch ramp- adjustable			
39	1501122	Circlip			
40	306114	Release thrust washer			

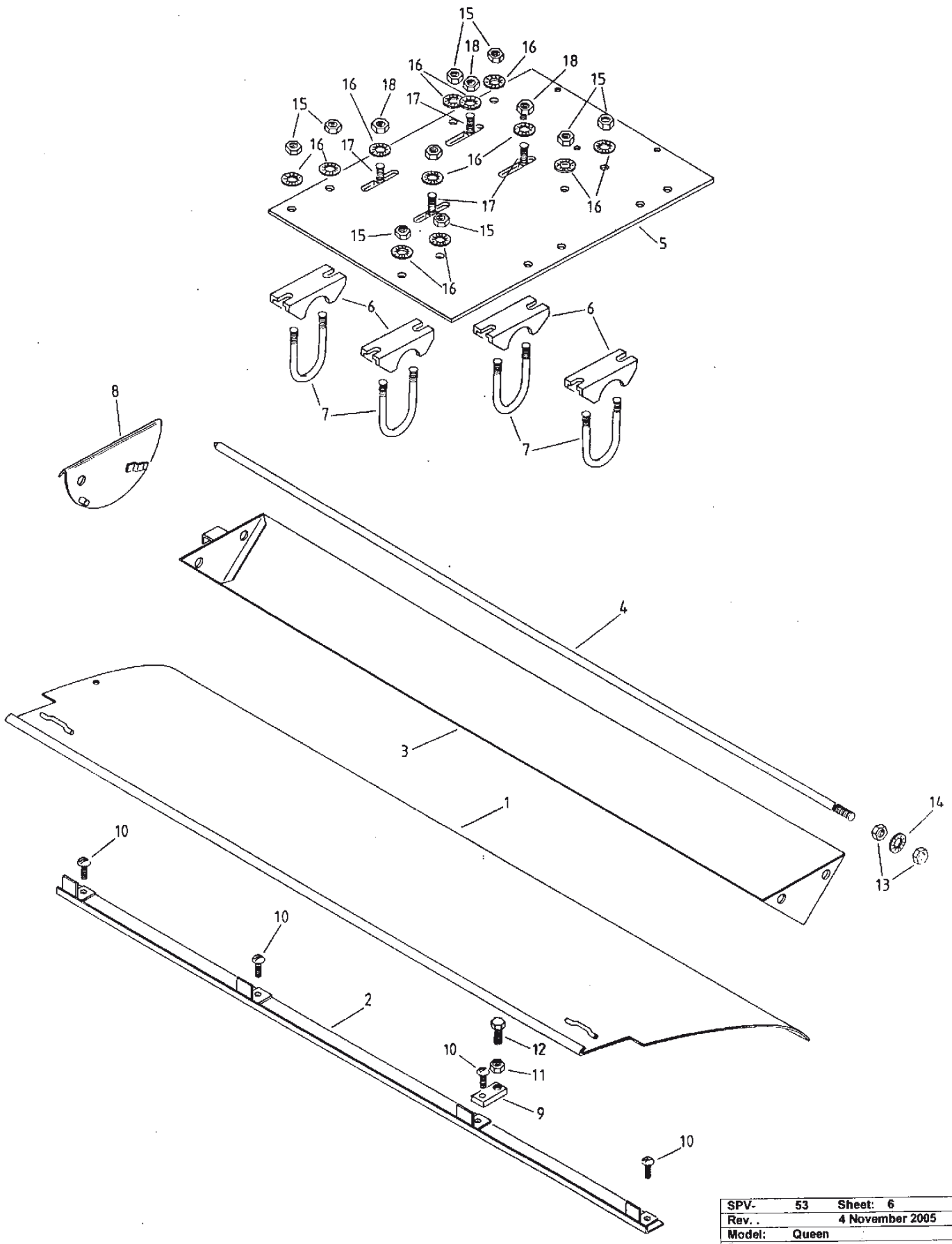

SPV-	53	Sheet: 6
Rev. .		4 November 2005
Model:	Queen	
Page:		

30" QUEEN™ - SPARE PARTS LIST

ITEM	PART No.	DESCRIPTION
1	305648	Deflector assembly
2	301065	Deflector strip assembly
3	305664	Scraper trough assembly
4	305701	Trough pivot bar
5	305920	Motor table
6	302076	Table seat block
7	302084	Seat block clamp
8	305728	Trough cover plate assembly
9	305752	Trough support
10	2051907	Metal thread- 1/4" x 1/2" round head
11	A02001	Nut- 1/4" unc.hex.
12	A02146	Setscrew- 1/4" x 3/4" unc.hex.
13	A02060	Nut- 3/8" unf.hex.
14	A02034	Washer- 3/8" shakeproof
15	2321182	Nut- 5/16" unf.hex.
16	A02031	Washer- 5/16" shakeproof
17	A02085	Bolt- 5/16" x 1" unc.cuphead
18	A02004	Nut- 5/16" unc.hex.

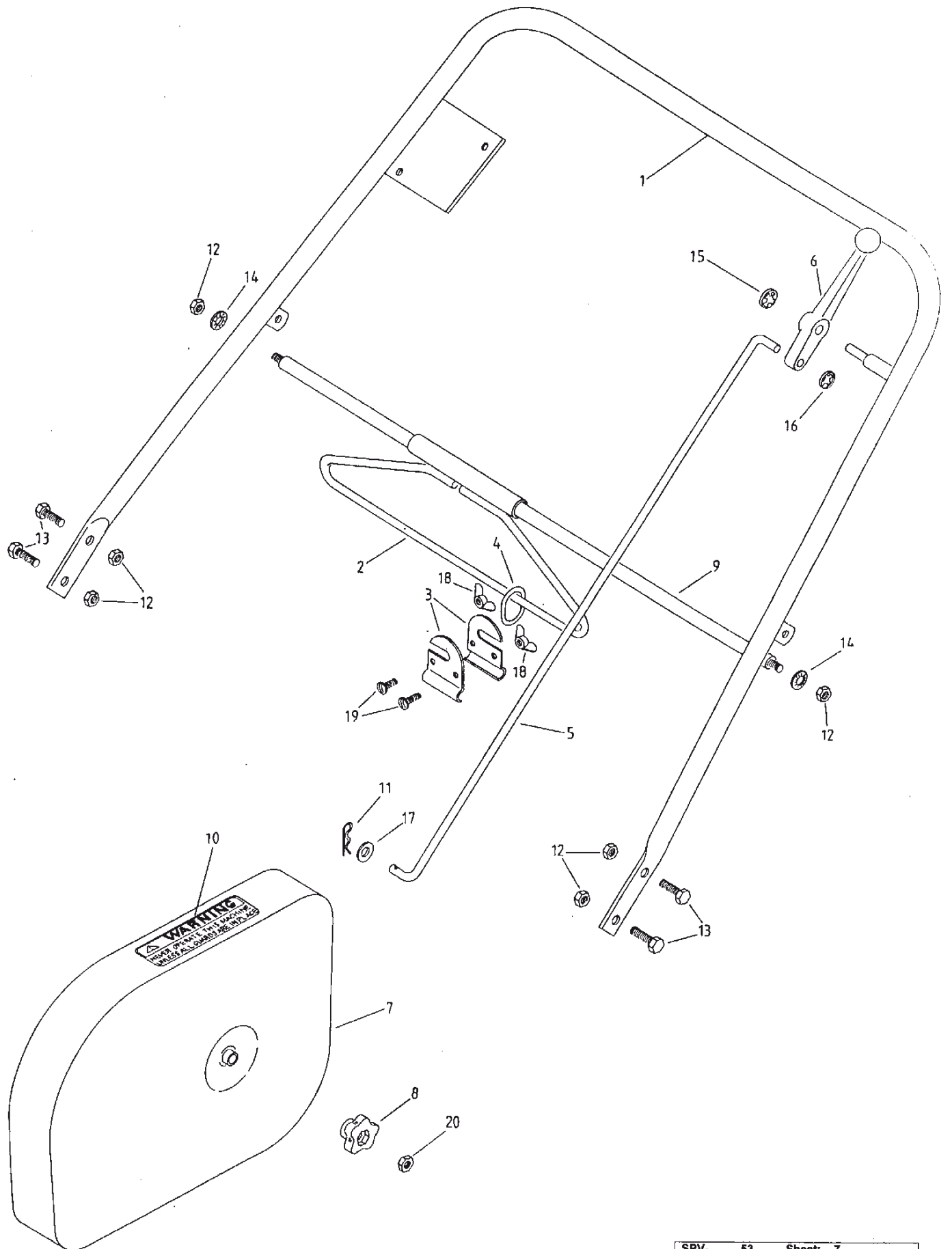

SPV-	53	Sheet: 7
Rev.		4 November 2005
Model:	Queen	
Page:		

30" QUEEN™ - SPARE PARTS LIST

ITEM	PART No.	DESCRIPTION
1	305390	Handle assembly
2	305445	Cord carrier assembly
3	173024	Cord grip
4	163029	Cord grip ring
5	305496	Clutch control rod
6	305470	Clutch lever
7	301970	Chain cover case
8	A03285	Chain cover knob
9	305437	Cord carrier bar
10	A12106	Decal- warning
11	A01080	Spring pin
12	A02060	Nut- 3/8" unf.hex.
13	A02110	Setscrew- 3/8" x 1" unf.HT.
14	A02034	Washer- 3/8" shakeproof
15	2501116	Starlock- 3/8" 7301/0012 Avdel
16	2501054	Starlock- 8mm Avdel
17	A02030	Washer- 5/16" x 5/8" 18g.flat
18	2531120	Wing nut- 3/16" unc.
19	A02049	Metal thread- 3/16" x 3/4" mush.head
20	A02223	Nyloc nut- 5/16" unc.

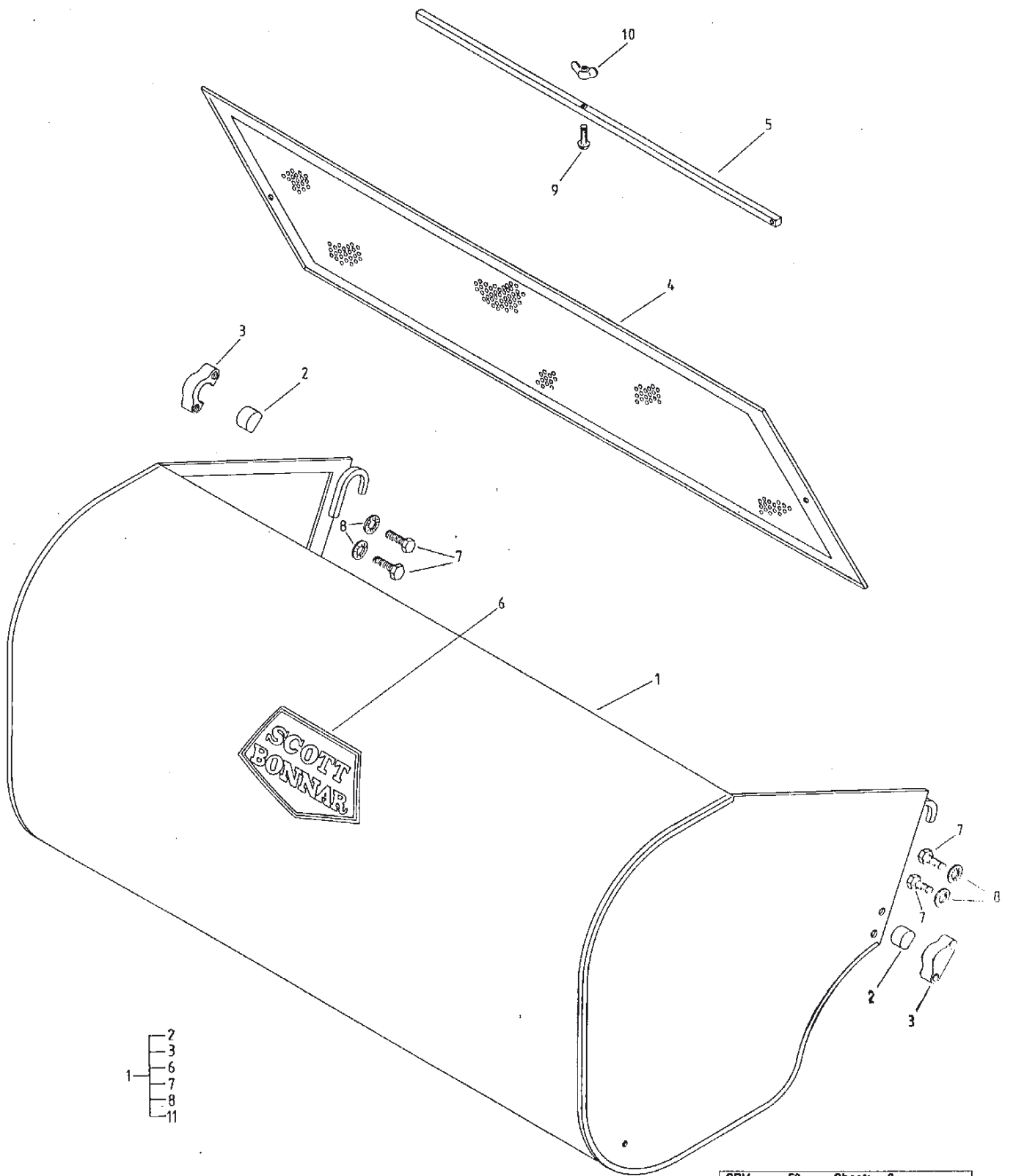

SPV-	53	Sheet: 8
Rev.		4 November 2005
Model:	Queen	
Page:		

30" QUEEN™ - SPARE PARTS LIST

ITEM	PART No.	DESCRIPTION
1	302640	Grassbox assembly
2	164275	Rubber pad
3	164267	Pad mount
4	300847	Grassbox screen assembly
5	303028	Height cut setting bar
6	509819	Decal- Scott Bonnar
7	3172749	Setscrew- 1/4" x 1" unc.HT.
8	A02044	Washer- 1/4" shakeproof
9	A02169	Setscrew- 1/4" x 1" unc.hex.
10	2531160	Wingnut- 1/4" unc.
11	302658	Grass box

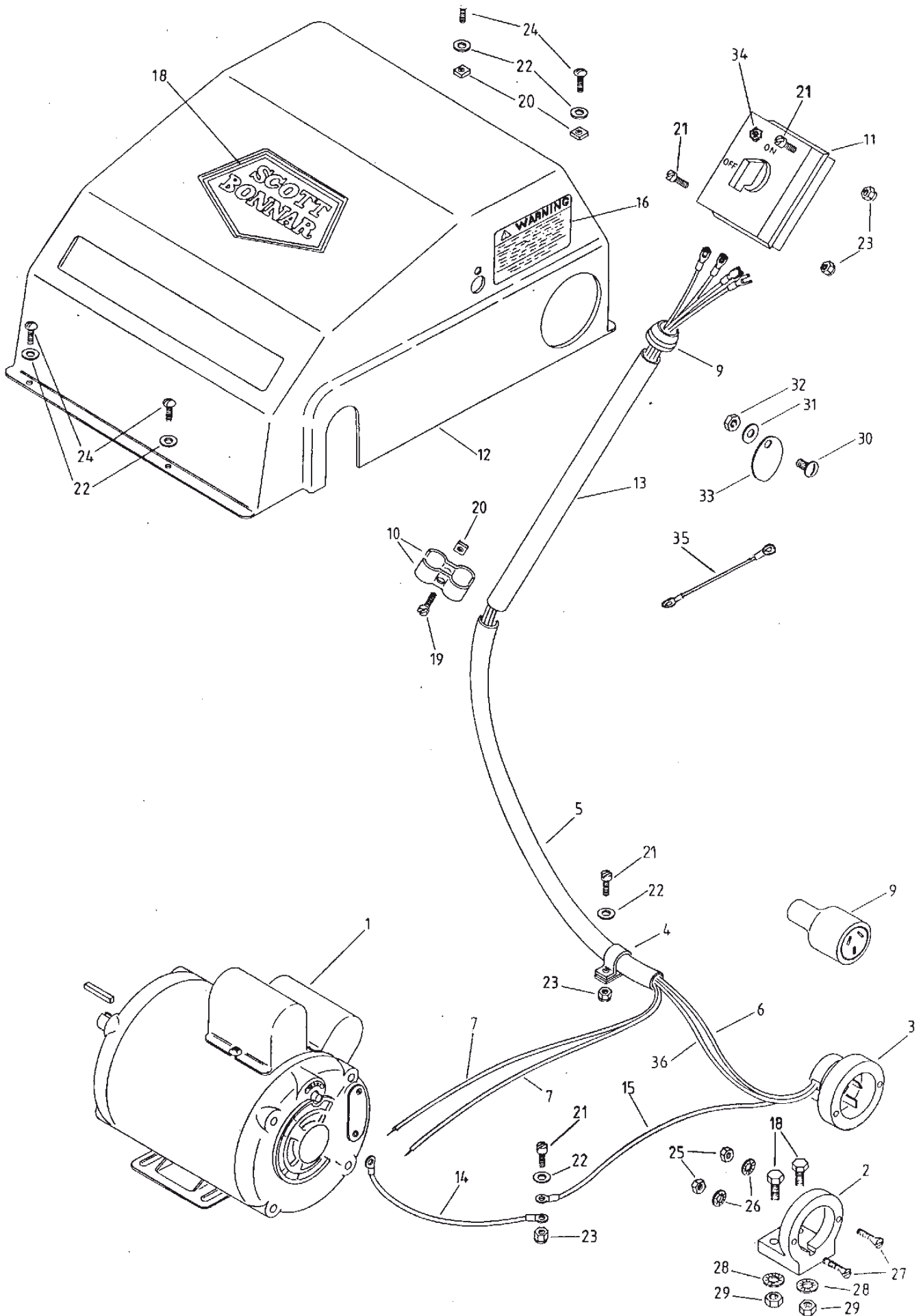

SPV-	53	Sheet: 9
Rev.	B	16 May 2001
Model:	Queen	
Page:		

30" QUEEN™ - SPARE PARTS LIST

ITEM	PART No.	DESCRIPTION
1	A80084	Electric motor
2	305584	Plug mounting bracket
3	1661150	Plug- male
4	1661775	Cable clamp
5	1551265	Plastic conduit- flexible
6	A20207	Electrical wire- red
7	A20206	Electrical wire- black
8	306368	Cable gland
9	1661235	Plug- female
10	303124	Conduit clip
11	A20211	Switch
12	306341	Motor cover assembly
13	305373	Conduit
14	A20209	Earth wire
15	A20208	Earth wire
16	301649	Decal- warning
17	509819	Decal- Scott Bonnar
18	318228	Setscrew- 1/4" x 3/4" unf.HT.
19	2062724	Screw- 3/16" x 1" cheese head M/T.
20	A02050	Nut- 3/16" square pressed
21	2061886	Screw- 3/16" x 1/2" cheese head M/T.
22	A02216	Washer- 3/16" x 1/2" x 20g.flat
23	A02193	Nyloc nut- 3/16" unc.thin
24	A02163	Screw- 3/16" x 1/2" mush.head M/T.
25	A02023	Nut- 5/32" unc.hex.
26	A02039	Washer- 5/32" shakeproof
27	2072711	Screw- 5/32" x 1" bsw.csk.
28	A02044	Washer- 1/4" shakeproof
29	232116	Nut- 1/4" unf.hex.
30	A02017	Screw- 1/4" x 1/2" unc.Slotted Mush.head.
31	A02209	Washer- 1/4" x 5/8" x 18g.flat
32	A02235	Nyloc nut- 1/4" unc.
33	655533	Reset cover
34	A20044	Reset switch
35	A20210	Trip wire
36	A20213	Electrical wire- red reset switch

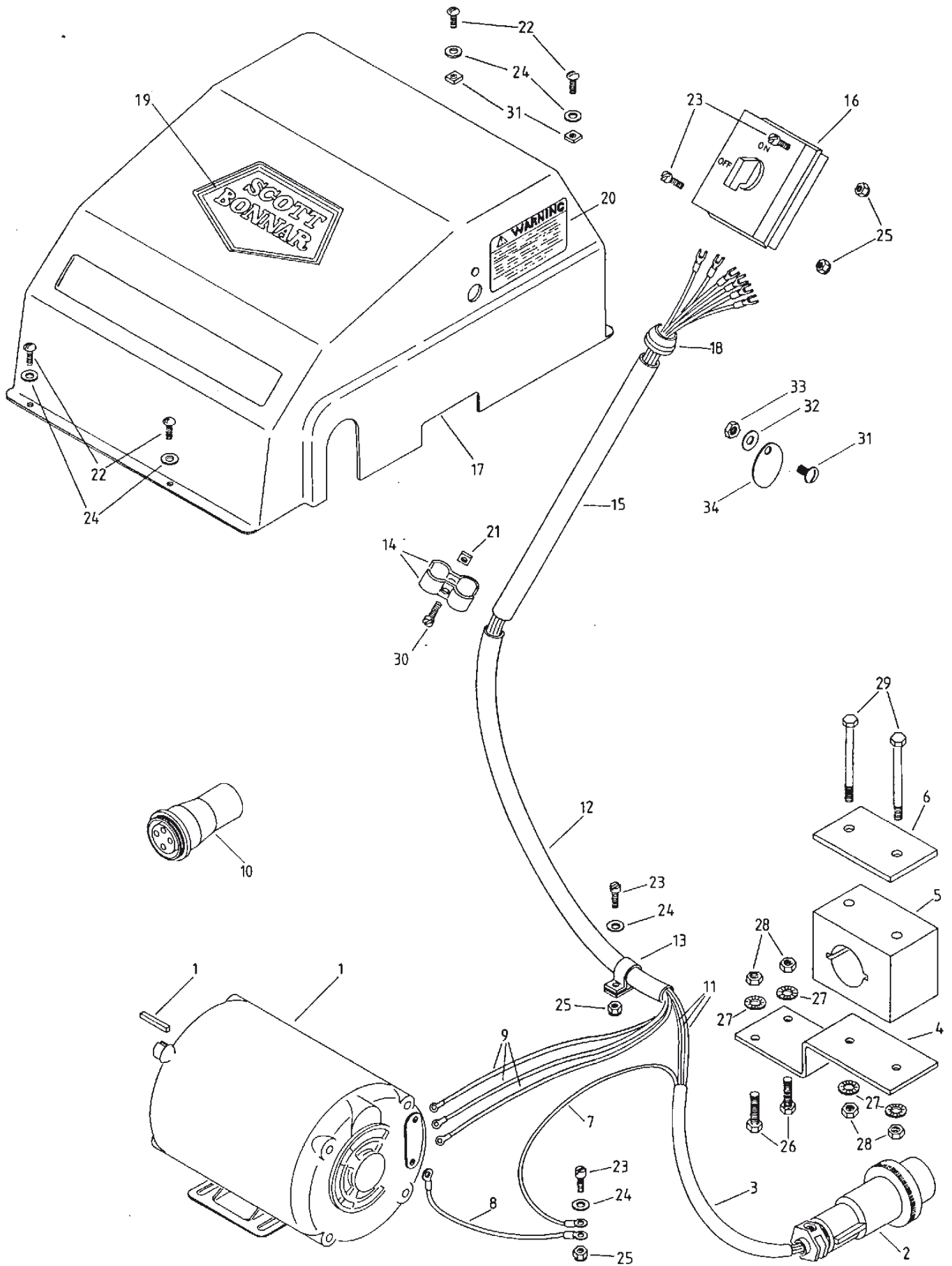

SPV-	53	Sheet:	10
Rev.	A	16 May	2001
Model:	Queen		
Page:			

30" QUEEN™ - SPARE PARTS LIST

ITEM	PART No.	DESCRIPTION
1	1674306	Electric motor
2	1661253	Plug- WIP 410B male
3	306405	Conduit
4	655517	Plug mounting bracket
5	655525	Plug insulating mount
6	655509	Mount cap
7	A20202	Earth wire
8	A20203	Earth wire
9	A20201	Electrical wire- red
10	1661245	Socket- WIP 0410 female
11	A20200	Electrical wire- black
12	1551265	Plastic conduit- flexible
13	1661775	Cable clamp
14	303124	Conduit clip
15	305373	Conduit
16	A20212	Switch
17	306333	Motor cover
18	306368	Cable gland
19	509819	Decal- Scott Bonnar
20	301648	Decal- warning
21	A02050	Nut- 3/16" square pressed
22	A02163	Screw- 3/16" x 1/2" mush.head M/T.
23	2061886	Screw- 3/16" x 1/2" cheese head M/T.
24	A02216	Washer- 3/16" x 1/2" x 20g.flat
25	A02193	Nyloc nut- 3/16" unc.thin
26	A02110	Setscrew- 3/8" x 1" unf.HT.
27	A02033	Washer- 3/8" x 3/4" x 16g.flat
28	A02220	Nyloc nut- 3/8" unf.hex.
29	A02278	Bolt- 3/8" x 3-3/4" unf.HT.
30	2062724	Screw- 3/16" x 1" cheese head M/T.
31	A02107	Screw- 1/4" x 1/2" unc.Slotted Mush.head
32	A02209	Washer- 1/4" x 5/8" x 18g.flat
33	A02235	Nyloc nut- 1/4" unc.
34	655533	Reset cover

Warranty Conditions

AUSTRALIA & NEW ZEALAND ONLY

Rover Mowers Limited warrant that this machine is free from defects in material and workmanship. This warranty is limited to making good or replacing any part which appears upon inspection by the manufacturer or his agent to be defective in material or workmanship.

The engine used to power this machine is warranted by the manufacturer whose warranty statement has been included with the machine. As the warranty for the engine may differ from the warranty for the other components, you are advised to read the engine manufacturer's warranty carefully

For other items this warranty shall apply for a period of 12 months from the date of purchase except for products used commercially where the warranty is limited to 90 days.

This warranty does not obligate the manufacturer, his agents or dealers to bear the transport costs incurred in the repair or replacement of any defective part.

This warranty excludes fair wear and tear, or any damage caused by misuse or abuse. Parts such as blades, blade bolts, v-belts and spark plugs, which can be subjected to use beyond their normal intended working capacity are also excluded.

This warranty is void if parts other than genuine have been used or if repairs or alterations have been made without the manufacturer's written authority.

The above warranty does not exclude any condition or warranty implied by the Trade Practices Act 1974 or any other relevant legislation which implies any condition which cannot be excluded.

REMEMBER:
PROOF OF PURCHASE IS THE RESPONSIBILITY OF THE OWNER AND IS NECESSARY PRIOR TO WARRANTY WORK BEING UNDERTAKEN. REPAIRS MUST BE CARRIED OUT BY AN AUTHORISED ROVER DEALER /SERVICE AGENT AND GENUINE SPARE PARTS MUST BE USED OR YOUR WARRANTY WILL BE VOID.

Online Warranty Registration - www.rovermovers.com.au

For your record:

Dealer's Name:

Dealer's Address:

Dealer's Phone No:

Product Model No:

Product Serial No:.....

Date of Purchase:.....



Quality Endorsed Company

ISO 9001 Lic 10168 Standards Australia

Rover Mowers Limited reserves the right to make changes of and add improvements upon its product at any time without notice or obligation. The Company also reserves the right to discontinue manufacture of any product at its discretion at any time.

ROVER

Mowers Limited

A.B.N. 11 000 257 303

Rover Mowers Australia
PO Box 1235
Eagle Farm, Qld 4009
Australia.



RECYCLED PAPER

This Rover Owners Manual has been printed on 100% Australian recycled paper as a sign of Rover Mowers' commitment to Greening Australia and New Zealand.

Rover Mowers New Zealand
East Tamaki,
Auckland,
New Zealand.



GWAIL GROUP

PRINTED IN AUSTRALIA

S1943676
Rev. C.

© Copyright 11/2005

Free Manuals Download Website

<http://myh66.com>

<http://usermanuals.us>

<http://www.somanuals.com>

<http://www.4manuals.cc>

<http://www.manual-lib.com>

<http://www.404manual.com>

<http://www.luxmanual.com>

<http://aubethermostatmanual.com>

Golf course search by state

<http://golfingnear.com>

Email search by domain

<http://emailbydomain.com>

Auto manuals search

<http://auto.somanuals.com>

TV manuals search

<http://tv.somanuals.com>