

# Installation, Operation and Maintenance Manual



## Oil Fired Warm Air Furnace

### HO-B Series Up-flow or Horizontal Model

THE INSTALLATION OF THIS FURNACE SHALL BE IN ACCORDANCE WITH THE REGULATION OF AUTHORITIES HAVING JURISDICTION AND NFPA STANDARD 31 (U.S.A.) OR CSA STANDARD B139 (CAN.).

**FOR YOUR SAFETY**  
Do not store or use gasoline or other flammable vapors or liquids in the vicinity of this or any other appliance.

Oneida Royal Division  
Utica, New York

Please read this manual completely before beginning installation. These instructions must be kept with the furnace for future reference.



29733 R2 06/01/2003

How to read an Oneida Royal Model Number:

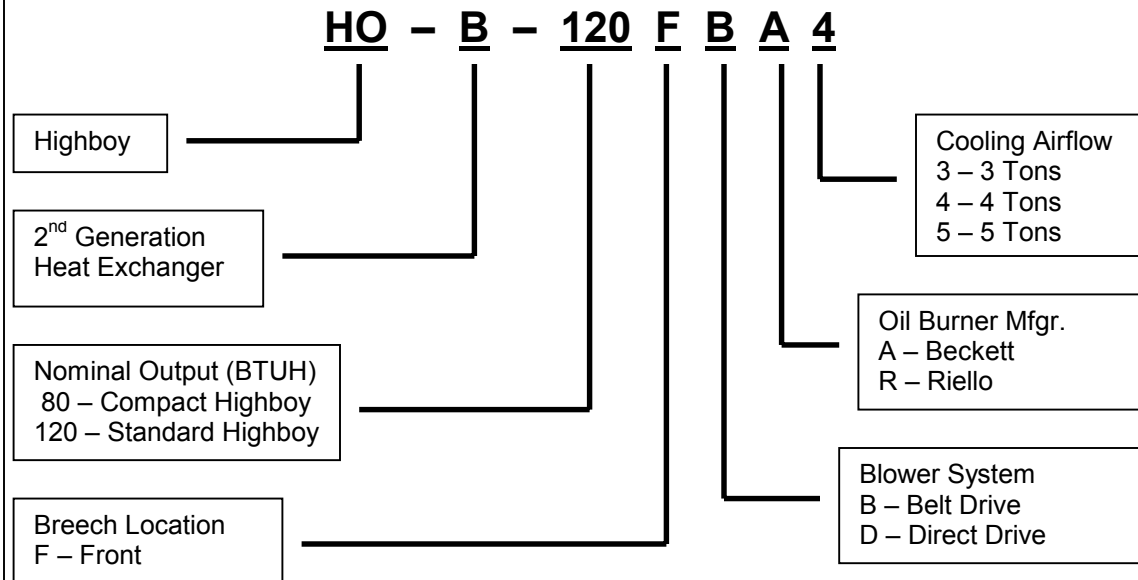

In the above example, the furnace is an Oneida Royal Highboy with the 2<sup>nd</sup> generation heat exchanger, standard size, front breeched, belt drive, Beckett Oil Burner, 4 tons of cooling.

In this Installation, Operation & Maintenance Manual, the models will be abbreviated as 80F for compact models, and 120F for standard models.

## Table of Contents

1. Introduction.....	4
2. Heat Loss.....	4
3. Location of Unit .....	4
4. Air Conditioning Applications .....	6
5. Combustion Air.....	6
6. Chimney Venting .....	7
7. Barometric Damper Control.....	8
8. Furnace Controls .....	9
9. Electrical Connections .....	9
10. Humidifier.....	10
11. Oil Tank.....	10
12. Piping Installation.....	10
13. Oil Filter .....	11
14. Oil Burner Nozzles.....	11
15. Combustion Chamber .....	11
16. Burner Electrodes.....	12
17. Oil Burner Set Up.....	12
18. Circulating Air Blower .....	14
19. Maintenance and Service.....	15
20. Furnace Installation Set Up .....	16
21. Operating Instructions .....	17
Table A-1 Beckett AF Oil Burner Set-Up.....	18
Table A-2 Riello 40F Oil Burner Set-Up .....	18
Table A-3 Direct Drive Blower Set-Up.....	19
Table A-4 Direct Drive Blower Characteristics .....	19
Table A-5 Belt Drive Blower Set-Up .....	20
Table A-6 Belt Drive Blower Characteristics.....	20
General Dimensions .....	21
Wiring Diagram: Oil Furnace With ST9103 EFT & R7184 Control.....	22
Wiring Diagram: Oil Furnace With ST9103 EFT & Riello Oil Burner.....	23
Wiring Notes: .....	24
R7184 Detailed Sequence of Operation.....	25
Table C-1: ST9103 Detailed Sequence of Operation .....	29
R7184 LED Diagnostic Light.....	31
Table C-2: Cad Cell Resistance .....	31
Table C-3: R7184 Troubleshooting .....	32
Table C-4: System and General Troubleshooting .....	36

**IMPORTANT:**  
**SAVE THESE INSTRUCTIONS FOR FUTURE REFERENCE**

**1. INTRODUCTION**

Please read these instructions completely and carefully before installing and operating the furnace.

The furnace must be installed and set up by a qualified contractor

**MODEL 80F**

Model 80F is an oil-fired upflow forced air furnace, with an output capacity range of 58,100 BTU/Hr. to 78,900 BTU/Hr. The 80F furnace equipped with a direct drive blower may be installed in both horizontal positions.

**MODEL 120F**

Model 120F is an oil-fired upflow forced air furnace, with an output capacity range of 87,700 BTU/Hr. to 113,400 BTU/Hr. The 120F furnace equipped with a direct drive blower may be installed in both horizontal positions.

**NOTE:** Furnace models equipped with belt drive blowers are not suitable for horizontal applications.

Both 80F & 120F Model furnaces are listed with the **Canadian Standards Association, (CSA)**, complies with both Canadian and American (U.S.) standards for use with No. 1 (Stove) and No. 2 (Furnace) Oil. Please refer to the tables in the appendix for performance and dimensional data.

**⚠ WARNING**  
**DO NOT USE GASOLINE, CRANK CASE OIL, OR ANY OIL CONTAINING GASOLINE.**

In the United States of America, the installation of the furnace and related equipment shall be installed in accordance with the regulations of **NFPA No. 31, Installation of Oil Burning Equipment**, as well as in accordance with local codes.

In Canada, the installation of the furnace and related equipment shall be installed in accordance with the regulations of **CAN/CSA - B139, Installation Code For Oil Burning Equipment**, as well as in accordance with local codes.

When installation or application questions arise, regulations prescribed in the National Codes and Local

Regulations take precedence over the general instructions provided with this installation manual. When in doubt, please consult your local authorities.

All models are shipped assembled and pre-wired. The furnace should be carefully inspected for damage when being unpacked.

**2. HEAT LOSS**

To determine the correct furnace and firing rate for an application, it is necessary to calculate the maximum hourly heat loss of the building based on local design conditions. In new construction, the heat loss should be calculated on a room-by-room basis to enable proper sizing of the trunk and branch ducts. In retrofit applications, a building shell (overall) heat loss calculation may be used.

In the United States, **Manual J**, titled, "**Load Calculation**" published by the **Air Conditioning Contractors of America**, describes a suitable procedure for calculating the maximum hourly heat loss.

In Canada, the maximum hourly heat loss may be calculated in accordance with the procedures described in the manuals of the **Heating, Refrigeration and Air Conditioning Institute of Canada (HRAI)**, or by other method prescribed by authorities having jurisdiction that are suitable for local conditions.

**3. LOCATION OF UNIT**

The furnace should be located such that the flue connection to the chimney is short, direct and consists of as few elbows as possible. When possible, the unit should be centralized with respect to the supply and return air duct work. A central location minimizes the trunk duct sizing. All models may be installed on combustible floors.

Minimum installation clearances are listed in Table 1.

**Table 1: Clearance to Combustibles**

HO-B – All Models		
Location	Up-flow	Horizontal
Top	2 in.	2 in.
Bottom	0 in.	1 in.
S/A Plenum	1 in.	1 in.
Rear	1 in.	1 in.
Sides	1 in.	1 in.
Front	9 in. <sup>1</sup>	9 in. <sup>1</sup>
Flue Pipe	9 in.	9 in.
Enclosure	Closet	Alcove
<sup>1</sup> 24" clearance is required for servicing.		

**TABLE 2.: GENERAL SPECIFICATIONS**

BECKETT AFG BURNER						
MODEL	INPUT U.S. GPH	OUTPUT BTU/Hr.	NOZZLE (Delavan)	BURNER MODEL	BURNER HEAD	PUMP PRESSURE
80F	0.50	58,100	0.50 / 70° W	AF76BO	F0	100 PSIG
	0.65	68,000	0.65 / 70° W	AF76BN	F3	
	0.70	78,900	0.70 / 70° W	AF76BN	F3	
120F	0.75	87,700	0.75 / 70° W	AF76BZHS	F4	100 PSIG
	0.85	98,800	0.85 / 70° W			
	1.00	113,400	1.00 / 70° W			

NOTES: OVER-FIRE DRAFT FOR ALL MODELS IS -0.02 IN. W.C.  
 STATIC PLATE DIAMETER: 3-3/8 inch for AF76BO and 2-3/4 inch for AF76XN.

RIELLO 40F3 BURNER						
MODEL	INPUT U.S. GPH	OUTPUT BTU/Hr.	NOZZLE (Delavan)	PUMP PRESSURE	TURBULATOR SETTING	AIR BAND SETTING
80F	0.50	58,000	0.40 / 60°W	160 PSIG	1.5	2.25
	0.60	73,000	0.50 / 60°W	150 PSIG	1.5	2.5
	0.70	79,000	0.60 / 60°W	145 PSIG	2.0	3.0
120F	0.75	87,000	0.60 / 60°W	150 PSIG	2.0	3.5
	0.85	100,000	0.70 / 60°W	150 PSIG	2.5	4.0
	0.95	112,000	0.75 / 60°W	160 PSIG	3.0	6.0

NOTE: OVER-FIRE DRAFT FOR ALL MODELS IS -0.02 IN. W.C.

**NOTE:** The recommended installation clearances do not take into consideration the clearances necessary to replace the air filter or perform other routine maintenance.

**UP-FLOW INSTALLATION**

Both furnaces models have been assembled for installation in the up-flow position. Maintain all clearances to combustibles as outlined in Table 1. *Suggestion;* as a measure to prevent fuel oil from accumulating in locations other than the fire pot, as could be the case in the event of nozzle drip, install the furnace with an approximate 2 degree slope from the oil burner casing towards the fire pot. Use shims made of noncombustible material.



Heat Exchanger Support Screw

In the upflow position, the heat exchanger support screw shown in picture may be removed. This may be preferable if the furnace rear panel will be inaccessible after installation. The screw must be removed if the heat exchanger must be removed from the cabinet. Do not remove this screw if installing furnace in a horizontal position.

**HORIZONTAL INSTALLATION**

The furnaces are assembled and shipped ready for installation in the up-flow position. The direct drive equipped furnace may be installed in either of the horizontal positions; warm air discharging left or warm air-discharging right by following these steps:

1. Rotate the furnace 90° to the desired position.
2. Remove the three nut and washer sets fastening the oil burner assembly to the furnace (Beckett Burner) or loosen the burner mount Allen screw (Riello burner). Rotate the oil burner assembly to be in the normal upright position.
3. Re-align the oil burner assembly to the combustion chamber (fire-pot), then secure into place with the three nut and washer sets (Beckett burner) or by re-tightening the mounting Allen screw (Riello burner).

## NON-SUSPENDED INSTALLATION

Maintain clearances to combustibles as outlined in Table 1. Installation on a combustible floor requires a clearance of 1 inch. This can be done by using a noncombustible material such as one-inch thick channel iron or similar material. The furnace must be supported in such a way as to not allow twisting or sagging of the cabinet. Suggestion; as a measure to prevent fuel oil from accumulating in locations other than the fire pot, as could be the case in the event of nozzle drip, install the furnace with an approximate 2 degree slope from the oil burner casing towards the fire pot. Use shims made of noncombustible material.

## SUSPENDED INSTALLATION

Refer to Figure 1. Maintain clearances to combustibles as outlined in Table 1. The furnace may be suspended by field fabricating a cradle of angle iron and threaded rod. Secure the furnace with 2 inch minimum slotted angle or equivalent, as shown in Figure 1. The furnace must be supported in such a way as to not allow twisting or sagging of the cabinet. Position the supports so as to not interfere with accessing the burner and blower compartments. Suggestion; as a measure to prevent fuel oil from accumulating in locations other than the fire pot, as could be the case in the event of nozzle drip, install the furnace with an approximate 2 degree slope from the oil burner casing towards the fire pot.

## 4. AIR CONDITIONING APPLICATIONS

If the furnace is used in conjunction with air conditioning, the furnace shall be installed in parallel with or upstream from the evaporator coil to avoid condensation in the heat exchanger. In a parallel installation, the dampers or air controlling means must prevent chilled air from entering the furnace. If the dampers are manually operated, there must be a means of control to prevent the operation of either system unless the dampers are in the full heat or full cool position. The air heated by the furnace shall not pass through a refrigeration unit unless the unit is

specifically approved for such service.

The blower speed must be checked and adjusted to compensate for the pressure drop caused by the evaporator coil. Refer to Appendix B for recommended wiring and electrical connections of the air conditioning controls.

## 5. COMBUSTION AIR

When a furnace is installed in the full basement of a typical frame or brick house, infiltration is normally adequate to provide air for combustion and draft operation. If the furnace is installed in a closet or utility room, two (2) ventilation openings must be provided connecting to a well ventilated space (full basement, living room or other room opening thereto, but not a bedroom or bathroom). One opening shall be located 6" from the top and bottom of the enclosure at the front of the furnace. For furnaces located in buildings of unusually tight construction, such as those with high quality weather stripping, caulking, windows and doors, or storm sashed windows, or where basement windows are well sealed, a permanent opening communicating with a well ventilated attic or with the outdoors shall be provided, using a duct if necessary. Size all of the openings and associated ductwork by the standards provided in the latest Oil Installation Code editions; NFPA 31 in the United States, CAN/CSA B139 in Canada. Take all fuel burning appliances in the area into consideration when calculating combustion and ventilation air requirements.

The Model CAS-2B-90E Furnace Boot manufactured by Field Controls, Inc. may be used with the furnace to obtain combustion air directly from outdoors. Use of this device does not alter the need for ventilation air; however, it does provide a good direct source of combustion air and is connected directly to the oil burner.

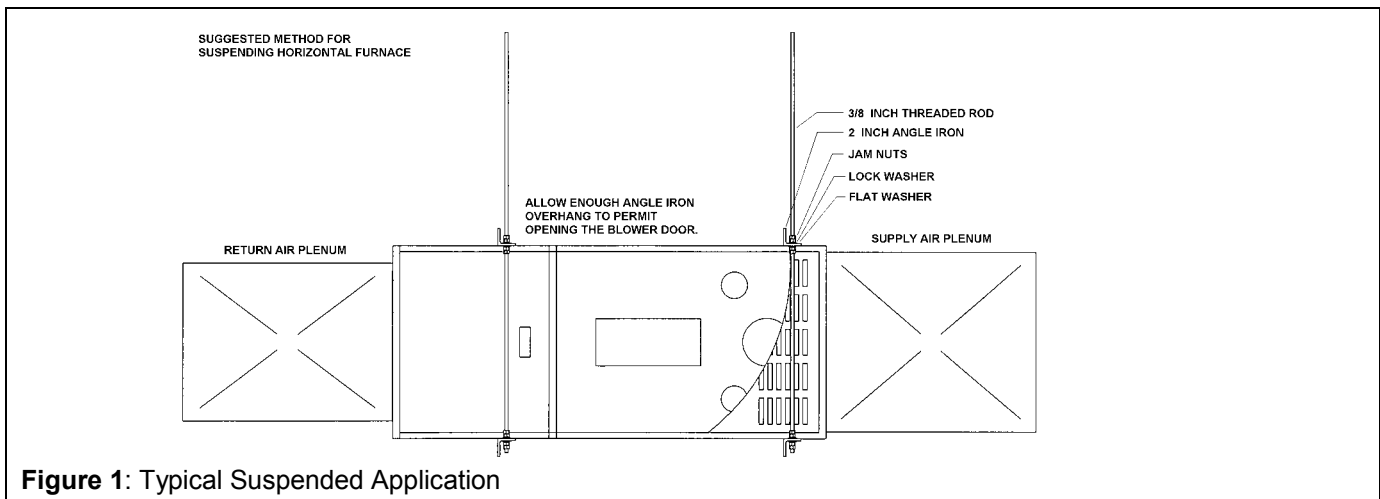

**Figure 2: Common Chimney Problems**

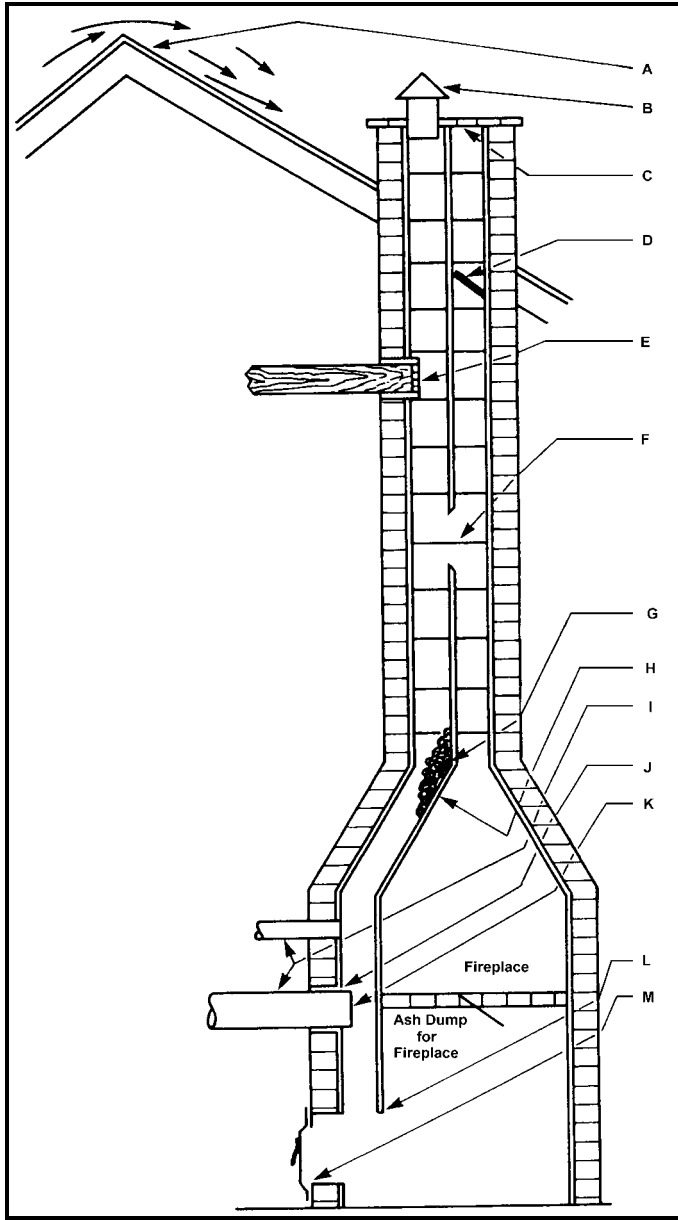

**6. CHIMNEY VENTING**

The chimney must be sized correctly and be in good repair. If the chimney is oversized, there is a high risk of the flue gases condensing resulting in damage to the chimney and other venting parts. This problem may be corrected by the use of an appropriately sized chimney liner.

If the chimney serves the furnace only, the vent should be sized at 4 inch minimum, 5 inch maximum. The table below is based on dedicated venting. If the furnace is to be co-vented with other appliances, refer to **NFPA 31, *Standard for the Installation of Oil Burning Equipment*** and **NFPA 211, *Standard for Chimneys, Fireplaces, Vents, and Solid Fuel-Burning Appliances*** or **CAN/CSA B139,**

*Installation Code For Oil Burning Equipment* for correct sizing information

**Table 3: Common Chimney Problems**

Refer to Figure 2			
Key	Trouble	Diagnostic	Remedy
A	Top of chimney lower than surrounding objects	Observation	Extend chimney above all surrounding objects within 30 feet.
B	Chimney Cap or ventilator.	Observation	Remove
C	Coping restricts opening.	Observation	Make opening as large as inside of chimney.
D	Obstruction in chimney	Can be found by light and mirror reflecting conditions in chimney.	Use weight to break and dislodge.
E	Joist protruding into chimney.	Lowering a light on an extension cord.	Must be handled by competent masonry contractor.
F	Break in chimney lining.	Smoke test - build smudge fire blocking off other opening, watching for smoke to escape.	Must be handled by competent masonry contractor.
G	Collection of soot at narrow space in flue opening.	Lower light on extension cord.	Clean out with weighted brush or bag of loose gravel on end of line.
H	Offset	Lower light on extension cord.	Change to straight or to long offset.
I	Two or more openings to the same chimney.	Found by inspection from basement.	The least important opening must be closed, using some other chimney flue.
J	Loose-seated pipe in flue opening.	Smoke test.	Leaks should be eliminated by cementing all pipe openings.

Table 2: Common Chimney Problems - continued

Key	Trouble	Diagnostic	Remedy
K	Smoke pipe extends into chimney.	Measurement of pipe from within or observation of pipe by means of a lowered light.	Length of pipe must be reduced to allow end of pipe to be flush with inside of tile.
L	Failure to extend the length of flue partition to the floor.	By inspection or smoke test.	Extend partition to floor level.
M	Loose-fitted clean-out door.	Smoke test.	Close all leaks with cement.

**NOTE: This furnace is approved for use with L-Vent.**

**NOTE: Maximum temperature for L-Vent is 575°F (300°C).**

Table 4: Min. Chimney Base Temperatures (°F)

Model	Chimney Height (ft.)			
	11	20	28	36
Chimneys with Thermal Resistance less than R6				
80F (060)	300	400	535	725
80F (070)	275	340	430	535
80F (080)	270	330	405	505
120F (090)	260	320	380	475
120F (100)	250	300	355	430
120F (120)	225	300	365	430
Model	Chimney Height (ft.)			
	11	20	28	36
Chimneys with Thermal Resistance greater than R6				
80F (060)	185	200	220	250
80F (070)	175	185	205	220
80F (080)	175	185	195	215
120F (090)	175	185	195	210
120F (100)	165	185	195	205
120F (120)	165	185	195	205

**IMPORTANT:** The chimney must be capable of providing sufficient draft at all times for the safe removal of the products of combustion.

The chimney should be tested under "winter" conditions; doors and windows closed, all other fossil fuel burning

appliances on, clothes dryer on, bathroom fans on, etc. If the chimney cannot overcome the competition for air, it will be necessary to access the reason for it, and take corrective action. If the chimney is found to be sized correctly and in good repair, it will probably be necessary to re-evaluate the availability of combustion and ventilation air, and take corrective action.

The flue pipe should be as short as possible with horizontal pipes sloping upward toward the chimney at a rate of one quarter inch to the foot. The flue pipe should not be smaller in cross sectional area than the flue collar on the furnace. The flue pipe should connect to the chimney such that the flue pipe extends into, and terminates flush with the inside surface of the chimney liner. Seal the joint between the pipe and the lining. The chimney outlet should be at least two feet above the highest point of a peaked roof. All unused chimney openings should be closed. Chimneys must conform to local, provincial or state codes, or in the absence of local regulations, to the requirements of the National Building Code.

See Figure 2 and Table 3 for common chimney problems and their remedies.



The flue pipe must not be routed through concealed space, because it must be visually checked for signs of deterioration during the annual inspection and servicing. The flue pipe must not pass through any floor or ceiling, but may pass through a wall where suitable fire protection provisions have been installed. Refer to the latest edition of CAN/CSA B139 for rules governing the installation of oil burning equipment. In the United States, refer to the latest edition of NFPA 31 for regulations governing the installation of oil burning equipment.

## 7. BAROMETRIC DAMPER CONTROL

This device is used in conjunction with conventional chimney venting. This control (or draft regulator) automatically maintains a constant negative pressure in the furnace to obtain maximum efficiency. It ensures that proper pressures are not exceeded. If the chimney does not develop sufficient draft, the draft control cannot function properly. The draft regulator, must be installed within the same room or enclosure as the furnace, and should not interfere with the combustion air supplied to the burner. The control should be located a minimum of 3 flue pipe diameters from the furnace breeching and



installed in accordance to the instructions supplied with the regulator.

## 8. FURNACE CONTROLS

The furnace is controlled by either of two systems, depending on the oil primary control and electronic fan timer combination. System 1, used with Beckett burners, includes the blower mounted Honeywell ST9103 ELECTRONIC FAN TIMER (EFT) combined with the R7184 OIL PRIMARY CONTROL. System 2, used with Riello burners, includes the blower mounted Honeywell ST9103 ELECTRONIC FAN TIMER (EFT) combined with a transformer / burner relay mounted internally on the 40F3 burner housing to operate the oil burner.



Figure 3: R7184 Oil Primary

The furnace functions are controlled by either System 1 or System 2, and bi-metallic snap disc limit switches. These groupings also provide control for add-on air conditioning. The ST9103 EFT is located in a control box mounted to the blower support rails.

The circulating fan is controlled by the ST9103 EFT. The heat delay-on time is fixed, at 30 seconds. This provides a delay between the start of the burner and the start of the circulating fan to reduce the amount of ambient unheated air flowing through the ductwork. The end of the circulating fan cycle is also delayed to remove residual heat from the furnace. There are four delay-off choices, 60, 90, 120 and 150 seconds, which are field adjustable by manipulating the DIP switches on the ST9103 EFT board.

The cooling delay-on and delay-off times are fixed at 30 seconds.

The furnace is protected against over-heating by fixed high temperature limits. These controls are factory set and are not field adjustable. If an over temperature

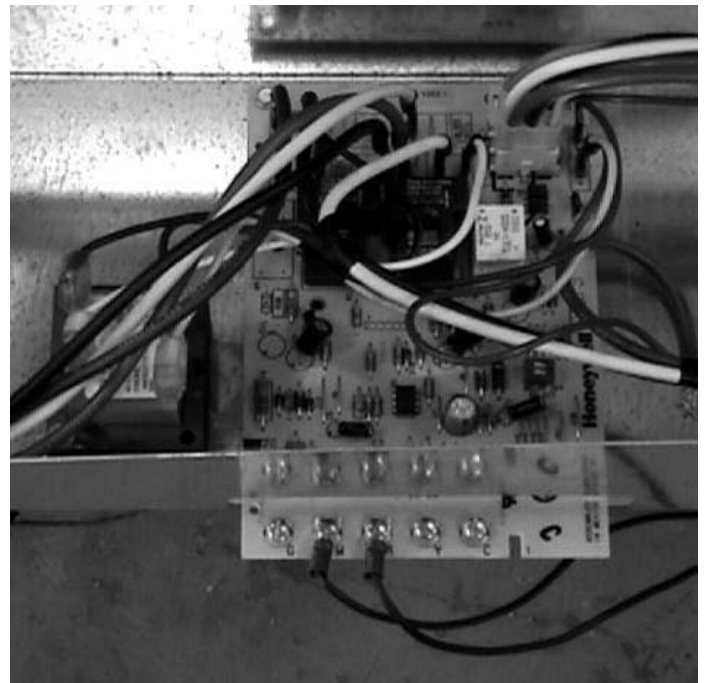

Figure 4: ST9103 EFT

condition is detected, one or both limit switches will interrupt power to the oil primary control, which will shut off the oil burner. The circulating fan will continue to operate. The high limit switches will automatically reset when the furnace returns to a safe temperature.

## 9. ELECTRICAL CONNECTIONS

The furnace is listed by the **Canadian Standards Association (CSA)**. It is factory wired and requires minimal field wiring. In the United States, the wiring must be in accordance with the **National Fire Protection Association NFPA-70, National Electrical Code**, and with local codes and regulations. In Canada, all field wiring should conform to **CAN/CSA C22.1 Canadian Electrical Code, Part 1**, and by local codes, where they prevail.

The furnace should be wired to a separate and dedicated circuit in the main electrical panel; however, accessory equipment such as electronic air cleaners and humidifiers may be included on the furnace circuit. Although a suitably located circuit breaker can be used as a service switch, a separate service switch is advisable. The service switch is necessary if reaching the circuit breaker involves becoming close to the furnace, or if the furnace is located between the circuit breaker and the means of entry to the furnace room. The furnace switch (service switch) should be clearly marked, installed in an easily accessible area between the furnace and furnace room entry, and be located in such a manner to reduce the likelihood that it would be mistaken as a light switch or similar device.

The power requirements for the HO-B Series models are: 120 VAC, 1 Ø, 60 Hz., 12A. 5-ton models: 120 VAC, 1 Ø, 60 Hz., 16A.

Accessories requiring 120 VAC power sources such as electronic air cleaners and humidifier transformers may be powered from the ST9103 EFT. Do not use the direct drive motor connections as a power source, since there is a high risk of damaging the accessories by exposure to high voltage from the auto-generating windings of the direct drive motor.

Thermostat wiring connections and air conditioning contactor low voltage connections are shown in the wiring diagrams. Some micro-electronic thermostats require additional controls and wiring. Refer to the thermostat manufacturer's instructions.

The thermostat should be located approximately 5 feet above the floor, on an inside wall where there is good natural air circulation, and where the thermostat will be exposed to average room temperatures. Avoid locations where the thermostat will be exposed to cold drafts, heat from nearby lamps and appliances, exposure to sunlight, heat from inside wall stacks, etc.

Normal heat anticipator setting: 0.1 A. For more precise adjustment, the heat anticipator may be adjusted to the amperage draw of the heating control circuit as measured between the "R" and "W" terminals of the thermostat. To reduce the risk of damaging the heat anticipator, do not measure circuit without first removing one of the two wires first. To determine the heating circuit amperage draw:

1. Disconnect one of the "R" or "W" wires from the thermostat terminal.
2. Connect an ammeter between the wire and the thermostat terminal to which it was attached.
3. Note the amperage reading when the heating contacts are closed. (System switch must be on "HEAT" if so equipped.
4. Re-connect the thermostat wire. If the thermostat is serving a combination heating and air conditioning system, pay particular attention to polarity.
5. When the thermostat is reconnected and re-plumbed, adjust the heat anticipator setting to match the observed amperage reading.

## 10. HUMIDIFIER

A humidifier is an optional accessory available through most heating supplies outlets. Installation should be carried out in accordance with the humidifier manufacturer's installation instructions. Water or water droplets from the humidifier should not be allowed to come into contact with the furnace heat exchanger. Terminals (115 v) are provided on the ST9103 EFT

control. Do not use direct drive motor connections as a source of power for 120 VAC humidifiers and humidifier transformers.

## 11. OIL TANK

Oil storage tanks must be selected and installed in compliance with applicable codes; in the United States, **NFPA 31**, *Standard for the Installation of Oil Burning Equipment*, Chapter 2. Observe all local codes and by-laws. And in Canada, **CAN/CSA-B139**, *Installation Code for Oil Burning Equipment*, Section 6

In general, the oil tank must be properly supported and remain stable in both empty and full condition. The oil tank must be fitted with vent and supply pipes to the outdoors. Refer to the above-mentioned codes for sizing. The vent pipe must be no less than 1¼ inches I.P.S., and terminate with an appropriate vent cap in a location where it will not be blocked. The fill pipe must be no less than 2 inches I.P.S., and terminate with an appropriate cap in a location where debris will not enter the fill pipe during oil delivery.

If located indoors, the tank should normally be in the lowest level, (cellar, basement, etc.). It must be equipped with a shut-off valve at the tank outlet used for the oil supply. The oil tank must be located as to not block the furnace / room exit pathway. Observe all clearances specified in the above-mentioned codes.

## 12. PIPING INSTALLATION

In the United States the installation must be in accordance with the requirements of NFPA No. 31 and local codes and regulations.

In Canada, the entire fuel system should be installed in accordance with the requirements of CAN/CSA B139, and local regulations. Use only approved fuel oil tanks piping, fittings and oil filters.

Ensure that all fittings used in a copper oil line system are high quality flare fittings. Do not use compression fittings.

Do not use Teflon tape on any fittings.

Pressurized or gravity feed installations must not exceed 3 PSIG. Pressures greater than 10 PSIG may cause damage to the shaft seal. If the height of the oil stored in a tank above the oil burner exceeds 11½ feet, it may be necessary to use a pressure-regulating device approved for this purpose.

The furnaces may be installed with a one-pipe system with gravity feed or lift. The maximum allowable lift on a single line system is 8 feet. Lift should be measured from the bottom (outlet) of the tank, to the inlet of the burner. Sizing a single line system is complex because of the difficulty estimating the pressure drop through each fitting, bend and component in the line. In general, keep single line systems short as possible. If the furnace is to be installed in a suspended position, a two-pipe system may be the better alternative. 2-stage oil pumps are not available for either the Beckett or Riello burner. The following chart shows the allowable line lengths (horizontal + vertical) for single and two stage oil pumps. All distances are in feet.

In retrofit applications, where an existing oil line system is in place, a vacuum check will help determine the efficacy of the existing oil line system. The vacuum in a system featuring a Beckett burner should not exceed 6" Hg. for a single pipe system, nor 12" Hg. for a two-pipe system. The vacuum in a system featuring a Riello burner should not exceed 6" Hg. for a single pipe system, nor 11.44" Hg. for a two-pipe system.

**Table 5: Oil Lines**

Copper Tubing Oil Line Lengths (Feet)				
Beckett Oil Burner				
Lift (feet)	Single-Pipe		Two-Pipe	
	3/8" O.D. Tubing	1/2" O.D. Tubing	3/8" O.D. Tubing	1/2" O.D. Tubing
0	53	100	68	100
1	49	100	65	100
2	45	100	63	100
3	41	100	60	100
4	37	100	58	100
5	33	100	55	100
6	29	100	53	100
7	25	99	50	100
8	21	83	48	100
9	17	68	45	100
10	13	52	42	100
12	---	---	37	100
14	---	---	32	100
16	---	---	27	100
18	---	---	22	88
Riello Oil Burners				
Lift (feet)	Single-Pipe		Two-Pipe	
	3/8" O.D. Tubing	1/2" O.D. Tubing	3/8" O.D. Tubing	1/2" O.D. Tubing
1.5	33	65	100	330
3.0	65	130	80	330
5.0	130	260	65	295
6.5	195	325	50	230
9.5	---	---	25	100
11	---	---	20	65

For additional information, see the installation information sheet included in the documents envelope or affixed to the oil burner.

**NOTE:** Both the Beckett and Riello oil burners require the use of a bypass plug when converting from single-pipe to two-pipe oil piping systems. See burner manufacturer's instructions.

**NOTE:** The Riello oil burner is manufactured with British Parallel Thread pump ports. Adapters are supplied with the oil burner to convert from British Parallel Thread to NPT (National Pipe Thread). Direct connection of NPT fittings to the Riello oil burner ports will result in damage to the pump body. This also applies to pressure and vacuum gauges. (See Riello manual)

### 13. OIL FILTER

All fuel systems should include an oil filter between the fuel oil storage tank and the oil burner. For best results, install the oil filter as close to the burner as possible. When using an indoor oil tank, the oil filter may be installed at the tank downstream from the shut-off valve. If firing the furnace under the 0.65 gph rate, a 7 to 10 micron line filter should be installed as close to the oil burner as possible.

### 14. OIL BURNER NOZZLES

The 80F Series furnace is certified for multiple firing rates, ranging from 58,100 to 78,900 BTU/hr, while the 120F Series Furnace is certified for multiple firing rates of 87,000 113,400 BTU/hr. By changing the oil burner nozzle within the specific Model Range, and temperature rise, the furnace may be fired at an ideal rate for a wide range of structures.

**Table 6: Nozzles (Beckett Oil Burner)**

MODEL	NOZZLE (Delavan)		HEAD
	STD.	ALT.	
80F (060)	0.50/70°W	0.50/80°A	F0
80F (070)	0.65/70°W	0.65/80°A	F3
80F (080)	0.70/70°W	0.70/80°A	F3
120F (090)	0.75/70°W	0.75/80°A	F4
120F (100)	0.80/70°W	0.80/80°A	F4
120F (120)	1.00/70°W	1.00/80°A	F4

### 15. COMBUSTION CHAMBER

This furnace is equipped with an efficient cerafelt combustion chamber. It is held in place by a retaining bracket.

**CHECK THE ALIGNMENT OF THE COMBUSTION CHAMBER AND OIL BURNER BEFORE FIRING. IT IS POSSIBLE FOR THE COMBUSTION CHAMBER TO SHIFT IF SUBJECTED TO ROUGH HANDLING DURING TRANSIT.**

The cerafelt combustion chamber is quite soft initially. After firing, it becomes very brittle. Be sure to do all alignment and positioning adjustments before the first firing.

The combustion chamber should be inspected for damage or carbon build up whenever the oil burner is removed for repairs or routine maintenance.

## **CAUTION**

**BEFORE OPERATING THE FURNACE CHECK BURNER ALIGNMENT WITH COMBUSTION CHAMBER. THE END CONE OF THE AIR TUBE MUST BE CENTRED TO THE ACCOMODATING RING PROVIDED IN THE DESIGN OF THE COMBUSTION CHAMBER. ADJUST ALIGNMENT AND AMULET POSITION (RIELLO BURNER) AS NECESSARY BEFORE FIRST FIRING.**

## 16. BURNER ELECTRODES

Correct positioning of the electrode tips with respect to each other, to the fuel oil nozzle, and to the rest of the burners is essential for smooth light ups and proper operation.

Beckett Oil Burner:

The electrode tips should be adjusted to a gap of 5/32", 1/16" ahead of the nozzle, 5/16" above the centerline of the nozzle. The "Z" dimension (front edge of the burner head to the front face of the nozzle) is 1-1/8 inches.

Riello Oil Burner:

The electrode tips should be adjusted to a gap of 5/32", 3/32" ahead of the nozzle, 13/64" above the centerline of the nozzle.

The electrode porcelains should be free of cracks, the electrode tips should be tapered and free of burrs, and the contact rods must be clean and be in firm contact with the ignition transformer contact springs. The electrodes must not come into contact with the burner head.

## 17. OIL BURNER SET UP

The burner air supply is adjusted to maintain the *fuel to air ratio* to obtain ideal combustion conditions. A lack of air causes "soft" and "sooty" flames, resulting in soot

build-up throughout the heat exchanger passages. Excess combustion air causes a bright roaring fire and high stack temperatures resulting in poor fuel efficiency.

### PREPARATIONS:

Drill a 1/4" test port in the venting, ideally at least 2 flue pipe diameters away from the furnace breeching, if venting horizontally from the furnace, or from the flue pipe elbow if venting vertically before reaching the furnace. (see Figures 5 and 6).

The test port will allow flue gas samples to be taken and stack temperatures to be measured.

Before starting the burner, check the burner alignment with the combustion chamber (fire pot), check that the correct nozzle is tightened into place, and that the burner electrodes are properly positioned. The Beckett burner bulk air band is should be closed, and the air shutter initial setting should be approximately 7.00.

Refer to Table A-2, page 18, for Riello oil burner air damper and turbulator settings.

**Figure 5: Test port location for smoke test horizontal.**

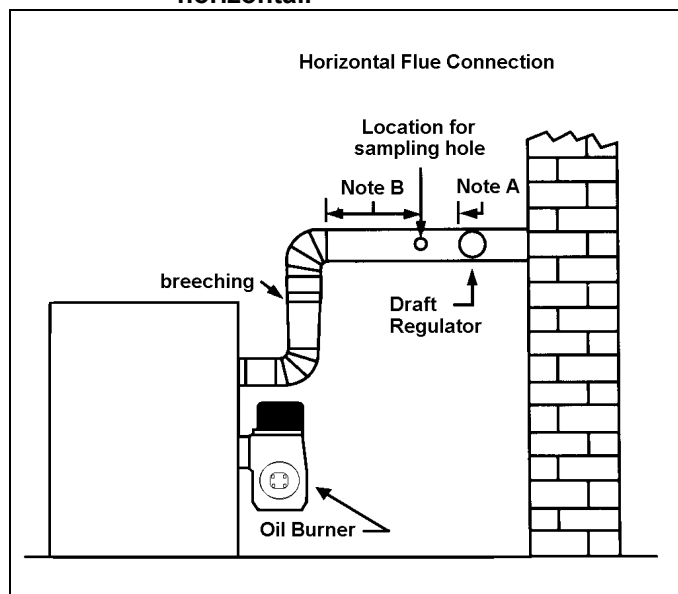

**Note A:** Locate hole at least 6 inches on the furnace side of the draft control.

**Note B:** Ideally, hole should be at least 12 inches from breeching or elbow.

**Figure 6: Test port location for smoke test vertical.**

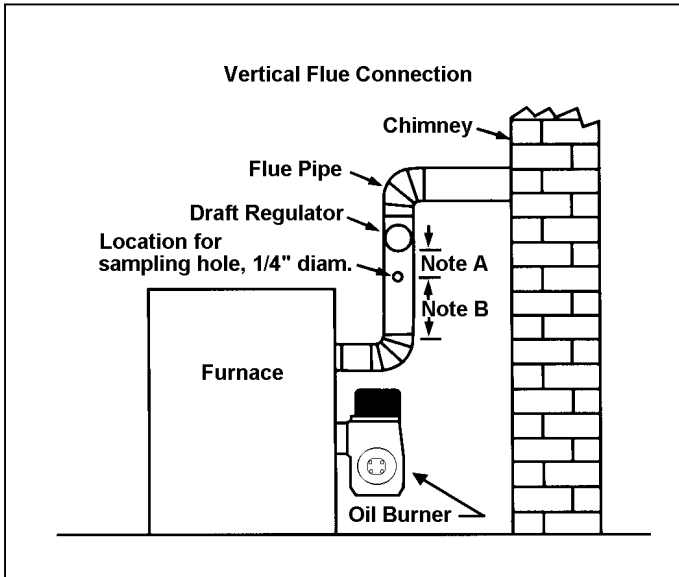

**PROCEDURE:**

Start the burner and allow it to run at least ten minutes. Set the air shutter to give a good flame visually. On Beckett burners, the combustion air supply to the burner is controlled by manipulating the air shutter on the left side of the burner, and, if necessary, the bulk air band. To adjust, loosen the bolt on the movable shutter. Move the shutter gradually until a good flame (visually) has been achieved. Re-slug the bolt.

Refer to the Riello Oil Burner Manual for setting the air adjustment plate.

**Figure 7: Checking Over-Fire Draft.**

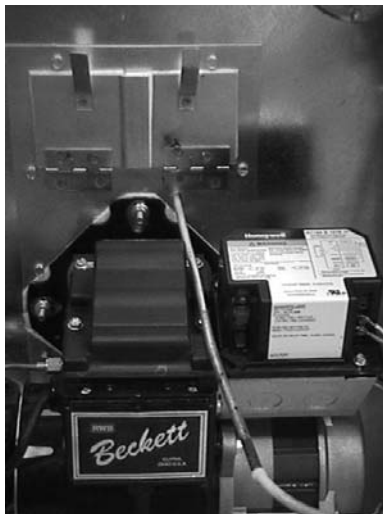

Check the initial draft setting as the furnace warms up. The draft may be measured at the test port. The breech draft should be approximately - 0.05" w.c. to obtain an over fire draft reading of - 0.02 inches w.c.

Check the oil pump pressure. Refer to Table A1, page 18, for pump pressure settings.

After reaching steady state, take a smoke test. If not indicating a trace, set the combustion air controls to provide a trace.

Typically, the CO<sub>2</sub> reading will range between 11.5% to 13.5%.

After the air adjustments have been completed, and the air shutter or air adjustment plate has been secured, take another smoke test to ensure that the values have not changed.

NOTE: Riello Oil Burners - When taking final test readings be sure that the burner cover is in place.

**SMOKE TEST NOTE:**

If oily or yellow smoke spots are found on the smoke test filter paper, it is usually a sign of unburned fuel. This indicates poor combustion. This type of problem may be caused by excess draft, excess air, or contaminated fuel. Do not ignore this indicator.

**STACK TEMPERATURE:**

Stack temperature will vary depending on fuel input, circulating air blower speed, and burner set up, etc. In general, stack temperature should typically range between 380°F to 550°F, assuming that the combustion air is approximately room temperature (65°F - 70°F). In general, lower stack temperature indicates greater efficiency; however, excessively low stack temperature can lead to condensation forming in the chimney and / or venting. Sulphur and similar contaminants in the fuel oil will mix with condensation to form acids. Acids and resultant chemical salts will cause rapid deterioration of the chimney and venting components, and may attack the furnace.

If the flue gases are below the range, it may be necessary to slow down the blower fan. If the flue gases are above the range, the blower fan may require speeding up. Stack temperature varies directly with the system temperature rise. System temperature rise is the difference between the furnace outlet temperature and furnace inlet temperature as measured in the vicinity of the connection between the plenum take-offs and the trunk ducts. Typical temperature rise values range between 60° and 90°F for the Model 80F, 55°F and 85°F for the Model 120F.

If the venting from the furnace to the chimney is long, or exposed to cold ambient temperatures, it may be necessary to use L-Vent as the vent connector to reduce stack temperature loss to prevent condensation. The venting should be inspected annually to ensure that it is intact.

## **! WARNING**

IF THE FURNACE FAILS TO IGNITE, CHECK THE OIL TANK FUEL GAUGE. IF THE FUEL GAUGE SHOWS THAT OIL IS PRESENT, PRESS THE RESET BUTTON ONCE ONLY. IF THE BURNER FAILS TO IGNITE, CONTACT YOUR SERVICE CONTRACTOR.

## **! CAUTION**

ALL FURNACE CONTROLS ARE SENSITIVE AND SHOULD NOT BE SUBJECTED TO TAMPERING. IF PROBLEMS PERSIST, CALL YOUR SERVICE CONTRACTOR.

## **! CAUTION**

DO NOT CONNECT POWER LEADS BETWEEN MOTOR SPEEDS. THE NEUTRAL WIRE MUST ALWAYS BE CONNECTED TO THE MOTOR'S DESIGNATED NEUTRAL TERMINAL.

It is possible and acceptable to use a single blower speed for both heating and cooling modes. The simplest method to connect the wiring from both modes is to use a "piggy-back connector" accommodating both wires on a single motor tap. It is also acceptable to connect the selected motor speed with a pigtail joined to both heating and cooling speed wires with a wire nut. As a safety precaution against accidental disconnection of the wires by vibration, it is advisable to secure the wire nut and wires with a few wraps of electricians tape.

If the joining of the blower speed wiring is done in the furnace junction box, tape off both ends of the unused wire.

### BELT DRIVE

The HO-B Models are available with an optional belt drive blower assembly. Belt drive blower systems can be modified for a variety of speeds and air delivery by adjusting the variable speed motor pulley, and / or by changing the blower pulley.

The variable speed motor pulley may be adjusted by loosening the 5/32 Allen set screw in the outer sheave, and turning the outer sheave clockwise to increase blower speed; counter clockwise to reduce blower speed. Ensure that the setscrew is tightened at one of the "flat spots", failure to do so will convert the variable speed pulley to a fixed speed pulley by ruining the threads. Changing the blower pulley can also modify the blower speed. A smaller blower pulley will cause the blower to turn faster; a larger pulley will reduce blower speed. Large increases in blower speed will increase power requirements. Check the amperage draw of the blower motor after changes have been made. If the amperage draw is greater than the value listed on the motor rating plate, replace with a motor with a higher horsepower rating.

The fan belt tension is very important. There should be a deflection of between  $\frac{3}{4}$  of an inch to 1 inch. Less deflection places a strain on the blower bearings, and increases start up amperage draw. More deflection allows excess slippage and causes premature motor pulley wear. Automotive belt dressings are not recommended. A hard soap such as Sunlight® soap will work well as a belt dressing, for the purpose of reducing belt squeaks, etc. If used, the soap should be applied to the sides of the belt only.

## 18. CIRCULATING AIR BLOWER

### DIRECT DRIVE

The HO-B furnaces may be equipped with a direct drive blower system. Direct drive blower speed adjustments are not normally required in properly sized extended plenum duct systems. The motor RPM and air CFM delivery will vary automatically to accommodate conditions within the usual range of external static pressures typical of residential duct systems. Under-sized duct systems may require a higher blower speed to obtain a reasonable system temperature rise. Some older duct systems were not designed to provide static pressure. They typically feature special reducing fittings at each branch run and lack block ends on the trunk ducts. These systems may require modification to provide some resistance to the airflow to prevent over-amping of the direct drive blower motor. Selecting a lower blower speed may correct this problem.

Direct drive blower speeds are adjusted by changing the "hot" wires to the motor winding connections. Please refer to wiring diagram in Appendix B or the wiring diagram label affixed to the furnace. **THE NEUTRAL WIRE (normally the white wire) IS NEVER MOVED TO ADJUST THE BLOWER SPEED.**

## WARNING

THE BELT DRIVE COMPONENTS OPERATE AT HIGH SPEEDS AND CAN EASILY SNAG LOOSE CLOTHING, CAUSING SERIOUS PERSONAL INJURY. THIS PROCEDURE SHOULD BE LEFT TO TRAINED SERVICE PERSONNEL.

If the blower RPM operates above 1000 RPM, it is advisable to replace the sintered bronze blower bearings with roller Bearings.

The circulating fan start-up is delayed 30 or 45 seconds (depending on EFT) in the heating mode.

The circulating fan start-up is delayed 30 seconds in the cooling mode. The "fan off" is delayed 30 seconds in the cooling mode.

The "fan off" delay may be field adjusted by manipulating the dipswitches. See Figures 8.

Figure 8: Heating Mode "Blower Off" Timings, ST9103

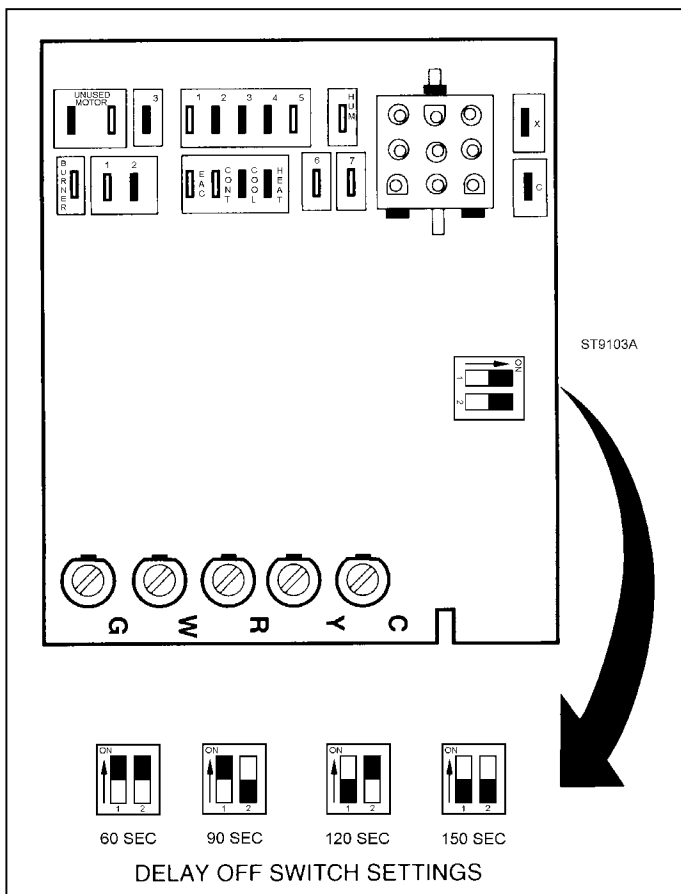

## CAUTION

DISCONNECT THE POWER SUPPLY TO THE FURNACE BEFORE OPENING THE BLOWER ACCESS DOOR TO SERVICE THE AIR FILTER, FAN AND MOTOR. FAILURE TO SHUT OFF POWER COULD ALLOW THE BLOWER TO START UNEXPECTEDLY, CREATING A RISK OF DEATH OR PERSONAL INJURY.

Do not use the blower speed wires as a source of power to accessories as electronic air cleaners and humidifier transformers. The unused motor taps auto-generate sufficiently high voltages to damage accessory equipment. Use the terminals provided on the ST9103 EFT

## CAUTION

DO NOT START THE BURNER OR BLOWER FAN UNLESS THE BLOWER ACCESS DOOR IS SECURELY IN PLACE.

Additional ST9103 Fan Timer Control information is in Appendix A, Tables, and in Appendix B, Wiring Diagrams.

## 19. MAINTENANCE AND SERVICE

### A: Routine Maintenance By Home Owner

Other than remembering to arrange for the annual professional servicing of the furnace by the service or installation contractor, the most important routine service performed by the homeowner is to maintain the air filter or filters. A dirty filter can cause the furnace to over-heat, fail to maintain indoor temperature during cold weather, increase fuel consumption and cause component failure. The furnace filter(s) should be inspected, cleaned or replaced monthly. The furnace is factory equipped with a semi-permanent type filter. If the filter is damaged, replace with filters of the same size and type.

During the routine service, inspect the general condition of the furnace watching for signs of oil leaks in the vicinity of the oil burner, soot forming on any external part of the furnace, soot forming around the joints in the vent pipe, etc. If any of these conditions are present, please advise your service or installation contractor.

## B: Annual Service By Contractor

### **CAUTION**

**THE COMBUSTION CHAMBER (FIREPOT) IS FRAGILE. USE CARE WHEN INSPECTING AND CLEANING THIS AREA.**

The heat exchanger should be inspected periodically and cleaned if necessary. If cleaning is necessary, **SHUT OFF POWER TO THE FURNACE** and remove the burner. Using a stiff brush with a wire handle, brush off scale and soot from inside the drum and flue pipe. To clean the radiator, remove the round covers on the inner radiator access pipes located on the front panel between the oil burner and the flue pipe.

A wire brush can be used to loosen dirt and debris on the inside surfaces of the radiator. Clean out all accumulated dirt, soot and debris with a wire handled brush and an industrial vacuum cleaner. Replace the clean-out covers.

Most circulating fan motors are permanently lubricated by the motor manufacturer. These motors will have no oil ports. If the blower motor does contain oil ports, under normal operating conditions it will not require oiling for the first two years. Oil sparingly; a few drops in each oil port with SAE 20 non-detergent oil. Oiling is most easily done with a "tele-spout" oiler. This oiler has a long flexible plastic spout. **DO NOT OVER-LUBRICATE.** Excess oil may result in premature electric motor failure.

Inspect the blower fan. Clean it if necessary.

Oil Burner Maintenance: Follow the instructions of the oil burner manufacturer. (See oil burner manufacturer's instructions supplied with furnace). The oil burner nozzle should be replaced annually. We recommend that the oil filter be changed on an annual basis.

The venting system should be cleaned and inspected for signs of deterioration. Replace pitted or perforated vent pipe and fittings. The barometric damper should open and close freely.

All electrical connections should be checked to ensure tight connections. Safety controls such as the high limit controls should be tested for functionality. The fan control functions should be checked to ensure that all fan speeds are operating properly.

## 20. FURNACE INSTALLATION SET UP

The furnace must be set up as the final step in the installation.

A) The oil burner must be set up following the procedures outlined in section 17: Oil Burner Set Up.

B) The 80F should operate within a temperature rise of 60°F to 90°F, the 120F; 55°F to 85°F. To determine the temperature rise, measure the supply air and return air temperatures when the furnace has reached steady state conditions. This is the point at which the supply air temperature stops increasing relative to the return air temperature. The furnace may have to run 10 to 15 minutes to reach steady state conditions. The measurements may be made with duct thermometers or thermocouples used in conjunction with multi-meters with temperature measurement capabilities.

The return air should be measured at a point where the thermometer will be well within the air stream near the furnace return air inlet. Actual location is not particularly critical; however, avoid locations where the temperature readings could be affected by humidifier bypass ducts, the inside radius of elbows, etc.

The supply air temperature should be measured at a point where the thermometer will be well within the air stream near the furnace supply air outlet. Usually, the side mid-point of the supply air plenum take-off is ideal, providing it is out of the line of sight to the heat exchanger. If the thermometer is within the line of sight of the heat exchanger, the supply air readings may be skewed by radiant heat from the heat exchanger. If the plenum take-off is unsuitable, the supply air temperature may be measured within the first 18 inches of the first segment of supply air trunk duct.

If the temperature rise is outside the recommended range, it may be adjusted on direct drive equipped units by selecting alternate circulation fan motor speeds, or on belt drive equipped units, by adjusting the variable speed motor pulley or by blower pulley changes. If the temperature rise is too high, speed the fan up. If the temperature rise is too low, slow the fan down.

C) Keep in mind that the stack temperature varies directly with the temperature rise. The higher the temperature rise, the higher the stack temperature will be, resulting in lower efficiency. The lower the temperature rise, the lower the stack temperature will be, which, in some cases, may allow condensation to form in the chimney and other vent parts.

D) Test the high limit control to ensure that it is operating correctly. This may be done by temporarily removing the circulator fan heating wire or neutral wire. On furnaces equipped with belt drive blowers, the fan belt may be temporarily removed. Turn off electrical power to the furnace before working with the motor wires. Be sure to protect any removed wires from shorting out on metal furnace parts. If the high limit test is successful, shut off the electrical power to the furnace, restore the proper



motor wiring, or replace the fan belt. Finally, restore power to the furnace.

E) Operate the furnace through a minimum of three full heating cycles. During this time, check for fuel oil leaks, gross air leakage from the supply air ductwork, unusual noises originating anywhere within the heating system which may cause some concern or annoyance to the home owner, etc.

F) Be sure that the homeowner is familiar with the furnace. The homeowner should be aware of the location of electrical circuit breaker or fuse, the location of any electrical switches controlling the furnace, the location of the oil tank shut-off valve and how to operate the valve. The homeowner should know where the oil tank gauge is located and how to read it.

It would be beneficial to review safety issues with the home owner, such as the danger of storing combustibles too close to the furnace, hanging anything on the furnace vent pipe, and especially the dangers of indiscriminately pressing the burner reset button.

**IMPORTANT:** Be sure that the home owner knows where the burner reset switch is located, and is aware that the reset switch is not to be activated more than once without a look for the cause of the problem, (lack of fuel, etc.). Be sure that the homeowner knows when to quit trying to start the furnace during these conditions and who to call for emergency service.

## 21. OPERATING INSTRUCTIONS

### Before Lighting

Open all supply and return air registers and grilles.  
Open all valves in oil pipes.  
Turn on electric power supply.

### To Light Unit

Set the thermostat above room temperature to call for heat. The burner will start. NOTE: If the furnace has been off for an extended period of time, it may be necessary to press the RESET button on the primary combustion control relay, (once only). If pressing the reset button does not start the furnace, refer to Appendix C, Troubleshooting.

After 30 or 45 seconds (depending on EFT), as the furnace becomes warm, circulation fan will start.

The furnace will continue to run until the thermostat call for heat is satisfied.

Set the thermostat below room temperature. The oil burner will stop.

The air circulation blower will continue to run for 60, 90, 120 or 150 seconds after the oil burner has stopped, depending on the dip switch settings.

### To Shut Down Unit

Set the thermostat to the lowest possible setting.  
Set the manual switch (if installed) in the Electrical Power Supply Line to "OFF".

NOTE: If the furnace is to be shut down for an extended period of time, close the oil supply valve to the oil burner.

<p><b>⚠ WARNING</b></p> <p><b>DO NOT ATTEMPT TO START THE BURNER WHEN EXCESS OIL HAS ACCUMULATED, WHEN THE FURNACE IS FULL OF VAPOUR, OR WHEN THE COMBUSTION CHAMBER IS VERY HOT. NEVER BURN GARBAGE OR PAPER IN THE FURNACE, AND NEVER LEAVE PAPER OR RAGS AROUND THE UNIT.</b></p>
--

### TABLE A-1 BECKETT AFG OIL BURNER SET-UP

BECKETT AFG SERIES OIL BURNERS							
FURNACE MODEL	OUTPUT BTU/Hr	BURNER MODEL	NOZZLE	PUMP PRESSURE	FLOW RATE	HEAD	STATIC PLATE
80F (060)	58,100 <sup>1,2</sup>	AF76BO	0.50 / 70° W	100 PSIG	0.50 GPH	F0	3-3/8 in.
80F (070)	68,000 <sup>2</sup>	AF76BN	0.65 / 70° W	100 PSIG	0.65 GPH	F3	3-3/8 in.
80F (080)	78,900 <sup>2</sup>	AF76BN	0.70 / 70° W	100 PSIG	0.70 GPH	F3	3-3/8 in.
120F (090)	87,700 <sup>2</sup>	AF76BZHS	0.75 / 70° W	100 PSIG	0.75 GPH	F4	3-3/8 in.
120F (100)	98,800	AF76BZHS	0.85 / 70° W	100 PSIG	0.85 GPH	F4	3-3/8 in.
120F (120)	113,400	AF76BZHS	1.00 / 70° W	100 PSIG	1.00 GPH	F4	3-3/8 in.

<sup>1</sup> F0 Head required for proper combustion. <sup>2</sup> Low Firing Rate Baffle required, Beckett Part No. 3708

In the United States, the R. W. Beckett "AFG" Burner may be equipped with Beckett's "Inlet Air Shut-Off", Beckett Part No. AF/A 5861, to increase efficiency. It reduces the amount of air passing through the oil burner, combustion chamber, breeching, etc. up the chimney between burner cycles.

**NOTE: THE USE OF THIS CONTROL CAN OCCASIONALLY CAUSE POST COMBUSTION NOZZLE DRIP.**

### TABLE A-2 RIELLO 40F OIL BURNER SET-UP

RIELLO 40 F SERIES OIL BURNERS							
FURNACE MODEL	OUTPUT BTU/Hr	BURNER MODEL	NOZZLE	PUMP PRESSURE	FLOW RATE	HEAD	STATIC PLATE
80F (060)	58,000	40 F3	0.40 / 60° W	160 PSIG	0.50 GPH	1.5	2.25
80F (070)	73,000	40 F3	0.50 / 60° W	150 PSIG	0.60 GPH	1.5	2.5
80F (080)	79,000	40 F3	0.60 / 60° W	145 PSIG	0.70 GPH	2.0	3.0
120F (090)	87,000	40 F3	0.75 / 70° W	150 PSIG	0.75 GPH	2.0	3.52
120F (100)	100,000	40 F3	0.85 / 70° W	150 PSIG	0.85 GPH	2.5	4.0
120F (120)	118,000	40 F3	1.00 / 70° W	160 PSIG	0.95 GPH	3.0	6.0

**TABLE A-3 DIRECT DRIVE BLOWER SET-UP**

FURNACE MODEL	BLOWER	MOTOR HP	BLOWER SET-UP			COOLING CAPACITY		
			0.20 in. w.c.	0.50 in w.c.	Htg. CFM Range <sup>1</sup>	Tons <sup>2</sup>	MOTOR HP	Clg. CFM Range
			Speed	Speed				
80F (060)	G10 DD	½	Low	Med - Low	629 - 972	3	½	900 - 1150
80F (070)			Med - Low	Med - High	792 - 1223			
80F (080)			Med - High	High	857 - 1324			
120F (090)	G10 DD	½	Med - Low	Med - High	976 - 1508	3	½	800 - 1300
120F (100)			Med - High	High	1084 - 1676			
120F (120)			High	High	1279 - 1977			
120F (090)	G12-10 DD	¾	Low	Low	1106 - 1843	5	¾	1400 - 1870
120F (100)			Med - Low	Med - Low	1229 - 2048			
120F (120)			Med - High	High	1450 - 2417			

(<sup>1</sup>) Heating Range values based on temperature rise. Upper values may exceed measured airflow values in Table A-3. (<sup>2</sup>) Nominal Values Only

**TABLE A-4 DIRECT DRIVE BLOWER CHARACTERISTICS**

Furnace Model	Motor hp	Blower	Temp. Rise (ΔT)	Motor FLA	Speed	CFM					
						External Static Pressure - inches w.c.					
						0.20	0.30	0.40	0.50	0.60	0.70
80F	½	G10 DD	60° - 90°F	7.7	High	1368	1298	1223	1144	1046	938
					Med-High	1318	1256	1178	1108	1007	909
					Med-Low	1173	1132	1071	993	909	816
					Low	856	833	791	748	692	610
120F	½	G10 DD	55° - 85°F	7.7	High	1604	1527	1446	1360	1245	1092
					Med-High	1507	1425	1338	1270	1171	1035
					Med-Low	1172	1146	1119	1064	977	879
					Low	810	771	731	690	645	597
120F	¾	GT12-10 DD	45° - 75°F	12.5	High	1957	1911	1846	1797	1729	1658
					Med-High	1764	1730	1695	1640	1584	1526
					Med-Low	1677	1658	1603	1565	1506	1424
					Low	1446	1446	1446	1404	1315	1245

**TABLE A-5 BELT DRIVE BLOWER SET-UP**

Model HO-B	Blower	Motor hp	Fan Belt	Blower Set-Up						Cooling Capacity	
				0.20 in. w.c.			0.50 in. w.c.			Tons	CFM Range
				Pulley			Pulley				
Bonnet Output (BTUH)	Blower	Motor	Turns Out	Blower	Motor	Turns Out					
80 (60,000)	G10	½	4L360	5 x ¾	¾ x ½	3	5 x ¾	¾ x ½	2	3	1000 - 1300
80 (70,000)						2			1		
80 (80,000)						2			1		
120 (90,000)	G10	½	4L360	5 x ¾	¾ x ½	3	5 x ¾	¾ x ½	2	3	1000 - 1500
120 (100,000)						3			1		
120 (120,000)						2			0		

**TABLE A-6 BELT DRIVE BLOWER CHARACTERISTICS**

Furnace Model	Motor hp	Blower	Temp. Rise (ΔT)	Motor FLA	Motor Pulley Turns Out	CFM					
						External Static Pressure - inches w.c.					
						0.20	0.30	0.40	0.50	0.60	0.70
80F	½	G10	60° - 90°F	5.8	0	1596	1518	1435	1330	1247	1184
					1	1505	1434	1347	1220	1081	993
					2	1567	1453	1291	1125	996	817
					3	1429	1332	1180	1064	818	558
120F	½	G10	55° - 85°F	5.8	0	1832	1747	1658	1546	1446	1338
					1	1694	1603	1507	1382	1245	1119
					2	1566	1467	1339	1196	1064	880
					3	1383	1270	1120	1006	771	545

**TIP:**

These formulae will assist with the design of the ductwork and the determination of airflow delivery:

$$CFM = \frac{Bonnet\ Output}{(1.085 \times System\ Temperature\ Rise)}$$

$$System\ Temperature\ Rise = \frac{Bonnet\ Output}{(1.085 \times CFM)}$$

# GENERAL DIMENSIONS

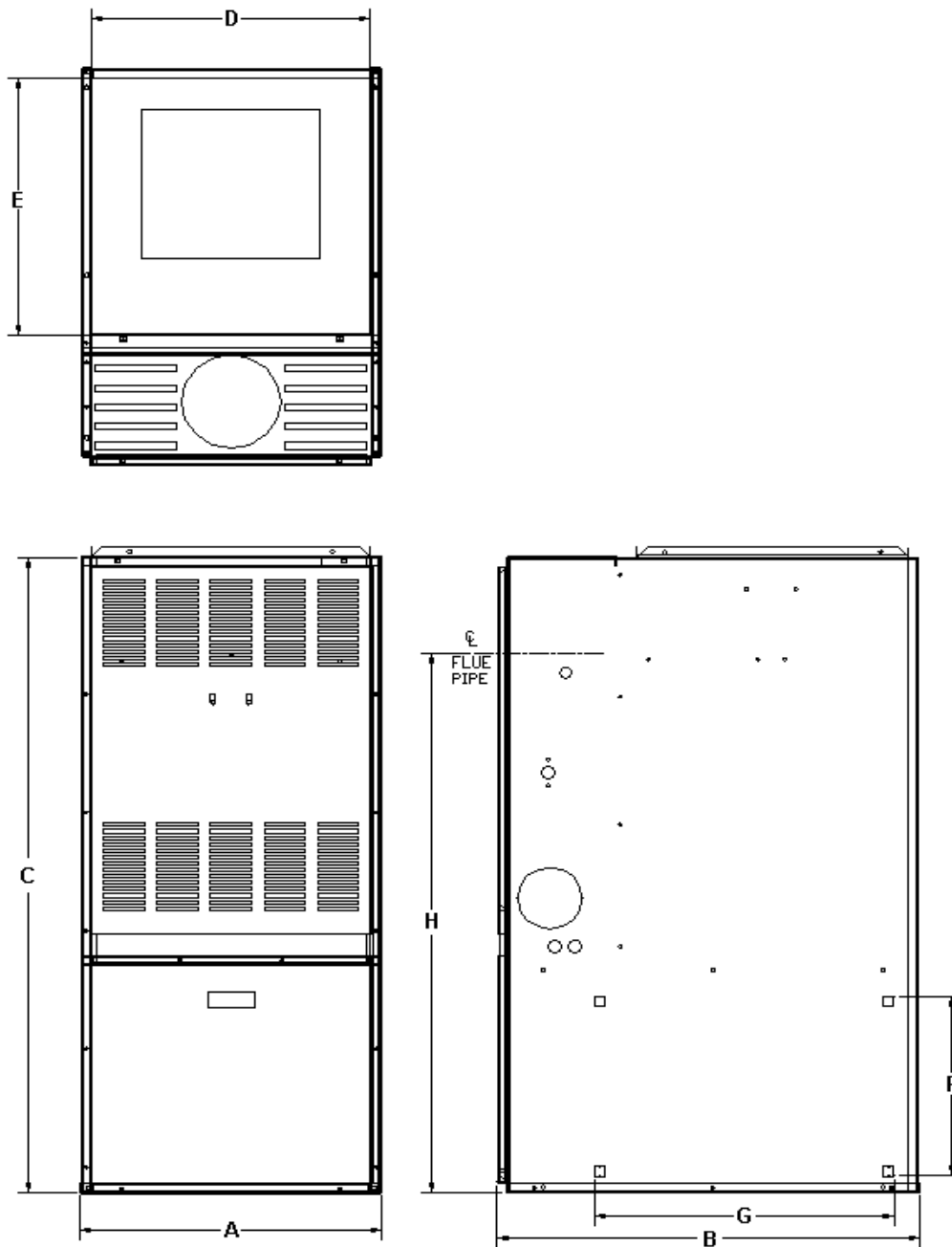
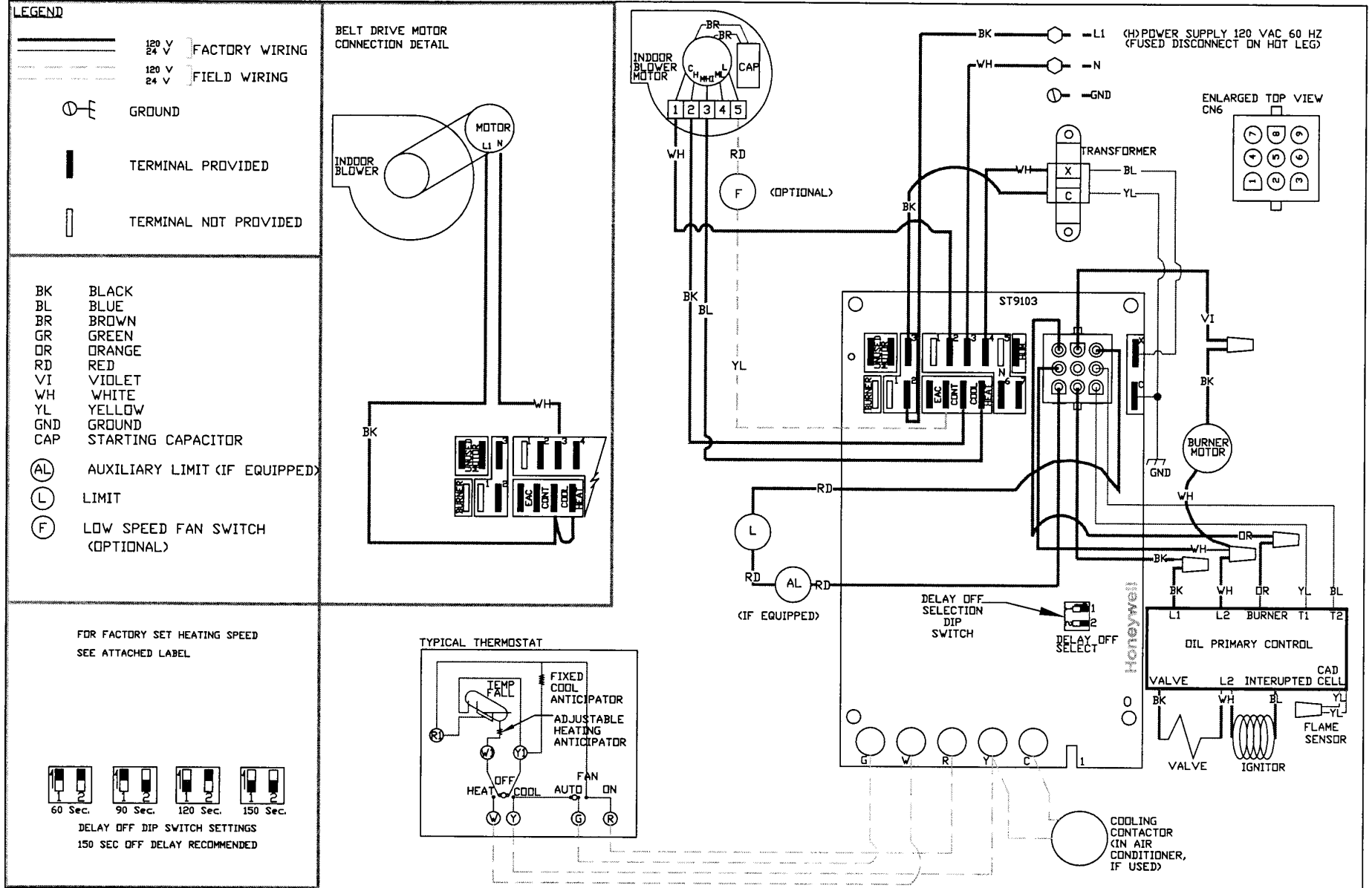

**Table A-6: General Dimensions (inches)**

Cabinet			Plenum Openings			Flue		Filter (Perm.)	Ship Weight (lb)
			Supply Air	Return Air		Dia.	Height H		
Width A	Depth B	Height C	D x E	Side F x G	Bottom				
<b>80F</b>									
22	31	49-1/2	20 1/2 x 20	14 x 22	14 x 22	5	42	16 x 25 x 1	190
<b>120F</b>									
22	31	58-1/8	20 1/2 x 20	14 x 22	14 x 22	6	46-1/2	16 x 25 x 1	270

# Appendix B WIRING

## WIRING DIAGRAM: OIL FURNACE WITH ST9103 EFT & R7184 CONTROL



# Appendix B WIRING

## WIRING DIAGRAM: OIL FURNACE WITH ST9103 EFT & RIELLO OIL BURNER

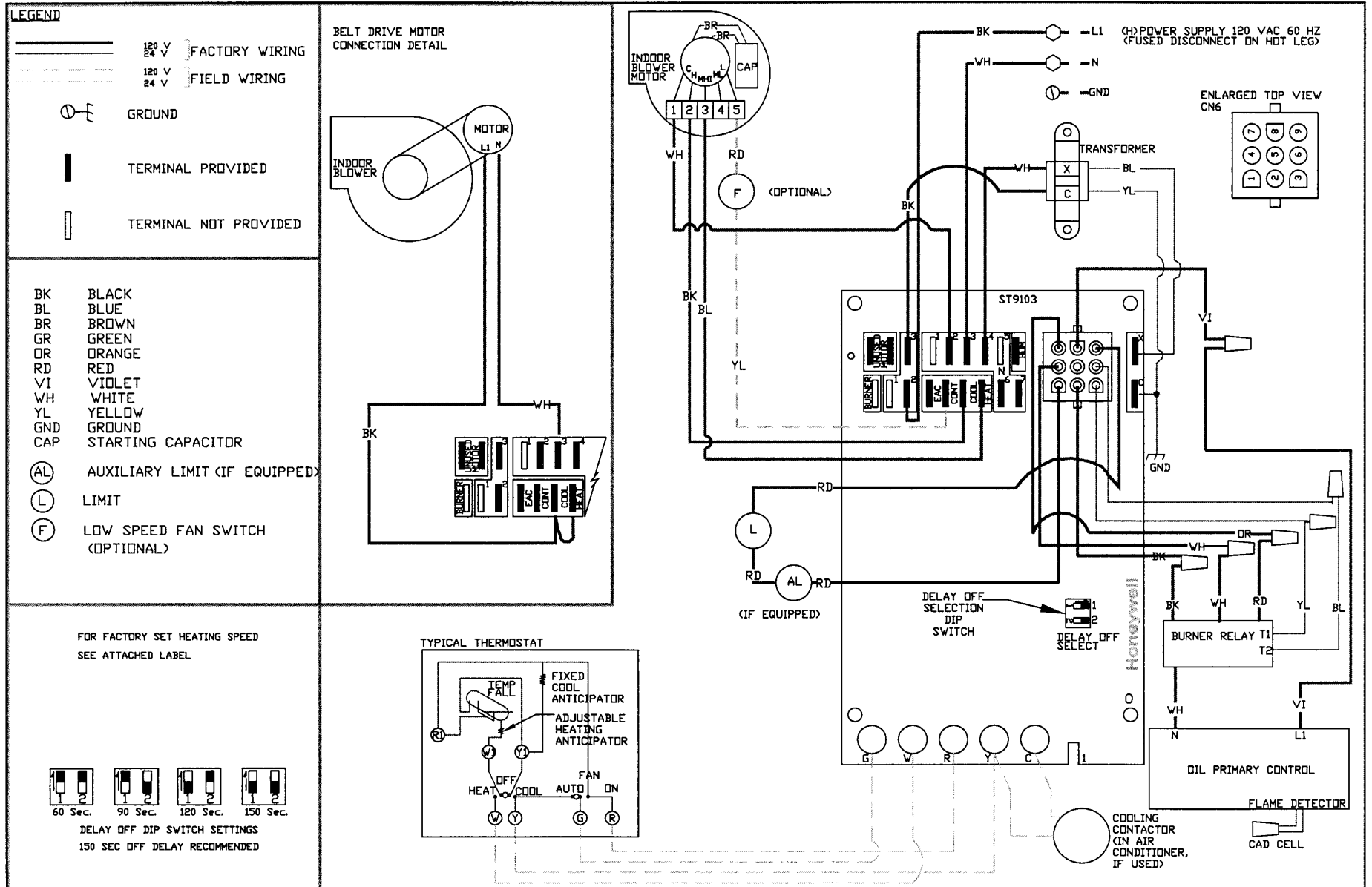

## WIRING NOTES:

### HO-B SERIES OIL FURNACE

#### CONTINUOUS FAN OPERATION:

The ST9103 EFT has provisions to run the blower motor continuously on a speed lower than the cooling or heating speeds. On a call for cooling, the fan motor will switch to cooling speed, and on a call for heating, the fan will switch to heating speed, each over-riding the continuous low speed fan.

To obtain continuous low speed fan, route a 16 gauge stranded, type TEW, 105°C wire from the CONT Terminal on the ST9103 EFT to the low speed or medium low speed motor terminal. Both wire ends will require ¼ inch quick connects, (also known as "Faston" connectors or ¼" spade connectors). For additional control over the continuous low speed fan circuit, a SPST toggle switch may be wired in series between the motor terminal and the ST9103 terminal. The continuous low speed fan operation operates at 115 vac. Use appropriate wiring methods to prevent electrical shock.

## **⚠ WARNING**

**TURN OFF ELECTRICAL POWER TO THE FURNACE WHEN SERVICING OR ALTERING FURNACE WIRING.  
FAILURE TO DO SO MAY RESULT IN SEVERE PERSONAL INJURY, PROPERTY DAMAGE OR DEATH.**

#### ACCESSORIES:

The ST9103 EFT has provisions for supplying 115 volt power to an electronic air cleaner (EAC) as well as 115 volts to a line voltage humidifier or humidifier step down transformer. Both sets of terminals are ¼ inch quick connect type, rated at 1 A each.

The EAC terminals provide power to an electronic air cleaner whenever the heating or cooling speeds are activated. Power is not provided when the continuous speed is activated. If the electronic air cleaner must run during continuous low speed fan operation, wire the EAC into the furnace L1 terminal.

NOTE: It is seldom advisable to operate an electronic air cleaner at the continuous low speed because of the potential for excess ozone generation.

The HUM terminals provide power to a line voltage humidifier or humidifier step down transformer when the oil burner motor is operating.

#### THERMOSTAT HEATING CONNECTIONS:

The thermostat connections "R" and "W", or "RH" and "W" connect to the "R" and "W" screw terminals shown on the left hand side of Figure 10, on the ST9103 EFT located in the control box mounted to the blower mounting rails.

Figure 9: Thermostat Connections ST9103

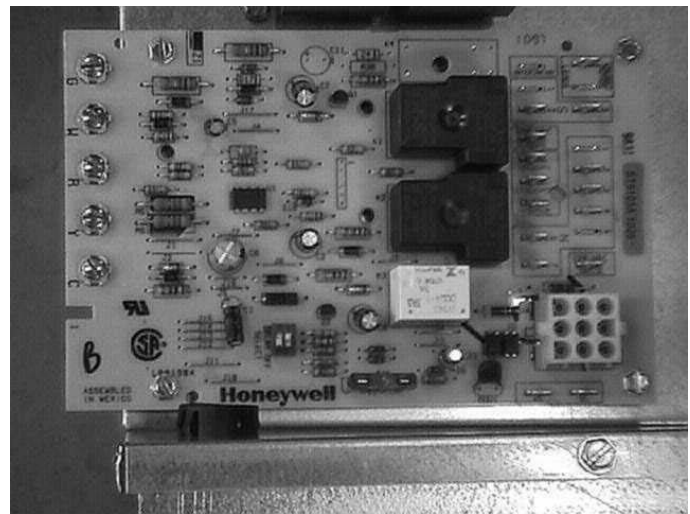

NOTE: All thermostat wires for both heating and cooling connect to the furnace at this point. A factory installed wiring harness connects the heating control functions to the R7184 oil primary control.

Figure 8, page 14, shows the detail of the timed "Blower Off" dipswitch settings. Figure 10 shows the dipswitch location along the bottom edge of the control board, just above the "Honeywell" label.



## Appendix C

### TROUBLESHOOTING

#### R7184 DETAILED SEQUENCE OF OPERATION

Power is applied to unit. The R7184 completes a self-diagnostic procedure. If no light or flame is present, and unit passes its self-diagnostic procedure, the control enters into the idle mode.

*Thermostat calls for heat:*

- A. Safety check is made for flame (4 second delay).
  1. When flame is not present, the R7184 will apply power to the burner motor and igniter.
  2. When flame is present, the control remains in the idle state.
- B. Unit enters and completes a pre-purge period of 15 seconds, then applies power to the solenoid valve.
- C. Control enters the trial for ignition state.
- D. Control monitors the burner flame.
  1. When flame is present, the control enters ignition carryover state. (Continues to spark for 10 sec.).
    - a. Provides continuous spark after flame is sensed to assure that burner remains lit.
    - b. Turns on LED diagnostic light.
    - c. Starts carryover timer.
      - i. Flame and call for heat are monitored.
        - If flame is lost and lockout timer has not expired, R7184 will return to trial for ignition state.
        - If flame is lost and lockout timer has expired, R7184 will enter the recycle state.
          - ◆ Recycle timer starts.
          - ◆ Burner motor and igniter and solenoid valve are turned off.
          - ◆ LED diagnostic light flashes slow.
          - ◆ Returns to idle state when recycle timer expires (60 seconds).
- E. Carryover timer expires.
  - i. Enters run state.
    - Igniter turns off.

*Combustion continues until thermostat is satisfied, or R7184 detects a loss of flame and enters into Recycle Mode.*

*Thermostat is satisfied - call for heat is terminated:*

- R7184 shuts off burner motor and solenoid valve.
- LED diagnostic light is off.
- R7184 returns to idle state.

Please see flow chart on page 26.

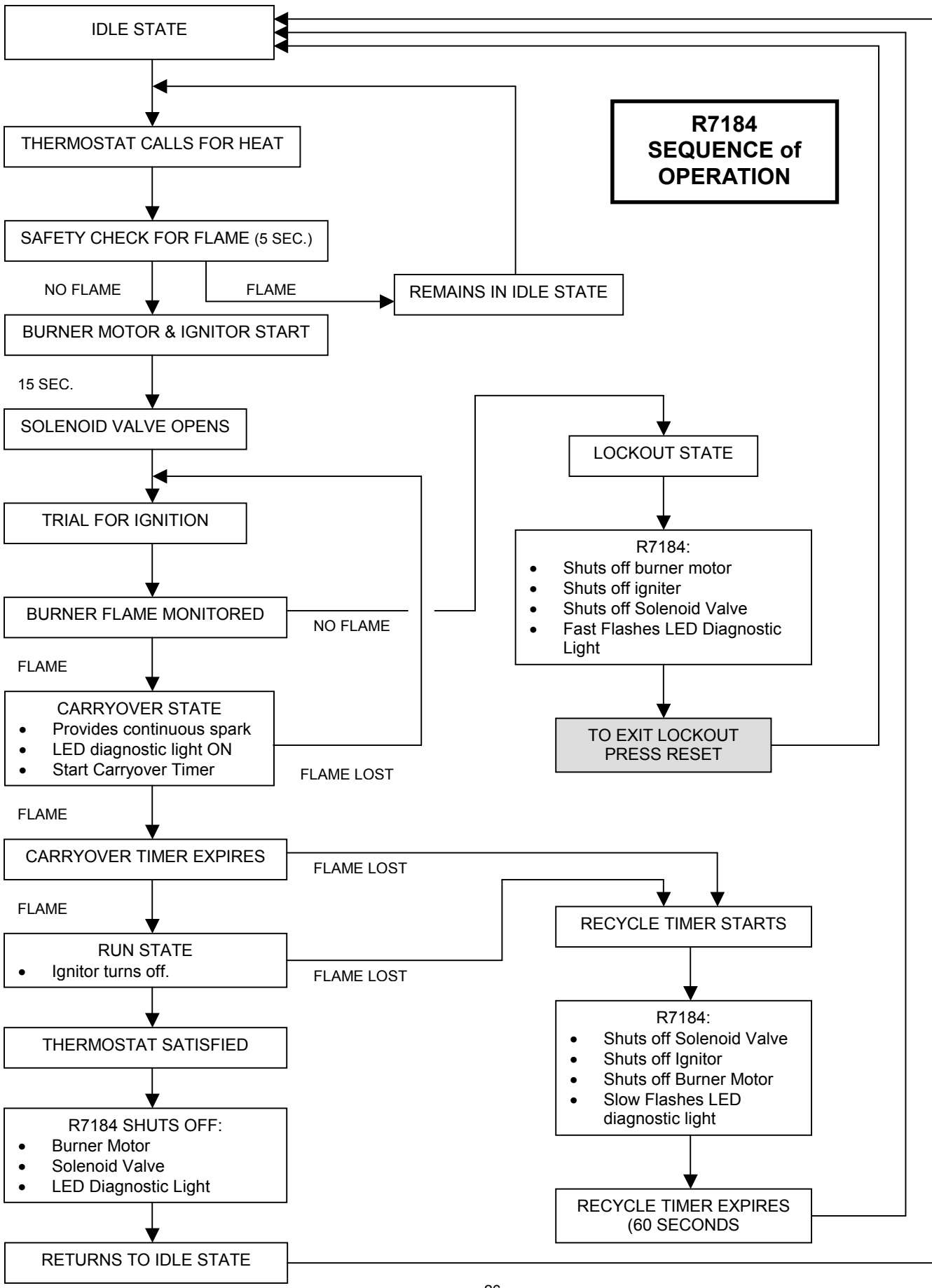

# RIELLO 40F3 TROUBLESHOOTING CHART

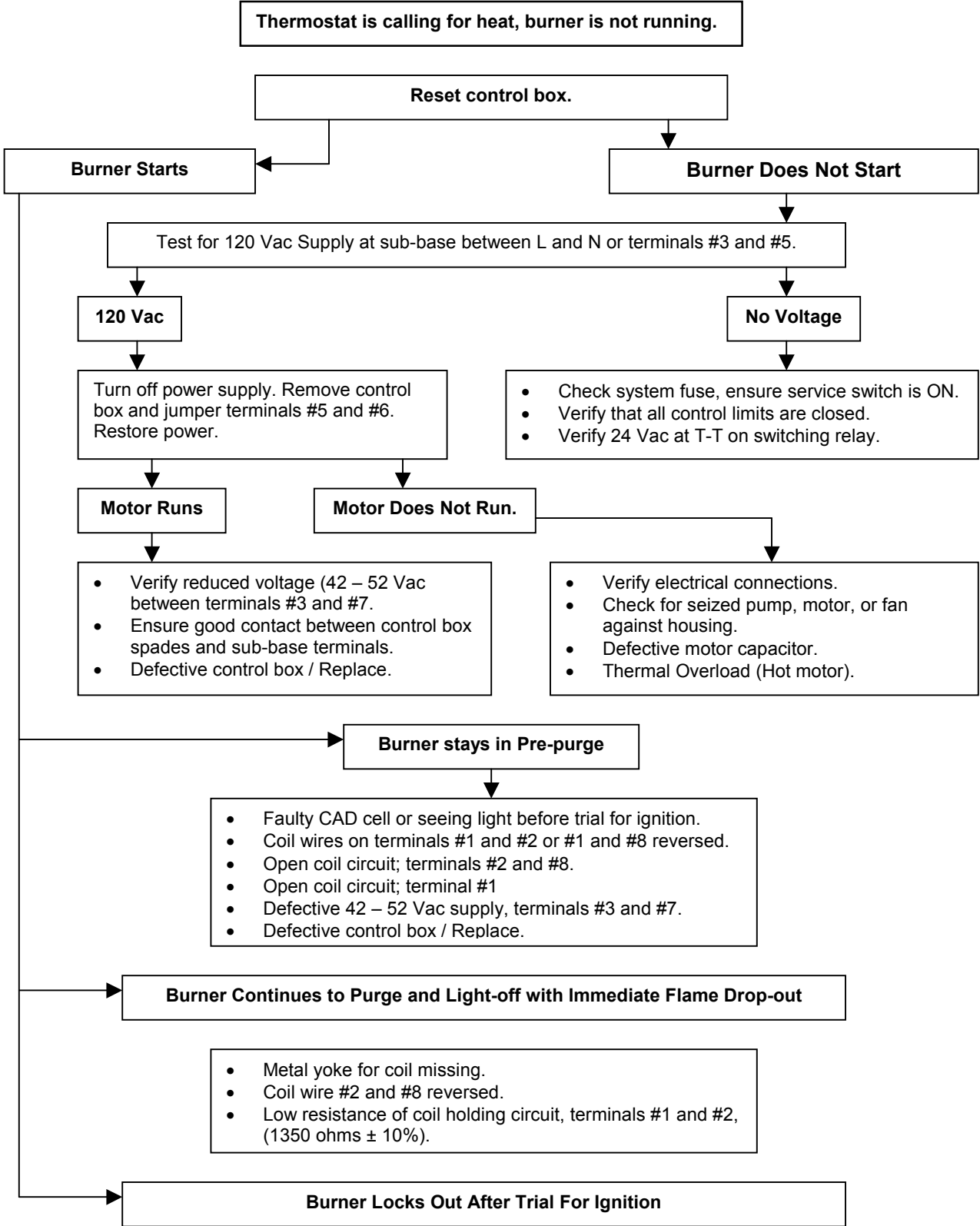

Continued on next page.

### Burner Locks Out After Trial For Ignition

- Low resistance or no contact on starting circuit of coil, terminals #2 and #8. (1.3 ohm  $\pm$  %).
- No oil supply – tank empty, valve closed, dirty filter, damaged supply lines.
- Defective or dirty oil valve stem, nozzle, or pump strainer.
- Broken pump drive key, defective pump, no oil pressure.
- Ignition electrodes shorted, cracked porcelain.
- Burner motor not up to speed.
- Excessive draft over fire.
- Defective control box / Replace.

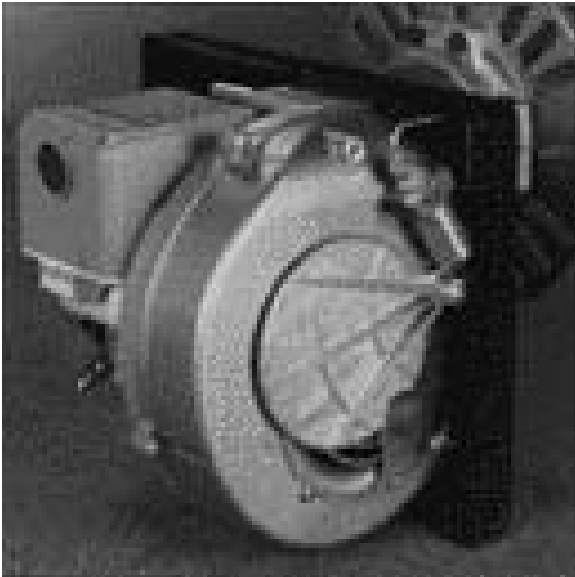

Riello Oil Burner Automatic Air Shutter.

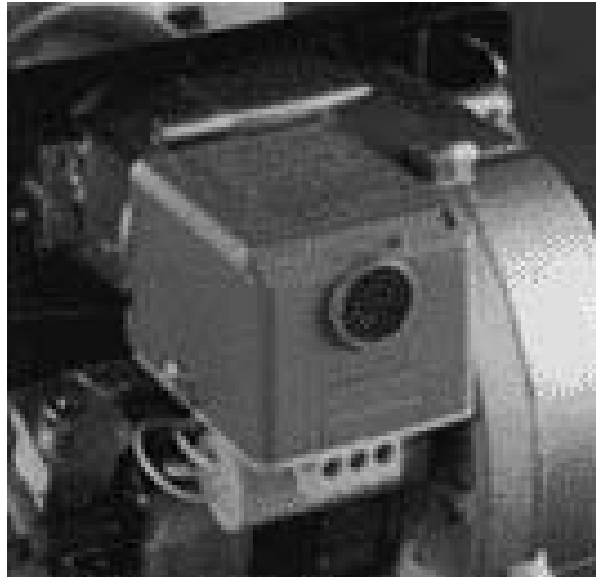

Riello Oil Burner Electronic Ignition Control.

**TABLE C-1: ST9103 DETAILED SEQUENCE OF OPERATION**

Mode	Action	System Response
HEAT	Thermostat calls for heat. ("W" terminal is energized).	<ul style="list-style-type: none"> <li>a. ST9103 closes oil primary control T - T connections).</li> <li>b. Ignition system and R7184 oil primary control start the furnace. Oil flows as long as the oil primary control senses flame.</li> <li>c. Burner motor is energized and heat "fan on" delay timing begins. When timing is complete (30 seconds), the circulator fan is energized at heat speed.</li> </ul>
	Thermostat ends call for heat. ("W" terminal is de-energized).	<ul style="list-style-type: none"> <li>a. R7184 oil primary control is de-energized, terminating the burner cycle.</li> <li>b. Heat "fan off" delay timing begins. Length of delay depends on ST9103 dip switch settings. When timing is complete, the circulator fan is de-energized.</li> <li>c. ST9103 returns to standby mode, (Oil primary control and circulator fan are off, unless continuous fan operation is selected at the thermostat).</li> </ul>
	Burner fails to light.	<ul style="list-style-type: none"> <li>a. Oil primary control locks out within lockout timing, (30 seconds).</li> <li>b. Burner motor is de-energized. (even though thermostat is still calling for heat).</li> <li>c. If circulator fan has started, it continues through the selected heat "fan off" delay period.</li> </ul>
	Established flame fails.	<ul style="list-style-type: none"> <li>a. Burner motor is de-energized and oil primary control goes into recycle mode.</li> <li>b. If the selected heat "fan off" delay timing is longer than the recycle delay timing, the circulator fan continues to run through the next trial for ignition.</li> </ul>
COOL	Thermostat begins call for cool. (G and Y terminals are energized).	<ul style="list-style-type: none"> <li>a. Cooling contactor is energized immediately.</li> <li>b. Circulator fan is energized at cool speed.</li> </ul>
	Thermostat ends call for cool. (G and Y terminals are de-energized).	<ul style="list-style-type: none"> <li>a. Cooling contactor is de-energized immediately.</li> <li>b. Circulator fan turns off immediately.</li> </ul>
FAN	Thermostat begins call for fan. (G terminal is energized).	<ul style="list-style-type: none"> <li>a. Circulator fan is energized immediately at cooling speed.</li> </ul>
	Thermostat ends call for fan. (G terminal is de-energized).	<ul style="list-style-type: none"> <li>a. Circulator fan is de-energized immediately.</li> </ul>
LIMIT	Limit switch string opens.	<ul style="list-style-type: none"> <li>a. Oil primary control shuts off burner.</li> <li>b. Circulator fan is energized immediately at heat speed.</li> <li>c. ST9103 opens oil primary control T - T connections.</li> </ul>

*Continued on following page.*

Continued from last page

Mode	Action	System Response
LIMIT	Limit switch string opens. ( <i>continued</i> )	d. Circulating fan runs as long as limit string stays open. If there is a call for cooling or fan, the circulating fan switches from heating to cooling speed.
	Limit switch string closes (with existing call for heat).	a. ST9103 begins heat "fan off" delay sequence. b. Circulating fan turns off after the selected heat "fan off" timing. c. ST9103 re-closes oil primary control T - T connections. d. Oil primary control is energized, initiating burner light-off.
	Limit switch string closes (without existing call for heat).	a. Circulator fan turns off when heat "fan off" delay time is complete. b. Normal operation resumes; ST9103 control is in standby mode awaiting next thermostat command.
FAN	Continuous circulating fan is connected.	a. Circulating fan is energized when there is no call for heat, cool, or fan. b. If fan operation is required by a call for heat, cool, or fan, the ST9103 switches off the continuous fan speed tap before energizing the other fan speed.
EAC	Electronic Air Cleaner is connected.	<ul style="list-style-type: none"> <li>• Electronic air cleaner (EAC) connections are energized when the heat or cool speed of the circulator fan is energized. EAC connections are not energized when the optional continuous fan terminal is energized.</li> </ul>
HUM	Humidity control is connected.	<ul style="list-style-type: none"> <li>• Humidifier connections are energized when the oil burner motor is energized.</li> </ul>

## R7184 LED DIAGNOSTIC LIGHT

The LED diagnostic light has several functions. It indicates the state or mode in which the oil burner is operating. It will also indicate fault conditions, and help determine cad cell resistance while the burner is operating.

### NORMAL CONDITIONS:

The LED diagnostic light will turn on when the burner enters the carryover state; the point at which ignition spark is on, and will remain on through the run state, where the ignition spark is terminated but the burner continues to fire.

The LED diagnostic light will turn off at the end of the burner cycle as the R7184 enters the idle state, and will remain off until the next heating cycle.

### FAULT CONDITIONS:

If the LED diagnostic light is flashing quickly; 1 Hz ( $\frac{1}{2}$  second on /  $\frac{1}{2}$  second off), the R7184 is in the lockout state or in restricted mode. To exit the lockout state, press the reset button.

If the LED diagnostic light is flashing slowly;  $\frac{1}{4}$  Hz (2 seconds on / 2 seconds off), the R7184 is in the recycle state. This indicates that flame sensing was lost after the lockout timer expired during the ignition carryover state. The R7184 will return to the idle state within 60 seconds.

### CAD CELL CONDITION:

If the LED diagnostic light is off, the cad cell is not sensing flame.

If the LED diagnostic light is on, the cad cell is sensing flame, or viewing ambient light.

The resistance of the cad cell may be checked while the R7184 is in the run state by pressing the reset button. The LED diagnostic light will flash the following code:

**TABLE C-2: CAD CELL RESISTANCE**

Flashes	Resistance in Ohms
1	Less than 400
2	Between 400 - 800
3	Between 800 - 1600
4	Between 1600 - 5000

## Troubleshooting

### IMPORTANT:

**Due to the potential hazard of line voltage, only a trained, experienced service technician should perform the troubleshooting procedure.**

### PRELIMINARY STEPS:

Check the diagnostic light for indications of burner condition. Refer to R7184 LED DIAGNOSTIC LIGHT section for details.



When simulating a call for heat at the R7184, disconnect at least one thermostat lead wire from the T1 - T2 terminals to prevent damage to the thermostat. Neglecting this procedure may burn out the heat anticipator of a standard 24 VAC thermostat, or cause harm to components within a micro-electronic thermostat.

Before checking the oil primary control, perform these preliminary checks, (repair or replace controls as necessary):

- check the power supply; fuse box or breaker, any service switches, all wiring connections, and burner motor reset button (if equipped).
- check the limit switches to ensure that the switch contacts are closed.
- check the electrode gap and position.
- check the contacts between the oil primary control and the electrodes.
- check oil supply (tank gauge).
- check the oil nozzle, oil filter, and oil valves.
- check the piping or tubing to the oil tank.
- check the oil pump pressure.

CHECK OIL PRIMARY CONTROL AND IGNITOR

If the trouble does not appear to be in the burner or ignition hardware, check the oil primary control and the ignitor by using the following equipment:

- ◇ screwdriver.
- ◇ voltmeter (0 - 150 VAC)
- ◇ insulated jumper wires with both ends stripped.



**Electrical Shock Hazard.**

Troubleshooting is done with the system powered. Be careful to observe all necessary precautions to prevent electrical shock or equipment damage.

**Preliminary Checks:**

1. Make sure that limit switches are closed and that contacts are clean.
2. Check for line voltage power on the oil primary control black and white lead wires.
3. Refer to Table C-4 or C-5 for further troubleshooting information.

**TABLE C-3: R7184 TROUBLESHOOTING**

**Condition: Burner motor does not start when there is a call for heat.**

Procedure	Status	Corrective Action
1. Check that limit switches are closed and contacts are clean. This includes the burner motor reset button.	N/A	N/A
2. Check for line voltage power at the oil primary control. Voltage should be 120 Vac between the black and white lead wires on the oil primary control.	N/A	N/A
3. Check indicator light with burner off, no call for heat (no flame).	Indicator light is on.	Cad cell is defective, sees external light, or connections have shorted. Go to step 4.
	Indicator light is off.	Go to step 5.
4. Shield cad cell from external light.	Indicator light turns off.	Eliminate external light source or permanently shield cad cell.
	Indicator light stays on.	<ul style="list-style-type: none"> <li>• Replace cad cell with new cad cell and recheck.</li> <li>• If indicator light does not turn off, remove yellow leadwires from R7184 and recheck.</li> <li>• If indicator light is still on, replace the R7184 control.</li> <li>• If the indicator light turns off, replace cad cell bracket assembly.</li> </ul>

- *continued on following page*



• **Table C-3: R7184 Troubleshooting** *continued from previous page*

Procedure	Status	Corrective Action
5. Jumper thermostat (T -T) terminals on R7184  <b>IMPORTANT</b> First remove one thermostat lead wire.	Burner starts.	Trouble is in thermostat circuit. Check thermostat wiring connections. If connections are clean and tight, check thermostat wires for continuity.
	Burner does not start.	<ul style="list-style-type: none"> <li>• Disconnect line voltage power and open line switch.</li> <li>• Check all wiring connections.</li> <li>• Tighten any loose connections and recheck.</li> <li>• If burner still doesn't start, replace R7184</li> </ul> If burner still doesn't start, check the oil burner motor. It may be seized or burned out.
<b>Condition: Burner starts then locks out on safety with indicator light flashing at 1 Hz rate (½ second on, ½ second off)</b>		
Procedure	Status	Corrective Action
1. Check that the limit switches are closed and contacts are clean.	---	---
2. Check for line voltage power at the oil primary control. Voltage should be 120 vac (nominal)	---	---
3. Check indicator light with burner off, no call for heat (no flame).	Indicator light is on.	Cad cell or controller is defective, sees external light, or connections are shorted. Go to step 4.
	Indicator light is off.	Go to step 5.
4. Shield cad cell from external light.	Indicator light turns off.	Eliminate external light source or permanently shield cad cell.
	Indicator light stays on.	<ul style="list-style-type: none"> <li>• Replace cad cell with new cad cell and recheck.</li> <li>• If indicator light does not turn off, remove cad cell leadwires from R7184 and recheck.</li> <li>• If indicator light turns off, replace cad cell bracket assembly.</li> <li>• If indicator light does not turn off, replace controller.</li> </ul>

*Continued on next page*

**Table C-3: R7184 Troubleshooting** *continued from previous page*

Procedure	Status	Corrective Action
5. Jumper thermostat (T -T) terminals on R7184  <b>IMPORTANT</b> First remove one thermostat lead wire.	Burner starts.	Trouble in thermostat or limit circuit. Check thermostat or limit wiring connections.
	Burner does not start.	<ul style="list-style-type: none"> <li>• Disconnect the line voltage power and open line switch.</li> <li>• Check all wiring connections.</li> <li>• Tighten any loose connections and recheck.</li> <li>• If burner does not start, replace R7184</li> </ul>
<b>Condition: Burner starts then locks out on safety with indicator light flashing at 1 hz rate (½ second on, ½ second off)</b>		
6. Reset oil primary control by pushing in and releasing red reset button.	Indicator light stops flashing.	Go to Step 7.
	Indicator light continues to flash at 1 Hz rate.	Verify that the control is not in restricted mode. (See notes at end of this table.). If not in restricted mode, replace R7184
7. Listen for spark after burner turns on (after 2 second delay).	Ignition is off	Spark ignitor could be defective. Check for line voltage at ignitor terminals. If line voltage is present, replace R7484.
	Ignition is on.	Go to Step 8.
	Ignition is on but no oil is being sprayed into the combustion chamber.	Wait for "Valve ON" delay to complete. Check oil supply, and oil line valve. Check for filter blockage or seized oil pump.
8. Check indicator light after flame is established, but before oil primary control locks out.	Indicator light is on until the control locks out and starts flashing during lockout.	Replace R7184
	Indicator light stays off.	Go to step 9.

*Continued on next page*

**Table C-3: R7184 Troubleshooting** *continued from previous page*

Procedure	Status	Corrective Action
<p>9. Check cad cell sighting for view of flame.</p> <ul style="list-style-type: none"> <li>• Disconnect line voltage power and open line switch.</li> <li>• Unplug cad cell and clean cad cell face with soft cloth. Check sighting for clear view of flame. Replace cad cell in socket.</li> <li>• Reconnect line voltage power and close line switch.</li> <li>• Start burner.</li> </ul>	Burner locks out.	Go to step 10.
	Burner keeps running.	System is OK.
<p>10. Check cad cell.</p> <ul style="list-style-type: none"> <li>• Disconnect line voltage power and open line switch.</li> <li>• Remove existing cad cell and replace with new cad cell.</li> <li>• Disconnect all wires from thermostat terminals to ensure that there is no call for heat.</li> <li>• Reconnect line voltage power and close line switch.</li> <li>• Expose new cad cell to bright light such as a flashlight.</li> </ul>	Indicator light is on.	Remount control onto burner housing. Go to step 6.
	Indicator light is off.	Go to step 11.

*Continued on next page.*

**Table C-3: A Troubleshooting** *continued from previous page.*

Procedure	Status	Corrective Action
11. Check cad cell bracket assembly. <ul style="list-style-type: none"> <li>• Disconnect line voltage power and open line switch.</li> <li>• Remove cad cell wires from quick connect connectors on the and leave control leadwires open.</li> <li>• Apply power to device.</li> <li>• Place jumper across cad cell terminals after burner motor turns on.</li> </ul>	Indicator light is on.	Replace cad cell bracket assembly.
	Indicator light is off.	Replace R7184.
NOTE: Restricted Mode - (Limited Reset): In order to limit the accumulation of unburned oil in the combustion chamber, the control can be reset only 3 times, after which, the control locks out. The reset count returns to zero each time a call for heat is successfully completed.  To reset from RESTRICTED MODE: press and hold the reset button for 30 seconds. When the LED flashes twice, the device has reset.		
NOTE: Disable function: Pressing and holding the reset button will disable all functions until the button is released. The will restart at the beginning of the normal heat cycle on SAFETY CHECK.		

**TABLE C-4: SYSTEM AND GENERAL TROUBLESHOOTING**

Problem	Possible Cause	Remedy
Furnace will not start.	Thermostat not calling for heat.	Check thermostat and adjust. Also, check thermostat for accuracy; if it is a mercury switch type, it might be off level.
	No power to furnace.	Check furnace switch, main electrical panel furnace fuse or circuit breaker. Also look for any other hand operated switch, such as an old poorly located furnace switch which was not removed during furnace replacement.
	Thermostat faulty.	Remove thermostat wires from oil primary control terminals T-T. Place a jumper across T-T. If furnace starts, replace thermostat, thermostat sub-base (if equipped), or both.
	Oil primary control faulty.	Check reset button on oil primary control. Remove thermostat wires from oil primary control terminals T1 - T2. Check for 24v across T -T. If no voltage is present, check for 115v to oil primary control. If 115v is present, go to Table C-3.
	Photo Cell wiring shorted or room light leaking into photo cell compartment	Check photo cell (cad cell) wiring for short circuits. Also, check for room light leaking into cad cell compartment. Repair light leak if necessary. See Table C-3.
	Open safety switch.	Check for open limit or auxiliary limit. Also, check internal wiring connections; loose connectors, etc.

*Continued on next page*

**TABLE C-4: SYSTEM & GENERAL TROUBLESHOOTING, continued from previous page**

<b>Problem</b>	<b>Possible Cause</b>	<b>Remedy</b>
Furnace will not start without first pushing oil primary control reset button.  (Happens on frequent basis)	No fuel oil.	Check fuel oil supply. Check that all hand operated fuel oil valves are in the open position. Fill oil storage tank if necessary.
	Clogged nozzle.	Replace nozzle with high quality replacement. Use rating plate or Tables in Appendix A as a guide.
	Clogged oil filter.	Replace oil tank filter or in-line filter if used.
	Low oil pump pressure.	Connect pressure gauge to oil pump. Adjust pump pressure, or replace oil pump if necessary. Ensure that erratic pressure readings are not caused by defective fuel oil line.
	Air getting into fuel oil lines, or fuel oil line dirty, clogged, or in some manner defective.	Check fuel oil lines. Replace any compression fittings found with high quality flared fittings. Check for any signs of oil leaks. Any oil leak is a potential source of air or contaminants.
	Defective burner motor.	Check burner motor. If burner motor is cutting out on over-load, determine why. Replace if necessary.
Furnace starts, but cuts out requiring manually resetting the oil protector reset button.	Photo Cell (Cad Cell) defective.	If cad cell is dirty, clean it. (Determine why cad cell is getting dirty). If cad cell is poorly aimed, realign it. NOTE: The photocell should have a resistance of 100K $\Omega$ in absence of light; a maximum of 1500 $\Omega$ in the presence of light. Ensure that room light is not leaking into the cad cell compartment. (see diagnostic light section).
Furnace starts, but cuts out requiring manually resetting the oil protector reset button.	No fuel oil.	Check fuel oil supply. Check that all hand operated fuel oil valves are in the open position. Fill oil storage tank if necessary.
	Clogged nozzle.	Replace nozzle with high quality replacement. Use rating plate or Tables in Appendix A as a guide.
	Clogged oil filter.	Replace oil tank filter or in-line filter if used.
	Low oil pump pressure.	Connect pressure gauge to oil pump. Adjust pump pressure, or replace oil pump if necessary. Ensure that erratic pressure readings are not caused by defective fuel oil line.
	Air getting into fuel oil lines, or fuel oil line dirty, clogged, or in some manner defective.	Check fuel oil lines. Replace any compression fittings found with high quality flared fittings. Check for any signs of oil leaks. Any oil leak is a potential source of air or contaminants.
	Defective burner motor.	Check burner motor. If burner motor is cutting out on over-load, determine why. Replace if necessary.
	Water or contaminants in oil.	Drain fuel oil storage tank, replace fuel oil. (Consult with fuel oil supplier).
	Frozen oil line.	Gently warm oil line. Insulate oil line. (Outdoor piping size may require increased diameter).

Continued on next page

**TABLE C-4: SYSTEM & GENERAL TROUBLESHOOTING**, *continued from previous page*

<b>Problem</b>	<b>Possible Cause</b>	<b>Remedy</b>
Oil burner sputtering at nozzle	Electrodes out of adjustment or defective.	Check electrode settings. check electrodes for dirt build-up or cracks in porcelain.
	Poor transformer high voltage connections or defective transformer.	Check contacts between the igniter and electrodes. If OK, replace the igniter
	Fuel oil filter clogged.	Replace fuel oil storage tank filter and / or fuel oil in-line filter.
	Defective oil pump.	Check burner motor / fuel oil pump coupling. Check oil pump pressure. Replace fuel oil pump if necessary.
	Fuel oil line partially clogged or contains air.	Bleed air from oil line. If problem persists, replace oil line.
Excessive fuel oil consumption.	System temperature rise too high.	System temperature rise ideally should not exceed 85°F. Check for clogged air filters. Check blower fan for excess dirt build-up or debris. Speed up blower fan if necessary.
	Poor "fan off" delay timing selection, (fan stops too soon).	Check "fan off" delay timing setting. Use a duct thermometer in the supply air plenum take-off or first few inches of the supply air trunk duct. Ideally, the fan will shut off at a temperature of 90° - 100°F. Manipulate the dip switch settings to come as close as possible to this "fan off" temperature.
	Fuel oil leak.	Check fuel oil line for leaks. Repair or replace if necessary.
	Stack temperature too high.	Check stack temperature. Stack temperatures will normally range from 350° to 450°F. Check draft regulator. Draft should be set to 0.02 in. w.c.
	Thermostat improperly adjusted or in poor location.	Check thermostat heat anticipator setting against measured amperage draw. Increase heat anticipator setting if necessary. If the thermostat is being influenced by drafts, sunlight, duct work, etc., relocate to more suitable location.
Too much smoke.	Insufficient combustion air adjustment at oil burner, or improper draft pressure.	Adjust the oil burner combustion air band and draft regulator to gain the highest practical CO <sub>2</sub> or lowest practical O <sub>2</sub> content in the flue gases. See Burner Set Up.
	Heat exchanger partially clogged.	Check for soot build-up in heat exchanger flue passages, especially in the outer radiator.
Soot building up on blast tube (end coning).	Poor alignment between oil burner blast tube and fire pot.	Check alignment. blast tube should be centered with fire pot burner opening. Oil burner head should be ¼ inch back from the inside surface of the fire pot.
	Flame impingement caused by Incorrect nozzle angle.	Check nozzle size and angle. (See Appendix A). Check distance from head to inside surface of the fire pot.
	Defective fire-pot	Check fire-pot. Repair or replace.

*Continued on next page*

**TABLE C-4: SYSTEM & GENERAL TROUBLESHOOTING, continued from previous page**

<b>Problem</b>	<b>Possible Cause</b>	<b>Remedy</b>
Furnace will not warm home to desired temperature.	Airflow blocked or dirty air filter.	Clean or replace air filter.
	Thermostat adjustments or location.	Check thermostat heat anticipator setting against measured amperage draw. Increase heat anticipator setting if necessary. If the thermostat is being influenced by drafts, sunlight, duct work, etc., relocate to more suitable location.
	Insufficient airflow.	Check all dampers. Open closed dampers including registers in unused rooms. Check system temperature rise. If temperature rise is too high, speed up blower fan.
	Defective high limit control.	Test high limit function of all limit switches. Use a duct thermometer to assess accuracy of limit control. Check for obstructions to airflow around limit switch bi-metal elements. Replace control if necessary.
	Under-sized nozzle.	Check nozzle. If problem is not caused by air flow problems, use larger nozzle, if permitted by rating plate.
	Blower fan motor stopping intermittently on overload.	Check blower fan motor amperage draw. Check motor ventilation ports, clean if necessary. Replace motor if necessary.
	Burner motor stopping intermittently on overload.	Check burner motor. Replace if necessary.
Home does not heat evenly	Improper distribution of heat.	This is not likely to be a furnace problem. Balance duct system.
Supply air temperature too hot.	Airflow blocked or dirty air filter.	Clean or replace air filter.
	Insufficient airflow.	Check all dampers. Open closed dampers including registers in unused rooms. Check system temperature rise. If temperature rise is too high, speed up blower fan.
Supply air temperature too cool.	Excess airflow.	Check system temperature rise. Slow down blower fan if necessary.
	Excessive duct losses.	Check supply air ductwork. Seal leaky joints and seams. Insulate ductwork if necessary.
Supply air temperature too cool during first moments of furnace cycle.	Fan control "fan on" setting too low.	Increase differential between fan control "fan off" and "fan on" settings. (L4064B, L6064A fan / limit controls only, no adjustments available for L4064W fan / limit control). Register air deflectors may help.
	Excessive duct losses.	Check supply air ductwork. Seal leaky joints and seams. Insulate ductwork if necessary.

**HOME OWNER'S REFERENCE TABLE:**

**Installation Contractor:**

Model No.	
Serial No.	
Date Installed	
Contractor	
Contact	
Address	
Postal Code	
Telephone No.	
After Hours No.	

**Service Contractor if different from Installation Contractor:**

Service Tech.	
Telephone No.	
After Hours No.	

**Fuel Supplier:**

Oil Supplier	
Contact	
Telephone No.	
After Hours No.	

**Oneida Royal Division**  
2201 Dwyer Avenue, Utica, NY 13504-4729  
315-797-1310  
[www.uticaboilers.com](http://www.uticaboilers.com)





## Free Manuals Download Website

<http://myh66.com>

<http://usermanuals.us>

<http://www.somanuals.com>

<http://www.4manuals.cc>

<http://www.manual-lib.com>

<http://www.404manual.com>

<http://www.luxmanual.com>

<http://aubethermostatmanual.com>

Golf course search by state

<http://golfingnear.com>

Email search by domain

<http://emailbydomain.com>

Auto manuals search

<http://auto.somanuals.com>

TV manuals search

<http://tv.somanuals.com>