



OWNER'S OPERATING MANUAL



VX-4000d **VX-5000d**

**Digital Light Processing™ Projector
and DHD™ Controller**

Software Version 2.00



THE WORLD'S FINEST HOME THEATER PRODUCTS™

TWO YEAR LIMITED WARRANTY

For Projectors, Video Processors and Controllers

Congratulations on your purchase of a Runco video product and welcome to the Runco family! We believe Runco produces "The World's Finest Home Theater Products." With proper installation, setup and care, you should enjoy many years of unparalleled video performance.

This is a LIMITED WARRANTY as defined in the Magnuson-Moss Warranty Act. Please read it carefully and retain it with your other important documents.

WHAT IS COVERED UNDER THE TERMS OF THIS LIMITED WARRANTY:

SERVICE LABOR: Runco will pay for service labor by a Runco Authorized Service Center when needed as a result of manufacturing defect for a period of two (2) years from the effective date of delivery to the end user (excluding the lamp).

PARTS (not including the lamp): Runco will provide new or rebuilt replacement parts for the parts that fail due to defects in materials or workmanship for a period of two (2) years from the effective date of delivery to the end user. Such replacement parts are then subsequently warranted for the remaining portion (if any) of the original warranty period.

PROJECTOR LAMP: Runco will pay for service labor by a Runco Authorized Service Center when needed as a result of a manufacturing defect for a period of six (6) months or 1000 hours, whichever comes first, from the effective date of delivery to the end user. In addition, Runco will provide a new or rebuilt replacement lamp for the lamp that fails due to defects in materials or workmanship for a period of six (6) months or 1000 hours, whichever comes first, from the effective date of delivery to the end user. Such replacement lamps are then subsequently warranted for the remaining portion (if any) of the original warranty period.

WHAT IS NOT COVERED UNDER THE TERMS OF THIS LIMITED WARRANTY:

This Limited Warranty only covers failure due to defects in materials and workmanship that occur during normal use and does not cover normal maintenance. This Limited Warranty does not cover cabinets or any appearance items; failure resulting from accident, misuse, abuse, neglect, mishandling, misapplication, faulty or improper installation or setup adjustments; improper maintenance, alteration, improper use of any input signal; damage due to lightning or power line surges, spikes and brownouts; damage that occurs during shipping or transit; or damage that is attributed to acts of God. In the case of remote control units, damage resulting from leaking, old, damaged or improper batteries is also excluded from coverage under this Limited Warranty.

CAUTION: THIS LIMITED WARRANTY ONLY COVERS RUNCO PRODUCTS PURCHASED FROM RUNCO AUTHORIZED DEALERS. ALL OTHER PRODUCTS ARE SPECIFICALLY EXCLUDED FROM COVERAGE UNDER THIS LIMITED WARRANTY. MOREOVER, DAMAGE RESULTING DIRECTLY OR INDIRECTLY FROM IMPROPER INSTALLATION OR SETUP IS SPECIFICALLY EXCLUDED FROM COVERAGE UNDER THIS LIMITED WARRANTY.

RIGHTS, LIMITS AND EXCLUSIONS:

Runco limits its obligations under any implied warranties under state laws to a period not to exceed the warranty period. There are no express warranties. Runco also excludes any obligation on its part for incidental or consequential damages related to the failure of this product to function properly. Some states do not allow limitations on how long an implied warranty lasts, and some states do not allow the exclusion or limitation of incidental or consequential damages. So the above limitations or exclusions may not apply to you. This warranty gives you specific legal rights, and you may also have other rights that vary from state to state.

EFFECTIVE WARRANTY DATE:

This warranty begins on the effective date of delivery to the end user. For your convenience, keep the original bill of sale as evidence of the purchase date.

IMPORTANT -- WARRANTY REGISTRATION:

Please fill out and mail your warranty registration card. It is imperative that Runco knows how to reach you promptly if we should discover a safety problem or product update for which you must be notified.

CONTACT A RUNCO AUTHORIZED SERVICE CENTER TO OBTAIN SERVICE:

Repairs made under the terms of this Limited Warranty covering your Runco video product will be performed at the location of the product, during usual working hours, providing location of product is within normal operating distance from a Runco Authorized Service Center. In some instances it may be necessary for the product to be returned to the Runco factory for repairs. If, solely in Runco's judgment, location of product to be repaired is beyond normal operating distance of the closest Runco Authorized Service Center, or the repair requires the unit be returned to the Runco factory, it is the owner's responsibility to arrange for shipment of the product for repair. These arrangements must be made through the selling Runco Dealer. If this is not possible, contact Runco directly for a Return Authorization number and shipping instructions. Runco will return product transportation prepaid in the United States, unless no product defect is discovered. In that instance, shipping costs will be the responsibility of the owner.

COPYRIGHT AND TRADEMARKS:

© Copyright 2006 Runco International. This document contains proprietary information protected by copyright, trademark and other intellectual property laws. All rights are reserved. No part of this manual may be reproduced by any mechanical, electronic or other means, in any form, without prior written permission of the manufacturer.

Reflection, Enhanced GEN3, DHD, Vivix, Virtual Cinema, CineWide, AutoScope, O-Path, CinOptx, LiveLink, CSMS, SuperOnyx and VirtualWide are trademarks of Runco International. All other trademarks and registered trademarks used in this document are the property of their respective owners.

Runco International products are manufactured under one or more of the following patents: US. Patent 6755540 and Other Patents Pending.

ADDITIONAL INFORMATION:

To locate the name and address of the nearest Runco Authorized Service Center, or for additional information about this Limited Warranty, please call or write:

RUNCO INTERNATIONAL, INC.
Attn: Customer Service Department
2900 Faber Street
Union City, CA 94587
Ph: (510) 324-7777
Fax: (510) 324-9300
Toll Free: (800) 23-RUNCO

RUNCO VIDEO-PRODUCT INFORMATION
RETAIN THIS INFORMATION FOR YOUR RECORDS

Model Purchased _____ Date _____

Serial Number _____

Runco Authorized Dealer Name _____

Address _____

City _____ State/Province _____ Postal Code _____

Phone _____ Fax _____

Safety Precautions

Thank you for your purchase of this quality Runco video projector! It has been designed to provide you with the quality of video that is expected in a home theater. For the best performance, please read this manual carefully as it is your guide through the menus and operation.

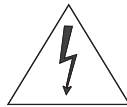
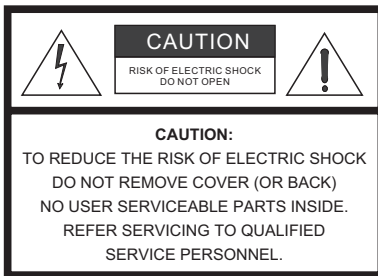

WARNING

This symbol is intended to alert the user to the presence of uninsulated “dangerous voltage” within the product’s enclosure that may be of sufficient magnitude to constitute a risk of electric shock.



This symbol is intended to alert the user to the presence of important operating and maintenance (servicing) instructions in the literature accompanying the appliance.

This equipment has been tested and found to comply with the limits for a Class B digital device, pursuant to Part 15 of the FCC Rules. These limits are designed to provide reasonable protection against harmful interference in a residential installation.

1. Read these instructions.
2. Keep these instructions.
3. Heed all warnings.
4. Do not use this equipment near water, outdoors or otherwise exposed to the elements.
5. Clean only with a dry cloth.
6. Do not block any ventilation openings.
7. Do not install near any heat sources such as radiators, heat registers, stoves, or other apparatus (including amplifiers) that produce heat.
8. Do not defeat the safety feature of the polarized or grounding type plug. A polarized type plug has two blades with one wider than the other. A grounding type plug has two blades and a third grounding prong. The third prong is provided for your safety. If the provided plug does not fit into your outlet, consult an electrician for the replacement of the obsolete outlet.
9. The 12V trigger only outputs DC 12V signal for triggering. Do not connect to any other power input or output. This could cause damage to this unit.
10. Only use accessories specified by Runco International.
11. Keep the packing material in case the equipment should ever need to be shipped.
12. Unplug this projector during lightning storms or when it will not be used for an extended period of time.
13. The lamp becomes extremely hot during operation. Allow the projector to cool down for approximately 45 minutes prior to removing the lamp assembly for replacement. Do not operate lamps beyond the rated lamp life. Excessive operation of lamps beyond rated life could cause them to explode in rare occasions.
14. Refer all servicing to qualified service personnel. Servicing is required when the projector has been damaged in any way, objects have fallen or spilled into the projector, the projector has been exposed to rain or moisture, does not operate normally, or has been dropped.

Table of Contents

TWO YEAR LIMITED WARRANTY	iii
Safety Precautions	vi
1. Introduction	1
About This Manual	1
Target Audience	1
If You Have Comments About This Manual.....	1
Textual and Graphic Conventions	1
Using This Manual	2
Description, Features and Benefits	3
Key Features and Benefits	3
Parts List	4
2. Controls and Functions	5
VX-4000d/VX-5000d at a Glance	5
VX-4000d/VX-5000d Rear Panel	8
DHD Controller Front Panel	9
DHD Controller Rear Panel	11
Outputs	11
Inputs	11
VX-4000d/VX-5000d Remote Control Units	13
Standard DHD Remote Control.....	13
Touch-Screen Remote.....	16
3. Installation	19
Remote Control	19
Battery Installation	19
Notes on Remote Control Operation.....	19
Quick Setup	21
Installation Considerations	22
Installation Type.....	22
Ambient Light	22
Throw Distance.....	23
Vertical and Horizontal Position.....	25
Vertical and Horizontal Lens Shift.....	25

Folded Optics	27
Other Considerations	27
Installing the Optional CineWide Lens	27
Mounting the VX-4000d/VX-5000d	28
Floor Mounting.....	28
Ceiling Mounting	28
Adjusting the Projection Angle	28
Connections to the VX-4000d/VX-5000d and DHD Controller	28
Connector Panel Access.....	28
Connecting the DHD Controller to the VX-4000d/VX-5000d	28
Connecting Source Components to the DHD Controller	30
RS-232 Controller Connection	34
Connecting 12-Volt Trigger Outputs to External Theater Components	34
Connecting to AC Power	35
4. Operation	37
Turning on the Power	37
Adjusting the Picture Orientation	37
Selecting the Input Source	37
Lens Adjustments	38
Focus	38
Zoom.....	38
Vertical and Horizontal Lens Shift.....	38
Using the On-Screen Menus	39
Main Menu.....	41
Input Source.....	41
Aspect Ratio	41
Picture	43
Input Position.....	47
ISF Presets	48
Information	48
Calibration	49
Service	51
5. Maintenance and Troubleshooting	55
Lamp Replacement	55
Lens Replacement	56
Troubleshooting Tips	58

6. Serial Communications	61
RS-232 Connection and Port Configuration	61
Serial Command Syntax	61
7. Specifications	67
VX-4000d/VX-5000d Specifications	67
DHD Controller Specifications	69
VX-4000d/VX-5000d Dimensions	70

Notes:

List of Figures

2-1. VX-4000d Front/Top/Side/Bottom View	5
2-2. VX-5000d Front/Top/Side/Bottom View	6
2-3. VX-4000d/VX-5000d Rear Panel	8
2-4. DHD Controller Front Panel	9
2-5. DHD Controller Rear Panel	11
2-6. Standard DHD Remote Control	13
2-7. Touch-Screen Remote Control.....	16
3-1. Available Range of the Remote Control	19
3-2. Estimating Throw Distance	23
3-3. Projector Placement	25
3-4. Vertical Lens Shift.....	25
3-5. Horizontal Lens Shift.....	26
3-6. Folded Optics.....	27
3-7. Connecting the VX-4000d/VX-5000d to the DHD Controller	29
3-8. DVI Source Connections	30
3-9. Digital (DTV) RGB or Component Video Connections	31
3-10. Analog RGB Connections.....	32
3-11. Composite, S-Video and Component Video Connections.....	33
3-12. RS-232 Control System Connection.....	34
3-13. Connecting 12-Volt Trigger Outputs	34
4-1. Vertical and Horizontal Lens Shift Adjustments	38
4-2. DHD Controller OSD Menu Structure for VX-4000d/VX-5000d	40
4-3. Typical PLUGE Pattern for Adjusting Brightness	44
4-4. Typical Gray Bar Pattern for Adjusting Contrast	45
4-5. Typical Color Bar Pattern for Adjusting Color Saturation and Tint.....	45
4-6. Typical Test Pattern for Adjusting Sharpness	47
4-7. Keystone Correction.....	52
5-1. VX-5000d Lens Assembly Exploded View	56
7-1. VX-4000d/VX-5000d Dimensions	70

Notes:

1. Introduction

This Owner's Manual describes how to install, set up and operate the Runco VX-4000d/VX-5000d DLP Projector and DHD Controller. It describes the features and functions available with DHD Controller Software version 2.0 and later.

Throughout this manual, the Runco VX-4000d/VX-5000d DLP Projector and DHD Controller are referred to collectively as the "VX-4000d/VX-5000d." The information in this manual applies to both the VX-4000d and VX-5000d, except where otherwise indicated.

Runco has prepared this manual to help home theater installers and end users get the most out of the VX-4000d/VX-5000d.

Runco has made every effort to ensure that this manual is accurate as of the date it was printed. However, because of ongoing product improvements and customer feedback, it may require updating from time to time. You can always find the latest version of this and other Runco product manuals on-line, at www.runco.com.

Runco welcomes your comments about this manual. Send them to techpub@runco.com.

Text Conventions: The following conventions are used in this manual, in order to clarify the information and instructions provided:

- Remote and built-in keypad button identifiers are set in upper-case bold type; for example, "Press **EXIT** to return to the previous menu."
- All keys with functional names are initial-capped, set in bold type and enclosed in angle brackets. These keys are the following: **<Enter>**, **<Spacebar>**, **<Control>**, **<Esc>** and **<Tab>**.
- **<Enter>** indicates that you may press either the RETURN or ENTER key on your keyboard if it has both keys.
- Computer input (commands you type) and output (responses that appear on-screen) is shown in monospace (fixed-width) type; for example: "To change the aspect ratio to Letterbox, type LETTERBOX **<Enter>**."

In addition to these conventions, underlining, boldface and/or italics are occasionally used to highlight important information, as in this example:



Note

*A carriage return **must** be used after each command or string.*

1.1 About This Manual

◀ Target Audience

◀ If You Have Comments About This Manual...

◀ Textual and Graphic Conventions

Graphic Conventions: These symbols appear in numerous places throughout the manual, to emphasize points that you must keep in mind to avoid problems with your equipment or injury:



Tip

TIPS highlight time-saving short cuts and helpful guidelines for using certain features.



Note

NOTES emphasize text with unusual importance or special significance. They also provide supplemental information.



Caution

CAUTIONS alert users that a given action or omitted action can degrade performance or cause a malfunction.



WARNING

WARNINGS appear when a given action or omitted action can result in damage to the equipment, or possible non-fatal injury to the user.



DANGER!

DANGER appears when a given action can cause severe injury or death.

1.2 Using This Manual

Use the following table to locate the specific information you need in this manual.

If you need...	... Turn to page:
Information about obtaining service	iv
General information about the VX-4000d/VX-5000d DLP Projector and DHD Controller	3
Installation instructions	19
First-time configuration instructions	37
Advanced configuration instructions	49
Troubleshooting tips	58
Product specifications	67

The Reflection™ VX-4000d and VX-5000d incorporate Runco's exclusive Enhanced GEN 3™ engineering advancements to make more efficient use of optical light engine design. This results in greater light output and dramatically increases contrast ratio.

Among the advances Runco has developed are a sophisticated color balancing system and Reflectance Volume Regulation™ (RVR™), which provides the perfect balance of black and white levels.

These engineering achievements are combined with lens choices featuring world-class optics and lens shift versatility. The resulting images are superb. In fact, the VX-5000d can easily surpass the black levels of film projectors!

Included with the VX-4000d/VX-5000d is Runco's Digital High Definition (DHD™) Controller, featuring advanced Vivix II™ video processing, superb scaling and aspect ratio control. Runco's exclusive LiveLink™ DVI cable system circuitry is integrated into the projector to preserve HD signal quality over long runs.

The VX-4000d produces an impressive 1600 ANSI lumens of light output (CSMS™ light output of 16.9 to 29.2 ft-Lamberts). The VX-5000d produces 1700 ANSI lumens of light output (CSMS light output of 17.2 to 29.7 ft-Lamberts).

This advanced design provides pure digital connections from input to light engine for absolutely stellar pictures. In addition, Runco's multiple aspect ratio control includes its unique VirtualWide™ mode for viewing standard video formats in widescreen without loss of image quality.

For uncompromising widescreen reproduction of movies originally filmed in the "scope" (2.35:1) format, the VX-4000d/VX-5000d can be equipped with Runco's patent-pending CineWide™ technology, a combination of software, electronics and high-quality anamorphic optics. CineWide maintains constant vertical height on the screen just as in a movie theater. When a viewer transitions from 1.78:1 (16:9) program material to 2.35:1, the image simply gets wider while full height is maintained. Also available with the VX-4000d/VX-5000d is CineWide with AutoScope™, an enhanced, remote-controlled motorized version of CineWide.

Discrete IR and RS-232 control make custom installation seamless, while discrete source and aspect ratio selection accommodate any automation control system.

The VX-4000d/VX-5000d offers these key features and benefits:

- Runco-engineered, Enhanced GEN 3 Technology™ with RVR
- Native Resolution: 1280 x 720 (16:9 Native Aspect Ratio)
- Two DVI Inputs with High-bandwidth Digital Content Protection (HDCP)
- HDTV Compatible
- CinOptx™ *Proteus* (VX-4000d) or *Telesto* (VX-5000d) lens options for stunning sharpness and throw distance flexibility

1.3 Description, Features and Benefits

◀ Key Features and Benefits

Parts List ➤ Your VX-4000d/VX-5000d is shipped with the following items. If any items are missing or damaged, please contact your Runco dealer or Runco Customer Service at (800) 23-RUNCO.

- VX-4000d/VX-5000d DLP Projector and DHD Controller
- Touch-Screen Remote Control Unit and three (3), AA-size batteries
- DHD Controller Remote Control Unit and two (2), AAA-size batteries
- AC Power Cords (2)
- RJ-11 Telephone Cable, 50 feet (15.24 meters)
- Serial Port Adapter, RJ-11 Female to DB-9 Female
- Rack-mount hardware for the DHD Controller
- Warranty information and registration card
- Runco VX-4000d/VX-5000d Owner's Operating Manual (this document)

Optional Accessories:

- CineWide™ technology (fixed, secondary anamorphic lens)
- CineWide™ with AutoScope™ system (secondary anamorphic lens and motorized mount)
- Ceiling mount kit
- DVI extension cables, available in lengths up to 20 meters (65.6 feet)

2. Controls and Functions

Figure 2-1 and Figure 2-2 show the key VX-4000d/VX-5000d components.

2.1 VX-4000d/VX-5000d at a Glance

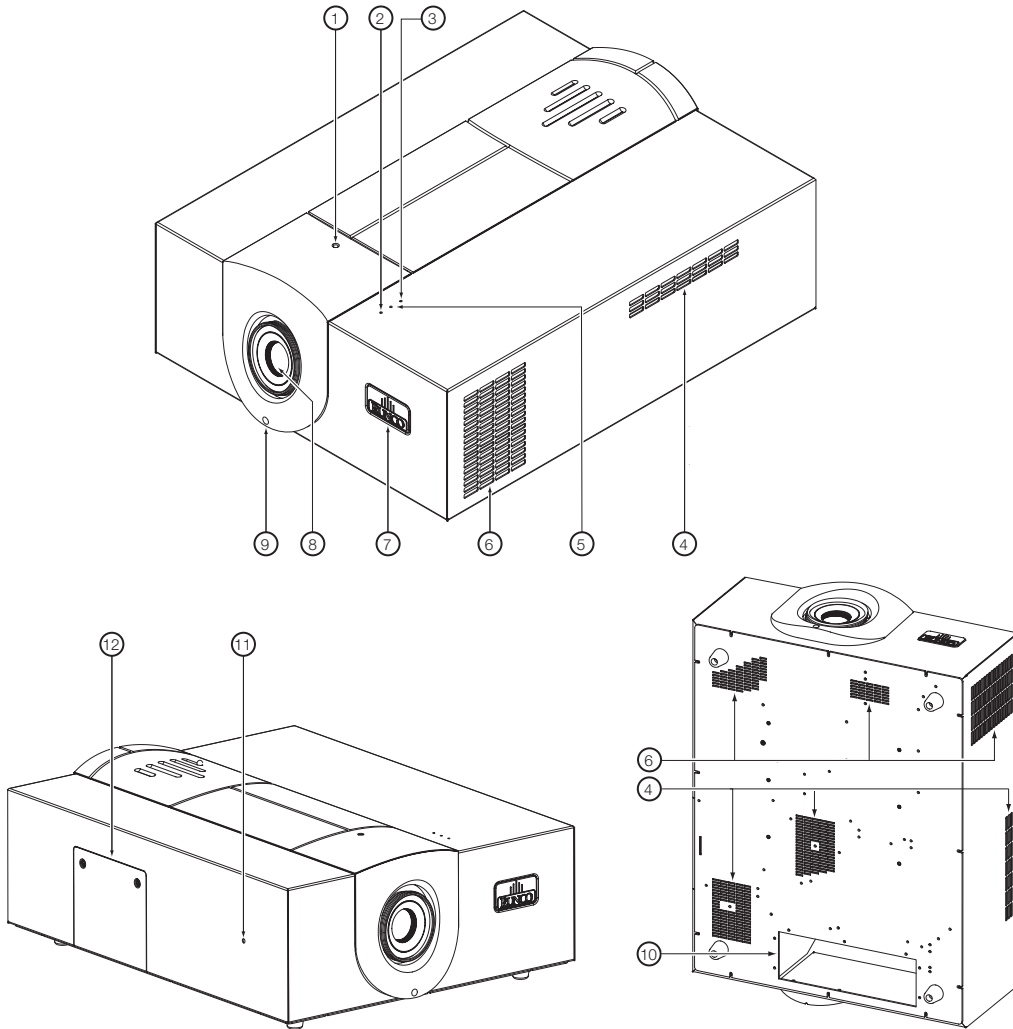

Figure 2-1. VX-4000d Front/Top/Side/Bottom View

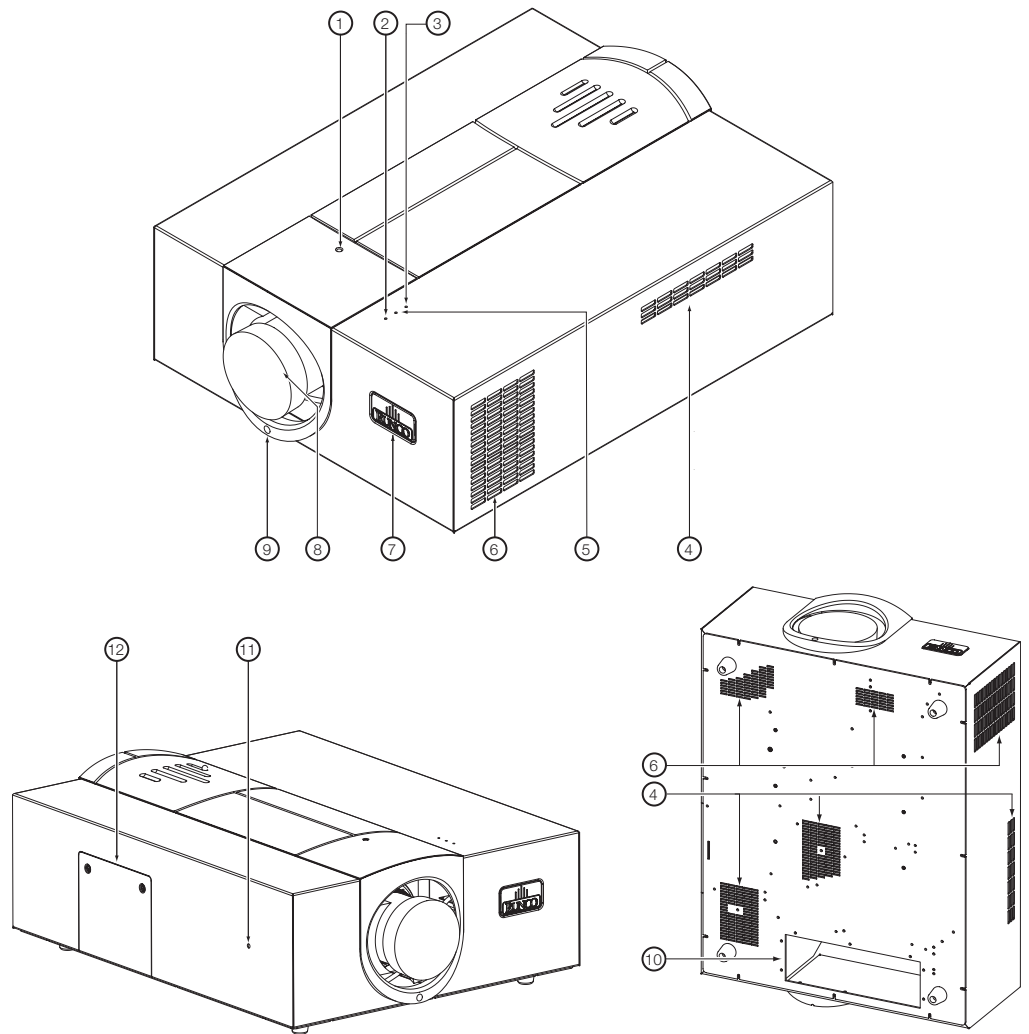

Figure 2-2. VX-5000d Front/Top/Side/Bottom View

-
1. **VERTICAL LENS SHIFT**
Using a 3/16" hex wrench, turn this to move the lens up or down.
 2. **POWER LED**
Lights red to indicate that the projector is in standby; lights blue to indicate normal operation.
 3. **TEMP LED**
Lights red to indicate that the projector has overheated and shut down.
 4. **INTAKE VENTS**
Cool air enters the projector through these vents. To prevent overheating, ensure that these vents are never blocked.
 5. **LAMP LED**
Lights blue to indicate normal lamp operation; off when the lamp has failed or the projector is off.
 6. **EXHAUST VENTS**
Hot air exits the projector through these vents. This air can be quite hot. Ensure that there are no heat-sensitive objects near it and that it is never blocked.
 7. **RUNCO LOGO / LENS CONTROL INFRARED (IR) RECEIVER**
During initial installation, rotate the logo plate one quarter-turn (90 degrees) to uncover the lens control IR receiver. This enables you to use the motorized focus and zoom (image size) controls.

When you have finished adjusting the zoom and focus, you can rotate the logo to match the projector orientation: inverted (ceiling-mounted) or upright. To rotate the logo, grip it at the sides, pull it away from the projector and turn it.
 8. **LENS**
 9. **LENS COVER SCREW**
Loosen this screw to remove the front jewelry, should you ever need to replace the lens.
 10. **CABLE OPENING**
Pass cables through this opening.
 11. **HORIZONTAL LENS SHIFT**
Using a 3/16" hex wrench, turn this to move the lens left or right.
 12. **LAMP COVER**
Remove this cover to access the lamp compartment.

2.2 VX-4000d/VX-5000d Rear Panel

Figure 2-3 shows the VX-4000d/VX-5000d rear panel.

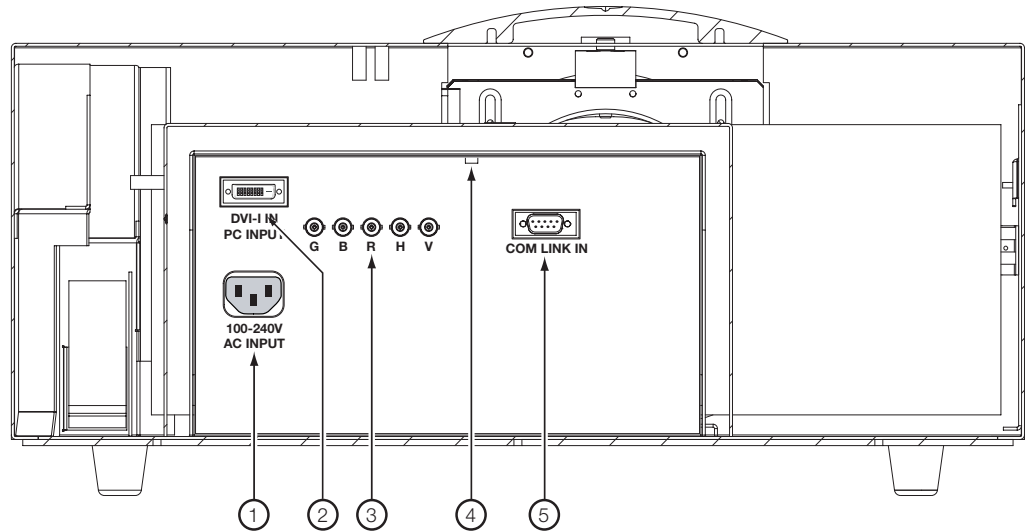

Figure 2-3. VX-4000d/VX-5000d Rear Panel

1. **POWER INPUT (100 to 240 VAC)**
Connect the VX-4000d/VX-5000d to power here.
2. **DVI-I INPUT**
An HDCP-compliant digital video input for connecting the DVI output from the DHD Controller.
3. **RGBHV INPUT**
Five, BNC connectors for connecting the RGBHV output from the DHD Controller.
4. **SERVICE RESET SWITCH**
For use by authorized service technicians only.
5. **ComLink INPUT (DB-9 male connector)**
Connect the ComLink (RS-232) output from the DHD Controller here, using the provided RJ11-to-DB9 adapter and communication cable.

Figure 2-4 shows the controls and indicators on the DHD Controller front panel; the paragraphs that follow describe them.

2.3 DHD Controller Front Panel

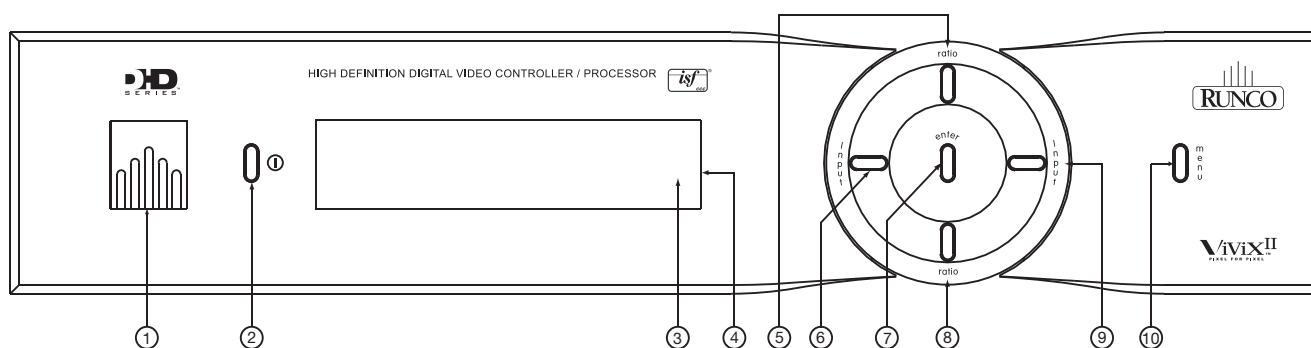

Figure 2-4. DHD Controller Front Panel

1. **RUNCO ICON**

Lights red to indicate that the DHD Controller is in standby mode; lights blue to indicate that the unit is on.

2. **POWER BUTTON**

Press once to toggle from standby mode to on mode. Press it again to return to standby mode. For a discrete on or off command, you can use the direct access buttons on the remote control.

3. **IR SENSOR**

Receives IR commands from the remote.

4. **VACUUM FLUORESCENT DISPLAY**

Can be used instead of the On-Screen Display (OSD). Displays currently-selected menu or -- if no menu is selected -- the current source, signal format (NTSC or PAL), input resolution and aspect ratio.

5. **UP BUTTON**

Used to direct select aspect ratios or move the menu cursor up in the On-Screen Display. When no menus are present on-screen, the **UP** button toggles you through aspect ratios in the following order:

Anamorphic - Standard (4:3) - Letterbox - VirtualWide - Cinema - Virtualwide 2.35

(Virtualwide 2.35 is available only on CineWide-equipped projectors. For more information about aspect ratios, refer to Table 4-1.)

6. **LEFT BUTTON**

Used to direct select inputs or move the menu cursor left in the On-Screen Display.

When no menu is present on-screen, the **LEFT** button toggles you through the different sources, in this order:

HD Pass Thru 2 - HD Pass Thru 1 - DVI 2 - DVI 1 - HD/RGB 2 - HD/RGB1 - Component SD - S-Video 2 - S-Video 1 - Composite

7. **ENTER BUTTON**

Press **ENTER** to select a highlighted menu item.

8. **DOWN BUTTON**

Used to direct select aspect ratios or move the menu cursor down in the On-Screen Display. When no menu is present on-screen, this button toggles you through the different aspect ratios, in this order:

Virtualwide 2.35 - Cinema - VirtualWide - Letterbox - Standard (4:3) - Anamorphic

9. **RIGHT BUTTON**

Used to direct select inputs or move the menu cursor right in the On-Screen Display. When no menus are present on-screen, the **RIGHT** button toggles you through the different sources, in this order:

Composite - S-Video 1 - S-Video 2 - Component SD - HD/RGB 1 - HD/RGB 2 - DVI 1 - DVI 2 - HD Pass Thru 1 - HD Pass Thru 2

10. **MENU BUTTON**

Press this button to access the OSD controls, or to exit the current menu and return to the previous one.

Figure 2-5 shows the rear connector panel on the DHD Controller.

2.4 DHD Controller Rear Panel

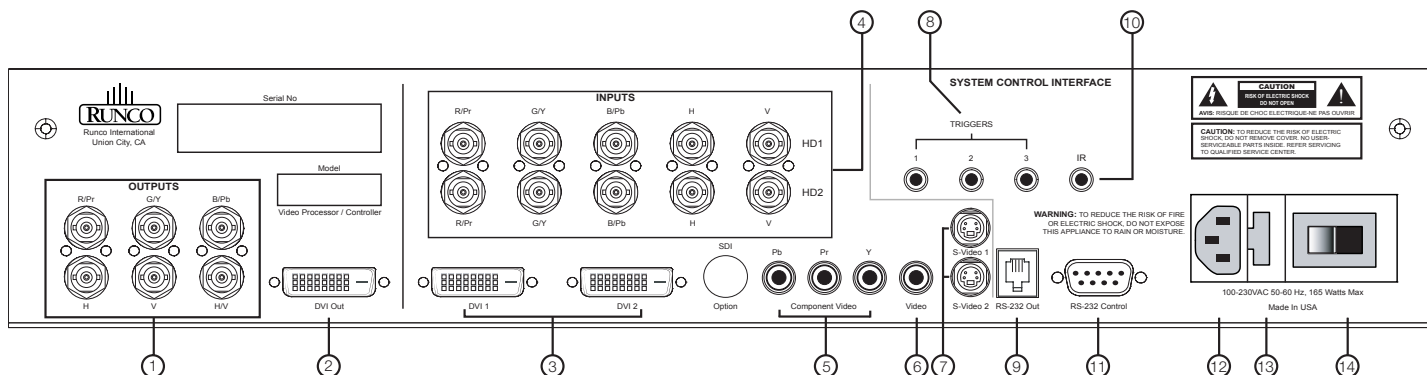

Figure 2-5. DHD Controller Rear Panel

1. ANALOG OUTPUTS (RGBHV)

Connect these to the RGBHV inputs on the VX-4000d/VX-5000d.

← Outputs



Note

If the DVI 1 or DVI 2 input is active and the input signal is HDCP-encrypted, the RGBHV output of the DHD Controller is disabled.

2. DVI OUT

Connect this to the DVI-I Input on the VX-4000d/VX-5000d.

3. DVI 1 / DVI 2 (Digital)

Two, HDCP-compliant digital video inputs for connecting a DVD player or HD tuner with a DVI or HDMI output.

4. HD1 / HD2 (Analog BNC connectors)

Five, BNC connectors for connecting either RGB or component high-definition television signals. The VX-4000d/VX-5000d automatically detects the signal format: RGB(HV) or YPrPb, 480p, 720p, 480i, 576i or 1080i.

5. COMPONENT VIDEO (RCA connectors)

Standard Definition (480i/576i) Component (YPrPb) input. This is the input for component video from sources such as DVD players.

← Inputs



Tip

For best results, do not run your DVD player in progressive mode.

6. **COMPOSITE VIDEO INPUT**

Standard composite video input for connecting a VCR, laser disc player or other composite video source.

7. **S-VIDEO 1 / S-VIDEO 2**

Two, standard S-Video inputs for connecting a DVD player, satellite receiver or Super VHS (S-VHS) VCR.

8. **12-VOLT (750 mA) TRIGGER OUTPUTS**

Connection for up to three (3), 12-volt trigger-controlled devices. These can be retractable screens, screen masks or the Runco CineWide with AutoScope system.

9. **ComLink (RS-232) OUTPUT**

Connect this to the ComLink (RS-232) input on the projector, using the provided RJ11-to-DB9 adapter and communication cable.

10. **IR**

Wired input from an external remote control or infrared receiver. It is a 3.5-mm, mini phono jack, wired as follows:

Ring = +5V

Tip = IR Input

Sleeve = Ground



Note

When an external remote control or infrared receiver is connected to the wired IR input, the IR sensor on the front of the DHD is disabled.

11. **RS-232 CONTROL PORT**

A female, 9-pin D-sub connector for interfacing with a PC or home theater automation/control system.

12. **POWER INPUT (100 to 240 VAC)**

Connect the DHD Controller to power here.

13. **MAIN AC FUSE**

This is the main AC input fuse (5mm x 20mm, 500 mA, 250V slow-blow).

14. **MAIN POWER SWITCH**

Disconnects or applies power to the DHD Controller.

The VX-4000d/VX-5000d ships with two remote control units:

- A standard Runco DHD Controller remote control unit; and
- A universal, touch-screen remote control unit that can be used with other home theater equipment.

Only the touch-screen remote control can be used to perform zoom and focus adjustments. For this reason, you must use it to complete the initial VX-4000d/VX-5000d installation and setup. After the projector has been installed, either remote control unit can be used; both provide similar functionality.

Figure 2-6 shows the standard DHD remote control, and the paragraphs that follow describe its functionality.

2.5 VX-4000d/VX-5000d Remote Control Units

◀ Standard DHD Remote Control

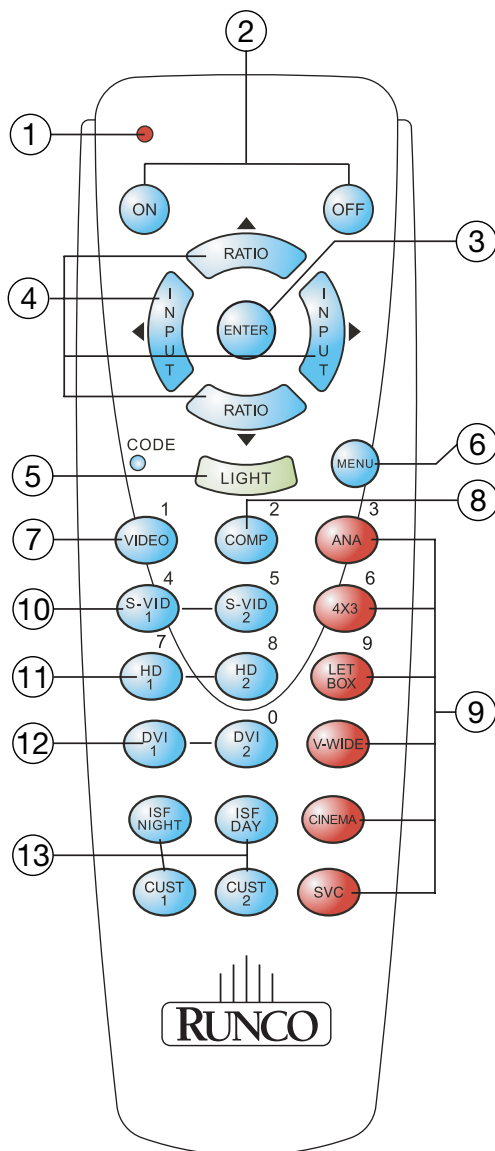

Figure 2-6. Standard DHD Remote Control

1. **IR OUTPUT INDICATOR**
Lights when a button is pressed to indicate that an IR signal is being transmitted.
2. **ON / OFF**
Press to turn the projector on or off.
3. **ENTER**
Press to select a highlighted menu item or confirm a changed setting.
4. **Cursor Buttons (▲, ◀, ▼, ▶)**
Use these buttons to select items or settings, adjust settings or switch display patterns.

When no menus are present on-screen, the **UP** and **DOWN** buttons toggle through the available aspect ratios, in this order:

UP Button = Anamorphic - Standard (4:3) - Letterbox - VirtualWide - Cinema - Virtualwide 2.35

DOWN Button = Virtualwide 2.35 - Cinema - VirtualWide - Letterbox - Standard (4:3) - Anamorphic



Note

*Virtualwide 2.35 is available only on CineWide-equipped projectors.
For more information about aspect ratios, refer to Table 4-1.*

Likewise, the **LEFT** and **RIGHT** buttons toggle through the different source inputs, in this order:

LEFT Button = HD Pass Thru 2 - HD Pass Thru 1 - DVI 2 - DVI 1 - HD/RGB2 - HD/RGB 1 - Component SD - S-Video 2 - S-Video 1 - Composite

RIGHT Button = Composite - S-Video 1 - S-Video 2 - Component SD - HD/RGB 1 - HD/RGB 2 - DVI 1 - DVI 2 - HD Pass Thru 1 - HD Pass Thru 2

5. **LIGHT**
Press to illuminate the buttons. (Not available on all models.)
6. **MENU**
Press this button to access the OSD controls, or to exit the current menu and return to the previous one.
7. **VIDEO (1)**
Press to select Composite video input as the source or to enter the numeric character "1."
8. **COMP (Component) (2)**
Press to select Component SD (480i/576i) video input as the source or to enter the numeric character "2."

9. Aspect Ratio Selection Buttons

Use the red buttons to select an aspect ratio directly or to enter numeric characters, as follows:

ANA (Anamorphic) (3)

For viewing 16:9 DVDs or HDTV programs in their native aspect ratio.

4X3 (Standard 4:3) (6)

Scales the input signal to fit 4:3 display mode in the center of the screen.

LETBOX (Letterbox) (9)

For viewing LaserDisc movies or non-anamorphic DVDs on a 4:3 screen.

V-WIDE (VirtualWide)

Enlarges a 4:3 image horizontally in a NON-linear fashion to fit 16:9 full screen display.

CINEMA

For viewing 2.35:1 source material on a 1.78:1 (16:9) screen. The upper and lower portions are masked.

SVC (CineWide-equipped projectors only)

Selects the VirtualWide 2.35 aspect ratio, which anamorphically compresses a 2.35:1 image to fill a 16:9 image area. The anamorphic lens then "stretches" the image back to 2.35:1.

10. S-VID 1 (4) / S-VID 2 (5) (S-Video)

Press to select an S-Video input or to enter the numeric character "4" or "5."

11. HD 1 (7) / HD 2 (8)

Press to select a HD (RGBHV or YPbPr component) input or to enter the numeric character "7" or "8."

12. DVI 1 / DVI 2 (0)

Press to select a Digital Video input. Press **DVI2** to enter the numeric character "0."

13. Memory Preset Buttons:

ISF NT (Night)

Press to recall settings for the current input from the "ISF Night" memory preset.

ISF DAY

Press to recall settings for the current input from the "ISF Day" memory preset.

CUST 1

Press to recall settings for the current input from the "Custom 1" memory preset.

CUST 2

Press to recall settings for the current input from the "Custom 2" memory preset.

Touch-Screen Remote ➤

The touch-screen remote control unit furnished with the VX-4000d/VX-5000d provides basically the same functionality as the standard Runco DHD remote. In addition, it gives you access to the motorized lens controls (focus and zoom) and can be programmed to control other, non-Runco home theater components. (For detailed programming instructions, refer to the manual provided with the remote control.)

Figure 2-7 shows the touch-screen remote control, and the paragraphs that follow describe its functionality.

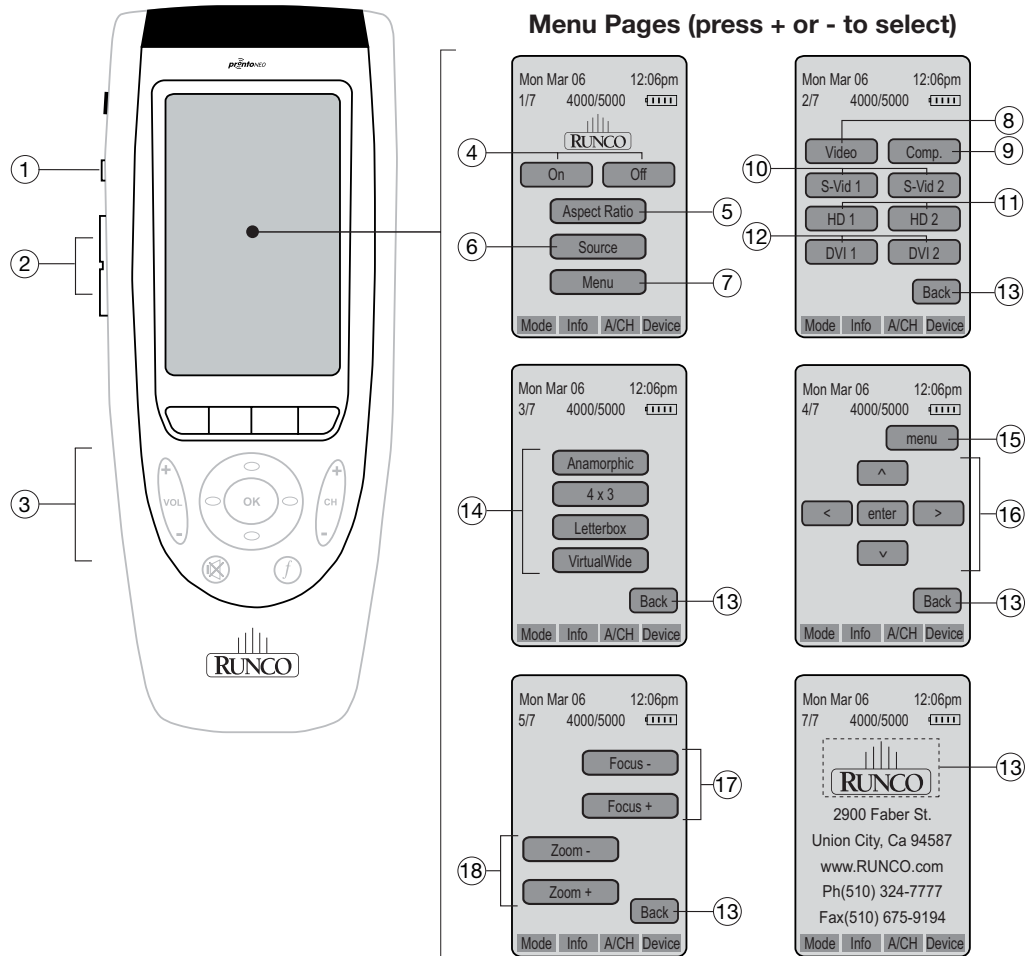

Figure 2-7. Touch-Screen Remote Control

1. **LIGHT**
Press to illuminate the buttons.
2. **+ / -**
Use these buttons to scroll through the six menu pages.
3. **VOLUME (+/-) / MUTE / OK / CH (+/-) / ⏸**
The remote control touch screen goes off after a period of inactivity, to conserve battery power. Press any of these buttons and the touch screen reappears. These buttons are not programmed to control the DHD Controller or projector; however, you can program them to control other equipment. Refer to the manual for the remote control for more information.

-
4. **POWER ON/OFF**
Use these buttons to turn the VX-4000d/VX-5000d on or off.
 5. **ASPECT RATIO**
Press this button to go to the aspect ratio menu page (3/7).
 6. **SOURCE**
Press this button to go to the source selection menu page (2/7).
 7. **MENU**
Press this button to go to the DHD Controller OSD menu navigation page (4/7).
 8. **VIDEO**
Press this button to switch to the Composite Video input.
 9. **COMP.**
Press this button to switch to the Component Video input.
 10. **S-VID 1 / S-VID 2**
Press these buttons to switch to the S-Video 1 or S-Video 2 input.
 11. **HD 1 / HD 2**
Press these buttons to switch to the HD/RGB 1 or HD/RGB 2 (RGBHV or YPbPr component) input.
 12. **DVI 1 / DVI 2**
Press these buttons to switch to the DVI 1 or DVI 2 input.
 13. **BACK**
Press this button to return to the main menu page (1/7).
 14. **Aspect Ratio Selection Buttons**
Use these buttons to select an aspect ratio directly, as follows:

ANAMORPHIC
For viewing 16:9 DVDs or HDTV programs in their native aspect ratio.

4 x 3 (Standard 4:3)
Scales the input signal to fit 4:3 display mode in the center of the screen.

LETTERBOX
For viewing LaserDisc movies or non-anamorphic DVDs on a 4:3 screen.

VIRTUALWIDE
Enlarges a 4:3 image horizontally in a NON-linear fashion to fit 16:9 full screen display.
 15. **MENU**
Press this button to access the OSD controls, or to exit the current menu and return to the previous one.

16. **ENTER / Cursor Buttons (▲, ◀, ▼, ▶)**

Use these buttons to select items or settings, adjust settings or switch display patterns.

When no menus are present on-screen, the **UP** and **DOWN** buttons toggle through the available aspect ratios, in this order:

UP Button = Anamorphic - Standard (4:3) - Letterbox - VirtualWide - Cinema - Virtualwide 2.35

DOWN Button = Virtualwide 2.35 - Cinema - VirtualWide - Letterbox - Standard (4:3) - Anamorphic



Note

Virtualwide 2.35 is available only on CineWide-equipped projectors. For more information about aspect ratios, refer to Table 4-1.

Likewise, the **LEFT** and **RIGHT** buttons toggle through the different source inputs, in this order:

LEFT Button = HD Pass Thru 2 - HD Pass Thru 1 - DVI 2 - DVI 1 - HD/RGB 2 - HD/RGB 1 - Component SD - S-Video 2 - S-Video 1 - Composite

RIGHT Button = Composite - S-Video 1 - S-Video 2 - Component SD - HD/RGB 1 - HD/RGB 2 - DVI 1 - DVI 2 - HD Pass Thru 1 - HD Pass Thru 2

Press **ENTER** to select a highlighted menu item or confirm a changed setting.

17. **FOCUS - / FOCUS +**

Press and hold either of these buttons to focus the projected image.

18. **ZOOM - / ZOOM +**

Press and hold the **ZOOM +** button to enlarge the image. Press and hold the **ZOOM -** button to zoom out.



Note

To use the motorized lens controls, first rotate the Runco logo plate one quarter-turn (90 degrees) to uncover the lens control IR receiver; see Figure 2-1 or Figure 2-2.

3. Installation

3.1 Remote Control

← Battery Installation

To install batteries in the remote control:

1. Remove the battery cover from the back of the remote control.
2. Insert the batteries included with the remote control. Ensure that the polarities correctly match the \oplus and \ominus markings inside the battery compartment.
3. Replace the battery cover.

Touch-Screen Remote



Standard DHD Remote

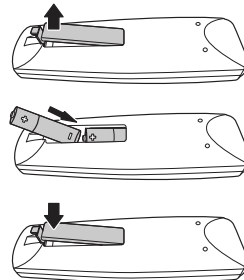

With the touch-screen

remote: After a few seconds, the remote starts up automatically and an Introduction screen appears. The remote control beeps twice to indicate that it has started up successfully.



Note

1. Do not mix an old battery with a new one or different types of batteries.
2. If you will not use the remote control for a long time, remove the batteries to avoid damage from battery leakage.

The remote control can be used to control the VX-4000d/VX-5000d within the ranges shown in Figure 3-1.

← Notes on Remote Control Operation

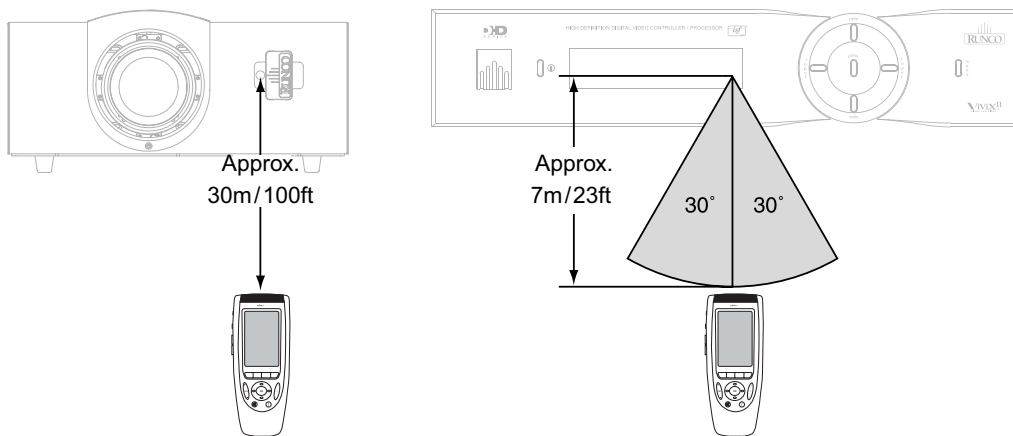

Figure 3-1. Available Range of the Remote Control

- Do not drop the remote control or expose it to moisture or high temperature.
- The remote control may malfunction under a fluorescent lamp. If that occurs, move the DHD Controller away from the fluorescent lamp.
- Make sure that there is nothing obstructing the infrared beam between the remote control and the IR receiver on the DHD Controller or projector.



Note

The signal from the remote control can be reflected by walls or other surfaces.

- If the effective range of the remote control decreases, or it stops working, replace the batteries with new ones.
- Ambient conditions may possibly impede the operation of the remote control. If this happens, point the remote control at the DHD Controller or projector and repeat the operation.

Table 3-1 gives a quick overview of the VX-4000d/VX-5000d installation process. The sections following this one provide detailed instructions.

3.2 Quick Setup



Note

Installation should be performed by a qualified custom video installation specialist.

Table 3-1. Installation Overview

Step	Procedure	For Details, Refer to page...
1	Choose a location for the projector	22
2	Install CineWide (secondary anamorphic) lens (optional)	27
3	Connect the DHD Controller to the projector	28
4	Connect signal sources to the DHD Controller	30
5	Connect external controller to RS-232 port (optional)	34
6	Connect other home theater components to 12-volt trigger outputs (optional)	34
7	Apply power to the projector	35, 37
8	For rear-screen and/or ceiling-mount installations, select the proper picture orientation	37
9	Lens adjustments: projected image size (zoom), position (shift) and focus	25, 38
10	Projector calibration: adjust the following for each input , starting with Component SD; save settings when finished: <ul style="list-style-type: none"> • Aspect ratio • Brightness • Contrast • Color level • Tint • Input position 	41 through 48

3.3 Installation Considerations

Proper installation of your projector will ensure the quality of your display. Whether you are installing a projector temporarily or permanently, you should take the following into account to ensure your projector performs optimally.

Installation Type ➤ Choose the installation type that best suits your needs: front or rear screen, floor mount or inverted mount. Table 3-2 compares these various installation methods.

Table 3-2. Projector Installation Options

Advantages	Considerations
Front Screen, Floor Mount Installation	
<ul style="list-style-type: none"> • Easy to set up • Can be moved or changed quickly • Easy to access 	<ul style="list-style-type: none"> • Shares floor space with audience
Front Screen, Inverted Mount (ceiling) Installation	
<ul style="list-style-type: none"> • Does not take up audience space • Projector is unobtrusive • Projector cannot be accidentally moved 	<ul style="list-style-type: none"> • Installation is more permanent • Projector access is more difficult
Rear Screen, Floor Mount Installation	
<ul style="list-style-type: none"> • Projector is completely hidden • Projector is easily accessed • Usually good ambient light rejection 	<ul style="list-style-type: none"> • Requires separate room • Installation cost is usually higher
Rear Screen, Inverted Mount (ceiling) Installation	
<ul style="list-style-type: none"> • Projector is completely hidden • Usually good ambient light rejection 	<ul style="list-style-type: none"> • Requires separate room • Installation cost is usually higher
Rear Screen, Floor Mount with Mirror	
<ul style="list-style-type: none"> • Projector is completely hidden • Usually good ambient light rejection • Requires less space behind screen than other rear screen installations 	<ul style="list-style-type: none"> • Requires separate room • Installation cost is usually higher

Ambient Light ➤ In general, minimize or eliminate light sources directed at the screen. Contrast ratio in your images will be noticeably reduced if light directly strikes the screen, such as when a shaft of light from a window or floodlight falls on the image. Images may then appear washed out and less vibrant.

Throw distance is the distance measured from the front of the projector to the screen. This is an important calculation in any projector installation as it determines whether or not you have enough room to install your projector with a desired screen size and if your image will be the right size for your screen.

◀ **Throw Distance**

You can quickly estimate the throw distance by taking the width of the screen and multiplying it by the lens throw ratio; see Figure 3-2. The result of this calculation tells you roughly how far back the projector should be positioned from the screen in order to project a focused image large enough to fill the screen.

Estimating Throw Distance

Throw Distance (TD) = Screen Width (w) × Lens Throw Ratio

VX-4000d Throw Ratio: refer to Table 3-3

VX-5000d Throw Ratio: refer to Table 3-4

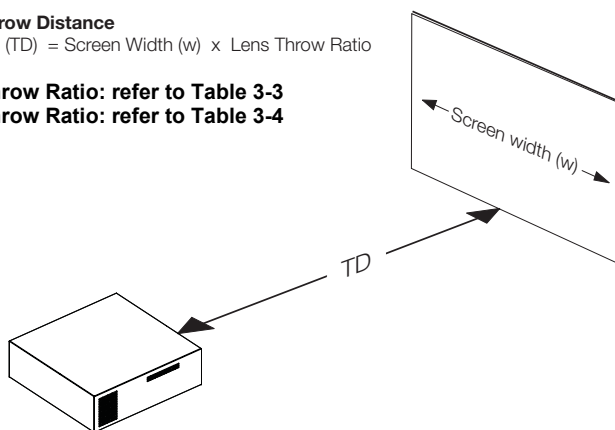

Figure 3-2. Estimating Throw Distance

Throw Distance Ranges - VX-4000d: Table 3-3 lists the available lens options for the VX-4000d and their associated throw ratios.

Table 3-3. VX-4000d Lens Options and Throw Ratios

Lens Option (Note 2)	Throw Ratio (Throw Dist. ÷ Screen Width)	Throw Distance Range (in inches, with 100-inch Wide Screen)	
		Minimum	Maximum
Proteus A	0.64 (Fixed)	For rear-screen installations only. Contact Runco Technical Support for more information.	
Proteus B	1.22 - 1.44	122	144
Proteus C	1.45 - 1.76	145	176
Proteus D	1.82 - 2.39	182	239
Proteus D with CineWide	1.38 - 1.80	138	180
Proteus E	2.42 - 3.57	242	357
Proteus E with CineWide	1.84 - 2.70	184	270

Notes:

1. Throw distance does not affect image quality, provided these ranges are taken into account.
2. Only the Proteus D, E and F lenses can be used with the optional CineWide (secondary anamorphic) lens. Doing so affects the throw distances as shown here.

Table 3-3. VX-4000d Lens Options and Throw Ratios (continued)

Lens Option (Note 2)	Throw Ratio (Throw Dist. ÷ Screen Width)	Throw Distance Range (in inches, with 100-inch Wide Screen)	
		Minimum	Maximum
Proteus F	3.63 - 5.72	363	572
Proteus F with CineWide	2.75 - 4.33	275	433

Notes:

1. Throw distance does not affect image quality, provided these ranges are taken into account.
2. Only the Proteus D, E and F lenses can be used with the optional CineWide (secondary anamorphic) lens. Doing so affects the throw distances as shown here.

Throw Distance Ranges - VX-5000d: Table 3-4 lists the available lens options for the VX-5000d and their associated throw ratios.

Table 3-4. VX-5000d Lens Options and Throw Ratios

Lens Option (Note 2)	Throw Ratio (Throw Dist. ÷ Screen Width)	Throw Distance Range (in inches, with 100-inch Wide Screen)	
		Minimum	Maximum
Telesto A	0.80 (Fixed)	For rear-screen installations only. Contact Runco Technical Support for more information.	
Telesto B	1.64 - 1.97	164	197
Telesto C	2.02 - 2.70	202	270
Telesto C with CineWide	1.53 - 2.04	153	204
Telesto D	2.84 - 4.80	284	480
Telesto D with CineWide	2.15 - 3.63	215	363
Telesto E	4.92 - 7.90	492	790
Telesto E with CineWide	3.73 - 5.98	373	598

Notes:

1. Throw distance does not affect image quality, provided these ranges are taken into account.
2. Only the Telesto C, D and E lenses can be used with the optional CineWide (secondary anamorphic) lens. Doing so affects the throw distances as shown here.

Proper placement of the projector relative to the screen will yield a rectangular, perfectly-centered image that completely fills the screen.

◀ **Vertical and Horizontal Position**

Ideally, the projector should be positioned perpendicular to the screen and in such a way that the lens center and screen center are aligned with each other, as shown in Figure 3-3.

Ceiling Installation

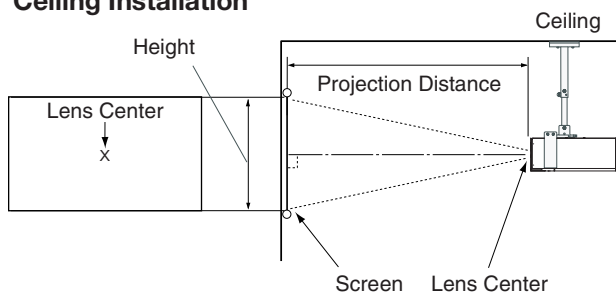

Floor Installation

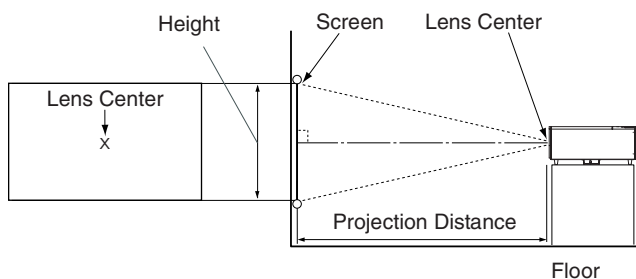
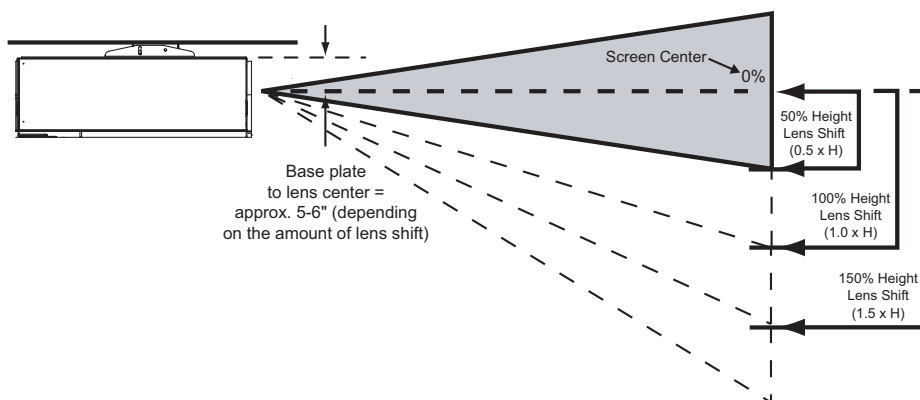

Figure 3-3. Projector Placement

If it is not possible to align the projector and screen as shown in Figure 3-3, you can use the lens shift controls to center the image on the screen. Lens shift is generally expressed as a percentage of the screen height or width, as shown in Figure 3-4 and Figure 3-5.

◀ **Vertical and Horizontal Lens Shift**



Note: This is a general example of lens shift. Lenses vary in their shift capabilities. No particular lens is used in this example.

Figure 3-4. Vertical Lens Shift

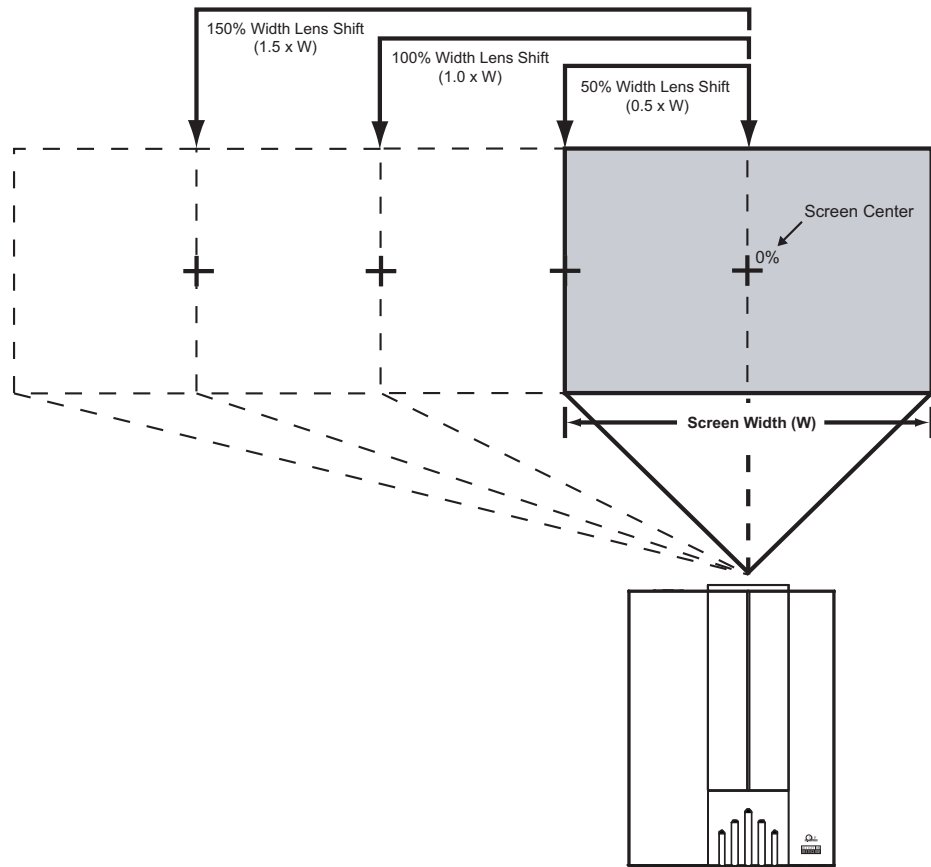

Note: This is a general example of lens shift. Lenses vary in their shift capabilities. No particular lens is used in this example.

Figure 3-5. Horizontal Lens Shift

Vertical Lens Shift - VX-4000d: The VX-4000d zoom lenses (Proteus B through F) provide up to 50% of vertical lens shift in either direction. For example, with a 96 x 54-inch (16:9) screen, you can shift the image up to 27.00 inches (0.69 meters) above or below the screen center. (Vertical lens shift is not possible with the Proteus A lens.)

Vertical Lens Shift - VX-5000d: The VX-5000d zoom lenses (Telesto B through E) provide up to 100% of vertical lens shift in either direction. For example, with a 96 x 54-inch (16:9) screen, you can shift the image up to 54.00 inches (1.38 meters) above or below the screen center. (Vertical lens shift is not possible with the Telesto A lens.)

Horizontal Lens Shift: The VX-4000d zoom lenses (Proteus B through F) and VX-5000d zoom lenses (Telesto B through E) allow up to 15% of horizontal lens shift in either direction (left or right). For example, with a 96 x 54-inch (16:9) screen, you can shift the image up to 14.40 inches (36.58 cm) left or right of the screen center. (Horizontal lens shift is not possible with the Proteus A or Telesto A lens.)

In rear screen applications where space behind the projector is limited, a mirror may be used to fold the optical path, as shown in Figure 3-6. The position of the projector and mirror must be accurately set. If you are considering this type of installation, contact your dealer for assistance.

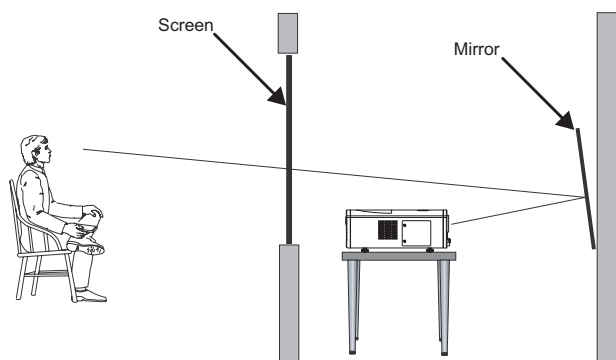

Figure 3-6. Folded Optics

Other considerations and tips that can help improve your installation:

- Keep the ambient temperature constant and below 35°C (95°F). Keep the projector away from heating and/or air conditioning vents. Changes in temperature may cause drifts in the projector circuitry, which may affect performance.
- Keep the projector away from devices that radiate electromagnetic energy such as motors and transformers. Common sources of these include slide projectors, speakers, power amplifiers and elevators.

If you are installing a VX-4000d/VX-5000d with the optional CineWide or CineWide with AutoScope system, install the secondary anamorphic lens in accordance with the instructions provided with the lens installation kit.

◀ **Folded Optics**

◀ **Other Considerations**

3.4 Installing the Optional CineWide Lens

3.5 Mounting the VX-4000d/VX-5000d

There are several methods for mounting the projector. Depending on your chosen installation, one method may be more suitable than another.

Floor Mounting ➤ In typical front and rear screen installations, the projector can be mounted to a secure and level surface such as a table or cart. Carts are useful when moving a projector during a presentation or from site to site. If possible, lock the wheels when it's in position to prevent it from being moved during a presentation.

Ceiling Mounting ➤ The projector can also be inverted and suspended from the ceiling using a specially designed ceiling mount fixture. This type of mounting is recommended for fixed installations and for those that want the projector out of sight or have a limited space for projector and audience.

Adjusting the Projection Angle ➤ If the VX-4000d/VX-5000d is ceiling-mounted and the screen is significantly lower than the projector, you can tilt the projector at a slight angle by adjusting the ceiling mount.

If you do this, you may need to shift the image or apply keystone correction using the OSD controls, to compensate. For detailed instructions, refer to **Using the On-Screen Menus** on page 39.



Note

Use only the Runco-approved ceiling mount kit designed for your projector.

3.6 Connections to the VX-4000d/VX-5000d and DHD Controller

Proceed as follows to connect the DHD Controller to the VX-4000d/VX-5000d, your video sources, external controller(s) -- if present -- and AC power.

When connecting your equipment:

- Turn off all equipment before making any connections.
- Use the correct signal cables for each source.
- Ensure that the cables are securely connected. Tighten the thumbscrews on connectors that have them.

Connector Panel Access ➤ You can access the connector panel through the cable opening at the bottom rear of the projector (see Figure 2-1 or Figure 2-2).

Connecting the DHD Controller to the VX-4000d/VX-5000d ➤ The VX-4000d/VX-5000d is designed to receive only video input signals directly from the companion DHD Controller/Processor. All signal sources should be connected to the appropriate inputs on the rear panel of the DHD. The signal from the DHD is then output to the VX-4000d/VX-5000d projector through an RGB or DVI cable.



Note

You CANNOT connect signal sources directly to the VX-4000d/VX-5000d. They MUST be routed through the DHD Controller for proper operation.

Connect the DVI, RGBHV and RS-232 outputs of the DHD Controller to the corresponding inputs of the VX-4000d/VX-5000d; see Figure 3-7.

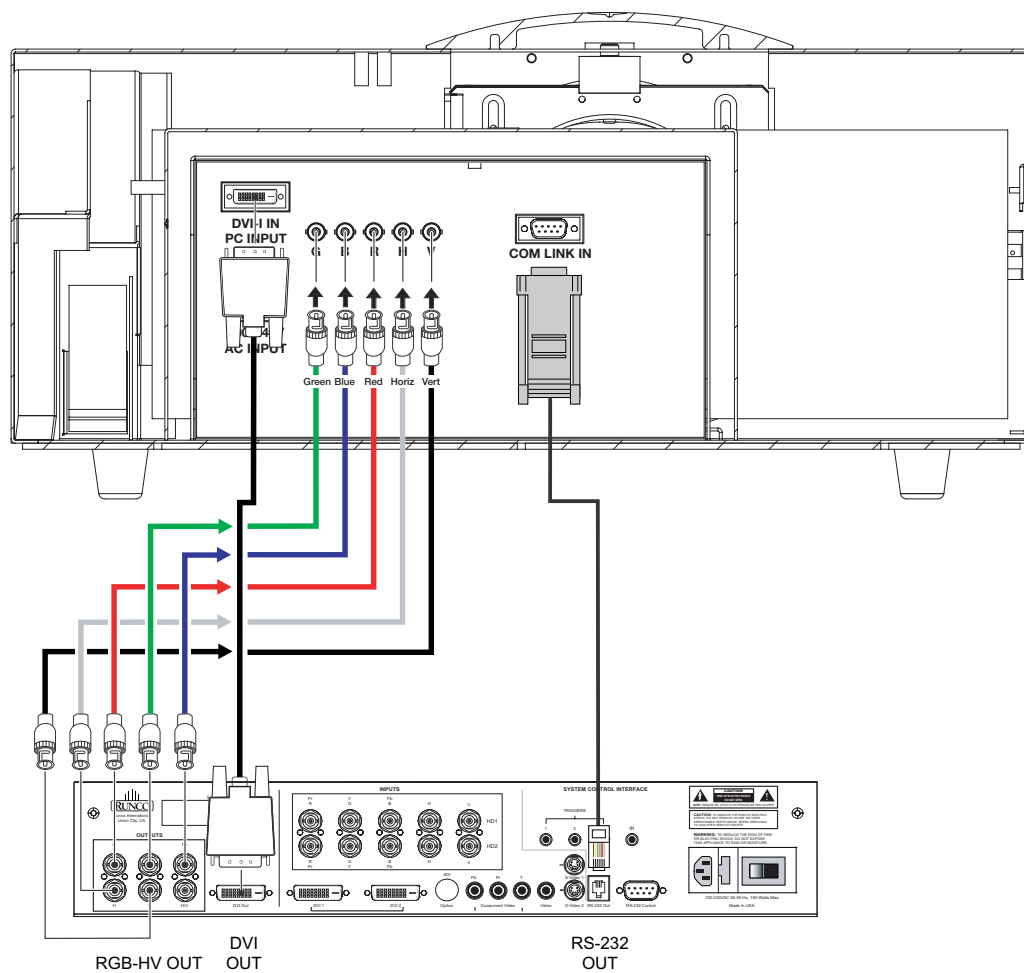

Figure 3-7. Connecting the VX-4000d/VX-5000d to the DHD Controller

Connecting Source Components to the DHD Controller

Connect your video sources to the DHD Controller as shown and described in the sections that follow.

DVI Connections: See Figure 3-8.



Tip

Use the DVI inputs whenever possible. This ensures the highest video quality because the signal is carried in the digital domain throughout the entire signal path, from source component output into the projector.

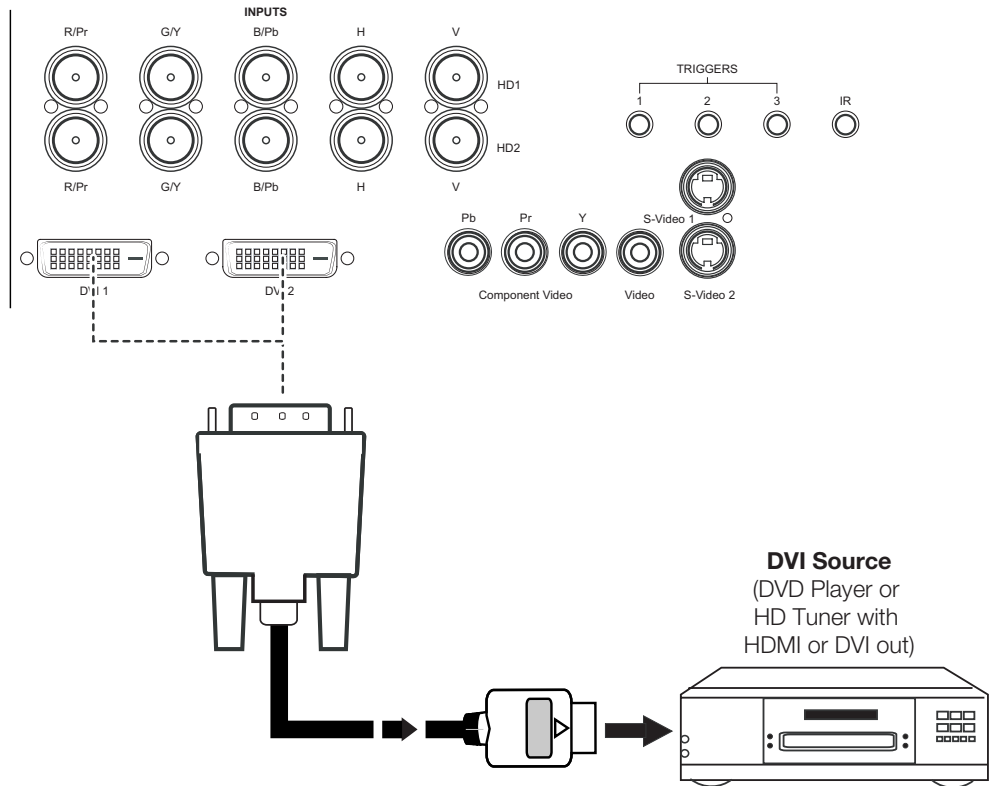

Figure 3-8. DVI Source Connections

Digital (DTV) RGB or Component Video Connections: See Figure 3-9.

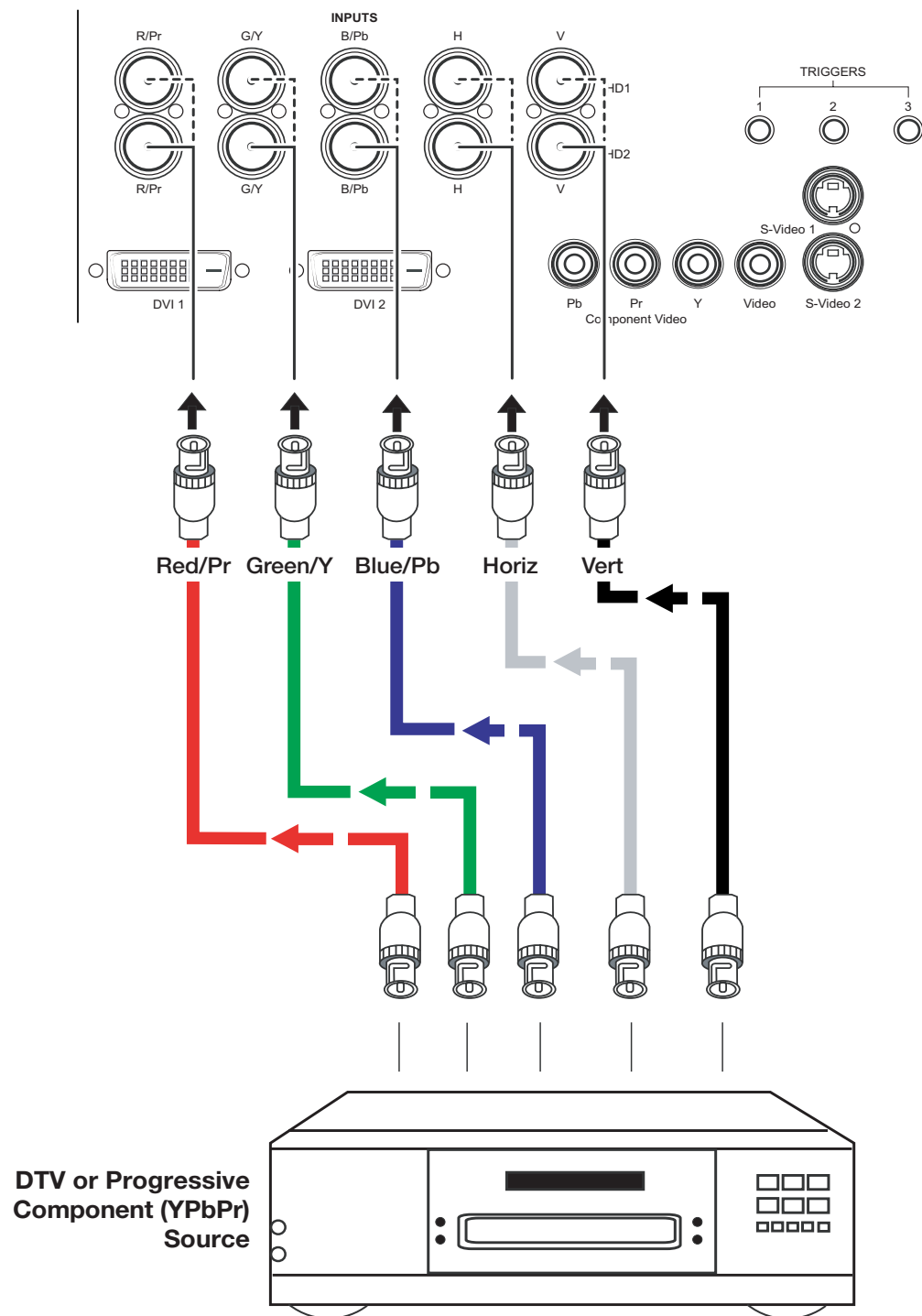

Figure 3-9. Digital (DTV) RGB or Component Video Connections

Analog (Computer) RGB Connections: See Figure 3-10.

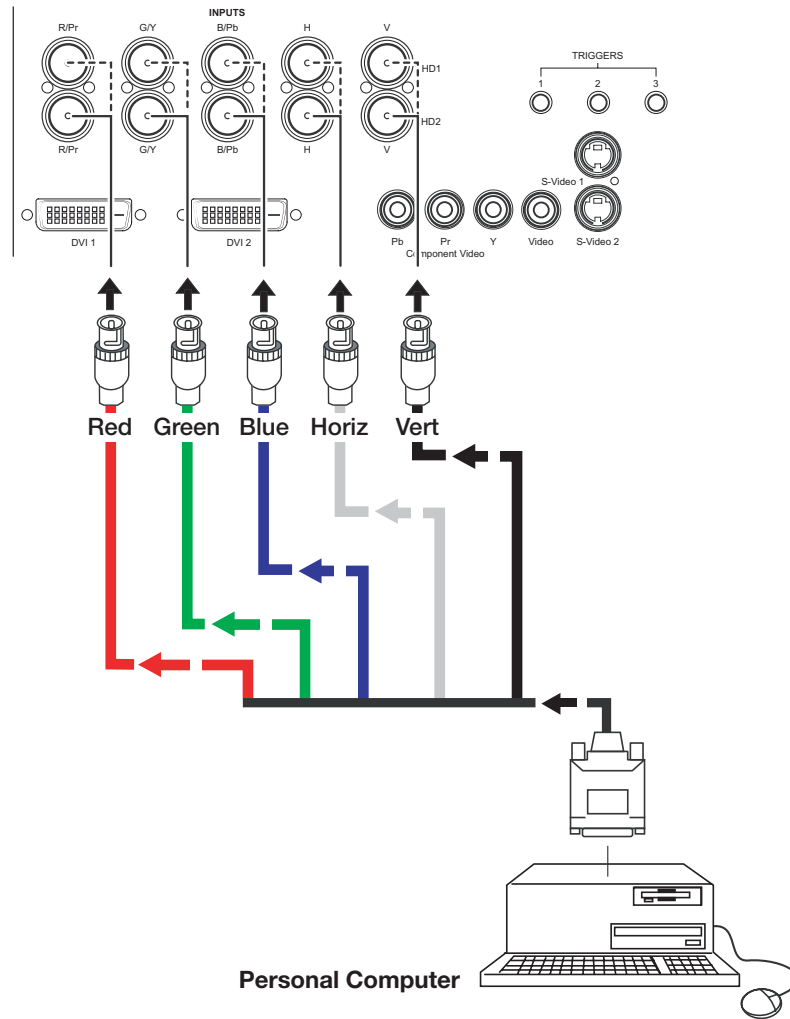

Figure 3-10. Analog RGB Connections

Composite/S-Video/Component Video Connections: See Figure 3-11.

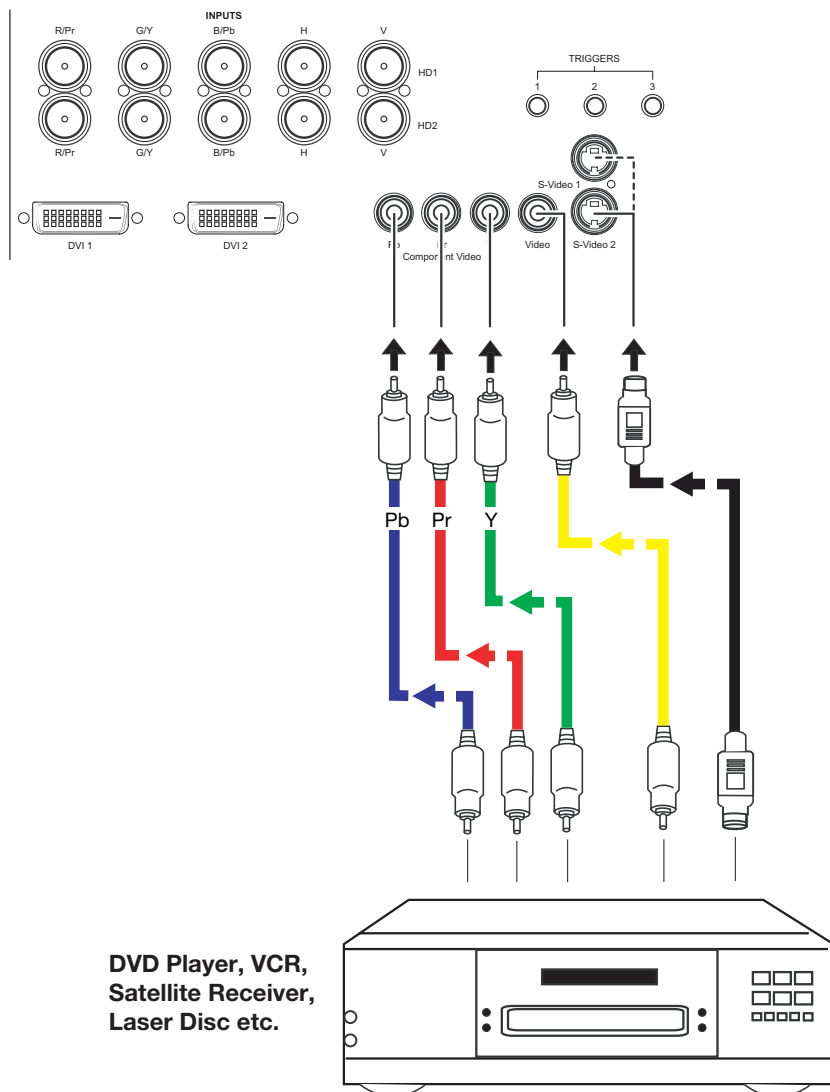

Figure 3-11. Composite, S-Video and Component Video Connections

RS-232 Controller Connection

Use a standard, 9-pin RS-232 cable to connect a PC or home theater control/automation system (if present) to the RS-232 Control port on the DHD Controller; see Figure 3-12.

For more information about using this connection, refer to **Serial Communications** on page 61.

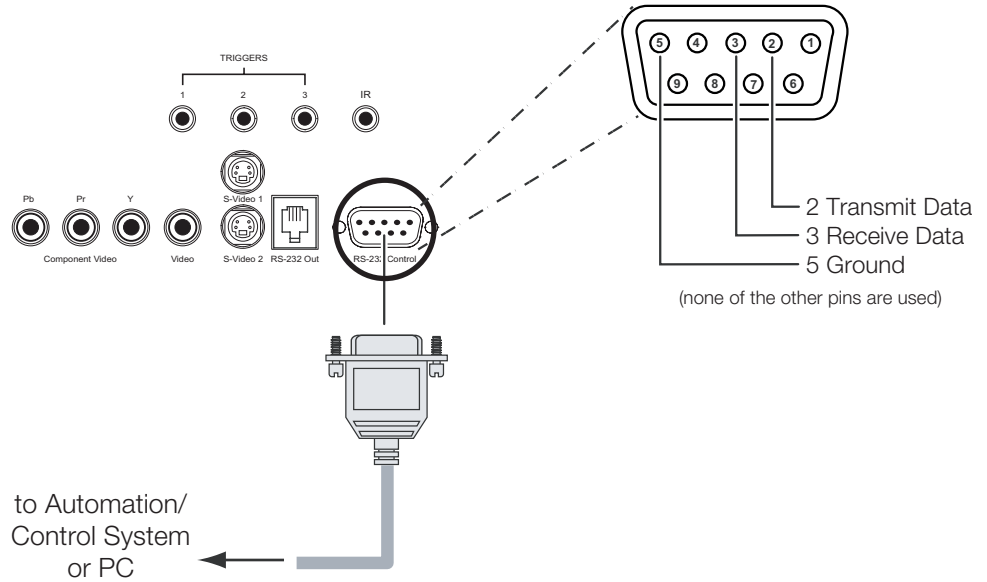

Figure 3-12. RS-232 Control System Connection

Connecting 12-Volt Trigger Outputs to External Theater Components

If your VX-4000d/VX-5000d is equipped with a CineWide with AutoScope system, or if your home theater contains other devices that respond to 12-volt triggers (such as retractable screens or screen masks), connect them to the 12-volt trigger outputs as shown in Figure 3-13.

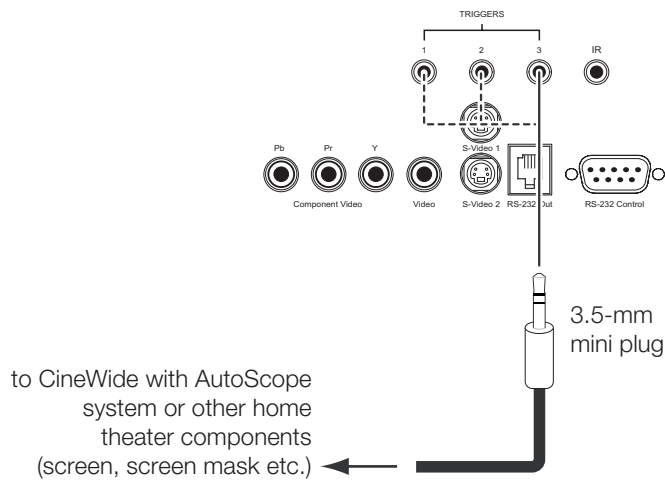

Figure 3-13. Connecting 12-Volt Trigger Outputs

The VX-4000d/VX-5000d system includes two (2) AC power cords (one each for the projector and DHD Controller).

◀ **Connecting to AC Power**

Plug the female end of one power cord into the AC receptacle on the rear of the VX-4000d/VX-5000d (AC 100V ~ 240V). Then, connect the other end to your AC power source. Similarly connect the DHD Controller to a nearby AC outlet.

Notes:

4. Operation

1. Turn on your source components.
2. Turn on the main power switch at the rear of the DHD Controller.
3. Press the **ON** button on the remote control -- or the **POWER** button on the DHD Controller front panel -- to turn on the system. The vacuum fluorescent display on the DHD Controller front panel briefly displays "Starting Display."
4. When the projector is ready for use, the fluorescent display indicates the active source, signal format (NTSC or PAL), input resolution and aspect ratio; for example:

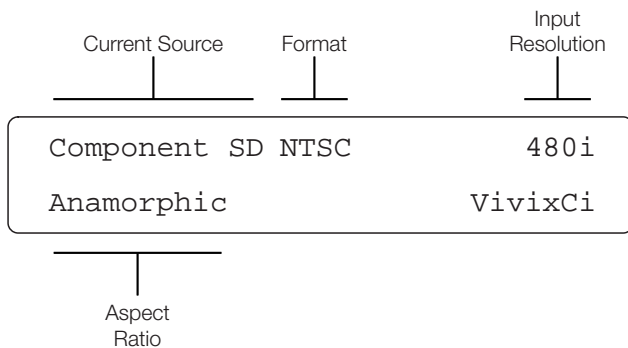

By default, the VX-4000d/VX-5000d is configured for a "floor/front" installation, in which the projector is installed upright and in front of the screen. If it is installed behind the screen and/or mounted on a ceiling, you must change the picture orientation. To do this:

1. Press **MENU** (on menu page 4) and enter the Service Menu passcode.
2. Select Service from the Main Menu.
3. Select Display Device from the Service Menu, then select Configure.
4. Press **▼**, then choose Floor/Rear, Ceiling/Front or Ceiling/Rear, to match the installation method.



Note

You must enter a passcode to access the Service menu.

By default, the VX-4000d/VX-5000d is configured to display the signal received on its RGBHV input. To use the DVI input instead:

1. Press **MENU** (on menu page 4) and enter the Service Menu passcode, if the Service Menu is not already visible.
2. Select Service from the Main Menu.
3. Select Display Device from the Service Menu, then select Configure.
4. Input 1 is the RGBHV input. Press **▶** to select projector input 2 (DVI).

4.1

Turning on the Power

4.2

Adjusting the Picture Orientation

4.3

Selecting the Input Source

4.4 Lens Adjustments

Lens zoom and focus are motorized adjustments that are adjustable from the remote control. This allows you to adjust the focus and image size while at the screen for more accurate results. The remote control has over 100 feet of range to the projector for long throw distances.

The IR receiver for the lens motor assembly is located on the projector behind the front Runco logo cover. Rotate the logo cover 90 degrees as shown to reveal the IR receiver opening.



- Focus** ➤
1. With the IR receiver revealed on the front of the projector, go to the zoom/focus page (5/7) of the remote control.
 2. Point the remote directly at the projector for maximum range.
 3. To focus the projected image, press and hold the **FOCUS +** or **FOCUS -** button.

- Zoom** ➤ To make the picture smaller (zoom out), press and hold the **ZOOM -** button. To enlarge the picture (zoom in), press and hold the **ZOOM +** button.

- Vertical and Horizontal Lens Shift** ➤ To change the projected image position, use a 3/16" hex driver to shift the lens in the desired direction; see Figure 4-1. The vertical lens shift control is at the top of the projector; the horizontal lens shift control is on the side of the projector nearest the Runco logo. (The tool will automatically center on top of the adjustment nut when inserted into the access hole.)

Vertical Lens Shift

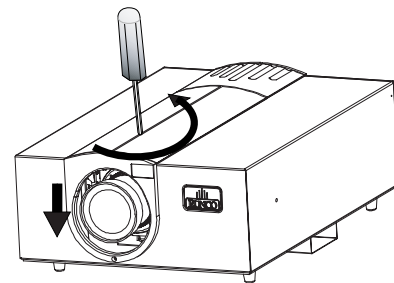
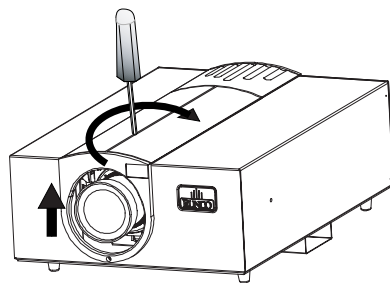

Horizontal Lens Shift

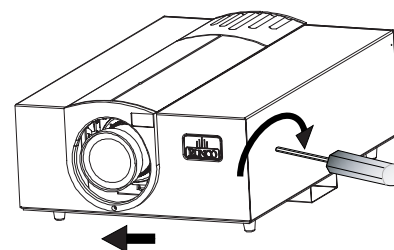
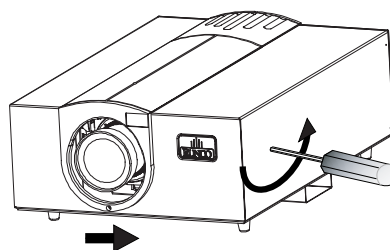

Figure 4-1. Vertical and Horizontal Lens Shift Adjustments

Press the **MENU** button on either the remote control or the DHD Controller front panel to display the Main Menu.

To select a menu item, use the ▲ and ▼ buttons on either the remote control or the DHD Controller front panel to highlight it. Press **ENTER** to confirm your selection.

The VX-4000d/VX-5000d OSD menus are arranged hierarchically, as shown in Figure 4-2. Depending on the selected input source and signal characteristics, some menu options may not be available.

4.5 Using the On-Screen Menus

Input Source	Composite
	S-Video 1
	S-Video 2
	Component SD
	HD/RGB 1
	HD/RGB 2
	DVI 1
	DVI 2
	HD Pass Thru 1
	HD Pass Thru 2
Aspect Ratio	Anamorphic
	Standard 4:3
	Letterbox
	VirtualWide
	Cinema
Picture	Virtualwide 2.35
	Brightness
	Contrast
	Color
	Tint
Input Position	Sharpness
	Left/Right
	Up/Down
	Width
	Height
ISF Presets	Overscan
	Recall ISF Night
	Recall ISF Day
	Recall/Save Custom 1
	Recall/Save Custom 2
Information (read-only)	Reset Custom 1 & 2 to Factory Default
	Serial Number
	Hardware
	Firmware
	Date

Note: Virtualwide 2.35 is available only on VX-4000d/VX-5000d projectors equipped with the CineWide option (secondary anamorphic lens).

Calibration	ISF Night - Display Color	Gain
		Offset
		Gamma
		Iris
		Color Temp
	ISF Night - Input Image	Brightness
		Contrast
		Color
		Tint
		Sharpness
	ISF Night - Input Color	Gain
		Offset
		Chroma Delay
		Phase
		Noise Filter
	ISF Day - Display Color	Gain
		Offset
		Gamma
		Iris
		Color Temp
ISF Day - Input Image	Brightness	
	Contrast	
	Color	
	Tint	
	Sharpness	
ISF Day - Input Color	Gain	
	Offset	
	Chroma Delay	
	Phase	
	Noise Filter	
Save ISF Settings	Back / Confirm	
Output Shift	Left/Right	
	Up/Down	
	Width	
	Height	
	Save	
Splash Configure	Owner Name	
	ISF Calibrated	
	ISF Other	
OSD Position		

Service	Test Video	Grey Bars 1	
		Grey Bars 2	
		Color Bars 1	
		Color Bars 2	
	Input Names	Rename, Restore or Save	
	Remote Control	Primary	
		Secondary	
	Analog Out Mode	RGB-, RGB++ or RGBS	
	Display Device	Configure	Input Source (1 = RGBHV; 2 = DVI)
			Picture Orientation
			Keystone
			Lamp Hours (View/Reset)
	HD Format	HD/RGB 1	Auto, RGB or YUV
		HD/RGB 2	
		ADC Bandwidth	Auto, 75 MHz, 150 MHz or 300 MHz
		YPbPr Input Resolution	Auto, 480i/p, 576i/p, 720p or 1080i
	Triggers	1 / 2 / 3 / Save	
	Miscellaneous	Language	English, French, German or Spanish
		Menu Mode	
Timeout			
Side Bar Color			
Film Mode (SD src. only)			
Resolution	800x600 ... 1400x1050 480i ... 720p ... 1080i		
System Reset			
Restore Saved Settings			

Figure 4-2. DHD Controller OSD Menu Structure for VX-4000d/VX-5000d

The Main Menu is the starting point for accessing all projector functions.

(The Calibration and Service menus are hidden and not accessible until you enter a passcode.)

◀ **Main Menu**

Runco Video
Input Source
Aspect Ratio
Picture
Input Position
ISF Presets
Information
Calibration
Service

From the Main Menu, select Input Source to choose a video signal source.

The active source is indicated by an arrow (>) to its left; in the example at right, Composite is the active source.

◀ **Input Source**

Input Source
> Composite
S-Video 1
S-Video 2
Component SD
HD/RGB 1
HD/RGB 2
DVI 1
DVI 2
HD Pass Thru 1
HD Pass Thru 2



Note

1. Selecting *HD Pass Thru 1* or *HD Pass Thru 2* loops the *HD/RGB 1* or *HD/RGB 2* input signal respectively to the *RGB* output. This prevents display of the on-screen menus. To switch from *HD Pass Thru 1* or *2* to another source, use the direct access buttons on the remote control, or the left- or right-arrow buttons on the *DHD Controller*.
2. If the *DVI 1* or *DVI 2* input is active and the input signal is *HDCP-encrypted*, the *RGBHV* output of the *DHD Controller* is disabled.

To change the aspect ratio (size and shape) of the projected image, select Aspect Ratio from the Main Menu and press **ENTER**. Select the appropriate aspect ratio for your screen size and the type of program material being viewed; refer to Table 4-1.

The currently-selected aspect ratio is indicated by a "☒" to its left; in the example at right, Anamorphic is selected.

◀ **Aspect Ratio**

Aspect Ratio
<input checked="" type="checkbox"/> Anamorphic
<input type="checkbox"/> Standard 4:3
<input type="checkbox"/> Letterbox
<input type="checkbox"/> VirtualWide
<input type="checkbox"/> Cinema
<input type="checkbox"/> Virtualwide 2.35



Note

When you change the aspect ratio, save the change to a preset afterwards. Otherwise, the change will be lost when a different input is selected. (The aspect ratio is saved for each input and resolution separately.) For information about saving settings, refer to **ISF Presets** on page 48.

Table 4-1. Aspect Ratio Settings



Aspect Ratio		Description
Anamorphic	 <p>The diagram consists of two rectangular frames. The top frame is labeled '16:9 Image on 16:9 Screen' and shows a central white circle surrounded by four smaller white circles, all contained within a gray rectangle. The bottom frame is labeled '4:3 Image on 16:9 Screen' and shows the same central white circle and four smaller white circles, but they are horizontally stretched to fit the wider 16:9 frame.</p>	<p>Select Anamorphic to view 16:9 DVDs and HDTV programs in their native aspect ratio. 4:3 images are stretched horizontally to fit a 16:9 screen.</p>
Standard 4:3	 <p>The diagram shows a gray rectangle representing a 16:9 screen. Inside, a smaller gray rectangle represents the 'Active Image Area (4:3)'. This active area is centered horizontally and vertically, leaving black bars on the left and right sides of the screen.</p>	<p>Standard 4:3 scales the input signal to fit in the center of the 16:9 screen. 4:3 is the aspect ratio used by computer monitors, standard television programming and most VHS video cassettes.</p>
Letterbox	 <p>The diagram shows a gray rectangle representing a 16:9 screen. Inside, a smaller gray rectangle represents the 'Letterbox Image on 16:9 Screen'. This image is vertically stretched to fit the height of the screen, leaving black bars at the top and bottom.</p>	<p>In Letterbox mode, the image is stretched vertically; the top and bottom portions are "blacked off." Letterbox is best suited for viewing LaserDisc movies or non-anamorphic DVDs on a 4:3 screen.</p>
VirtualWide	 <p>The diagram shows a gray rectangle representing a 16:9 screen. Inside, a smaller gray rectangle represents the 'VirtualWide' image. This image is a 4:3 aspect ratio that has been scaled non-linearly, being wider at the top and bottom than in the center, to fit the 16:9 screen.</p>	<p>A 4:3 image is scaled NON-linearly (more on the sides than in the center) to fit a 16x9 screen.</p>
Cinema	 <p>The diagram shows a gray rectangle representing a 16:9 screen. Inside, a smaller gray rectangle represents the '2.35:1 Image on 16:9 Screen'. This image is very wide and short, with black bars at the top and bottom, indicating that the upper and lower portions of the screen are masked.</p>	<p>Select Cinema to view 2.35 source material on a 16:9 screen. The upper and lower portions of the screen are masked, but the geometry of the active image area is not changed.</p>

Table 4-1. Aspect Ratio Settings (continued)

Aspect Ratio	Description
Virtualwide 2.35	 <p>A 2.35 image is stretched anamorphically in both directions to fill a 16:9 image. (The secondary anamorphic lens then “stretches” the image back to 2.35:1.)</p> <p>Virtualwide 2.35 is available only on VX-4000d/VX-5000d projectors equipped with the CineWide option.</p>

Use the controls in the Picture Menu to calibrate your VX-4000d/VX-5000d for optimum picture quality.

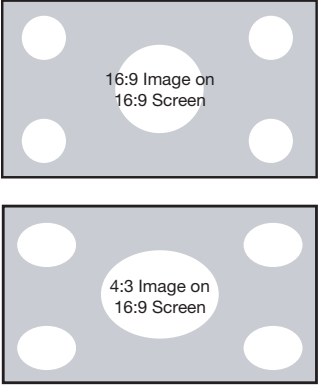
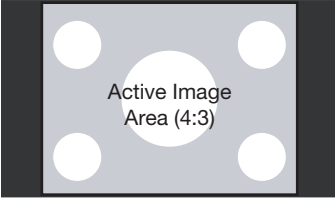
The VX-4000d/VX-5000d has been designed to incorporate setup and calibration standards established by the Imaging Science Foundation (ISF). The ISF has developed carefully crafted, industry-recognized standards for optimal video performance and has implemented a training program for technicians and installers to use these standards to obtain optimal picture quality from Runco video display devices. Accordingly, Runco recommends that setup and calibration be performed by an ISF certified installation technician.

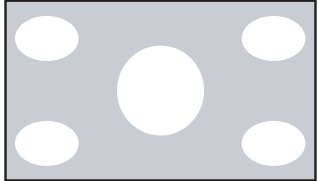
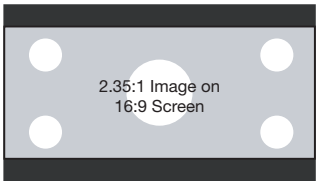
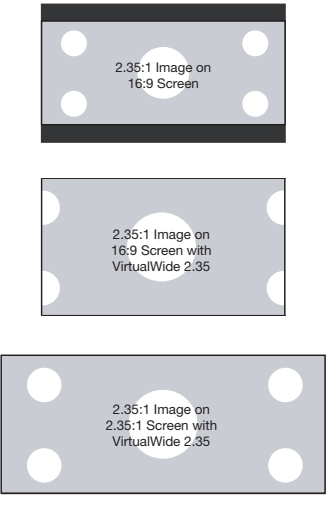
All signal types require separate processing. Therefore, you need to calibrate each input separately. Runco recommends calibrating the VX-4000d/VX-5000d inputs in the following order:

1. Component SD
2. S-Video 1 / S-Video 2
3. Composite
4. HD/RGB 1 / HD/RGB 2
5. DVI 1 / DVI 2

◀ **Picture**

Picture
Brightness
Contrast
Color
Tint
Sharpness



Note

*When you change a picture quality setting, save the change to a preset afterwards. Otherwise, the change will be lost when a different input is selected. (Picture quality settings are saved for each input and resolution separately.) For information about saving settings, refer to **ISF Presets** on page 48.*

Although it may be possible to obtain satisfactory picture quality using the naked eye and regular program material, Runco recommends using the following calibration tools for best results:

- External test pattern source -- Ovation Multimedia, Digital Video Essentials or AVIA test DVD or equivalent.
- A blue filter (provided with many test DVDs), for color level and tint adjustments.

Connect your test pattern source to the input that you are calibrating and proceed as follows. **Perform the adjustments in the order listed here.**

Brightness: On your external test pattern source, select a PLUGE pattern. (PLUGE is an acronym for "Picture Line-Up Generation Equipment.") Figure 4-3 shows a typical PLUGE pattern.

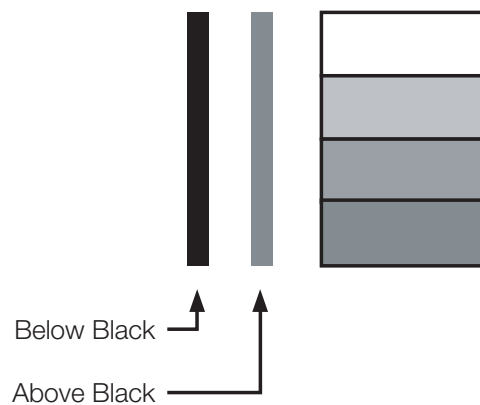

Figure 4-3. Typical PLUGE Pattern for Adjusting Brightness

PLUGE patterns vary but generally consist of some combination of black, white and gray areas against a black background. The example above includes two vertical bars and four shaded boxes.

Select Brightness from the Picture menu and press **ENTER**. Adjust the brightness so that:

- The darkest black bars disappear into the background.
- The dark gray areas are barely visible.
- The lighter gray areas are clearly visible.
- The white areas are a comfortable level of true white.
- The image contains only black, gray and white (no color).

Contrast: On your external test pattern source, select a stepped, gray-bar pattern like the one shown in Figure 4-4.

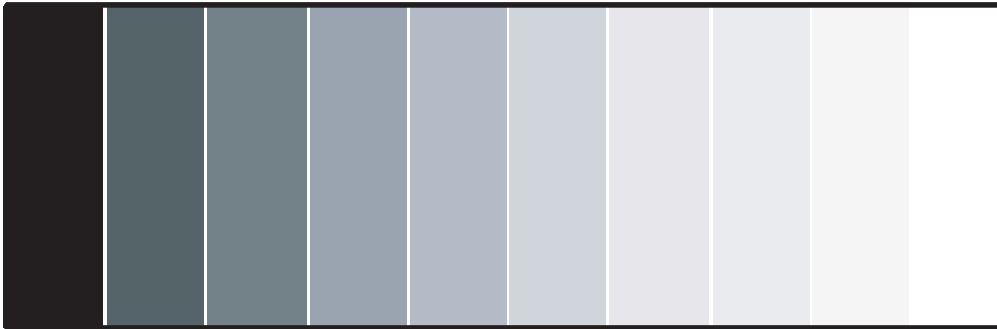

Figure 4-4. Typical Gray Bar Pattern for Adjusting Contrast

Select Contrast and press **ENTER**. Adjust the contrast to a point just below which the white rectangle starts to increase in size.



Note

Brightness and contrast controls are interactive. A change to one may require a subtle change to the other in order to achieve the optimum setting.

Color Saturation: On your external test pattern source, select a color bar pattern like the one shown in Figure 4-5.

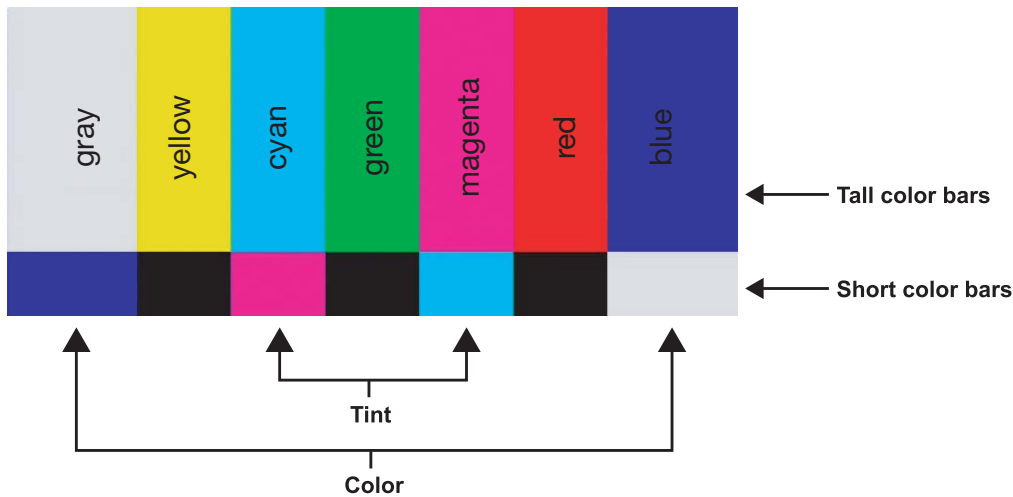
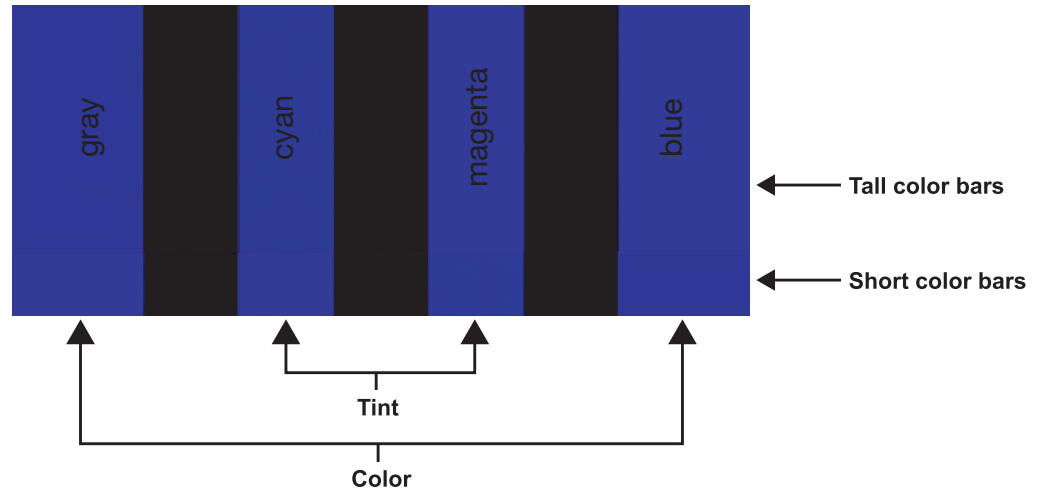

Figure 4-5. Typical Color Bar Pattern for Adjusting Color Saturation and Tint

Select Color and press **ENTER**. While looking at the color bar pattern through a blue filter, adjust the color saturation level until the outermost (gray and blue) color bars appear to be a single shade of blue:



Tint: Tint or “hue” is essentially the ratio of red to green in the color portion of the image. When tint is decreased, the image appears redder; when it is increased the image appears greener. To set the tint, select Tint and press **ENTER**. While looking at the color bar pattern through a blue filter, adjust the tint level until the cyan and magenta color bars (on either side of the green bar) appear to be a single shade of blue.



Note

Like the brightness and contrast controls, the color and tint controls are interactive. A change to one may require a subtle change to the other in order to achieve the optimum setting.

Sharpness: “Sharpness” is the amount of high-frequency detail in the image. To adjust sharpness, select Sharpness from the Picture menu and press **ENTER**. On your external test pattern source, select a pattern like the one shown in Figure 4-6. Adjust as needed, looking for white edges around the transitions from black to gray and differently-sized lines in the “sweep” patterns at the top and bottom. Lower the sharpness setting to eliminate them.

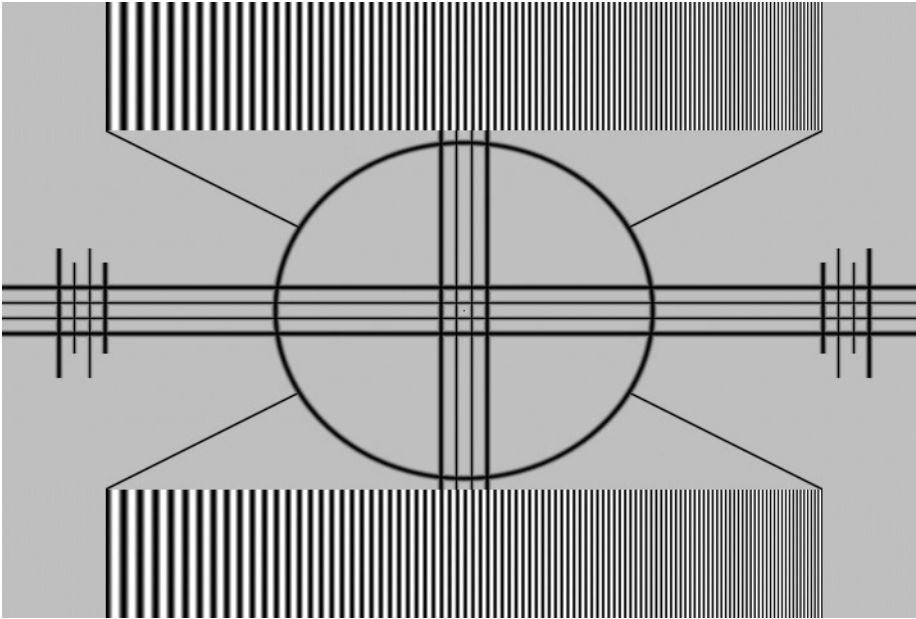

Figure 4-6. Typical Test Pattern for Adjusting Sharpness

Use the controls in the Input Position Menu to fine-tune the aspect ratio and image position for the current source.



Note

*When you change an input position setting, save the change to a preset afterwards. Otherwise, the change will be lost when a different input is selected. (The input position settings are saved for each input and resolution separately.) For information about saving settings, refer to **ISF Presets** on page 48.*

Left/Right: Select Left/Right from the Input Position menu to shift the projected image horizontally. Use the right or up cursor button to shift the image to the right; use the left or down button to shift it to the left.

Up/Down: Select Up/Down from the Input Position menu to shift the projected image vertically. Use the right or up cursor button to shift the image upward; use the left or down button to shift it downward.

Width: Select Width from the Input Position menu to change the projected image width. Use the right or up cursor button to increase the width; use the left or down button to decrease it.

Height: Select Height from the Input Position menu to change the projected image height. Use the right or up cursor button to increase the height; use the left or down button to decrease it.

◀ **Input Position**

Input Position
Left/Right
Up/Down
Width
Height
Overscan

Overscan: Image Overscan pushes the outside edge of the active picture area of the video signal out beyond the edge of the display area.

Some television programs are produced based on the assumption that older television sets may not display the outer edges of the broadcast picture area. Overscan effectively trims away these inactive, outer edges and enlarges the remaining portion of the image to fill the display area.

Select from 1% to 10% of Overscan, as desired.

For HDTV, DVDs and other video sources, Overscan is generally not necessary or desirable.

ISF Presets ➤

ISF Presets	
<input checked="" type="checkbox"/>	ISF Night
<input type="checkbox"/>	ISF Day
<input type="checkbox"/>	Custom 1 Save
<input type="checkbox"/>	Custom 2 Save
Factory Default	

For each input, the VX-4000d/VX-5000d lets you save image quality settings as presets that you can recall at a later time. You can create up to four presets per input and resolution. Use the ISF Presets menu to recall saved image presets, or to save image settings in the “Custom 1” or “Custom 2” memory location. The currently-selected preset is indicated by a “” to its left; in the example shown here, ISF Night is selected.

You should save changes to any of the following settings to a preset; otherwise they will be lost when a new input source or resolution is selected:

- Aspect ratio
- Picture quality settings (brightness, contrast, color saturation, tint and sharpness)
- Input position (image position, width, height and overscan percentage)

To reset the Custom 1 and Custom 2 image presets to their factory defaults, select Factory Default and press **ENTER**.

Information ➤

Information	
Serial Num	
Hardware	0
Firmware	0002.001A
Date	Feb 9 2006

Select Information from the Main Menu to see information that uniquely identifies your projector: its serial number, the installed hardware and firmware versions and the firmware version build date. Should you ever need to contact Runco Technical Support, this information will help them answer your questions or resolve product performance issues.

Use the Calibration menu to perform advanced picture quality adjustments. **This menu should be used by ISF-certified technicians only.**



Note

You must enter a passcode to access the Calibration menu.

To recall the ISF Night or ISF Day settings, select “ISF Night” or “ISF Day” from the ISF Presets menu (see above).

ISF Night - Display Color: Use the Display Color settings to change the characteristics of the output signal. These settings are global (independent of any particular input).

- **Gain:** Use the Gain controls to correct color imbalances in the bright areas of the image. A good way to do this is to use a test pattern consisting mostly of solid white areas, such as an 80 IRE “window” pattern. If the white areas contain traces of red, green or blue, decrease the Gain for that color.
- **Offset:** Use the Offset controls in the White Balance sub-menu to correct color imbalances in the dark areas of the image. A good way to do this is to use a test pattern consisting mostly of dark gray areas, such as a 30 IRE “window” pattern. If the gray areas contain traces of red, green or blue, decrease the Offset for that color.
- **Gamma:** “Gamma” is a global setting that determines how gray shades are displayed between minimum input (black) and maximum input (white) for all signals. A good gamma setting helps to optimize blacks and whites while ensuring smooth transitions for the “in-between” values utilized in other grays. Unlike “Brightness” and “Contrast” controls, the overall tone of your images can be lightened or darkened without changing the extremes and all images will be more vibrant while still showing good detail in dark areas.

In all but the most unusual situations, the appropriate “Color Temp” selection (see below) will produce accurate colors and a satisfying contrast level. However, it is sometimes necessary to adjust the red, blue and green gamma curves individually. To do this, select Gamma from the Display Color sub-menu and use the left- and right-arrow buttons to manipulate the on-screen slidebars.

- **Iris:** Select Iris from the Display Color Menu to increase or decrease the Reflectance Volume Regulation setting. RVR lets you control the aperture or iris size (the physical opening through the lens; similar to an “f-stop” on a camera). Doing so allows you to optimize brightness and contrast according to the amount of ambient light in the viewing area.

Use the lower setting (1) for rooms with lots of ambient light. Use the higher setting (2) for more “theater-like” viewing conditions (little or no ambient light).

- **Color Temp:** Select Color Temp from the Display Color menu to adjust the color temperature. The default setting is appropriate for most situations. Higher settings produce a “bluer” picture.

ISF Night - Input Image: The Input Image controls are similar to those in the Picture menu, but are accessible only by entering the Calibration menu passcode. This makes it possible to restore the picture quality settings to what they were when the projector was installed, simply by recalling the “ISF Night” preset.

◀ **Calibration**

Calibration
ISF Night
Display Color
Input Image
Input Color
ISF Day
Display Color
Input Image
Input Color
Save ISF Settings
Output Shift
Splash Configure
OSD Position

ISF Night - Input Color: The Input Color controls are similar to those in the Display Color menu (see above), but can be set independently for each input.

- **Gain/Offset:** Refer to *ISF Night - Display Color*, above.
- **Chroma Delay:** use the Chroma Delay control to correct a mis-aligned image from a Composite, S-Video or Component video source. Chroma delay in an image causes color shifts to occur to the left of the vertical edge transitions, producing artificial shadows or a “halo” effect. If necessary, adjust this setting to eliminate them.
- **Phase:** Adjust the phase if the image (usually from an RGB source) shows shimmer or “noise.” Pixel phase adjusts the phase of the pixel sampling clock relative to the incoming signal. The effect of this control is similar to that of a tracking control on a VCR.

For best results, use a good test pattern such as a smooth gray consisting of a clear pattern of black and white pixels, or a similar “half on, half off” graphic image. (You may notice that you can stabilize the image at more than one point. Use either setting in this case.)

- **Noise Filter:** Select Noise Filter from the Input Color menu to filter a noisy Composite, S-Video or Composite source signal. Adjust as desired, keeping in mind that reducing noise (which reduces high frequencies) may also soften the image.

ISF Day - Display Color: Refer to *ISF Night - Display Color*.

ISF Day - Input Image: Refer to *ISF Night - Input Image*.

ISF Day - Input Color: Refer to *ISF Night - Input Color*.

Save ISF Settings: Whenever you make a change to the ISF settings, you should always save it. Select Save ISF Settings from the ISF Calibration menu to do this. In the event you ever have to perform a System Reset, you can restore the saved ISF settings by selecting Restore Saved Settings in the Service menu. (System Reset and Restore Saved Settings are described on page 54.)

Output Shift: The controls in the Output Shift menu are similar to those in the Input Position menu, except that they change the characteristics of the output signal (so the change is visible no matter which input is selected). You can set these controls independently for each aspect ratio.

To save the Output Shift settings for the current aspect ratio so that they can be restored after a System Reset (described on page 54), press ▼ repeatedly to highlight “Save.” Then, press **ENTER**.

Splash Configure: Use the Splash Configure menu to customize the appearance of the start-up message that appears on the vacuum fluorescent display upon power-up. You can have the VX-4000d/VX-5000d display the owner’s name, your name, the phrase “ISF Calibrated” and/or any other string, up to 20 characters in length.

Use the up or down cursor button to select a character. Use the right and left cursor buttons to change the cursor position. Press **MENU** when you have finished entering text. Then, check the “Splash Enable” box to have the VX-4000d/VX-5000d display the information you enter here when it is turned on.

OSD Position: Select OSD Position, press **ENTER** and use the arrow buttons to change the size and position of the OSD controls.

Use the Service menu to access advanced projector configuration settings. **This menu should be used by ISF-certified technicians only.**



You must enter a passcode to access the Service menu.

Test Video: Select Test Video from the Service Menu to access the internal test patterns on the VX-4000d/VX-5000d. Four patterns are available, consisting of white/gray or colored bars.

Press **MENU** to exit test pattern mode.

Input Names: You can give each DHD Controller input a descriptive name. For example, you may want to change the default input name to the type of source component connected to it: "VCR," "DVD," "Laptop" et cetera. Composite, S-Video and Component SD input names can be up to 12 characters long; the others can be up to eight characters long.

To edit an input name, select Input Names from the Service menu. Press ▲ or ▼ to select an input and press **ENTER**. Use the ▲ or ▼ buttons to change a character; press ◀ or ▶ to select a character to change. When you have finished editing the input name, press **MENU**.

To restore the default input name, press ▼ repeatedly to highlight that input name in the "Restore" column. Then, press **ENTER**.

To save input names so that they can be restored after a System Reset (described on page 54), press ▼ repeatedly to highlight "Save." Then, press **ENTER**.



The ▼ button takes you from top to bottom in the left column, then from top to bottom in the right column. To highlight "Save," scroll through both columns.

Remote Control: The Remote Control menu shows you the primary and secondary infrared (IR) codes to which the VX-4000d/VX-5000d will respond. By default, both are set to 17. You can change these codes if either:

- Another device in the theater (a DVD player, for example) is responding to commands from the *standard* DHD remote control (Figure 2-6) in ways that are unpredictable or undesirable.
- You have multiple VX-4000d/VX-5000d projectors and want to control them independently, as opposed to broadcasting commands from a single remote to all of them. In this scenario, you can use multiple remotes programmed to use different IR codes. Or, you can use a single remote and change the IR code as needed to address a specific projector.

◀ **Service**

Service	
Test Video	
Input Names	
Remote Control	
Analog Out Mode	
Display Device	
HD Format	
Triggers	
Miscellaneous	
Resolution	
System Reset	
Restore Saved Settings	

Input Names	
	Restore
Composite	Composite
S-Video 1	S-Video 1
S-Video 2	S-Video 2
Component SD	Component SD
HD/RGB 1	HD/RGB 1
HD/RGB 2	HD/RGB 2
DVI 1	DVI 1
DVI 2	DVI 2
Save	



Tip

Use the DHD Controller front-panel keypad to change the projector IR code. Then, change the code sent by the remote to match as described below.

When you change a remote code on the VX-4000d/VX-5000d, you must re-program the standard DHD remote control to send that same code. To do this:

1. Using a straightened paper clip or similar object, press and hold the **CODE** button on the remote control for approximately three seconds, or until the red LED on the remote lights solid red.
2. Enter a new two-digit code between 00 and 31 inclusive. Include a leading zero for single-digit codes; for example, enter 9 as "09."
3. The LED turns off to confirm the code change. If you enter an invalid code, the LED flashes for three or four seconds. Try again, entering a valid code.

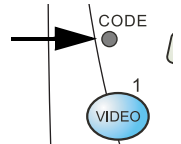

Analog Out Mode: Select Analog Out Mode from the Service menu to change the characteristics of the analog output signal from the DHD Controller. The choices are RGB-- (separate sync with negative polarity), RGB++ (separate sync with positive polarity) or RGBS (composite sync).

Display Device: The options in the Display Device menu allow you to select the projector input source, change the picture orientation, perform keystone correction and reset the lamp timer.

- **Configure:** Select Configure from the Display Device menu to access the following projector-specific functions.
- **Input Source:** Press ◀ or ▶ to select the projector input source (1 for RGBHV or 2 for DVI).



Note

If the DVI 1 or DVI 2 input is active and the input signal is HDCP-encrypted, the RGBHV output of the DHD Controller is disabled.

- **Orientation:** Change the picture orientation to suit the method of installation (Floor Front, Floor Rear, Ceiling Front or Ceiling Rear).
- **Keystone:** If the projector and screen are not installed perpendicular to each other, the image may become distorted in a trapezoidal shape, as shown in Figure 4-7. Select Keystone from the Configure menu to compensate for this.

Vertical Keystone Correction

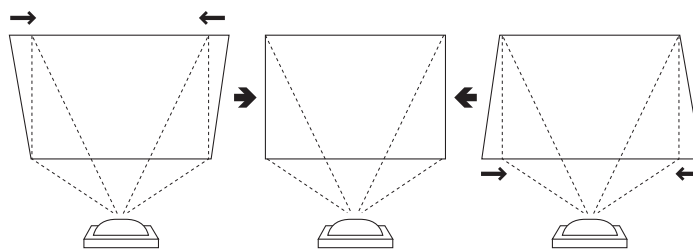

Positive values compress top;
negative values compress bottom.

Figure 4-7. Keystone Correction

- **Lamp Hours:** This menu page also displays the number of hours that the lamp has been in service, and lets you reset the counter (which is recommended after you replace the lamp; refer to **Lamp Replacement** on page 55).

HD Format: If the characteristics of the incoming signal on the HD1 or HD2 inputs are known, select HD Format from the Service menu and set them as described below. Doing so can reduce the time it takes the DHD Controller to switch from HD to 480i signals or vice versa.

This is generally not necessary unless the DHD Controller -- for whatever reason -- has difficulty determining the color space (RGB or YUV), bandwidth or resolution of the incoming HD signal. In most situations, the **Auto** settings work well.

- **HD/RGB 1 and HD/RGB 2 (Color Space):** Select Auto, RGB or YUV.
- **ADC Bandwidth:** Select Auto, 75 MHz, 150 MHz or 300 MHz.
- **YPbPr Input Resolution:** Select Auto or specify the input resolution, if known: 480i, 480p, 576i, 576p, 720p or 1080i.

Triggers: Select Triggers from the Service menu to configure the 12-volt trigger outputs. You can assign one or more trigger outputs to each aspect ratio. Those triggers are then activated by selecting that aspect ratio.

If your projector is equipped with the Runco CineWide with AutoScope system, assign at least one trigger output (the same one to which the lens motor is connected) to the Cinema and Virtualwide 2.35 aspect ratios.

To save the trigger settings so that they can be restored after a System Reset (described below), press ▼ repeatedly to highlight “Save.” Then, press **ENTER**.

HD Format	
HD/RGB 1	Auto
HD/RGB 2	Auto
ADC Bandwidth	Auto
YPbPr Input Resolution	

Miscellaneous: Select Miscellaneous from the Service menu to set the following options:

- **Language:** Select Language from the Miscellaneous menu and press the up- or down-arrows to select the OSD Language (English, French, Spanish or German).
- **Menu Mode:** This is the manner in which the OSD menus appear and disappear when you press **MENU**. Choose one of the following:

0 = No transition; menus abruptly appear and disappear.

1 = Menus fade in and out.

2 = “Checkerboard” dissolve; menus appear and disappear in sections.

3 = “Window shade” effect; menus are drawn on a diagonal from top left to bottom right, and retract in the opposite direction.

- **Timeout - Short/Long:** These settings control how long the OSD menus stay on screen. Select a time-out period of from 2 to 60 seconds.
- **Side Bar Color:** This controls the color of the inactive image area. The range is from -100 (black) to 100 (white).

The inactive image area is on either side of the active image area when using the Standard 4:3 aspect ratio (or the entire screen when no incoming video signal is present).

- **Film Mode:** Enable Film Mode to smooth out moving images from interlaced, standard-definition (SD) sources. In most cases, the VX-4000d/VX-5000d detects the proper “pull-down” rate and vertical frequency. However, if your source is jittery and/or tearing you may wish to enable Film Mode to ensure stable processing for that source.

Resolution: The DHD Controller defaults to an output resolution of 720p. When using the VX-4000d/VX-5000d with a computer or certain HD sources, you may want to force the DHD Controller to use a different output resolution. If so, select Resolution from the Service menu and choose one. Then, press **ENTER** to confirm.

System Reset: To reset ALL projector and controller settings (including image settings) back to their factory defaults, choose System Reset from the Service menu.

A confirmation message appears, reminding you to save your settings before you perform the reset, so that you can restore them afterwards. If you have done this, select Confirm to continue with the reset. Otherwise, click Back to cancel.



Caution

This action is not undoable. Proceed with caution! Before you perform a System Reset, save ALL settings, including “Custom” ISF Presets (page 48), ISF Day/Night presets (page 50), Output Shift settings (page 50), Input Names (page 51) and Trigger settings (page 53).

Restore Saved Settings: Following a System Reset, select Restore Saved Settings to apply all previously-saved settings to the projector and DHD Controller.

5. Maintenance and Troubleshooting

The lamp should be replaced when it reaches the end of its life (typically 2000 hours), or sooner if a noticeable degradation in brightness occurs. Contact your Runco dealer to obtain a replacement lamp.

5.1 Lamp Replacement

1. Turn off the projector and unplug the power cord. Allow the projector to cool down for approximately 45 minutes prior to removing the lamp assembly for replacement.
2. Using a flat-blade screwdriver, loosen the two captive Lamp Cover screws on the side of the projector and remove the cover.

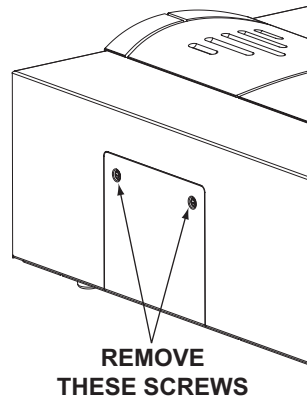

3. Remove the three Phillips round-head lamp assembly mounting screws. These are identified by arrows pointing to them on the lamp housing.
4. Grasp the lamp assembly handle and pull gently, removing the lamp module from the projector housing.
5. Install the new lamp module. Secure it in place with the three screws that you removed in Step 3.
6. Replace the lamp cover and re-tighten the two Lamp Cover screws.
7. Turn the projector on.
8. Reset the Lamp Hour counter. To do this, select Service from the Main Menu, then Display Device, then Installation. Use the cursor buttons to highlight Reset under "Lamp Hours" and press **ENTER**.

5.2 Lens Replacement

Figure 5-1 shows the VX-5000d lens assembly; the VX-4000d lens assembly is similar.

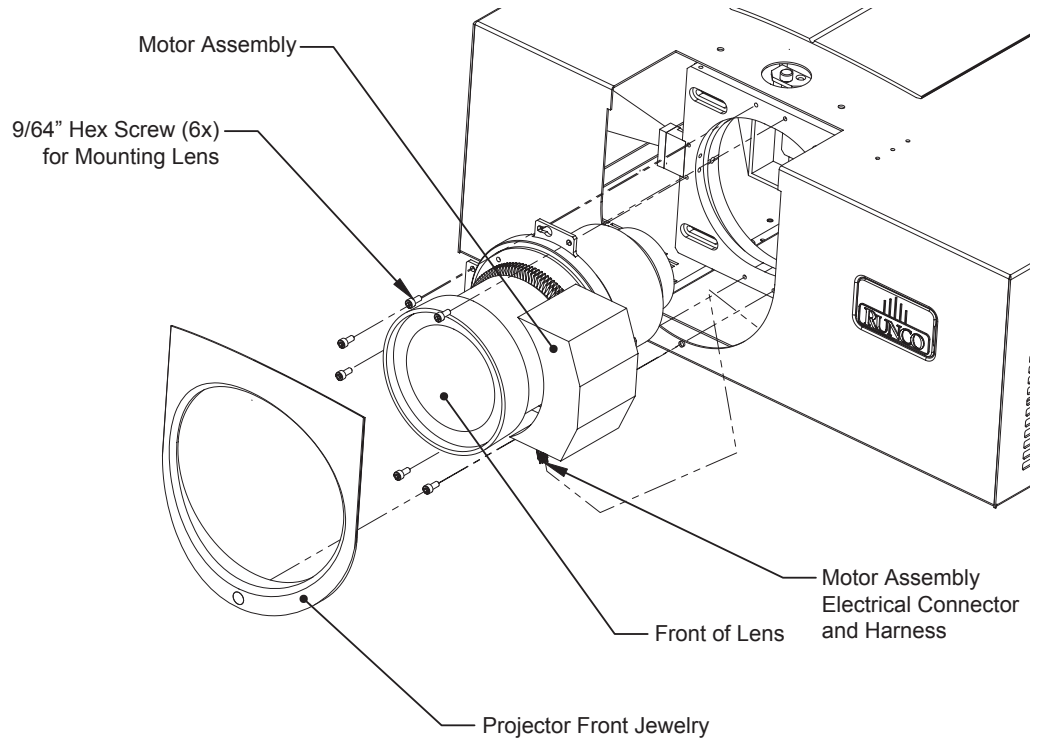

Figure 5-1. VX-5000d Lens Assembly Exploded View



Note

Lens replacement is normally performed at the Runco factory. The only time this procedure will be performed in the field is if there is a change.

Please read the Lens Replacement Procedure carefully before attempting to install a lens.

1. Remove the Projector Front Jewelry by loosening the captive #2 Phillips screw below the lens.



2. Locate and unplug the Motor Assembly Connector. Note the connector orientation for when you install the new lens.



3. Locate the six 9/64" Hex Mounting Screws (two each at 12 o'clock, 9 o'clock and 6 o'clock).
4. Remove the six Mounting Screws while supporting the Lens Assembly; Lens and Motor Assembly are now free.



5. Remove the Lens and Motor Assembly by pulling forward and to the left in order to clear the Projector chassis with the Motor Assembly.



6. **Install New Lens Assembly:** Repeat Steps 1 through 5 in reverse order.



Caution

Make sure to route the wire harness in its original position and away from the moving lens stages and Motor Assembly, to prevent unexpected disconnection or lens damage.

5.3 Troubleshooting Tips

Table 5-1 provides some general guidelines for troubleshooting problems you may encounter with the VX-4000d/VX-5000d.

If you encounter an issue not described here or in Section 3 (refer to **Installation Considerations** on page 22), or if the suggested solutions fail to resolve the problem, please contact your Runco dealer or Runco Technical Support.

Table 5-1. Troubleshooting Chart

Symptom	Possible Cause(s)	Solution
The projector does not turn on after initial installation. The power LED on the front of the DHD Controller lights red after you press the power button.	<ul style="list-style-type: none"> The VX-4000d/VX-5000d is not plugged in or the AC outlet is not active. The serial connection from the DHD Controller to the VX-4000d/VX-5000d is incorrect. The remote control batteries have run out. 	<ul style="list-style-type: none"> Ensure that the VX-4000d/VX-5000d is plugged in and that the AC outlet is active. Ensure that the RS-232 output from the DHD Controller is properly connected to the COM LINK IN port on the VX-4000d/VX-5000d (see Figure 3-7). Replace the batteries.
The projector and DHD Controller are both on, but there is no picture and on-screen menus do not appear.	<ul style="list-style-type: none"> Faulty or incorrect video connection between the DHD Controller and the VX-4000d/VX-5000d. Incorrect input source selection. Projector input source is set to RGBHV, DHD Controller input is set to DVI 1 or DVI 2 and DVI source is HDCP-encrypted. 	<ul style="list-style-type: none"> Ensure that the DVI and/or RGBHV outputs from the DHD Controller are properly connected to the video inputs on the VX-4000d/VX-5000d (see Figure 3-7). Choose the correct input source on the projector (refer to Selecting the Input Source on page 37). Set the projector input source to 2 (DVI) or use a different input on the DHD Controller for the encrypted source material.
The projector and DHD Controller are both on and menus appear on-screen, but there is no picture.	<ul style="list-style-type: none"> Incorrect source selection. Source component is not turned on. Source component is connected incorrectly or not at all. 	<ul style="list-style-type: none"> Select the correct source. Turn on the source. Check video connections to source component.
A projected image from a DVD is split or otherwise scrambled.	<ul style="list-style-type: none"> DVD player is connected to the Component input and set to progressive scan mode. 	<ul style="list-style-type: none"> Turn off progressive scan on the DVD player. Or, connect the DVD player to the HD1 or HD2 input.

Table 5-1. Troubleshooting Chart (continued)

Symptom	Possible Cause(s)	Solution
Image is too bright and/or lacks definition in the bright areas of the image.	<ul style="list-style-type: none"> • Contrast is set too high. 	<ul style="list-style-type: none"> • Lower the contrast setting.
Image appears “washed out” and/or dark areas appear too bright.	<ul style="list-style-type: none"> • Brightness is set too high. 	<ul style="list-style-type: none"> • Lower the brightness setting.
Colors in the image are swapped (for example, reds appear blue or vice versa) on one or more sources.	<ul style="list-style-type: none"> • The Red/Pr, Green/Y or Blue/Pb outputs from the source are connected to the wrong inputs on the DHD Controller. 	<ul style="list-style-type: none"> • Ensure that the source outputs are connected to the correct DHD Controller input.
Colors in the image are swapped on all sources.	<ul style="list-style-type: none"> • The Red, Green or Blue outputs from the DHD Controller are connected to the wrong inputs on the projector. 	<ul style="list-style-type: none"> • Ensure that the DHD Controller outputs are connected to the correct projector input.
The projected image is trapezoidal in shape.	<ul style="list-style-type: none"> • The projector is not perpendicular to the screen. 	<ul style="list-style-type: none"> • Adjust the projection angle or apply keystone correction (refer to Display Device on page 52).
The projector will not turn back on after it was powered down, or the image disappears during operation.	<ul style="list-style-type: none"> • The projector will not turn on for two minutes after power-down, to protect the lamp. • The lamp has failed or reached its usage limit of 2000 hours. 	<ul style="list-style-type: none"> • Wait two minutes until the LED at the front of the DHD Controller turns red. • Replace the lamp.

Notes:

6. Serial Communications

To interface the DHD Controller with a home theater automation/control system or a PC running terminal emulation software, connect it to your control system or PC as shown in Figure 3-12.

Configure the RS-232 controller or PC serial port as follows: no parity, 8 data bits, 1 stop bit and no flow control. Set the baud rate to 19200, to match that of the DHD Controller RS-232 port.

Serial commands to the DHD Controller take the following form:

- Commands are not case-sensitive.
- For a single command that takes no parameters, type the command followed by a carriage return; for example, to set the aspect ratio to Letterbox, type `LETTERBOX <Enter>`.
- For a single command that takes a parameter, type the command, a space or a comma and the desired value followed by a carriage return; for example, to set the brightness to -10, type `BRIGHTNESS -10 <Enter>` or `BRIGHTNESS,-10 <Enter>`.
- You can also send a string of multiple commands on a single line, separated by commas. For example, `COMPOSITE,BRIGHTNESS 100,ANAMORPHIC <Enter>` switches to the Composite video input, sets the brightness to 100 and sets the aspect ratio to Anamorphic. Command strings can be up to 255 characters long.

Table 6-1 lists the RS-232 command set. The “Parameter (min/max)” column shows the valid parameter ranges, or “NA” for commands that take no parameters.

When you enter a valid command, the DHD Controller executes it and acknowledges it with a plus sign on the command line (+ >). When you enter an invalid command -- one that is misspelled or followed by values outside the valid range for that command -- the DHD Controller ignores it and returns a minus sign (- >).

Table 6-1. Serial Commands

Command	Parameter (min/max)	Value Stored?	Description
Power On/Off Commands			
OFF	NA	NA	Turns projector off
ON	NA	NA	Turns projector on
POWER	0/1	NA	Turns projector on and off
POWER?	NA	NA	Returns power status

6.1 RS-232 Connection and Port Configuration

6.2 Serial Command Syntax

Table 6-1. Serial Commands (continued)

Command	Parameter (min/max)	Value Stored?	Description
Input Selection Commands			
COMPONENT	NA	YES	Selects the Component input
COMPOSITE	NA	YES	Selects the Composite video input
DVI1	NA	YES	Selects the DVI 1 input
DVI2	NA	YES	Selects the DVI 2 input
HD1	NA	YES	Selects the RGB HD 1 input
HD2	NA	YES	Selects the RGB HD 2 input
HD1PASS	NA	YES	Selects the HD PASS THRU 1 input
HD2PASS	NA	YES	Selects the HD PASS THRU 2 input
INPUT?	NA	NA	Returns active input
SVIDEO1	NA	YES	Selects the S-Video 1 input
SVIDEO2	NA	YES	Selects the S-Video 2 input
Aspect Ratio Commands			
ANAMORPHIC	NA	YES	Selects the Anamorphic aspect ratio
ASPECT?	NA	NA	Returns current aspect ratio
ASPECTIN?	NA	NA	Returns the input source aspect ratio
ASPECTOUT?	NA	NA	Returns output screen size
CINEMA	NA	YES	Selects the Cinema aspect ratio
LETTERBOX	NA	YES	Selects the Letterbox aspect ratio
STANDARD	NA	YES	Selects the Standard (4:3) aspect ratio
VIRTUALWIDE	NA	YES	Selects the VirtualWide aspect ratio
VIRTUAL235	NA	YES	Selects the Virtualwide 2.35 aspect ratio
OUT169	NA	YES	Sets the output screen to 1.78:1 (16:9)
OUT235	NA	YES	Sets the output screen to 2.35:1

Table 6-1. Serial Commands (continued)

Command	Parameter (min/max)	Value Stored?	Description
Picture Adjust Commands			
BRIGHTNESS	-100/100	YES	Sets a value for brightness
BRIGHTNESS?	NA	NA	Returns brightness setting value
CHROMADELAY	-12/12	YES	Sets a value for input color chroma delay
CHROMADELAY?	NA	NA	Returns input color chroma delay setting
COLOR	-100/100	YES	Sets a value for color
COLOR?	NA	NA	Returns color setting value
CONTRAST	-100/100	YES	Sets a value for contrast
CONTRAST?	NA	NA	Returns contrast setting value
FILMMODE?	NA	NA	Returns Film Mode setting (0 = off; 1 = on)
FILTER	0/15	YES	Sets a value for input color noise filter
FILTER?	NA	NA	Returns input color noise filter setting
PHASE	0/3	YES	Adjusts phase
PHASE?	NA	NA	Returns phase setting value
SHARPNESS	-6/6	YES	Sets a value for sharpness
SHARPNESS?	NA	NA	Returns sharpness setting value
TINT	-100/100	YES	Sets a value for tint
TINT?	NA	NA	Returns tint setting value
Image Preset Commands			
CUSTOM1	NA	YES	Loads "Custom 1" image preset
CUSTOM2	NA	YES	Loads "Custom 2" image preset
DAY	NA	YES	Loads "ISF Day" image preset
NIGHT	NA	YES	Loads "ISF Night" image preset
PRESET?	NA	NA	Returns currently-selected preset (ISF Day, ISF Night, Custom 1 or Custom 2)

Table 6-1. Serial Commands (continued)

Command	Parameter (min/max)	Value Stored?	Description
Input Position Commands			
IHEIGHT	-100/100	YES	Sets the value for input height
IHEIGHT?	NA	NA	Returns input height value
IHPOS	-100/100	YES	Sets a value for horizontal input position
IHPOS?	NA	NA	Returns input horizontal position value
IVPOS	-100/100	YES	Sets a value for vertical input position
IVPOS?	NA	NA	Returns input vertical position value
IWIDTH	-100/100	YES	Sets the value for input width
IWIDTH?	NA	NA	Returns input horizontal width value
OVERSCAN	0/10	YES	Sets the overscan percentage
OVERSCAN?	NA	NA	Returns overscan percentage
Output Shift Commands			
OHEIGHT	-100/100	YES	Sets the value for output height
OHEIGHT?	NA	NA	Returns output height value
OHPOS	-100/100	YES	Sets the value for output horizontal position
OHPOS?	NA	NA	Returns output horizontal position value
OVPOS	-100/100	YES	Sets the value for output vertical position
OVPOS?	NA	NA	Returns output vertical position value
OWIDTH	-100/100	YES	Sets the value for output width
OWIDTH?	NA	NA	Returns output horizontal width value

Table 6-1. Serial Commands (continued)

Command	Parameter (min/max)	Value Stored?	Description
Miscellaneous Commands			
BKGND	-100/100	YES	Sets the background color for 4:3 aspect ratio (-100 = black; 100 = white)
BKGND?	NA	NA	Returns background setting value
DATE?	NA	NA	Returns projector manufacture date
HDINPUTRES	NA	YES	Sets YPbPr input resolution and refresh rate for HD1/HD2, as follows: 0 = 480i 1 = 480p 2 = 576i 3 = 576p 4 = 720p / 60 Hz 5 = 1080i / 60 Hz 6 = 720p / 50 Hz 7 = 1080i / 25 Hz Any other value = Auto
HWVER?	NA	NA	Returns hardware version number
INRES?	NA	NA	Returns input resolution
LENS1	0 or 4	YES	Set primary lens configuration: 0 = No anamorphic lens present 4 = Anamorphic lens present
LENS1?	NA	NA	Returns Lens 1 configuration
LENS2	0 or 8	YES	Set anamorphic lens type: 0 = Fixed CineWide 8 = CineWide with AutoScope
LENS2?	NA	NA	Returns Lens 2 configuration
OUTRES	0/5	YES	Sets output resolution, as follows: 0 = 480i 1 = 576i 2 = 480p 3 = 576p 4 = 720p 5 = 1080i
OUTRES?	NA	NA	Returns output resolution
RGBNN	NA	NA	Sets output color space to RGB with negative horizontal and vertical sync
RGBPP	NA	NA	Sets output color space to RGB with positive horizontal and vertical sync
RGBS	NA	NA	Sets output color space to RGB with composite sync

Table 6-1. Serial Commands (continued)

Command	Parameter (min/max)	Value Stored?	Description
STATUS	NA	NA	Returns current operating status (power, input source, input resolution and input aspect ratio)
SWVER?	NA	NA	Returns software version number
TRIGGER	1/3	YES	Assigns trigger to currently-selected aspect ratio

7. Specifications

Table 7-1 lists the VX-4000d/VX-5000d specifications.

Table 7-1. VX-4000d/VX-5000d Specifications

Projector Type:	Digital Light Processing (DLP), single-chip, 16:9 SuperOnyx™ DMD
Native Resolution:	1280 x 720 (16:9)
Aspect Ratios:	Refer to Table 7-2
Video Standards:	Refer to Table 7-2
DTV Compatibility:	480p, 720p, 1080i
Scan Frequency:	Horizontal: 15 - 81 kHz Vertical: 43 - 100 Hz
Picture Size (16:9 Screen):	Recommended Width: 72 - 96 in. Maximum Width: 200 in.
Throw Distance (Factor x Screen Width):	VX-4000d: Refer to Table 3-3 VX-5000d: Refer to Table 3-4
Horizontal and Vertical Offset:	VX-4000d/Proteus A: None VX-4000d/Proteus B, C, D, E, F: Horizontal: 15% of screen width left or right Vertical: 50% of screen height up or down VX-5000d/Telesto A: None VX-5000d/Telesto B, C, D, E: Horizontal: 15% of screen width left or right Vertical: 100% of screen height up or down
Lamp:	250 Watts
Estimated Lamp Life:	2000 hours
Inputs (from DHD Controller):	(1) DVI with HDCP, (1) RGBHV, (1) RS-232

7.1 VX-4000d/VX-5000d Specifications

Table 7-1. VX-4000d/VX-5000d Specifications (continued)

<p>Brightness and Contrast (variable, depending on RVR calibration):</p>	<p>Cinema Standards Measurement System (CSMS) Specifications</p> <ul style="list-style-type: none"> - Brightness: 16.9 to 29.2 foot-Lamberts (fL) (VX-4000d); 17.2 to 29.7 foot-Lamberts (fL) (VX-5000d) - Contrast Ratio: 220:1 to 237:1 (VX-4000d); 232:1 to 255:1 (VX-5000d) <p>These measurements are taken from the projector in a controlled, home theater environment. All measurements are made to ANSI/NAPM IT7.228-1997 specifications using the Photo Research PR-650 SpectraColorimeter and Minolta LS-100 Luminance Meter, Video Essentials test DVD and a 1.3 gain, 72-inch wide screen. The projector is calibrated to a color temperature of 6,500K and has a minimum of 150 hours of usage.</p> <p>The foot-Lambert (fL) is the unit of measurement used in commercial movie theaters to express image brightness at the screen surface. The Society of Motion Picture and Television Engineers (SMPTE) specifies 16 fL as the target image brightness for film-based projectors using an open gate (without film in the projector). More importantly, today SMPTE specifies 12 fL as the target image brightness in Digital Cinema theaters. The foot-Lambert measurement is dependent on screen size, screen gain and projector light output.</p> <p>Home Theater Calibration Specifications</p> <ul style="list-style-type: none"> - Light Output: 451 to 780 ANSI Lumens (VX-4000d); 462 to 796 ANSI Lumens (VX-5000d) - Contrast Ratio: 220:1 to 237:1 (VX-4000d); 232:1 to 255:1 (VX-5000d) <p>These specifications are obtained by calibrating the projector as described above for CSMS measurements.</p> <p>Industry-Standard Specifications</p> <ul style="list-style-type: none"> - Light Output: 1600 ANSI Lumens (VX-4000d); 1700 ANSI Lumens (VX-5000d) - Contrast Ratio: 3400:1 to 4000:1 (VX-4000d); 4400:1 to 5000:1 (VX-5000d) <p>These are typical projector brightness and contrast specifications found in most companies' sales literature. Runco includes these measurements in its literature to allow for direct comparison with other manufacturers' projectors. These measurements are typically taken at 9,000K to 13,000K to get expected performance data when the projector is used in professional, commercial and industrial displays.</p>
<p>Power Requirements:</p>	<p>100 to 240 VAC (auto-sensing), 50/60 Hz, 380 Watts</p>
<p>Operating Environment:</p>	<p>40°F to 95°F (5°C to 35°C), 0% to 90% humidity (non-condensing)</p>
<p>Dimensions:</p>	<p>See Figure 7-1</p>
<p>Weight (without lens):</p>	<p>73 lbs. (33.11 kg)</p>
<p>Regulatory Approvals:</p>	<p>Complies with FCC, CE C-Tick</p>
<p>Limited Warranty:</p>	<p>Projector: Two (2) years parts and labor from the date of delivery to the end user. Lamp: 1000 hours or six (6) months, whichever comes first.</p>

Specifications are subject to change without notice.

Table 7-2 lists the DHD Controller specifications.

Table 7-2. DHD Controller Specifications

Aspect Ratios:	4:3, Letterbox, 16:9 Anamorphic, VirtualWide, Cinema, VirtualWide 2.35
Video Standards:	NTSC, PAL
Output Resolution:	720p
Inputs:	(1) Composite; (2) S-Video; (1) Component; (2) HD-R (Pr), G (Y), B (Pb), H, V; (2) DVI with HDCP
Outputs:	(1) HD/RGBHV (1) DVI-I with HDCP
Control Options:	<ul style="list-style-type: none"> - Discrete infrared remote - Serial commands via RS-232 - Front-panel controls
RS-232 Communication Parameters:	19200 bps, no parity, 8 data bits, 1 stop bit, no flow control
Trigger Outputs:	(3) +12 VDC, each rated at 750 mA and thermal fuse-protected
Bandwidth:	150 Mega Samples per Second (MSPS)
Power Requirements:	100 to 240 VAC (auto-sensing), 50/60 Hz, 160 Watts
Operating Environment:	40°F to 95°F (5°C to 35°C), 0% to 90% humidity (non-condensing)
Dimensions:	Width = 17.50 inches (444.5 mm) Depth = 11.19 inches (284.1 mm) Height = 3.75 inches (95.3 mm)
Weight:	13.0 lbs. (5.90 kg)
Regulatory Approvals:	Complies with FCC, CE C-Tick
Limited Warranty:	Two (2) years parts and labor from the date of delivery to the end user.

Specifications are subject to change without notice.

7.2 DHD Controller Specifications

7.3 VX-4000d/VX-5000d Dimensions

Figure 7-1 shows the VX-4000d/VX-5000d dimensions (all dimensions are in inches).

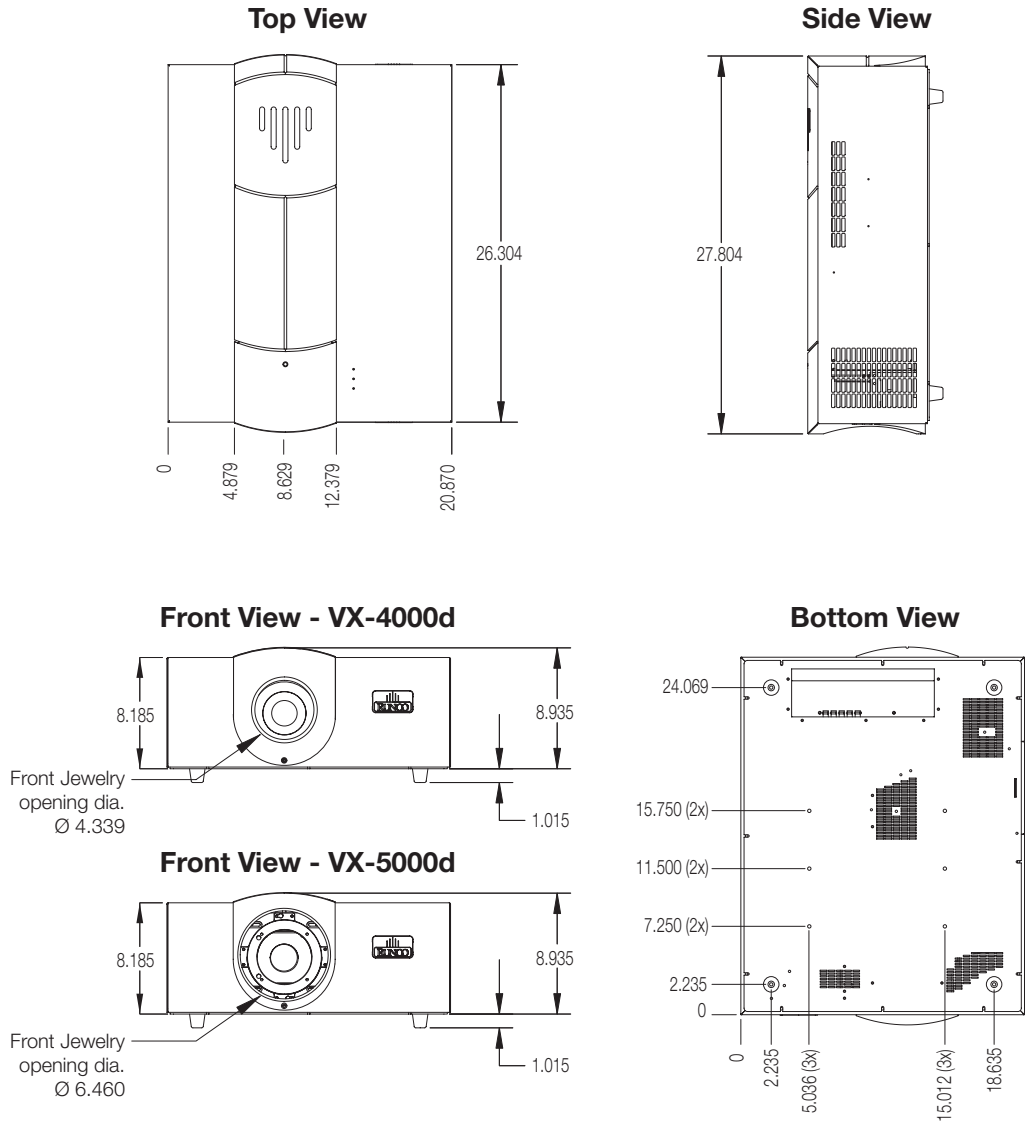

Figure 7-1. VX-4000d/VX-5000d Dimensions



SERIAL NUMBER

RUMA-010875

rev 03-17-06 v3.1

Free Manuals Download Website

<http://myh66.com>

<http://usermanuals.us>

<http://www.somanuals.com>

<http://www.4manuals.cc>

<http://www.manual-lib.com>

<http://www.404manual.com>

<http://www.luxmanual.com>

<http://aubethermostatmanual.com>

Golf course search by state

<http://golfingnear.com>

Email search by domain

<http://emailbydomain.com>

Auto manuals search

<http://auto.somanuals.com>

TV manuals search

<http://tv.somanuals.com>