



---

# INSTALLATION/OPERATION MANUAL

---



## VX-6000d



**1080p Digital Light Processing™ Projector  
and Digital High Definition (DHD™) Controller/Scaler/Processor**

VX-6000d  
VX-6000d/CineWide™  
VX-6000d/CineWide with AutoScope™



**THE WORLD'S FINEST HOME THEATER PRODUCTS™**



---

# RuncoCare™ Standard Two Year Limited Warranty

Congratulations on your purchase of a Runco® product! With proper installation, setup and care, you should enjoy many years of unparalleled video performance.

This RuncoCare Standard Limited Warranty is provided free of charge by Runco International with the purchase of a covered Runco product. The following sets forth Runco's Standard Limited Warranty applicable to all Runco projectors, processors, LCD and plasma display products, with the exception of the following models: XP-103DHD, SC-1, SC-1a and VW-100HD<sup>1</sup>.

The following terms and conditions of the RuncoCare Standard Limited Warranty represent a contract between us, Runco International and you, the customer who has purchased a Runco product. This contract applies to purchases of covered Runco products occurring on or after September 1, 2008. Runco reserves the right to change the terms of this contract, and such changes shall apply to purchases of covered Runco products that occur on or after any future effective date.

## RuncoCare Standard Features

- Two-year protection from defects in material and workmanship
- Access to 24x7 phone support
- Complimentary, second-day one-way shipping

## Warranty Coverage

Runco warrants its products to be free from defects in material and workmanship during the warranty period provided below. If, in Runco's determination, a product proves to be defective in material or workmanship during the warranty period, Runco will repair the product, replace the product with a similar new or like new product, or refund a prorata share of the purchase price (calculated based on the remainder of the warranty period and the then current MSRP<sup>2</sup> of a similar product), if repair or replacement of the product is determined by Runco to not be feasible.

## Length of Warranty

Runco products are warranted for two (2) years from the date of shipment from Runco. Lamps are warranted six (6) months from the date of shipment or 1000 hours, whichever comes first. All other accessories, which includes, but is not limited to, cables, remotes, carrying cases, lens cap and other peripherals sold with the Runco product, are warranted for ninety (90) days from the date of shipment. Repaired product or replacement lamp is subsequently warranted for the remaining portion (if any) of the original warranty term or 90 days from the date the product was shipped to you, whichever is longer.

## Eligibility

This RuncoCare Standard Limited Warranty is valid only for the first customer who purchases the covered product from an authorized Runco dealer or distributor. This warranty is not transferable. You may be required to provide proof of purchase in order to receive warranty services.

- 
1. Runco may update this list of products excluded from this warranty from time to time at Runco's sole discretion, but updates to the list of covered products will not apply on a retroactive basis.
  2. MSRP is defined as the most recent product price listed on Runco's price list.

---

## RuncoCare Claim Procedure

In the event of a product defect, please follow the warranty claim procedure provided below:

1. The Customer is required to contact a Runco dealer or Runco Technical Support via email at support@runco.com or via phone at (toll free) 800-23RUNCO (800-237-8626). If the customer is located outside North America, call +3589 4200 554 in Europe for product service.
2. Be prepared to provide the date of purchase, the place of purchase, serial number, product model number, description of the problem and troubleshooting steps already attempted.
3. Runco Technical Support staff will attempt to correct any minor issues that may be causing the problem. If Runco is unable to fix the problem to the customer's satisfaction, Runco will issue a Return Material Authorization (RMA) if it is determined that the claim was made within the coverage period of the Standard Limited Warranty.
4. The customer will need to return the defective product to the Runco repair depot location specified by the Runco technical support representative. The customer will need to properly package the defective product, consisting of the product only, and not include any accessories (e.g., cables, remotes, carrying cases, lens, lens cap and other peripherals) and return it to the Runco repair depot specified by the technical support representative. It is the customer's responsibility to properly package the hardware, include all appropriate materials, and return it to the location specified by the Runco technical support department. The customer will need to address and resolve any shipping damage claims directly with the shipping company.
5. The customer is responsible for providing a suitable box to ship the defective product to an authorized Runco repair depot. Boxes may be purchased from a Runco technical support representative.
6. The customer is responsible for paying freight charges to ship the defective product to an authorized Runco repair depot.
7. Runco will pay freight charges to return the repaired/replacement product to the customer from the Runco repair depot.
8. Once an RMA has been created, the customer may contact serviceorders@runco.com for followup questions or confirmation status of the claim process.

## Warranty Exclusions

This RuncoCare Standard Limited Warranty does not include or is limited by the following:

1. Products not purchased from an authorized Runco dealer
2. Rental costs incurred by the customer in the event of product defect or failure
3. Any product with a defaced, modified, or removed serial number
4. Damage, deterioration, or malfunction resulting from:
  - a Accident, abuse, misuse, neglect, improper ventilation, fire, water, disaster, lightning, or other acts of nature, smoke exposure (cigarette or otherwise), unauthorized product modification (including use of an unauthorized mount), or failure to follow instructions supplied with the product
  - b Repair or attempted repair by anyone not authorized by Runco
  - c Any damage to the product due to shipment
  - d Removal or installation of the product
  - e Causes external to the product, such as electric power fluctuations or failure
  - f Use of supplies or parts not meeting Runco's specifications
  - g Normal wear and tear
  - h Expected lamp degradation and normal decrease in lamp output over a period of time or as the lamp is consumed
  - i Customer caused defects, including but not limited to, scratched/defaced/altered plastics

- 
- j Failure to follow maintenance procedures as outlined in the product's user guide where a schedule is specified for regular cleaning of the product
  - k Opening the product and/or tampering with internal circuitry
  - l Products lost, stolen or discarded
  - m Any damage or dissatisfaction associated with latent images, "burnin," or any other damage determined by Runco to be the result of customer use patterns
  - n Any other cause, which does not relate to a product defect in material or workmanship
5. Removal, installation, and setup service charges are excluded from this Standard Limited warranty
  6. Runco's warranty does not cover black uniformity issues or other LCD issues associated with usage outside the Runco recommended guidelines and specifications for the product
  7. Second day shipment delivery time and availability may vary based on origin and destination and Runco is unable to deliver to PO Box and FPO Box addresses

### **Extended Service Options**

Runco offers extended and expanded service plans. For information on additional product protection, please email [serviceorders@runco.com](mailto:serviceorders@runco.com) or call (toll free) 800-23RUNCO (800-237-8626).

### **Online Product Registration**

Please visit <http://www.runco.com/info.html> to register product.

### **Limitation of Implied Warranties**

RUNCO PROVIDES NO WARRANTIES, EXPRESS OR IMPLIED, EXCEPT THOSE EXPRESSLY PROVIDED HEREIN. RUNCO EXPRESSLY DISCLAIMS ALL OTHER WARRANTIES, INCLUDING THE IMPLIED WARRANTIES OF MERCHANTABILITY AND FITNESS FOR A PARTICULAR PURPOSE.

## **Exclusion of Damages**

RUNCO'S MAXIMUM AGGREGATE LIABILITY HEREUNDER IS LIMITED TO THE COST OF REPAIR OR REPLACEMENT OF THE PRODUCT.

1. RUNCO SHALL NOT BE LIABLE FOR DAMAGE TO OTHER PROPERTY CAUSED BY ANY DEFECT IN THE PRODUCT, DAMAGES BASED UPON INCONVENIENCE, LOSS OF USE OF THE PRODUCT, LOSS OF TIME, LOSS OF PROFITS, LOSS OF BUSINESS OPPORTUNITY, LOSS OF GOODWILL, INTERFERENCE WITH BUSINESS RELATIONSHIPS, OR OTHER COMMERCIAL LOSS, EVEN IF THE CUSTOMER HAS BEEN ADVISED OF THE POSSIBILITY OF SUCH DAMAGES.
2. RUNCO SHALL NOT BE LIABLE FOR ANY CONSEQUENTIAL, INCIDENTAL, INDIRECT, SPECIAL, OR PUNITIVE DAMAGES ANY OTHER DAMAGES, WHETHER INCIDENTAL, INDIRECT, CONSEQUENTIAL OR OTHERWISE.
3. RUNCO SHALL NOT BE LIABLE FOR ANY CLAIM AGAINST THE CUSTOMER BY ANY OTHER PARTY.

## **Effect of Local Law**

This warranty gives you specific legal rights, and you may have other rights, which vary from locality to locality. Some localities do not allow limitations on implied warranties and/or do not allow the exclusion of incidental or consequential damages, so the above limitations and exclusions may not apply to you.

## **COPYRIGHT AND TRADEMARKS:**

© Copyright 2009 Runco International, LLC ("Runco"). This document contains proprietary information protected by copyright, trademark and other intellectual property laws. All rights are reserved. No part of this manual may be reproduced by any mechanical, electronic or other means, in any form, without prior written permission of Runco.

The trademarks reproduced in this Runco Owner's Manual and used on the Runco Products are either owned by Runco or are licensed by Runco. You may not reproduce or use the trademarks without the prior written consent of Runco.

THX and the THX logo are trademarks of THX Ltd. which may be registered in some jurisdictions. All rights reserved.

Runco Products are manufactured under one or more of the following patents: US. Patent 6755540 and Other Patents Pending.

# Important Safety Instructions

Thank you for your purchase of this quality Runco video product! For the best performance, please read this manual carefully as it is your guide through the menus and operation.

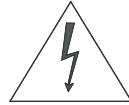
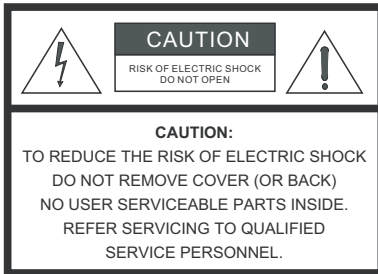

## WARNING

This symbol is intended to alert the user to the presence of uninsulated “dangerous voltage” within the product’s enclosure that may be of sufficient magnitude to constitute a risk of electric shock.



This symbol is intended to alert the user to the presence of important operating and maintenance (servicing) instructions in the literature accompanying the appliance.

1. Read these instructions.
2. Keep these instructions.
3. Heed all warnings.
4. Follow all instructions.
5. Do not use this apparatus near water.
6. Clean only with a dry cloth.
7. Do not block any of the ventilation openings. Install in accordance with the manufacturer’s instructions.
8. Do not install near any heat sources such as radiators, heat registers, stoves, or other apparatus (including amplifiers) that produce heat.
9. Do not defeat the safety purpose of the polarized or grounding type plug. A polarized plug has two blades with one wider than the other. A grounding type plug has two blades and a third grounding prong. The wide blade or the third prong is provided for your safety. When the provided plug does not fit into your outlet, consult an electrician for the replacement of the obsolete outlet.
10. Protect the power cord from being walked on or pinched particularly at plugs, convenience receptacles and the point where they exit from the apparatus.
11. Only use the attachments/accessories specified by the manufacturer.
12. Use only with a cart, stand, tripod, bracket or table specified by the manufacturer or sold with the apparatus. When a cart is used, use caution when moving the cart/apparatus to avoid injury from tip-over.
13. Unplug this apparatus during lightning storms or when unused for long periods of time.
14. Refer all servicing to qualified service personnel. Servicing is required when the apparatus has been damaged in any way, such as power supply cord or plug is damaged, liquid has been spilled or objects have fallen into the apparatus, the apparatus has been exposed to rain or moisture, does not operate normally, or has been dropped.
15. The +12V trigger only outputs 12Vdc signal for triggering. Do not connect to any other power input or output. This could cause damage to this unit.
16. Keep the packing material in case the equipment should ever need to be shipped.
17. The lamp becomes extremely hot during operation. Allow the projector to cool down for approximately 45 minutes prior to removing the lamp assembly for replacement.
18. Do not operate lamps beyond the rated lamp life. Excessive operation of lamps beyond rated life could cause them to explode in rare occasions.



---

19. Never look directly into the lens when the lamp is on.

# Compliance Information

---

## DECLARATION OF CONFORMITY:

Manufacturer's Name: Runco International, LLC

Manufacturer's Address: 1195 NW Compton Drive, Beaverton, OR 97006-1992

hereby declares that the Products' Model Numbers:

VX-6000d, VX-6000d/CineWide™ and VX-6000d/CineWide with AutoScope™

conform with the provisions of:

Council Directive 2004/108/EC on Electromagnetic Compatibility;

EN 55022 "Limits and methods of measurements of radio interference characteristics of information technology equipment" 1998;

EN 55024 "Limits and methods of measurements of immunity characteristics of information technology equipment" 1998;

Including:

- EN 61000-4-2 "Electromagnetic compatibility (EMC) Part 4: Testing and measurement techniques Section 2: Electrostatic discharge immunity test"
- EN 61000-4-3 "Electromagnetic compatibility (EMC) Part 4: Testing and measurement techniques Section 3: Radiated, Radio-Frequency, Electromagnetic Field Immunity Test"
- EN 61000-4-4 "Electromagnetic compatibility (EMC) Part 4: Testing and measurement techniques Section 4: Electrical fast transient/burst immunity test"
- EN 61000-4-5 "Electromagnetic compatibility (EMC) Part 4: Testing and measurement techniques Section 5: Surge immunity test"
- EN 61000-4-6 "Electromagnetic compatibility (EMC) Part 4: Testing and measurement techniques Section 6: Conducted disturbances induced by radio-frequency fields immunity test"
- EN 61000-4-8 "Electromagnetic compatibility (EMC) Part 4: Testing and measurement techniques Section 8: Conducted disturbances induced by power frequency magnetic fields immunity test"
- EN 61000-4-11 "Electromagnetic compatibility (EMC) Part 4: Testing and measurement techniques Section 11: Voltage dips, short interruptions and voltage variations immunity tests"

And:

- EN 61000-3-2 "Electromagnetic compatibility (EMC) Part 3, Section 2: Limits for harmonic current emissions (equipment input current up to and including 16 A per phase)" 2000;
- EN 61000-3-3 "Electromagnetic compatibility (EMC) Part 3, Section 3: Limitations of voltage changes, voltage fluctuations and flicker in public low-voltage supply systems, for equipment with rated current up to and including 16 A and not subject to conditional connection" 1995;

Council Directive 2006/95/EC and amended by M1 and C1 on Low Voltage Equipment Safety;

EN 60950 "Safety of information technology equipment, including electrical business equipment"

The Technical Construction file required by this Directive is maintained at the corporate headquarters of Runco International, LLC, located at 1195 NW Compton Drive, Beaverton, OR 97006-1992.

Date of Declaration: March 2009



## FCC PART 15:

NOTE: This equipment has been tested and found to comply with the limits for a Class B digital device, pursuant to Part 15 of the FCC Rules. These limits are designed to provide reasonable protection against harmful interference in a residential installation.

This equipment generates, uses and can radiate radio frequency energy and, if not installed and used in accordance with the instructions, may cause harmful interference to radio communications. However, there is no guarantee that interference will not occur in a particular installation. If this equipment does cause harmful interference to radio or television reception, which can be determined by turning the equipment off and on, the user is encouraged to try to correct the interference by one or more of the following measures:

- Reorient or relocate the receiving antenna.
- Increase the separation between the equipment and receiver.
- Connect the equipment into an outlet on a circuit different from that to which the receiver is connected.
- Consult the dealer or an experienced radio/TV technician for help.

## INDUSTRY CANADA (ICES-003):

This Class B digital apparatus complies with Canadian ICES-003.

Cet appareil numérique de la classe B est conforme à la norme NMB-003 du Canada.

## PRODUCT DISPOSAL:

The Product contains small amounts of tin, lead and/or mercury. Disposal of these materials may be regulated due to environmental considerations.

## IMPORTANT RECYCLE INSTRUCTIONS



Lamp(s) inside this product contain mercury. This product may contain other electronic waste that can be hazardous if not disposed of properly. Recycle or dispose in accordance with local, state, or federal Laws.

For more information, contact the Electronic Industries Alliance at [WWW.EIAE.ORG](http://WWW.EIAE.ORG).

For lamp specific disposal information check [WWW.LAMPRECYCLE.ORG](http://WWW.LAMPRECYCLE.ORG).

## DISPOSAL OF OLD ELECTRICAL AND ELECTRONIC EQUIPMENT (Applicable throughout the European Union and other European countries with separate collection programs)



This symbol found on your product or on its packaging, indicates that this product should not be treated as household waste when you wish to dispose of it. Instead, it should be handed over to an applicable collection point for the recycling of electrical and electronic equipment. By ensuring this product is disposed of correctly, you will help prevent potential negative consequences to the environment and human health, which could otherwise be caused by inappropriate disposal of this product. The recycling of materials will help to conserve natural resources. This symbol is only valid in the European Union. If you wish to discard this product, please contact your local authorities or dealer and ask for the correct method of disposal.

---

**Notes:**

# Table of Contents

<b>RuncoCare™ Standard Two Year Limited Warranty .....</b>	<b>iii</b>
<b>Important Safety Instructions .....</b>	<b>vii</b>
<b>Compliance Information .....</b>	<b>viii</b>
<b>1. Introduction .....</b>	<b>1</b>
About This Manual .....	1
Target Audience .....	1
If You Have Comments About This Manual.....	1
Textual and Graphic Conventions .....	1
Using This Manual .....	2
Description, Features and Benefits .....	3
Key Features and Benefits .....	4
Parts List .....	4
<b>2. Controls and Functions .....</b>	<b>5</b>
VX-6000d at a Glance .....	5
VX-6000d Rear Panel .....	7
DHD Controller Front Panel .....	8
DHD Controller Rear Panel .....	9
Outputs .....	9
Inputs .....	10
VX-6000d Remote Control Units .....	11
Standard DHD Remote Control.....	11
Setup Remote Control .....	14
Setup Remote Control Functions .....	15
<b>3. Installation .....</b>	<b>17</b>
Remote Control .....	17
Battery Installation .....	17
Notes on Remote Control Operation.....	18
Quick Setup .....	19

---

Installation Considerations .....	20
Installation Type.....	20
Ambient Light .....	20
Throw Distance.....	21
Vertical and Horizontal Position.....	22
Vertical and Horizontal Lens Shift.....	22
Folded Optics .....	25
Audio/Video Synchronization Issues.....	25
Other Considerations.....	26
Installing the Optional CineWide Lens Mount .....	26
Installing the AutoScope Lens Motor (VX-6000d/CineWide with AutoScope).....	27
Installing the Fixed CineWide Base Plate (VX-6000d/CineWide) .....	30
Mounting the VX-6000d .....	31
Floor Mounting (Upright) .....	31
Ceiling Mounting (Inverted).....	31
Adjusting the Projection Angle .....	31
Connections to the VX-6000d and DHD Controller .....	31
Connecting the DHD Controller to the VX-6000d .....	31
Connecting Source Components to the DHD Controller .....	33
RS-232 Controller Connection.....	38
Connecting 12-volt Trigger Outputs to External Equipment.....	39
Connecting an External IR Receiver to the DHD Controller.....	41
Connecting to AC Power .....	42
Turning on the Power .....	42
Primary Lens Adjustments .....	43
Focus .....	43
Zoom.....	43
Iris .....	43
Vertical and Horizontal Lens Shift.....	43
Adjusting the Picture Orientation .....	44
Installing and Adjusting the CineWide Anamorphic Lens .....	45
Attach Lens Mounting Assembly to Lens Motor Carriage Plate (CineWide with AutoScope) or Base Plate (fixed CineWide).....	45
Configure Lens Motor Trigger (CineWide with AutoScope).....	47
Adjust the Anamorphic Lens .....	47

---

<b>4. Operation .....</b>	<b>51</b>
Using the On-Screen Menus .....	51
Main Menu.....	52
Input Source.....	53
Aspect Ratio.....	53
Picture.....	56
Input Position.....	61
Memory Presets .....	63
Information .....	64
Calibration .....	64
Service .....	68
<b>5. Maintenance and Troubleshooting .....</b>	<b>73</b>
Lamp Replacement .....	73
Lens Replacement .....	74
Troubleshooting Tips .....	76
<b>6. External Control .....</b>	<b>79</b>
Serial Communications .....	79
RS-232 Connection and Port Configuration.....	79
Serial Command Syntax .....	79
Using Discrete IR Codes .....	84
IR Command Protocol.....	84
IR Command List.....	85
<b>7. Specifications .....</b>	<b>87</b>
VX-6000d Specifications .....	87
DHD Controller Specifications .....	89
VX-6000d Dimensions .....	90
Supported Timings .....	91

**Notes:**

# List of Figures

2-1. VX-6000d Front/Top/Side/Bottom/Rear View .....	5
2-2. VX-6000d Rear Panel .....	7
2-3. DHD Controller Front Panel .....	8
2-4. DHD Controller Rear Panel .....	9
2-5. Standard DHD Remote Control .....	11
2-6. TheaterMaster Remote Control for VX-6000d.....	14
3-1. Available Range of the Remote Control .....	18
3-2. Estimating Throw Distance .....	21
3-3. Projector Placement .....	22
3-4. Vertical Lens Shift (Example Only).....	22
3-5. Horizontal Lens Shift (Example Only).....	23
3-6. Folded Optics.....	25
3-7. VX-6000d/CineWide with AutoScope Motor Assembly – Exploded View .....	27
3-8. VX-6000d with Ceiling Mount Adapters/Projector Stands .....	28
3-9. AutoScope Lens Motor Installation .....	29
3-10. Connecting the VX-6000d to the DHD Controller .....	32
3-11. HDMI Source Connections .....	33
3-12. Component Video Source Connections.....	34
3-13. RGBHV Source Connections.....	35
3-14. SCART RGBS Source Connections.....	36
3-15. S-Video and Composite Video Source Connections .....	37
3-16. RS-232 Control System Connection.....	38
3-17. 12-volt Trigger Output Connections (from DHD Controller) .....	39
3-18. 12-volt Trigger Output Connection (from Projector).....	40
3-19. External IR Receiver Connection.....	41
3-20. Vertical and Horizontal Lens Shift Adjustments .....	44
3-21. VX-6000d Anamorphic Lens Mounting Assembly - Exploded View.....	45
3-22. Attaching the Anamorphic Lens to the Lens Adapter Ring .....	46
4-1. VX-6000d OSD Menu Structure .....	51
4-2. Typical PLUGE Pattern for Adjusting Brightness .....	56
4-3. Typical Gray Bar Pattern for Adjusting Contrast .....	57
4-4. Typical Color Bar Pattern for Adjusting Color Saturation and Tint.....	58

4-5. Typical Test Pattern for Adjusting Sharpness .....	60
4-6. Overscan Modes .....	62
4-7. CIE 1931 Chromaticity Diagram .....	65
5-1. VX-6000d Lens Assembly Exploded View .....	74
6-1. RC5 Message Format .....	85
7-1. VX-6000d/CineWide Dimensions (with Optional Ceiling Mount).....	90



# 1. Introduction

---

This Owner's Manual describes how to install, set up and operate the Runco Video Extreme™ VX-6000d DLP™ Projector and DHD Controller. Throughout this manual, the Runco VX-6000d DLP Projector and DHD Controller/Scaler/Processor are referred to collectively as the "VX-6000d."

Runco has prepared this manual to help home theater installers and end users get the most out of the VX-6000d.

Runco has made every effort to ensure that this manual is accurate as of the date it was printed. However, because of ongoing product improvements and customer feedback, it may require updating from time to time. You can always find the latest version of this and other Runco product manuals on-line, at [www.runco.com](http://www.runco.com).

Runco welcomes your comments about this manual. Send them to [techpub@runco.com](mailto:techpub@runco.com).

**Text Conventions:** The following conventions are used in this manual, in order to clarify the information and instructions provided:

- Remote and built-in keypad button identifiers are set in upper-case bold type; for example, "Press **EXIT** to return to the previous menu."
- Computer input (commands you type) and output (responses that appear on-screen) is shown in monospace (fixed-width) type; for example: "To change the aspect ratio to Letterbox, type LETTERBOX **<Enter>**."
- All keys with functional names are initial-capped, set in bold type and enclosed in angle brackets. These keys are the following: **<Enter>**, **<Spacebar>**, **<Control>**, **<Esc>** and **<Tab>**.
- **<Enter>** indicates that you may press either the RETURN or ENTER key on your keyboard if it has both keys.

In addition to these conventions, underlining, boldface and/or italics are occasionally used to highlight important information, as in this example:



*A carriage return **must** be used after each command or string.*

---

## 1.1 About This Manual

### ◀ Target Audience

### ◀ If You Have Comments About This Manual...

### ◀ Textual and Graphic Conventions

**Graphic Conventions:** These symbols appear in numerous places throughout the manual, to emphasize points that you must keep in mind to avoid problems with your equipment or injury:



**Tip**

*TIPS highlight time-saving short cuts and helpful guidelines for using certain features.*



**Note**

*NOTES emphasize text with unusual importance or special significance. They also provide supplemental information.*



**Caution**

*CAUTIONS alert users that a given action or omitted action can degrade performance or cause a malfunction.*



**WARNING**

*WARNINGS appear when a given action or omitted action can result in damage to the equipment, or possible non-fatal injury to the user.*



**DANGER!**

*DANGER appears when a given action can cause severe injury or death.*

## 1.2 Using This Manual

Use the following table to locate the specific information you need in this manual.

<b>If you need...</b>	<b>... Turn to page:</b>
Information about obtaining service	iv
General information about the VX-6000d DLP Projector and DHD Controller/Scaler/Processor	3
Installation instructions	17
First-time configuration instructions	44
Advanced configuration instructions	64
Troubleshooting tips	76
Product specifications	87

The Runco Video Extreme™ VX-6000d follows in the footsteps of its renowned predecessor, the VX-5000d by offering extraordinary performance, state of the art optics, impressive custom installation flexibility and today's most advanced DLP technology with 1920 x 1080 SuperOnyx™ resolution.

Its performance is so extraordinary, in fact, that the VX-6000d has earned its place in our exclusive, Video Xtreme™ family of products — our top of the line and the world's first video products to earn prestigious THX® certification.

The VX-6000d incorporates Runco's exclusive Enhanced GEN 3™ engineering advancements to make more efficient use of optical light engine design. This results in greater light output and dramatically increases contrast ratio.

Among the advances Runco has developed are a sophisticated color balancing system and Reflectance Volume Regulation™ (RVR™), which provides the perfect balance of black and white levels. These engineering achievements are combined with lens choices featuring world-class optics and lens shift versatility. The resulting images are superb. In fact, the VX-6000d can easily surpass the black levels of film projectors!

The VX-6000d is supplied with Runco's next-generation, Digital High Definition (DHD™) Controller/Scaler/Processor, featuring advanced Vivix III™ video processing and superb scaling. In addition, Runco's multiple aspect ratio control includes its unique VirtualWide™ mode for viewing standard video formats in widescreen without loss of image quality. The DHD provides for a pure digital signal path from input to light engine.

The VX-6000d produces an impressive 1750 ANSI lumens of light output (CSMS light output of 17.3 to 29.8 ft-Lamberts).

For uncompromising widescreen reproduction of movies originally filmed in the "scope" (2.35:1) format, the VX-6000d can be equipped with Runco's patent-pending CineWide™ technology, a combination of software, electronics and high-quality anamorphic optics. CineWide maintains constant vertical height on the screen just as in a movie theater. When a viewer transitions from 1.78:1 (16:9) program material to 2.35:1, the image simply gets wider while full height is maintained. Also available with the VX-6000d is CineWide with AutoScope™, an enhanced, remote-controlled motorized version of CineWide.

**Note**

*CineWide requires the use of a 2.35:1 or similar aspect ratio superwide format screen.*

Discrete IR and RS-232 control make custom installation seamless, while discrete source and aspect ratio selection accommodate any automation control system.

---

## 1.3 Description, Features and Benefits

- Key Features and Benefits** ➤ The VX-6000d offers these key features and benefits:
- Runco-engineered, Enhanced GEN 3 Technology™ with RVR
  - Native Resolution: 1920 x 1080 (16:9 Native Aspect Ratio)
  - Two HDMI Inputs (on DHD Controller) with High-bandwidth Digital Content Protection (HDCP)
  - HDTV Compatible
  - CinOptx™ *Telesco* lens options for stunning sharpness and throw distance flexibility

- Parts List** ➤ Your VX-6000d is shipped with the following items. If any items are missing or damaged, please contact your Runco dealer or Runco Customer Service at (800) 23-RUNCO.
- VX-6000d DLP Projector and DHD Controller/Scaler/Processor
  - Setup Remote Control Unit and four (4), AAA-size batteries (for adjusting lens zoom and focus)
  - DHD Controller Remote Control Unit and two (2), AAA-size batteries
  - AC Power Cords (2)
  - RJ-11 Telephone Cable, 50 feet (15.24 meters)
  - 3/16" Hex Wrench (for adjusting lens position)
  - Rack-mount hardware for the DHD Controller
  - Runco VX-6000d Installation/Operation Manual (this document)
  - VX-6000d Quick Setup Guide

**Optional Accessories:**

- CineWide™ technology (fixed, secondary anamorphic lens)
- CineWide™ with AutoScope™ system (secondary anamorphic lens and motorized mount)
- Ceiling mount kit (part number 956-0074-00)

# 2. Controls and Functions

Figure 2-1 shows the key VX-6000d components.

## 2.1 VX-6000d at a Glance

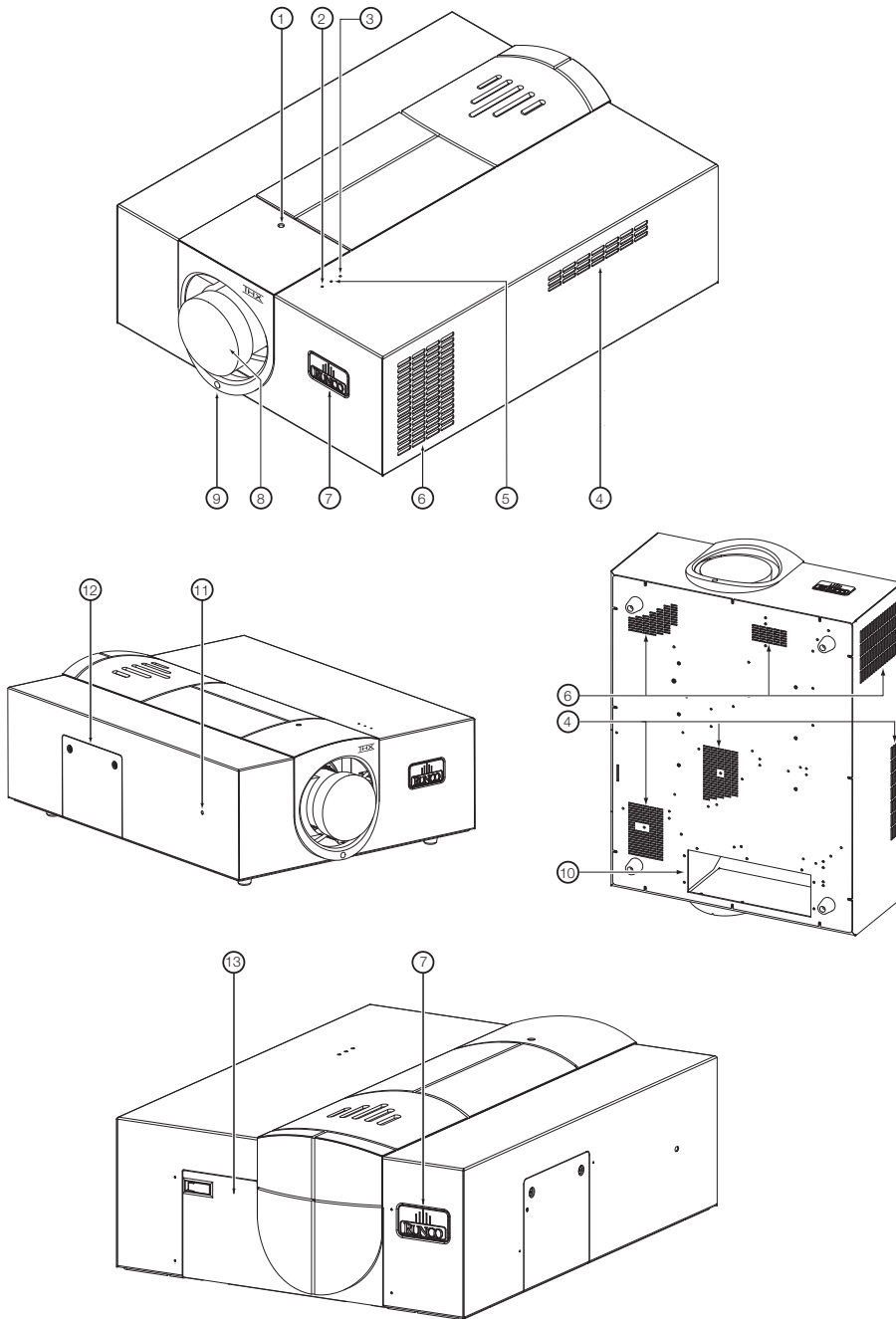

**Figure 2-1. VX-6000d Front/Top/Side/Bottom/Rear View**

1. **VERTICAL LENS SHIFT**  
Using a 3/16" hex wrench, turn this to move the lens up or down.
2. **POWER LED**  
Lights red to indicate that the projector is in standby; lights blue to indicate normal operation.
3. **TEMP LED**  
Lights red to indicate that the projector has overheated and shut down.
4. **INTAKE VENTS**  
Cool air enters the projector through these vents. To prevent overheating, ensure that these vents are never blocked.
5. **LAMP LED**  
Lights blue to indicate normal lamp operation; off when the lamp has failed or the projector is off.
6. **EXHAUST VENTS**  
Hot air exits the projector through these vents. This air can be quite hot. Ensure that there are no heat-sensitive objects near them and that they are never blocked.
7. **RUNCO LOGO / LENS CONTROL INFRARED (IR) RECEIVER**  
During initial installation, rotate the logo plate one quarter-turn (90 degrees) to uncover the lens control IR receiver. This enables you to use the motorized focus and zoom (image size) controls.

When you have finished adjusting the zoom and focus, you can rotate the logo to match the projector orientation: inverted (ceiling-mounted) or upright. To rotate the logo, grip it at the sides, pull it away from the projector and turn it.

8. **PRIMARY PROJECTION LENS**
9. **JEWELRY RETAINING SCREW**  
Loosen this screw to remove the front jewelry, should you ever need to replace the lens.
10. **CABLE OPENING**  
Pass cables through this opening.
11. **HORIZONTAL LENS SHIFT**  
Using a 3/16" hex wrench, turn this to move the lens left or right.
12. **LAMP COVER**  
Remove this cover to access the lamp compartment.
13. **REAR PANEL ACCESS DOOR**  
Open this door to access the rear-panel connectors and built-in keypad. To open the door, push on the left side of the lever and rotate it 90 degrees clockwise. Then, pull the lever toward you and down slightly.

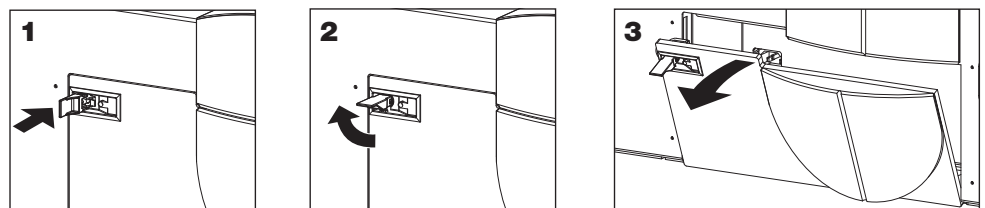
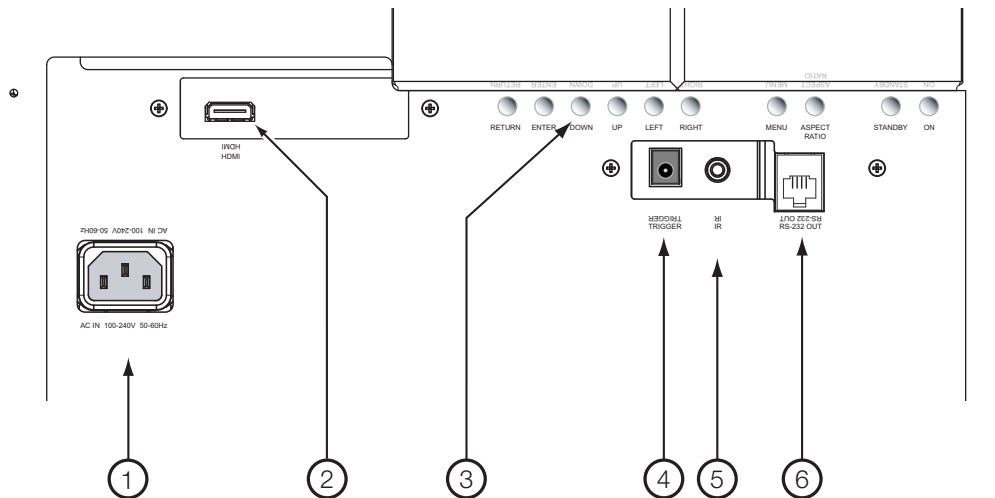

Figure 2-2 shows the VX-6000d rear connector panel.

## 2.2 VX-6000d Rear Panel

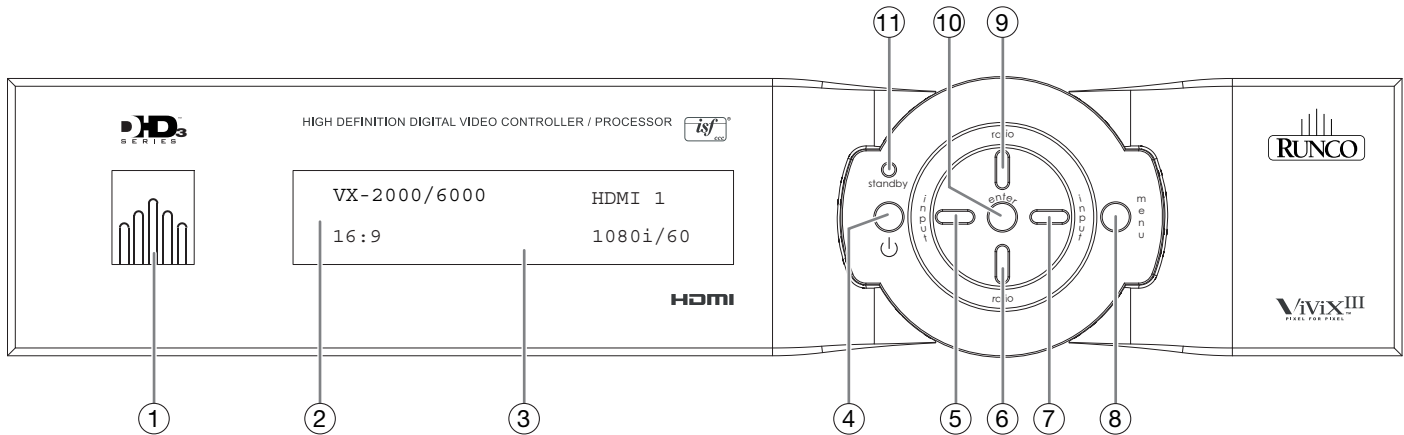

**Figure 2-2. VX-6000d Rear Panel**

1. **POWER INPUT (100 to 240 VAC)**  
Connect the VX-6000d to power here.
2. **HDMI INPUT**  
An HDCP-compliant, digital video input for connecting the HDMI output from the DHD Controller.
3. **BUILT-IN KEYPAD**  
Used for maintenance and troubleshooting purposes only.
4. **12-VOLT (200 mA) TRIGGER OUTPUT (cylindrical, DC power supply-type jack)**  
Connection for a retractable screen, screen masking or other, 12-volt trigger-activated equipment. Outputs +12 volts/200 mA when the projector is turned on.
5. **WIRED IR (3.5-mm, mini phono jack)**  
Not used. To use an external infrared receiver or wired remote control with this projector, connect it to the IR input on the DHD Controller (see Figure 2-4).
6. **RS-232C (RJ-11 female connector)**  
Connect the **Display Control** (RS-232) output from the DHD Controller here, using the provided communication cable.

## 2.3 DHD Controller Front Panel

Figure 2-3 shows the controls and indicators on the DHD Controller front panel; the paragraphs that follow describe them.



**Figure 2-3. DHD Controller Front Panel**

1. **RUNCO ICON**  
Lights blue to indicate that the controller is on or powering up.
2. **IR SENSOR**  
Receives IR commands from the remote control.
3. **VACUUM FLUORESCENT DISPLAY**  
Can be used instead of the On-Screen Display (OSD). Displays currently-selected menu or – if no menu is selected – the connected display device model, current source, input resolution and aspect ratio.
4. **ON/STANDBY BUTTON**  
Press once to toggle from standby mode to on mode. Press it again to return to standby mode. For a discrete on or off command, you can use the direct access buttons on the remote control.
5. **LEFT BUTTON**  
Used to direct-select inputs or move the menu cursor left in the OSD. When no menu is present on-screen, the **LEFT** button toggles through the different sources, in this order:  
HDMI 2 - HDMI 1 - SCART - HD 2 - HD 1 - Component - S-Video 2 - S-Video 1 - Composite Video
6. **DOWN BUTTON**  
Use to direct-select aspect ratios or move the menu cursor down in the OSD. When no menu is present on-screen, this button toggles through the different aspect ratios, in this order:  
16:9 - 4:3 - Letterbox - VirtualWide - Cinema - Virtual Cinema - Native



7. **RIGHT BUTTON**

Used to direct-select inputs or move the menu cursor right in the OSD. When no menus are present on-screen, the **RIGHT** button toggles through the different sources, in this order:  
 Composite Video - S-Video 1 - S-Video 2 - Component - HD 1 - HD 2 - SCART - HDMI 1 - HDMI 2

8. **MENU BUTTON**

Press the **MENU** button to bring up the main menu, or to exit the current menu and return to the previous one.

9. **UP BUTTON**

Use to direct-select aspect ratios or move the menu cursor up in the OSD. When no menus are present on-screen, the **UP** button toggles through aspect ratios in the following order:  
 Native - Virtual Cinema - Cinema - VirtualWide - Letterbox - 4:3 - 16:9

10. **ENTER BUTTON**

When an item is highlighted on the OSD, the **ENTER** button selects the item.

11. **STANDBY LED**

Lights amber when the DHD Controller is in standby mode; otherwise it is off.

Figure 2-4 shows the rear connector panel on the DHD Controller.

**2.4  
DHD Controller Rear  
Panel**

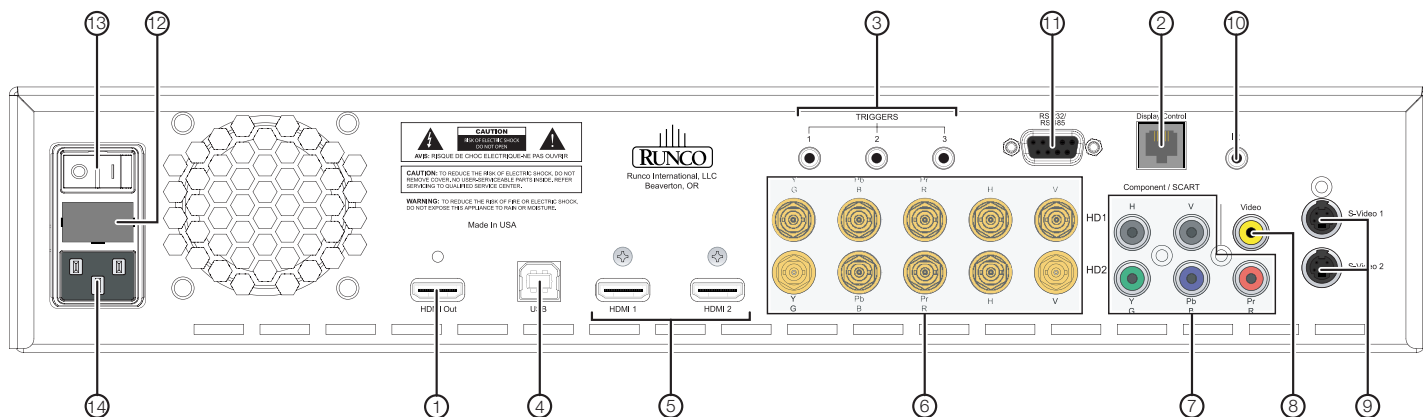

**Figure 2-4. DHD Controller Rear Panel**

1. **HDMI Out**

Connect this to the **HDMI** connector on the VX-6000d (see Figure 2-2).

2. **Display Control**

Connect this to the **RS-232** port on the VX-6000d, using the provided communication cable.

3. **TRIGGERS**

Connection for up to three (3), 12-volt trigger-controlled devices. Output current is limited to 250 milliamperes (mA).

◀ **Outputs**

- Inputs** ➤
4. **USB**  
A standard, USB Series “B” connection to a personal computer. (For future use.)
  5. **HDMI 1 / HDMI 2 (Digital)**  
HDCP-compliant digital video inputs for connecting an HDMI or DVI source.
  6. **HD1 / HD2 (5 x Analog BNCs)**  
Two inputs (five BNCs per input) for connecting standard-definition (SD = 480i/576i), enhanced-definition (ED = 480p/576p) or high-definition (HD = 720p/1080i/1080p) component video sources, or RGBHV sources such as personal computers.
  7. **Component / SCART (5 x RCA connectors)**  
SD/HD input for connecting SDTV, EDTV or HDTV component video sources, or RGBHV sources. Also provides RGB input for SCART RGBS sources.
  8. **Video**  
Standard, composite video input for connecting a VCR, camcorder or other composite video source. Also provides composite sync input for SCART RGBS sources.
  9. **S-Video 1 / S-Video 2**  
Two, standard S-Video inputs for connecting a DVD player, satellite receiver or Super VHS (S-VHS) VCR.
  10. **IR**  
Wired input from a Niles- or Xantech-compatible, infrared (IR) repeater system. It is a 3.5-mm, mini phono jack, wired as follows:  
Ring = No connection  
Tip = IR Input  
Sleeve = Ground
  11. **RS-232 / RS-485**  
A female, 9-pin D-sub connector for interfacing with a PC or automation/control system. (Currently, only RS-232 interface is supported.)
  12. **MAIN AC FUSE**  
This is the main AC input fuse (5mm x 20mm, 500 mA, 250V slow-blow).
  13. **MAIN POWER SWITCH**  
Disconnects or applies power to the DHD Controller.
  14. **POWER INPUT (100 to 240 VAC)**  
Connect the DHD Controller to power here.

The VX-6000d ships with two remote control units:

- A standard Runco DHD Controller remote control unit; and
- A universal, “setup” remote control unit that can be used with other home theater equipment.

**Only the setup remote control can be used to perform zoom and focus adjustments.** For this reason, you must use it to complete the initial VX-6000d installation and setup. After you have completed the installation, only the standard DHD Controller remote control is needed to access all projector and controller functions.

Figure 2-5 shows the standard DHD remote control, and the paragraphs that follow describe its functionality.

## 2.5 VX-6000d Remote Control Units

### ◀ Standard DHD Remote Control

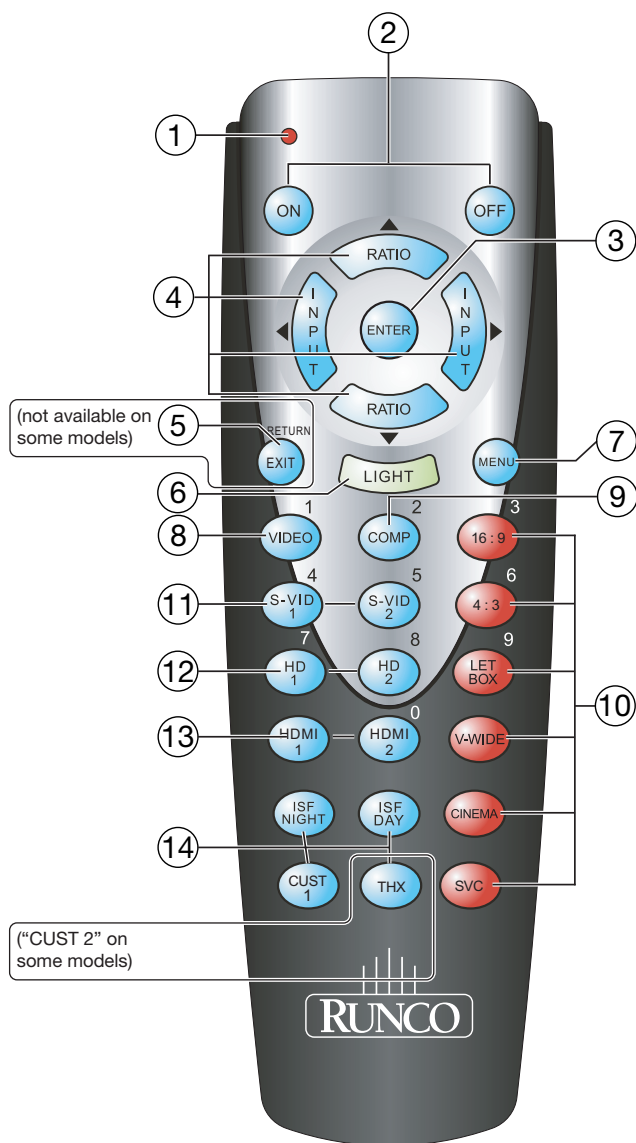

**Figure 2-5. Standard DHD Remote Control**

1. **IR OUTPUT INDICATOR**  
Lights when a button is pressed to indicate that an IR signal is being transmitted.
2. **ON / OFF**  
Press to turn the display on or off.
3. **ENTER**  
Press to select a highlighted menu item or confirm a changed setting.
4. **Cursor Buttons (▲, ◀, ▼, ▶)**  
Use these buttons to select items or settings, adjust settings or switch display patterns.

When no menu is present on-screen, the **UP** and **DOWN** buttons toggle through the available aspect ratios, in this order:

**UP** Button = Native - Virtual Cinema - Cinema - VirtualWide - Letterbox - 4:3 - 16:9

**DOWN** Button = 16:9 - 4:3 - Letterbox - VirtualWide - Cinema - Virtual Cinema - Native

Likewise, the **LEFT** and **RIGHT** buttons toggle through the different source inputs, in this order:

**LEFT** Button = HDMI 2 - HDMI 1 - SCART - HD 2 - HD 1 - Component - S-Video 2 - S-Video 1 - Composite Video

**RIGHT** Button = Composite Video - S-Video 1 - S-Video 2 - Component - HD 1 - HD 2 - SCART - HDMI 1 - HDMI 2

5. **RETURN / EXIT**  
Press this button to exit the current menu and return to the previous one.



**Note**

*Not all remote control units have this button. If yours does not, use the **MENU** button (see below) to exit the current menu.*

6. **LIGHT**  
Press to illuminate the buttons.
7. **MENU**  
Press this button to access the OSD controls, or to exit the current menu and return to the previous one.
8. **VIDEO (1)**  
Press to select Composite video input as the source or to enter the numeric character "1."
9. **COMP (Component) (2)**  
Press to select Component/SCART video input as the source or to enter the numeric character "2."

---

**10. Aspect Ratio Selection Buttons**

Use the red buttons to select an aspect ratio directly or to enter numeric characters, as follows:

**16:9 (3)**

For viewing 16:9 DVDs or HDTV programs in their native aspect ratio.

**4:3 (6)**

Scales the input signal to fit 4:3 display mode in the center of the screen.

**LETBOX (Letterbox) (9)**

For viewing LaserDisc movies or non-anamorphic DVDs on a 16:9 screen.

**V-WIDE (VirtualWide)**

Enlarges a 4:3 image horizontally in a NON-linear fashion to fit 16:9 full screen display.

**CINEMA**

For viewing 2.35:1 source material. The upper and lower portions are masked.

**SVC**

Selects the Virtual Cinema aspect ratio.

**11. S-VID 1 (4) / S-VID 2 (5) (S-Video)**

Press to select an S-Video input or to enter the numeric character "4" or "5."

**12. HD 1 (7) / HD 2 (8)**

Press to select a HD (RGBHV or YPbPr component) input or to enter the numeric character "7" or "8."

**13. HDMI 1 / HDMI 2 (0)**

Press to select a Digital Video input. Press **HDMI 2** to enter the numeric character "0."

**14. Memory Preset Buttons:****ISF NIGHT**

Press to recall settings for the current input from the "ISF Night" memory preset.

**ISF DAY**

Press to recall settings for the current input from the "ISF Day" memory preset.

**CUST 1**

Press to recall settings for the current input from the "Custom" memory preset.

**THX (CUST 2)**

Press to recall settings for the current input from the "THX" memory preset.

**Setup Remote Control** ➤ The setup remote control unit furnished with the VX-6000d gives you access to the motorized lens controls (focus and zoom) and can be programmed to control other, non-Runco home theater components. (For detailed programming instructions, refer to the manual provided with the remote control.)

Figure 2-6 shows the setup remote control, and the paragraphs that follow describe its functionality.

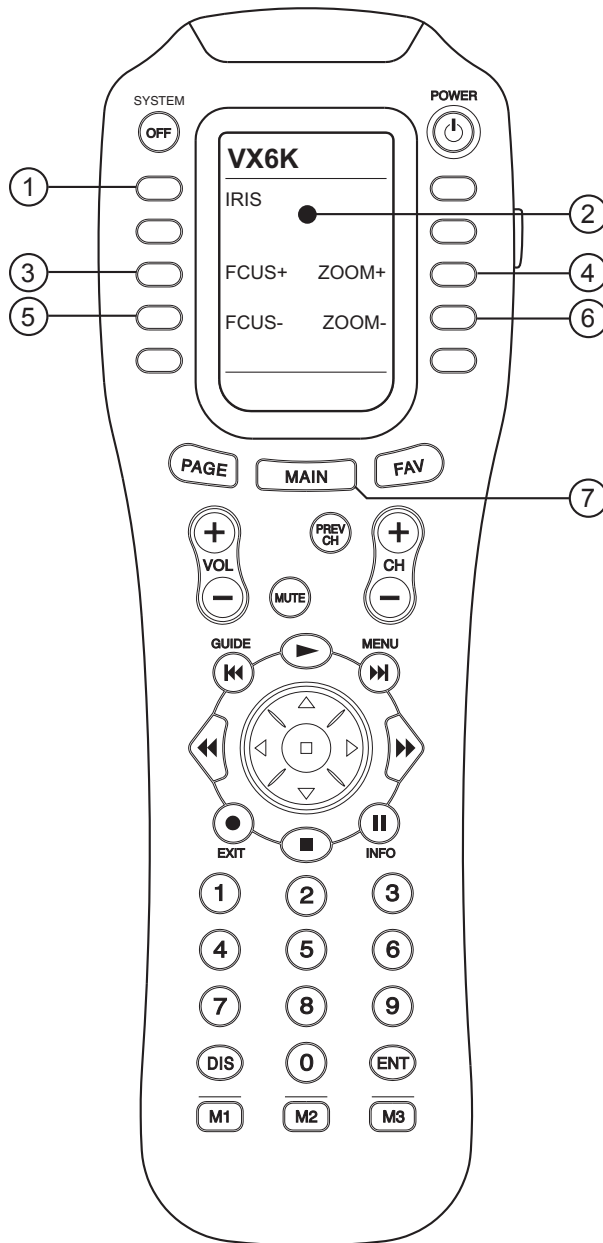

**Figure 2-6. TheaterMaster Remote Control for VX-6000d**

- 
1. **IRIS Button**  
Press repeatedly to change the iris size (small or large).
  2. **Liquid Crystal Display**  
Displays currently-selected LCD Menu page.
  3. **FCUS+ Button**  
Press and hold to adjust the focus.
  4. **ZOOM+ Button**  
Press and hold to zoom in (enlarge the image).
  5. **FCUS- Button**  
Press and hold to adjust the focus.
  6. **ZOOM- Button**  
Press and hold to zoom out (make the image smaller).
  7. **MAIN Button**  
Displays the Main LCD Menu page.

◀ **Setup Remote Control  
Functions**

**Notes:**



# 3. Installation

## 3.1 Remote Control

### ◀ Battery Installation

To install batteries in the remote control:

1. Remove the battery cover from the back of the remote control.
2. Insert the batteries included with the remote control. Ensure that the polarities correctly match the ⊕ and ⊖ markings inside the battery compartment.
3. Replace the battery cover.

**Setup Remote**

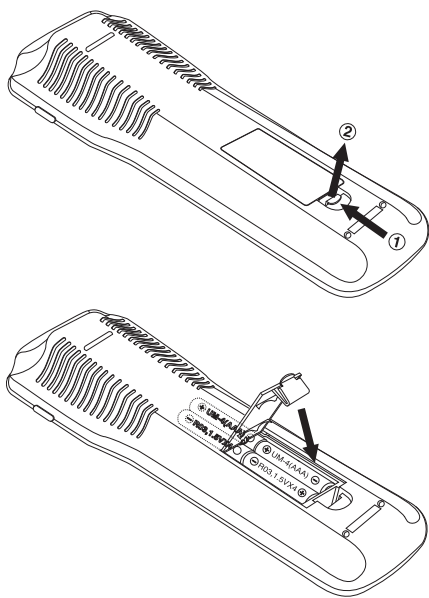

**Standard DHD Remote**

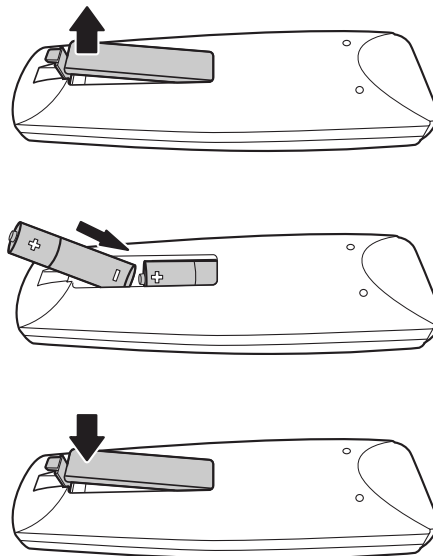

**Note**

1. Do not mix an old battery with a new one or different types of batteries.
2. If you will not use the remote control for a long time, remove the batteries to avoid damage from battery leakage.

**Notes on Remote Control Operation** ➤

The remote control can be used to control the VX-6000d within the ranges shown in Figure 3-1.

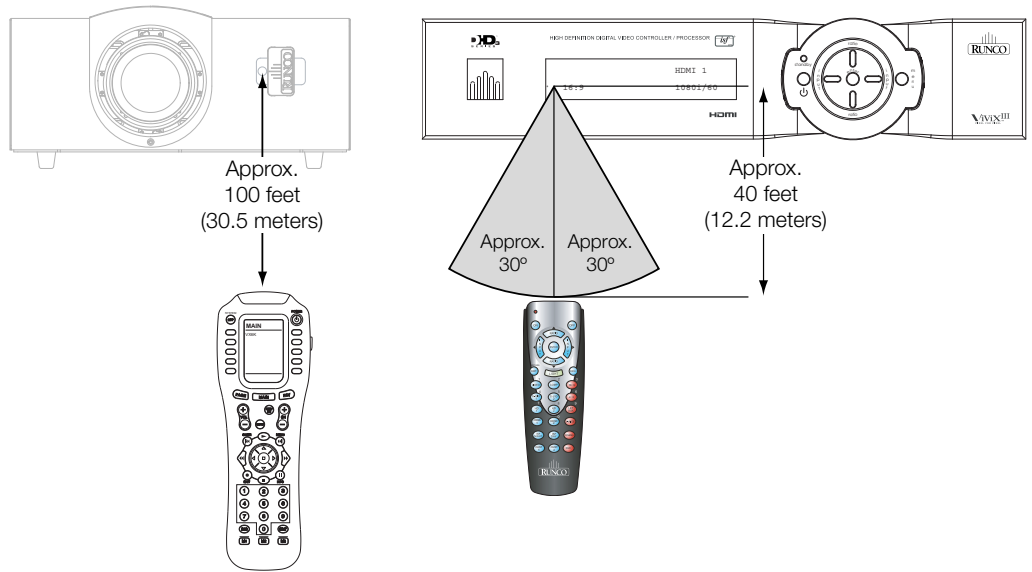

**Figure 3-1. Available Range of the Remote Control**

- Do not drop the remote control or expose it to moisture or high temperature.
- The remote control may malfunction under a fluorescent lamp. If that occurs, move the DHD Controller away from the fluorescent lamp.
- Make sure that there is nothing obstructing the infrared beam between the remote control and the IR receiver on the DHD Controller or projector.



**Note**

*The signal from the remote control can be reflected by walls or other surfaces.*

- If the effective range of the remote control decreases, or it stops working, replace the batteries with new ones.
- Ambient conditions may possibly impede the operation of the remote control. If this happens, point the remote control at the DHD Controller or projector and repeat the operation.

Table 3-1 gives a quick overview of the VX-6000d installation process. The sections following this one provide detailed instructions.

**Note**

*Installation should be performed by a qualified custom video installation specialist.*

## 3.2 Quick Setup

**Table 3-1. Installation Overview**

Step	Procedure	For Details, Refer to page...
1	Choose a location for the projector	20
2	<b>If installing a VX-6000d/CineWide or VX-6000d/CineWide with AutoScope:</b> Install AutoScope lens motor or fixed CineWide base plate	26
3	Mount the projector	31
4	Connect the DHD Controller to the projector	31
5	Connect signal sources to the DHD Controller	33
6	Connect external controller to RS-232 port (optional)	38
7	Connect 12-volt trigger outputs to AutoScope lens motor and/or other equipment (optional)	39
8	Connect projector, DHD Controller and lens motor (if present) to AC power and power up	42
9	Primary Lens adjustments: projected image size (zoom), position (shift) and focus	22, 43
10	For rear-screen and/or ceiling-mount installations, select the proper picture orientation	44
11	Install CineWide anamorphic lens (optional)	45
12	CineWide lens adjustments: position, pitch (angle), geometry and focus	47
13	Projector calibration: adjust the following <b>for each input</b> ; save settings when finished: <ul style="list-style-type: none"> <li>• Aspect ratio</li> <li>• Brightness</li> <li>• Contrast</li> <li>• Color level</li> <li>• Tint</li> <li>• Input position</li> </ul>	53 through 67

### 3.3 Installation Considerations

Proper installation of your projector will ensure the quality of your display. Whether you are installing a projector temporarily or permanently, you should take the following into account to ensure your projector performs optimally.

**Installation Type** ➤ Choose the installation type that best suits your needs: front or rear screen, floor mount or inverted mount. Table 3-2 compares these various installation methods.

**Table 3-2. Projector Installation Options**

Advantages	Considerations
<b>Front Screen, Floor Mount Installation</b>	
<ul style="list-style-type: none"> <li>• Easy to set up</li> <li>• Can be moved or changed quickly</li> <li>• Easy to access</li> </ul>	<ul style="list-style-type: none"> <li>• Shares floor space with audience</li> </ul>
<b>Front Screen, Inverted Mount (ceiling) Installation</b>	
<ul style="list-style-type: none"> <li>• Does not take up audience space</li> <li>• Projector is unobtrusive</li> <li>• Projector cannot be accidentally moved</li> </ul>	<ul style="list-style-type: none"> <li>• Installation is more permanent</li> <li>• Projector access is more difficult</li> </ul>
<b>Rear Screen, Floor Mount Installation</b>	
<ul style="list-style-type: none"> <li>• Projector is completely hidden</li> <li>• Projector is easily accessed</li> <li>• Usually good ambient light rejection</li> </ul>	<ul style="list-style-type: none"> <li>• Requires separate room</li> <li>• Installation cost is usually higher</li> </ul>
<b>Rear Screen, Inverted Mount (ceiling) Installation</b>	
<ul style="list-style-type: none"> <li>• Projector is completely hidden</li> <li>• Usually good ambient light rejection</li> </ul>	<ul style="list-style-type: none"> <li>• Requires separate room</li> <li>• Installation cost is usually higher</li> </ul>
<b>Rear Screen, Floor Mount with Mirror</b>	
<ul style="list-style-type: none"> <li>• Projector is completely hidden</li> <li>• Usually good ambient light rejection</li> <li>• Requires less space behind screen than other rear screen installations</li> </ul>	<ul style="list-style-type: none"> <li>• Requires separate room</li> <li>• Installation cost is usually higher</li> </ul>

**Ambient Light** ➤ In general, minimize or eliminate light sources directed at the screen. Contrast ratio in your images will be noticeably reduced if light directly strikes the screen, such as when a shaft of light from a window or floodlight falls on the image. Images may then appear washed out and less vibrant.

Throw distance is the distance measured from the front of the projector to the screen. This is an important calculation in any projector installation as it determines whether or not you have enough room to install your projector with a desired screen size and if your image will be the right size for your screen.

### ◀ **Throw Distance**

You can quickly estimate the throw distance by taking the width of the screen and multiplying it by the lens throw ratio; see Figure 3-2. The result of this calculation tells you roughly how far back the projector should be positioned from the screen in order to project a focused image large enough to fill the screen.

#### **Estimating Throw Distance**

Throw Distance (TD) = Screen Width (w) × Lens Throw Ratio

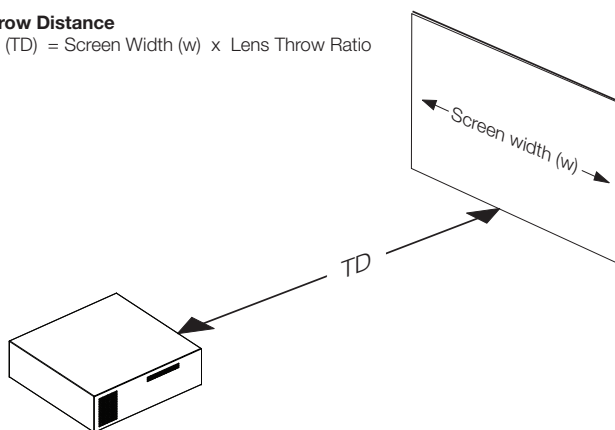

**Figure 3-2. Estimating Throw Distance**

Table 3-3 lists the available lens options for the VX-6000d and their associated throw ratios.

**Table 3-3. VX-6000d Lens Options and Throw Ratios**

Lens Option (Note 2)	Throw Ratio with Primary Lens Only	Throw Range in inches, with 96x54-inch (1.78:1) Screen		Throw Ratio with Primary Lens and Anamorphic Lens	Throw Range in inches, with 126.9x54-inch (2.35:1) Screen	
		Minimum	Maximum		Minimum	Maximum
Telesto B	1.39 - 1.66	133.44	159.36	Not Applicable (Note 2)		
Telesto C	1.70 - 2.27	163.20	217.92	1.60 - 1.74	203.04	220.81
Telesto D	2.40 - 4.10	230.40	393.60	1.81 - 3.18	229.69	403.54
Telesto E	4.20 - 6.65	403.20	638.40	3.16 - 5.00	401.00	634.50

**Notes:**

1. Throw distance does not affect image quality, provided these ranges are taken into account.
2. Only the Telesto C, D and E lenses can be used with the optional CineWide (secondary anamorphic) lens. Doing so affects the throw distances as shown here.

**Vertical and Horizontal Position**

Proper placement of the projector relative to the screen will yield a rectangular, perfectly-centered image that completely fills the screen.

Ideally, the projector should be positioned perpendicular to the screen and in such a way that the lens center is aligned with either the top or bottom edge of the screen area, and centered horizontally. See Figure 3-3.

**Ceiling Installation**

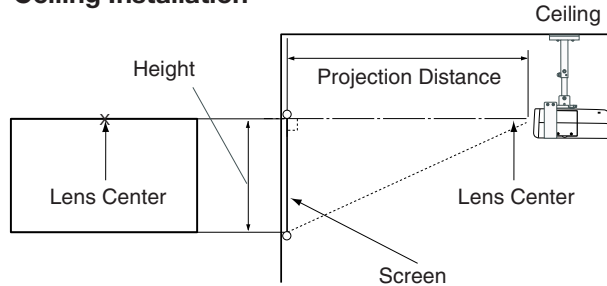

**Floor Installation**

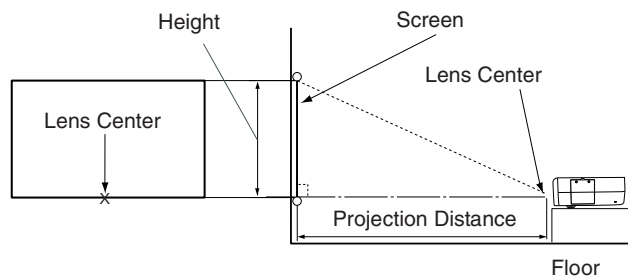

**Figure 3-3. Projector Placement**

**Vertical and Horizontal Lens Shift**

If it is not possible to align the projector and screen as shown in Figure 3-3, you can use the lens shift controls to center the image on the screen. Lens shift is generally expressed as a percentage of the screen height or width, as shown in Figure 3-4 and Figure 3-5.

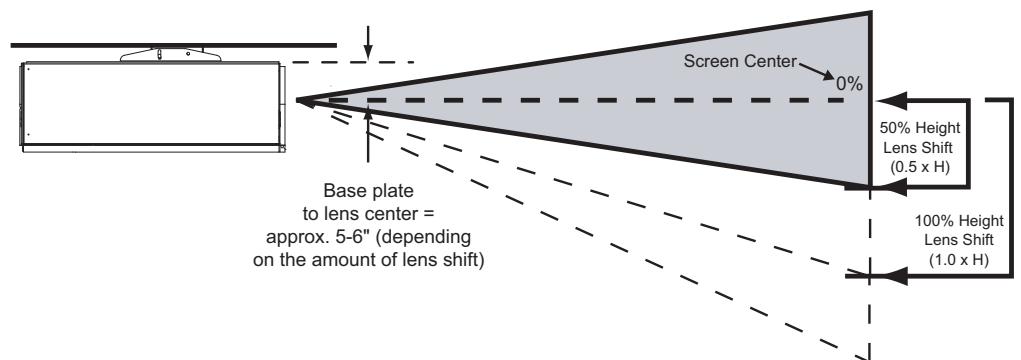

**Note:** This is a general example of lens shift. Lenses vary in their shift capabilities. **No particular lens or projector is used in this example.**

**Figure 3-4. Vertical Lens Shift (Example Only)**

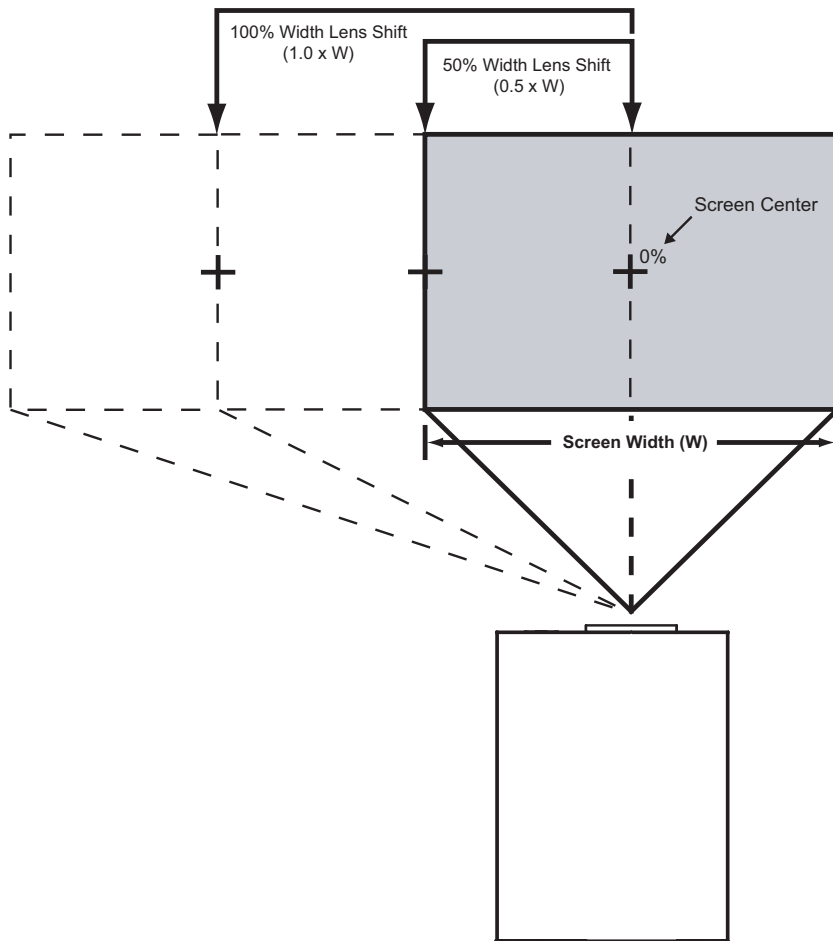

**Note:** This is a general example of lens shift. Lenses vary in their shift capabilities. **No particular lens or projector is used in this example.**

**Figure 3-5. Horizontal Lens Shift (Example Only)**

Table 3-4 lists the lens shift limits for each available VX-6000d lens, as percentages and absolute measurements with a 100 x 56 inch (1.78:1) screen.

**Table 3-4. Vertical and Horizontal Lens Shift Limits**

		Lens Option			
		Telesto B	Telesto C	Telesto D	Telesto E
<b>Lens Shift Limits, as Percentages of Screen Height or Width (Notes 1, 2 and 3)</b>					
Vertical (Notes 2 and 3)	Up	60%	61%	63%	38%
	Down	67%	75%	60%	67%
Horizontal (Note 2)	Left	20%	25%	22%	38%
	Right	20%	25%	22%	38%
<b>Lens Shift Limits in Inches, with a 100-by-56 inch (1.78:1) Screen</b>					
Vertical	Up	33.60	34.16	35.28	21.28
	Down	37.52	42.00	33.60	37.52
Horizontal	Left	20.00	25.00	22.00	38.00
	Right	20.00	25.00	22.00	38.00
<b>Notes:</b>					
1. With no vertical or horizontal lens shift, the lens center and screen center are aligned with each other.					
2. Vertical shift limits are percentages of the screen height. Horizontal shift limits are percentages of the screen width.					
3. <b>Vertical lens shift figures are for ceiling mount configurations.</b> For floor installations (where the projector is upright), reverse the up/down vertical lens shift percentages.					



In rear screen applications where space behind the projector is limited, a mirror may be used to fold the optical path, as shown in Figure 3-6. The position of the projector and mirror must be accurately set. If you are considering this type of installation, contact your dealer for assistance.

### ◀ **Folded Optics**

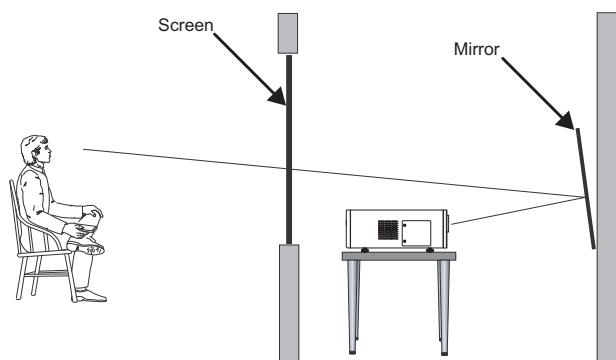

**Figure 3-6. Folded Optics**

Due to its extraordinarily high level of video processing performance, the DHD Controller may distribute video signals with a perceptible level of audio latency. In order to easily solve this issue, Runco recommends using the DHD Controller with a high-quality audio receiver that has the ability to effectively synchronize audio and video signals.

### ◀ **Audio/Video Synchronization Issues**

Most mainstream audio receiver/switchers have the ability to synchronize the audio and video to the Advanced Television Systems Committee (ATSC) prescribed tolerances. According to the ATSC, the sound program should never lead the video program by more than 15 milliseconds, and should never lag behind the video program by more than 45 milliseconds.

In addition, many A/V receivers introduce additional latency that needs to be compensated for during the installation. Table 3-5 shows the amount of possible audio latency given different signal input timings.

**Table 3-5. Possible Audio Latency for Various Input/Output Timings**

Input Timing	Possible Audio Latency (milliseconds)
480i	133
480p	83
576i	160
576p	100
720p/50	100
720p/60	83
1080i/25	160
1080i/30	133
1080p/24	125
1080p/50	80
1080p/60	67

**Other Considerations** ➤

Other considerations and tips that can help improve your installation:

- Keep the ambient temperature constant and below 35°C (95°F). Keep the projector away from heating or air conditioning vents. Changes in temperature may cause drifts in the projector circuitry, which may affect performance.
- Keep the projector away from devices that radiate electromagnetic energy such as motors and transformers. Common sources of these include slide projectors, speakers, power amplifiers and elevators.

---

### **3.4 Installing the Optional CineWide Lens Mount**

If you are installing a standard (non-CineWide) VX-6000d, skip this step and proceed with **Mounting the VX-6000d** (page 31).

If you are installing a VX-6000d/CineWide, proceed with **Installing the Fixed CineWide Base Plate (VX-6000d/CineWide)** (page 30).

If you are installing a VX-6000d/CineWide with AutoScope, proceed as follows to install the AutoScope lens motor.



**Note**

1. Do not install the CineWide lens yet, only the fixed CineWide base plate or AutoScope lens motor. You will install the CineWide lens after you install the projector and adjust the primary lens.
2. Some components shipped with your projector may differ slightly from what is shown in these instructions.

Figure 3-7 shows the VX-6000d/CineWide with AutoScope motor assembly.

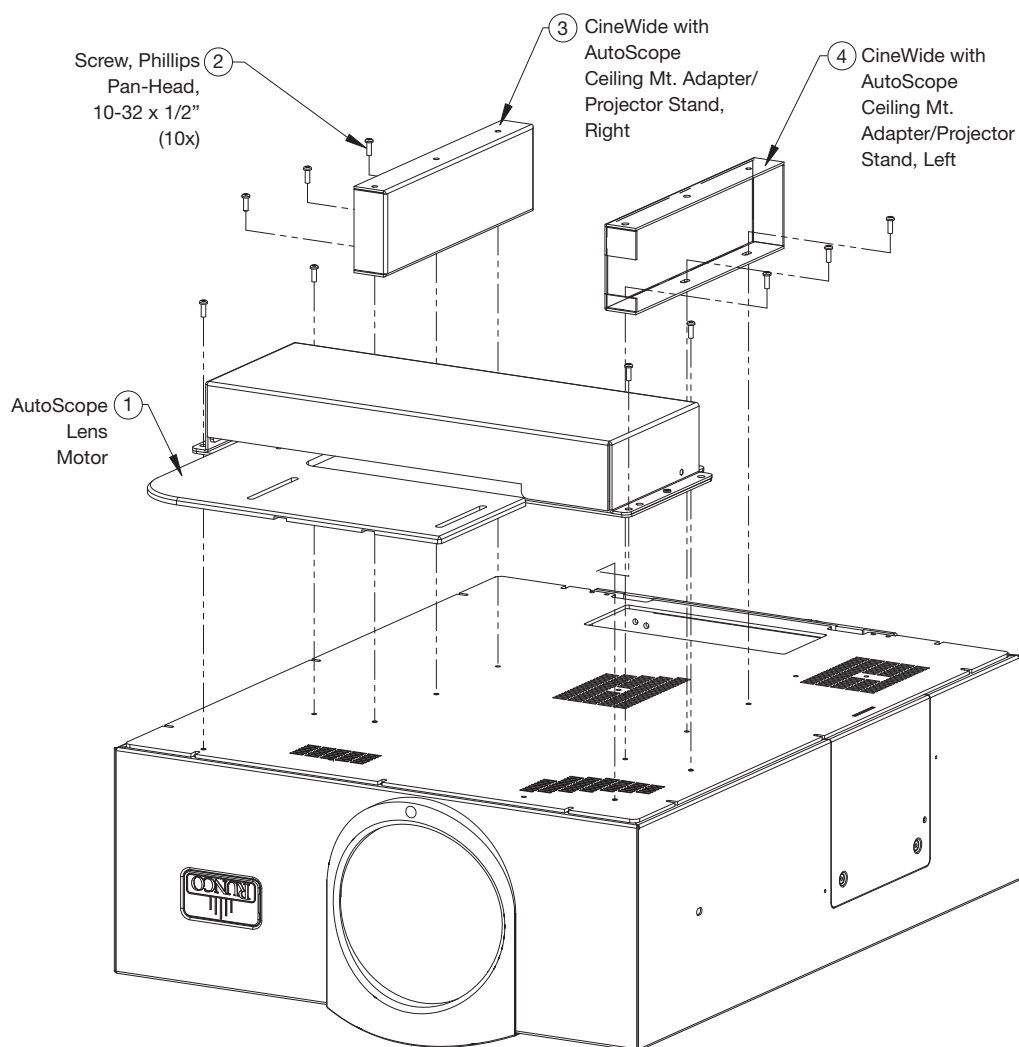

◀ **Installing the AutoScope Lens Motor (VX-6000d/CineWide with AutoScope)**

**Figure 3-7. VX-6000d/CineWide with AutoScope Motor Assembly – Exploded View**

**Remove Projector Front Feet:** Place the projector upside down on a blanket or other soft surface. Loosen and remove the two front feet on the projector using a Phillips screwdriver.

**Install Ceiling Mount Adapters/Projector Stands:** For ceiling installations, the adapters bring the attachment points for the projector mounting rails (included with the projector ceiling mount kit) from the bottom of the projector up and around the AutoScope lens motor housing. For floor installations (where the projector is upright), the adapters allow the projector to lie flat on the mounting surface.

Using six (6) each of the supplied, 10-32 x 1/2" Pan-Head Phillips screws (item #2), attach the AutoScope Ceiling Mount Adapters/Projector Stands (items #3 and #4) to the projector as shown in Figure 3-8.

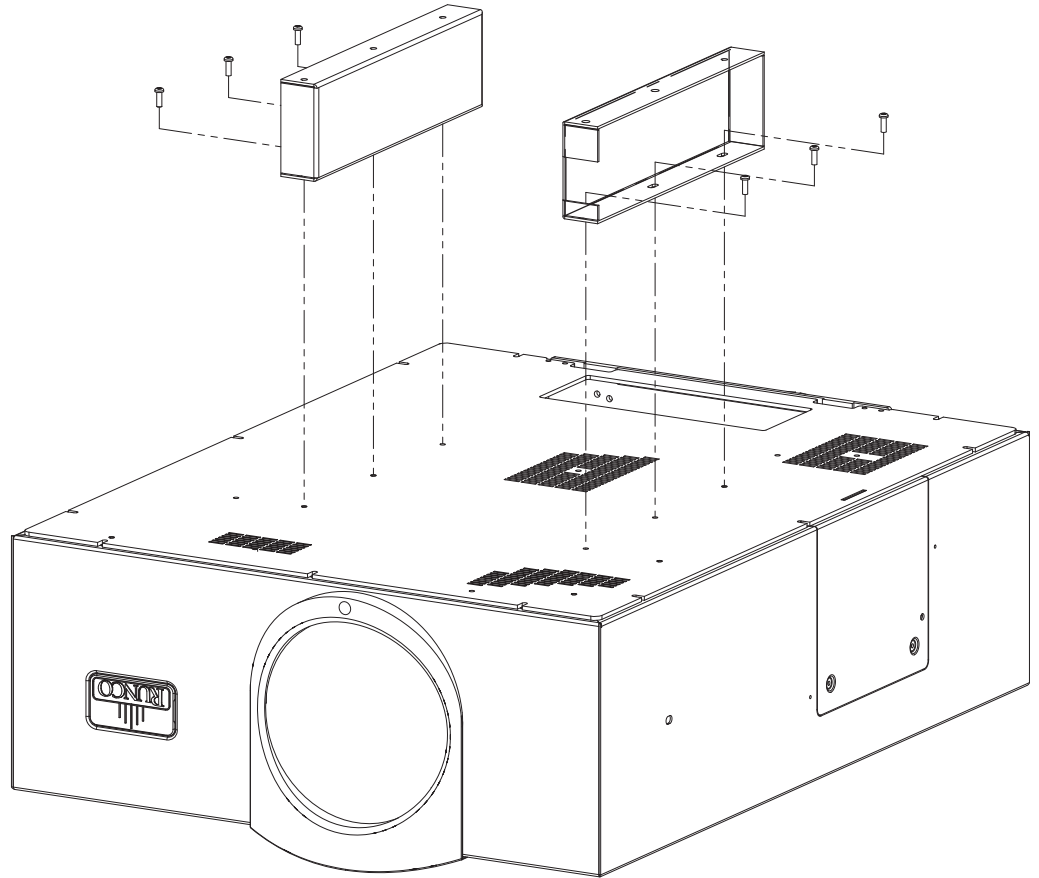

**Figure 3-8. VX-6000d with Ceiling Mount Adapters/Projector Stands**



**Caution**

*DO NOT OVER-TIGHTEN THE SCREWS.*

**Install Lens Motor:** Position the AutoScope Lens Motor (item #1) as shown in Figure 3-9. Line up the mounting holes on the lens motor housing with those on the underside of the projector. Secure the motor to the projector with the four remaining 10-32 x 1/2" Pan-Head Phillips screws (item #2).

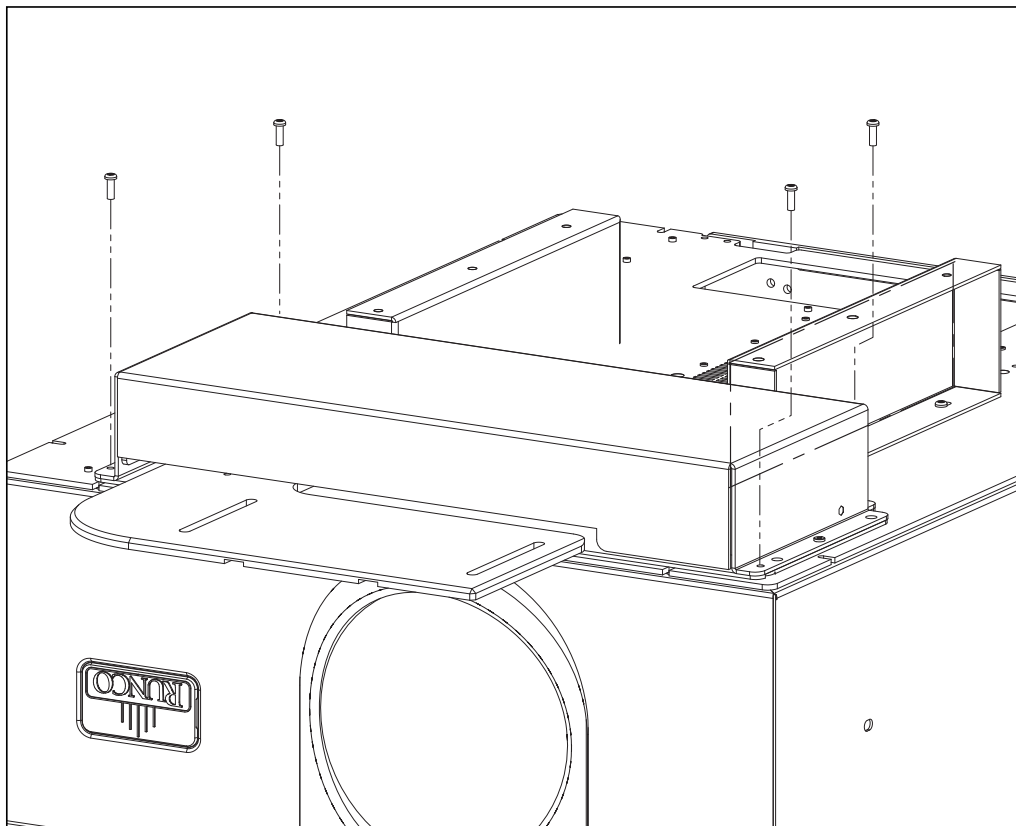

**Figure 3-9. AutoScope Lens Motor Installation**

After you have installed the AutoScope lens motor, proceed with **Mounting the VX-6000d** (page 31).

**Installing the Fixed  
CineWide Base Plate  
(VX-6000d/CineWide)** ➤

To install the fixed CineWide base plate on a VX-6000d/CineWide:

1. Place the projector upside down on a blanket or other soft surface.
2. Line up the mounting holes on the lens mount base plate with those on the bottom of the projector, directly below the primary lens.
3. Secure the base plate to the projector with the screws provided for this purpose.

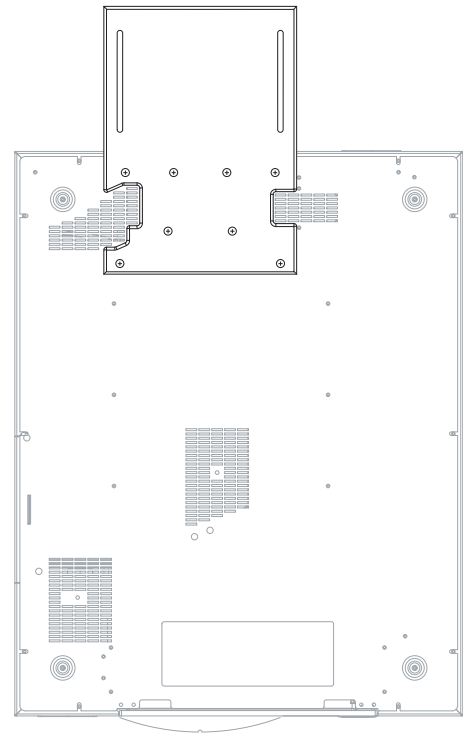

There are several methods for mounting the projector. Depending on your chosen installation, one method may be more suitable than another.

In typical front and rear screen installations, the projector can be mounted to a secure and level surface such as a table or cart. Carts are useful when moving a projector during a presentation or from site to site. If possible, lock the wheels when it's in position to prevent it from being moved during a presentation.

For fixed installations, and for those that want the projector out of sight or have a limited space for projector and audience, you can invert the VX-6000d and suspend it from the ceiling using a specially-designed ceiling mount fixture.

**Note**

*Use only the Runco-approved ceiling mount kit (part number 956-0074-00) designed for your projector. Install the mount kit according to the instructions provided with it.*

The projector can also be inverted and placed in an enclosure above and behind the viewing area. Install four feet on the inside bottom surface of the enclosure on which the projector can rest. A variety of materials can be used for this purpose (for example, rubber crutch tips or turntable feet).

If the VX-6000d is ceiling-mounted and the screen is significantly lower than the projector, you can tilt the projector at a slight angle by adjusting the ceiling mount.

If you do this, you may need to shift the image using the OSD controls, to compensate. For detailed instructions, refer to **Using the On-Screen Menus** on page 51.

Proceed as follows to connect the DHD Controller to the VX-6000d, your video sources, external controller(s) – if present – and AC power.

When connecting your equipment:

- Turn off all equipment before making any connections.
- Use the correct signal cables for each source.
- Route all cables through the cable opening at the bottom rear of the projector (see Figure 2-1).
- Ensure that the cables are securely connected. Tighten the thumbscrews on connectors that have them.

The VX-6000d is designed to receive only video input signals directly from the companion DHD Controller/Scaler/Processor. Connect all signal sources to the appropriate inputs on the rear panel of the DHD Controller. The signal from the DHD Controller is then output to the VX-6000d projector through an HDMI cable.

**Note**

*You CANNOT connect signal sources directly to the VX-6000d. They MUST be routed through the DHD Controller for proper operation.*

### 3.5 Mounting the VX-6000d

#### ◀ Floor Mounting (Upright)

#### ◀ Ceiling Mounting (Inverted)

#### ◀ Adjusting the Projection Angle

### 3.6 Connections to the VX-6000d and DHD Controller

#### ◀ Connecting the DHD Controller to the VX-6000d

Connect the **HDMI** and **Display Control (RS-232)** outputs of the DHD Controller to the corresponding inputs of the VX-6000d; see Figure 3-10.

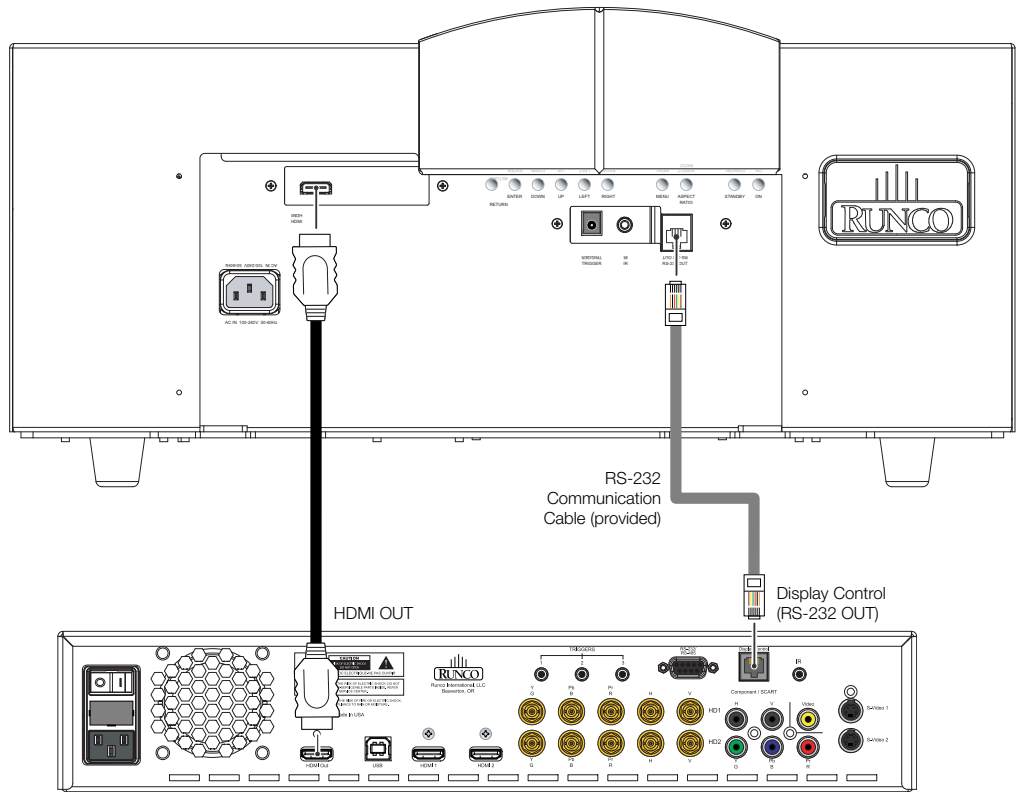

**Figure 3-10. Connecting the VX-6000d to the DHD Controller**



Connect your video sources to the DHD Controller as shown and described in the sections that follow.

◀ **Connecting Source Components to the DHD Controller**

**HDMI Source Connections:** See Figure 3-11.

*Use the HDMI inputs whenever possible. This ensures the highest video quality because the signal is carried in the digital domain throughout the entire signal path, from source component output into the projector.*



**Note**

*You can also connect computers with DVI output to these inputs. Refer to **Supported Timings** on page 91 for a list of compatible input signals.*

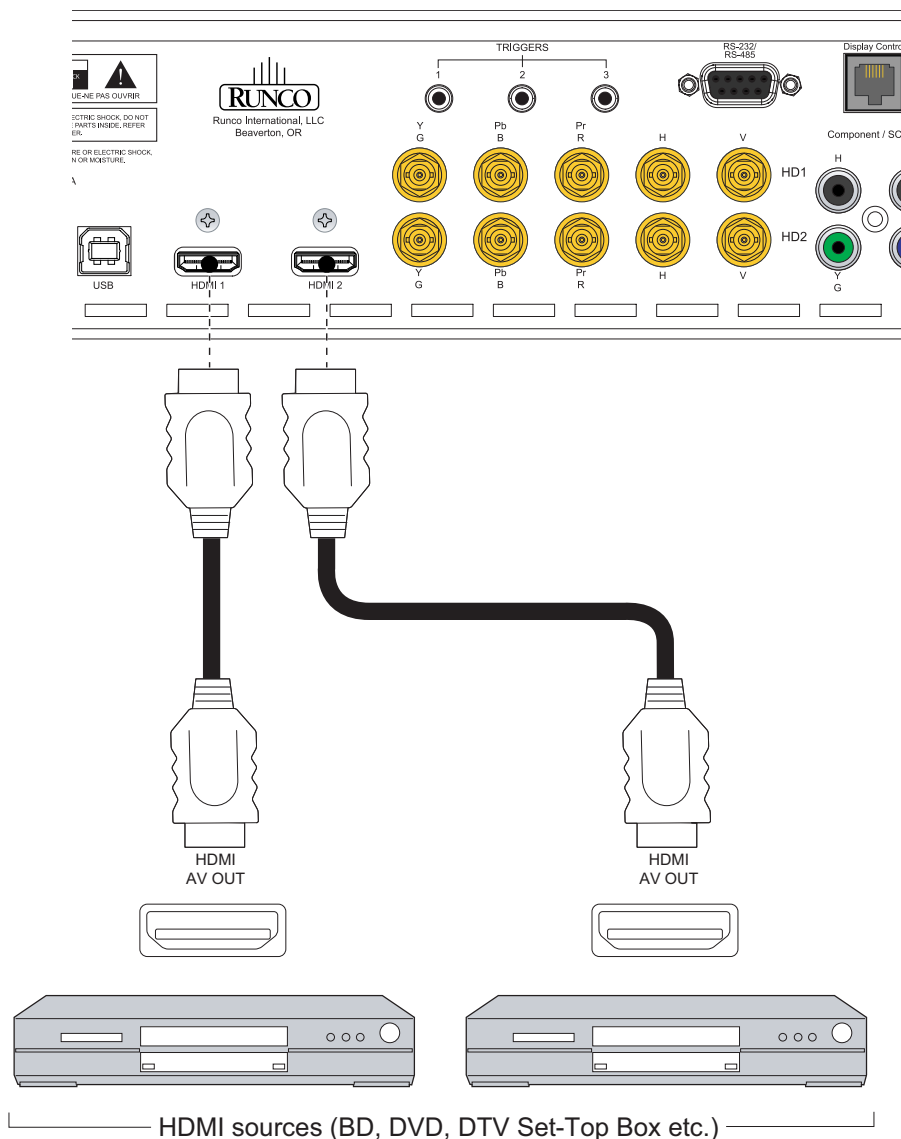

**Figure 3-11. HDMI Source Connections**

**Component Video Source Connections:** Connect your component video sources to the HD1, HD2 and/or Component/SCART inputs as shown in Figure 3-12.

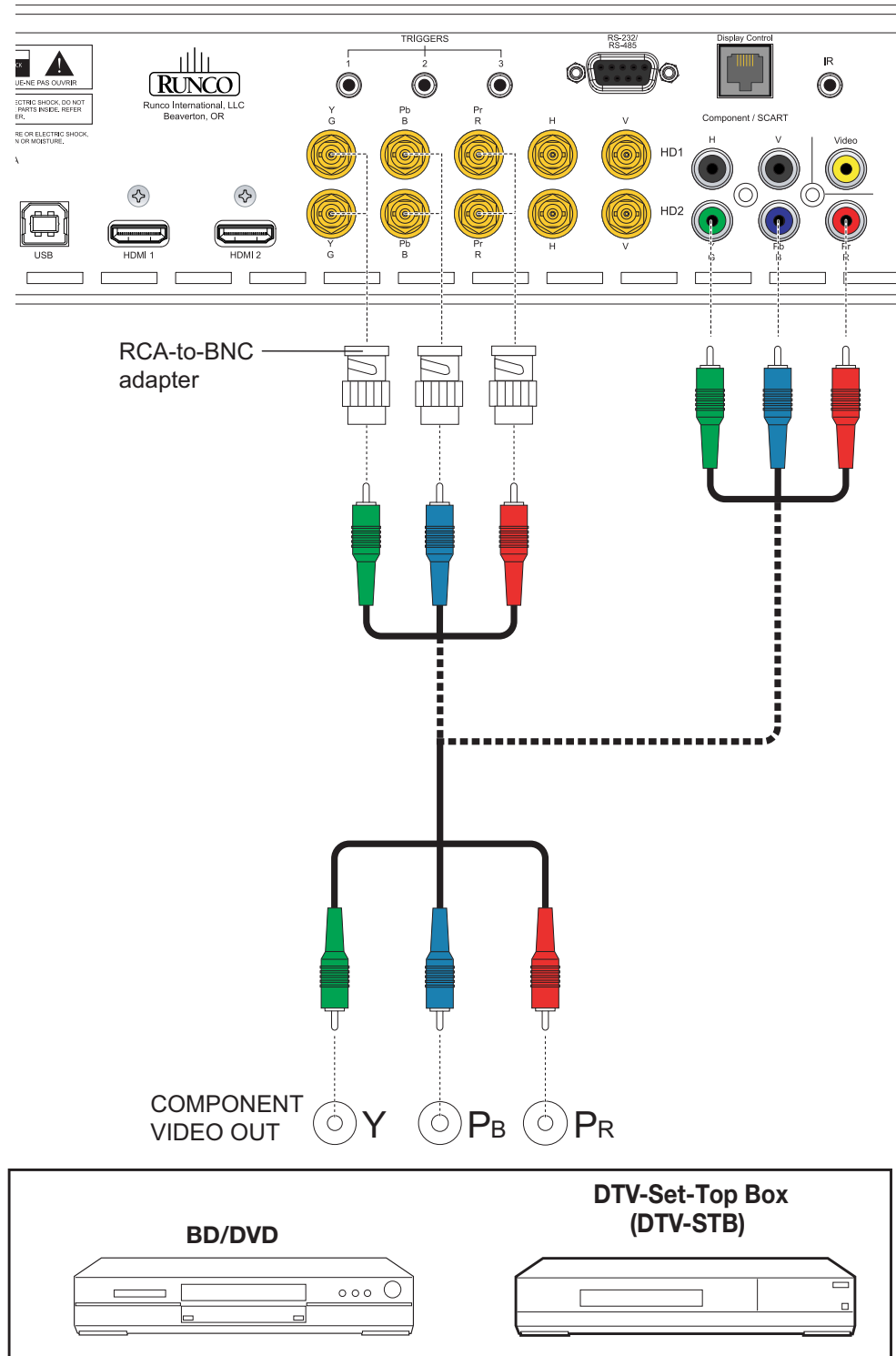

**Figure 3-12. Component Video Source Connections**

**RGBHV Source Connections:** Connect personal computers and/or other RGB sources to the HD1, HD2 and/or Component/SCART inputs as shown in Figure 3-13.

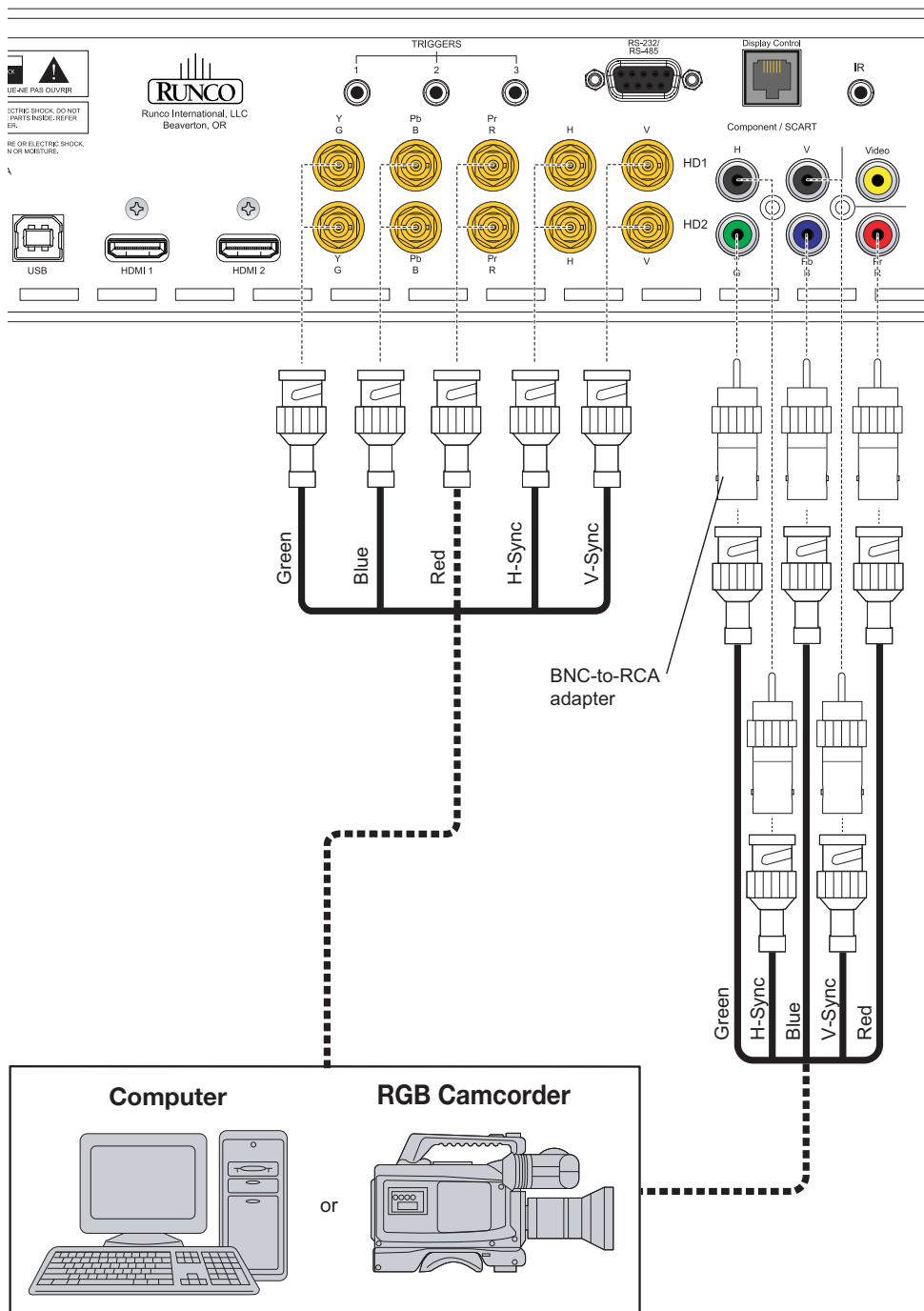

**Figure 3-13. RGBHV Source Connections**

**SCART RGBS Source Connections:** Connect the green, blue and red outputs from your SCART source to the Component/SCART input on the DHD Controller. Connect the sync output from your SCART source to the Video input on the DHD Controller. See Figure 3-14.

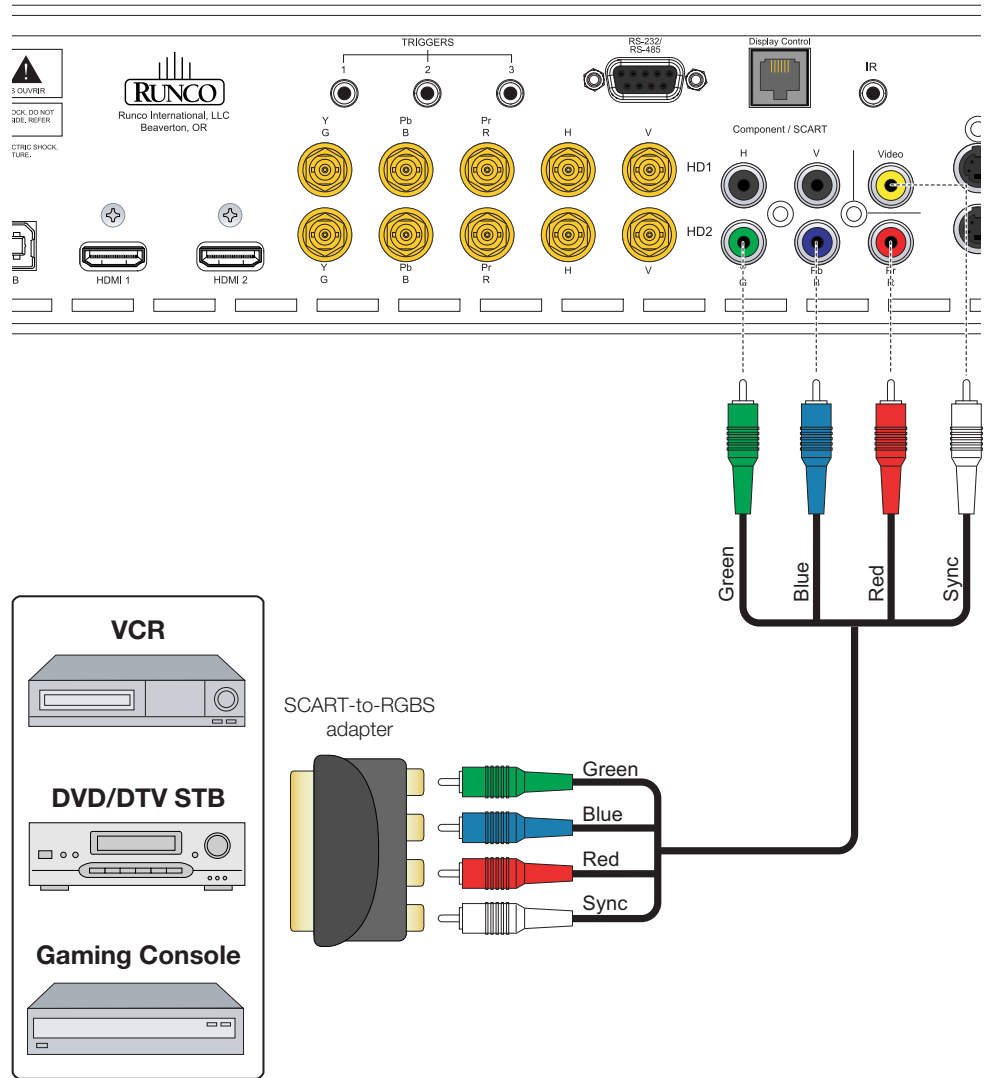

**Figure 3-14. SCART RGBS Source Connections**

**Composite and S-Video Source Connections:** See Figure 3-15.

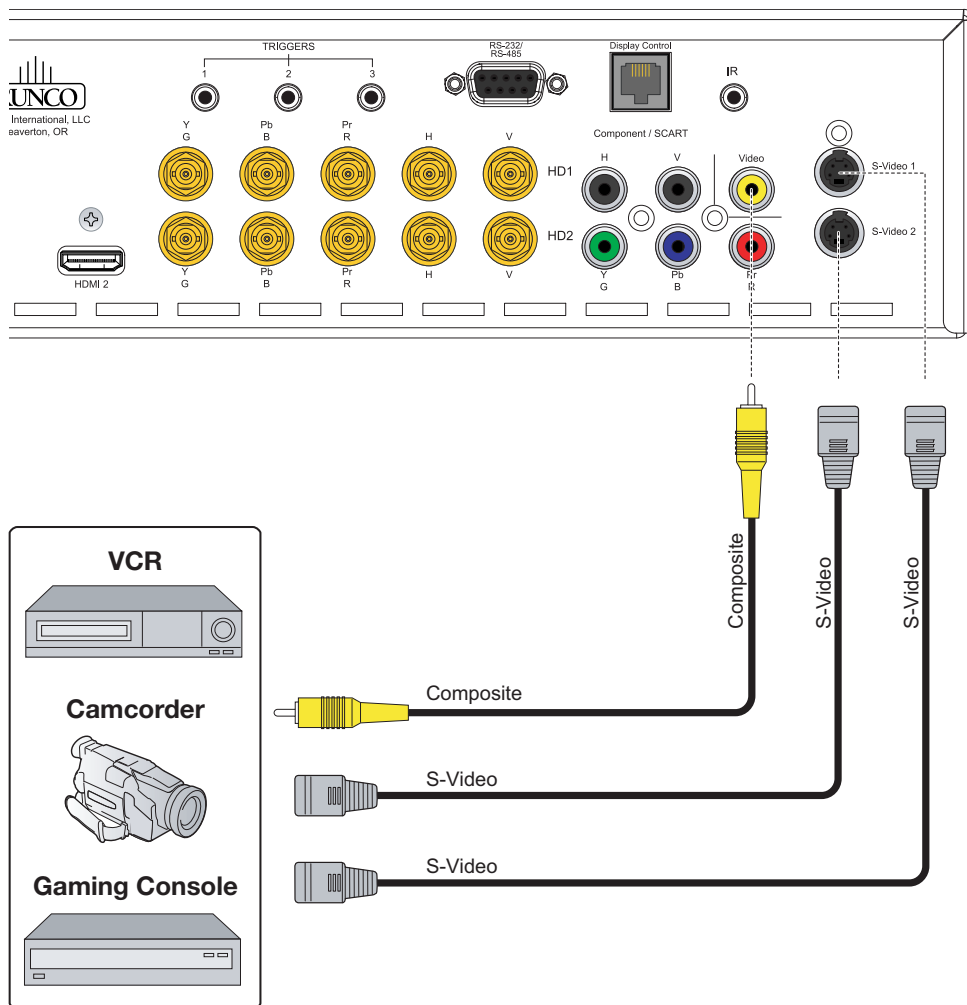
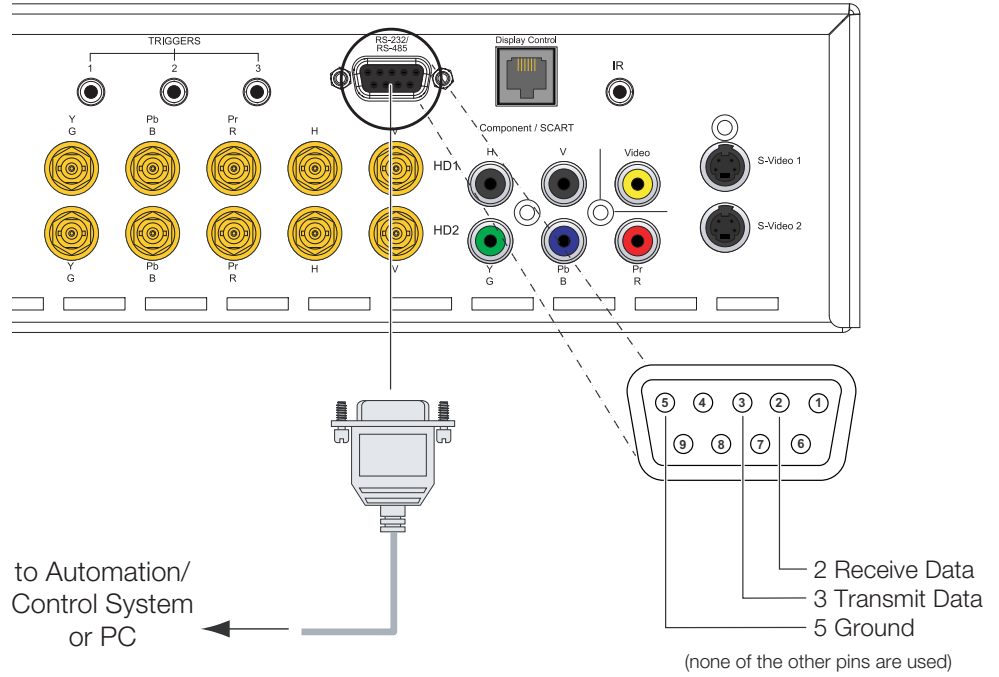

**Figure 3-15. S-Video and Composite Video Source Connections**

**RS-232 Controller Connection**

Use a straight-through, 9-pin RS-232 cable to connect a PC or control/automation system (if present) to the RS-232 port on the DHD Controller; see Figure 3-16.

For more information about using this connection, refer to **External Control** on page 79.



**Figure 3-16. RS-232 Control System Connection**

**DHD Controller:** If your VX-6000d is equipped with a CineWide with AutoScope system, connect the AutoScope lens motor to a 12-volt trigger output on the DHD Controller; see Figure 3-17.

◀ **Connecting 12-volt Trigger Outputs to External Equipment**

Similarly connect other 12-volt trigger-activated equipment (such as retractable screens or screen masks) to the other trigger outputs.

For more information on using the DHD Controller triggers, refer to **Triggers** on page 70.

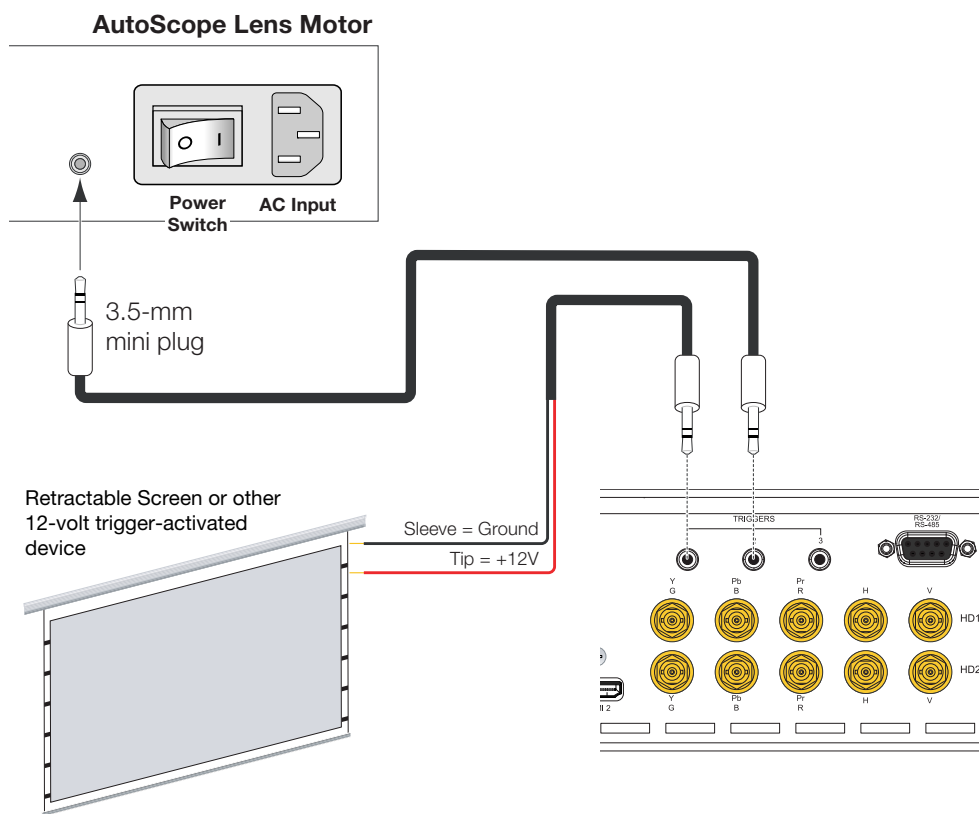

**Figure 3-17. 12-volt Trigger Output Connections (from DHD Controller)**

**Projector:** The projector is equipped with an additional 12-volt trigger output. This trigger activates when the projector is turned on. Connect it to your retractable screen or other, 12-volt trigger-activated equipment as shown in Figure 3-18.

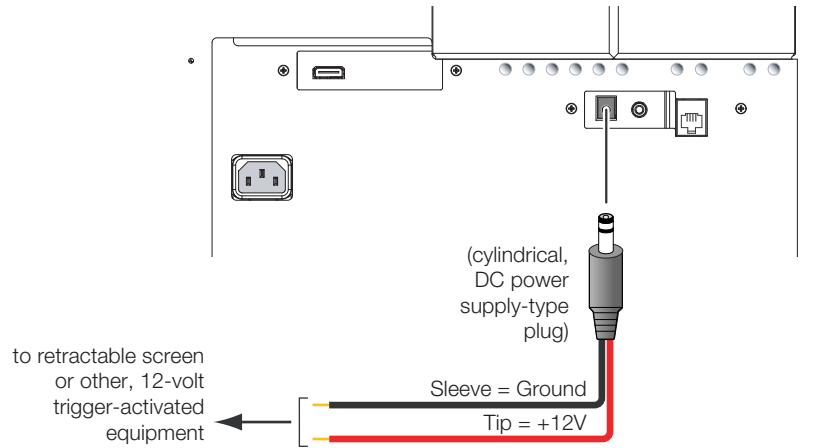
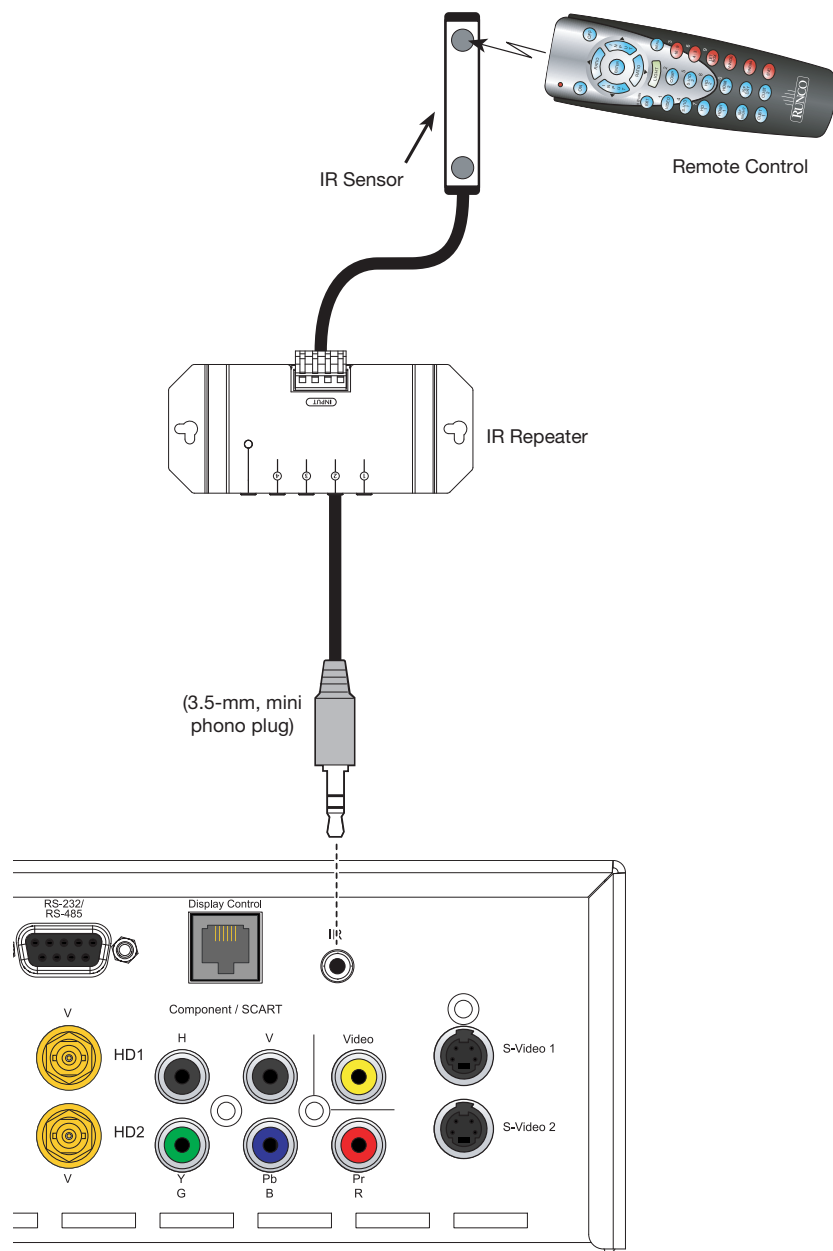

**Figure 3-18. 12-volt Trigger Output Connection (from Projector)**



If infrared signals from the remote control cannot reach the DHD Controller due to excessive distance or obstructions such as walls or cabinet doors, you can connect an external IR receiver to the DHD Controller to extend the range of the remote control. See Figure 3-19.

◀ **Connecting an External IR Receiver to the DHD Controller**



**Figure 3-19. External IR Receiver Connection**

**Connecting to AC Power** ➤

**Projector/DHD Controller:** The VX-6000d system includes two (2) AC power cords (one each for the projector and DHD Controller).

Plug the female end of one power cord into the AC receptacle on the rear of the VX-6000d (AC 100V ~ 240V). Then, connect the other end to your AC power source. Similarly connect the DHD Controller to a nearby AC outlet.

**AutoScope Lens Motor:** With AutoScope-equipped projectors, a third power cord is provided for the lens motor. Plug the female end of the AC power cord into the AC input on the rear of the lens motor assembly. Connect the other end to a 110 VAC power source.



**Caution**

*The input voltage to the AutoScope lens motor must be between 100 and 120 VAC. **Do not connect the AutoScope lens motor to a 200-240 VAC power source!***

**3.7  
Turning on the Power**

1. Turn on your source components.
2. Turn on the main power switch at the rear of the DHD Controller.
3. If this is an AutoScope-equipped projector, turn on the main power switch at the rear of the AutoScope lens motor. The lens motor power switch is located next to the AC input (see Figure 3-17).
4. Press the **ON** button on the remote control – or the **ON/STANDBY** (⏻) button on the DHD Controller front panel – to turn on the system. The vacuum fluorescent display on the DHD Controller front panel briefly displays “Initializing System,” followed by “Starting VX-2000/6000.”
5. When the projector has completed its initialization and is ready for use, the fluorescent display on the DHD Controller indicates the active source, input resolution/frame rate and aspect ratio; for example:

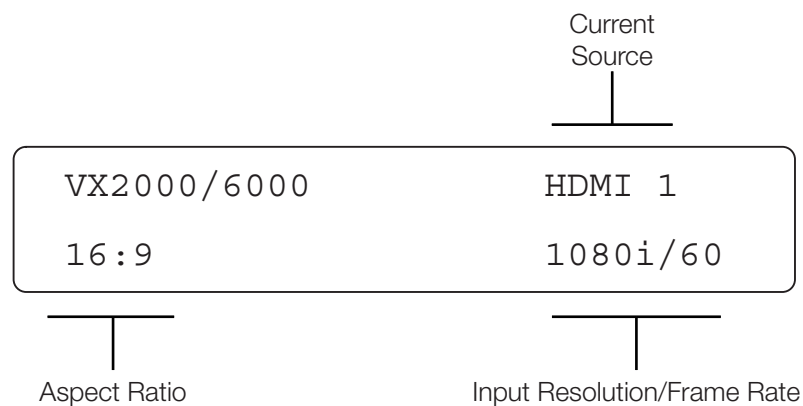

Lens zoom and focus are motorized adjustments that are adjustable using the Setup remote control (Figure 2-6). This allows you to adjust the focus and image size while at the screen for more accurate results. The remote control has a range of approximately 100 feet (30.5 meters) for long throw distances.

The IR receiver for the lens motor assembly is located on the projector behind the front Runco logo cover. Rotate the logo cover 90 degrees as shown to reveal the IR receiver opening.



### 3.8 Primary Lens Adjustments

1. With the IR receiver revealed on the front of the projector, press the **VX6K** button on the Setup remote control to display the Lens Control menu page.
2. Point the remote directly at the projector for maximum range.
3. To focus the projected image, press and hold the **FCUS+** or **FCUS-** button.

◀ **Focus**

To make the picture smaller (zoom out), press and hold the **ZOOM-** button. To enlarge the picture (zoom in), press and hold the **ZOOM+** button.

◀ **Zoom**

Press the **IRIS** button repeatedly to select an optical aperture or *iris* size (large or small).

◀ **Iris**

To change the projected image position, use a 3/16" hex driver to shift the lens in the desired direction; see Figure 3-20. The vertical lens shift control is at the top of the projector; the horizontal lens shift control is on the same side of the projector as the lamp compartment cover. (The tool will automatically center on top of the adjustment nut when inserted into the access hole.)

◀ **Vertical and Horizontal  
Lens Shift**

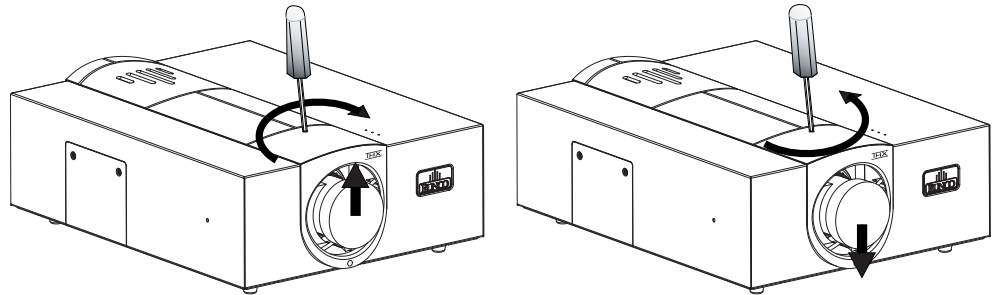
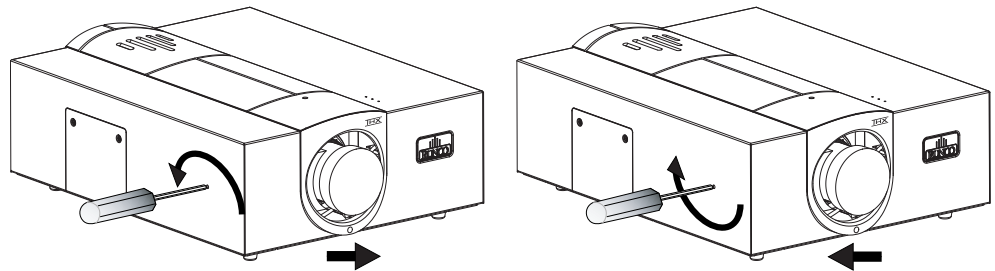
**Vertical****Horizontal****Figure 3-20. Vertical and Horizontal Lens Shift Adjustments**

### 3.9 Adjusting the Picture Orientation

By default, the VX-6000d is configured for a “floor/front” installation, in which the projector is installed upright and in front of the screen. If it is installed behind the screen and/or mounted on a ceiling, you must change the picture orientation. To do this:

1. On the DHD Controller remote control or front panel, press **MENU**.
2. Select **Service** from the Main Menu and enter the Service Menu passcode.

**Note**

*You must enter a passcode to access the Service menu for the first time after turning on the system.*

3. Select **Display Device** from the Service Menu.
4. Select **Configure** from the Display Device menu, then select **Installation**.
5. Select **Orientation**, then choose Floor/Rear, Ceiling/Front or Ceiling/Rear, to match the installation method.

If you are installing a CineWide-equipped projector, proceed as follows to install and adjust the anamorphic lens.



**Note**

***It is extremely important that the primary lens is properly adjusted before you install the anamorphic lens. Ensure that the image from the primary lens is perfectly centered on the screen.***

The VX-6000d Anamorphic lens mount kit consists of everything shown in Figure 3-21. Some components shipped with your projector may differ slightly from what is shown in these instructions. If any items are missing or damaged, please contact your Runco dealer or Runco Customer Service at (800) 23-RUNCO.

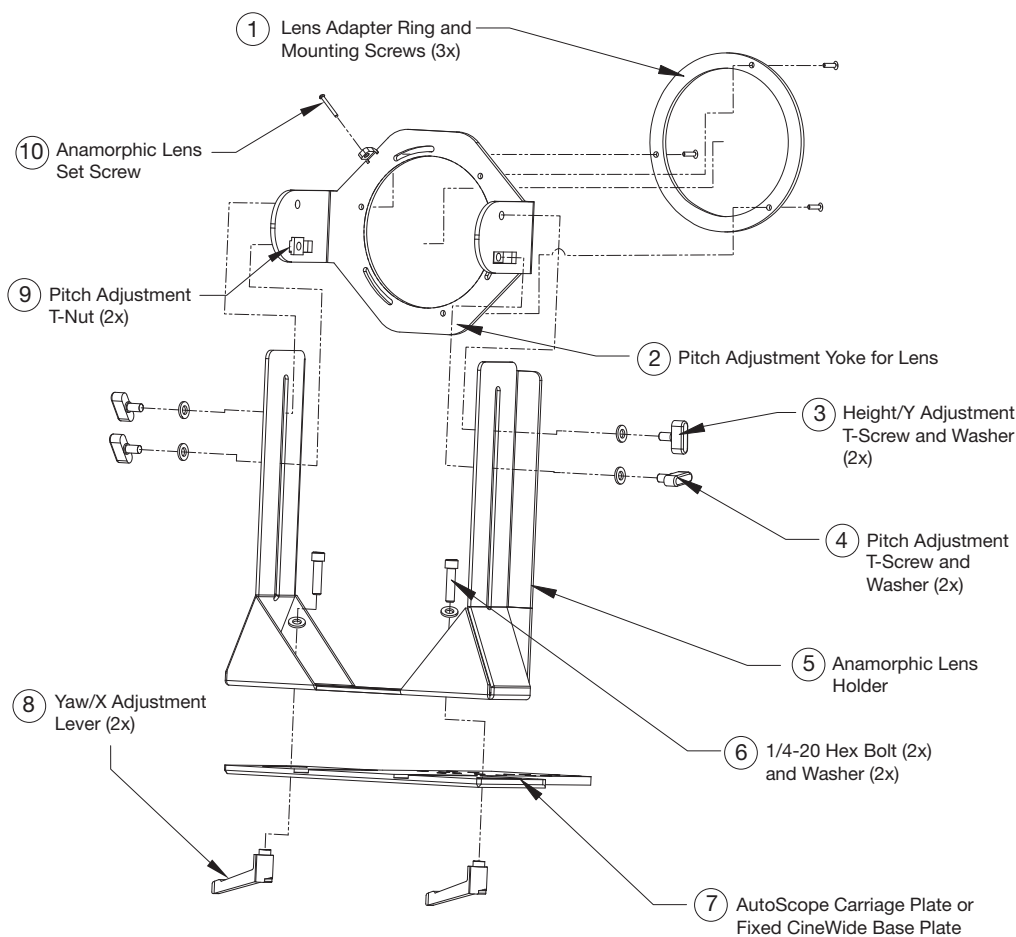
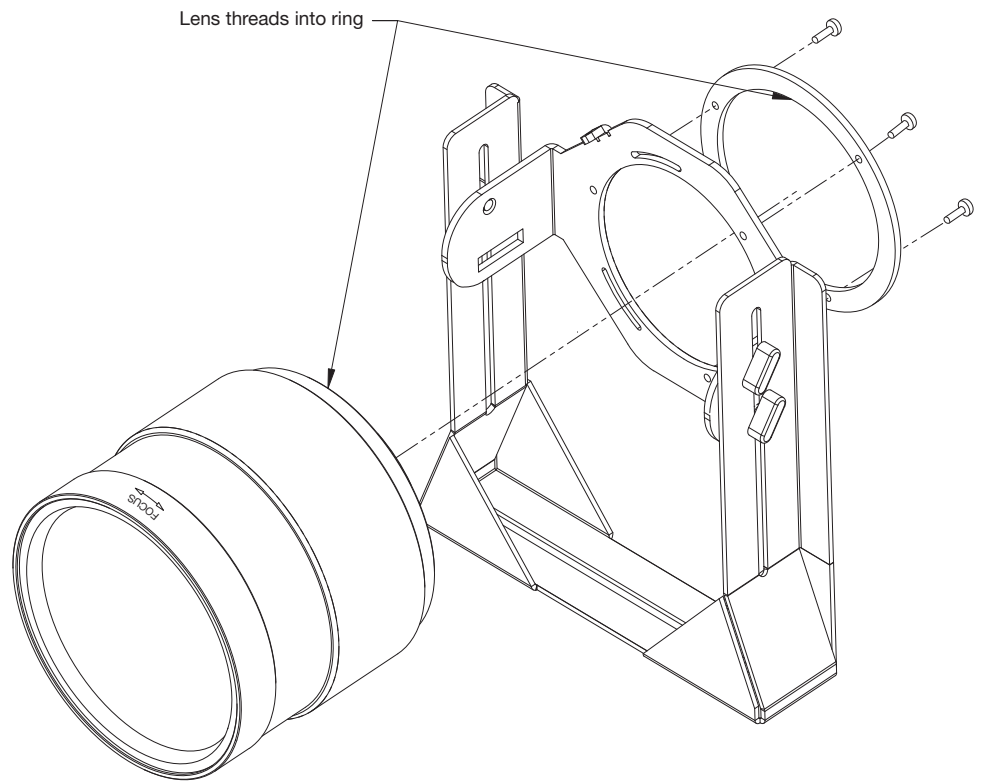

**Figure 3-21. VX-6000d Anamorphic Lens Mounting Assembly - Exploded View**

### **3.10 Installing and Adjusting the CineWide Anamorphic Lens**

◀ **Attach Lens Mounting Assembly to Lens Motor Carriage Plate (CineWide with AutoScope) or Base Plate (fixed CineWide)**

1. Remove the two Yaw/X Adjustment Levers (item #8) from the bottom of the Anamorphic Lens Holder (item #5).
2. Place the Anamorphic Lens Holder on top of the AutoScope Carriage Plate or fixed CineWide base plate (item #7). Position the bracket so that the long slot at the bottom of the lens holder is perpendicular to the corresponding slots on the carriage plate or base plate.
3. Secure the Anamorphic Lens Holder to the plate using the Hex Bolts/Washers (item #6) and Yaw/X Adjustment Levers that you removed in Step 1.
4. Use the Lens Mounting Screws to attach the Lens Adapter Ring (item #1) to the Pitch Adjustment Yoke (item #2); see Figure 3-22. (Use the round, threaded holes on the yoke.)
5. Use the Height/Y Adjustment T-Screws (item #3), Pitch Adjustment T-Screws (item #4) and T-Nuts (item #9) to attach the Pitch Adjustment Yoke and Lens Adapter Ring to the Anamorphic Lens Holder. **The Yoke should be as close to the primary lens as possible.**
6. Attach the lens to the Lens Adapter Ring by threading it clockwise.



**Figure 3-22. Attaching the Anamorphic Lens to the Lens Adapter Ring**

**(Skip this step if you are installing a fixed CineWide anamorphic lens.)**

CineWide with AutoScope maintains constant image height independent of the aspect ratio, while using the full display resolution of the projector. It accomplishes this by moving the anamorphic lens in front of the primary lens when widescreen material is being viewed. When the viewer transitions back to 16:9 or 4:3 source material, the anamorphic lens moves out of the light path.

To configure the lens motor trigger on the DHD Controller for proper AutoScope operation:

1. Project a 2.35:1 aspect ratio test pattern or other image on the screen.
2. On the DHD Controller remote control or front panel, press **MENU**.
3. Select **Service** from the Main Menu and enter the Service Menu passcode.

**Note**

*You must enter a passcode to access the Service menu for the first time after turning on the system.*

4. Select **Triggers** from the Service menu.
5. Assign the trigger output to which the lens motor is connected to the Cinema and Virtual Cinema aspect ratios. This enables the lens motor to move the anamorphic lens into position (in front of the primary lens) when either aspect ratio is selected.
6. Select the Cinema aspect ratio to move the anamorphic lens into position, if it isn't already. To do this, press **CINEMA** on the DHD Controller remote control (Figure 2-5), or press ▲ or ▼ repeatedly with no menus visible on-screen.

**Adjusting the Horizontal (X) Lens Position:**

1. Project a white field on the screen.
2. Loosen the Yaw/X-Adjustment Levers underneath the lens.
3. Slowly move the anamorphic lens into place so that there are no shadows on either side of the screen:

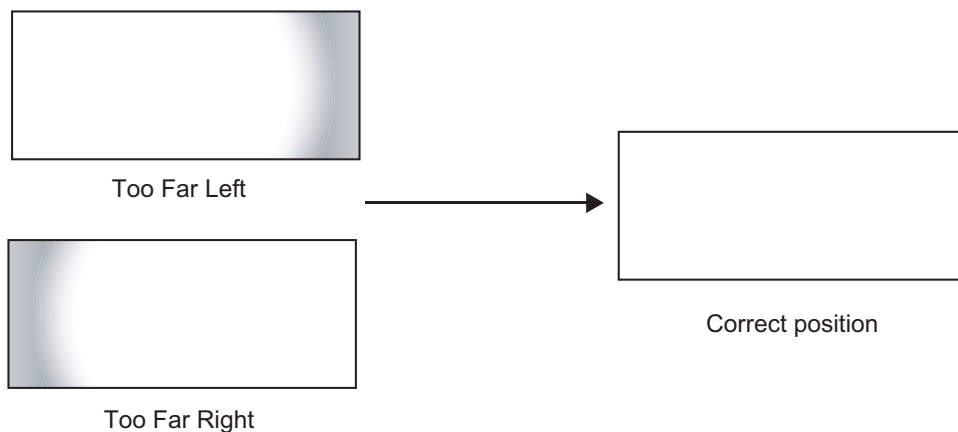

4. When the horizontal position is properly set, tighten the Yaw/X-Adjustment Levers to secure the lens in place.

### ◀ Configure Lens Motor Trigger (CineWide with AutoScope)

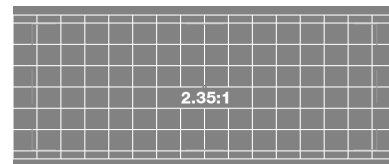

### ◀ Adjust the Anamorphic Lens

**Adjusting the Height (Y):** With the white field still on-screen, loosen the Height/Y Adjustment T-Screws on either side of the lens. Then, slowly move the anamorphic lens into place so that there are no shadows on the top or bottom of the screen:

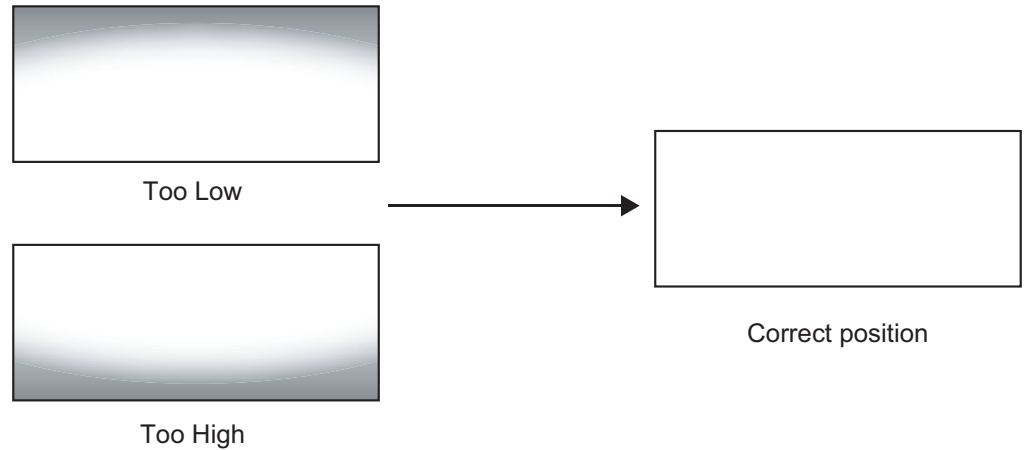

When the height is properly set, tighten the Height Adjustment T-Screws to secure the lens in place.

**Pitch (Angle):** Next, angle the lens to even out any top-to-bottom pincushion distortion. To do this, loosen the Pitch Adjustment T-Screws (directly below the Height/Y Adjustment T-Screws) on either side of the lens to allow it to pivot freely. Then, adjust the anamorphic lens angle so that the projected image is rectangular:

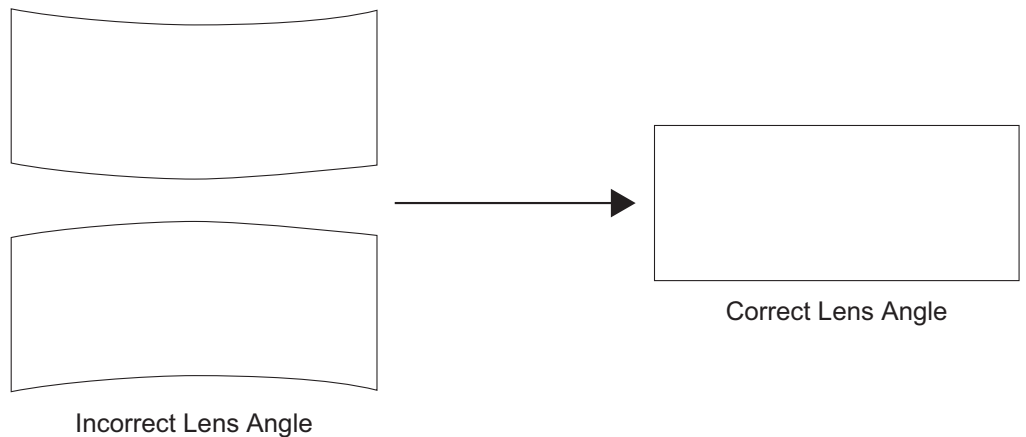

The anamorphic lens will almost always be angled with respect to the projector; this is normal.

Once the proper lens angle has been set, firmly tighten the Pitch Adjustment T-Screws to secure the lens in place.



**Note**

*There may be some pincushion distortion even after the lens is properly adjusted, especially at shorter throw distances. If this is the case, Runco recommends that you slightly over-scan the image into the screen frame area to mask the distortion.*



**Adjusting the Yaw:** Loosen the Yaw/X-Adjustment Levers to allow the lens to pivot freely from side to side. Then, angle the lens to even out any left-right pincushion distortion:

### Anamorphic Lens (Top View)

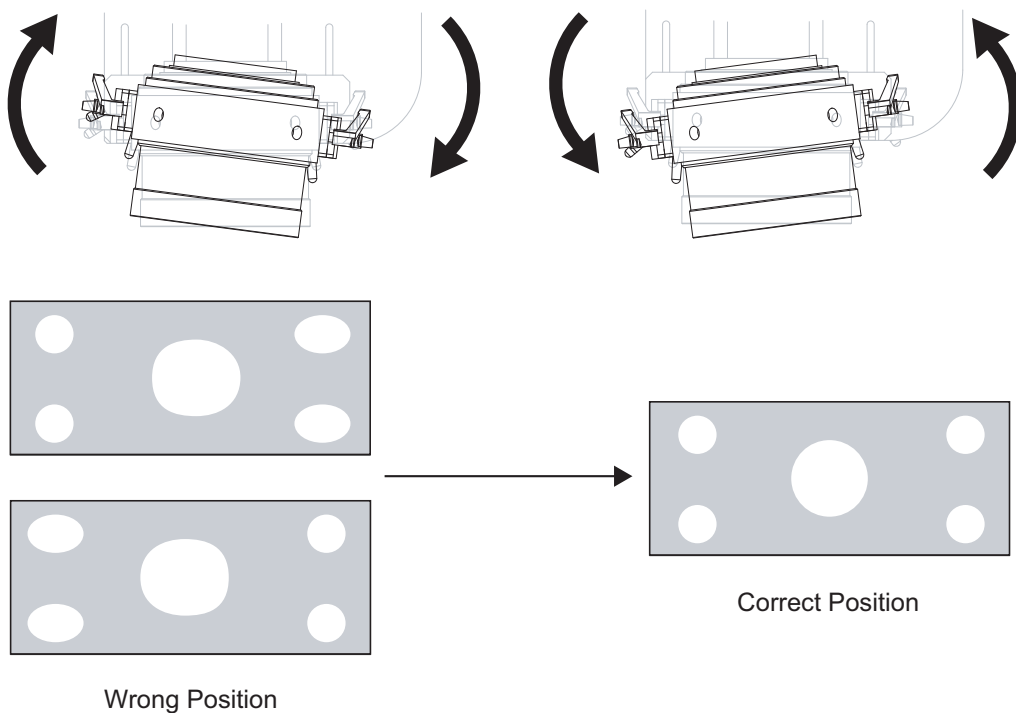

Once the proper lens angle has been set, firmly tighten the Yaw/X-Adjustment Levers to secure the lens in place.

### Adjusting the Geometry:

1. Input an anamorphic cross-hatch test pattern to the projector.
2. Unscrew the Anamorphic Lens just enough to allow it to rotate freely.
3. Grasp the lens by the center ring and rotate the lens until the image is properly anamorphic:

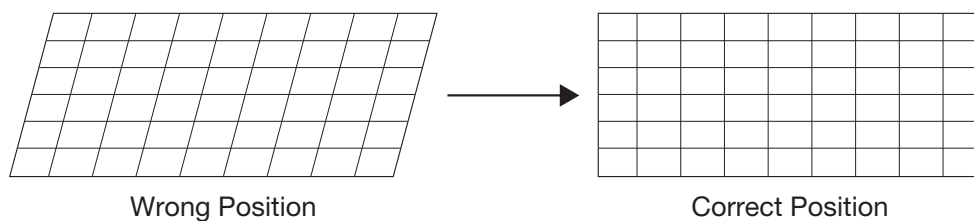

4. When the image geometry appears correct, tighten the Anamorphic Lens Set Screw (item #10) to secure the lens in place. (When viewed from the front, the rear opening on the anamorphic lens should appear as a tall, narrow oval.)



**Focus:** Finally, rotate the Focus Ring on the anamorphic lens to fine-tune the optical focus.



# 4. Operation

To display the Main Menu, press the **MENU** button on the remote control (Figure 2-5) or DHD Controller front panel (Figure 2-3).

To select a menu item, use the **▲** and **▼** buttons on the remote control or DHD Controller front panel to highlight it. Then, to confirm your selection, press **ENTER** on the remote control or DHD Controller front panel.

The VX-6000d OSD menus are arranged hierarchically, as shown in Figure 4-1.

Depending on the selected input source and signal characteristics, some menu options may not be available.

## 4.1 Using the On-Screen Menus

<b>Input Source</b>	Composite
	S-Video 1
	S-Video 2
	Component
	HD1
	HD2
	SCART
	HDMI 1 HDMI 2
<b>Aspect Ratio</b>	16:9
	4:3
	Letterbox
	VirtualWide
	Cinema
	Virtual Cinema
<b>Picture</b>	Native
	Brightness
	Contrast
	Color
	Tint
	Sharpness
<b>Input Position</b>	Noise Filter
	Left/Right
	Up/Down
	Width
	Height
	Overscan
	Overscan Mode (Zoom/Crop)
	Phase (RGB/Component/SCART signals only)
	Tracking (RGB/Component/SCART signals only)
<b>Memory Presets</b>	Recall ISF Night
	Recall ISF Day
	Recall/Save Custom
	Recall/Save THX
	Reset Custom or THX to Factory Default
<b>Information</b>	Signal
	System
	Field Service
	Manufacturing

<b>Calibration</b>	Display Color	Gain	-100, -99... <b>0</b> ... 99, 100
		Offset	(Red, Green, Blue)
		Gamma	-30, -29... <b>0</b> ... 29, 30
		Lamp	Power (180W or <b>220W</b> )
		Color Temp.	Simple (5500K, <b>6500K</b> , 7500K or 9300K)
		SatCo (BrilliantColor™)	On/Off
		RVR	<b>0</b> (fully open) or 1
		Input Image	Brightness
	Contrast		
	Color		
	Tint		
	Sharpness		
	Input Color	Gain	-32, -31... <b>0</b> ... 31, 32 (HD 1, HD 2 and Component inputs only)
		Offset	
		Chroma Delay	<b>0</b> , 1, 2 ... 7 (S-Video 1, S-Video 2 and Composite inputs only)
		Noise Filter	<b>0</b> , 1, 2 ... 63
	Save ISF Night	Back / Confirm	
	Save ISF Day		
	Copy/Paste	Copy Settings	
		Paste Settings	
	Output Shift	Left/Right	-50, -49 ... <b>0</b> ... 49, 50
		Up/Down	
		Width	
	Splash Configure	Height	-50, -49, 48 ... <b>0</b>
Owner Name			
ISF Calibrated			
ISF Other			
OSD Position	Splash Timer	5, 6, 7 ... <b>15</b> ... 59, 60	
	Splash Enable	On/Off	
	Hor. / Ver.	<b>0</b> , 1, 2 ... 100	

**Note:** Default settings appear in **bold type**.

Figure 4-1. VX-6000d OSD Menu Structure

<b>Service</b>	Test Video	Color Bars 1	
		Color Bars 2	
		Focus	
		Grey Bars	
	Input Names	Rename/Restore	
	Remote Control	Remote Code	00, 01, 02 ... <b>17</b> ... 31
		COMP Key Source	<b>Component</b> or SCART
	Display Device - Configure	Installation	Picture Orientation: Floor Front, Ceiling Front, Floor Rear or Ceiling Rear
		Lamp Info. (read-only)	Serial Number, Hours
		Diagnostics	White, Red, Green, Blue, Yellow, Cyan, Magenta
		Altitude	<b>Auto</b> / High
	Color Space	<b>Auto</b> , REC601, REC709, RGB-PC or RGB-Video	(Not available on S-Video or Composite video inputs)
	Triggers	1 / 2 / 3	
	Miscellaneous	Language	English, Français, Deutsch, Italiano, Español, Svenska, Traditional Chinese, Simplified Chinese, Português or Russian
		OSD Timer	0 (no timeout) or 5, 6, 7 ... <b>15</b> ... 60 sec.
		OSD Messages	On / Off
		Blank Screen Color	Red/Green/Blue = <b>0</b> , 1, 2, 3 ... 255
		Sidebar Color	
		Film Mode (SD sources only)	On / Off
		CUE (Chroma Upsampling Error)	On / Off
	Sync Threshold	0, 1, 2, 3, <b>4</b> ... 15	(HD 1, HD 2 and Component inputs only)
	HDMI EDID Extension	HDMI 1 / HDMI 2	<b>On</b> / Off
	Front Panel Brightness	Logo LED	0 (off), 1, 2 ... <b>31</b>
Standby LED		<b>On</b> / Off	
LCD		0 (off), 1, 2, 3 or <b>4</b>	
System Reset			

**Note:** Default settings appear in **bold type**.

**Figure 4-1. VX-6000d OSD Menu Structure (continued)**

**Main Menu** ➤ The Main Menu is the starting point for accessing all VX-6000d functions. (You must enter a passcode to access the Calibration and Service menus.)

<b>Runco Video</b>
Input Source
Aspect Ratio
Picture
Input Position
Memory Presets
Information
Calibration
Service

From the Main Menu, select Input Source to choose a video signal source.

The active source is indicated by an arrow (➡) to its left; in this example, Composite is the active source.

◀ **Input Source**

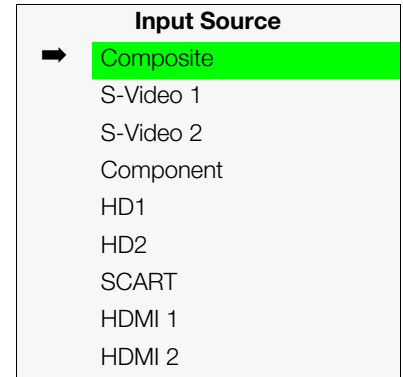

To change the aspect ratio (size and shape) of the projected image, select Aspect Ratio from the Main Menu and press **ENTER**. Select the appropriate aspect ratio for your screen size and the type of program material being viewed; refer to Table 4-1.

The currently-selected aspect ratio is indicated by a “☒” to its left; in this example, 16:9 is selected.

Note that some aspect ratios are unavailable and/or not useful with certain types of source material. The optimal setting depends on a number of factors, such as:

- The aspect ratio of the source material, as broadcast or encoded on the playback medium.
- The “display type” (16:9 or 4:3) and output resolution settings at the source component. Most modern DVD/BD players and set-top boxes have such controls.
- Viewer preference (original aspect ratio with “black bars,” or a full-screen presentation with some distortion or cropping).

◀ **Aspect Ratio**

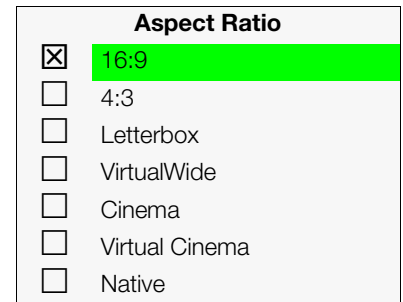



**Note**

*The aspect ratio selection is automatically saved for each input and resolution.*

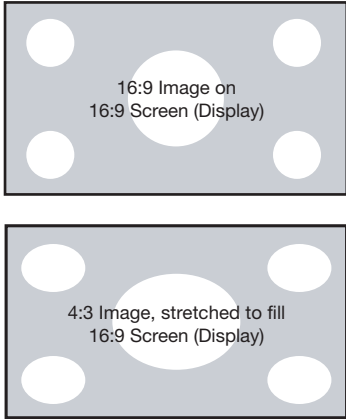
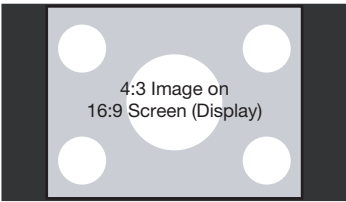
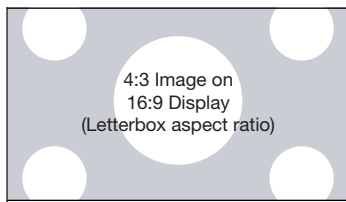
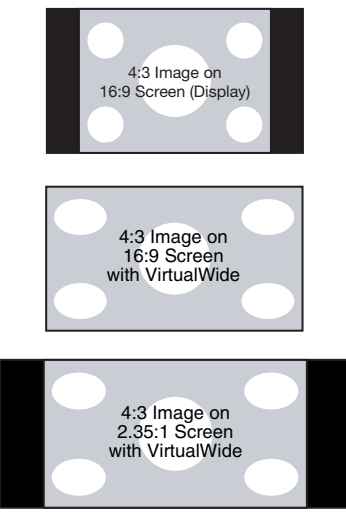
**Table 4-1. Aspect Ratio Settings**

Aspect Ratio	Remote Control Button	Description	
16:9	16:9	 <p>16:9 Image on 16:9 Screen (Display)</p> <p>4:3 Image, stretched to fill 16:9 Screen (Display)</p>	<p>Select 16:9 to view 16:9 DVDs and HDTV programs in their native aspect ratio.</p> <p>4:3 images are stretched horizontally to fit a 16:9 screen.</p>
4:3	4:3	 <p>4:3 Image on 16:9 Screen (Display)</p>	<p>Standard 4:3 scales the input signal to fit in the center of the 16:9 screen. 4:3 is the aspect ratio used by computer monitors, standard television programming and most VHS video cassettes.</p>
Letterbox	LBOX	 <p>4:3 Image on 16:9 Display (Letterbox aspect ratio)</p>	<p>Letterbox mode scales (zooms in on) a 4:3 image linearly (by the same amount on all sides) to fill a 16:9 display. Letterbox is best suited for viewing LaserDisc movies or non-anamorphic DVDs on a 16:9 screen.</p>
VirtualWide	VWIDE	 <p>4:3 Image on 16:9 Screen (Display)</p> <p>4:3 Image on 16:9 Screen with VirtualWide</p> <p>4:3 Image on 2.35:1 Screen with VirtualWide</p>	<p>VirtualWide scales a 4:3 image NON-linearly (more on the sides than in the center) to fit a 16:9 screen.</p> <p>On a 2.35:1 screen, the image is centered between black bars on either side.</p>

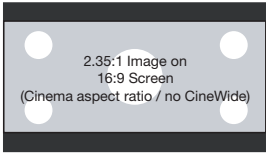
**Table 4-1. Aspect Ratio Settings (continued)**

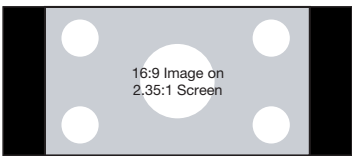
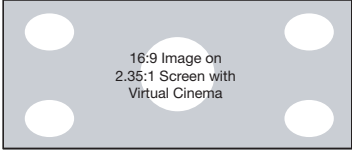
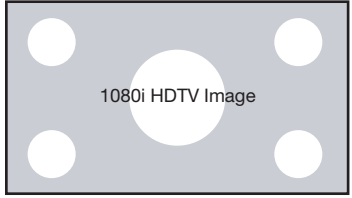
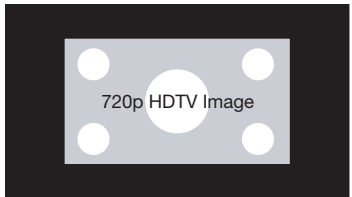
Aspect Ratio	Remote Control Button	Description	
Cinema	CINEMA	 <p>2.35:1 Image on 16:9 Screen (Cinema aspect ratio / no CineWide)</p>  <p>2.35:1 Image on 2.35:1 Screen (Cinema aspect ratio / CineWide)</p>	<p>Select Cinema to view 2.35 source material in its native aspect ratio.</p> <p>With a 16:9 screen and a non-CineWide projector (no anamorphic lens), the upper and lower portions of the screen are masked, but the geometry of the active image area is unchanged.</p> <p>With a 2.35:1 screen and a CineWide-equipped projector, the DHD Controller scales the 2.35:1 image so that the active image area fills the 16:9 chip surface, eliminating the black bars. The secondary, anamorphic lens then restores the proper geometry to the 2.35:1 image.</p>
Virtual Cinema	SVC	 <p>16:9 Image on 2.35:1 Screen</p>  <p>16:9 Image on 2.35:1 Screen with Virtual Cinema</p>	<p>A 16:9 image is scaled NON-linearly (more on the sides than in the center) to fit a 2.35:1 screen.</p> <p>Virtual Cinema is available only on CineWide-equipped projectors.</p>
Native	(none)	 <p>1080i HDTV Image</p>  <p>720p HDTV Image</p>	<p>Select Native to display the source signal in its native resolution, centered in the display area with no re-sizing or overscan.</p> <p>This means, for example, that 720p HDTV programs will display with unused pixels on all sides: 320 on the left and right sides and 180 above and below.</p> <p>With SDTV and EDTV sources, the VX-6000d scales the image horizontally to achieve a 16:9 aspect ratio.</p>

**Picture** ➤

Picture
Brightness
Contrast
Color
Tint
Sharpness
Noise Filter

Use the controls in the Picture Menu to calibrate your VX-6000d for optimum picture quality.

The VX-6000d has been designed to incorporate setup and calibration standards established by the Imaging Science Foundation (ISF). The ISF has developed carefully crafted, industry-recognized standards for optimal video performance and has implemented a training program for technicians and installers to use these standards to obtain optimal picture quality from Runco video display devices. Accordingly, Runco recommends that setup and calibration be performed by an ISF certified installation technician.

All signal types require separate processing. Therefore, you need to calibrate each DHD Controller input separately.



**Note**

*When you change a picture quality setting, save the change to a preset afterwards. Otherwise, the change will be lost when a different input is selected. (Picture quality settings are saved for each input separately.) For information about saving settings, refer to **Memory Presets** on page 63.*

Although it may be possible to obtain satisfactory picture quality using the naked eye and regular program material, Runco recommends using an external test pattern source (Ovation Multimedia, Digital Video Essentials or AVIA test DVD or equivalent) for best results.

Connect your test pattern source to the input that you are calibrating and proceed as follows. **Perform the adjustments in the order listed here.**

**Brightness:** On your external test pattern source, select a PLUGE pattern. (PLUGE is an acronym for “Picture Line-Up Generation Equipment.”) Figure 4-2 shows a typical PLUGE pattern.

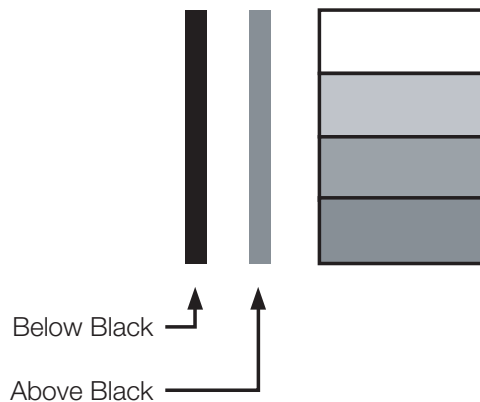

**Figure 4-2. Typical PLUGE Pattern for Adjusting Brightness**



PLUGE patterns vary but generally consist of some combination of black, white and gray areas against a black background. The example above includes two vertical bars and four shaded boxes.

Select Brightness from the Picture menu and press **ENTER**. Adjust the brightness so that:

- The darkest black bars disappear into the background.
- The dark gray areas are barely visible.
- The lighter gray areas are clearly visible.
- The white areas are a comfortable level of true white.
- The image contains only black, gray and white (no color).

**Contrast:** On your external test pattern source, select a stepped, gray-bar pattern like the one shown in Figure 4-3.

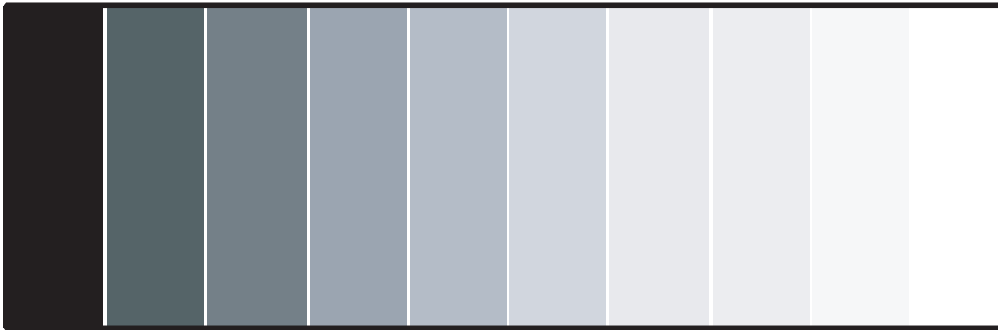

**Figure 4-3. Typical Gray Bar Pattern for Adjusting Contrast**

Select Contrast and press **ENTER**. Adjust the contrast to a point just below which the white rectangle starts to increase in size.



*Brightness and contrast controls are interactive. A change to one may require a subtle change to the other in order to achieve the optimum setting.*

**Color Saturation:** On your external test pattern source, select a color bar pattern like the one shown in Figure 4-4.

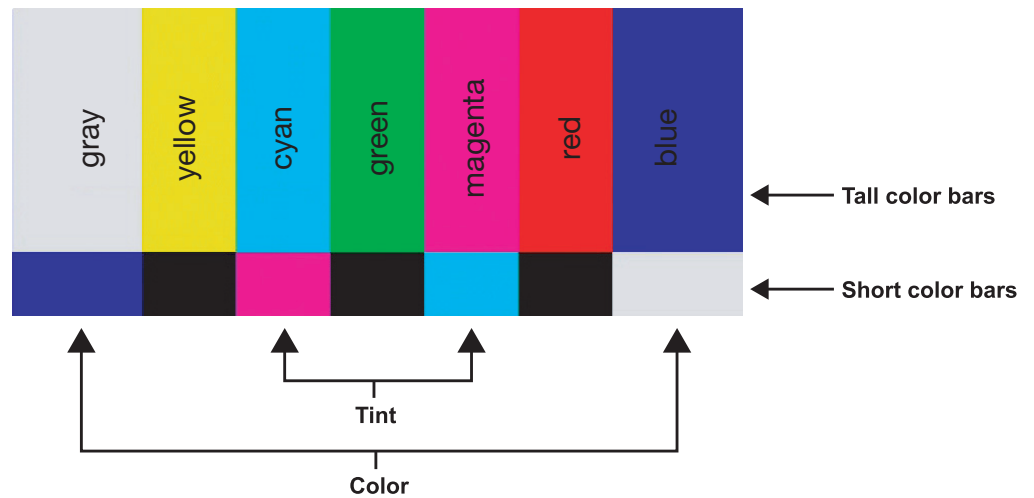

**Figure 4-4. Typical Color Bar Pattern for Adjusting Color Saturation and Tint**

1. Press the **MENU** button on the remote control or DHD Controller front panel.
2. Select Service from the Main Menu and press **ENTER**.
3. Enter the Service menu passcode.
4. Select Display Device from the Service menu and press **ENTER**.
5. Press **ENTER** again to select Configure.
6. Select Diagnostics and press **ENTER**.
7. Select Blue from the Diagnostics menu, then press **ENTER** to display only the blue color channel.
8. Press **RETURN** (or **MENU**) repeatedly to return to the Main Menu.
9. Select Picture from the Main Menu and press **ENTER**.
10. Select Color from the Picture menu and press **ENTER**.

11. Adjust the color saturation level until the outermost (gray and blue) color bars appear to be a single shade of blue:

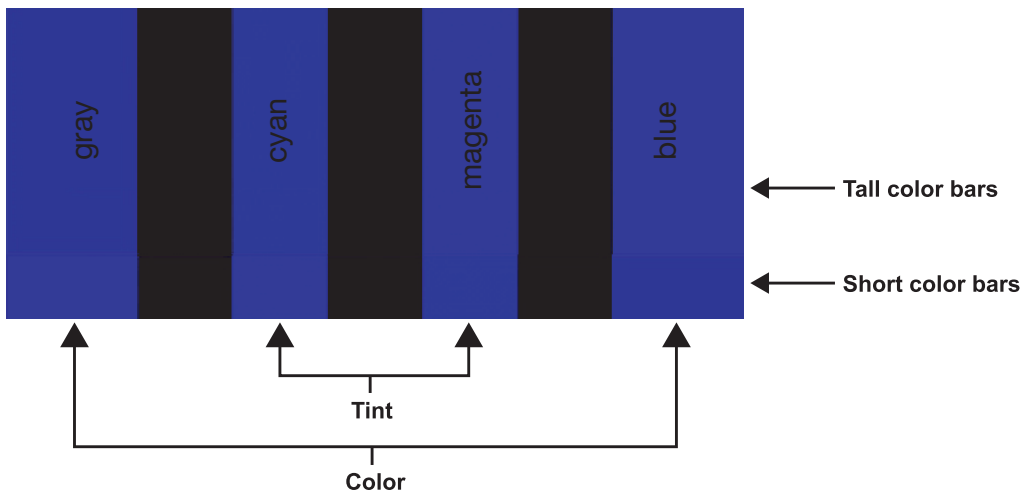

**Tint:** Tint or “hue” is essentially the ratio of red to green in the color portion of the image. When tint is decreased, the image appears redder; when it is increased the image appears greener.

To adjust the tint, enable “blue only” display mode in the Diagnostics menu, as you would for adjusting color saturation (refer to the previous section, **Color Saturation**).

Select Tint from the Picture menu and press **ENTER**. Adjust the tint level until the cyan and magenta color bars (on either side of the green bar) appear to be a single shade of blue.



**Note**

*Like the brightness and contrast controls, the color and tint controls are interactive. A change to one may require a subtle change to the other in order to achieve the optimum setting.*

**Sharpness:** “Sharpness” is the amount of high-frequency detail in the image. To adjust sharpness, select Sharpness from the Picture menu and press **ENTER**. On your external test pattern source, select a pattern like the one shown in Figure 4-5. Adjust as needed, looking for white edges around the transitions from black to gray and differently-sized lines in the “sweep” patterns at the top and bottom. Lower the sharpness setting to eliminate them.

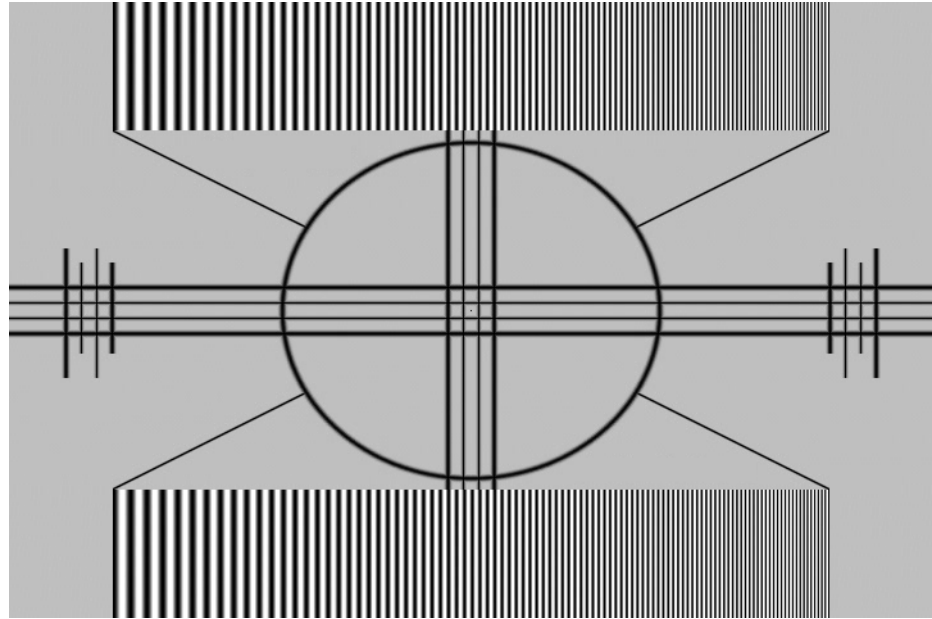

**Figure 4-5. Typical Test Pattern for Adjusting Sharpness**

**Noise Filter:** To apply noise filtering to the input signal, select Noise Filter from the Picture menu. The Noise Filter is useful for clearing up noisy images from 480i video sources.

Use the left- or right-arrow buttons to select the desired amount of noise reduction, keeping in mind that higher settings (which reduce high frequencies) may also “soften” the image.

Use the controls in the Input Position Menu to fine-tune the aspect ratio and image position for the current source.



**Note**

*The input position settings are automatically saved for each input and resolution.*

**Left/Right:** Select Left/Right from the Input Position menu to shift the projected image horizontally. Press ► to shift the image to the right; press ◀ to shift it to the left.

**Up/Down:** Select Up/Down from the Input Position menu to shift the projected image vertically. Press ► to shift the image upward; press ◀ to shift it downward.

**Width:** Select Width from the Input Position menu to change the projected image width. Press ► to increase the width; press ◀ to decrease it.

**Height:** Select Height from the Input Position menu to change the projected image height. Press ► to increase the height; press ◀ to decrease it.

**Overscan/Overscan Mode:** Overscan pushes the outside edge of the active picture area of the video signal out beyond the edge of the display area.

Some television programs are produced based on the assumption that older television sets may not display the outer edges of the broadcast picture area. Overscan effectively trims away these inactive, outer edges and enlarges the remaining portion of the image to fill the display area.

For HDTV, DVDs and other video sources, Overscan is generally not necessary or desirable.

This control defines the amount of overscan applied to the image. The range is from 0 to 20. There are two overscan modes:

- In **Crop** mode, each increment adds a mask at the top, bottom, left and right edges of the source image equal to 0.5% of the displayed horizontal resolution (1% total). A setting of 10, for example, crops the image 5% on all sides or 10% total.
- In **Zoom** mode, each increment adds a factor to the scaling of the source image so that the vertical and horizontal resolutions are 100% plus 1% increments of the size determined by the aspect ratio function. A setting of 10, for example, zooms in on the image 5% on all sides or 10% total.

Figure 4-6 illustrates the effect of each overscan mode setting.

◀ **Input Position**

Input Position
Left/Right
Up/Down
Width
Height
Overscan
Overscan Mode
Phase
Tracking

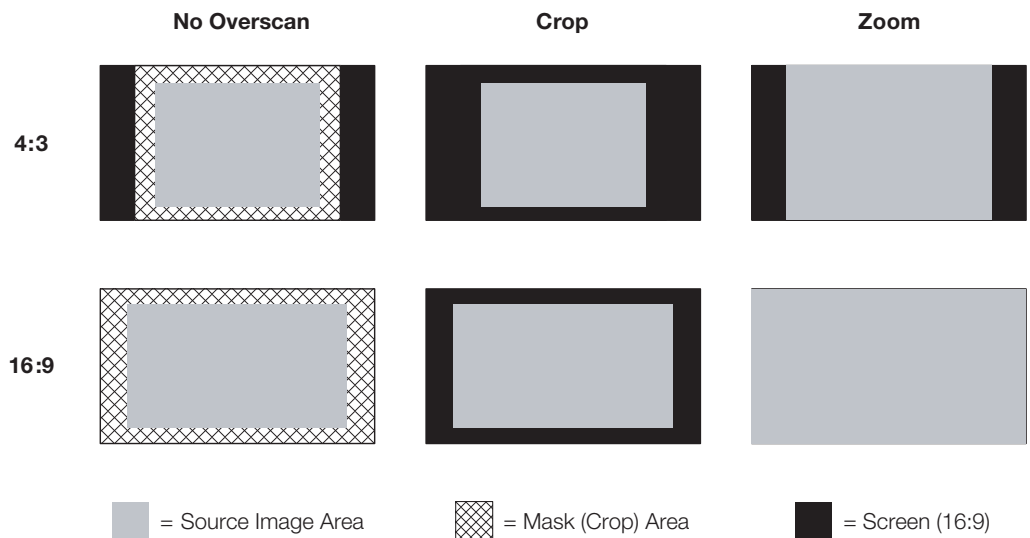

**Figure 4-6. Overscan Modes**

**Phase (RGB, Component or SCART sources):** This control adjusts the phase of the pixel sampling clock relative to the incoming signal. Adjust the phase when an RGB, Component or SCART image still shows shimmer or “noise” after Tracking has been optimized.



**Tip**

*Adjust the Phase after adjusting Tracking (see below).*

For best results, use a good test pattern such as a smooth gray consisting of a clear pattern of black and white pixels, or a similar “half on, half off” graphic image. Adjust the slider until the image stabilizes and each pixel is clearly defined. You may notice that you can stabilize the image at more than one point. Use either setting in such cases.

**Tracking (RGB, Component or SCART sources):** Tracking determines the frequency of the pixel sampling clock, indicated by the number of incoming pixels per line, so that all pixels generated by a particular source are sampled.

Steady flickering or several soft vertical stripes or bands across the entire image indicates poor pixel tracking. Proper pixel tracking helps ensure that the image quality is consistent across the screen, that aspect ratio is maintained and that pixel phase (see above) can be optimized.

For each input, the VX-6000d lets you save image quality settings as presets that you can recall at a later time. You can create up to four presets per input and display mode (resolution and frame rate).

The DHD Controller stores the following display modes in each memory preset:

- 480i
- 480p
- 576i
- 576p
- 720p/24 Hz
- 720p/25 Hz
- 720p/30 Hz
- 720p/50 Hz
- 720p/60 Hz
- 1080i/50 Hz
- 1080i/50 Hz (Australia)
- 1080i/60 Hz
- 1080p/24 Hz
- 1080p/25 Hz
- 1080p/30 Hz
- 1080p/50 Hz
- 1080p/60 Hz

Use the Memory Presets menu to recall saved image presets, or to save image settings in the “Custom” or “THX” memory location. The currently-selected preset is indicated by a “➡” to its left; in the example shown here, ISF Night is selected.

You should save changes to any of the following settings to a preset; otherwise they will be lost when a new input source or resolution is selected:

- Brightness
- Contrast
- Color saturation
- Tint
- Sharpness
- Gamma
- Lamp Settings
- Color temperature and white balance

To select a memory preset, press ▲ or ▼ to highlight it and press **ENTER**.

To save the settings for the current input and display mode to the Custom or THX memory preset, select it, press ◀ or ▶ to highlight Save and press **ENTER**.

◀ **Memory Presets**

Memory Presets			
➡	ISF Night		
	ISF Day		
	Custom	Save	Reset
	THX	Save	Reset



**Note**

*To save the settings for the current input and display mode to the ISF Night or ISF Day memory preset, select Save ISF Night or Save ISF Day from the Calibration menu (refer to **Save ISF Night/Save ISF Day** on page 67).*

To reset the Custom or THX memory preset to its factory-default state, select it, press ◀ or ▶ to highlight Reset and press **ENTER**.

**Information** ➤

Information
Signal
System
Field Service
Manufacturing

**Signal / System:** Select Information from the Main Menu, then choose either Signal or System to display information about the current input signal (resolution, frequency, type et cetera) and installed firmware versions, as well as other information that uniquely identifies your DHD Controller and display device.

Should you ever need to contact Runco Technical Support, this information will help them answer your questions or resolve product performance issues.

Signal	
Input Source	HDMI 1
Signal Format	1080p/60
Input Resolution	1920x1080
Vertical Freq	59.94 Hz
Horizontal Freq	67.500 kHz
Pixel Clock	148.500 MHz
Color Space	REC709
Sync Type	Separate
Memory Preset	ISF Night

System	
Model	DHD3
Display Name	VX-6000d
Output Resolution	1920x1080
Serial Number	00000000
Boot Version	3.0
Firmware Version	3.4
Micro Version	3.3

**Field Service / Manufacturing:** The Field Service and Manufacturing menus are password-protected and intended for use only by Runco service personnel and factory technicians.

**Calibration** ➤

Calibration
ISF Settings
Display Color
Input Image
Input Color
Save ISF Night
Save ISF Day
Copy/Paste
Output Shift
Splash Configure
OSD Position

Use the Calibration menu to perform advanced picture quality adjustments. **This menu should be used by ISF-certified technicians only.**



**Note**

*You must enter a passcode to access the Calibration menu for the first time after turning on the system.*

To recall the ISF Night or ISF Day settings, select “ISF Night” or “ISF Day” from the Memory Presets menu (see page 63) or use the corresponding remote control buttons.

**Display Color:** Use the Display Color settings to adjust the color balance at the DHD Controller output. These settings are saved independently for each input and display mode.

- **Gain:** Use the Gain controls to correct color imbalances in the bright areas of the image. A good way to do this is to use a test pattern consisting mostly of solid white areas, such as an 80 IRE “window” pattern. If the white areas contain traces of red (Pr), green (Y) or blue (Pr), decrease the Gain for that color.
- **Offset:** Use the Offset controls to correct color imbalances in the dark areas of the image. A good way to do this is to use a test pattern consisting mostly of dark gray areas, such as a 30 IRE “window” pattern. If the gray areas contain traces of red (Pr), green (Y) or blue (Pr), decrease the Offset for that color.



- **Gamma:** Select Gamma from the Display Color menu to choose a de-gamma curve. Used correctly, the Gamma control can improve contrast while maintaining good details for blacks and whites. If excess ambient light washes out the image and it becomes difficult or impossible to see details in dark areas, lower the gamma setting to compensate. This improves contrast while maintaining good details for blacks. Conversely, if the image is washed out and unnatural, with excessive detail in black areas, increase the setting.
- **Lamp:** Select Lamp from the Display Color menu to adjust the projector lamp brightness.
  - **Power (180W or 220W):** To supply a constant wattage to the lamp, select Power from the Lamp menu to set the lamp power level. You can choose to run the lamp as bright as possible (220 watts; this is the default setting) or you can choose a lower setting (180 watts). Generally, lower lamp output prolongs the life of the lamp, but decreases brightness.
- **Color Temp.:** Select Color Temp. from the Display Color menu to adjust the color temperature. Color temperature establishes the “color of gray” by adjusting the 75% white point to various color points.

**What are “color points?”** A “color point” is an x/y coordinate pair that defines a color’s location on the standard CIE chromaticity graph, shown in Figure 4-7. (CIE stands for “Commission Internationale de l’Éclairage” (International Commission on Illumination), the organization responsible for color measurement and management standards.)

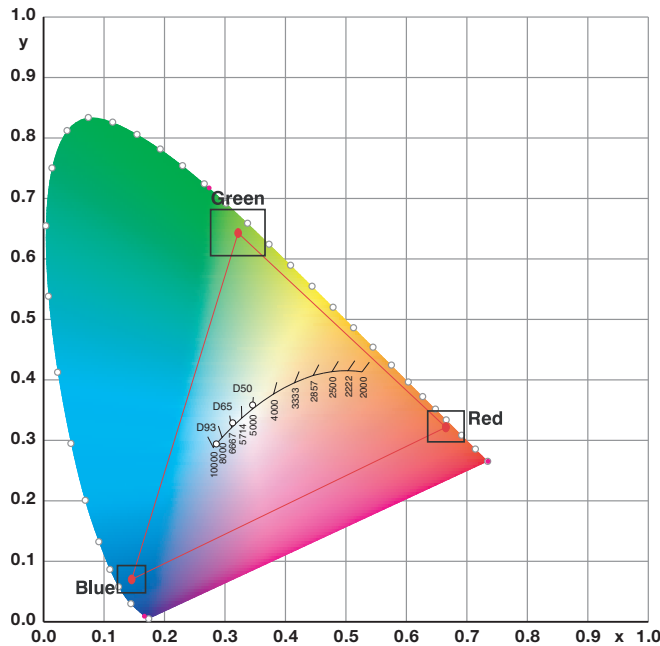

**Figure 4-7. CIE 1931 Chromaticity Diagram**

- **Simple:** Select Simple mode from the Color Temp. menu (with the VX-6000d, this is the only choice) to choose one of four color temperature presets: 5500K, 6500K, 7500K and 9300K. The default setting, 6500K, is appropriate for most situations. Higher settings produce a “bluer” picture; lower ones impart a reddish hue to the image.

Table 4-2 lists the x- and y-coordinates for each color temperature preset.

**Table 4-2. Color Temperature Presets and Associated Color Points**

Color Temperature Preset	Associated x/y Values	
	x	y
5500K	0.332	0.348
6500K	0.313	0.329
7500K	0.299	0.315
9300K	0.284	0.298

- **SatCo (BrilliantColor™):** Select SatCo (BrilliantColor™) from the Display Color menu to enable (On) or disable (Off) BrilliantColor processing, which improves brightness in grays and secondary colors.
- **RVR:** Use the RVR control to increase or decrease the Reflectance Volume Regulation setting. RVR lets you control the aperture or iris size (the physical opening through the lens; similar to an “f-stop” on a camera). Doing so allows you to optimize brightness and contrast according to the amount of ambient light in the viewing area.

Use the lower setting (0 = fully open) for rooms with a lot of ambient light. Use the higher setting for more “theater-like” viewing conditions (little or no ambient light).

**Input Image:** The Input Image controls are functionally similar to those in the Picture menu (refer to page 56), but are accessible only by entering the Calibration menu passcode.



**Note**

*The Input Image settings establish the “zero point” for the Picture menu settings, whose values represent offsets from the Input Image settings. For example, if you set Brightness to 10 in this menu, setting Brightness to 10 in the Picture menu results in an actual setting value of 20 (10+10).*

**Input Color:** The Input Color controls are similar to those in the Display Color menu (see above), but adjust the color balance of the incoming signal. These settings are also saved independently for each input and display mode.

- **Gain/Offset (HD1, HD2 and Component/SCART inputs only):** These controls operate similarly to those in the **Display Color** menu (described on page 64), but affect the Y, Pb and Pr signal components rather than the red, green and blue channels.
- **Chroma Delay:** use the Chroma Delay control to correct a mis-aligned image from a Composite or S-Video source. Chroma delay in an image causes color shifts to occur to the left of the vertical edge transitions, producing artificial shadows or a “halo” effect. If necessary, adjust this setting to eliminate them.
- **Noise Filter:** To apply noise filtering to the input signal, select Noise Filter from the Input Color menu. The Noise Filter is useful for clearing up noisy images from 480i video sources.

Use the left- or right-arrow buttons to select the desired amount of noise reduction, keeping in mind that higher settings (which reduce high frequencies) may also “soften” the image.

**Save ISF Night/Save ISF Day:** Whenever you make a change to the ISF settings, you should always save it. Select Save ISF Night or Save ISF Day from the Calibration menu to do this.

**Copy/Paste:** You can copy and paste settings from one memory location to another. This gives you a convenient starting point for creating a new preset based on an existing one, to make the calibration process less time-consuming.

For example, you can use the Copy/Paste feature to:

- Apply settings from HDMI 1 to HDMI 2, or from HD1 to HD2.
- Calibrate an input for 720p source signals, then use those settings for 1080i sources.
- Duplicate ISF Night settings for a given source and signal format and save them in the Custom memory preset.

To use this feature, select Copy/Paste from the Calibration menu.

- **Copy Settings:** Select Copy Settings from the Copy/Paste menu to place the settings for the current input source, signal format (resolution and frame rate) and memory preset onto a “clipboard,” which is a temporary memory location. When you do, the message “Settings Copied” briefly appears on-screen. The Copy/Paste menu then re-appears, indicating the source of the copied settings.

Copy/Paste	
Copy Settings	
Paste Settings	
Copied From:	
Input Source	HDMI 1
Signal Format	1080p/60
Memory Preset	ISF Night



**Note**

*Copied settings are not retained after a power cycle.*

- **Paste Settings:** To apply the settings on the clipboard to a different input source, signal format and/or memory preset, do **any or all** of the following:
  - Switch to another DHD Controller input (for example, from HD1 to HD2).
  - Change the output signal format at the source (for example, from 720p/60 to 1080i/60).
  - Switch to another Memory Preset (for example, from ISF Night to Custom).

Then, select Paste Settings from the Copy/Paste menu. **If you want to keep these new settings, you must save them!** (Refer to **Save ISF Night/Save ISF Day** on page 67 or **Memory Presets** on page 63.)

**Output Shift:** The controls in the Output Shift menu are similar to those in the Input Position menu, except that they change the characteristics of the output signal. These settings are saved independently **for each aspect ratio**.

**Splash Configure:** Use the Splash Configure menu to control the appearance and behavior of the “splash” screen that appears on the display upon power-up.

- **Owner Name/ISF Calibrated/ISF Other:** You can have the VX-6000d display the owner’s name, your name, the phrase “ISF Calibrated” and/or any other string, up to 30 characters in length.

Use the up or down cursor button to select a character. Use the right and left cursor buttons to change the cursor position. Press **MENU** when you have finished entering text.

- **Splash Timer:** When you turn on the VX-6000d, it projects a welcome screen with the Runco and ISF logos, along with the personalized information you enter as described above. Select Splash Timer from the Splash Configure menu to set the amount of time for which this screen appears. The range is from 5 to 60 seconds, in one-second increments. Press ◀ or ▶ to set the timer, then press **MENU**.

- **Splash Enable:** When you have finished customizing the splash screen, select Splash Enable from the Splash Configure menu. Then, select On and press **ENTER**.

**OSD Position:** To adjust the position of the OSD, select OSD Position from the Calibration menu and press **ENTER**.

Press ▲ or ▼ to select “Hor.” or “Ver.” Then, press ◀ or ▶ to change the position.

**Service** ➤ Use the Service menu to access advanced display configuration settings. **This menu should be used by ISF-certified technicians only.**

Service	
Test Video	
Input Names	
Remote Control	
Display Device	
Color Space	
Triggers	
Miscellaneous	
Sync Threshold	
HDMI EDID Extension	
Front Panel Brightness	
System Reset	



**Note**

*You must enter a passcode to access the Service menu for the first time after turning on the system.*

**Test Video:** Select Test Video from the Service Menu to access the internal test patterns on the VX-6000d. Four patterns are available: Horizontal Ramp, Vertical Ramp, Color Bars 1 (solid bars) and Color Bars 2 (SMPTE “checkerboard” pattern).

Press **MENU** to exit test pattern mode.

Input Names	
	Restore
Composite	Composite
S - Video 1	S-Video 1
S - Video 2	S-Video 2
Component	Component
HD 1	HD 1
HD 2	HD 2
SCART	SCART
HDMI 1	HDMI 1
HDMI 2	HDMI 2

**Input Names:** You can give each DHD Controller input a descriptive name. For example, you may want to change the default input name to the type of source component connected to it: “VCR,” “DVD,” “Laptop” et cetera. Input names can be up to 12 characters long.

To edit an input name, select Input Names from the Service menu. Press ▲ or ▼ to select an input and press **ENTER**. Use the ▲ or ▼ buttons to change a character; press ◀ or ▶ to select a character to change. When you have finished editing the input name, press **ENTER** or **MENU**.

To restore the default input name, press ▼ repeatedly to highlight that input name in the “Restore” column. Then, press **ENTER**.

**Remote Control:** Select Remote Control from the Service menu to change the following settings related to remote control operation.

- **Remote Code:** Select Remote Code from the Remote Control menu to set the infrared (IR) code set to which the VX-6000d will respond. By default, it is set to 17. You can change this setting if either:
  - Another device in the theater (a DVD player, for example) is responding to commands from the VX-6000d remote control (Figure 2-5) in ways that are unpredictable or undesirable.
  - You have multiple DHD Controllers and want to control them independently, as opposed to broadcasting commands from a single remote to all of them. In this scenario, you can use multiple remotes programmed to use different IR codes. Or, you can use a single remote and change the IR code as needed to address a specific DHD Controller.



**Tip**

*Use the DHD Controller front-panel keypad to change the IR code to which the controller will respond. Then, change the code sent by the remote to match as described below.*

When you change a remote code on the VX-6000d, you must re-program the VX-6000d remote control to send that same code. To do this:

1. Press and hold the **LIGHT** button on the remote control for approximately three seconds, or until the LED on the remote lights solid red.
2. Enter a new two-digit code between 00 and 31 inclusive. Include a leading zero for single-digit codes; for example, enter 9 as "09."
3. The LED turns off to confirm the code change. If you enter an invalid code, the LED flashes for three or four seconds. Try again, entering a valid code.

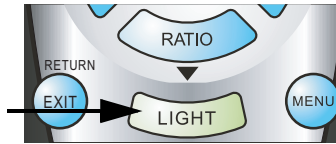

- **COMP Key Source:** Select COMP Key Source from the Remote Control menu to assign the COMP remote control button to either the Component or SCART input.

**Display Device - Configure:** The options in the Display Device - Configure menu allow you to change the picture orientation, perform lens adjustments or access other, display-device specific functions.

- **Installation – Orientation:** Select Installation from the Display Device - Configure menu, then select Orientation to change the picture orientation to suit the method of installation (Floor Front, Floor Rear, Ceiling Front or Ceiling Rear).
- **Lamp Info.:** Select Lamp Info. from the Display Device - Configure menu to obtain information about the currently-installed lamp: its serial number and number of hours in use.
- **Diagnostics:** Select Diagnostics from the Display Device - Configure menu, then select Red, Green, Blue, Yellow, Cyan or Magenta to display only that color channel (simulating a filter of that color). This can be useful for calibration or measurement purposes.

To restore the normal picture (all colors), select White.

- **Altitude:** Select Altitude from the Display Device - Configure menu to control the operation of the projector's cooling fan.

In most cases, the default setting (**Auto**) will maintain the correct operating temperature. If the lamp frequently turns off due to overheating, or in certain high-altitude operating environments, you may need to change this setting to **High**.

**Color Space:** Select Color Space from the Service menu to choose the color space of the source signal for HDMI, RGB, and component connections.

- The default setting, **Auto**, functions as follows:
  - **HDMI:** If the Auxiliary Video Information (AVI) infoframe contains color space and/or range data, the VX-6000d uses that information. Otherwise, for RGB sources, the VX-6000d uses the **RGB-Video** color space. For component SDTV and EDTV resolutions, **REC601** is used. For other component video resolutions, **REC709** is used.
  - **RGB:** If Hsync or Vsync signals are present, the VX-6000d uses the **RGB-PC** color space. Otherwise, **REC601** is used for SDTV and EDTV sources, and **REC709** for all other sources.
  - **Component:** For SDTV and EDTV resolutions, the VX-6000d uses the **REC601** color space. For all other resolutions, REC709 is used.

In most cases, the **Auto** setting determines the correct color space to use. If it does not, you can force the VX-6000d to use a specific color space. Choose one of the following:

- **REC709** sets the color space matrix to that defined in ITU-R BT.709.
- **REC601** sets the color space matrix to that defined in ITU-R BT.601.
- **RGB-PC** uses RGB color space and sets black at 0,0,0 RGB and white at 255,255,255 RGB, assuming an 8-bit image.
- **RGB-Video** uses RGB color space and sets black at 16,16,16 RGB and white at 235,235,235, assuming an 8-bit image, to correspond to the luminance values defined in digital component standards.

**Triggers:** Select Triggers from the Service menu to configure the 12-volt trigger outputs. You can assign one or more trigger outputs to each aspect ratio. Those triggers are then activated by selecting that aspect ratio.

If you are using the VX-6000d with a projector is equipped with the Runco CineWide with AutoScope system, assign at least one trigger output (the same one to which the lens motor is connected) to the Cinema and Virtual Cinema aspect ratios.

**Miscellaneous:** Select Miscellaneous from the Service menu to set the following options:

- **Language:** Select Language from the Miscellaneous menu and press the up- or down-arrows to select the OSD Language (English, Français, Deutsch, Italiano, Español, Svenska, Traditional Chinese, Simplified Chinese, Português or Russian).
- **OSD Timer:** Select OSD Timer from the Miscellaneous menu to set the OSD Timer, which controls how long the menus remain on-screen after selecting them. Select from 5 to 60 seconds, in one-second increments. Or, set the timer to 0 (disabled) if you want the menus to remain on-screen indefinitely.
- **OSD Messages:** When you select a new aspect ratio, input source or memory preset, the DHD Controller briefly displays an on-screen message confirming your new selection. To prevent the display of these messages, select OSD Messages from the Miscellaneous menu to and set it to Off.
- **Blank Screen Color:** Select Blank Screen Color from the Miscellaneous menu to select the color that appears when no incoming signal is present. The range is from 0 to 255 inclusive for each color component (red, green and blue).
- **Sidebar Color:** Select Sidebar Color from the Miscellaneous menu to change the color of the inactive image area. The range is from 0 to 255 inclusive for each color component (red, green and blue). The inactive image area is on either side of the active image area when using the 4:3 aspect ratio.
- **Film Mode:** Use Film Mode to smooth out moving images from interlaced, standard-definition (SD) sources. In most cases, the VX-6000d detects the proper “pull-down” rate and vertical frequency. However, if your source is jittery and/or tearing you may want to enable Film Mode to ensure stable processing for that source.
- **CUE (Chroma Upsampling Error) Correction:** Some DVD players use MPEG decoders that do not correctly “upsample” the 4:2:0 format chroma information on the DVD to the 4:2:2 or 4:4:4 format required by the video encoder of the display device.

This so-called “chroma bug” sometimes causes streaky or spiky horizontal lines running through the chroma channel. It is most noticeable in static, interlaced scenes and on diagonal edges (especially red ones). Set CUE to On to correct this issue.

**Sync Threshold:** Select Sync Threshold to adjust the threshold at which negative pulses on the component video green/luma channel are interpreted to be sync pulses.

Sync Threshold adjustment is occasionally necessary when a DVD player or HDTV source signal drops “below black” (for example, during scenes with explosions or when subtitles are present) and causes the display device to temporarily lose sync. If the sync level from the source is persistently too low, the display device won’t sync with the source at all.

The range is from 0 (approximately 60 millivolts (mV)) to 15 (approximately 256 mV).

**HDMI EDID Extension:** Extended display identification data (EDID) is a data structure provided by a display device to describe its capabilities to a graphics card. It is what enables a modern personal computer to know what kind of monitor is connected.

Some modern display devices provide more information via EDID than others, in the form of “extensions.” Some computer graphics cards do recognize or properly interpret this extended EDID information.

Select HDMI EDID Extension from the Service menu to specify whether or not the EDID extensions from the display device are passed through to the sources connected to the HDMI 1 or HDMI 2 inputs. By default, the extensions are on. Change these settings only if HDMI EDID incompatibility issues arise.

**Front Panel Brightness:** Select Front Panel Brightness from the Service menu to adjust the brightness of the front-panel LED and LCD status indicators.

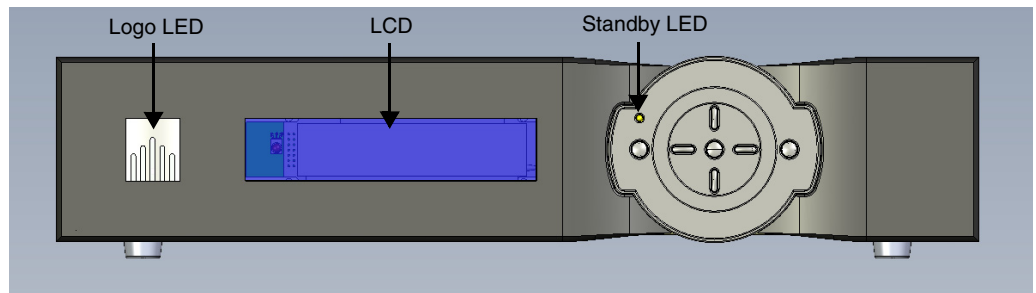

- **Logo LED:** Select Logo LED from the Front Panel Brightness menu to adjust the brightness of the large, illuminated logo on the left side of the display. The range is from 0 (off) to 31.
- **Standby LED:** Select Standby LED from the Front Panel Brightness menu to change the behavior of the front-panel STANDBY indicator LED. When set to ON, the LED lights amber when the system is in standby mode; otherwise, it is off. When set to OFF, the LED is always off.
- **LCD:** Select LCD from the Front Panel Brightness menu to adjust the brightness of the front-panel LCD. The range is from 0 (off) to 4.

**System Reset:** To reset ALL controller settings (including image settings) back to their factory defaults, choose System Reset from the Service menu.

A confirmation message appears. Select Yes to continue with the reset or select No to cancel.



**Caution**

***This action is not undoable. Proceed with caution!*** Before you perform a System Reset, save your “Custom” Memory Presets (page 63) and ISF Day/Night Memory Presets (page 67).



# 5. Maintenance and Troubleshooting

The lamp should be replaced when it reaches the end of its life (typically 2000 hours), or sooner if a noticeable degradation in brightness occurs. Contact your Runco dealer to obtain a replacement lamp.

## 5.1 Lamp Replacement

1. Turn off the projector and unplug the power cord. Allow the projector to cool down for approximately 45 minutes prior to removing the lamp assembly for replacement.
2. Loosen the two captive Lamp Cover screws on the side of the projector and remove the cover.

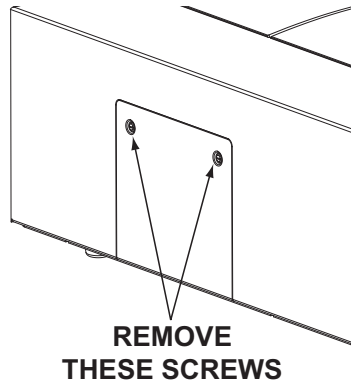

3. Remove the three Phillips round-head lamp assembly mounting screws. These are identified by arrows pointing to them on the lamp housing.
4. Grasp the lamp assembly handle and pull gently, removing the lamp module from the projector housing.
5. Install the new lamp module. Secure it in place with the three screws that you removed in Step 3.
6. Replace the lamp cover and re-tighten the two Lamp Cover screws.
7. Re-connect the AC power cord to the projector.
8. Reset the Lamp Hour counter. To do this, press and hold the **ENTER**, **DOWN** and **RIGHT** buttons on the projector rear-panel keypad (see Figure 2-2) simultaneously. Then, press the **ON** button. When you do, "**LAMP 0000H**" appears on-screen to confirm the counter reset.

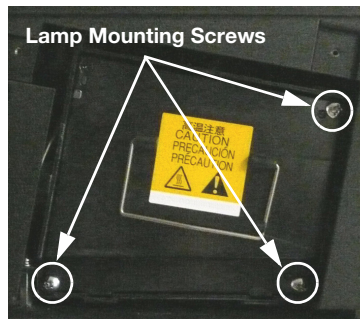

### Note

Always reset the Lamp Hour counter when you replace the lamp. Do this **only** if you have just installed a new lamp. This will ensure that number of hours logged on the lamp is accurate.

## 5.2 Lens Replacement

Figure 5-1 shows the VX-6000d lens assembly.

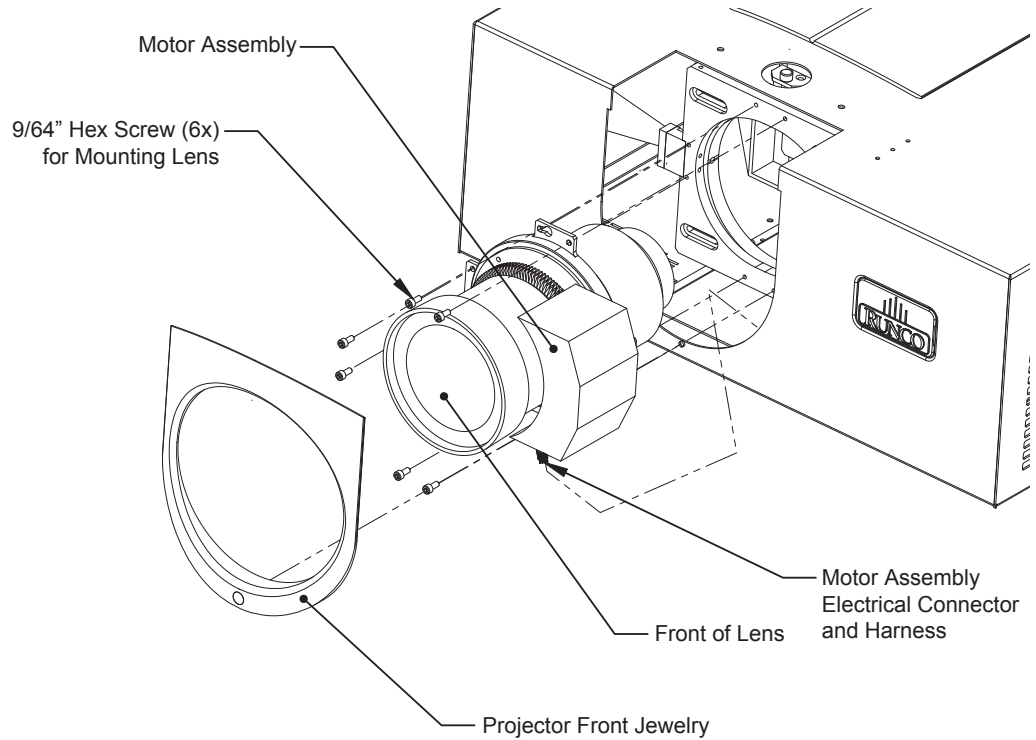

**Figure 5-1. VX-6000d Lens Assembly Exploded View**



**Note**

**Only trained, authorized Runco dealers should attempt to remove or replace a lens. Please read this procedure carefully before doing so.**

*Lens replacement is normally performed at the Runco factory. Field replacement of lenses is generally only required if the projector is re-installed in a new location or the lens has been damaged.*

1. Remove the Projector Front Jewelry by loosening the captive #2 Phillips screw below the lens.



2. Locate and unplug the Motor Assembly Connector. Note the connector orientation for when you install the new lens.

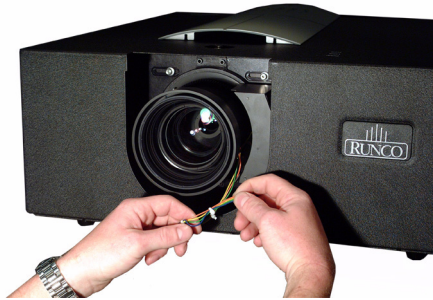

3. Locate the six 9/64" Hex Mounting Screws (two each at 12 o'clock, 9 o'clock and 6 o'clock).
4. Remove the six Mounting Screws while supporting the Lens Assembly; Lens and Motor Assembly are now free.

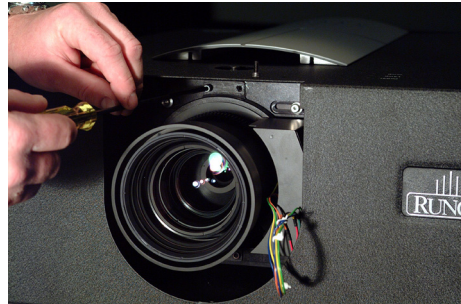

5. Remove the Lens and Motor Assembly by pulling forward and to the left in order to clear the Projector chassis with the Motor Assembly.



6. **Install New Lens Assembly:** Repeat Steps 1 through 5 in reverse order.

**Caution**

*Make sure to route the wire harness in its original position and away from the moving lens stages and Motor Assembly, to prevent unexpected disconnection or lens damage.*

## 5.3 Troubleshooting Tips

Table 5-1 provides some general guidelines for troubleshooting problems you may encounter with the VX-6000d.

If you encounter an issue not described here or in Section 3 (refer to **Installation Considerations** on page 20), or if the suggested solutions fail to resolve the problem, please contact your Runco dealer or Runco Technical Support.

**Table 5-1. Troubleshooting Chart**

Symptom	Possible Cause(s)	Solution
The projector does not turn on after initial installation. The power LED on the front of the DHD Controller lights red after you press the power button.	<ul style="list-style-type: none"> <li>The VX-6000d is not plugged in or the AC outlet is not active.</li> <li>The serial connection from the DHD Controller to the VX-6000d is incorrect.</li> <li>The remote control batteries have run out.</li> </ul>	<ul style="list-style-type: none"> <li>Ensure that the VX-6000d is plugged in and that the AC outlet is active.</li> <li>Ensure that the <b>Display Control</b> (RS-232) output from the DHD Controller is properly connected to the <b>RS-232</b> port on the VX-6000d (see Figure 3-10).</li> <li>Replace the batteries.</li> </ul>
The projector and DHD Controller are both on, but there is no picture and on-screen menus do not appear.	<ul style="list-style-type: none"> <li>Faulty or incorrect video connection between the DHD Controller and the VX-6000d.</li> </ul>	<ul style="list-style-type: none"> <li>Ensure that the HDMI output from the DHD Controller is properly connected to the HDMI input on the VX-6000d (see Figure 3-10).</li> </ul>
The projector and DHD Controller are both on and menus appear on-screen, but there is no picture.	<ul style="list-style-type: none"> <li>Incorrect source selection.</li> <li>Source component is not turned on.</li> <li>Source component is connected incorrectly or not at all.</li> </ul>	<ul style="list-style-type: none"> <li>Select the correct source.</li> <li>Turn on the source.</li> <li>Check video connections to source component.</li> </ul>
A projected image from a DVD is split or otherwise scrambled.	<ul style="list-style-type: none"> <li>DVD player is connected to the Component input and set to progressive scan mode.</li> </ul>	<ul style="list-style-type: none"> <li>Turn off progressive scan on the DVD player. Or, connect the DVD player to the HD1 or HD2 input.</li> </ul>
Image is too bright and/or lacks definition in the bright areas of the image.	<ul style="list-style-type: none"> <li>Contrast is set too high.</li> </ul>	<ul style="list-style-type: none"> <li>Lower the contrast setting.</li> </ul>
Image appears "washed out" and/or dark areas appear too bright.	<ul style="list-style-type: none"> <li>Brightness is set too high.</li> </ul>	<ul style="list-style-type: none"> <li>Lower the brightness setting.</li> </ul>
Colors in the image are swapped (for example, reds appear blue or vice versa) on one or more sources.	<ul style="list-style-type: none"> <li>The Red/Pr, Green/Y or Blue/Pb outputs from the source are connected to the wrong inputs on the DHD Controller.</li> </ul>	<ul style="list-style-type: none"> <li>Ensure that the source outputs are connected to the correct DHD Controller input.</li> </ul>

**Table 5-1. Troubleshooting Chart (continued)**

Symptom	Possible Cause(s)	Solution
Image geometry is incorrect.	<ul style="list-style-type: none"> <li>• Incorrect aspect ratio selection.</li> <li>• Image height may need adjusting (VX-6000d/CineWide only).</li> </ul>	<ul style="list-style-type: none"> <li>• Select the aspect ratio that best matches the source image and screen size (refer to Table 4-1).</li> <li>• Adjust displayed image height (refer to <b>Output Shift</b> on page 67).</li> </ul>
The projected image is trapezoidal in shape.	<ul style="list-style-type: none"> <li>• The projector is not perpendicular to the screen.</li> </ul>	<ul style="list-style-type: none"> <li>• Adjust the projection angle.</li> </ul>
The projector will not turn back on after it was powered down, or the image disappears during operation.	<ul style="list-style-type: none"> <li>• The projector will not turn on for two minutes after power-down, to protect the lamp.</li> <li>• The lamp has failed or reached its usage limit of 2000 hours.</li> </ul>	<ul style="list-style-type: none"> <li>• Wait two minutes until the LED at the front of the DHD Controller turns red.</li> <li>• Replace the lamp.</li> </ul>

**Notes:**

# 6. External Control

In addition to using the DHD Controller front-panel keypad or remote control unit, there are two methods of controlling the VX-6000d and DHD Controller externally:

- Using a serial (RS-232) link to send ASCII commands and receive responses to those commands.
- Using discrete infrared (IR) codes to program a third-party remote control unit.

The following sections describe both of these methods.

The DHD Controller uses a simple text-based control protocol to take requests from control devices and to provide responses to such devices. This section describes how to send control messages over a serial link between the DHD Controller and an automation/control system or a PC running terminal emulation software.

To interface the DHD Controller with a home theater automation/control system or a PC running terminal emulation software, connect it to your control system or PC as shown in Figure 3-16.

Configure the RS-232 controller or PC serial port as follows: no parity, 8 data bits, 1 stop bit and no flow control. Set the baud rate to 19200, to match that of the DHD Controller RS-232 port.

Serial commands to the DHD Controller take the following form:

- Commands are not case-sensitive.
- For a single command that takes no parameters, type the command followed by a carriage return; for example, to set the aspect ratio to Letterbox, type `LETTERBOX <Enter>`.
- For a single command that takes a parameter, type the command, a space or a comma and the desired value followed by a carriage return; for example, to set the brightness to -10, type `BRIGHTNESS -10 <Enter>` or `BRIGHTNESS,-10 <Enter>`.
- You can also send a string of multiple commands on a single line, separated by commas. For example, `COMPOSITE,BRIGHTNESS 50,16:9<Enter>` switches to the Composite video input, sets the brightness to 50 and sets the aspect ratio to 16:9. Command strings can be up to 255 characters long.



## Note

Avoid combining the `ON` or `POWER 1` commands with other commands on a single line. After sending `ON` or `POWER 1`, allow at least five (5) seconds for the DHD Controller to power up. If you have enabled the ISF splash screen (refer to **Splash Configure** on page 67), allow 15 seconds for the DHD Controller to power up.

Once it does, it will accept and properly execute multiple serial commands.

## 6.1 Serial Communications

### ◀ RS-232 Connection and Port Configuration

### ◀ Serial Command Syntax

Table 6-1 lists the RS-232 command set. The “Parameter (min/max)” column shows the valid parameter ranges, or “NA” for commands that take no parameters.

When you enter a valid command, the DHD Controller executes it and acknowledges it with a plus sign on the command line (+ >). When you enter an invalid command – one that is misspelled or followed by values outside the valid range for that command – the DHD Controller ignores it and returns a minus sign (- >).

**Table 6-1. Serial Commands**

Command	Parameter (min/max)	Value Stored?	Description
<b>Power On/Off Commands</b>			
OFF	NA	NA	Turns display off
ON	NA	NA	Turns display on
POWER	0/1	NA	Turns display on and off
POWER?	NA	NA	Returns power status
<b>Input Selection Commands</b>			
COMPONENT	NA	YES	Selects the Component input
COMPOSITE	NA	YES	Selects the Composite video input
HDMI1	NA	YES	Selects the HDMI 1 input
HDMI2	NA	YES	Selects the HDMI 2 input
HD1	NA	YES	Selects the RGB HD 1 input
HD2	NA	YES	Selects the RGB HD 2 input
INPUT?	NA	NA	Returns active input
SCART	NA	YES	Selects the SCART input
SVIDEO1	NA	YES	Selects the S-Video 1 input
SVIDEO2	NA	YES	Selects the S-Video 2 input



**Table 6-1. Serial Commands (continued)**

Command	Parameter (min/max)	Value Stored?	Description
<b>Aspect Ratio Commands</b>			
16:9	NA	YES	Selects the 16:9 aspect ratio
4:3	NA	YES	Selects the 4:3 aspect ratio
ASPECT?	NA	NA	Returns current aspect ratio
CINEMA	NA	YES	Selects the Cinema aspect ratio
LETTERBOX	NA	YES	Selects the Letterbox aspect ratio
NATIVE	NA	YES	Selects the Native aspect ratio
VIRTUALWIDE	NA	YES	Selects the VirtualWide aspect ratio
VIRTUALCINEMA	NA	YES	Selects the Virtual Cinema aspect ratio
<b>Picture Adjust Commands</b>			
BRIGHTNESS	-50/50	YES	Sets a value for brightness
BRIGHTNESS?	NA	NA	Returns brightness setting value
CHROMADELAY	-7/7	YES	Sets a value for input color chroma delay
CHROMADELAY?	NA	NA	Returns input color chroma delay setting
COLOR	-50/50	YES	Sets a value for color
COLOR?	NA	NA	Returns color setting value
CONTRAST	-50/50	YES	Sets a value for contrast
CONTRAST?	NA	NA	Returns contrast setting value
FILMMODE	0/1	YES	Sets Film Mode off (0) or on (1)
FILMMODE?	NA	NA	Returns Film Mode setting (0 = off; 1 = on)
FILTER	0/10	YES	Sets a value for input color noise filter
FILTER?	NA	NA	Returns input color noise filter setting
PHASE	0/31	YES	Adjusts phase
PHASE?	NA	NA	Returns phase setting value
SHARPNESS	-50/50	YES	Sets a value for sharpness
SHARPNESS?	NA	NA	Returns sharpness setting value
TINT	-50/50	YES	Sets a value for tint
TINT?	NA	NA	Returns tint setting value

**Table 6-1. Serial Commands (continued)**

Command	Parameter (min/max)	Value Stored?	Description
<b>Image Preset Commands</b>			
CUSTOM1	NA	YES	Loads "Custom" image preset
CUSTOM2	NA	YES	Loads "THX" ("Custom 2") image preset
DAY	NA	YES	Loads "ISF Day" image preset
NIGHT	NA	YES	Loads "ISF Night" image preset
PRESET?	NA	NA	Returns currently-selected preset (ISF Day, ISF Night, Custom or THX)
<b>Input Position Commands</b>			
IHEIGHT	0/20	YES	Sets the value for input height
IHEIGHT?	NA	NA	Returns input height value
IHPOS	-50/50	YES	Sets a value for horizontal input position
IHPOS?	NA	NA	Returns input horizontal position value
IVPOS	-50/50	YES	Sets a value for vertical input position
IVPOS?	NA	NA	Returns input vertical position value
IWIDTH	0/50	YES	Sets the value for input width
IWIDTH?	NA	NA	Returns input horizontal width value
OVERSCAN	0/20	YES	Sets the overscan percentage
OVERSCAN?	NA	NA	Returns overscan percentage
OVERSCANMODE	0/1	YES	Sets the overscan mode (0=zoom; 1=crop)
OVERSCANMODE?	NA	NA	Returns the overscan mode (0=zoom; 1=crop)
<b>Output Shift Commands</b>			
OHEIGHT	-50/50	YES	Sets the value for output height
OHEIGHT?	NA	NA	Returns output height value
OHPOS	-50/50	YES	Sets the value for output horizontal position
OHPOS?	NA	NA	Returns output horizontal position value
OVPOS	-50/50	YES	Sets the value for output vertical position
OVPOS?	NA	NA	Returns output vertical position value
OWIDTH	-50/50	YES	Sets the value for output width
OWIDTH?	NA	NA	Returns output horizontal width value

**Table 6-1. Serial Commands (continued)**

Command	Parameter (min/max)	Value Stored?	Description
<b>Miscellaneous Commands</b>			
DISPLAY?	NA	NA	Returns display device input source value, as follows: 1 = Auto 32 = VX-6000d
INRES?	NA	NA	Returns input resolution
MODEL?	NA	NA	Returns product model name
OUTRES?	NA	NA	Returns output resolution
SERNUM?	NA	NA	Returns DHD Controller serial number
SWVER?	NA	NA	Returns software version number
SYSSTATE?	0/4	NA	Returns current system state 0 = Off 1 = Initializing 2 = On 3 = Powering Down 4 = Error
TRIGGER	1/3	YES	Assigns trigger to currently-selected aspect ratio
The following serial commands are meant to emulate buttons on the remote control or DHD Controller front panel. Each button has its own serial command, so effectively it is as if you were using the IR remote only you'll be doing so via serial commands. These commands provide active OSD responses just like the IR remote.			
DOWN	NA	NA	Down-Arrow (▼) key
ENTER	NA	NA	<b>ENTER</b> key
EXIT	NA	NA	<b>EXIT (RETURN)</b> key
LEFT	NA	NA	Left-Arrow (◀) key
MENU	NA	NA	<b>MENU</b>
RIGHT	NA	NA	Right-Arrow (▶) key
UP	NA	NA	Up-Arrow (▲) key

## 6.2 Using Discrete IR Codes

The DHD Controller accepts commands in the form of IR signals that conform to the Phillips RC5 protocol. Each DHD Controller remote control button has an RC5 control code associated with it.

You can use these codes to program a third-party, “universal” remote control unit to work with the DHD Controller. These third-party products usually come with a computer software application for this purpose. For more information, consult the documentation provided with the remote control unit.

### IR Command Protocol ➤

The IR control codes have the following characteristics:

- Each code consists of 14 bits:
  - Two (2) **start bits** (always 1);
  - A **toggle bit**. This bit is inverted every time a key is released and pressed again. This allows the DHD Controller to distinguish between a button that remains down and one that is pressed repeatedly.
  - Five (5) **address bits**. The default address is **17** (binary 10001). To change it, select Remote Control from the Service menu and follow the steps given on page 69.
  - Six (6) **data bits**.
- The carrier frequency is 36 kHz, with the modulated pulses having a 25% duty cycle.
- Commands are sent at a maximum rate of 9 Hz.

For example, here is the RC5 control code for the **ON** button on the DHD Controller remote control unit (assuming the default address is used):

With Toggle Bit = 0														
Hex	3		4				4				1			
Binary	1	1	0	1	0	0	0	1	0	0	0	0	0	1
With Toggle Bit = 1														
Hex	3		C				4				1			
Binary	1	1	1	1	0	0	0	1	0	0	0	0	0	1
Function	Start Bits	Toggle Bit	Address				Command							

Figure 6-1 shows the pulse train for this command (with the toggle bit set to zero).

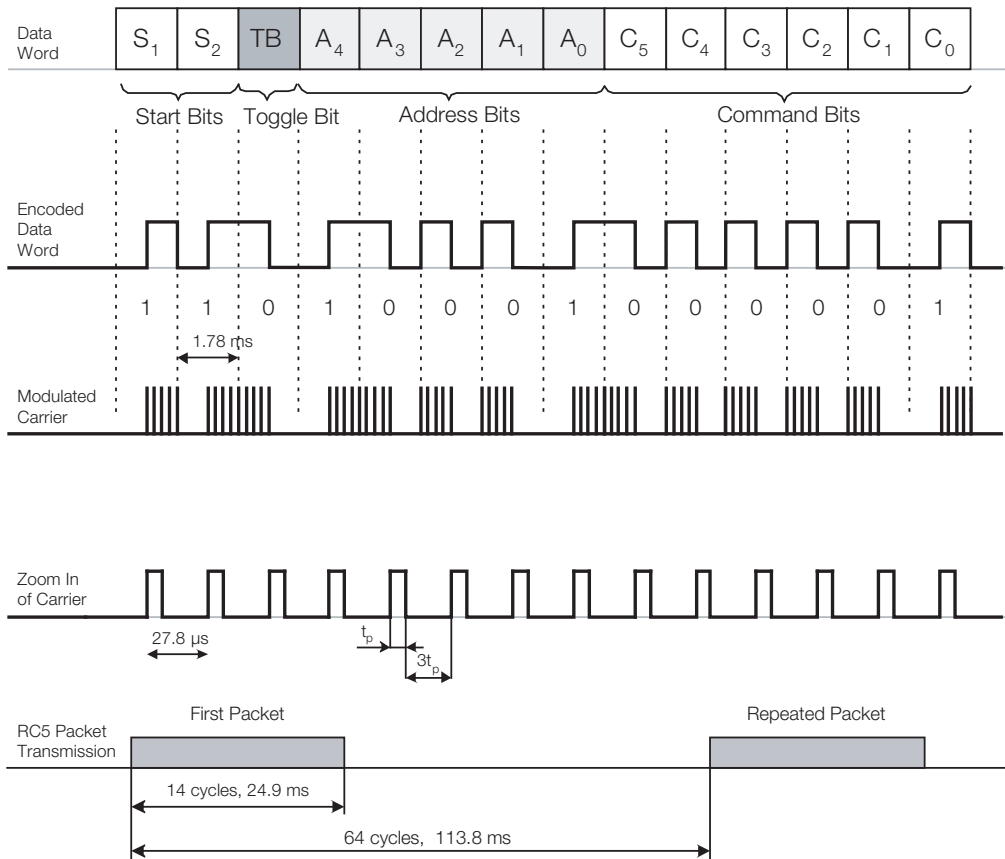

**Figure 6-1. RC5 Message Format**

Table 6-2 lists the RC5 control codes for the DHD Controller.

◀ **IR Command List**

**Table 6-2. RC5 Control Codes for the DHD Controller**

Remote Control Button Name	RC5 Data from Remote Control (Note)	RC5 Data with Toggle Bit = 1 (Note)	Description
(none)	0x346E	0x3C6E	Native aspect ratio
(none)	0x3457	0x3C57	SCART video input
16:9	0x3449	0x3C49	16:9 aspect ratio
4:3	0x344A	0x3C4A	4:3 aspect ratio
CINEMA	0x346C	0x3C6C	Cinema aspect ratio
COMP	0x344E	0x3C4E	Component video input

**Note:** These codes assume that the default address of 17 is used. If you change it to something other than 17, you will need to modify these codes accordingly.

**Table 6-2. RC5 Control Codes for the DHD Controller (continued)**

Remote Control Button Name	RC5 Data from Remote Control (Note)	RC5 Data with Toggle Bit = 1 (Note)	Description
CUST 1	0x3472	0x3C72	Custom memory preset
CUST 2	0x3473	0x3C73	THX memory preset
DOWN	0x3446	0x3C46	Down-Arrow (▼)
ENTER	0x3444	0x3C44	<b>ENTER</b>
EXIT	0x3474	0x3C74	<b>EXIT (RETURN)</b>
HD 1	0x3451	0x3C51	HD1 video input
HD 2	0x3452	0x3C52	HD2 video input
HDMI 1	0x3453	0x3C53	HDMI1 video input
HDMI 2	0x3454	0x3C54	HDMI2 video input
ISF DAY	0x3471	0x3C71	ISF Day memory preset
ISF NIGHT	0x3470	0x3C70	ISF Night memory preset
LEFT	0x3447	0x3C47	Left-Arrow (◀)
LET BOX	0x344B	0x3C4B	Letterbox aspect ratio
MENU	0x3443	0x3C43	<b>MENU</b>
OFF	0x3442	0x3C42	Power off
ON	0x3441	0x3C41	Power on
RIGHT	0x3448	0x3C48	Right-Arrow (▶)
SVC	0x346D	0x3C6D	Virtual Cinema aspect ratio
S-VID 1	0x344F	0x3C4F	S-Video 1 video input
S-VID 2	0x3450	0x3C50	S-Video 2 video input
UP	0x3445	0x3C45	Up-Arrow (▲)
VIDEO	0x344D	0x3C4D	Composite video input
V-WIDE	0x344C	0x3C4C	VirtualWide aspect ratio

**Note:** These codes assume that the default address of 17 is used. If you change it to something other than 17, you will need to modify these codes accordingly.

# 7. Specifications

Table 7-1 lists the VX-6000d specifications.

**Table 7-1. VX-6000d Specifications**

<b>Projector Type:</b>	Digital Light Processing (DLP), single-chip, 16:9 SuperOnyx™ DMD
<b>Native Resolution:</b>	1920 x 1080 (16:9)
<b>Aspect Ratios:</b>	Refer to Table 7-2
<b>Video Standards:</b>	Refer to Table 7-2
<b>DTV Compatibility:</b>	480p, 720p, 1080i, 1080p
<b>Scan Frequency:</b>	Horizontal: 15 - 81 kHz Vertical: 43 - 100 Hz
<b>Picture Size (16:9 Screen):</b>	Recommended Width: 72 - 96 in. Maximum Width: 200 in.
<b>Throw Distance (Factor x Screen Width):</b>	Refer to Table 3-3
<b>Horizontal and Vertical Offset:</b>	Refer to Table 3-4
<b>Lamp:</b>	220 Watts
<b>Estimated Lamp Life:</b>	2000 hours
<b>Inputs (from DHD Controller):</b>	(1) HDMI with HDCP, (1) RS-232

## 7.1 VX-6000d Specifications

**Table 7-1. VX-6000d Specifications (continued)**

<b>Brightness and Contrast (variable, depending on RVR calibration):</b>	<p><b>Cinema Standards Measurement System (CSMS) Specifications</b></p> <ul style="list-style-type: none"> <li>- Brightness: 17.3 to 29.8 foot-Lamberts (fL)</li> <li>- Contrast Ratio: 285:1 to 360:1</li> </ul> <p>These measurements are taken from the projector in a controlled, home theater environment. All measurements are made to ANSI/NAPM IT7.228-1997 specifications using the Photo Research PR-650 SpectraColorimeter and Minolta LS-100 Luminance Meter, Video Essentials test DVD and a 1.3 gain, 72-inch wide screen. The projector is calibrated to a color temperature of 6,500K and has a minimum of 150 hours of usage.</p> <p>The foot-Lambert (fL) is the unit of measurement used in commercial movie theaters to express image brightness at the screen surface. The Society of Motion Picture and Television Engineers (SMPTE) specifies 16 fL as the target image brightness for film-based projectors using an open gate (without film in the projector). More importantly, today SMPTE specifies 12 fL as the target image brightness in Digital Cinema theaters. The foot-Lambert measurement is dependent on screen size, screen gain and projector light output.</p> <p><b>Home Theater Calibration Specifications</b></p> <ul style="list-style-type: none"> <li>- Light Output: 468 to 801 ANSI Lumens</li> <li>- Contrast Ratio: 285:1 to 360:1</li> </ul> <p>These specifications are obtained by calibrating the projector as described above for CSMS measurements.</p> <p><b>Industry-Standard Specifications</b></p> <ul style="list-style-type: none"> <li>- Light Output: 1750 ANSI Lumens</li> <li>- Contrast Ratio: 4450:1 to 5000:1</li> </ul> <p>These are typical projector brightness and contrast specifications found in most companies' sales literature. Runco includes these measurements in its literature to allow for direct comparison with other manufacturers' projectors. These measurements are typically taken at 9,000K to 13,000K to get expected performance data when the projector is used in professional, commercial and industrial displays.</p>
<b>Power Requirements:</b>	100 to 240 VAC (auto-sensing), 50/60 Hz, 380 Watts (1296.9 BTUs/hour)
<b>Operating Environment:</b>	40°F to 95°F (5°C to 35°C), 0% to 90% humidity (non-condensing)
<b>Dimensions:</b>	See Figure 7-1
<b>Weight (without lens):</b>	73 lbs. (33.11 kg)
<b>Regulatory Approvals:</b>	Complies with FCC, CE C-Tick
<b>Limited Warranty:</b>	Projector: Two (2) years parts and labor from the date of delivery to the end user. Lamp: 1000 hours or six (6) months, whichever comes first.

**Specifications are subject to change without notice.**



Table 7-2 lists the DHD Controller specifications.

**Table 7-2. DHD Controller Specifications**

<b>Aspect Ratios:</b>	4:3, Letterbox, 16:9, VirtualWide, Cinema, Virtual Cinema, Native
<b>Video Standards:</b>	NTSC, PAL, SECAM
<b>Inputs:</b>	(1) Composite (2) S-Video (1) Component/RGBHV/SCART (5 x RCA) (2) Component/RGBHV (5 x BNC) (2) HDMI 1.3 with HDCP
<b>Outputs:</b>	HDMI 1.3 with HDCP
<b>Control Options:</b>	<ul style="list-style-type: none"> <li>- Discrete infrared remote</li> <li>- Serial commands via RS-232</li> <li>- Front-panel controls</li> </ul>
<b>RS-232 Communication Parameters:</b>	19200 bps, no parity, 8 data bits, 1 stop bit, no flow control
<b>Trigger Outputs:</b>	(3) +12 VDC, each rated at 250 mA and thermal fuse-protected
<b>Bandwidth:</b>	150 Mega Samples per Second (MSPS)
<b>Power Requirements:</b>	100 to 240 VAC (auto-sensing), 50/60 Hz, 160 Watts
<b>Operating Environment:</b>	41°F to 95°F (5°C to 35°C), 0% to 90% humidity (non-condensing)
<b>Dimensions:</b>	Width = 17.50 inches (444.5 mm) Depth = 11.19 inches (284.1 mm) Height = 3.75 inches (95.3 mm)
<b>Weight:</b>	13.0 lbs. (5.90 kg)
<b>Regulatory Approvals:</b>	Complies with FCC, CE C-Tick
<b>Limited Warranty:</b>	Two (2) years parts and labor from the date of delivery to the end user.
<b>Specifications are subject to change without notice.</b>	

## 7.2 DHD Controller Specifications

### 7.3 VX-6000d Dimensions

Figure 7-1 shows the VX-6000d/CineWide dimensions (all dimensions are in inches).

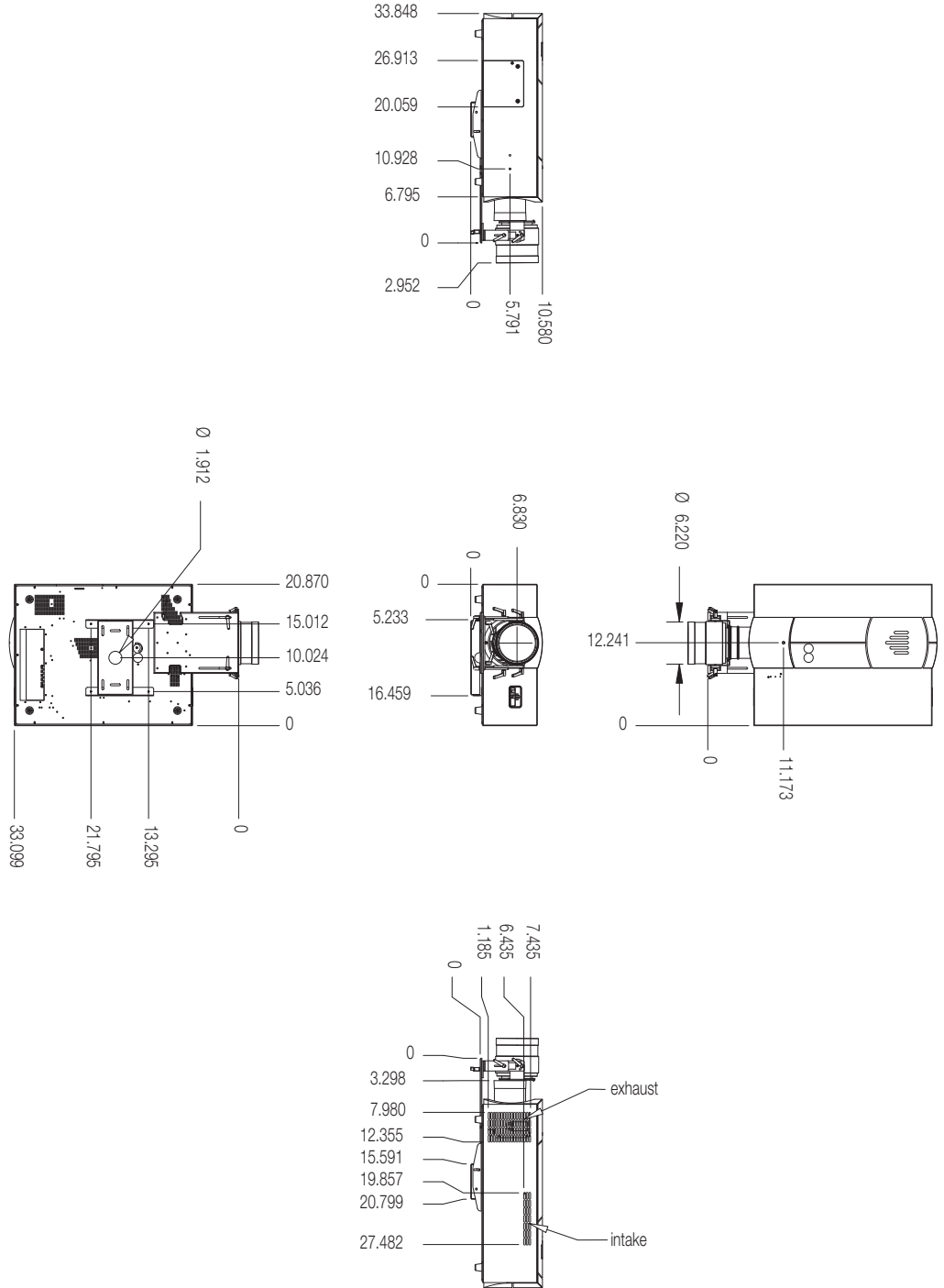

**Figure 7-1. VX-6000d/CineWide Dimensions (with Optional Ceiling Mount)**

Table 7-3 lists the signal types supported by each input on the DHD Controller.

## 7.4 Supported Timings

**Table 7-3. Supported Signal Timings by Input**

Format	Resolution	Refresh Rate (Hz)	Horizontal Frequency (kHz)	Pixel Frequency (MHz)	Supported? (√ = Yes, - = No)					
					HD1 HD2	HDMI 1 HDMI 2	Component/ RGBHV	SCART	S-Video 1 S-Video 2	Video
640x480	640x480	60.00	31.469	25.175	√	√	√	-	-	-
		66.59	35.892	29.862	√	√	√	-	-	-
		72.00	37.861	31.500	√	√	√	-	-	-
		75.00	37.500	31.500	√	√	√	-	-	-
		85.00	43.269	36.000	√	√	√	-	-	-
800x600	800x600	60.00	37.879	40.000	√	√	√	-	-	-
		72.00	48.077	50.000	√	√	√	-	-	-
		75.00	46.875	49.500	√	√	√	-	-	-
		85.00	53.674	56.250	√	√	√	-	-	-
832x624	832x624	74.54	52.849	60.036	√	√	√	-	-	-
848x480	848x480	47.95	25.270	27.089	√	√	√	-	-	-
		60.00	31.020	33.750	√	√	√	-	-	-
1024x768	1024x768	60.00	48.363	65.000	√	√	√	-	-	-
		70.00	56.476	75.000	√	√	√	-	-	-
		75.00	60.023	78.750	√	√	√	-	-	-
		85.00	68.677	94.500	√	√	√	-	-	-
1152x864	1152x864	75.00	67.500	108.000	√	√	√	-	-	-
1280x720	1280x720	47.95	37.833	64.769	√	√	√	-	-	-
1280x768	1280x768	60.00	47.396	68.250	√	√	√	-	-	-
		60.00	47.776	79.500	√	√	√	-	-	-
		75.00	60.289	102.250	√	√	√	-	-	-
		85.00	68.633	117.500	√	√	√	-	-	-
1280x960	1280x960	60.00	60.000	108.000	√	√	√	-	-	-
		85.00	85.938	148.500	√	√	√	-	-	-

**Table 7-3. Supported Signal Timings by Input (continued)**

Format	Resolution	Refresh Rate (Hz)	Horizontal Frequency (kHz)	Pixel Frequency (MHz)	Supported? (√ = Yes, – = No)					
					HD1 HD2	HDMI 1 HDMI 2	Component/ RGBHV	SCART	S-Video 1 S-Video 2	Video
1280x1024	1280x1024	60.00	63.981	108.000	√	√	√	–	–	–
		75.00	79.976	135.000	√	√	√	–	–	–
		85.00	91.146	157.500	√	√	√	–	–	–
1360x768	1360x768	60.00	47.712	85.500	√	√	√	–	–	–
1400x1050	1400x1050	60.00	64.744	101.000	√	√	√	–	–	–
		60.00	65.317	121.750	√	√	√	–	–	–
		75.00	82.278	156.000	√	√	√	–	–	–
1600x1200	1600x1200	60.00	75.000	162.000	√	√	√	–	–	–
1680x1050	1680x1050	60.00	64.674	119.000	√	√	√	–	–	–
1920x1080	1920x1080	47.95	56.821	150.007	√	√	√	–	–	–
1920x1200	1920x1200	60.00	74.038	154.000	√	√	√	–	–	–
SCART RGS	–	50.00	–	–	–	–	–	√	–	–
480/60i	720x487	59.94	15.734	13.500	√	√	√	–	–	–
480/60p	720x483	59.94	31.469	27.000	√	√	√	–	–	–
576/50i	720x576	50.00	15.625	14.750	√	√	√	–	–	–
576/50p	720x576	50.00	31.250	29.000	√	√	√	–	–	–
720/24p	1280x720	23.98/24.00	17.982/18.000	59.341/59.400	√	√	√	–	–	–
720/25p	1280x720	25.00	18.750	74.250	√	√	√	–	–	–
720/30p	1280x720	29.97/30.00	22.478/22.500	74.175/74.250	√	√	√	–	–	–
720/50p	1280x720	50.00	37.500	75.250	√	√	√	–	–	–
720/60p	1280x720	60.00	45.000	74.250	√	√	√	–	–	–
1080/50i	1920x1080	50.00	28.125/31.250	74.250/72.000	√	√	√	–	–	–
1080/60i	1920x1080	59.94/60.00	33.716/33.750	74.175/74.250	√	√	√	–	–	–
1080/24p	1920x1080	23.98/24.00	26.978/27.000	74.175/74.250	√	√	√	–	–	–
1080/50p	1920x1080	50.00	56.250	148.500	√	√	√	–	–	–
1080/60p	1920x1080	59.94/60.00	67.433/67.500	148.350/148.500	√	√	√	–	–	–
NTSC 3.58	–	59.94/60.00	15.734/15.750	3.580	–	–	–	–	√	√
NTSC 4.43	–	59.94/60.00	15.734/15.750	4.430	–	–	–	–	√	√
PAL-B/G/H/I	–	50.00	15.625	4.430	–	–	–	–	√	√

**Table 7-3. Supported Signal Timings by Input (continued)**

Format	Resolution	Refresh Rate (Hz)	Horizontal Frequency (kHz)	Pixel Frequency (MHz)	Supported? (√ = Yes, - = No)					
					HD1 HD2	HDMI 1 HDMI 2	Component/ RGBHV	SCART	S-Video 1 S-Video 2	Video
PAL-M	-	59.94/60.00	15.734/15.750	3.580	-	-	-	-	√	√
PAL-N	-	50.00	15.625	3.580	-	-	-	-	√	√
SECAM	-	50.00	15.625	13.500	-	-	-	√	√	√

**Notes:**



020-0769-02 Rev. B  
May 2009

---

Runco International • (800) 23RUNCO • Fax (503) 748-8161 • [www.runco.com](http://www.runco.com)



## Free Manuals Download Website

<http://myh66.com>

<http://usermanuals.us>

<http://www.somanuals.com>

<http://www.4manuals.cc>

<http://www.manual-lib.com>

<http://www.404manual.com>

<http://www.luxmanual.com>

<http://aubethermostatmanual.com>

Golf course search by state

<http://golfingnear.com>

Email search by domain

<http://emailbydomain.com>

Auto manuals search

<http://auto.somanuals.com>

TV manuals search

<http://tv.somanuals.com>