



OPERATOR'S MANUAL

30cc String Trimmers and Brushcutters

RY30000 Series

CS30
(RY30020, RY30023)

SS30
(RY30040, RY30043)

BC30
(RY30060, RY30063)

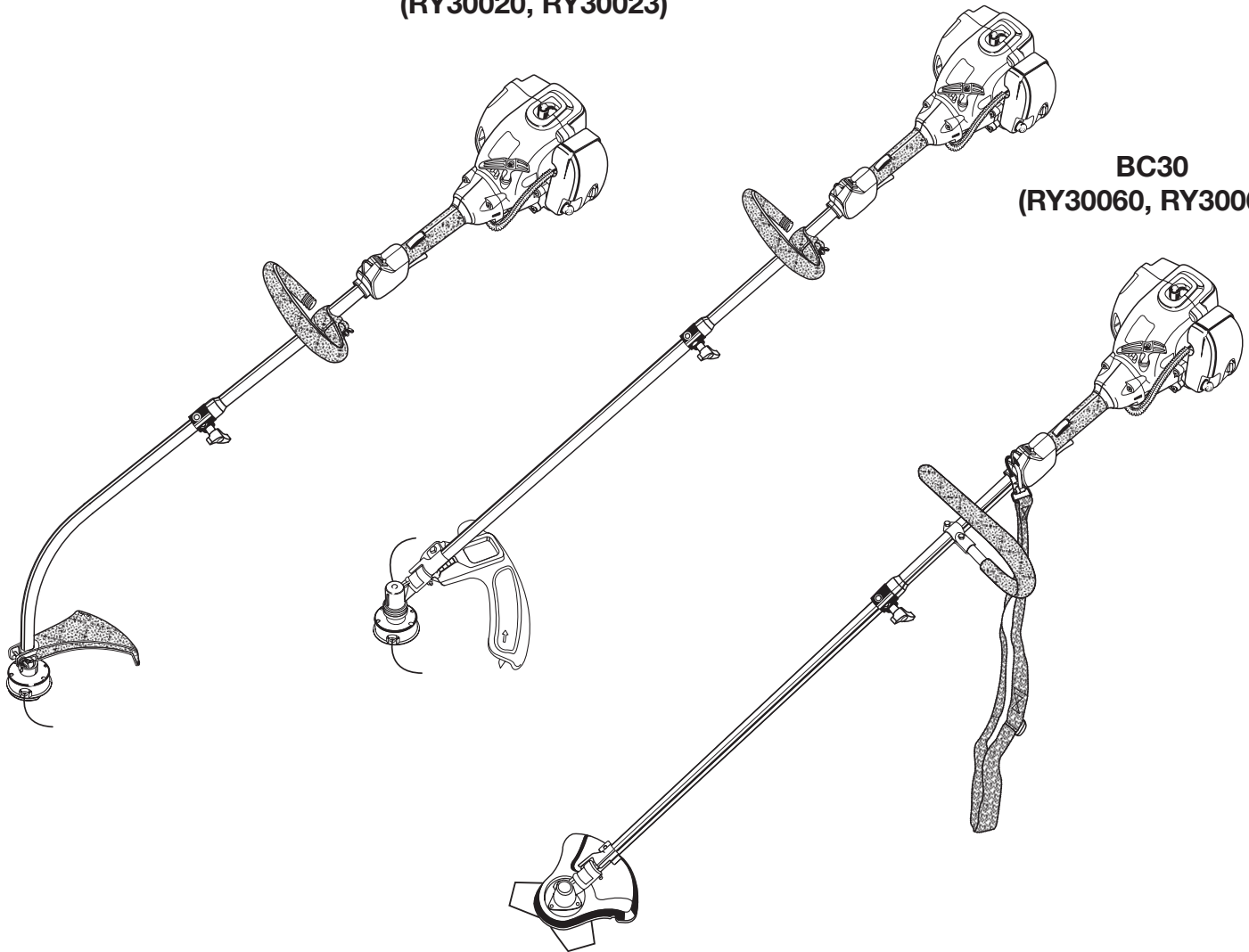

Your new trimmer has been engineered and manufactured to Ryobi's high standard for dependability, ease of operation, and operator safety. Properly cared for, it will give you years of rugged, trouble-free performance.



WARNING: To reduce the risk of injury, the user must read and understand the operator's manual before using this product.

Thank you for buying a Ryobi trimmer.

SAVE THIS MANUAL FOR FUTURE REFERENCE

TABLE OF CONTENTS

■ Introduction	2
■ General Safety Rules	3
■ Specific Safety Rules	4
■ Symbols	5 - 6
■ Specifications	7
■ Unpacking	7
■ Features	8 - 9
■ Assembly.....	10 - 14
■ Operation	15 - 18
■ Maintenance	19 - 22
■ Troubleshooting.....	23 - 24
■ Warranty.....	25 - 26
■ Service Parts.....	28

INTRODUCTION

This product has many features for making its use more pleasant and enjoyable. Safety, performance, and dependability have been given top priority in the design of this product making it easy to maintain and operate.



CALL US FIRST

For any questions about operating or maintaining your trimmer, or brushcutter call the Ryobi® Help Line!

Your trimmer has been fully tested prior to shipment to ensure your complete satisfaction.

Troubleshooting tips are also available in this operator's manual.

GENERAL SAFETY RULES

WARNING:

Read and understand all instructions. Failure to follow all instructions listed below may result in electric shock, fire and/or serious personal injury.

READ ALL INSTRUCTIONS

- For safe operation, read and understand all instructions before using this product. Follow all safety instructions. Failure to follow all safety instructions listed below, can result in serious personal injury.
 - Do not allow children or untrained individuals to use this unit.
 - Never start or run the engine in a closed or poorly ventilated area; breathing exhaust fumes can kill.
 - Clear the work area before each use. Remove all objects such as rocks, broken glass, nails, wire, or string which can be thrown or become entangled in the cutting line or blade.
 - Wear safety glasses or goggles that are marked to comply with ANSI Z87.1 standard when operating this product.
 - Wear heavy, long pants, boots, and gloves. Do not wear loose fitting clothing, short pants, or go barefoot. Do not wear jewelry of any kind.
 - Product users on United States Forest Service land, and in some states, must comply with fire prevention regulations. This product is equipped with a spark arrestor; however, other user requirements may apply. Check with your federal, state, or local authorities.
 - Never operate this unit on the operator's left side.
 - Secure long hair above shoulder level to prevent entanglement in moving parts.
 - Keep all bystanders, children, and pets at least 15 m (50 ft.) away.
 - Do not operate this unit when you are tired, ill, or under the influence of alcohol, drugs, or medication.
 - Do not operate in poor lighting.
 - Keep firm footing and balance. Do not overreach. Overreaching can result in loss of balance or exposure to hot surfaces.
 - Keep all parts of your body away from any moving part.
 - To avoid hot surfaces, never operate the unit with the bottom of the engine above waist level.
 - Do not touch area around the muffler or cylinder of the unit, these parts get hot from operation.
 - Always stop the engine and remove the spark plug wire before making any adjustments or repairs except for carburetor adjustments.
 - Inspect the unit before each use for loose fasteners, fuel leaks, etc. Replace any damaged parts before use.
 - The string head or blade will rotate during carburetor adjustments.
 - It has been reported that vibrations from hand-held tools may contribute to a condition called Raynaud's Syndrome in certain individuals. Symptoms may include tingling, numbness and blanching of the fingers, usually apparent upon exposure to cold. Hereditary factors, exposure to cold and dampness, diet, smoking and work practices are all thought to contribute to the development of these symptoms. It is presently unknown what, if any, vibrations or extent of exposure may contribute to the condition. There are measures that can be taken by the operator to possibly reduce the effects of vibration:
 - a) Keep your body warm in cold weather. When operating the unit wear gloves to keep the hands and wrists warm. It is reported that cold weather is a major factor contributing to Raynaud's Syndrome.
 - b) After each period of operation, exercise to increase blood circulation.
 - c) Take frequent work breaks. Limit the amount of exposure per day.
 - d) Keep the tool well maintained, fasteners tightened and worn parts replaced.
- If you experience any of the symptoms of this condition, immediately discontinue use and see your physician about these symptoms.
- Mix and store fuel in a container approved for gasoline.
 - Mix fuel outdoors where there are no sparks or flames. Wipe up any fuel spillage. Move 9 m (30 ft.) away from refueling site before starting engine.
 - Stop the engine and allow to cool before refueling or storing the unit.
 - Allow the engine to cool; empty the fuel tank and secure the unit from moving before transporting in a vehicle.

SPECIFIC SAFETY RULES

SPECIFIC SAFETY RULES FOR TRIMMER USE









- Replace string head if cracked, chipped, or damaged in any way. Be sure the string head or blade is properly installed and securely fastened. Failure to do so can cause serious injury.
- Make sure all guards, straps, deflectors and handles are properly and securely attached.
- Use only the manufacturer's replacement string in the cutting head. Do not use any other cutting attachment. To install any other brand of cutting head to this string trimmer can result in serious personal injury.
- Never operate unit without the grass deflector in place and in good condition.
- Maintain a firm grip on both handles while trimming. Keep string head below waist level. Never cut with the string head located over 76 cm (30 in.) or more above the ground.

SPECIFIC SAFETY RULES FOR BRUSHCUTTER AND BLADE USE

- After engine stops, keep rotating blade in thicker weeds or pulpy stalks until it stops.
- Do not operate the brushcutter unless the brushcutter guard is firmly secured in place and in good condition.
- Use heavy gloves when operating the brushcutter and when installing or removing blades.
- Always stop the engine and remove the spark plug wire before attempting to remove any obstruction caught or jammed in the blade or before removing and installing the blade.
- Do not attempt to touch or stop the blade when it is rotating.
- A coasting blade can cause injury while it continues to spin after the engine is stopped or throttle trigger released. Maintain proper control until the blade has completely stopped rotating.
- Replace any blade that has been damaged. Always make sure blade is installed correctly and securely fastened before each use. Failure to do so can cause serious injury.
- Use only the manufacturer's replacement Tri-Arc® blade intended for use on this brushcutter. Do not use any other blade. To install any other brand blade or cutting head to this brushcutter can result in serious personal injury.
- The Tri-Arc® blade is suited for cutting thicker weeds or pulpy stalks only. Do not use for any other purpose. Never use the Tri-Arc® blade to cut woody brush.
- Exercise extreme caution when using the blade with this unit. Blade thrust is the reaction that may occur when the spinning blade contacts anything it cannot cut. This contact may cause the blade to stop for an instant, and suddenly "thrust" the unit away from the object that was hit. This reaction can be violent enough to cause the operator to lose control of the unit. Blade thrust can occur without warning if the blade snags, stalls, or binds. This is more likely to occur in areas where it is difficult to see the material being cut. For cutting ease and safety, approach the weeds being cut from the right to the left. In the event an unexpected object or woody stock is encountered, this could minimize the blade thrust reaction.
- Never cut any material over 13 mm (1/2 in.) diameter.
- Always wear the shoulder harness when using the brushcutter and adjust to a comfortable operating position. Maintain a firm grip on both handles while cutting with a blade. Keep the blade away from body and below waist level.
- Never use the brushcutter with the blade located 76 cm (30 in.) or more above the ground level.



SYMBOLS

Some of the following symbols may be used on this tool. Please study them and learn their meaning for safe operation of this product.

SYMBOL	NAME	EXPLANATION
	Safety Alert Symbol	Precautions that involve your safety.
	Read the Operator's Manual	To reduce the risk of injury, user must read and understand operator's manual before using this product.
	Wear Eye and Hearing Protection	Wear eye protection which is marked to comply with ANSI Z87.1 as well as hearing protection when operating this equipment.
	Keep Bystanders Away	Keep all bystanders at least 50 ft. (15 m) away.
	Ricochet	Thrown objects can ricochet and result in personal injury or property damage.
	No Blade	Do not install or use any type of blade on a product displaying this symbol.
	Blade Thrust	Beware of blade thrust. Products authorized for blade use will display this symbol to warn of blade thrust.
	Gasoline and Oil	Use unleaded gasoline intended for motor vehicle use with an octane rating of 87 ([R + M] / 2) or higher. This product is powered by a 2-cycle engine and

SYMBOLS

The following signal words and meanings are intended to explain the levels of risk associated with this product.

SYMBOL	SIGNAL	MEANING
	DANGER:	Indicates an imminently hazardous situation which, if not avoided, will result in death or serious injury.
	WARNING:	Indicates a potentially hazardous situation which, if not avoided, could result in death or serious injury.
	CAUTION:	Indicates a potentially hazardous situation which, if not avoided, may result in minor or moderate injury.
	CAUTION:	(Without Safety Alert Symbol) Indicates a situation that may result in property damage.

SERVICE

Servicing requires extreme care and knowledge and should be performed only by a qualified service technician. For service we suggest you return the product to your nearest *AUTHORIZED SERVICE DEALER* for repair. When servicing, use only identical replacement parts.

WARNING:

To avoid serious personal injury, do not attempt to operate this product until you read thoroughly and understand completely the operator's manual. Save this operator's manual and review frequently for continuing safe operation and instructing others who may use this product.

WARNING:



The operation of any product can result in foreign objects being thrown into your eyes, which can result in severe eye damage. Before beginning operation, always wear safety goggles or safety glasses with side shields and a full face shield when needed. We recommend Wide Vision Safety Mask for use over eyeglasses or standard safety glasses with side shields. Always wear eye protection which is marked to comply with ANSI Z87.1.

SAVE THESE INSTRUCTIONS

SPECIFICATIONS

Weight - (without fuel)

CS30 (RY30020, RY30023).....	10.7 lbs. (4.9 kg.)
SS30 (RY30040, RY30043).....	12.1 lbs. (5.4 kg.)
BC30 (RY30060, RY30063).....	12.9 lbs. (5.9 kg.)

String cutting width

CS30 (RY30020, RY30023).....	17 in. (432 mm)
SS30 (RY30040, RY30043).....	18 in. (457 mm)
BC30 (RY30060, RY30063).....	18 in. (457 mm)

Blade cutting width

BC30 (RY30060, RY30063).....	8 in. (203)
------------------------------	-------------

Engine displacement30cc

String diameter

CS30 (RY30020, RY30023).....	.080 in. (2.0 mm)
SS30 (RY30040, RY30043).....	.095 in. (2.4 mm)
BC30 (RY30060, RY30063).....	.095 in. (2.4 mm)

UNPACKING

INSTRUCTIONS

- Carefully remove the product from the carton.
- Inspect the product to make sure no breakage or damage occurred during shipping.
- Do not discard the packing material until you have inspected and operated the product.
- If any parts are damaged or missing, please call 1-800-860-4050 for assistance.

WARNING:

If any parts are missing, do not operate this tool until the missing parts are replaced. Failure to do so could result in possible serious personal injury.

PACKING LIST - CS30

- Trimmer Assembly
- Owner's Kit
 - Front handle
 - Curved Shaft Grass deflector
 - Hardware Bags (2)
 - Bottle of 2-Cycle Oil
 - Hanger Cap
 - Operator's manual
 - Warranty Registration Card

PACKING LIST - SS30

- Trimmer Assembly
- Owner's Kit
 - Front handle
 - Straight Shaft Grass deflector
 - Hardware Bags (2)
 - Bottle of 2-Cycle Oil
 - Hanger Cap
 - Operator's manual
 - Warranty Registration Card

PACKING LIST - BC30

- Trimmer Assembly
- Owner's Kit
 - "J" Barrier Handle
 - Straight Shaft Grass Deflector
 - Gear Head Locking Tool
 - Hardware Bag
 - Bottle of 2-Cycle Oil
 - Shoulder Harness
 - String Head Assembly
 - Hanger Cap
 - Operator's manual
 - Warranty Registration Card

FEATURES

CS30
(RY30020, RY30023)

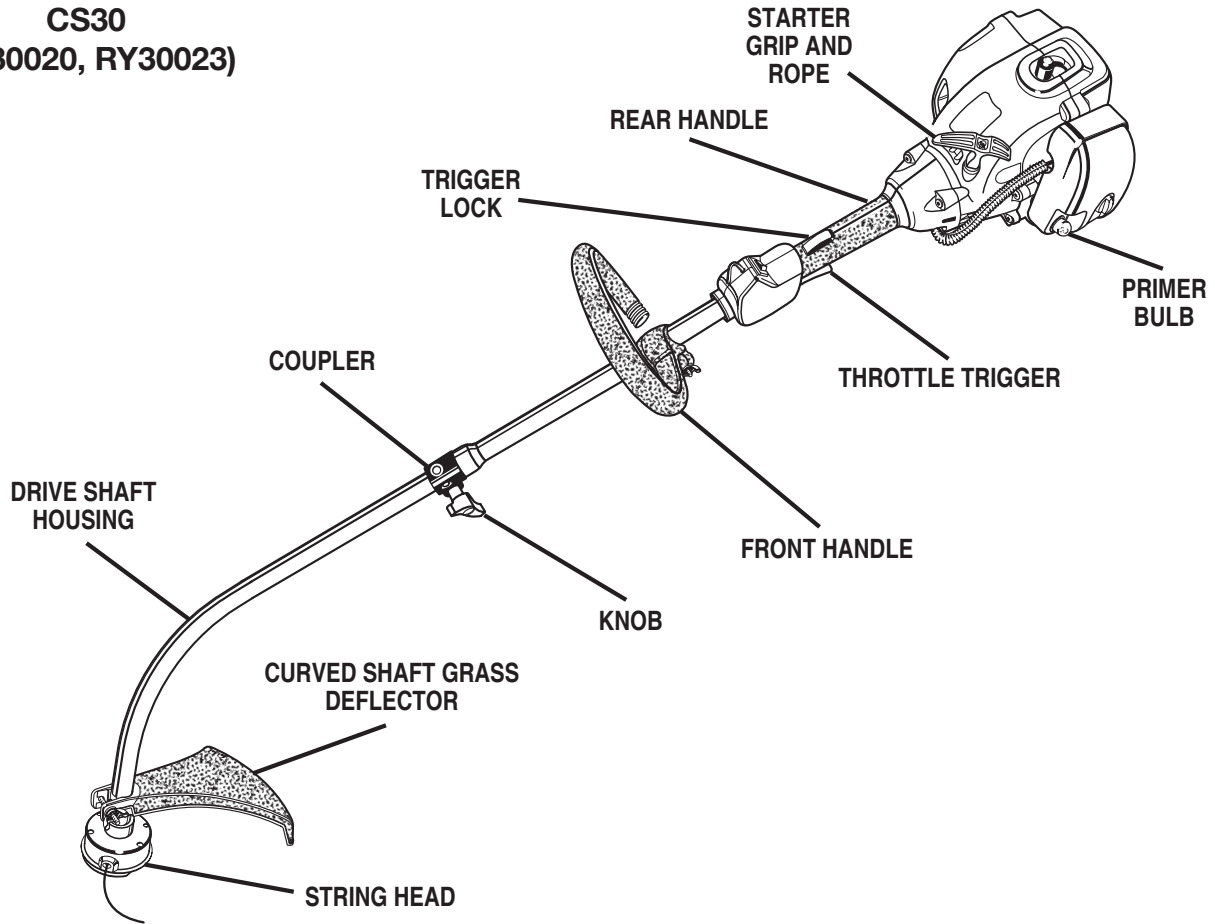

Fig. 1a

FEATURES

SS30
(RY30040, RY30043)

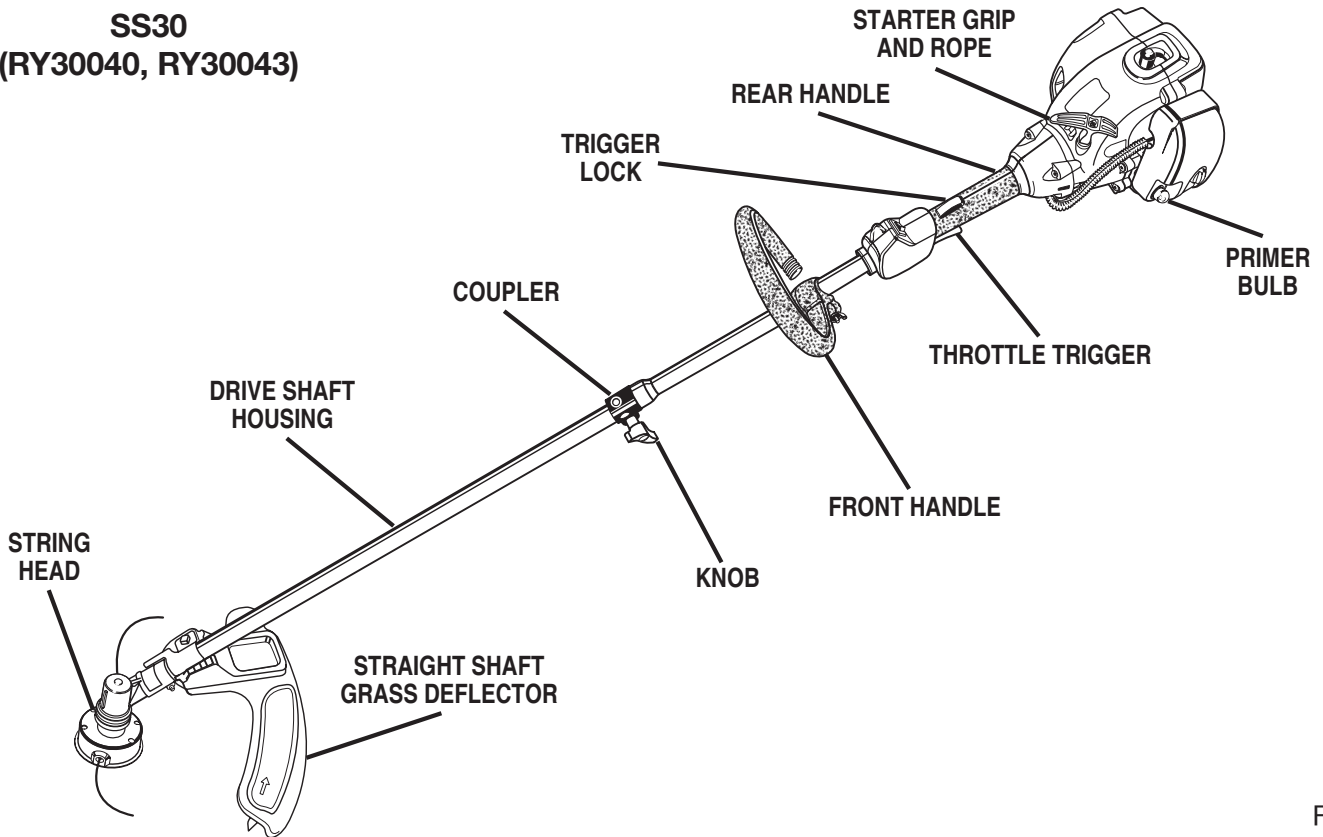

Fig. 1b

BC30
(RY30060, RY30063)

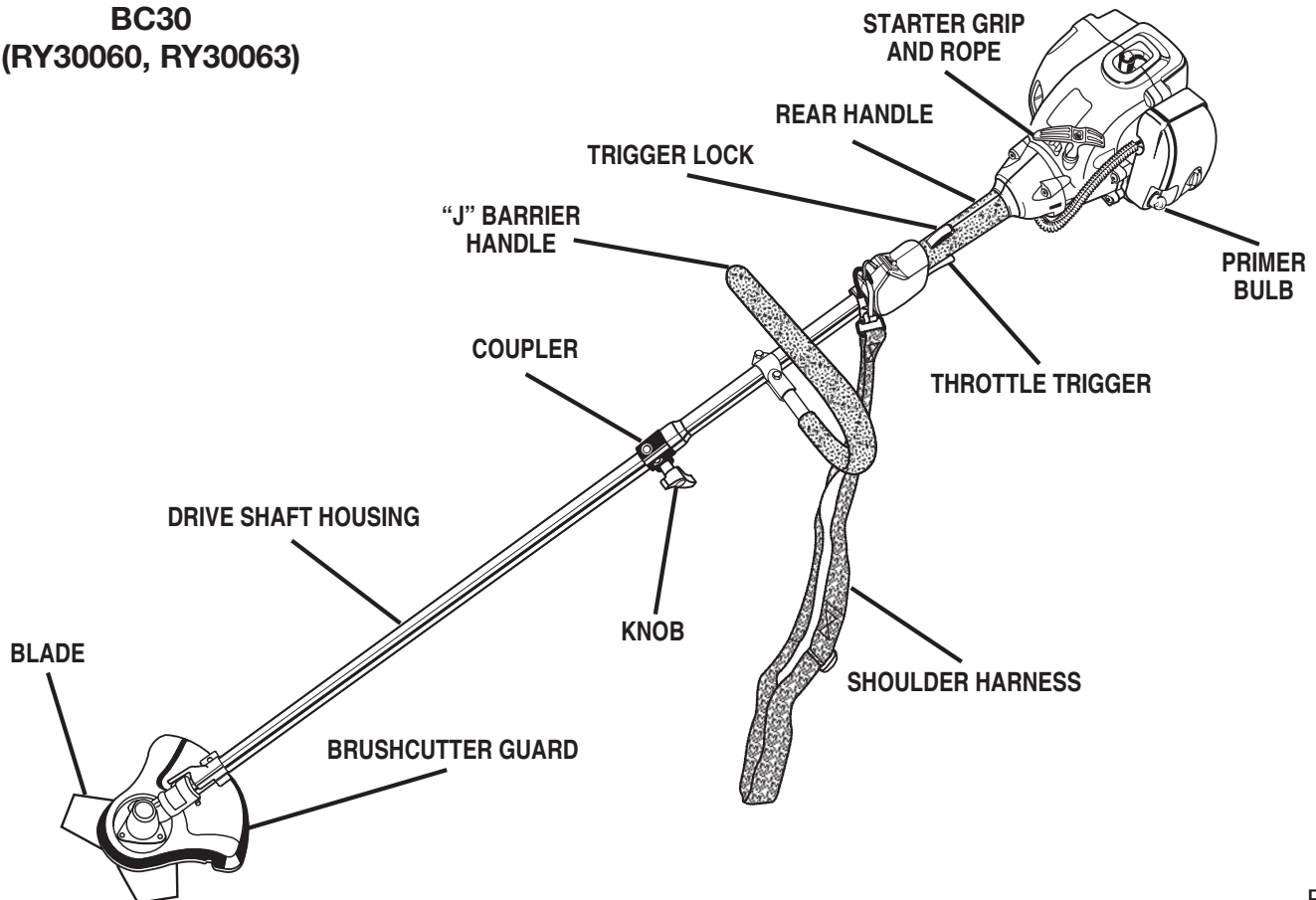

Fig. 1c

ASSEMBLY

ATTACHING THE POWER HEAD TO THE ATTACHMENT

See Figure 2.

WARNING:

Never attach or adjust any attachment while power head is running. Failure to stop the engine can cause serious personal injury.

The attachment connects to the power head by means of a coupler device.

1. Loosen the knob on the coupler of the power head shaft and remove the end cap from the attachment.
2. Push in the button located on the attachment shaft. Align the button with the guide recess on the power head coupler and slide the two shafts together. Rotate the attachment shaft until the button locks into the positioning hole.

NOTE: If the button does not release completely in the positioning hole, the shafts are not locked into place. Slightly rotate from side to side until the button is locked into place.

3. Tighten the knob securely.

WARNING:

Be certain the knob is fully tightened before operating equipment; check it periodically for tightness during use to avoid serious personal injury.

REMOVING THE ATTACHMENT FROM THE POWER HEAD

For removing or changing the attachment:

1. Loosen the knob.
2. Push in the button and twist the shafts to remove and separate ends.

ATTACHING THE STORAGE HANGER

See Figure 3.

There are two ways to hang your attachment for storage.

- To use the hanger cap, push in the button and place the hanger cap over end of the lower end attachment shaft. Slightly rotate the cap from side to side until the button locks into place.
- The secondary hole in the attachment shaft can be used for hanging purposes as well.

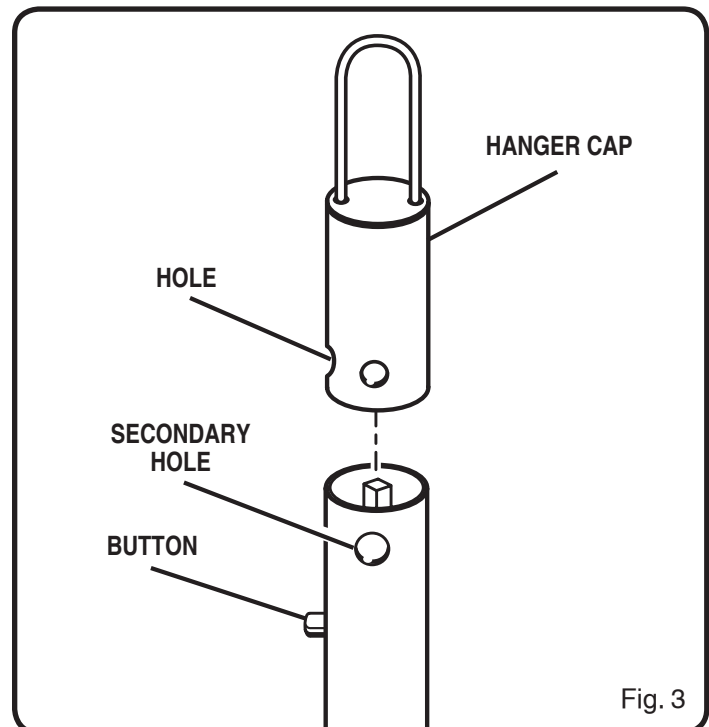
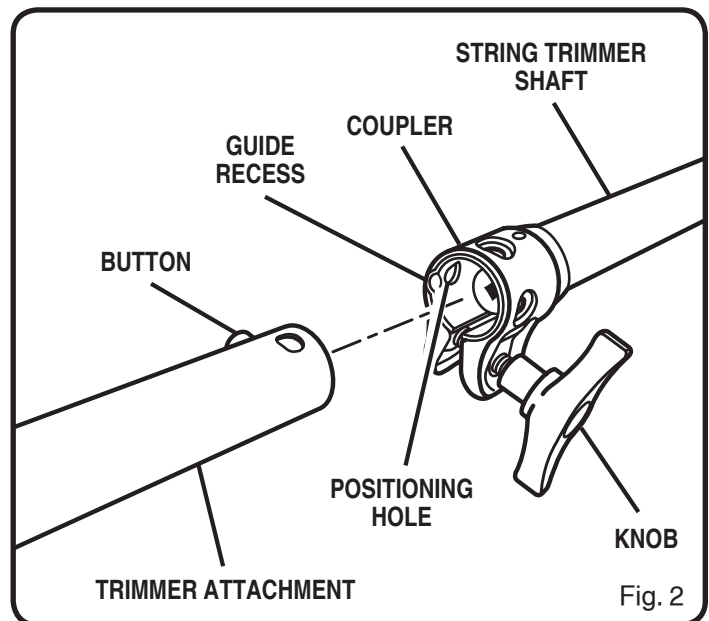

ASSEMBLY

ATTACHING THE FRONT HANDLE - CS30 AND SS30

See Figure 4.

1. Remove the front handle, bolt, flat washer, lock washer, and wing nut from the Owner's Kit.
2. Install the front handle onto the top side of the drive shaft housing and move it to a comfortable position.
3. Place the bolt through the front handle
NOTE: The hex bolt head fits inside the hex recess molded into one side of the handle.
4. Install the flat washer, lock washer, and wing nut.
5. Tighten wing nut securely.

ATTACHING THE "J" BARRIER HANDLE - BC30

See Figure 5.

A barrier handle must be used for ensuring the best control and maximizing operator safety when using a brushcutter.

1. Hold the top and bottom clamp snugly in position on the shaft housing so that handle will be located to the operator's left.
2. Insert the end of the handle between the clamps.
3. Align the bolt holes and push the long bolt (1/4-20 x 1-1/2 in.) through the handle side.
4. Place short bolt (1/4-20 x 1 in.) through opposite side of clamp. Install flat washer, lock washers and hex nuts to hold the assembly in place.
5. After assembly is complete, adjust the position of the handle for best balance and comfort.
6. Tighten first the long bolt and then the short bolt.

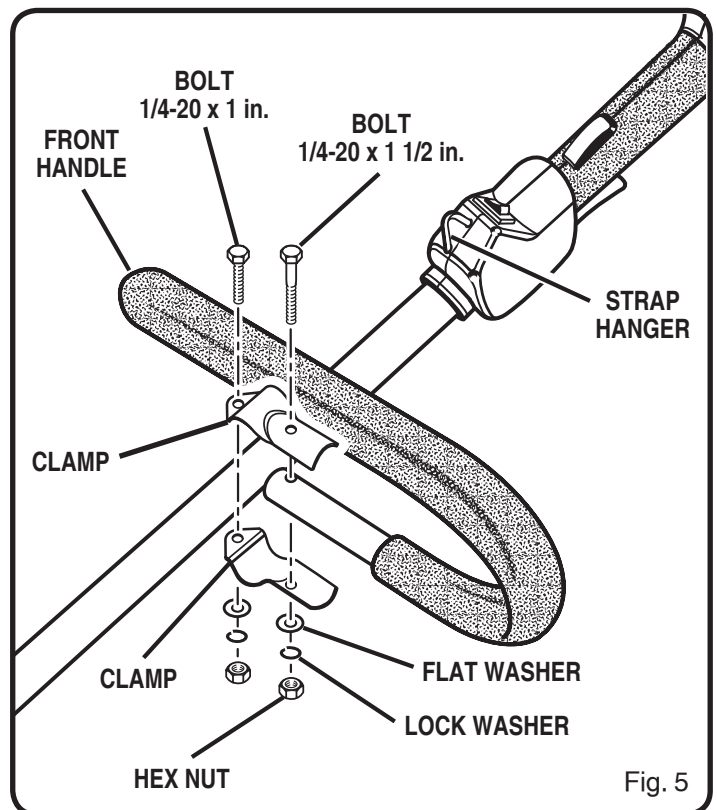
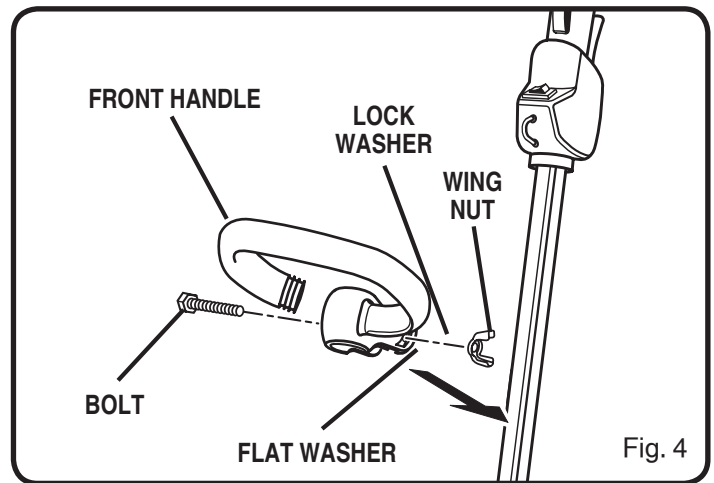

ASSEMBLY

ATTACHING THE GRASS DEFLECTOR

WARNING:

The line cutting blade on the grass deflector is sharp. Avoid contact with the blade. Failure to avoid contact can result in serious personal injury.

TO ATTACH THE CURVED SHAFT GRASS DEFLECTOR - CS30

See Figure 6.

1. Press the grass deflector onto the bottom of the curved shaft as shown.
2. Insert the hex head cap screw through the grass deflector and the bracket on the curved shaft.
3. Place the flat washer and lock washer on the hex head cap screw.
4. Place the wing nut on the hex head cap screw and tighten securely.

TO ATTACH THE STRAIGHT SHAFT GRASS DEFLECTOR - SS30

See Figure 7.

1. Remove the slotted hex head screw from the grass deflector.
2. Insert the tab on the mounting bracket in the slot on the grass deflector.
3. Align the screw hole in the mounting bracket with the screw hole in the grass deflector.
4. Insert the slotted hex head screw through the mounting bracket and into the grass deflector.
5. Tighten the screw securely.

ATTACHING THE BRUSHCUTTER GUARD - BC30

See Figure 8.

The guard is shipped installed on these brushcutter models. Instructions have been included for reference when changing from string trimmer operation back to brushcutter operation.

1. With the string head removed, place the brushcutter guard on the gear head as shown.
2. Install the three screws from bottom through the guard and into the gear head.
3. Tighten the screws securely and torque to 40-50 in.lbs. minimum (finger tight plus 1/4 turn).

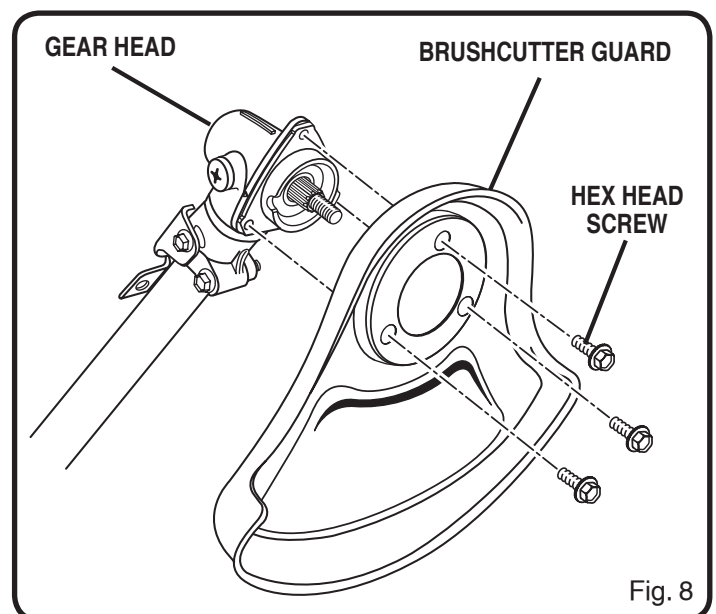
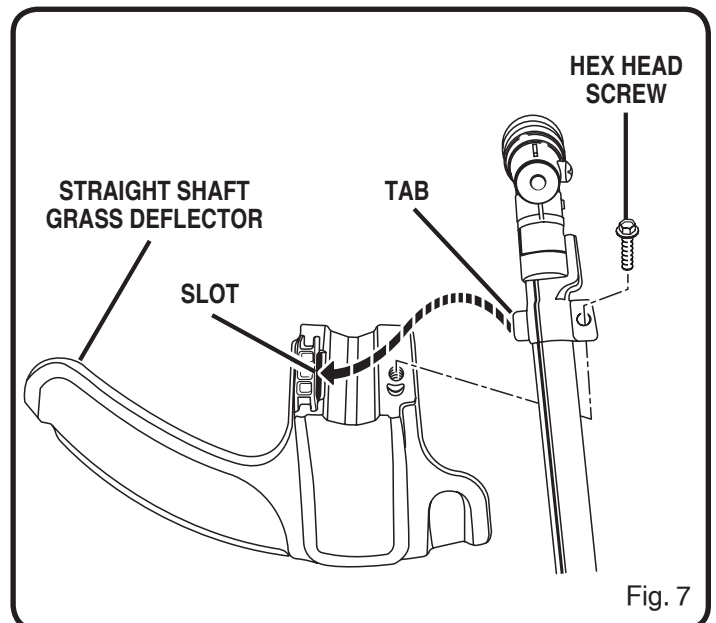
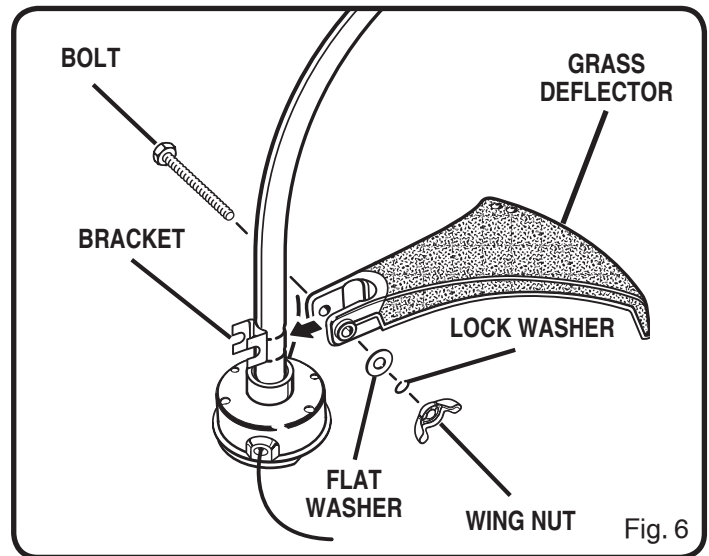

ASSEMBLY

ATTACHING THE SHOULDER HARNESS - BC30

See Figure 9.

1. Connect the latch on the shoulder harness to the strap hanger.
2. Adjust the strap to a comfortable position.

CONVERTING FROM BRUSHCUTTER TO STRING TRIMMER - BC30

To convert from the brushcutter to the string trimmer, remove the blade and brushcutter guard, attach the straight shaft grass deflector and install the string head.

REMOVING THE TRI-ARC® BLADE AND BRUSHCUTTER GUARD

See Figures 10 - 11.

1. Align the slot in the flanged washer with the slot in the gear head.
2. Place the gear head locking tool through the slot in the flanged washer and gear head.
3. Remove the blade nut by turning it clockwise.
4. Remove the cupped washer and the blade
5. Remove the flanged washer from the gear head shaft and retain it for the string head installation.
6. Remove the three screws securing the brushcutter guard to gear head.
7. Remove the brushcutter guard.

NOTE: Store the brushcutter parts together for later use.

INSTALLING THE STRAIGHT SHAFT GRASS DEFLECTOR AND STRING HEAD

See Figures 10 - 12.

1. Install the grass deflector. Refer to "To Attach the Straight Shaft Grass Deflector" earlier in this manual.
2. Place the flanged washer on the gear head shaft.

NOTE: The hollow side of the flanged washer should face the gear head.

3. Align the slot in the flanged washer with the slot in the gear head.
4. Place the gear head locking tool through the slot in the flanged washer and gear head.
5. Install the string head assembly onto the gear head shaft by turning counterclockwise.
6. Tighten the string head assembly securely.

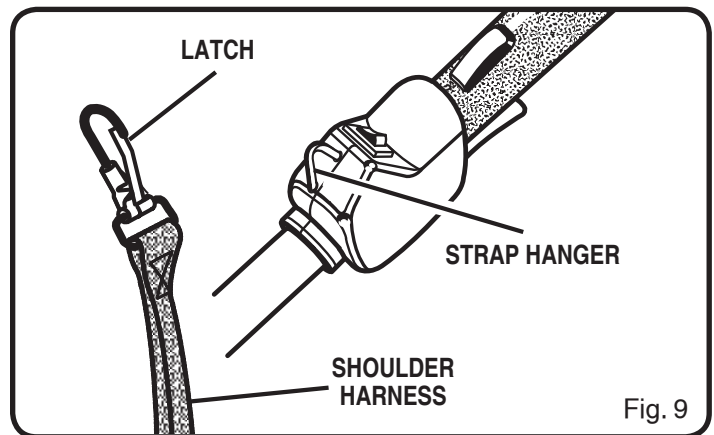

Fig. 9

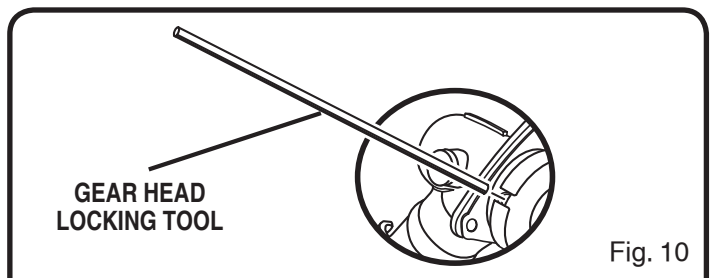

Fig. 10

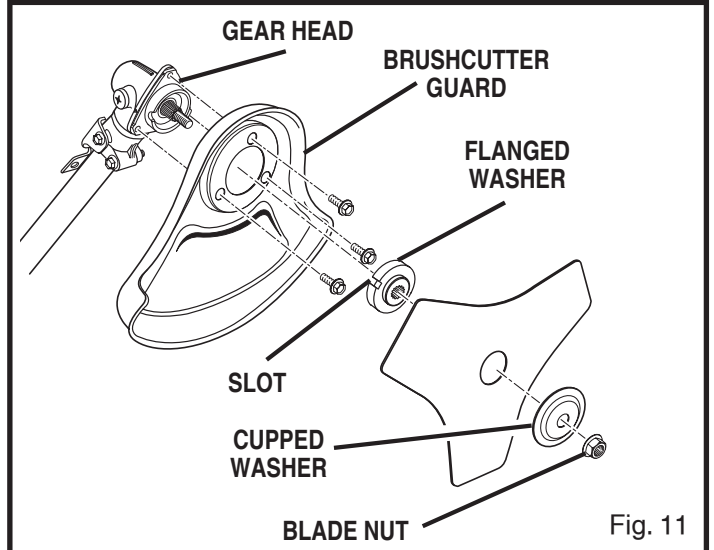

Fig. 11

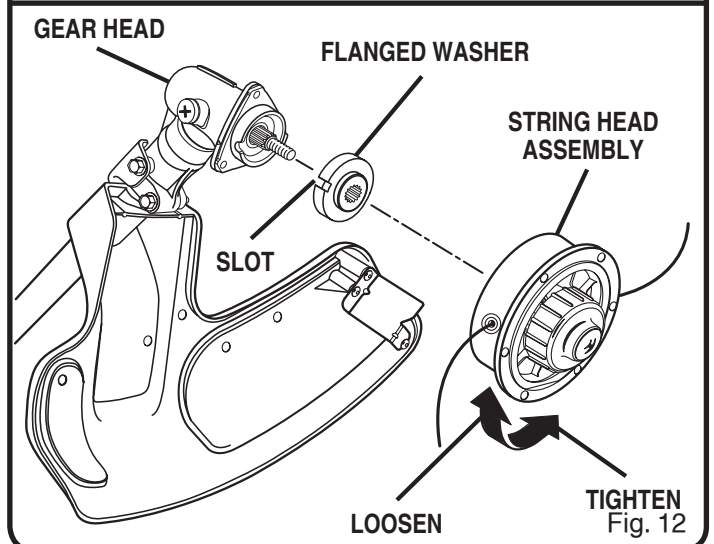

Fig. 12

ASSEMBLY

CONVERTING FROM STRING TRIMMER TO BRUSHCUTTER - BC30

To convert from the string trimmer to the brushcutter, remove the string head assembly and straight shaft grass deflector, attach the brushcutter guard and install the blade.

REMOVING THE STRAIGHT SHAFT GRASS DEFLECTOR AND STRING HEAD

See Figures 10 - 13.

1. Align the slot in the flanged washer with the slot in the gear head.
2. Place the gear head locking tool through the slot in the flanged washer and gear head.
3. Remove the string head assembly.
4. Remove the flanged washer and retain it for the blade installation.
5. Remove the screw securing the grass deflector.
6. Remove the grass deflector.

NOTE: Store the string head parts together for later use.

INSTALLING THE TRI-ARC® BLADE AND BRUSHCUTTER GUARD

See Figures 10 - 14.

1. Install the brushcutter guard. Refer to "Attaching the Brushcutter Guard" earlier in this manual.
2. Place the flanged washer over the gear head shaft with the hollow side toward the brushcutter guard.
3. Center the blade on the flanged washer, making sure the blade fits flat and the raised hub of the flanged washer goes through the hole in the blade.
4. Install the cupped washer with the raised center away from the blade.
5. Place the blade nut onto the gear head shaft.
6. Place the gear head locking tool through the slot in the flanged washer and gear head.
7. Install the blade nut by turning it counterclockwise (left handed threads).
8. Tighten the blade nut securely and torque to 120 in.lbs. minimum (finger tight plus 1/2 turn).

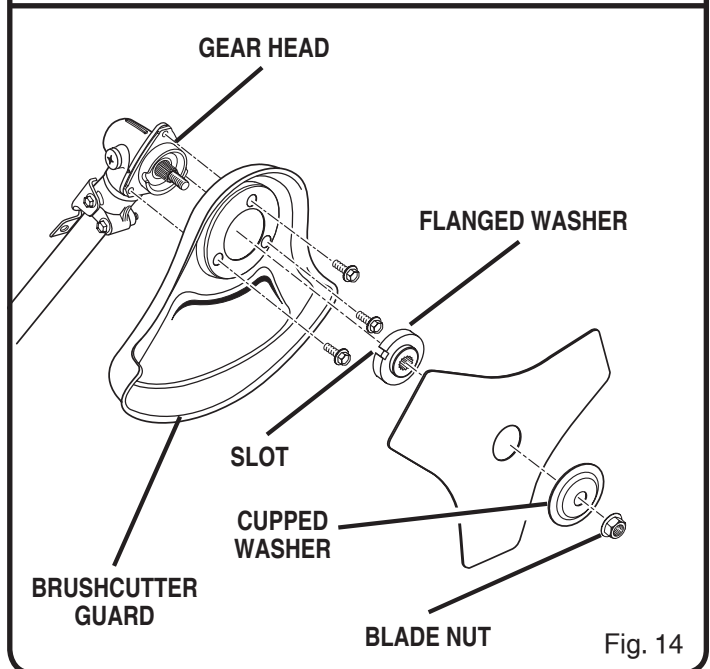
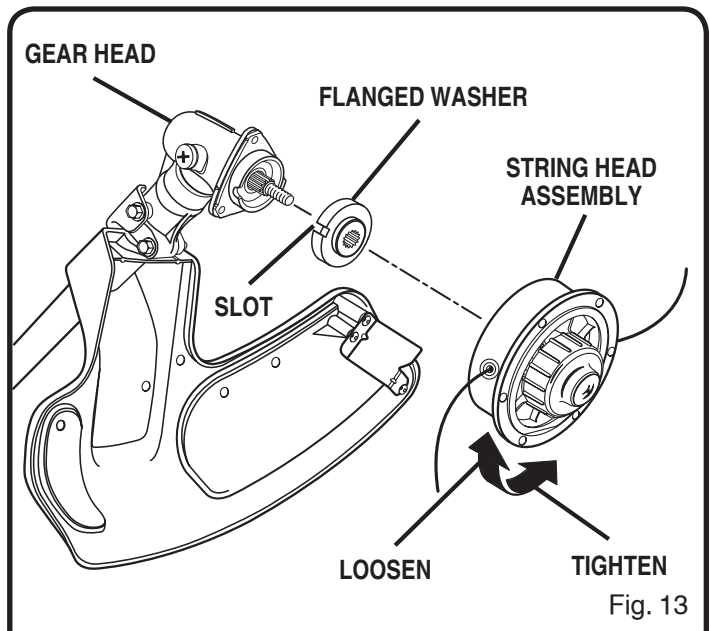

OPERATION

FUELING AND REFUELING THE TRIMMER

FUEL MIXTURE

This product is powered by a 2-cycle engine and requires pre-mixing gasoline and 2-cycle oil. Pre-mix unleaded gasoline and 2-cycle engine oil in a clean 1 gallon container approved for gasoline.

Recommended fuel: This engine is certified to operate on unleaded gasoline intended for automotive use.

Mix a high quality 2-cycle engine oil at 2.6 oz. per gallon (US).

Do not use automotive oil or 2-cycle outboard oil.

DO NOT mix quantities larger than usable in a 30 day period.

HIGH QUALITY 2-CYCLE ENGINE OIL

GASOLINE	OIL
1 gallon (US)	2.6 oz.
1 Liter	20 cc (20 ml)

FILLING TANK

1. Clean surface around fuel cap to prevent contamination.
2. Loosen fuel cap slowly. Rest the cap on a clean surface.
3. Carefully pour fuel into the tank. Avoid spillage.
4. Prior to replacing the fuel cap, clean and inspect the gasket.
5. Immediately replace fuel cap and hand tighten. Wipe up any fuel spillage.

NOTE: It is normal for smoke to be emitted from a new engine after first use.

⚠ WARNING:

Always shut off engine before fueling. Never add fuel to a machine with a running or hot engine. Move at least 30 ft. (9 m) from refueling site before starting engine. Do not smoke!

OPERATING THE TRIMMER

See Figure 15.

⚠ WARNING:

Always position the unit on the operator's right side. The use of the unit on the operator's left side will expose the user to hot surfaces and can result in possible burn injury.

⚠ WARNING:

To avoid burns from hot surfaces, never operate unit with the bottom of the engine above waist level.

Hold the trimmer with the right hand on the rear handle and the left hand on the front handle. Keep a firm grip with both hands while in operation. Trimmer should be held at a comfortable position with the rear handle about hip height.

Always operate trimmer at full throttle. Cut tall grass from the top down. This will prevent grass from wrapping around the shaft housing and string head which may cause damage from overheating. If grass becomes wrapped around the string head, STOP THE ENGINE, disconnect the spark plug wire, and remove the grass. Prolonged cutting at partial throttle will result in oil dripping from the muffler.

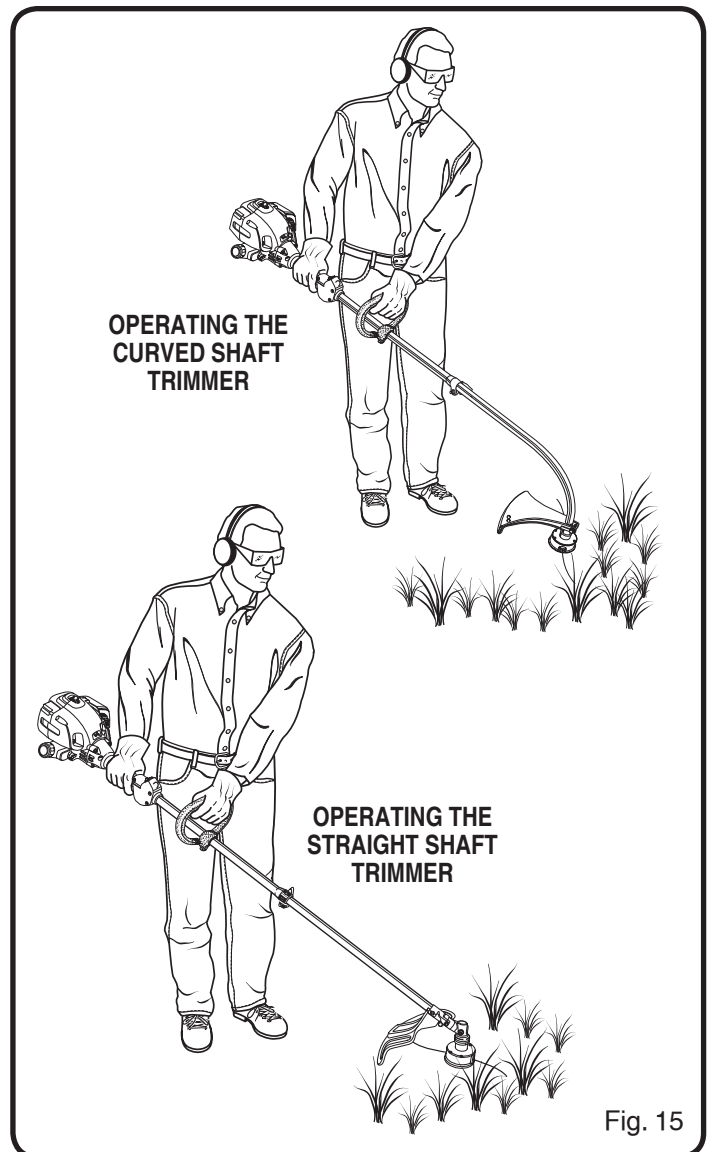

Fig. 15

OPERATION

TO ADVANCE THE CUTTING LINE

String advance is controlled by tapping the string head on grass while running engine at full throttle.

1. Run engine at full throttle.
2. Tap the spool retainer on ground to advance string. The string advances each time the spool retainer is tapped. Do not hold the spool retainer on the ground.

NOTE: The line trimming cut-off blade on the grass deflector will cut the line to the correct length.

NOTE: If the string is worn too short you may not be able to advance the string by tapping it on the ground. If so, stop the engine, and manually advance the string.

TO ADVANCE THE CUTTING LINE MANUALLY

Push the spool retainer down while pulling on string(s) to manually advance the string.

CUTTING TIPS

See Figures 16 -17.

- Keep the trimmer tilted toward the area being cut; this is the best cutting area.
- The curved shaft trimmer cuts when passing the unit from right to left. The straight shaft trimmer cuts when passing the unit from left to right. This will avoid throwing debris at the operator. Avoid cutting in the dangerous area shown in illustration.
- Use the tip of string to do the cutting; do not force string head into uncut grass.
- Wire and picket fences cause extra string wear, even breakage. Stone and brick walls, curbs, and wood may wear string rapidly.
- Avoid trees and shrubs. Tree bark, wood moldings, siding, and fence posts can easily be damaged by the string.

GRASS DEFLECTOR LINE TRIMMING CUT-OFF BLADE

See Figure 18.

The trimmer is equipped with a line trimming cut-off blade on the grass deflector. For best cutting, advance string until it is trimmed to length by the cut-off blade. Advance the string whenever you hear the engine running faster than normal, or when trimming efficiency diminishes. This will maintain best performance and keep the string long enough to advance properly.

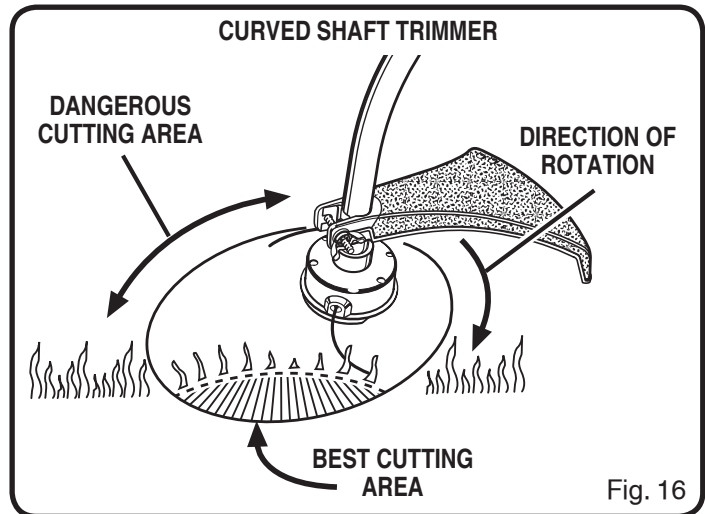

Fig. 16

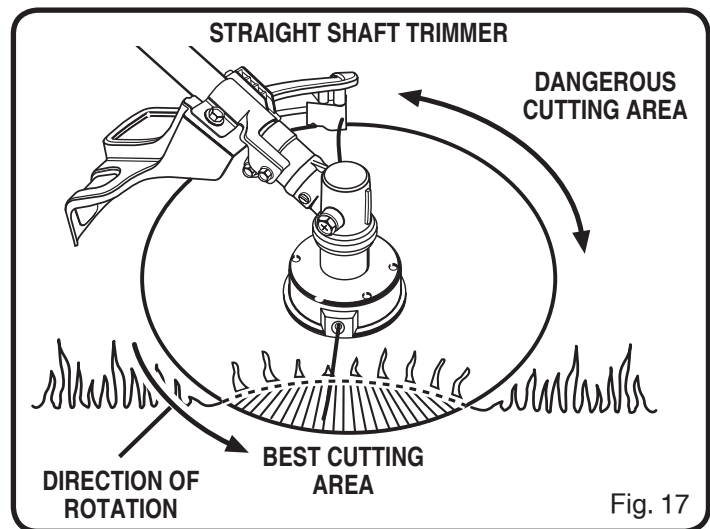

Fig. 17

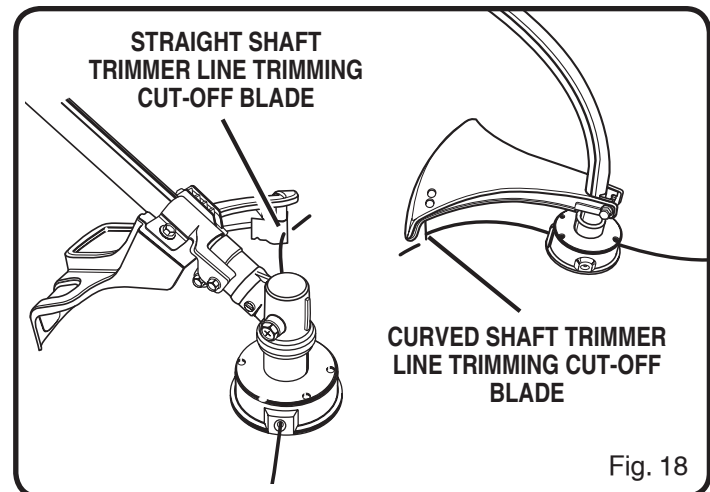

Fig. 18

OPERATION

OPERATING THE BRUSHCUTTER

See Figures 19 - 20.

Hold the brushcutter with the right hand on the rear handle and the left hand on the "J" Barrier Handle. Keep a firm grip with both hands while in operation. Brushcutter should be held at a comfortable position with the rear handle about hip height. Maintain your grip and balance on both feet. Position yourself so that you will not be drawn off balance by the kickback reaction of the cutting blade.

Adjust the shoulder harness to position the brushcutter at a comfortable operating position and to assure that the shoulder harness will reduce the risk of operator contact with the blade.

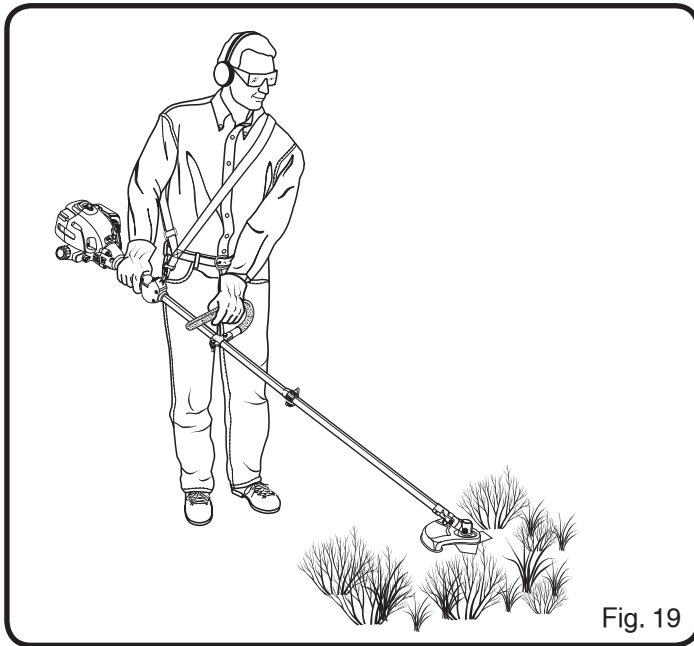

BLADE THRUST

Exercise extreme caution when using the blade with this unit. Blade thrust is the reaction that may occur when the spinning blade contacts anything it cannot cut. This contact may cause the blade to stop for an instant, and suddenly "thrust" the unit away from the object that was hit. This reaction can be violent enough to cause the operator to lose control of the unit. Blade thrust can occur without warning if the blade snags, stalls, or binds. This is more likely to occur in areas where it is difficult to see the material being cut. For cutting ease and safety, approach the weeds being cut with the brushcutter, from the right to the left. In the event an unexpected object or woody stock is encountered, this practice could minimize the blade thrust reaction.

WARNING:

To avoid burns from hot surfaces, never operate unit with the bottom of the engine above waist level.

TRI-ARC® BLADE

The Tri-Arc® blade is suited only for thicker weeds and pulpy stalks. When the blade becomes dull, it can be turned over to extend the life of the blade. Do not sharpen the Tri-Arc® blade.

Use only Tri-Arc® blade, part number AP04105, available at your local retailer.

CUTTING TECHNIQUE - BLADE

WARNING:

Extreme care must be taken when using blades to ensure safe operation. Read the safety information for safe operation using the blade, refer to "Specific Safety Rules for Brushcutter and Blade Use" earlier in this manual.

- Always hold brushcutter on your right side with both hands when operating. Use a firm grip on both handles.
- Maintain your grip and balance on both feet. Position yourself so that you will not be drawn off balance by the kickback reaction of the cutting blade.
- Inspect and clear the area of any hidden objects such as glass, rocks, concrete, fencing, wire, wood, metal, etc.
- Never use blades near sidewalks, fencing, posts, buildings or other immovable objects.
- Never use a blade after hitting a hard object without first inspecting it for damage. Do not use if any damage is detected.
- The unit is used as a scythe, cutting from the right to the left in a broad sweeping action from side to side.
- Use only the Tri-Arc® blade. To install any other brand blade or cutting head to this brushcutter can result in serious personal injury.

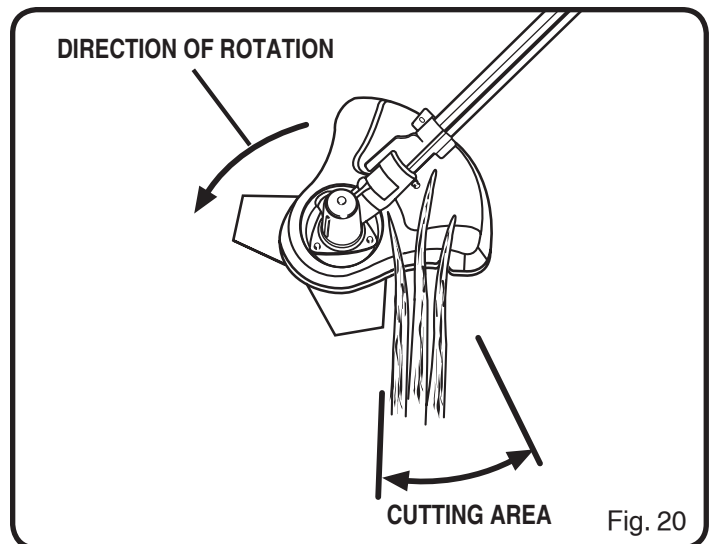

OPERATION

STARTING AND STOPPING

See Figures 21 - 23.

TO START A COLD ENGINE:

DO NOT squeeze the throttle trigger until the engine starts and runs.

- Lay the trimmer on a flat, bare surface.
- **PRIME** - Press the primer bulb 7 times.
- **SET** the start lever to the **START** position.
- **PULL** the rope until the engine starts.
- Allow the engine to run for 15 seconds.
- Squeeze trigger lock and throttle trigger.

NOTE: Squeezing the throttle trigger releases the start lever to the **RUN** position.

TO START A WARM ENGINE:

PULL the rope until the engine starts.

TO STOP THE ENGINE:

Press and hold the switch in the stop "STOP" position until the engine stops.

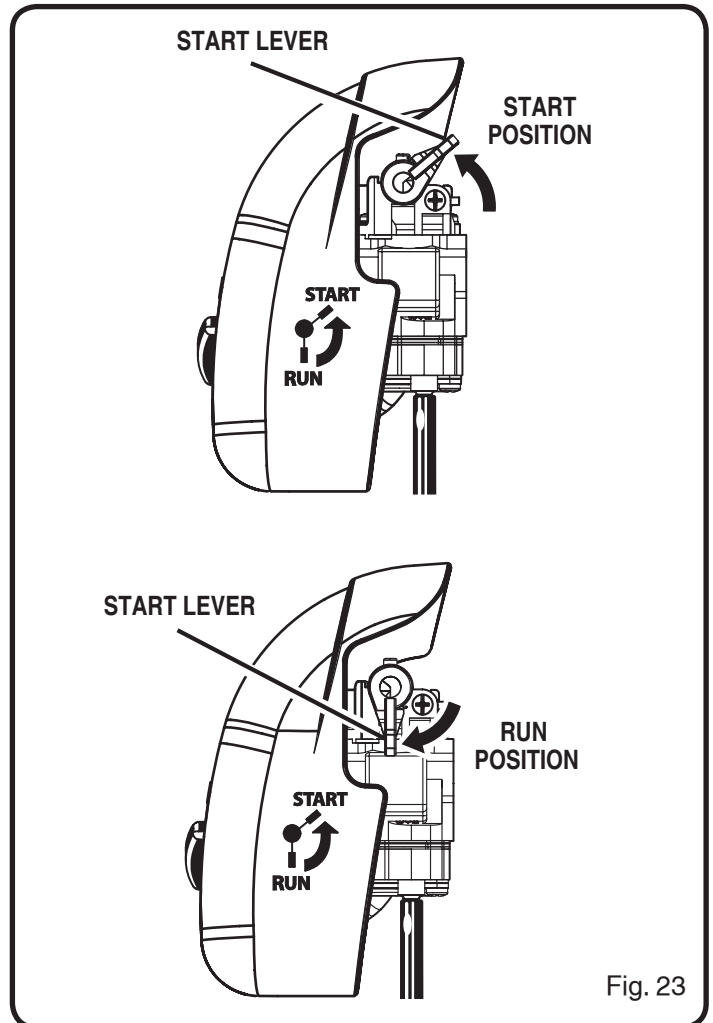
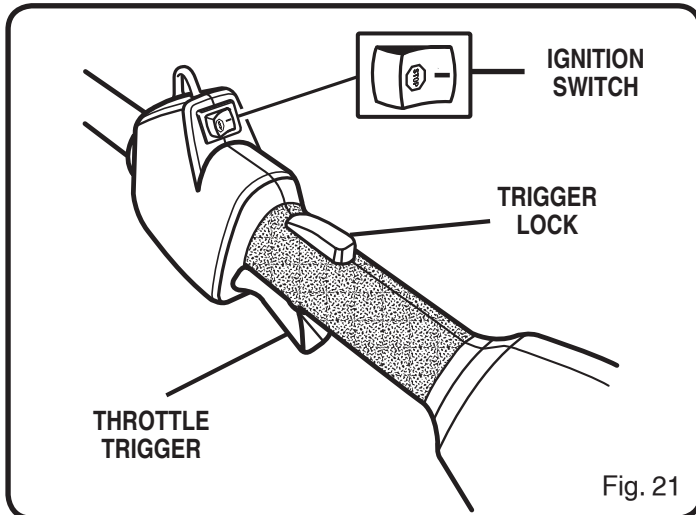
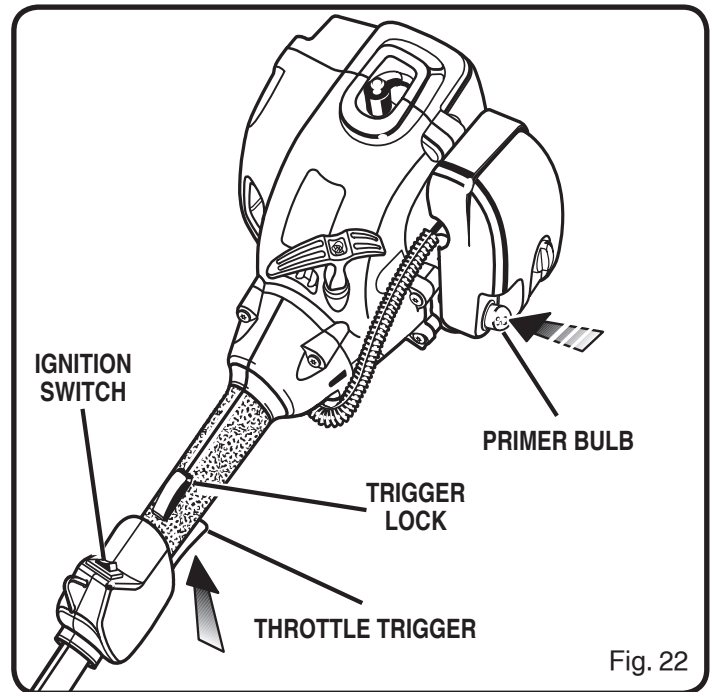

MAINTENANCE

⚠ WARNING:

Use only original manufacturer's replacement parts, accessories and attachments. Failure to do so can cause poor performance, possible injury and may void your warranty.

You can often make adjustments and repairs described here. For other repairs, have the trimmer serviced by an authorized service dealer.

SPOOL REPLACEMENT

NEW PREWOUND SPOOL

See Figures 24 - 25.

If replacing string only, refer to "String Replacement" later in this manual.

Use only monofilament string. Use original manufacturer's replacement string for best performance.

String Diameter:

CS30 - .080 in. (2.0 mm)

SS30 - .095 in. (2.4 mm)

BC30 - .095 in. (2.4 mm)

1. Stop the engine, disconnect the spark plug wire. Hold the string head and unscrew the spool retainer.

To remove the spool retainer:

Turn the spool retainer counterclockwise for models CS30.

Turn the spool retainer clockwise for models SS30 and BC30.

2. Remove the empty spool from the string head. Keep the spring attached to the spool.
3. To install the new spool, make sure the two strings are captured in the slots opposite each other on the new spool. Make sure the ends of each string is extended approximately 6 in. (152 mm) beyond each slot.
4. Thread the strings into the eyelets in the string head. Carefully push the spool into the string head (gently pull the strings to the outside if necessary). When the spool is positioned in the string head, grasp the strings and pull sharply to release them from the slots in the spool.
5. Push down and turn the spool counterclockwise until it no longer turns. Hold the spool down and rotate clockwise a small amount. Release the spool. The spool should be locked down in the string head. If not, hold down and rotate until locked.

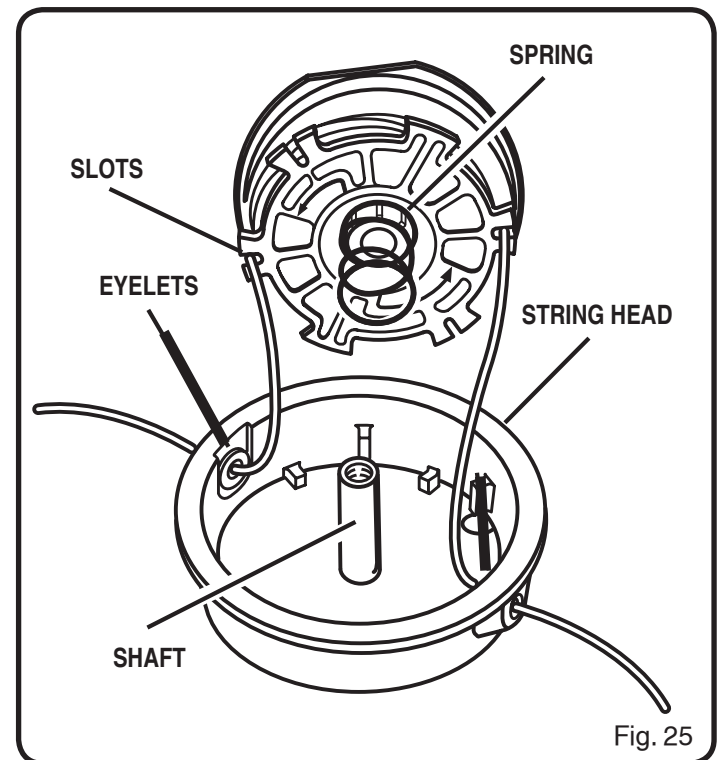
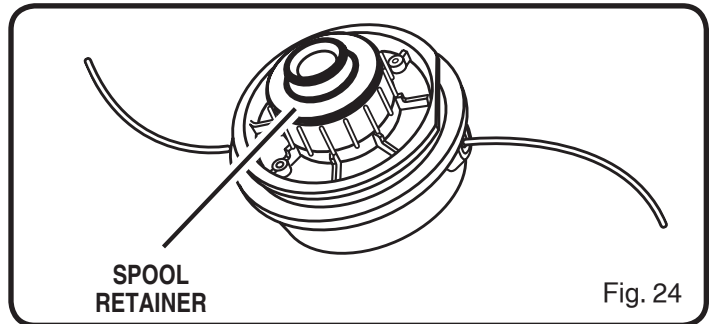

6. Make sure the string head and the spool retainer are installed on the drive shaft.

To install the spool retainer:

Turn the spool retainer clockwise for models CS30.

Turn the spool retainer counterclockwise for models SS30 and BC30.

7. Pull the strings again to rotate the spool into cutting position. Push the spool retainer down while pulling on string(s) to manually advance the string and to check for proper assembly of the string head.

MAINTENANCE

STRING REPLACEMENT

See Figures 26 - 28.

Use only monofilament string. Use original manufacturer's replacement string for best performance.

String Diameter:

CS30 - .080 in. (2.0 mm)

SS30 - .095 in. (2.4 mm)

BC30 - .095 in. (2.4 mm)

1. Stop the engine, disconnect the spark plug wire. Hold the string head and unscrew the spool retainer.

To remove the spool retainer:

Turn the spool retainer counterclockwise for models CS30.

Turn the spool retainer clockwise for models SS30 and BC30.

2. Remove the spool from the string head.

NOTE: Keep the spring attached to the spool. Remove any old string remaining on the spool.

3. Cut two pieces of string, each being approximately 9 ft. (2.7 m) long.

4. Insert the first string into the anchor hole in the upper part of the spool. Wind the first string around the upper part of the spool counterclockwise, as shown by the arrows on the spool. Place string in the slot on upper spool flange, leaving about 6 in. (152 mm) extended beyond the slot. Do not overfill. After winding the string, there should be at least 1/4 in. (6 mm) between the wound string and the outside edge of the spool.

5. Repeat above step with second string, using the bottom part of spool. Do not overfill.

6. Replace the spool and the spool retainer. Refer to "Spool Replacement" earlier in this manual.

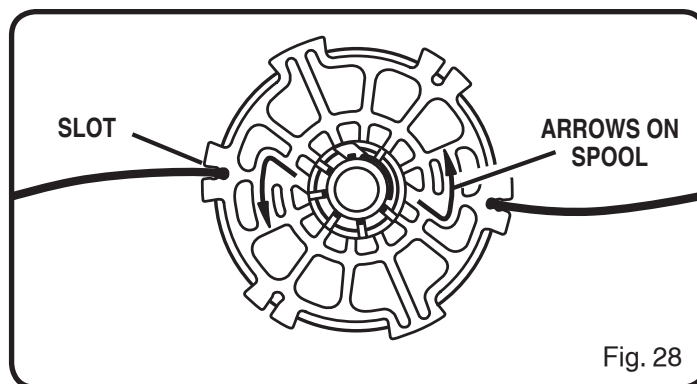
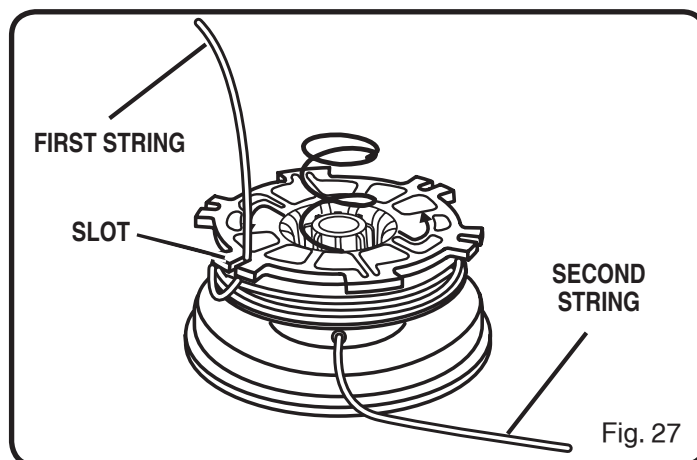
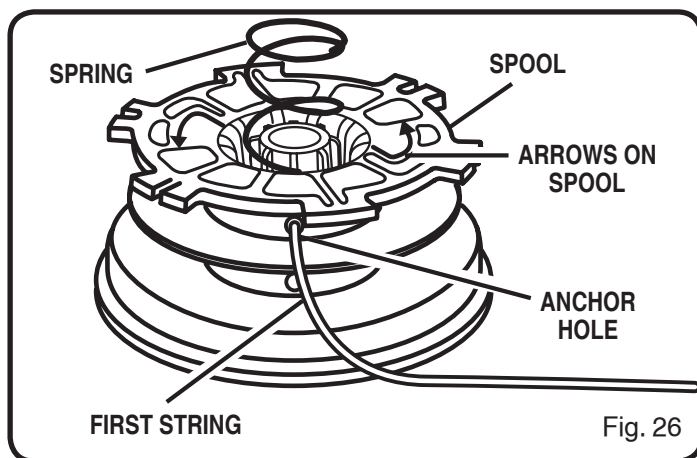

MAINTENANCE

CLEANING THE EXHAUST PORT AND MUFFLER

NOTE: Depending on the type of fuel used, the type and amount of oil used, and/or your operating conditions, the exhaust port, muffler, and/or spark arrestor screen may become blocked with carbon deposits. If you notice a power loss with your gas powered tool, you may need to remove these deposits to restore performance. We highly recommended that only qualified service technicians perform this service.

SPARK ARRESTOR

The spark arrestor must be cleaned or replaced every 25 hours or yearly to ensure proper performance of your product. Spark arrestors may be in different locations depending on the model purchased. Please contact your nearest service dealer for the location of the spark arrestor for your model.

REPLACING AND CLEANING AIR FILTER

See Figures 29 - 30.

For proper performance and long life, keep air filter clean.

1. Remove the air filter cover by turning the knob counterclockwise while gently pulling on the cover.
2. Remove the air filter, clean it in warm soapy water. Rinse and let dry completely. For best performance, replace annually.
3. Install the air filter. Align and install the air filter cover on the air filter base. Secure the air filter cover by turning the knob clockwise.

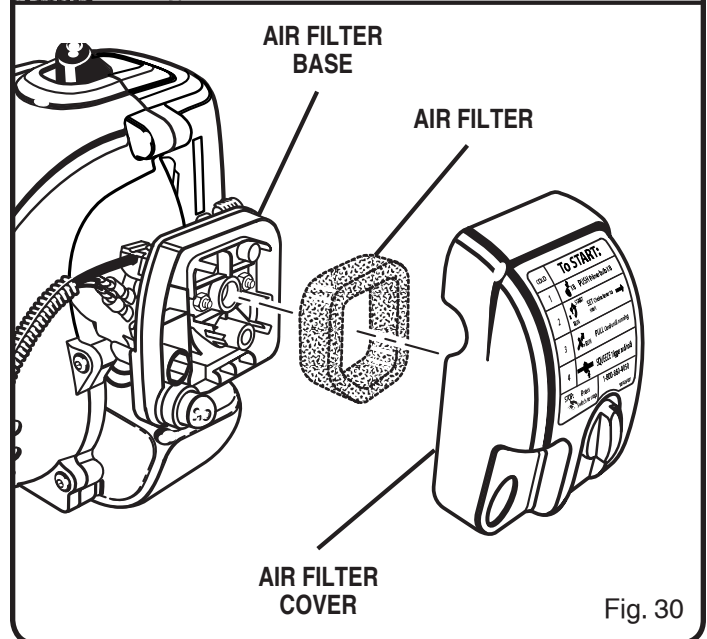
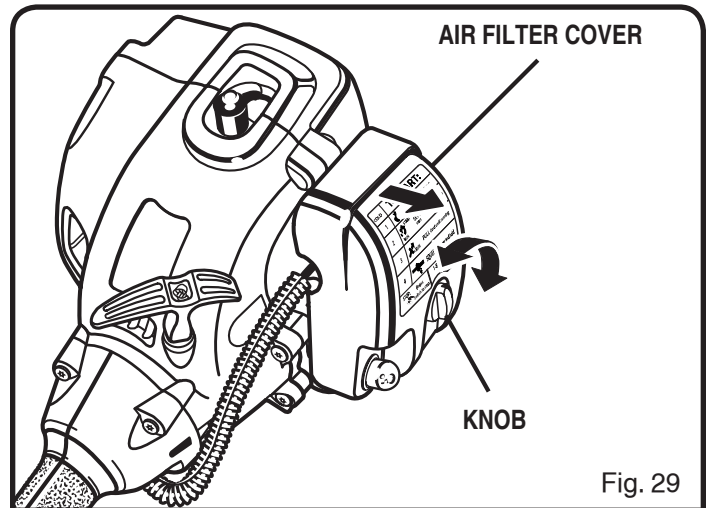

FUEL CAP

WARNING:

A leaking fuel cap is a fire hazard and must be replaced immediately.

The fuel cap contains a non-serviceable filter and a check valve. A clogged fuel filter will cause poor engine performance. If performance improves when the fuel cap is loosened, check valve may be faulty or filter clogged. Replace fuel cap if required.

SPARK PLUG

This engine uses a Champion RCJ-6Y or NGK BPMR7A spark plug with 0,63 mm (.025 in.) electrode gap. Use an exact replacement and replace annually.

STORAGE (1 MONTH OR LONGER)

1. Drain all fuel from tank into a container approved for gasoline. Run engine until it stops.
2. Clean all foreign material from the trimmer. Store it in a well-ventilated place that is inaccessible to children. Keep away from corrosive agents such as garden chemicals and de-icing salts.
3. Abide by all ISO and local regulations for the safe storage and handling of gasoline. Excess fuel should be used up in other 2-cycle engine powered equipment.

TROUBLESHOOTING

IF THESE SOLUTIONS DO NOT SOLVE THE PROBLEM CONTACT YOUR AUTHORIZED SERVICE DEALER.

PROBLEM	POSSIBLE CAUSE	SOLUTION
Engine will not start:	<ol style="list-style-type: none"> 1. No spark. 2. No fuel. 3. Engine is flooded. 	<ol style="list-style-type: none"> 1. Check spark. Remove spark plug. Reattach the spark plug cap and lay spark plug on metal cylinder. Pull the rope and watch for spark at spark plug tip. If there is no spark, repeat test with a new spark plug. 2. Push primer bulb until bulb is full of fuel. If bulb does not fill, primary fuel delivery system is blocked. Contact a service dealer. If primer bulb fills, engine may be flooded, proceed to next item. 3. Squeeze the trigger and pull the rope repeatedly until the engine starts and runs. NOTE: Depending on the severity of the flooding, this may require numerous pulls of the rope.
Engine does not reach full speed and emits excessive smoke:	<ol style="list-style-type: none"> 1. Incorrect oil/fuel mixture. 2. Air filter is dirty. 3. Spark arrestor screen is dirty. 4. Spark plug fouled. 	<ol style="list-style-type: none"> 1. Use fresh fuel and the correct 2-cycle oil mix. (50:1). 2. Clean air filter. Refer to "Replacing and Cleaning Air Filter" earlier in this manual. 3. Contact a servicing dealer. 4. Clean or replace spark plug. Reset spark plug gap. Refer to "Spark Plug Replacement" earlier in this manual.
Engine starts, runs, and accelerates but will not idle:	<ol style="list-style-type: none"> 1. Idle speed screw on carburetor needs adjustment. 	<ol style="list-style-type: none"> 1. Turn idle speed screw clockwise to increase idle speed. See Figure 31.
String will not advance:	<ol style="list-style-type: none"> 1. String is welded to itself. 2. Not enough string on spool. 3. String is worn too short. 4. String is tangled on spool. 5. Engine speed is too slow. 	<ol style="list-style-type: none"> 1. Lubricate string with silicone spray. 2. Install more string. Refer to "String Replacement" earlier in this manual. 3. Pull strings while alternately pressing down on and releasing spool retainer. 4. Remove string from spool and rewind Refer to "String Replacement" earlier in this manual. 5. Advance string at full throttle.

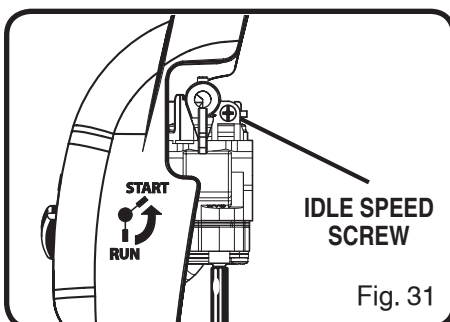

TROUBLESHOOTING

IF THESE SOLUTIONS DO NOT SOLVE THE PROBLEM CONTACT YOUR AUTHORIZED SERVICE DEALER.

PROBLEM	POSSIBLE CAUSE	SOLUTION
Spool retainer hard to turn:	1. Screw threads are dirty or damaged.	1. Clean threads and lubricate with grease - if no improvement, replace the spool retainer.
Grass wraps around driveshaft housing and string head:	1. Cutting tall grass at ground level. 2. Operating trimmer at part throttle.	1. Cut tall grass from the top down to prevent wrapping. 2. Operate trimmer at full throttle.



CALL US FIRST

For any questions about operating or maintaining your trimmer, or brushcutter call the Ryobi® Help Line!

Your trimmer has been fully tested prior to shipment to ensure your complete satisfaction.

WARRANTY

THE FOLLOWING CARB STATEMENT ONLY APPLIES TO MODEL NUMBERS REQUIRED TO MEET (CARB) REQUIREMENTS.

RYOBI TECHNOLOGIES INC. LIMITED WARRANTY FEDERAL AND CALIFORNIA EMISSION CONTROL SYSTEMS NONROAD AND SMALL OFF-ROAD ENGINES

The U.S. Environmental Protection Agency (EPA), the California Air Resources Board (CARB), and Ryobi Technologies Inc. are pleased to explain the Emission Control System Warranty on your nonroad or small off-road engine. In California, new small off-road engines must be designed, built and equipped to meet the state's stringent anti-smog standards. In other states, new 2000 and later model year nonroad engines must be designed, built and equipped, at the time of sale, to meet the U.S. EPA regulations for small nonroad engines. The nonroad engine must be free from defects in materials and workmanship which cause it to fail to conform with U.S. EPA standards for the first two years of engine use from the date of sale to the ultimate purchaser. Ryobi Technologies Inc. must warrant the emission control system on your nonroad or small off-road engine for the period of time listed above provided there has been no abuse, neglect, or improper maintenance of your nonroad or small off-road engine.

Your emission control system may include parts such as the carburetor or fuel injection system, the ignition system, the catalytic converter. Also included may be hoses, belts, and connectors and other emission related assemblies.

Where a warrantable condition exists, Ryobi Technologies Inc. will repair your nonroad or small off-road engine at no cost to you, including diagnosis (if the diagnostic work is performed at an authorized dealer), parts, and labor.

MANUFACTURER'S WARRANTY COVERAGE:

The 1995 and later small off road engines are warranted for two years in California. In other states, 1997 and later model year nonroad engines are also warranted for two years. If any emission-related part on your engine is defective, the part will be repaired or replaced by Ryobi Technologies Inc. free of charge.

OWNER'S WARRANTY RESPONSIBILITIES

- (a) As the nonroad or small off-road engine owner, you are responsible for the performance of required maintenance listed in your owner's manual. Ryobi Technologies Inc. recommends that you retain all receipts covering maintenance on your nonroad or small off-road engine, but Ryobi Technologies Inc., cannot deny warranty solely for the lack of receipts or for your failure to ensure the performance of all scheduled maintenance. Any replacement part or service that is equivalent in performance and durability may be used in non-warranty maintenance or repairs, and shall not reduce the warranty obligations of the engine manufacturer.
- (b) As the nonroad or small off-road engine owner, you should be aware, however, that Ryobi Technologies Inc., may deny you warranty coverage if your nonroad or small off-road engine or a part has failed due to abuse, neglect, improper maintenance or unapproved modifications.
- (c) You are responsible for presenting your nonroad or small off-road engine to a Ryobi Technologies Inc., service dealer as soon as a problem exists. The warranty repairs should be completed in a reasonable amount of time, not to exceed 30 days.

If you have any questions regarding your warranty rights and responsibilities, you should contact a Ryobi Technologies Inc., Customer Representative at 1-800-860-4050.

COVERAGE:

Ryobi Technologies Inc. warrants to the ultimate purchaser and each subsequent purchaser that your nonroad or small off-road engine will be designed, built and equipped, at the time of sale, to meet all applicable regulations. Ryobi Technologies Inc. also warrants to the initial purchaser and each subsequent purchaser that your nonroad or small off-road engine is free from defects in materials and workmanship which cause the engine to fail to conform with applicable regulations for a period of two years. The 1995 and later small off road engines are warranted for two years in California. In all other states for 1997 and later model years, EPA requires manufacturers to warrant non-road engines for two years. These warranty periods will begin on the date the nonroad or small off-road engine is purchased by the initial purchaser. If any emission-related part on your engine is defective, the part will be replaced by Ryobi Technologies Inc. at no cost to the owner.

Ryobi Technologies Inc. shall remedy warranty defects at any authorized Ryobi Technologies Inc. engine dealer or warranty station. Any authorized work done at an authorized dealer or warranty station shall be free of charge to the owner if such work determines that a warranted part is defective. Any manufacturer-approved or equivalent replacement part may be used for any warranty maintenance or repairs on emission-related parts, and must be provided free of charge to the owner if the part is still under warranty. Ryobi Technologies Inc. is liable for damages to other engine components caused by the failure of a warranted part still under warranty.

The California Air Resources Board's Emission Warranty Parts List specifically defines the emission-related warranted parts. (EPA's regulations do not include a parts list, but EPA considers emission-related warranted parts to include all the parts listed below.)

These warranted parts are: Carburetor, Spark Plug, Ignition, Air Filter and Fuel Filter.

MAINTENANCE REQUIREMENTS

The owner is responsible for the performance of the required maintenance as defined by Ryobi Technologies Inc. in the operator's manual.

LIMITATIONS

The Emission Control Systems Warranty shall not cover any of the following:

- (a) repair or replacement required because of misuse or neglect, lack of required maintenance, repairs improperly performed or replacements not conforming to Ryobi Technologies Inc. specifications that adversely affect performance and/or durability, and alterations or modifications not recommended or approved in writing by Ryobi Technologies Inc., and
- (b) replacement of parts and other services and adjustments necessary for required maintenance at and after the first scheduled replacement point.

WARRANTY

EMISSIONS MAINTENANCE SCHEDULE AND WARRANTED PARTS LIST

Emissions Parts	Inspect Before Each Use	Clean Every 5 Hours	Replace Every 25 Hours or Yearly
-----------------	----------------------------	------------------------	-------------------------------------

AIR FILTER ASSY

INCLUDES:

FILTER..... X X

CARBURETOR ASSY

INCLUDES:

HEAT DAM

GASKETS

FUEL TANK ASSY

INCLUDES:

FUEL LINESX

FUEL CAPX

FUEL FILTER

IGNITION ASSY

INCLUDES:

SPARK PLUG..... X

ALL EMISSIONS - RELATED PARTS ARE WARRANTED FOR TWO YEARS OR FOR THE PERIOD OF TIME PRIOR TO THE PARTS FIRST SCHEDULED REPLACEMENT WHICH EVER COMES FIRST.



OPERATOR'S MANUAL

30cc String Trimmers and Brushcutters

RY30000 Series

- **SERVICE**

Now that you have purchased your tool, should a need ever exist for repair parts or service, simply contact your nearest Ryobi Authorized Service Center. Be sure to provide all pertinent facts when you call or visit. Please call 1-800-860-4050 for your nearest Ryobi Authorized Service Center.

- **MODEL NO. AND SERIAL NO.**

The model number of this tool will be found on a plate attached to the motor housing. Please retype the model number and serial number in the space provided below.

- **HOW TO ORDER REPAIR PARTS**

WHEN ORDERING REPAIR PARTS,
ALWAYS GIVE THE FOLLOWING INFORMATION:

- MODEL NUMBER _____
- SERIAL NUMBER _____

RYOBI TECHNOLOGIES INC.

1428 Pearman Dairy Road Anderson, SC 29625
Post Office Box 1207 Anderson, SC 29622
Phone 1-800-860-4050

Free Manuals Download Website

<http://myh66.com>

<http://usermanuals.us>

<http://www.somanuals.com>

<http://www.4manuals.cc>

<http://www.manual-lib.com>

<http://www.404manual.com>

<http://www.luxmanual.com>

<http://aubethermostatmanual.com>

Golf course search by state

<http://golfingnear.com>

Email search by domain

<http://emailbydomain.com>

Auto manuals search

<http://auto.somanuals.com>

TV manuals search

<http://tv.somanuals.com>