

PS250 Platform Scale



User Instructions
Manuel d'utilisation
Bedienungsanleitung
Istruzioni per l'utente

MULTI-LINGUAL

©Salter Brecknell Weighing 2002. All rights reserved.

The information contained herein is the property of Salter Brecknell Weighing and is supplied without liability for errors or omissions. No part may be reproduced or used except as authorised by contract or other written permission. The copyright and the foregoing restriction on reproduction and use extend to all media in which the information may be embodied.

Contents

page no.

Declaration of Conformity

Safety

| | |
|----------------------|---|
| Warnings | 3 |
| Safe installation | 3 |
| Safe use | 3 |
| Cleaning the machine | 3 |
| EMC compliance | 4 |

1 About your machine 5

| | |
|-------------------|---|
| 1.1 Description | 5 |
| 1.2 Display | 5 |
| 1.3 Key functions | 5 |
| 1.4 Error codes | 6 |
| 1.5 Specification | 6 |
| 1.6 Power supply | 7 |

2 Weighing 8

| | |
|-------------------|----|
| 2.1 Hold function | 10 |
|-------------------|----|

3 Setup mode 12

| | |
|--------------------|----|
| 3.1 Function setup | 12 |
| 3.2 Calibration | 14 |



Declaration of Conformity

| | |
|--------------|------------------|
| Manufacturer | Salter Brecknell |
| Type | PS250 |

corresponds to the requirements of the following EC directives:

| | |
|-----------------------|----------------|
| EMC Directive | EMC 89/336/EEC |
| Low Voltage Directive | LVD 73/23/EEC |

| | |
|--|-------------------------------|
| The applicable harmonised standards are: | EN60950, EN50081-1, EN50082-1 |
|--|-------------------------------|

A copy of the original signed declaration for this instrument is available from:

Salter Brecknell Weighing, P.O. Box 9533, Smethwick, West Midlands, B66 2TE

**Déclaration de Conformité**

| | |
|-----------|------------------|
| Fabricant | Salter Brecknell |
| Type | PS250 |

Correspond aux exigences des directives CE suivantes:

| | |
|-------------------------|----------------|
| Directive CEM | CEM 89/336/EEC |
| Directive Basse Tension | LVD 73/23/EEC |

| | |
|--|-------------------------------|
| Les standards harmonisés applicables sont: | EN60950, EN50081-1, EN50082-1 |
|--|-------------------------------|

Une copie originale de la déclaration signée pour cet instrument est disponible à:

Salter Brecknell Weighing, P.O. Box 9533, Smethwick, West Midlands, B66 2TE



Konformitätserklärung

| | |
|------------|------------------|
| Hersteller | Salter Brecknell |
| Typ | PS250 |

entspricht den Anforderungen der folgenden EU-Richtlinien:

| | |
|---------------------------|----------------|
| EMV-Richtlinie | EMC 89/336/EEC |
| Niederspannungsrichtlinie | LVD 73/23/EEC |

| | |
|--|-------------------------------|
| Die angewendeten harmonisierten Normen sind: | EN60950, EN50081-1, EN50082-1 |
|--|-------------------------------|

Eine Abschrift der original unterschriebenen Konformitätserklärung ist unter unten genannter Adresse erhältlich:

Salter Brecknell Weighing, P.O. Box 9533, Smethwick, West Midlands, B66 2TE

**Dichiarazione di conformità**

| | |
|------------|------------------|
| Produttore | Salter Brecknell |
| Modello | PS250 |

è conforme alle caratteristiche previste dalle seguenti direttive CE

| | |
|---------------------------------|-----------|
| Normativa EMC | 89/336/CE |
| Normativa per la bassa tensione | 73/23/CE |

| | |
|---|----------------------------------|
| Le norme standard armonizzate applicate sono: | EN60950, EN50081-1, EN50082-1 |
|---|----------------------------------|

Se richiesto, è disponibile una copia dell'originale certificato firmato da:

Salter Brecknell Weighing, P.O. Box 9533, Smethwick, West Midlands, B66 2TE

Electromagnetic Compatibility Statement for North America

This equipment has been tested and found to comply with the limits for a Class A digital device, pursuant to Part 15 of the FCC Rules. These limits are designed to provide reasonable protection against harmful interference when the equipment is operated in a residential installation. This equipment generates, uses and can radiate radio frequency energy and if not installed and used in accordance with the instructions manual, may cause harmful interference to radio communications. Operation of this equipment in a residential area is likely to cause harmful interference in which case the user will be required to correct the interference at his/her own expense.

Safety

Warnings

Safe installation



Take care when lifting and transporting heavy objects.

Do not overload the machine. Take care not to exceed the weighing capacity of the machine.

Pluggable equipment must be installed near an easily accessible socket outlet. Permanently connected equipment must have a readily accessible disconnect device incorporated in the fixed wiring.

For your protection all mains (110V or 230V) equipment used out of doors or in wet or damp conditions should be supplied from a correctly fused source and protected by an approved RCD to BS7071 or BS7288 or BS4293.

The mains lead must be connected to a supply outlet with a **protective earth contact**. The electrical supply at the socket outlet must provide overcurrent protection of an appropriate rating.

IF IN DOUBT SEEK ADVICE FROM A QUALIFIED ELECTRICIAN.

Safe use



To avoid the possibility of electric shock or damage to the machine, always switch off the machine and isolate from the power supply before carrying out any routine maintenance.

Cleaning the machine

CAUTION: Harsh abrasives, solvents, scouring cleaners and alkaline cleaning solutions, such as washing soda, should not be used especially on the display windows. Under no circumstances should you attempt to wipe the inside of the machine.

The outside of standard products may be wiped down with a clean cloth moistened with water containing a small amount of washing up liquid or disinfectant

EMC compliance

The following warning may be applicable to your machine.



WARNING: This is a class A product. In a domestic environment this product may cause radio interference in which case the user may be required to take adequate measures.

1 About your machine

1.1 Description

The PS250 is a self contained portable platform scale with a remote display. The platform is constructed of mild steel; it has four adjustable feet for levelling and a non-slip mat for the platform. A bracket and fixings are supplied for desk or wall mounting the indicator head. For best results, always install the platform on a hard, flat, level surface.

A stainless steel platform version is available.

1.2 Display

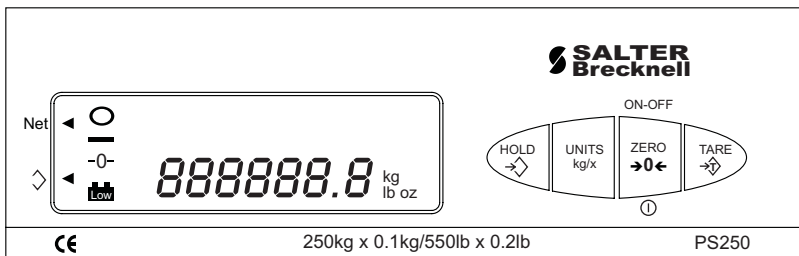

○ Stable

— Minus

-0- Centre of zero

Low Low battery

net ◀ Net weight

◊ ◀ Hold weight

lb weighing mode

kg weighing mode

1.3 Key functions



Zero/ON/OFF key. Switches the scale on or off.



Tare key. Applies a tare value



Units key

Selects weighing units



Hold key

Retains average weight display.

1.4 Error codes

Err Overload

ErrL Below zero

ErrE EEprom error



Low battery warning

1.5 Specification

Capacity/resolution 250kg x 0.1kg

550lb x 0.2lb

Display Height 25mm

7 segment LCD

Operating temperature 5° C to 35° C

Weight 22kg

Dimensions

Platform 900mm x 550mm x 50mm

Display head 270mm x 90mm x 45mm

Power supply 6 x 1.2V metal hydride rechargeable batteries

Recharge adaptor 1 x 100V-240V AC/13V DC

1.6 Power supply

The indicator head contains six metal hydride re-chargeable batteries. The low battery indicator  is displayed when the battery power is insufficient to power the scale.

Recharging the batteries

Insert the AC re-charger adapter into the socket on the indicator head to recharge the batteries.

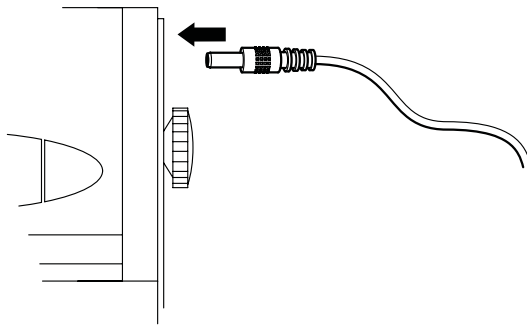

Recharging time is approximately 14 hours.

Fully charged batteries should give approximately eight hours of continuous use.

CAUTION: Always connect the AC adaptor to the indicator head before connecting to the mains power supply.

Disconnect from the mains power supply before disconnecting the adaptor from the indicator head.

AC adaptor

The 100V/240V recharge adaptor supplied with the PS250 is provided with four conversion connectors:

- 2 pin European
- 3 pin UK
- 2 pin USA
- 2 pin Australia

2 Weighing

For best results, always weigh on a hard flat and level surface. The platform has four adjustable feet for levelling.

Press  to switch on the scale. The display will show **8888** then go to weighing mode. If the display does not show

0.0 or **0** press  .

To switch off the scale, press and hold  .

1. If necessary, zero the scale.

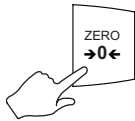

2.

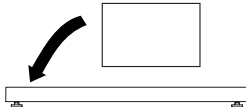

Using tares

3.

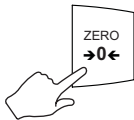

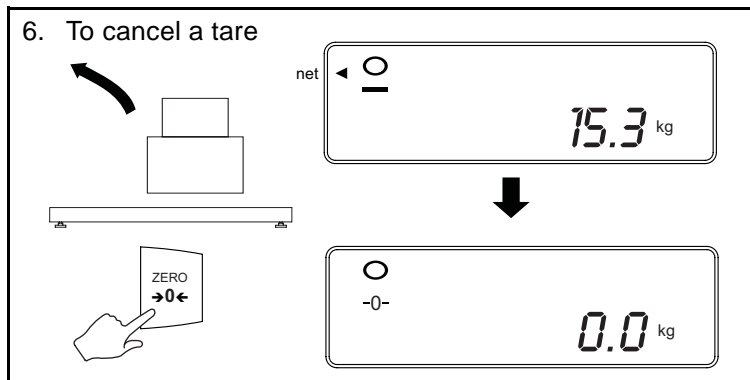
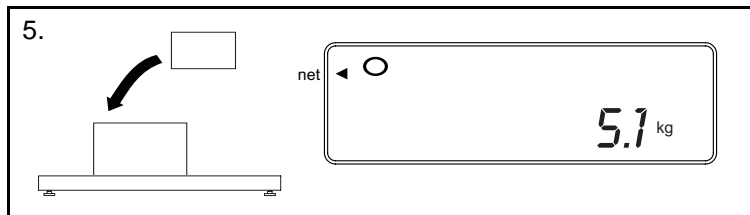
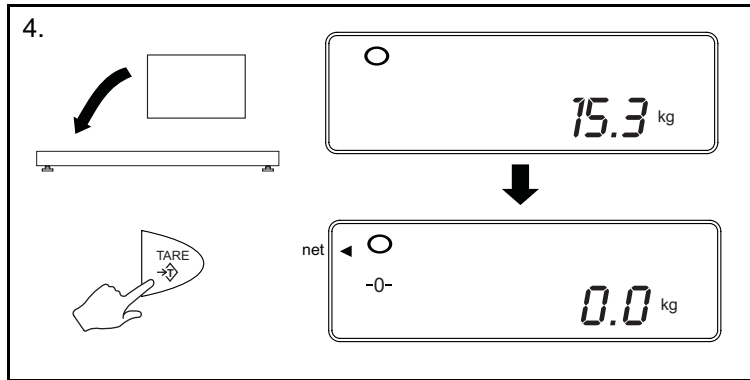

Weighing units

Press  to toggle between kg, lb and oz.

2.1 Hold function

This function enables you to weigh oversized objects that may obscure the display. The system calculates an average weight reading and displays this weight value. This makes the hold function ideal for weighing animals that may be moving around on the platform.

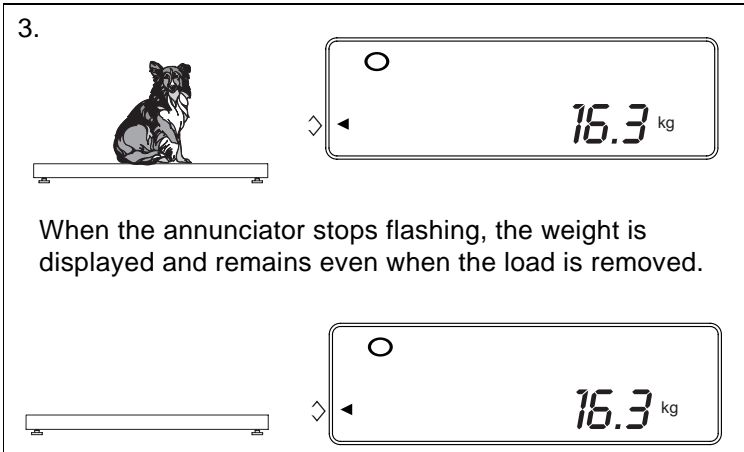
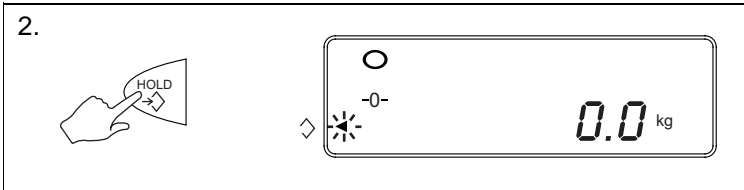
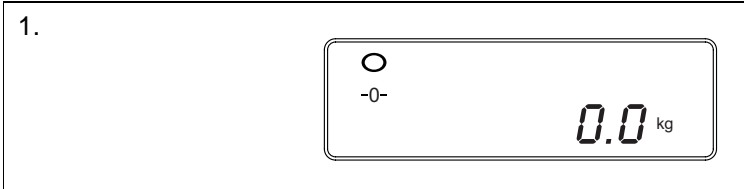

4. To cancel the hold:



3 Setup mode

3.1 Function setup

In setup mode you can configure the following functions:

- weighing unit
- auto shut-off
- calibration weight

Auto shut-off switches off the scale if no activity is sensed during the period set. The time values are in seconds. To disable auto shut-off, select *OFF*.

Calibration weight allows you to select full load, 0.5 load or 0.25 load of the machine capacity for calibration. The table lists the actual weight value you should use.



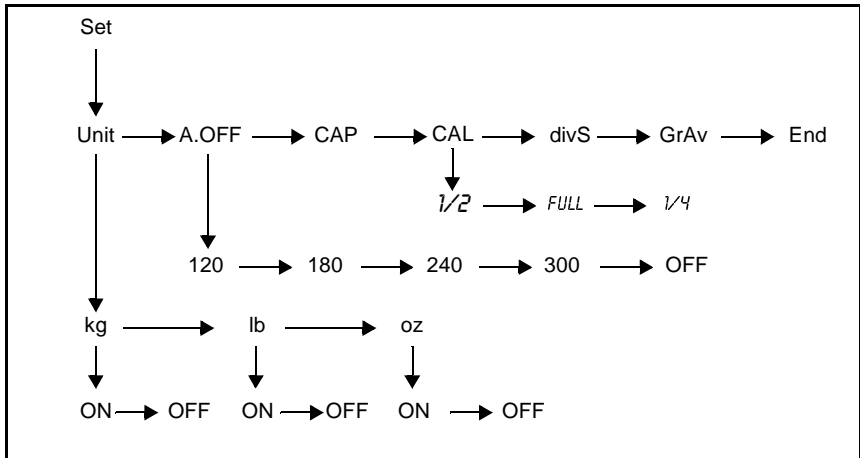

| Weighing units | Full load | 1/2 load | 1/4 load |
|----------------|-----------|----------|----------|
| kg | 200 kg | 100 kg | 50 kg |
| lb | 500 lb | 200 lb | 100 lb |

Calibration weights





Setup menu

Navigating the setup menu

1. Press and hold  until display shows *SET* (approximately three seconds).
2. Release , display shows *UNIT*.
3. Press  to move across to the option or value you require.
4. Press  to select an option and save.

To exit the setup menu and save your changes:

Press  until you see *End*.

Press  to save your changes and return to weighing mode.

3.2 Calibration

1. In setup mode, select *CR/L* and then select whether you want to use $1/2$, full or $1/4$ load for calibration (see 'Calibration weights' on page 12). The example shown in these instructions uses kg weight units and $1/2$ load. Save your selection and then switch off the scale.

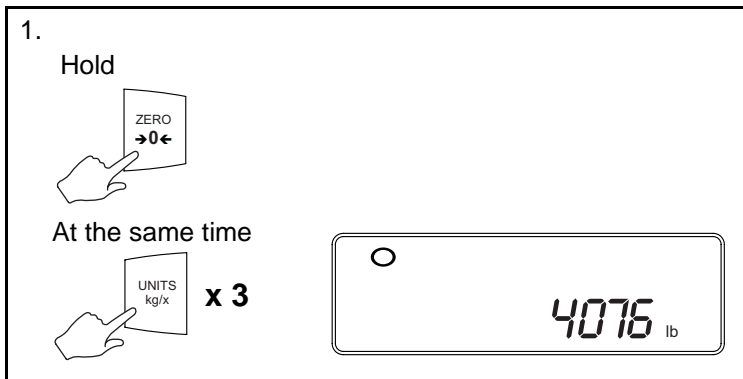

Display shows zero count value.

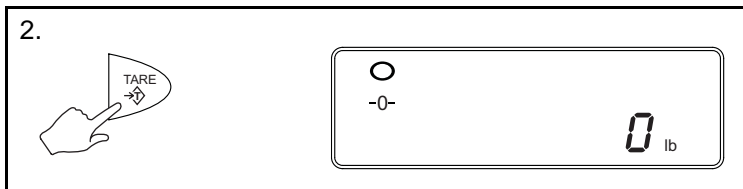

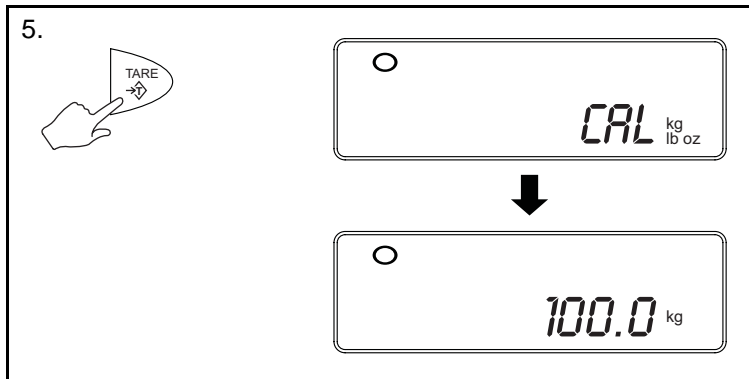
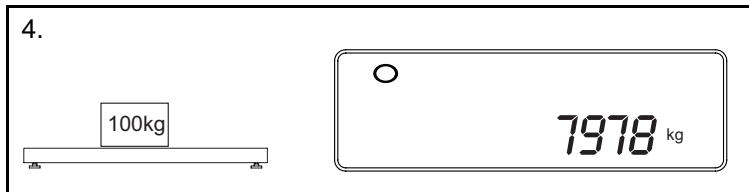
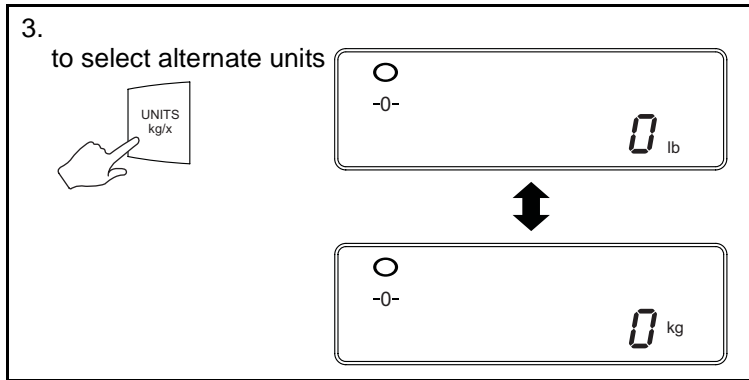



P.O. Box 9533, Smethwick,
West Midlands, B66 2TE
Tel UK: 0870 444 6132 Fax UK: 0870 010 2241

Email: sales@salterbrecknell.co.uk

Salter Brecknell Weighing,
3620 Central Avenue NE, Minneapolis,
MN 55418, USA.
Tel: 612 781 4211 Fax: 612 781 4320

Email: sales@salterbrecknell.com

Free Manuals Download Website

<http://myh66.com>

<http://usermanuals.us>

<http://www.somanuals.com>

<http://www.4manuals.cc>

<http://www.manual-lib.com>

<http://www.404manual.com>

<http://www.luxmanual.com>

<http://aubethermostatmanual.com>

Golf course search by state

<http://golfingnear.com>

Email search by domain

<http://emailbydomain.com>

Auto manuals search

<http://auto.somanuals.com>

TV manuals search

<http://tv.somanuals.com>