

Electric Control Valves/ Controller with Electric Actuator

Type 3222/5724, Type 3222/5725 and Type 3222/5757



*Type 3222/5725 Globe Valve mounted on
Controller with Electric Actuator*



*Type 3222/5757 Globe Valve mounted on
Controller with Electric Actuator*

Mounting and Operating Instructions

EB 5766 EN

Edition July 2008



Contents	Page
1	Design and principle of operation 4
1.1	Versions 4
1.2	Technical data 6
2	Installation 9
2.1	Mounting position 9
2.2	Strainer 9
2.3	Additional installation instructions 9
3	Attaching the actuator to the valve 10
3.1	Type 5757/-7 Controller with Electric Actuator 10
3.2	Type 5724/5725 Controller with Electric Actuator 10
4	Electrical connections 11
4.1	Type 5757-7 Controller with Electric Actuator. 11
4.2	Type 5757 Controller with Electric Actuator. 11
4.3	Type 5724/5725 Controller with Electric Actuator 12
5	Manual override 13
5.1	Type 5757/-7 Controller with Electric Actuator 13
5.2	Type 5724/5725 Controller with Electric Actuator 13
6	Operation 14
7	Maintenance 15
8	Dimensions in mm and weights 16
9	Appendix 18
9.1	Wiring for Type 5757-7 18
9.2	Wiring for Type 5757 20
9.3	Wiring for Type 5724/5725 22



Typetest

The Type 5725 Controller with Electric Actuators with safety function used in conjunction with Type 3222 Valves are typetested according to DIN 32730 by the German technical inspectorate TÜV.

Register number available on request.

General safety instructions



- ▶ *The control valves may only be mounted, started up or serviced by fully trained and qualified personnel, observing the accepted industry codes and practices. Make sure employees or third persons are not exposed to any danger.
All safety instructions and warnings in these mounting and operating instructions, particularly those concerning assembly, start-up and maintenance, must be observed.*
- ▶ *The control valves fulfill the requirements of the European Pressure Equipment Directive 97/23/EC. Valves with a CE marking have a declaration of conformity which includes information about the applied conformity assessment procedure. The declaration of conformity is available on request.*
- ▶ *For appropriate operation, make sure that the control valve is only used in applications where the operating pressure and temperature do not exceed the operating values which are based on the valve sizing data submitted in the order.
The manufacturer does not assume any responsibility for damage caused by external forces or any other external influence!
Any hazards which could be caused in the control valve by the process medium, the operating pressure, the signal pressure or by moving parts are to be prevented by means of the appropriate measures.*
- ▶ *Proper shipping and appropriate storage of the control valve are assumed.*

Caution!



- ▶ *For installation and maintenance, make sure the relevant section of the pipeline is depressurized and, depending on the process medium, drained as well. If necessary, allow the control valve to cool down or warm up to reach ambient temperature prior to starting any work on the valve.*
- ▶ *The electric actuators have been designed for use in electrical power installations. For wiring and maintenance, you are required to observe the relevant safety regulations.*
- ▶ *Only use power interruption devices which are protected against unintentional reconnection of the power supply.*
- ▶ *Take special care when making adjustments on live parts. Do not remove any covers!*

1 Design and principle of operation

The control valves consist of a single-seated Type 3222 Globe Valve and either a Type 5757, Type 5757-7 or Type 5724 Controller with Electric Actuator or a Type 5725 Controller with Electric Actuator with safety function.

The process medium flows through the globe valve in the direction indicated by the arrow on the body. The position of the valve plug determines the flow rate over the cross-sectional area of flow released between the plug (3) and valve seat (2). The plug stem (4) with plug is connected with the stem of the actuator (10) by a force-locking connection. The valve is opened by the valve spring (5) following the retracting movement of the actuator stem. A special version is required for water above 150 °C and for steam (Fig. 1). The plug is moved by a change in the control signal acting on the actuator.

The electric actuator with safety function (Type 5725) has a spring mechanism and an electromagnet that can be connected to a safety control circuit. When the control circuit is interrupted or the power supply fails, the magnet disengages the gear from the self-locking motor and releases the spring mechanism. The valve is closed in the event of a safety situation (fail-safe action "actuator stem extends").

The electric actuators contain a digital controller integrated into the actuator. The controlled variable is recorded over the directly connected Pt 1000 sensor (see Table 2).

The output signal of the digital controller acts as a three-point stepping signal on the

synchronous motor of the actuator and is transferred over the connected gear as a positioning force onto the actuator stem.

The Type 5757, Type 5724 and Type 5725 are particularly suitable for DHW heating in instantaneous heating systems and for fixed set point control circuits in mechanical engineering applications.

Type 5757-7 is suitable for heating applications.

1.1 Versions

	PN	DN	EB ¹⁾
Electric control valve/Controller with electric actuator			
Type 3222/5757 ²⁾	25	15 to 25	5757
Type 3222/5757-7 ³⁾	25	15 to 25	5757-7
Type 3222/5724 ²⁾	25	15 to 50	5724
... with safety function			
Type 3222/5725 ²⁾	25	15 to 50	5724

- 1) Refer to the listed Mounting and Operating Instructions (EB) for details on the controllers with electric actuators
- 2) Controller with electric actuator for domestic hot water heating in instantaneous heating systems and for fixed set point control circuits in mechanical engineering applications
- 3) Controller with electric actuator for heating applications

- 1 Valve body
- 2 Seat
- 3 Plug
- 4 Plug stem
- 5 Valve spring
- 6 Guide nipple
- 7 Balancing bellows
- 8 Balancing piston
- 10 Controller with electric actuator

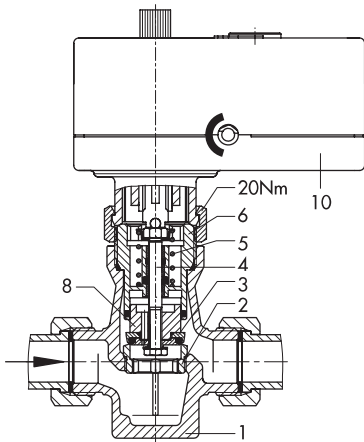

Type 3222/5757

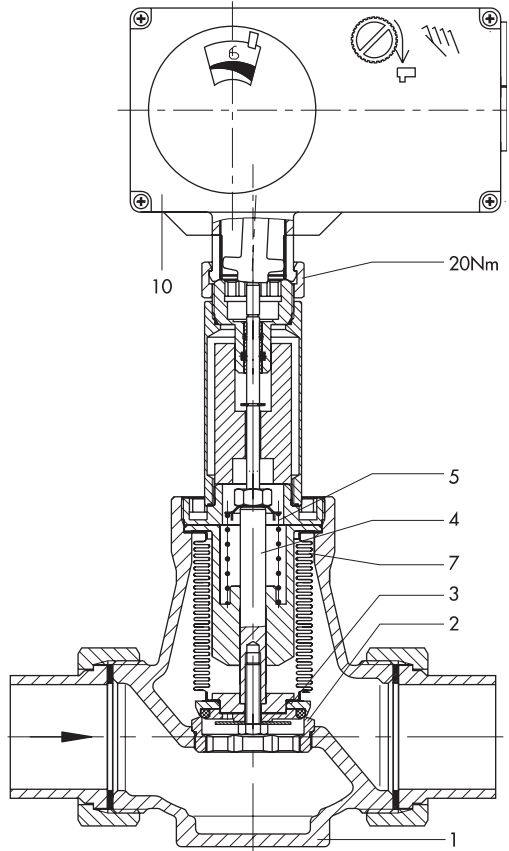

Type 3222/5724
Special version for temperatures up to 200 °C and
with plug balanced by a bellows

Fig. 1 - Type 3222/5757 and Type 3222/5724 Electric Control Valves/Controller with Electric Actuator

1.2 Technical data

1. Single-seated Type 3222 Globe Valve

Nominal size	DN	15	20	25	32	40	50
Version	with threaded ends with flanges as flanged body	•	•	•	•	•	•
Thread size	G	½	¾	1	–	–	–
Version with female thread		•	•	•	–	–	–
Nominal pressure	PN	25					
Seat/plug sealing		Metal sealing for $K_{VS} \leq 2.5$ · Soft sealing for $K_{VS} \geq 3.6$					
Rated travel	mm	6			12		
Rangeability		50 : 1					
Leakage class acc. to DIN EN 1349		Class I (< 0.05 % of K_{VS} coefficient)					
Version for water, oil and other liquids							
Max. permissible temperature		150 °C ^{1,2)}					
Max. permissible differential pressure Δp in bar							
	Types 5724 and 5725	20			12		
	Type 5757	20			–		
Version for water and steam							
Max. permissible temperature		200 °C					
Max. permissible differential pressure Δp in bar							
	Types 5724 and 5725	20 · 10 for $3.6 \leq K_{VS} \leq 8$			8		
	Type 5757	20 ³⁾ · 5 ⁴⁾	5		–		
Materials							
Valve body		Red brass CC491K · EN-JS1049 (flanged body)					
Seat		Stainless steel 1.4104					
Plug		1.4104/CW509L with soft sealing · 1.4104 for $0.1 \leq K_{VS} \leq 2.5$					
Valve spring		Stainless steel 1.4310 K					
Packing		EPDM/FPM (FKM) · Oil-resistant version: FPM					
Welding ends		St 37					
Threaded ends		Red brass CC491K					
Screwed-on flanges		St 37.2					

Nominal size	DN	15	20	25	32	40	50
Thread size	G	½	¾	1	–	–	–
K _{VS} coefficients							
Version with female thread		3.6	5.7	7.2	–	–	–
Version with male thread		4	6.3	8	16	20	25
Reduced K _{VS} coefficients		0.1 · 0.16 · 0.25 · 0.4 0.63 · 1.0 · 1.6 · 2.5	1.0 · 1.6 · 2.5 4 ⁵⁾ · 3.6 ⁶⁾		–	–	–
Rated travel	mm	6			12		

- 1) Use an intermediate insulating piece for temperatures above 130 °C to protect the actuator
- 2) DN 15 to 25 with Type 5757 Actuator:
Use an intermediate insulating piece for temperatures above 110 °C to protect the actuator
- 3) Differential pressure for K_{VS} = 1 and 1.6
- 4) Differential pressure for K_{VS} = 2.5 and 4
- 5) Version with male thread
- 6) Version with female thread

2. Controllers with electric actuators

Type	5757		5724				5725				
	5757-7	5757	-10	-13	-20	-23	-10	-13	-20	-23	
Nominal size	DN	15 to 25	15 to 25	15 to 25	32 to 50	32 to 50	15 to 25	15 to 25	32 to 50	32 to 50	
Scope of application		Heating	DHW heating in instantaneous heating systems, fixed set point control circuits in mechanical engineering								
Safety function		Without			Without		With				
Rated travel	mm	6	6	6	12	12	6	6	12	12	
Transit time for rated travel	s	20	35	18	70	35	35	18	70	35	
Transit time upon fail-safe action	s	-	-				4	4	6	6	
Fail-safe action		-	-				Stem extends				
Nominal thrust	kN	0.3	0.7			0.5					
Manual override		Yes	Yes			Possible ¹⁾					
Power supply		230 V (±10 %), 50 Hz									
Power consumption approx.	VA	3	3	3	7	3	7	5	9	5	9
Permissible temperatures											
Ambient	°C	0 to 50			0 to 50		0 to 50				
Storage	°C	-20 to 70			-20 to 70		-20 to 70				
At connecting rod	°C	0 to 110			0 to 130		0 to 130				
Degree of protection		IP 42			IP 54 (upright position, acc. to DIN IEC 529)						
Inputs and outputs of the digital controller											
Temperature sensor Pt 1000		3 x	1 x	1 x			1 x				
Setting range	°C	1 to 150	0 to 150	1 to 150			1 to 150				
Potentiometer input		1000 to 1100/2000 Ω	-	-			-				
Water flowmeter input		-	530 pulses/l	530 pulses/l			530 pulses/l				
Current input		-	4 (0) to 20 mA	4 (0) to 20 mA			4 (0) to 20 mA				
Binary input BE1 ²⁾		Op. mode switchover	Switching between internal set points/ Deactivation of function to maintain temperature constant								
Binary input BE2 ²⁾		-	Flow switch								
Binary output BA		230 V/50 Hz Cir. pump/External demand	-	-			-				

¹⁾ Manual override using a 4 mm hex screwdriver (after removing the housing cover); always returns to fail-safe position after safety release.

²⁾ Recommendation for Type 5724, Type 5725 and Type 5757: With gold contacts

2 Installation

Caution!

Versions designed to handle temperatures up to 200 °C must be fitted with the dark gray graphite supplied with the valve. Do not use the UDP seals available as accessories as they are only suitable for temperatures up to 150 °C.

2.1 Mounting position

- ▶ Choose the place of installation where the ambient temperature does not exceed or fall below the permissible limits specified for the actuator and that allows you to freely access the control valve even after the entire plant has been completed.
- ▶ Flush the pipeline thoroughly before installation.
- ▶ Do not install the valve with the actuator suspended downwards.
Install versions for water and steam up to 200 °C with the actuator installed upright in a horizontal pipeline.
- ▶ If you wish to insulate the control valve, install an intermediate insulating piece between valve and actuator. Make sure the insulation ends 25 mm above the valve body. Do not insulate the actuator and coupling nut as well.

- ▶ Install a strainer (SAMSON Type 2 NI) upstream of the control valve to prevent any sealing parts, weld spatter or other foreign matter carried along by the process medium from impairing the proper functioning of the valve, in particular, the tight shut-off.
- ▶ The valve must be installed free of stress. If necessary, support the piping near the connections.

2.2 Strainer

- ▶ Install the strainer with the filter element facing downwards upstream of the valve inlet.
- ▶ Choose the place of installation to allow enough space to remove the filter.
- ▶ Install the strainer with the direction of flow as indicated by the arrow on the body.

2.3 Additional installation instructions

We recommend to install a hand-operated shut-off valve both upstream of the strainer and downstream of the control valve to be able to shut down the plant for cleaning and maintenance, and when the plant is not used for longer periods of time.

3 Attaching the actuator to the valve

If the actuator has not already been mounted on the valve by the manufacturer or when the original actuator on a valve is to be replaced with a controller with electric actuator, proceed as follows.

Note!

*Fasten the actuator and valve together either at the valve connection or at the intermediate insulating piece, depending on the valve version, with a tightening torque of **20 Nm**.*

3.1 Type 5757/-7 Controller with Electric Actuator

1. Turn the handwheel (see section 5.1) counterclockwise when the actuator is **disconnected from the power supply** to retract the actuator stem as far as it will go.
2. Place the actuator on the connection piece and secure with the coupling nut.

3.2 Type 5724/5725 Controller with Electric Actuator

Type 5724

1. Turn the handwheel (see section 5.2) counterclockwise to retract the actuator stem as far as it will go.
2. Place the actuator on the connection piece and secure with the coupling nut.

Type 5725 with fail-safe action "Actuator stem extends"

1. Unfasten the front cover and place a 4 mm hex screwdriver on the actuator stem (see section 5.2).
2. Turn the screwdriver **counterclockwise only** and only until the travel final value is reached at the maximum, which activates the bottom torque switch.

Caution!

Turning the actuator too far will destroy it.

3. Hold the screwdriver in place. Secure the actuator and connection piece with the coupling nut.
4. Remove screwdriver and carefully refasten the front cover.

4 Electrical connections



Upon installing the electrical cables, you are required to observe the regulations concerning electrical power installations according to DIN VDE 0100 as well as the regulations of your local power supplier.

Use a suitable power supply to ensure that no dangerous voltages from the system or parts of the system reach the device in standard operation or in case of a fault.

Warning!

Only connect the device to the main power network when the power is switched off. Make sure the power cannot be switched on unintentionally!

- ▶ Perform the electrical wiring as required depending on the application (refer to section 4.1 to 4.3).

As soon as the actuator is connected to the power supply, the initialization procedure starts:

The actuator stem extends and the red and yellow LEDs located under the cover on top of the actuator light up. As soon as the actuator stem has reached the final position, the red LED is turned off. The yellow LED remains illuminated and indicates that the controller with electric actuator is ready for operation.

4.1 Type 5757-7 Controller with Electric Actuator

Heating application: The controller with electric actuator requires a Pt 1000 temperature sensor to be connected to measure the flow temperature. Depending on the control task, an outdoor sensor or a room sensor or a room panel can be connected. Combining one of these sensors with a return flow sensor is usually possible. Additionally, the controller with electric actuator has a potentiometer input 1000 to 1100/2000 Ω . The non-floating pump output can alternatively be used as an binary output for an external request for heat demand.

The default setting (WE) is configured for an application with a flow sensor, outdoor sensor and return flow sensor as well as with an active binary input to switchover the operating modes (see Fig. 2).

4.2 Type 5757 Controller with Electric Actuator

Domestic hot water heating in instantaneous heating system: The controller with electric actuator requires a Pt 1000 temperature sensor to be connected for it to function. Two set points W1 and W2 can be used for control. A binary input BE1 is used to switch between them. In addition, a water flowmeter or a flow switch can be connected to quickly recognize when hot water is being tapped.

The O(4) to 20 mA current input can be used in place of the Pt 1000 sensor for control purposes.

The default setting (WE) is configured for an application with a Pt 1000 flow temperature sensor and water flowmeter (see Fig. 3).

4.3 Type 5724/5725 Controller with Electric Actuator

Domestic hot water heating in instantaneous heating system: The electric wiring options are the same as for the Type 5757 Controller with Electric Actuator, (see section 4.2). In addition, the pump control output can be configured as a fault alarm output.

The default setting (WE) is configured for an application of the electric actuator with a Pt 1000 flow temperature sensor, water flowmeter and pump control output (see Fig. 4).

Note!

Refer to the appendix of these instructions for other possible circuits with the necessary configuration settings or refer to the Mounting and Operating Instructions EB 5757-7 EN, EB 5757 EN and EB 5724 EN of the corresponding controller with electric actuator.

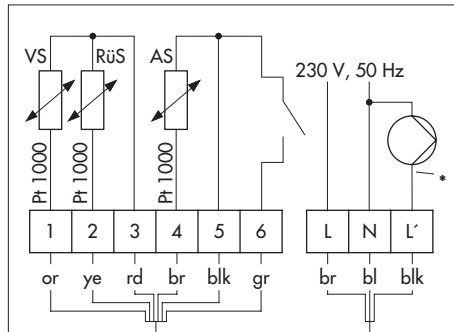

Fig. 2 · Wiring of Type 5757-7 (default)

* **Caution!** Live wires!

- blk black
- bl blue
- br brown
- gr green
- or orange
- rd red
- ye yellow

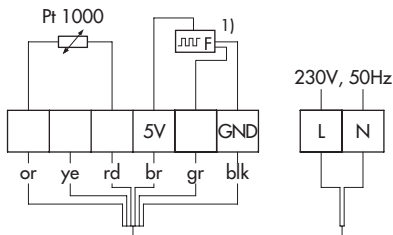

Fig. 3 · Wiring of Type 5757 (default)

- 1) Water flowmeter
- 3) Pump control output or fault alarm output
- 4) Electromagnet, Type 5725 only

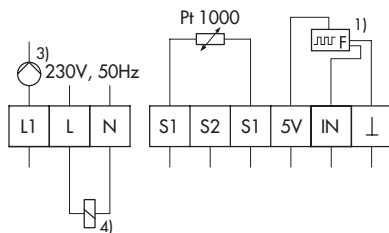

Fig. 4 · Wiring of Type 5724/5725 (default)

5 Manual override

The direction of action and travel can be read off the travel indication scale.

5.1 Type 5757/-7 Controller with Electric Actuator

Caution!

Only activate the handwheel when the actuator is disconnected from the power supply.

- ▶ Turn handwheel clockwise to extend the actuator stem
- ▶ Turn handwheel counterclockwise to retract the actuator stem

5.2 Type 5724/5725 Controller with Electric Actuator

Type 5724

Adjust the travel by turning the handwheel (approx. 4 turns for 1 mm travel):

- ▶ Turn clockwise to extend the actuator stem
- ▶ Turn counterclockwise to retract the actuator stem

Type 5725



Caution!

The actuator is live!

1. Undo the front cover and place a 4 mm hex screwdriver onto the red actuating shaft.
2. Turn the screwdriver **counterclockwise only**, and only until the travel final value is reached at the maximum, which activates the bottom torque switch (switching off the motor).

Caution!

Turning the actuator too far will destroy it.

After the fail-safe action has been triggered by the magnet, the spring mechanism pushes the actuator stem out and the valve always move to its fail-safe position.

3. Remove screwdriver and carefully refasten the front cover.

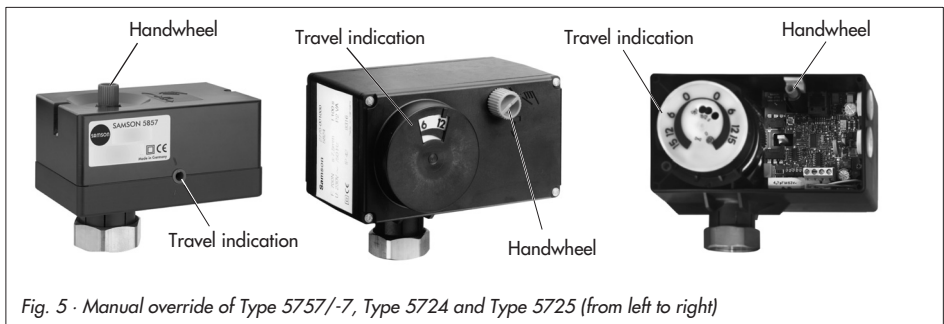

Fig. 5 - Manual override of Type 5757/-7, Type 5724 and Type 5725 (from left to right)

6 Operation

The controllers with electric actuators are adapted to the required control task by configuration and parameterization performed in TROVIS-VIEW Operator Interface:

- ▶ **Type 5757-7:** TROVIS-VIEW 6661-1066
 - ▶ **Type 5757:** TROVIS-VIEW 6661-1062
 - ▶ **Type 5724** and **Type 5725:** TROVIS-VIEW 6661-1060
-

Note!

Instructions on how to operate the TROVIS-VIEW Operator Interface as well as on the function and parameter settings are contained in the Mounting and Operating Instructions EB 5757-7 EN, EB 5757 EN and EB 5724 EN for the corresponding controller with electric actuator.

7 Maintenance

The control valve is subject to natural wear. Depending on the conditions the valve is operated in, it needs to be checked at regular intervals.

If leakage to the atmosphere occurs, remove the valve from the pipeline and replace the damaged parts.



Warning!

For maintenance work on the valve, make sure the relevant section of the pipeline is depressurized and, depending on the process medium, drained as well.

For high medium temperatures, allow the section of the pipeline to cool down before you start.

Make sure the control signal for the actuator is switched off.

8 Dimensions in mm and weights

Nominal size	DN	15	20	25	32	40	50
Thread size	G	½	¾	1	–	–	–
Pipe	Ød	21.3	26.8	33.7	42	48	60
Thread size	R	G ¾	G 1	G 1¼	G 1¾	G 2	G 2½
Width across flats	SW	30	36	46	59	65	82
Length	L	65	70	75	100	110	130
Length with welding ends	L1	210	234	244	268	294	330
Height	H2	45.5			94		
Versions for temperatures up to 200 °C and with intermediate insulating piece		140			185		
Height H3		30			55		
Weight without actuator	approx. kg	1.4	1.8	2.3	4.0	4.4	6.8
Versions for temperatures up to 200 °C and with intermediate insulating piece		1.9	2.3	2.8	4.5	4.9	7.3
Version with threaded ends (male thread)							
Length	L2	129	144	159	180	196	228
Male thread	A	G ½	G ¾	G 1	G 1¼	G 1½	G 2
Weight without actuator	approx. kg	1.4	1.8	2.3	4.0	4.4	6.8
Versions for temperatures up to 200 °C and with intermediate insulating piece		1.9	2.3	2.8	4.5	4.9	7.3
Version with flanges							
Length	L3	130	150	160	180	200	230
Weight without actuator	approx. kg	2.5	3.4	4.1	6.9	7.7	10.7
Versions for temperatures up to 200 °C and with intermediate insulating piece		3.0	3.9	4.6	7.4	8.2	11.2
Version with female thread							
Length	L4	65	75	90	–		
Female thread	G	G ½	G ¾	G 1	–		
Weight without actuator	approx. kg	1.2	1.4	1.5	–		
Versions for temperatures up to 200 °C and with intermediate insulating piece		1.7	1.9	2.0	–		
Version with flanged valve body							
Height	H2	45.5			94		
Length	L3	130	150	160	180	200	230
Weight without actuator	approx. kg	2.5	3.4	4.1	6.9	8.4	11.6
Versions for temperatures up to 200 °C and with intermediate insulating piece		3.0	3.9	4.6	7.4	8.9	12.1

Weights of controllers with electric actuators

Type	5757/-7	5724	5725
Weight without valve, approx. kg	0.7	1.1	1.3

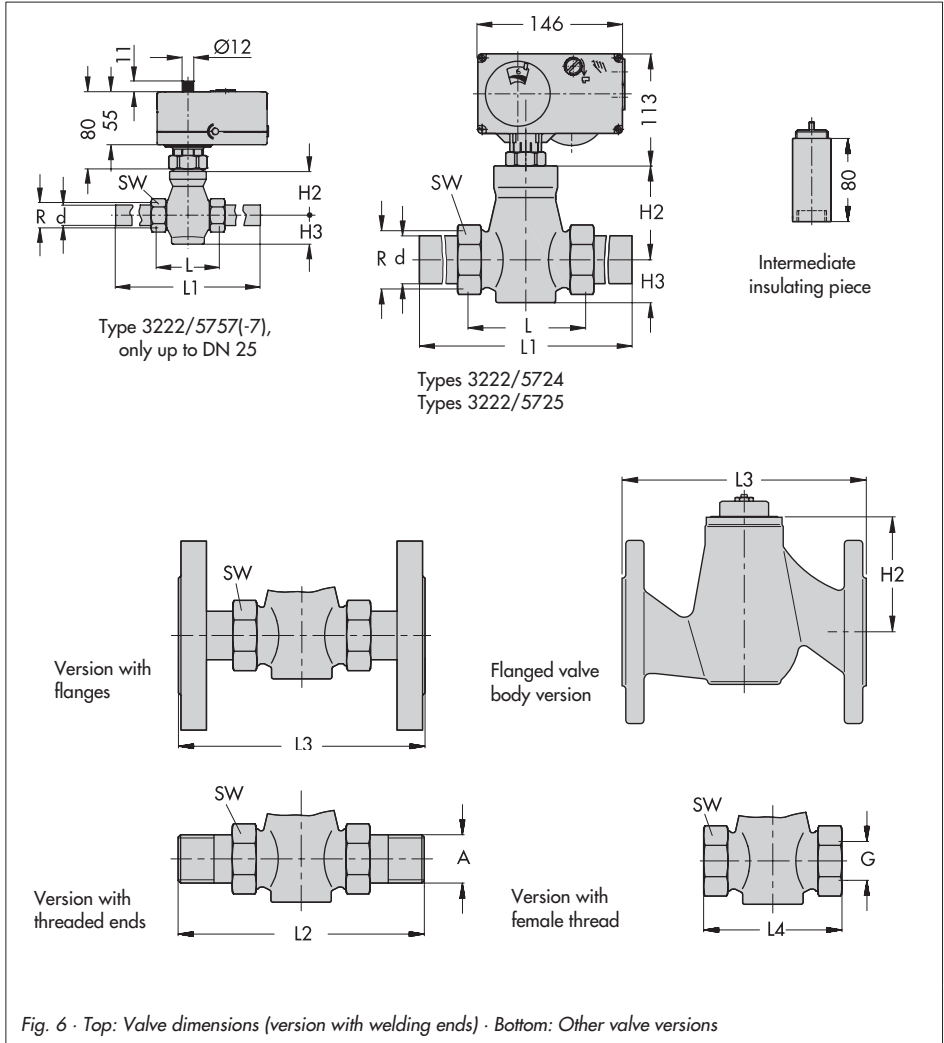

Fig. 6 - Top: Valve dimensions (version with welding ends) · Bottom: Other valve versions

9 Appendix

9.1 Wiring for Type 5757-7 (refer to EB 5757-7 EN)

Note! The pump output L' is non-floating (230 V~).

Note: Terminals at point of installation, not included in scope of delivery

blk black · bl blue · br brown · gr green · or orange · rd red · ye yellow

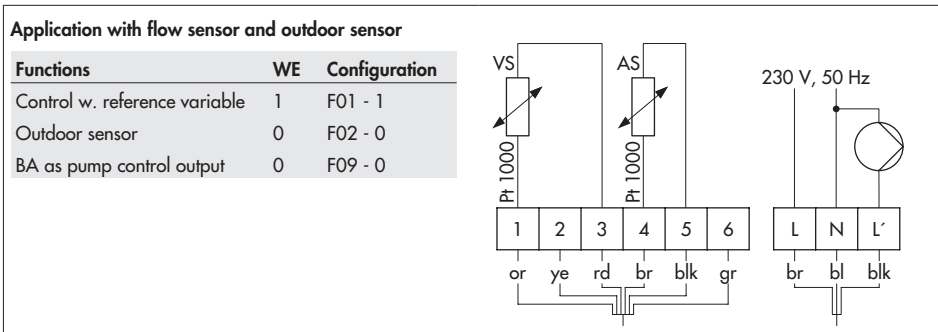
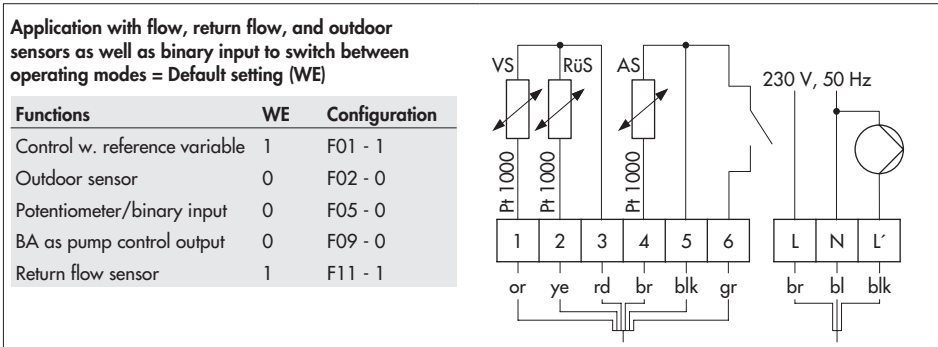
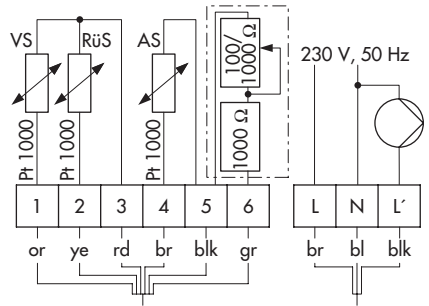

Diagram abbreviations:

VS Flow sensor · RüS Return flow sensor · AS Outdoor sensor

Application with flow, return flow, and outdoor sensors as well as a potentiometer for adjusting the set points

Functions	WE	Configuration
Control w. reference variable	1	F01 - 1
Outdoor sensor	0	F02 - 0
Potentiometer/binary input	0	F05 - 1
Remote adjuster	0	F06 - 1
BA as pump control output	0	F09 - 0
Return flow sensor	1	F11 - 1



Application with flow, return flow, and room sensors with operating mode switchover and set point adjuster

Functions	WE	Configuration
Control w. reference variable	1	F01 - 1
Room sensor	0	F02 - 1
Potentiometer/binary input	0	F05 - 1
Type 5257-7 Room Panel	0	F06 - 0
BA as pump control output	0	F09 - 0
Return flow sensor	1	F11 - 1

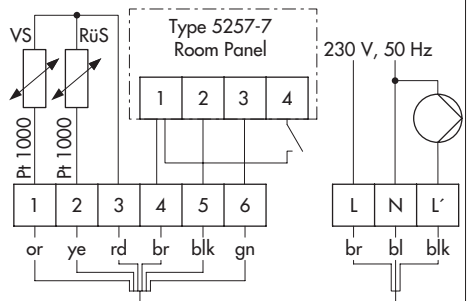

9.2 Wiring for Type 5757 (refer to EB 5757 EN)

Note: Terminals at point of installation, not included in scope of delivery

- 1) Water flowmeter
- 2) Flow switch

blk black · bl blue · br brown · gr green · or orange · rd red · ye yellow

Operation with Pt 1000 sensor and water flowmeter
= Default setting (WE)

Functions	WE	Configuration
Hot water tapping recognition	1	F01 - 1
Water flowmeter	1	F02 - 1
Current input	0	F05 - 0

Operation with Pt 1000 sensor

Functions	WE	Configuration
Hot water tapping recognition	1	F01 - 0
Current input	0	F05 - 0

Operation with Pt 1000 sensor and binary contact for switching between set points

Functions	WE	Configuration
Hot water tapping recognition	1	F01 - 0
Current input	0	F05 - 0
Binary input function	0	F08 - 1

Operation with Pt 1000 sensor and flow switch

Functions	WE	Configuration
Hot water tapping recognition	1	F01 - 1
Flow switch	1	F02 - 0
Current input	0	F05 - 0

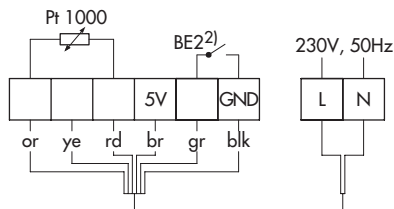

Operation with Pt 1000 sensor and external set point over an mA signal

Functions	WE	Configuration
Hot water tapping recognition	1	F01 - 0
Current input	0	F05 - 0
Current input function	0	F06 - 1

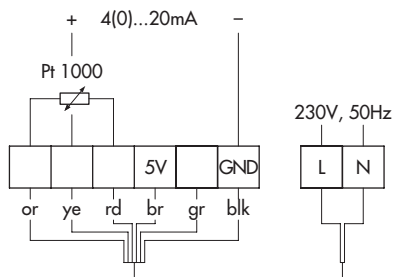

Operation with mA signal input

Functions	WE	Configuration
Hot water tapping recognition	1	F01 - 0
Current input	0	F05 - 0
Current input function	0	F06 - 0

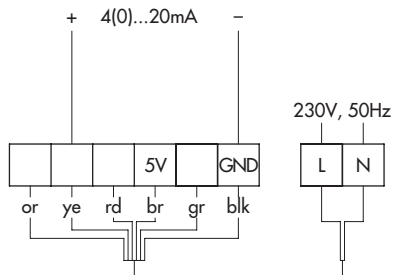

9.3 Wiring for Type 5724/5725 (refer to EB 5724 EN)

- 1) Water flowmeter
- 2) Flow switch
- 3) Pump control output or fault alarm output
- 4) Electromagnet, Type 5725

Domestic hot water heating in instantaneous heating system

Operation with Pt 1000 sensor und water flowmeter
= Default setting (WE)

Functions	WE	Configuration
Hot water tapping recognition	1	F01 - 1
Water flowmeter	1	F02 - 1
Current input	0	F05 - 0

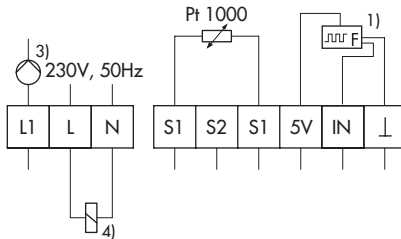

Operation with Pt 1000 sensor

Functions	WE	Configuration
Hot water tapping recognition	1	F01 - 0
Current input	0	F05 - 0

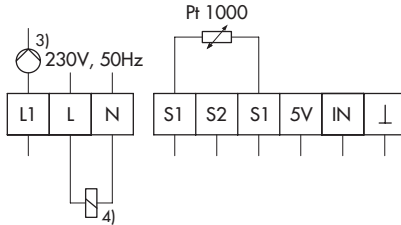

Operation with Pt 1000 sensor and binary contact for switching between set points

Functions	WE	Configuration
Hot water tapping recognition	1	F01 - 0
Current input	0	F05 - 0
Binary input function	0	F08 - 1

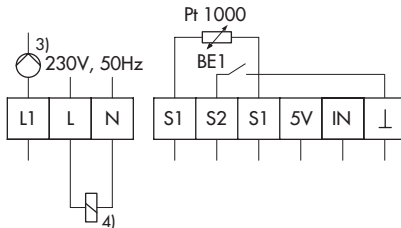

Operation with Pt 1000 sensor and flow switch

Functions	WE	Configuration
Hot water tapping recognition	1	F01 - 1
Flow switch	1	F02 - 0
Current input	0	F05 - 0

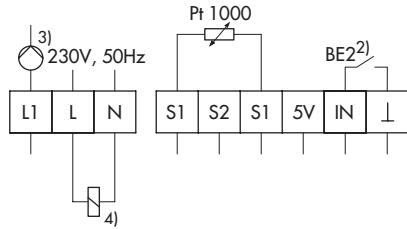

Mechanical engineering applications

Operation with Pt 1000 sensor and external set point over an mA signal input

Functions	WE	Configuration
Hot water tapping recognition	1	F01 - 0
Current input	0	F05 - 0
Current input function	0	F06 - 1

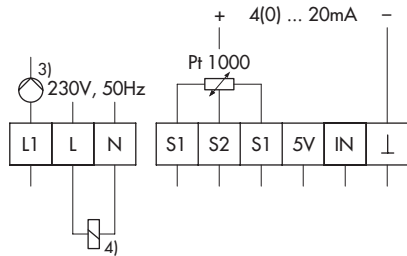

Operation with mA sensor input

Functions	WE	Configuration
Hot water tapping recognition	1	F01 - 0
Current input	0	F05 - 0
Current input function	0	F06 - 0

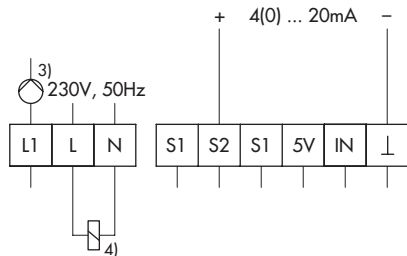



SAMSON AG · MESS- UND REGELTECHNIK
Weismüllerstraße 3 · 60314 Frankfurt am Main · Germany
Phone: +49 69 4009-0 · Fax: +49 69 4009-1507
Internet: <http://www.samson.de>

EB 5766 EN

2008-11

Free Manuals Download Website

<http://myh66.com>

<http://usermanuals.us>

<http://www.somanuals.com>

<http://www.4manuals.cc>

<http://www.manual-lib.com>

<http://www.404manual.com>

<http://www.luxmanual.com>

<http://aubethermostatmanual.com>

Golf course search by state

<http://golfingnear.com>

Email search by domain

<http://emailbydomain.com>

Auto manuals search

<http://auto.somanuals.com>

TV manuals search

<http://tv.somanuals.com>