



Introduction	3
MPL 1204 Features	3
Guided Tour	5
Overview	5
Channels	6
Main Section	8
Rear Panel	11
Connecting The MPL 1204 - General Suggestions	13
Setting Up and Using the MPL 1204	15
Setting the Correct Gain Structure	16
Grounding Techniques	18
Busing, Submixing, and Channel Muting	19
Using Pan	20
Using Equalization	21
Using Aux Sends and Returns	22
Using Inserts	23
PFL/AFL Soloing	24
Applications Notes	25
Using The MPL 1204 As A Recording Mixer	25
Using The MPL 1204 As A Main Live Mixer	26
Using The MPL 1204 As A Keyboard Submixer	27
Linking The MPL 1204 With Other Mixers	28
Appendix A: Block Diagram	29
Specifications	30

---

# Introduction / MPL 1204 Features

Congratulations on purchasing the Samson MPL 1204 four-bus microphone/line mixer! The MPL 1204 is optimized for use in both live performance and recording applications, and it can be used wherever there are a number of microphone or line-level sources that need to be mixed down to two or four outputs. Although the MPL 1204 is designed for easy operation, we suggest you first take some time to go through these pages so you can fully understand how we've implemented a number of unique features.

In this manual, we'll provide you with an overview of MPL 1204 features, followed by a guided tour of its front and rear panels. Then we'll describe how the MPL 1204 should be connected to your existing equipment (including wiring diagrams) and talk about the important topics of gain structure and grounding techniques. Next, we'll cover a number of specific MPL 1204 features (such as busing, submixing, channel muting, as well as using panning, equalization, auxiliary sends and returns, channel inserts, and PFL/AFL) in detail. Finally, we'll wrap things up with a series of applications notes describing a number of ways to use the MPL 1204 for both recording and live performance, plus reference Appendices and full specifications. You'll also find a warranty card enclosed—please don't forget to fill it out and mail it so that you can receive online technical support and so we can send you updated information about other Samson products in the future.

**SPECIAL NOTE:** Should your unit ever require servicing, a *Return Authorization* number (RA) is necessary. Without this number, the unit will not be accepted. Please call Samson at 1-800-372-6766 for a Return Authorization number prior to shipping your unit. Please retain the original packing materials and, if possible, return the unit in its original carton and packing materials.

## MPL 1204 Features

"MPL" stands for "Mic/Program/Line" and the name describes the broad range of signals which can be handled by this powerful four-bus mixer. In fact, the compact design of the MPL 1204 belies an extraordinary versatility. Add excellent sound quality to the equation, and you've got a product which is equally useful in live performance and for recording (you'll find descriptions of each application at the conclusion of this manual). Here are some of the MPL 1204's main features:

- Twelve independent channels, with both mic and line inputs for each channel. This allows you to blend together a variety of source signals, including dynamic or condenser microphones, keyboards, CD/tape players, etc. Standard XLR mic connectors (for microphone inputs) and electronically balanced 1/4" jacks (for line-level inputs) are provided for each channel; in addition, there is a dedicated stereo CD/Tape input that provides dual phono (RCA) jacks.
- Four *bus* outputs (a "bus" is simply a pathway through which a signal can be routed) and an electronically balanced main stereo output, with dedicated front panel control. Any channel input can be routed to either of the two bus pairs (1/2 or 3/4), and any of the buses can be routed to the Left/Right mix output with the touch of a button. This flexible design allows you to easily mute selected channels and/or to create submixes within your main mix.

---

# MPL 1204 Features

- Electronically balanced XLR Main stereo outputs as well as an independent electronically balanced stereo Control Room output (with dedicated level control) for connection to a power amplifier and studio monitors.
- A phantom power switch enables you to use the MPL 1204 with high-quality condenser microphones. When turned on, 48 volts of phantom power is provided to the mic connectors of all twelve input channels.
- Two auxiliary sends and two stereo auxiliary returns (which can be routed to any of the four buses). Aux send 1 is pre-fader and post-equalizer, while Aux send 2 is post-fader and post-equalizer.
- Independent 3-band equalization for each channel, with 15 dB of cut or boost for low (100 Hz) and high (10 kHz) frequencies, and 12 dB of cut or boost for mid (1 kHz) frequencies.
- Constant level Pan controls for each channel that allow you to precisely place each input signal in the left-right plane.
- Center detents for all Pan and EQ controls, making it easy to use the MPL 1204 even in low-light situations such as live performance.
- Selectable *Pre Fade Listen (PFL)* or *After Fade Listen (AFL)* soloing for each channel. PFL allows headphone monitoring of individual channels, pre-fader (but post-EQ), while AFL enables headphone monitoring of individual channels, post-fader and post-EQ. Both types of solo function are non-mix-destructive in that they do not affect the signal being output either by the Main, Bus, or Control Room outputs.
- A flexible front panel metering system includes a ten-segment level meter and allows you to view at a glance the levels of the main Left/Right output, as well as main power, phantom power, and PFL or AFL status.
- An independent front-panel headphone output with dedicated volume control for private monitoring of soloed channels.
- Channel inserts for all twelve channels, enabling you to use outboard signal processors such as equalizers, compressor/ limiters, or noise gates in a standard "effect loop."
- Bus inserts allow external signals to be submixed into any or all of the four buses and also enables linking of multiple mixers.
- The MPL 1204 can be mounted in any standard 19" rack (taking four rack spaces), making it easy to integrate into any existing system.
- Last but certainly not least, affordability. The MPL 1204 has been designed from the ground up to provide versatility and excellent sound quality at a cost-conscious price.

# Guided Tour - Overview

The following illustration shows an overview of the front panel of the MPL 1204:

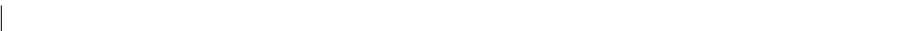
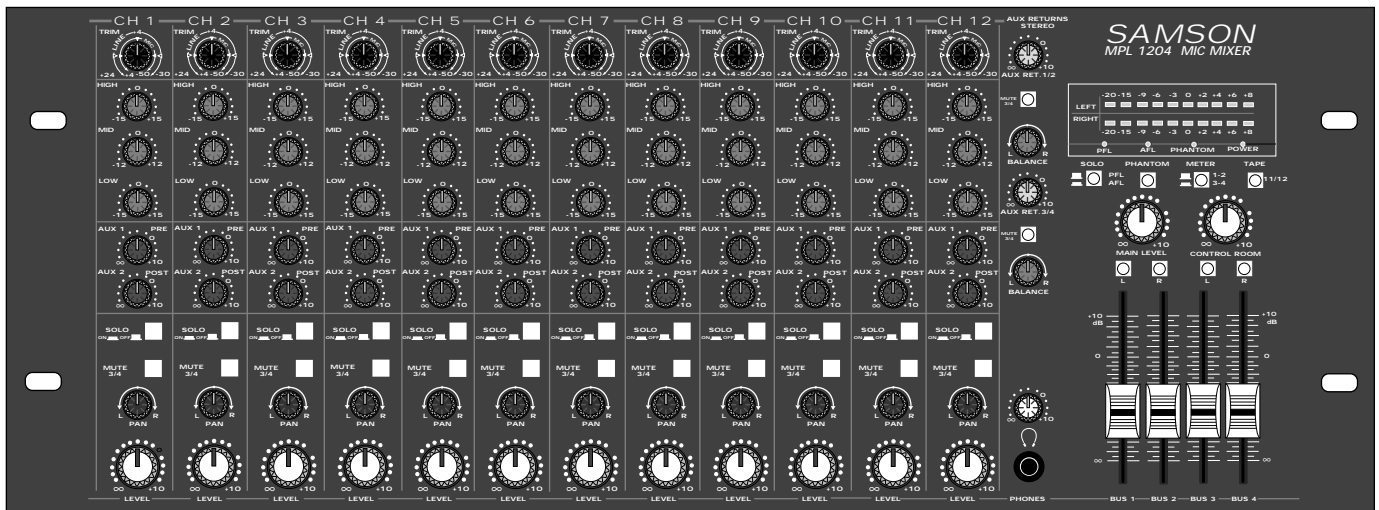

CHANNELS

MAIN SECTION

# Guided Tour - Channels

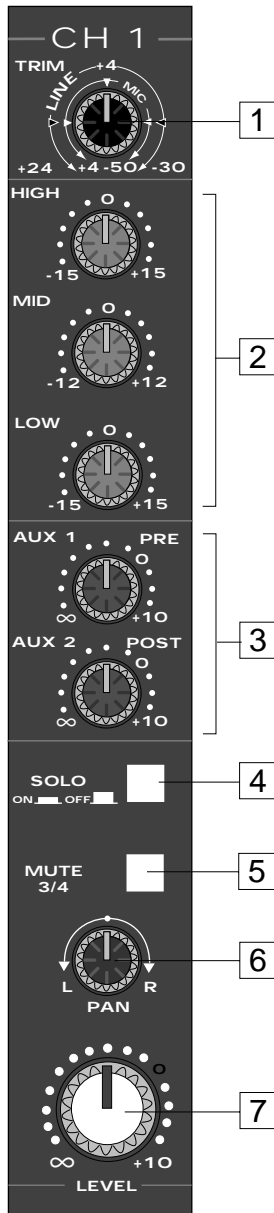

**1: Trim (black)** - This knob determines the input level of the connected signal. Continuously adjustable from +4 dB to -50 dB (for mic inputs) or +24 dB to -30 dB (for line inputs), the input signal is boosted when the trim is turned clockwise and attenuated when turned counterclockwise. For information on how to properly set this for each channel, see the section on page 14 entitled "Setting The Correct Gain Structure."

**2: Equalizer (violet)** - These knobs determine the amount of boost or attenuation in each of three frequency areas (up to 15 dB for low and high frequencies, and up to 12 dB for the mid frequency). The mid frequency control (centered at 1 kHz) utilizes a resonant ("bell") peaking curve, while the high and low frequency controls (centered at 10 kHz and 100 Hz, respectively) utilize shelving curves. A center detent in each knob (at the "0" position) indicates no boost or attenuation (that is, flat response). As each knob is turned clockwise from the "0" position, the frequency area is boosted; as it is turned counterclockwise from the "0" position, the frequency area is attenuated. For more information on the application of EQ, see the "Using Equalization" section on page 19 in this manual.

**3: Auxiliary sends (blue)** - These knobs allow you to route signal to either or both of the MPL 1204's two monophonic Auxiliary outputs. These are typically used to create submixes (for example, a headphone cue mix) and to feed signal from single or multiple channels to outboard effects devices. At the "0" (2 o'clock) position, the signal is routed with unity gain (that is, no boost or attenuation). As each knob is turned clockwise from the "0" position, the signal is boosted; as it is turned counterclockwise from the "0" position, it is attenuated. Aux send 1 is post-eq but *pre-fade*; that is, the level of the signal is determined solely by its Trim control and its EQ settings (see #1 and #2 above). In contrast, Aux send 2 is post-eq and *post-fade*; that is, the level of the signal is determined by the channel's Trim control, its EQ settings, and the position of its Level control. For more information, see the "Using Aux Sends and Returns" section on page 20 in this manual.

**4: Solo On/Off switch** - When pressed in, the channel is soloed (in headphones only). Soloing will be in either PFL (Pre Fade Listen) or AFL (After Fade Listen) mode, depending upon the setting of the PFL/AFL switch in the MPL 1204 main section. See #7 and #8 on page 7 and the "PFL/AFL Soloing" section on page 22 in this manual for more information.

**5: Mute 3/4 switch** - When up, the channel's signal is routed to the Bus 1/2 faders and then on to the Bus 1/2 and, optionally, Main and Control Room output jacks (if, as described in #14 on page 8, the Bus "L/R" switches for those buses is pressed in). When pressed in, the channel's signal is instead routed to the Bus 3/4 faders and then on to the Bus 3/4 and, optionally, Main and Control Room output jacks (if, as described in #14 on page 8, the Bus "L/R" switches for those buses is pressed in). If you set the Bus 3/4 faders all the way down (to their "∞" position), this switch can be used for channel muting. See the "Busing, Submixing and Channel Muting" section on page 17 in this manual for more information.

**6: Pan (green)** - This knob allows you to place the input signal anywhere in the left-right stereo spectrum, while keeping the overall signal level constant. When the knob is placed at its center (detented) position, the signal is sent equally to both left and right outputs of the selected bus (depending upon the setting of the channel's Mute 3/4 switch, as described in #5 above). When moved left of center, less signal is sent to the right output and more signal is sent to the left output (making the sound appear left of center) and when moved right of center, less signal is sent to the left output and more signal is sent to the right output (making the sound appear right of center). To route a signal hard left or right, place the pan knob either fully counterclockwise or fully clockwise. For more information, see the "Using Pan" section on page 18 in this manual.

**7: Level** (white) - This knob (purposely made a little bigger than the others so you can find it easily in low-light situations) controls the volume of the channel input. In practice, you will use the Level controls to continuously adjust the loudnesses of the various signals being blended together by the MPL 1204. The "0" (2 o'clock) position of the knob indicates unity gain (no level attenuation or boost). Moving the knob counterclockwise from the "0" position (towards " $\infty$ ") causes the signal to be attenuated (at the very bottom, it is attenuated infinitely—in other words, there is no sound). Moving it clockwise from the "0" position (towards "+10") causes the signal to be boosted by as much as 10 dB.

For best signal-to-noise ratio, all Level controls for channels carrying signal should generally be kept at or near the "0" position. Channels that are unused should have their Level controls kept fully counterclockwise at their " $\infty$ " (minimum) level. See the "Setting the Correct Gain Structure" section on page 14 in this manual for more information.

# Guided Tour - Main Section

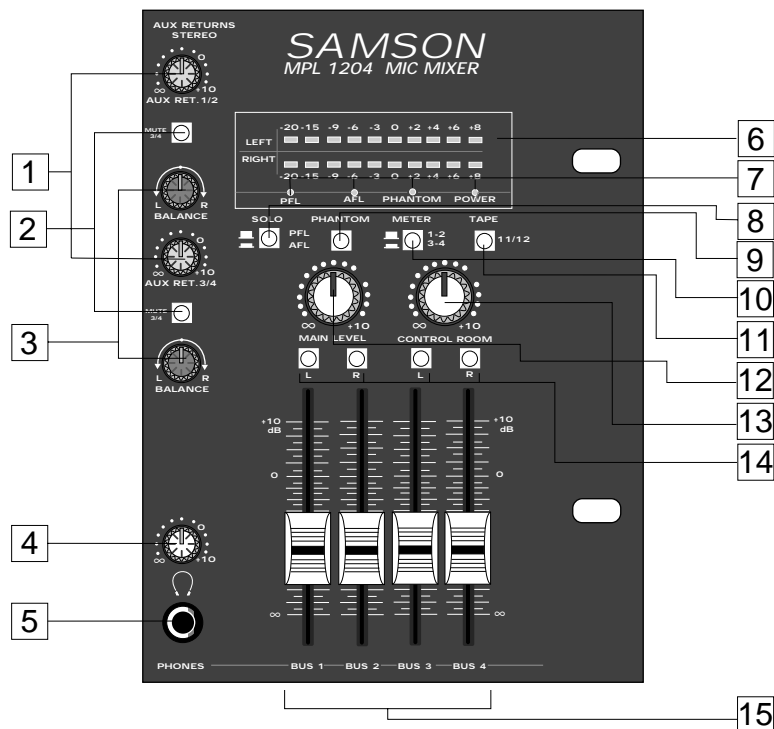

**1: Auxiliary Return Level (orange)** - These knobs determine the input level of signal arriving via the MPL 1204's two stereo Auxiliary returns. The "0" (2 o'clock) position of each knob indicates unity gain (no level attenuation or boost). Moving each knob counterclockwise from the "0" position (towards "∞") causes the signal to be attenuated (at the fully counterclockwise position, it is attenuated infinitely—in other words, there is no sound). Moving each knob clockwise from the "0" position (towards "+10") causes the signal to be boosted by as much as 10 dB. For information on how to properly set these, see the sections in this manual entitled "Setting the Correct Gain Structure" and "Using the Aux Sends and Returns" (pages 14 and 20).

**2: Stereo Auxiliary Return Bus switch** - These switches determine which of the two pairs of stereo buses (1/2 or 3/4) the Aux return signal is routed to. When up, the Return's signal is routed to the Bus 1/2 faders and then on to the Bus 1/2 jacks as well as (if the Bus "L/R" switch is pressed in—see #14 on page 8) the Main and Control Room output jacks. When pressed in, the channel's signal is instead routed to the Bus 3/4 faders and then on to the Bus 3/4 jacks as well as (if the Bus "L/R" switch is pressed in) the Main and Control Room output jacks. If you set the Bus 3/4 faders all the way down (to their "∞" position), this switch can be used for selective muting of Aux returns. For more information, see the sections in this manual entitled "Busing, Submixing and Channel Muting" and "Using the Aux Sends and Returns" (pages 17 and 20).



**3: Stereo Auxiliary Return Balance** (brown) - These knobs determine the relative levels of the left and right input signals connected to the MPL 1204's two stereo Auxiliary returns. When the knob is placed at its center (detented) position, both left and right input signals for that Aux return are at equal strength. When moved left of center, the left input signal remains at the same strength but the right input signal is attenuated; when the knob is moved right of center, the right input signal remains at the same strength but the left input signal is attenuated. When placed fully counterclockwise, only the left input signal is heard (panned hard left); when placed fully clockwise, only the right input signal is heard (panned hard right). These "radical" positions are useful when you are using a stereo Aux return as two mono returns—see the "Using Aux Sends and Returns" section on page 20 in this manual for more information.

**4: Headphone Level** - This knob sets the level of the signal sent to the headphone jack (see #5 below). **WARNING:** To avoid possible damage to connected headphones (or, worse yet, to your ears!), always turn this all the way off (to the fully counterclockwise "0" position) before plugging in a pair of headphones—then raise the level *slowly* while listening. The Headphone Level has no effect on the final Main output level or on the Control Room output level.

**5: Headphone jack** - Connect any standard stereo headphones to this jack (via a 1/4" TRS plug) for private monitoring of all soloed channels. The built-in MPL 1204 headphone preamp delivers 120 mw at 33 ohms. For more information, see the "PFL/AFL Soloing" section on page 22 in this manual.

**6: Meter** - This ten-segment bar meter shows the continuous output level of either Bus 1/2 or Bus 3/4, depending upon the setting of the Meter switch (see # 10 on page 8). For optimum signal-to-noise ratio, try to adjust all channel levels so that program material is usually at or around 0 VU, with occasional but not steady excursions to the red "+" segments. See the "Setting the Correct Gain Structure" section on page 14 in this manual for more information.

**7: Status LEDs** - These show the status of various conditions within the MPL 1204. The leftmost LED (labeled "PFL") lights steadily green when the MPL 1204 is in PFL mode (see #8 below). The left center LED (labeled "AFL") lights steadily red when the MPL 1204 is in AFL mode (see #8 below). The right center LED lights steadily green when the Phantom Power switch (see #9 below) is engaged and 48 volts phantom power is being delivered to all XLR mic connectors. The rightmost LED (labeled "Power") lights steadily red whenever the MPL 1204 is powered on.

**8: Solo switch** - This determines whether the MPL 1204 is in PFL mode (switch up) or AFL mode (switch pressed in). For more information, see the "PFL/AFL Soloing" section on page 22 in this manual.

**9: Phantom Power switch** - When this switch is pressed in, the MPL 1204 delivers 48 volts of phantom power to pins 2 and 3 of all XLR microphone connectors in all twelve channels. **WARNING:** Only use this switch with the MPL 1204 powered down. Before turning phantom power on, be sure to disconnect all non-microphone signal sources (such as passive direct injection boxes) from the XLR mic jacks. Although phantom power will have no adverse affect on connected dynamic microphones, it should be used only when one or more condenser microphones are connected to the MPL 1204. **Refer to the owners manual of your microphone to determine whether or not it requires 48 volts phantom power—we cannot assume responsibility if you damage a mic by incorrectly applying phantom power.** If you're not completely

---

# Guided Tour - Main Section

certain that one or more connected mics require 48 volts phantom power, leave this switch off (its out position).

**10: Meter switch** - When out, the ten-segment MPL 1204 meter (see #6 on the previous page) shows the continuous output level of Bus 1-2; when pressed in, the meter shows the continuous output level of Bus 3-4.

**11: Tape switch** - Press this in to route signal connected to the rear panel RCA jack tape inputs to channels 11 and 12 (the left side is routed to channel 11 and the right side is routed to channel 12). When this switch is pressed in, any mic or line input signal connected to channels 11 and 12 is automatically muted.

**12: Main Level** - This knob determines the final signal level of the rear panel Main output—you can think of it as being the “master fader.” The 2 o’clock “0” position of the knob indicates unity gain (no level attenuation or boost). Moving the knob counterclockwise from the “0” position (towards “∞”) causes the signal to be attenuated (at the very bottom, it is attenuated infinitely—in other words, there is no sound). Moving it clockwise from the “0” position (towards “+10”) causes the signal to be boosted by up to 10 dB. For more information, see the “Setting The Correct Gain Structure” section on page 14 in this manual.

**13: Control Room Level** - This knob determines the signal level of the rear panel Control Room output, allowing independent monitoring of the Main output signal. The 2 o’clock “0” position of the knob indicates unity gain (no level attenuation or boost). Moving the knob counterclockwise from the “0” position (towards “∞”) causes the signal to be attenuated (at the very bottom, it is attenuated infinitely—in other words, there is no sound). Moving it clockwise from the “0” position (towards “+10”) causes the signal to be boosted by up to 10 dB.

**14: Bus L/R switches** - These switches allow you to route the output from the four buses to the Main left/right output jacks and Control Room left/right output jacks on the rear panel (see #10 and #11 on page 10). When this switch is up, the signal from that bus is not routed to the main outputs and instead terminates at its Bus out jack (see #12 on page 10). When pressed in, the signal from that bus is routed to the Main and Control Room outputs (buses 1 and 3 are routed to the left Main and Control Room output jacks and buses 2 and 4 are routed to the right Main and Control Room output jacks) as well as to its Bus out jack. For more information, see the “Busing, Submixing and Channel Muting” section on page 17 in this manual.

**15: Bus Faders** (white with blue line) - These linear sliders determine the relative level of the four bus outputs. The “0” position of each fader indicates unity gain (no level boost or attenuation). Moving the fader below this position (towards the “∞” position) causes the signal to be attenuated (at the very bottom, it is attenuated infinitely—in other words, there is no sound). Moving it above this position (towards the “+10 dB” position) causes the signal to be boosted by up to 10 dB. For best signal-to-noise ratio, all Bus faders should generally be kept at or near the 0 level. For more information, see the “Setting The Correct Gain Structure” and the “Busing, Submixing and Channel Muting” sections on pages 14 and 17 in this manual.

# Guided Tour - Rear Panel

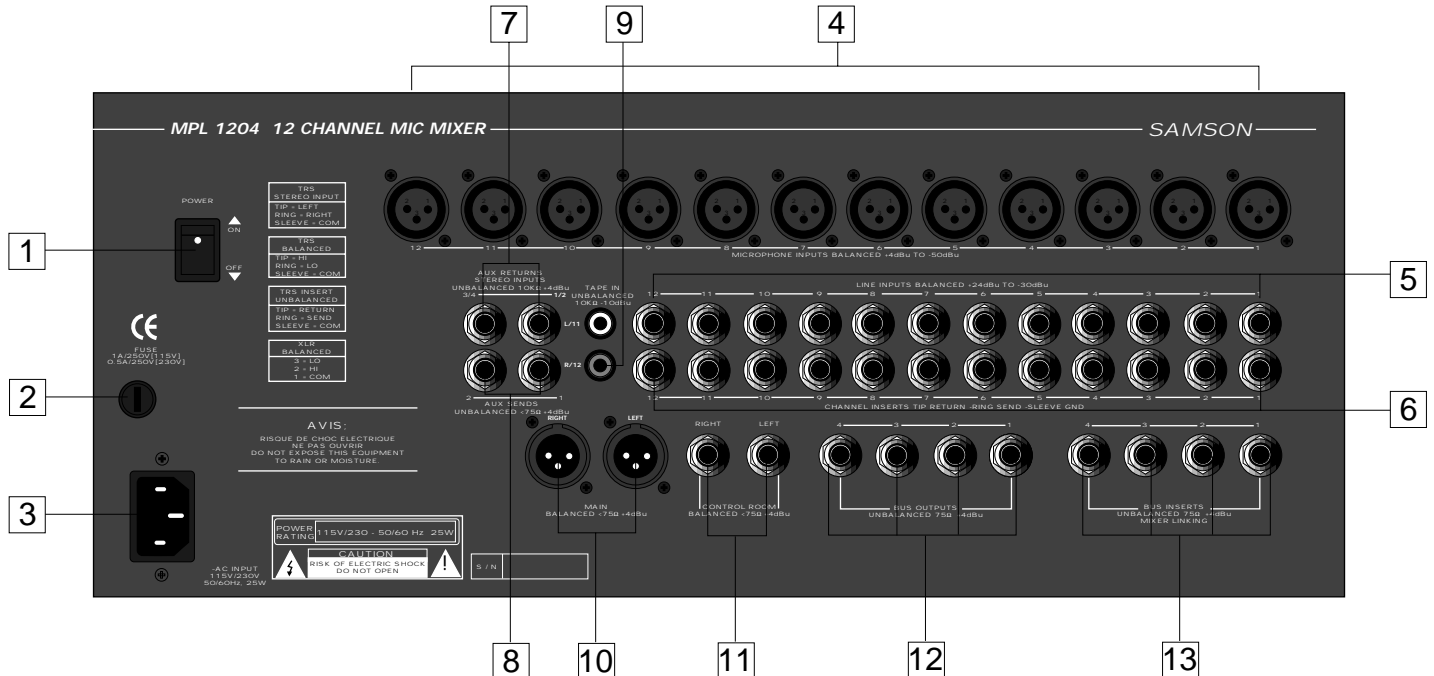

**1: Power on-off switch** - As you may have guessed, this is what you use to turn the MPL 1204 on and off. To avoid potential damage to your speakers, turn the MPL 1204 on *before* you turn on any connected power amps—and turn it off *after* the power amps are turned off.

**2: Fuse** - Contains a 1 amp, 250 volt fuse for 115 volt operation or a 0.5 amp, 250 volt fuse for 230 volt operation.

**3: AC input** - Connect the supplied standard 3-pin “IEC” plug here.

**4: Mic inputs (1 - 12)** - Use these electronically balanced XLR jacks to connect microphones to the MPL 1204. These are intended to accept signal from low-level, low-impedance mics but can also be used for signal from other sources (such as direct injection boxes) if the channel’s Trim control (see #1 on page 4) is turned down.

**WARNING:** Do not connect a channel’s microphone input if you already have something connected to its line input (see #5 below); all channels are designed to accept only one source or the other.

**5: Line inputs (1 - 12)** - Use these electronically balanced 1/4" jacks to connect line-level sources such as synthesizers, drum machines, CD players, tape decks, or effects processors to any of the MPL 1204’s twelve channels. Use balanced three-conductor cabling and Tip/Ring/Sleeve (TRS) plugs wherever possible (unbalanced two-conductor plugs can also be inserted into these inputs, but you’ll get better signal quality and less outside noise and hum if you use balanced lines). The “Connecting the MPL 1204” section on page 11 in this manual provides more information on how best to use channel inputs. **WARNING:** Do not connect a channel’s line input if you already have something connected to its microphone input (see #4 above); all channels are designed to accept only one source or the other.

**6: Channel Inserts (1 - 12)** - Use these to insert an external effects processor (such as outboard equalizer, compressor/limiter or noise gate) into any of the MPL 1204’s channels in an “effects loop” configuration. These jacks accept 1/4" TRS plugs, with the ring carrying the send signal and the tip carrying the return signal. Normally, this will be connected to a Y-cord; see the “Connecting The MPL 1204” section on page 12 in this manual for more information and a wiring diagram.

---

# Guided Tour - Rear Panel

**7: Aux Returns (1/2, 3/4)** - These unbalanced 1/4" TRS inputs allow you to route signal from external devices such as effects processors to either of the two stereo Aux Returns. These jacks accept 1/4" TRS plugs, with the tip carrying the left signal and the ring carrying the right signal (sleeve is common ground). See the "Using Aux Sends and Returns" section on page 20 in this manual for more information.

**8: Aux Sends (1, 2)** - These unbalanced 1/4" outputs allow you to route signal from either of the two discrete Aux Sends to external devices such as effects processors. All four MPL 1204 Aux sends are post-fade. See the "Using Aux Sends and Returns" section on page 20 in this manual for more information.

**9: Tape/CD inputs (L, R)** - Use this set of dual RCA jacks to connect the outputs of a tape or CD player to the MPL 1204. When the "Tape" switch (see #11 on page 8) is pressed in, signal connected here is routed to channels 11 and 12 (the left side is routed to channel 11 and the right side is routed to channel 12), with any mic and line input signal connected to channels 11 and 12 automatically muted.

**10: Main outputs (L, R)** - These are the MPL 1204's main outputs. In live performance applications, you'll usually use these to connect the MPL 1204 to a power amp and speakers; in recording applications, these will normally be connected to the inputs of a two-track recorder. The Main out XLR jacks are electronically balanced, so you should use balanced three-conductor cabling wherever possible for optimum signal quality and reduced outside noise and hum. See the "Connecting the MPL 1204" section on page 11 in this manual for more information.

**11: Control Room outputs (L, R)** - In recording applications, these will normally be connected to a power amplifier and loudspeakers. The Control Room out jacks are electronically balanced, so you should use balanced three-conductor cabling and 1/4" TRS plugs wherever possible (unbalanced two-conductor plugs can also be inserted into these outputs, but you'll get better signal quality and less outside noise and hum if you use balanced lines). See the "Connecting the MPL 1204" section on page 11 in this manual for more information.

**12: Bus outputs (1 - 4)** - These unbalanced outputs allow you to route signal from each of the four discrete buses to external devices such as a multitrack digital or analog tape recorder. The signal is post-bus fader but pre-Main control. See the "Busing, Submixing, and Channel Muting" section on page 17 in this manual for more information.

**13: Bus Inserts (1 - 4)** - Use these to insert an external effects processor (such as outboard equalizer, compressor/limiter or noise gate) into any of the MPL 1204's four buses in an "effects loop" configuration. This enables you to process a group of signals simultaneously (such as a drum submix being sent to a single track of a tape recorder) at unity gain. These jacks accept 1/4" TRS plugs, with the ring carrying the send signal and the tip carrying the return signal. Normally, this will be connected to a Y-cord; see the "Connecting The MPL 1204" section on page 12 in this manual for more information and a wiring diagram. Bus inserts can also be used to link multiple MPL 1204s or to bring the output from another mixer into the MPL 1204 without taking up channel line inputs. See the "Using Inserts" section on page 21 and the "Linking the MPL 1204" Application on page 26 in this manual for more information.

# Connecting The MPL 1204 - General Suggestions

The actual connections you'll make to and from the MPL 1204 will vary according to the environment you use it in and the particular equipment you have. In the "MPL 1204 Applications" sections at the rear of this manual, you'll find some suggested setups. Here are a few basic rules concerning MPL 1204 connections that will apply in most situations:

- In general, it's best to make all connections with the MPL 1204 and any connected power amplifiers turned off. If you must make connections with the power on, make sure that the Main and Control Room Level knobs are completely counterclockwise and that all four bus faders are completely down (at their "∞" position). Whenever powering down, bring the Main and Control Room Level knobs completely counterclockwise and set all four bus faders completely down, turning off the main power amps *first*. Wait a few seconds for their power supplies to discharge and then turn off all connected equipment, turning the MPL 1204 off *last*.
- Try to use balanced connectors and cabling wherever possible. These kind of connections do a better job of rejecting extraneous noise and hum and generally provide a cleaner signal. Although the MPL 1204 will accept unbalanced connectors throughout, it specifically provides electronically balanced inputs for all mic and line inputs and for its Main and Control Room outputs. The wiring diagram below shows how 1/4" TRS (Tip/Ring/Sleeve) connectors should be wired for use with line-level inputs and Control Room outputs:

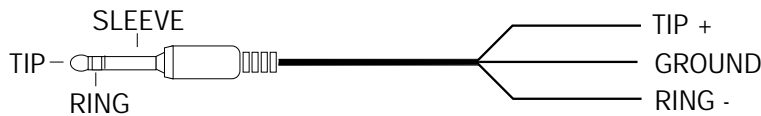

XLR connectors for mic-level inputs and the Main outputs should be wired as follows:

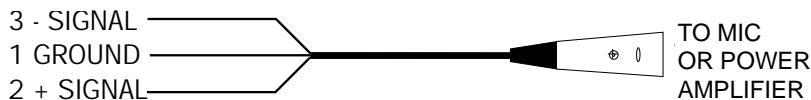

Unbalanced cables use standard 1/4" phone connectors, wired as follows:

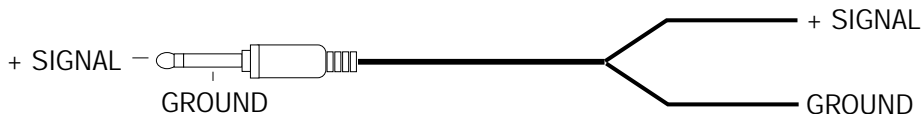

- Make one connection at a time and then monitor the incoming signal. If you hear a distinct hum or buzz, you may have a grounding problem with that particular device. See the "Grounding Techniques" section on page 16 in this manual for information on how to avoid grounding problems.

---

# Connecting The MPL 1204 - General Suggestions

- NEVER connect a microphone and line level input to the same channel simultaneously—use one or the other. You can have some channels connected to microphones and others to line level signals (for example, you might want to plug mics into channels 1 - 4 and line level signals into the remaining channels)—just don't have both kinds of inputs connected to the *same* channel.
- There are two “hidden” (or at least not so obvious) stereo inputs to the MPL 1204; these are the Auxiliary returns. Use these whenever you want to bring in stereo signals that will not need to be equalized.
- Channel and bus insert cables (sometimes called “Y-cords”) should terminate in standard 1/4" TRS jacks (ring to send and tip to return), wired as follows:

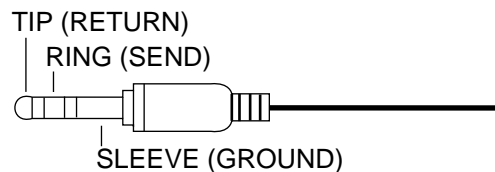

- The MPL 1204 Aux return jacks are unbalanced stereo inputs, with the tip carrying the left input signal and the ring carrying the right input signal (with the sleeve carrying common ground), as shown below. Insertion of a monophonic 1/4" jack into an Aux return will result in the incoming signal being automatically routed to the left input only (and therefore panned hard left).

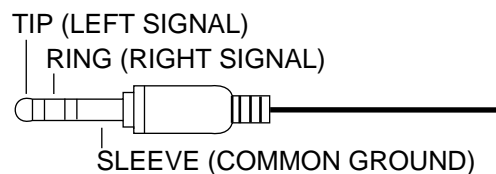

# Setting Up and Using The MPL 1204

Setting up your MPL 1204 is a simple procedure which takes only a few minutes:

1. Remove all packing materials (save them in case of need for future service) and decide where the unit is to be physically placed—it can be mounted in any standard 19" rack, requiring four rack spaces, or used on a tabletop.

2. Before even plugging the unit into an AC socket, begin by connecting the MPL 1204 Main or Control Room outputs into a power amp and the amp into loudspeakers (you'll usually connect the Main output to a power amp in live performance environments and the Control Room output to a power amp when using the MPL 1204 for recording). It is never a good idea to power up any amplifier that is not connected to loudspeakers.

3. Next, make the signal input connections to the mic or line inputs of the various channels. **WARNING:** Do not connect a channel's line input if you already have something connected to its microphone input, or vice versa; each channel is designed to accept only one source or the other.

4. Set all channel Trim controls fully counterclockwise (to their "+4" setting) and turn all channel Level controls fully counterclockwise (to their "∞" setting). Then bring all four bus faders completely down (to their "∞" setting), and set the Main and Control Room Level controls fully counterclockwise (to their "∞" setting). Finally, connect the IEC main power cord and plug the MPL 1204 into any grounded AC socket.

5. Turn on the rear panel Power switch—the "Power" LED in the main section will light up.

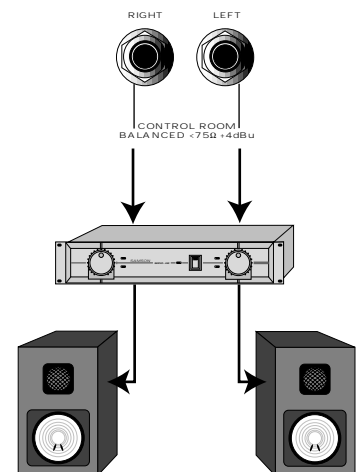
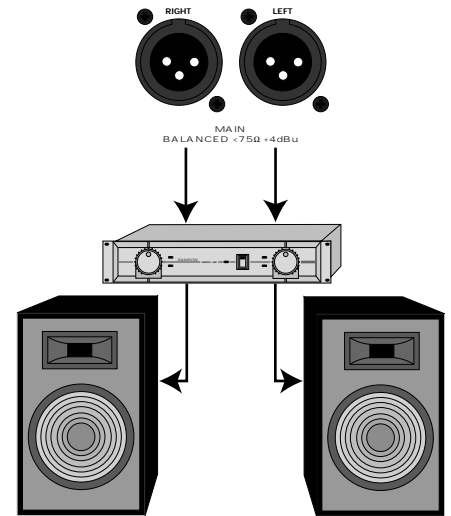

---

# Setting the Correct Gain Structure

You're now ready to establish the correct gain structure—the key to getting the best performance from the MPL 1204, or from any mixer, for that matter. This is a simple procedure that ensures optimum input and output levels so that no unnecessary noise (caused by too low a signal) or overload distortion (caused by too high a signal) is created. Here's a step-by-step description of how to do so:

- a. With all connections made (as described above) but with *the power amplifier and MPL 1204 off*, start by setting the power amplifier volume to minimum. On the MPL 1204, set all channel Trim knobs to their fully counterclockwise (+4) position and turn all channel Level controls fully counterclockwise (to their "∞" position). Set all channel EQ and Pan knobs to their center detent "0" positions.
- b. Make sure the Mute switch for all channels is set to the out (unmuted) position check that the Meter 1-2 / 3-4 switch (in the main section) is set to its out (1-2) position. This ensures that all channels are routing signal solely to buses 1 and 2 and that the meter will display the bus 1-2 output.
- c. If the Main output jacks are connected to a power amplifier and loudspeakers (as described in #2 on page 13), set the Main Level knob to its 2 o'clock "0" position. If the Control Room output jacks are connected to a power amplifier and loudspeakers (as described in #2 on page 13), set the Control Room Level knob to its 2 o'clock "0" position.
- d. Set all channel Aux send knobs and both Aux return Level knobs to their fully counterclockwise ("∞") position. Set both Aux return Balance knobs to their center detent "0" positions.
- e. Turn on all devices connected to channel line inputs and Aux returns and set their output level controls to unity gain or, if there is no unity gain indicated on their output control, to maximum. If you've got outboard effects processors connected to Aux returns, make sure they are sending completely "wet" (processed) signal, with no "dry" (unprocessed) signal mixed in. If condenser microphones are connected to the MPL 1204, turn on the Phantom switch.\*
- f. Set the bus 1 and bus 2 faders at their "0" (unity gain) position and turn on the MPL 1204's rear-panel Power switch—the Power LED in the main section will light up. Finally, turn on your power amplifier.
- g. Play an instrument connected to one of the MPL 1204's line inputs\*\* and, while doing so, slowly raise the corresponding channel Level control to the 2 o'clock "0" position. You should see the MPL 1204 meters begin to move. While watching the meters, adjust the Trim control for that channel so that the "0" segment lights frequently, with only occasional excursions into the "+" segments. If the signal seems too hot even with the input channel trim all the way at its minimum (+4) setting, you may need to lower the output level of the instrument, though this will rarely occur. Conversely, if the signal is too low even with the input channel trim all the way up, something's definitely wrong: in all likelihood, the connecting audio cable is faulty.

\* *CAUTION: Before turning phantom power on, be sure to verify that all connected mic(s) and/or active DI boxes require 48 volts. Also, disconnect all other signal sources (such as passive DI boxes) from the XLR mic jacks.*

\*\* *If you're using an instrument such as electric guitar or bass, we recommend that you connect it to the MPL 1204 with a direct injection box to ensure correct impedance.*



---

# Setting the Correct Gain Structure

h. Once you've set the optimum level in step (g) above, continue playing the instrument and slowly raise the level of your power amplifier until you reach the desired listening level. Repeat step (g) above for each instrument connected to the MPL 1204 channel line inputs.

i. The procedure for setting optimum microphone levels is virtually identical; sing or speak into each mic at the level you expect to use in performance while slowly raising the Level control for that channel to its "0" position. Then adjust the Trim control for that channel while watching the segment meter. You should expect that mic-level inputs will require rather more in the way of Trim boost than line-level inputs.

j. If you have any outboard signal processors connected to the Aux send and return jacks on the rear panel, follow this step. Because outboard effects processors can sometimes be quite noisy, it's particularly important to maximize the amount of signal being sent to them via the MPL 1204 Aux sends. The idea is to drive these devices as hot as possible (short of overloading them) and then to use the corresponding Aux return level to carefully adjust the amount of processed signal being blended with the dry signal. To set optimum Aux send levels, use a channel that has already had its gain structure adjusted in step (g) or (i) above. Turn both Aux send knobs for that channel to their "0" (unity gain) position. Then play the instrument (or sing into the microphone) connected to that channel. Adjust the input levels of connected outboard effects processors so that their meter shows incoming signal normally in the 0 vu range (with only occasional higher excursions). Finally, optimize the Aux return levels: While continuing to play your instrument (or continuing to sing into the microphone), slowly raise each Aux return level control until you hear the desired amount of processed signal added to the dry signal. Adjust the Aux return Balance controls as required in order to set the relative levels of the signal arriving at the left and right Aux return inputs. For more information, see the "Using Aux Sends and Returns" section on page x in this manual.

k. At this point, if you want to route any channel or Aux return signal(s) to any of the four bus outputs at optimum level, simply set the channel's "Mute 3/4" or Aux return's Bus switch correctly and raise the corresponding bus fader to its "0" (unity gain) position.

l. The gain structure is now correctly set—you've optimized the level of all signals coming into and out of the MPL 1204, and the end result will be minimum noise and distortion and maximum clean sound. You'll now find that the majority of your mixes can be accomplished with the Main or Control Room Level knobs and with most channel Level controls at or near their 2 o'clock "0" (unity gain) position. If you need to make adjustments to the overall level, use the level control of your power amplifier.

If you encounter difficulty with any aspect of setting up or using your MPL 1204, you can call Samson Technical Support (1-800-372-6766) between 9 AM and 5 PM EST.

---

# Grounding Techniques

Hum and buzz are the biggest enemies you face when interconnecting a large number of different pieces of equipment to a central audio mixer. This is because each piece of equipment may operate at a marginally different voltage (this difference is called *potential*) and, when two devices at slightly different potential are physically connected with audio cabling, the end result can be nasty, extraneous noise (mind you, connecting two devices at very different potential can result in a major electrical shock!).

However, there are several steps you can take to avoid grounding problems. First, assuming you have an isolated electrical circuit that can handle the electrical demands of your mixer and all connected audio equipment (these needs will usually be modest), you should always plug your mixer and all connected equipment into the same circuit. If possible, nothing else but this equipment should be connected to that circuit. If you can't do this, at least avoid plugging your mixer and audio equipment into the same circuit that is already powering things like heavy machinery, air conditioners, heaters, refrigerators, washing machines, neon signs or fluorescent light fixtures. One particular culprit that will almost certainly create problems is the standard light dimmer (the kind that uses silicon controlled rectifiers). Where low-level lighting is desired, use incandescent fixtures with autotransformer-type dimmers (sometimes called *Variacs*) instead—these cost considerably more than the standard dimmer you'll find at your local hardware store, but are well worth the extra expense.

Three-prong plugs (such as the one used by the MPL 1204) should always be used as is; don't use adapters to lift the ground (unless you're using a "star ground network"—see below). If you hear hum or buzz from a device that uses a two-prong plug (or an external two-prong AC/DC adapter), you can try reversing the plug in the socket. If that doesn't work, you may need to physically ground that device's chassis by connecting a wire (called a *strap*) from it to a grounded piece of metal. Some pieces of equipment have a screw-type ground post to which the strap can be connected; if not, you can attach some kind of metallic binding post to the case itself. If you are using rack-mounted audio devices and are experiencing hum or buzz, there's a simple test to determine the source of the problem: while keeping all devices powered on and connected with audio cabling, physically remove each device, one by one, from the rack. If the hum disappears when a particular device is removed, you'll know that device is probably the culprit.

We also recommend that you use balanced audio cabling and connectors wherever possible. The MPL 1204 provides electronically balanced inputs for all line channel inputs and for its Main outputs. The wiring diagram in the "Connecting The MPL 1204" section of this manual (page 11) shows how 1/4" TRS (Tip/Ring/Sleeve) and XLR connectors should be wired for use with these inputs and outputs.

In addition, you can minimize possible interference by planning your audio, electrical, and computer cable runs so that they are as far apart from one another as possible and so they don't run parallel to one another. If they have to cross, try to ensure that they do so at a 90° angle (that is, perpendicular to one another). In particular, try to keep audio cabling away from external AC/DC adapters.

If you're using the MPL 1204 in a fixed location such as a recording studio, you may want to invest the time and money into creating a *star ground network*. This is by far the best technique for avoiding grounding problems. It involves using a formidable ground source such as a cold water pipe or a copper spike driven into the earth. A thick grounding cable is connected to that source and then brought to a central distribution point; from there, individual cables are connected to each piece of equipment. This setup also requires that you lift the ground plug of all three-prong AC connectors, so there is the possibility of danger if it is done incorrectly. We strongly recommend that you contract with a qualified professional to carry out this or any kind of electrical work.

Another, less common problem you may encounter is that of *oscillation* (a ringing tone), which, apart from being annoying, is potentially dangerous to your speakers. This is generally caused either by poor outside wiring or by returning a signal out of phase (most commonly from an outboard signal processor). If audible oscillation occurs, try isolating each input signal by turning down all other inputs. If one signal alone is causing the problem, you should be able to eliminate the oscillation by reversing that signal's phase (many signal processors have a switch that allows you to do this).

# Busing, Submixing and Channel Muting

As we've seen, the MPL 1204 uses a system of four *buses*—pathways through which signal can be routed. The four MPL 1204 bus faders control the overall level of the signal being output through the four buses. When the “L/R” switches above each bus fader are pressed in, the signal from that bus is also routed to the Main and Control Room outputs. In this case, buses 1 and 3 are automatically routed to the left side of the Main and Control Room outputs and buses 2 and 4 are automatically routed to the right side of the Main and Control Room outputs. This four-bus system (which can eventually mix down to a single stereo output) gives you a great deal of flexibility in terms of signal flow.

For example, you may want to connect the MPL 1204 to a four-track cassette or open-reel tape recorder. One good way to do this is to route each of the four individual bus outputs to a tape input, and to bring each of the four tape outputs back to individual channels. With this setup, to record onto track 1, you'd route one or more instrument or microphone channels to bus 1 (via the channel “Mute 3/4” switch); to record onto track 3, you'd route them to bus 3, etc. To connect the MPL 1204 to an eight-track digital recorder (such as the Alesis ADAT™ or Tascam DA88™ system), simply use signal splitters or patchbay mults to combine the signal from buses so that bus 1 is routed to tape inputs 1 and 5; bus 2 to tape inputs 2 and 6; bus 3 to tape inputs 3 and 7; and bus 4 to tape inputs 4 and 8. See the “Applications” section on page 23 in this manual for more information on using the MPL 1204 as a recording mixer.

Another important plus is that you can use each bus to set up a *submix* within your overall mix. For example, let's suppose that you're using the MPL 1204 to do live sound and you have eight microphones on the drum kit—separate mics for the bass and snare drums as well as for the hi-hat, another mic for each of three tom-toms, and an overhead pair for picking up cymbals. To get all this signal into the MPL 1204, you're going to have to use eight mono channels. During a sound check, you'll usually start with the drums, working to get the blend of the eight different drum mics just right. After that's done, the next step is typically to start bringing in the other instruments. During the gig, however, you may need to raise or lower the overall level of the drums, but you surely won't want to upset the blend you so carefully set up. This won't be easy to do if you have to move eight faders at once! The solution is to use the busing system provided by the MPL 1204—route the eight drum channels to one pair of buses and all other instruments to the other pair. Now you can adjust the overall level of the entire drum mix by moving just two bus faders!

You can also use the MPL 1204 bus switches to *mute* particular channels (that is, remove them temporarily from the overall mix without having to change their fader position). To do this, keep bus faders 3 and 4 down at their “∞” position (no signal) and use buses 1 and 2 for your overall mix. Then, to mute a signal, all you have to do is press that channel's “Mute 3/4” switch; the signal will be rerouted to buses 3 and 4 (which are off) and will be removed from the mix you hear. To restore the signal (that is, *unmute* it), all you have to do is press that channel's “Mute 3/4” switch again—since its fader hasn't been moved, the sound will come back at the same level as before.

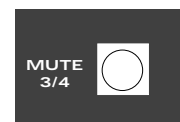
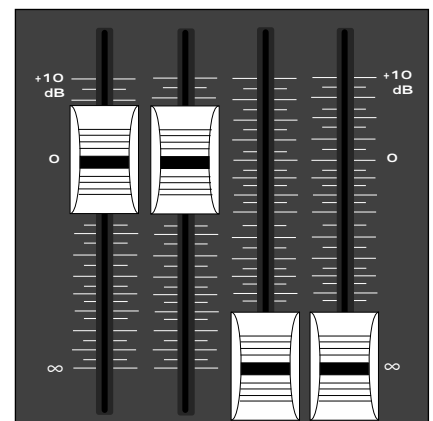
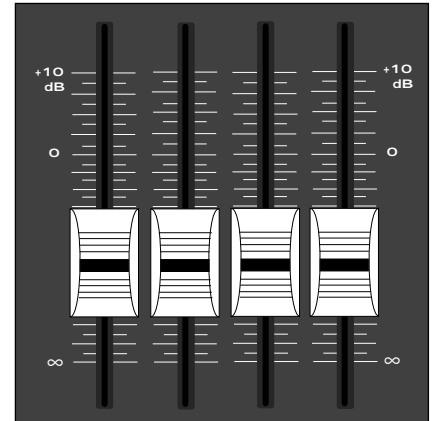

---

# Using Pan



The final Main output of the MPL 1204 is stereo—that is, there are two discrete Main output jacks (and two discrete Control Room output jacks), labeled “left” and “right,” which will normally be routed to two discrete speakers.\* Because of this, you will usually be working with a stereo field that ranges from hard left to hard right. The MPL 1204 provides twelve monophonic input channels, each with its own dedicated Pan control. The Pan circuitry in the MPL 1204 always keeps the overall level constant, regardless of pan position. Here’s how it works: When the Pan knob is placed at its center (detented) position, signal is sent equally to both left and right outputs of the selected bus (depending upon the setting of the channel’s Mute 3/4 switch, as described in #5 on page x). When moved left of center, less signal is sent to the right output and more signal is sent to the left output (making the sound appear left of center) and when moved right of center, less signal is sent to the left output and more signal is sent to the right output (making the sound appear right of center). To route a signal hard left or right, place the pan knob either fully counterclockwise or fully clockwise.

You can use stereo panning creatively in a variety of ways: For example, you might want to have guitars coming from one speaker and keyboards from another, or you might use panning to “spread” the signal from a piano miked with two microphones—one over the bass notes (panned left) and the other over the treble notes (panned right). In live performance, you may want to resist the temptation to pan anything completely hard left or right, since some members of the audience not seated in the center of the venue may miss some signal altogether. In these circumstances, you’re best to use modest panning, with signals routed no further than the 9 o’clock and 3 o’clock positions.

\* You can, of course, also use the MPL 1204 monophonically—simply route the same signal to both the left and right outputs.

# Using Equalization

One of the most exciting aspects of using a mixer such as the MPL 1204 is the ability to shape a sound, using a process called *equalization*. But there are few areas of sound engineering more misunderstood than equalization, and, just as good EQ can really help a sound, bad EQ can really hurt it, so read on...

Every naturally occurring sound consists of a broad range of pitches, or *frequencies*, combined together in a unique way. This blend is what gives every sound its distinctive tonal color. The EQ section in a mixer allows you to alter a sound by boosting or attenuating specific frequency areas. The MPL 1204 provides independent three-band equalization controls for each of its channels (the same equalization is applied to both the odd-numbered [left] input and the even-numbered [right] input). Each EQ knob is labeled with the maximum amount of cut or boost provided ( $\pm 15$  dB in the case of Low and High frequencies, and  $\pm 12$  dB in the case of the Mid frequency). The Mid frequency control utilizes a resonant (“bell”) peaking curve, while the Low and High frequency controls utilize *shelving* curves. This means that, in the case of the Mid EQ control, frequencies around 1 kHz are affected; in the case of the Low EQ control, frequencies around or below 100 Hz are affected; and, in the case of the High EQ control, frequencies around or above 10 kHz are affected. We provided these particular frequency areas because they have maximum impact on musical signals—that’s why they are sometimes known as “sweet spots.”

When an EQ knob is in its center detented position (“0”), it is having no effect. When it is moved right of center, the selected frequency area is being boosted; when it is moved left of center, the frequency area is being attenuated.

In most instances, the best way to approach equalization is to think in terms of which frequency areas you need to attenuate, as opposed to which ones you need to boost (boosting a frequency area also has the effect of boosting the overall signal; too much EQ boost can actually cause overload). Be aware of the phenomenon of *masking*, where loud sounds in one frequency range obscure softer sounds in the same range; by cutting EQ “notches” in a loud signal, you can actually make room for a softer one to shine through. And try not to think of EQ as a miracle worker—no amount of equalization can put a singer in tune or remove the distortion from an overloaded input signal! The key is to get the signal right in the first place, by using correct gain structure and mic placement.

Although the specific EQ you will apply to a signal is very much a matter of personal taste, here are a few general suggestions: Boosting the low frequency of instruments such as bass drums or bass guitar will add warmth and make the sound “fatter”; conversely, you may want to attenuate the low frequency component of instruments such as cymbals, high-hats, and shakers so as to “thin” them out. Boosting Mid frequencies can be used to help bring out vocals or guitars, while attenuating them can help to reduce “boxiness.” Be careful not to boost high frequencies too much or you risk adding hiss to the signal, though just a touch can help add “shimmer” to an acoustic guitar, ride cymbal, or high-hat. Finally, because the MPL 1204 High and Low EQ utilize shelving curves, attenuated High settings can be used to reduce hiss (which is composed almost exclusively of high frequencies) or attenuated Low frequencies can be used to reduce rumble (which is composed almost exclusively of low frequencies).



# Using Aux Sends and Returns

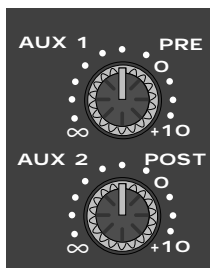

The MPL 1204's two Auxiliary sends allow you to combine the signal from multiple channels and send the resulting mix to external devices such as effects processors. When an Aux send knob is at its 2 o'clock "0" position, the signal is routed with unity gain (that is, no boost or attenuation). As it is turned clockwise from the 0 position, the signal is boosted; as it is turned counterclockwise from the 0 position, it is attenuated. Aux send 1 is *pre-fade* (but post-eq); that is, the level of the signal is determined solely by the channel's Trim control and its EQ settings. In contrast, Aux send 2 is *post-fade* (and post-eq); that is, the level of the signal is affected by the channel's Trim control, equalizer settings, and Level control.

The MPL 1204 also provides two stereo Auxiliary returns. These allow you to return signal from outboard devices in stereo pairs. Each of the stereo Auxiliary returns is somewhat similar to a stereo channel, except that a signal being brought into to a channel can be equalized if necessary and optionally sent on to other outboard devices (via Aux sends or channel inserts). In practice, you'll probably want to use the Auxiliary returns to bring in signal from connected effects processors. If the effects processors have stereo outputs, they should be connected to both the left and right Aux return inputs so that their stereo integrity is retained. If they have mono outputs, you can route them to either the left or right inputs and then use the Aux return Balance control to adjust the relative level of each paired signal. In this way, you can actually connect up to four monophonic devices to the MPL 1204's Aux return section.

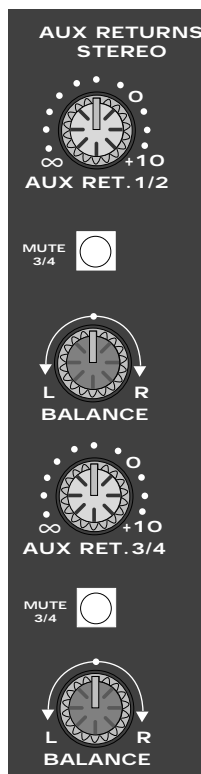

When an Aux return Balance knob is placed at its center (detented) position, both the left and right signals are at equal strength. When moved left of center, the left input signal remains the same but the right input signal is attenuated; when the knob is moved right of center, the right input signal remains the same but the left input signal is attenuated. When placed fully counterclockwise, only the left input is heard (panned hard left); when placed fully clockwise, only the right input is heard (panned hard right).

Signal arriving at the left Aux return input is automatically panned hard left and signal arriving at the right input is automatically panned hard right. The MPL 1204 Aux return jacks are unbalanced stereo inputs, with the tip carrying the left input signal and the ring carrying the right input signal (the sleeve carries common ground), as shown in the wiring diagram on page 12 of this manual. Insertion of a monophonic 1/4" jack into an Aux return will result in the incoming signal being automatically routed to the left input only (and therefore panned hard left).

The signal arriving at each of the two stereo Aux returns can be routed to either of the two bus pairs (1/2 or 3/4) with the use of the associated Aux Return bus switch (as described in #2 on page 6). The signal can then be routed to the Master and Control Room outputs by pressing in the associated bus L/R switch (as described in #14 on page 8). Note that Aux Returns cannot be soloed and so cannot be monitored over headphones.

In addition to using Auxiliary sends and returns to access outboard devices, the MPL 1204 also provides *channel inserts* for each of its twelve input channels. These should be used when you want to affect just one input signal, as opposed to signal from several inputs—most often, this will be for dynamic processing purposes (such as outboard equalization, compression/limiting, or noise gating). You can also use the channel insert sends as post-eq (but pre-fade) *direct outputs*, if you need to route a single monophonic signal to an external device such as a tape deck.

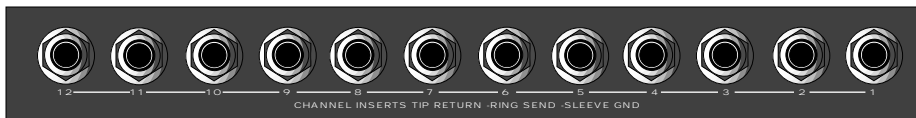

The MPL 1204 also provides inserts for each of its four buses—appropriately enough, these are called *bus inserts*. These allow you to process a group of signals simultaneously (such as a drum submix being sent to a single track of a tape recorder) at unity gain. Because they provide a unity gain input and output, bus inserts can also be used to link multiple MPL 1204s or to bring the output from another mixer into the MPL 1204 without taking up channel line inputs. See the “Linking the MPL 1204 With Other Mixers” Application on page 26 in this manual for more information.

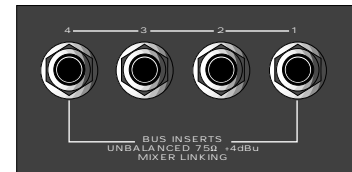

All MPL 1204 insert jacks accept 1/4" TRS plugs, with the ring carrying the send signal and the tip carrying the return signal; this will normally be connected to a Y-cord (see the “Connecting The MPL 1204” section on page 12 in this manual for a wiring diagram). This configuration is sometimes known as an “effects loop,” since the signal is sent and returned over the same cable.

If nothing is plugged into the channel or bus insert jacks, they have no effect—but if you connect them to a passive device like a patchbay, you’ll need to *normal* (permanently connect) or *half-normal* (connection is made unless overridden by a patch cord) the send to the return. Channel insert signals are returned just before channel Level controls, and Bus insert signals are returned just before the Bus faders. For this reason, you’ll have to be careful to set the output of external devices connected this way to unity gain.

# PFL/AFL Soloing



The MPL 1204 provides two options for soloing input signals in headphones connected to the front panel headphone jack—*Pre Fade Listen (PFL)* and *After-Fade Listen (AFL)*. The Solo switch in the main section (#8 on page 7) allows you to choose between these two modes of operation. Although they may at first glance appear similar (and although both are non-mix-destructive), there is in fact a significant difference between the two.



The main function of PFL is to allow you to check that a signal is actually arriving at a particular input. When the MPL 1204 is in PFL mode and a channel Solo switch is pressed in, the pre-fader (but post-eq) signal of that channel alone is routed to the headphone output. The Bus outputs, Main outputs, and Control Room outputs are *not* interrupted during a PFL solo, so you can press any channel Solo switch even during recording or live performance without affecting the main signal flow. This also makes it possible for you to correctly cue up a tape or CD before bringing it into the main mix (tape or CD players connected to the MPL 1204's rear panel Tape/CD input jacks can be routed to channels 11 and 12 by pressing in the main section "Tape" switch).

The main drawback to using PFL mode, however, is that it does not allow you to hear a signal *in context*. Because the PFL soloed signal is monitored pre-fader, it may sound considerably louder or softer than it actually is in the overall mix, depending upon the current position of the channel Level control.

Therefore, you may in some circumstances prefer to use AFL mode, which provides post-fade (and post-eq) soloing. When the MPL 1204 is in AFL mode and a channel Solo switch is pressed in, the post-fader, post-EQ signal of that channel alone is routed to the headphone output. Like PFL, AFL is non-destructive to your mix—the Bus outputs, Main outputs, and Control Room outputs are *not* interrupted during an AFL solo. However, over the headphones, you'll hear the AFL soloed signal at its current level.

LEDs in the meter section allow you to see at a glance which mode the MPL 1204 is in. The leftmost LED (labeled "PFL") lights steadily red when the mixer is in PFL mode, while the center left LED (labeled "AFL") lights steadily red when the mixer is in AFL mode. In both PFL and AFL modes, you'll hear the soloed channel with its EQ settings and all effects being applied and returned via the channel insert. Note that headphone monitoring in the MPL 1204 is mono only (channel Pan controls have no effect) and that, since Aux returns cannot be soloed, they cannot be monitored over headphones.



Here are four suggested applications for the MPL 1204; bear in mind that your particular circumstance may dictate changes in these suggested signal connections and routings.

## Application 1 - Using The MPL 1204 As A Recording Mixer

The MPL 1204 is optimized for use as a recording mixer with multitrack digital or analog recorders. As shown in the illustration below, microphones and line level signals are connected to various channel inputs. Signal processors are connected to Aux sends and returns and to channel inserts as required, with Aux send 1 (which is pre-fader) driving a headphone amplifier for cue mixes. The Control Room outputs are connected to a power amplifier driving studio monitors. The Main outputs are connected to the inputs of a two-track or DAT recorder, with the outputs of the two-track or DAT recorder connected to the MPL 1204 tape inputs. The four Bus outputs are connected to the inputs of a multitrack recorder, with the multitrack outputs connected to four MPL 1204 channel line inputs. During mixdown, those channels carrying the multitrack outputs are routed to bus 1/2 (via their channel "Mute 3/4" switches), with buses 1 and 2 routed to the Main L/R outputs (by pressing in their Bus "L/R" switches). To listen back to the mix, the channels carrying the two-track outputs (channels 11 and 12) are routed to bus 3/4 (via their channel "Mute 3/4" switch); then connect buses 3 and 4 to the Control Room outputs by pressing in their Bus "L/R" switches.

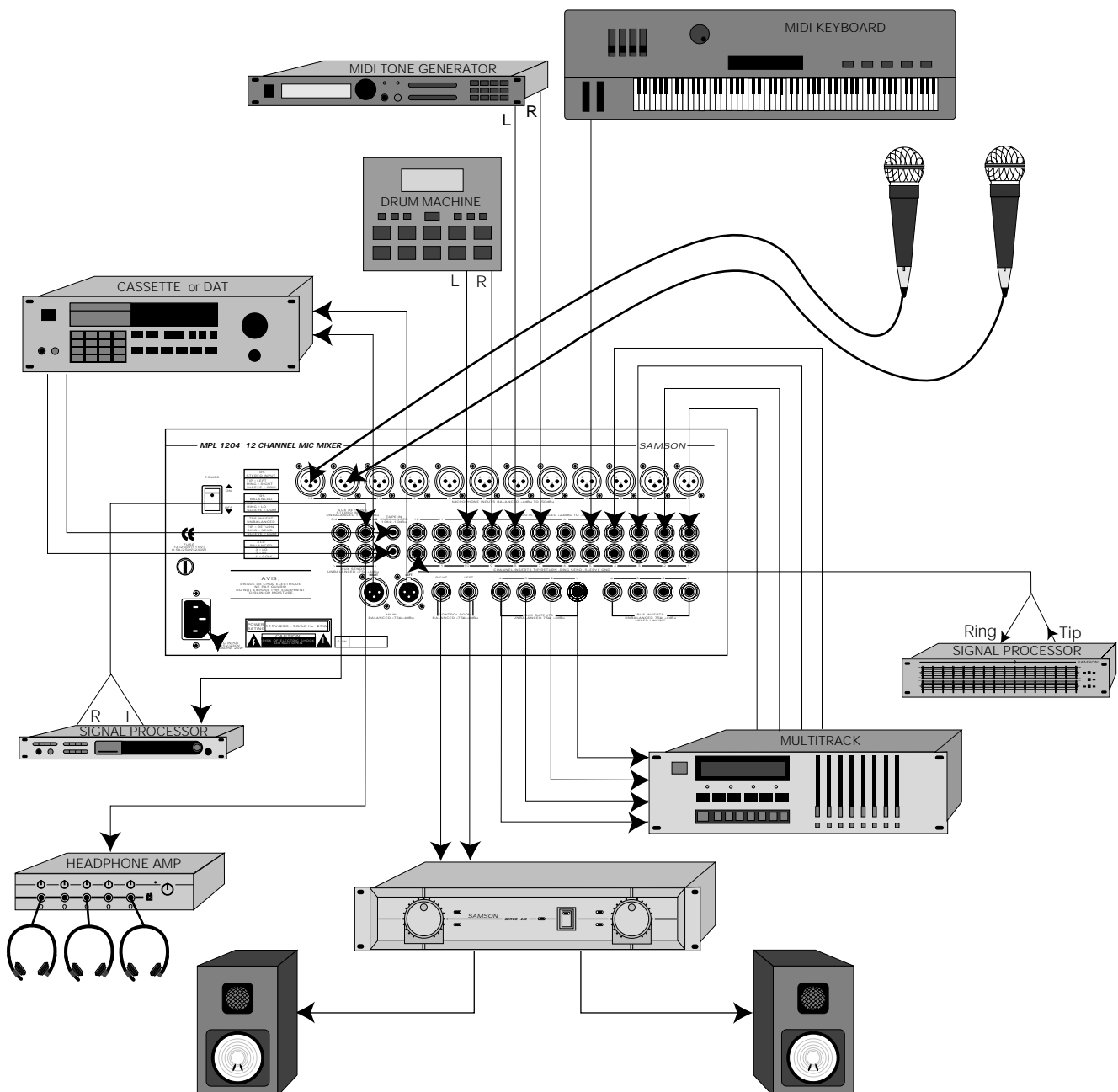

# Applications

## Application 2 - Using The MPL 1204 As A Main Live Mixer

Here, the MPL 1204's Main output is connected to the input of a power amplifier, and, from there, to PA speakers. Microphones and line level signals are connected to various channel inputs, and a two-track tape deck is connected to the Tape/CD inputs. A submix from Aux send 1 (which is pre-fade) is connected to the input of a second power amplifier driving onstage monitor speakers so that performers can receive a monitor mix independent of the house mix. Signal is being sent to an external signal processor via Aux send 2, with a stereo return from that processor is connected to Aux return 1/2. Another signal processor is connected to channel insert 1 so as to affect the signal coming from the mic connected to channel 1, and a third signal processor is connected to Bus insert 4 so that a submix of all channels routed to bus 4 are processed simultaneously.

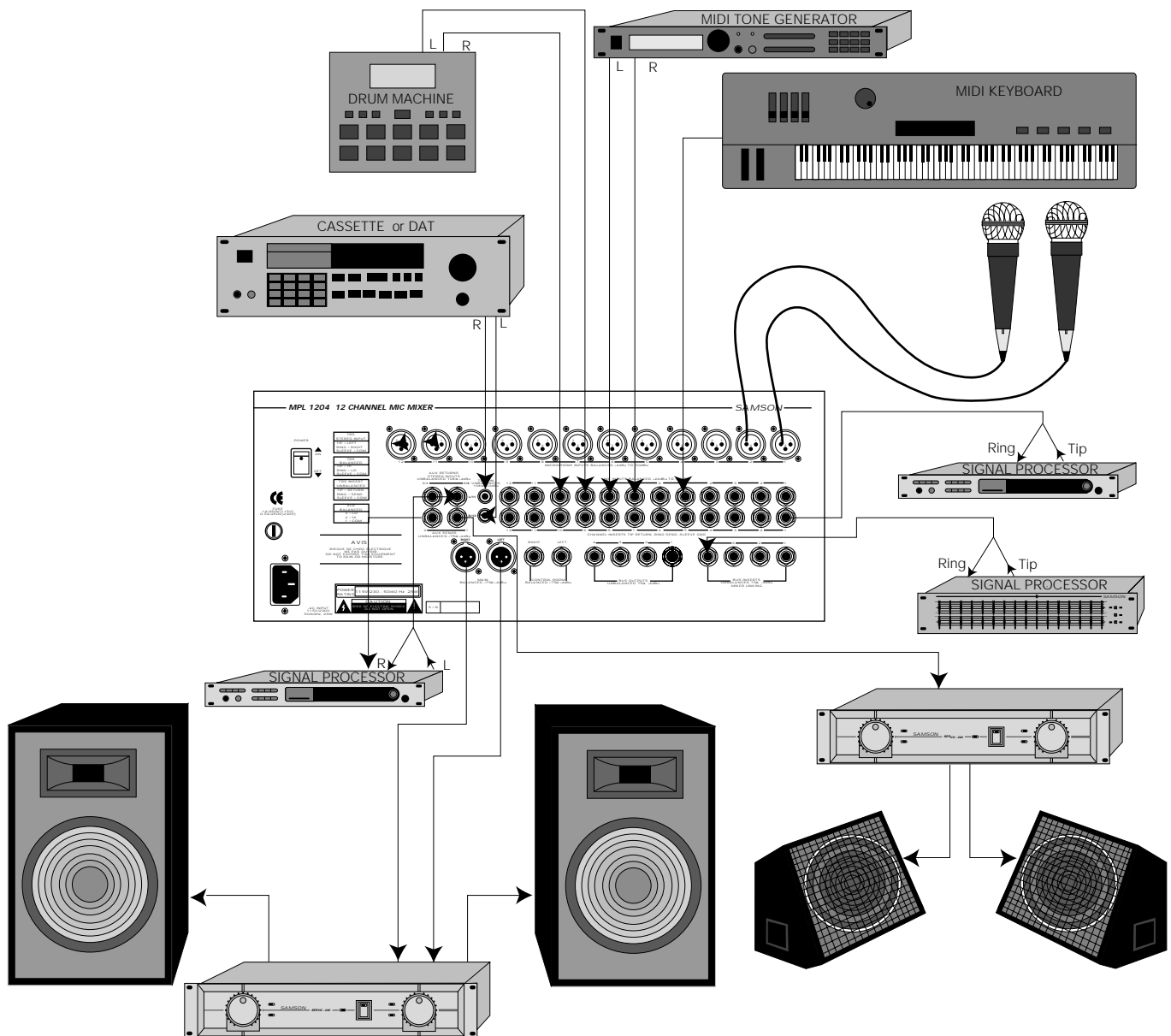

## Application 3 - Using The MPL 1204 As A Keyboard Submixer

Here, various keyboards and MIDI tone generators are connected to the channel line inputs of the MPL 1204. Signal processors are connected to Aux sends and returns and to channel inserts as required. The Main output can then be routed to a stereo input channel of a live performance or recording mixing console, with the performer having complete control over the blend of signals being provided to the sound engineer.

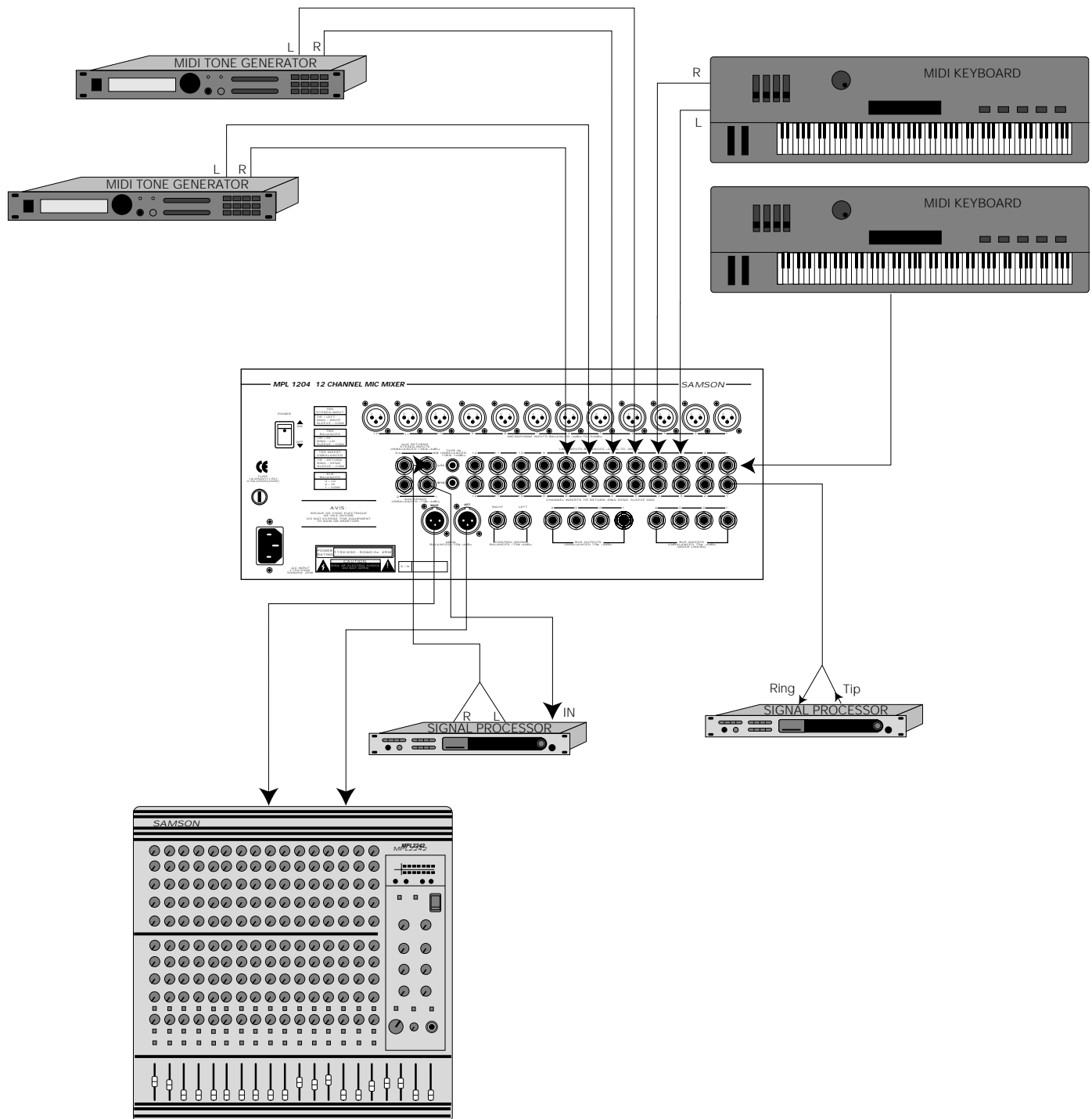

# Applications

## Application 4 - Linking The MPL 1204 With Other Mixers

The provision of four rear-panel Bus inserts makes it easy to link multiple MPL 1204s or to link the MPL 1204 with other mixers, without the need to use up channel line inputs. As shown in this illustration, simply connect the main output of another mixer to one or two MPL 1204 Bus inserts (use two for stereo linking). The signal from that mixer will then be "submixed" into that bus at unity gain; you can then use that bus fader to blend its relative level with that of signal routed to other MPL 1204 buses.

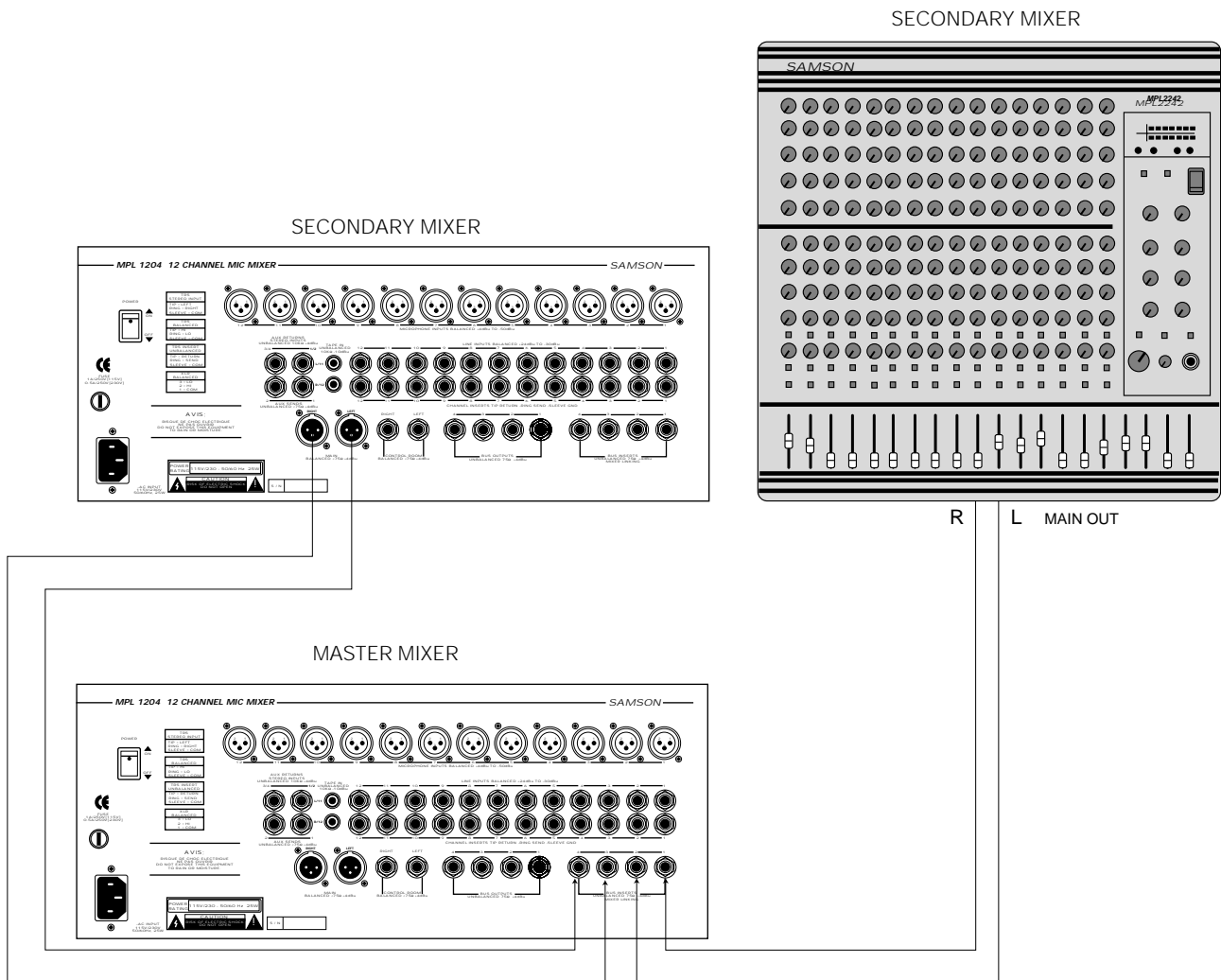

# Appendix A: Block Diagram

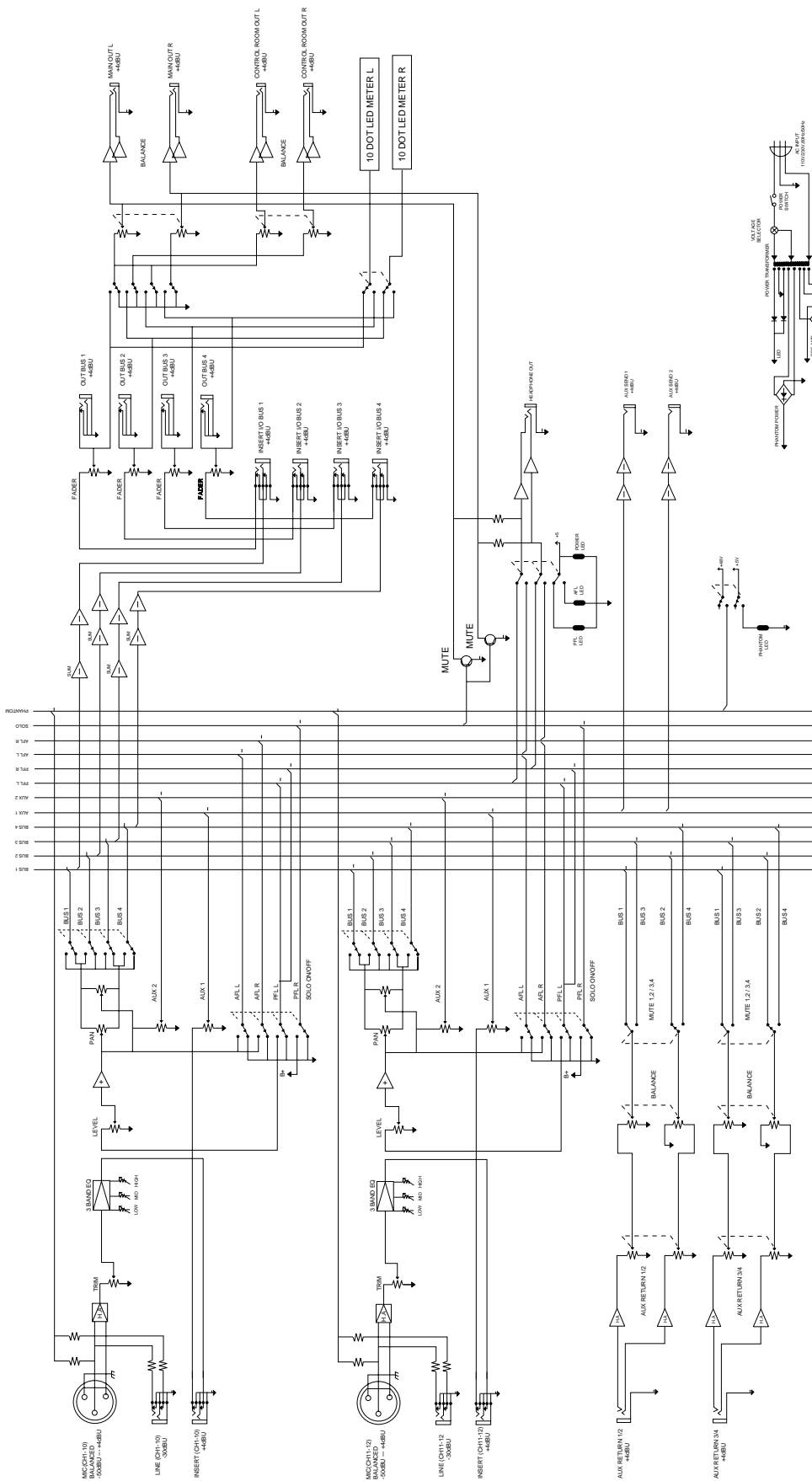

# Specifications

	Normal	Limit
<b>1. Frequency Response (<math>\pm 3</math> dB)</b>		
Mic in to Main out	DC ~ 65 kHz	20 Hz - 50 kHz
Mic in to Aux Send	DC ~ 65 kHz	20 Hz - 50 kHz
Aux return to Main out	DC ~ 160 kHz	20 Hz - 50 kHz
Tape in to Main out	DC ~ 65 kHz	20 Hz - 50 kHz
<b>2. Total Harmonic Distortion (20 Hz to 20 kHz, with 30 kHz LPF)</b>		
Mic in to Main out (Trim max)	0.06%	< 0.1 %
Line in to Main out (Trim min)	0.009%	< 0.03 %
Aux return to Main out	0.07%	< 0.03 %
<b>3. Signal to Noise Ratio (30 kHz LPF)</b>		
Mic in to Main out (Trim max)	87 dB	82 dB
Mic in to Main out (Trim min)	70 dB	65 dB
<b>4. Maximum Voltage Gain (Trim min/max)</b>		
Mic in to Channel insert		0 / 54 dB
Mic in to Bus insert		10 / 64 dB
Mic in to Bus out		20 / 74 dB
Mic in to Main out / Control Room out		30 / 84 dB
Mic in to Aux send 1		10 / 64 dB
Mic in to Aux send 2		20 / 74 dB
Line in to Main out		10 / 64 dB
Aux return to Main out		30 dB
Tape in to Main out		44 dB
<b>5. Residual Noise (with 30 kHz LPF, EQ center, Trim min)</b>		
Main min		-97.5 dBu
Main max, Bus Fader min		-80.0 dBu
Main max, Bus Fader min, all channel VR min		-62.0 dBu
Main max, Bus Fader min, all channel VR max		-52.0 dBu
<b>6. Equalizer</b>		
High (10 kHz)	$\pm 12$ dB	$\pm 15$ dB
Mid (1 kHz)		$\pm 12$ dB
Low (100 Hz)	$\pm 12$ dB	$\pm 15$ dB
<b>7. Crosstalk (@1 kHz, with EQ center)</b>		
Channel vs. Channel	85 dB	80 dB
Input vs. Output	85 dB	80 dB
<b>8. Headphone Output (@ 600 ohm, 1 kHz)</b>		
	100 mW	120 mW
<b>9. Dimensions</b>		
		19 in (w) x 7.1 (d) x 7 (h) 482 mm (w) x 179 (d) x 177 (h)
<b>10. Weight</b>		
		15.9 lbs • 7.2 kg
<b>11. AC Power</b>		
	115 Vac • 60 Hz for UL and CSA version 230 Vac • 50/60 Hz for BSI and Central Europe version 100 Vac • 50/60 Hz for Japan version	

Produced by *On The Right Wavelength* for Samson Technologies Corp.

Copyright 1997, Samson Technologies Corp.

Printed March 1997

Samson Technologies Corp.  
575 Underhill Blvd.  
P.O. Box 9031  
Syosset, NY 11791-9031  
Phone: 1-800-3-SAMSON (1-800-372-6766)  
Fax: 516-364-3888

## Free Manuals Download Website

<http://myh66.com>

<http://usermanuals.us>

<http://www.somanuals.com>

<http://www.4manuals.cc>

<http://www.manual-lib.com>

<http://www.404manual.com>

<http://www.luxmanual.com>

<http://aubethermostatmanual.com>

Golf course search by state

<http://golfingnear.com>

Email search by domain

<http://emailbydomain.com>

Auto manuals search

<http://auto.somanuals.com>

TV manuals search

<http://tv.somanuals.com>