

dB500a

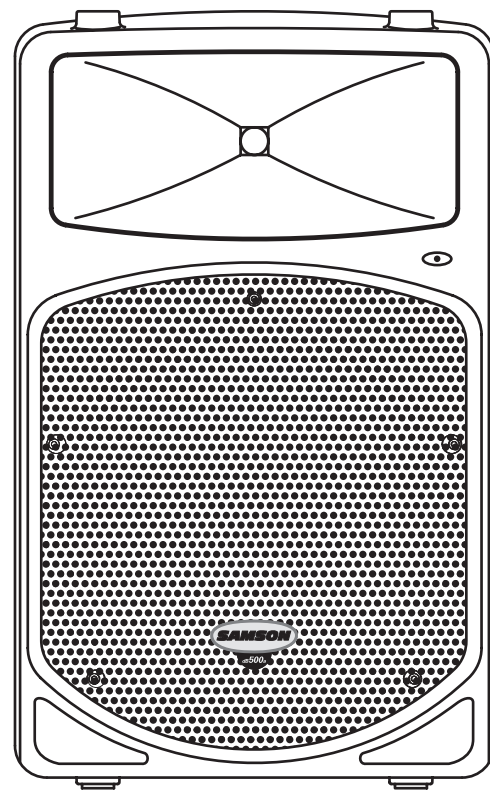

500 WATT BI-AMPED ACTIVE LOUDSPEAKER

Owners Manual



Safety Instructions/Consignes de sécurité/Sicherheitsvorkehrungen/Instrucciones de seguridad



WARNING: To reduce the risk of fire or electric shock, do not expose this unit to rain or moisture. To reduce the hazard of electrical shock, do not remove cover or back. No user serviceable parts inside. Please refer all servicing to qualified personnel. The lightning flash with an arrowhead symbol within an equilateral triangle, is intended to alert the user to the presence of uninsulated "dangerous voltage" within the products enclosure that may be of sufficient magnitude to constitute a risk of electric shock to persons. The exclamation point within an equilateral triangle is intended to alert the user to the presence of important operating and maintenance (servicing) instructions in the literature accompanying the product.

Important Safety Instructions

1. Please read all instructions before operating the unit.
2. Keep these instructions for future reference.
3. Please heed all safety warnings.
4. Follow manufacturers instructions.
5. Do not use this unit near water or moisture.
6. Clean only with a damp cloth.
7. Do not block any of the ventilation openings. Install in accordance with the manufacturers instructions.
8. Do not install near any heat sources such as radiators, heat registers, stoves, or other apparatus (including amplifiers) that produce heat.
9. Do not defeat the safety purpose of the polarized or grounding-type plug. A polarized plug has two blades with one wider than the other. A grounding type plug has two blades and a third grounding prong. The wide blade or third prong is provided for your safety. When the provided plug does not fit your outlet, consult an electrician for replacement of the obsolete outlet.
10. Protect the power cord from being walked on and pinched particularly at plugs, convenience receptacles and at the point at which they exit from the unit.
11. Unplug this unit during lightning storms or when unused for long periods of time.
12. Refer all servicing to qualified personnel. Servicing is required when the unit has been damaged in any way, such as power supply cord or plug damage, or if liquid has been spilled or objects have fallen into the unit, the unit has been exposed to rain or moisture, does not operate normally, or has been dropped.

ACHTUNG: Um die Gefahr eines Brandes oder Stromschlags zu verringern, sollten Sie dieses Gerät weder Regen noch Feuchtigkeit aussetzen. Um die Gefahr eines Stromschlags zu verringern, sollten Sie weder Deckel noch Rückwand des Geräts entfernen. Im Innern befinden sich keine Teile, die vom Anwender gewartet werden können. Überlassen Sie die Wartung qualifiziertem

Fachpersonal. Der Blitz mit Pfeilspitze im gleichseitigen Dreieck soll den Anwender vor nichtisolierter "gefährlicher Spannung" im Geräteinnern warnen. Diese Spannung kann so hoch sein, dass die Gefahr eines Stromschlags besteht. Das Ausrufezeichen im gleichseitigen Dreieck soll den Anwender auf wichtige Bedienungs- und Wartungsanleitungen aufmerksam machen, die im mitgelieferten Informationsmaterial näher beschrieben werden.

Wichtige Sicherheitsvorkehrungen

1. Lesen Sie alle Anleitungen, bevor Sie das Gerät in Betrieb nehmen.
2. Bewahren Sie diese Anleitungen für den späteren Gebrauch gut auf.
3. Bitte treffen Sie alle beschriebenen Sicherheitsvorkehrungen.
4. Befolgen Sie die Anleitungen des Herstellers.
5. Benutzen Sie das Gerät nicht in der Nähe von Wasser oder Feuchtigkeit.
6. Verwenden Sie zur Reinigung des Geräts nur ein feuchtes Tuch.
7. Blockieren Sie keine Belüftungsöffnungen. Nehmen Sie den Einbau des Geräts nur entsprechend den Anweisungen des Herstellers vor.
8. Bauen Sie das Gerät nicht in der Nähe von Wärmequellen wie Heizkörpern, Wärmeklappen, Öfen oder anderen Geräten (inklusive Verstärkern) ein, die Hitze erzeugen.
9. Setzen Sie die Sicherheitsfunktion des polarisierten oder geerdeten Steckers nicht außer Kraft. Ein polarisierter Stecker hat zwei flache, unterschiedlich breite Pole. Ein geerdeter Stecker hat zwei flache Pole und einen dritten Erdungsstift. Der breitere Pol oder der dritte Stift dient Ihrer Sicherheit. Wenn der vorhandene Stecker nicht in Ihre Steckdose passt, lassen Sie die veraltete Steckdose von einem Elektriker ersetzen.
10. Schützen Sie das Netzkabel dahingehend, dass niemand darüber laufen und es nicht geknickt werden kann. Achten Sie hierbei besonders auf Netzstecker, Mehrfachsteckdosen und den Kabelanschluss am Gerät.
11. Ziehen Sie den Netzstecker des Geräts bei Gewittern oder längeren Betriebspausen aus der Steckdose.
12. Überlassen Sie die Wartung qualifiziertem Fachpersonal. Eine Wartung ist notwendig, wenn das Gerät auf irgendeine Weise, beispielsweise am Kabel oder Netzstecker beschädigt wurde, oder wenn Flüssigkeiten oder Objekte in das Gerät gelangt sind, es Regen oder Feuchtigkeit ausgesetzt war, nicht mehr wie gewohnt betrieben werden kann oder fallen gelassen wurde.

ATTENTION: Pour éviter tout risque d'électrocution ou d'incendie, ne pas exposer cet appareil à la pluie ou à l'humidité. Pour éviter tout risque d'électrocution, ne pas ôter le couvercle ou le dos du boîtier. Cet appareil ne contient aucune pièce remplaçable par l'utilisateur. Confiez toutes les réparations à un personnel qualifié. Le signe avec un éclair dans un triangle prévient l'utilisateur de la présence d'une tension dangereuse et non isolée dans l'appareil. Cette tension constitue un risque d'électrocution. Le signe avec un point d'exclamation dans un triangle prévient l'utilisateur d'instructions importantes relatives à l'utilisation et à la maintenance du produit.

Consignes de sécurité importantes

1. Veuillez lire toutes les instructions avant d'utiliser l'appareil.
2. Conserver ces instructions pour toute lecture ultérieure.
3. Lisez avec attention toutes les consignes de sécurité.
4. Suivez les instructions du fabricant.
5. Ne pas utiliser cet appareil près d'une source liquide ou dans un lieu humide.
6. Nettoyez l'appareil uniquement avec un tissu humide.
7. Veillez à ne pas obstruer les fentes prévues pour la ventilation de l'appareil. Installez l'appareil selon les instructions du fabricant.
8. Ne pas installer près d'une source de chaleur (radiateurs, etc.) ou de tout équipement susceptible de générer de la chaleur (amplificateurs de puissance par exemple).
9. Ne pas retirer la terre du cordon secteur ou de la prise murale. Les fiches canadiennes avec polarisation (avec une lame plus large) ne doivent pas être modifiées. Si votre prise murale ne correspond pas au modèle fourni, consultez votre électricien.
10. Protégez le cordon secteur contre tous les dommages possibles (pincement, tension, torsion, etc.). Veillez à ce que le cordon secteur soit libre, en particulier à sa sortie du boîtier.
11. Déconnectez l'appareil du secteur en présence d'orage ou lors de périodes d'inutilisation prolongées.
12. Consultez un service de réparation qualifié pour tout dysfonctionnement (dommage sur le cordon secteur, baisse de performances, exposition à la pluie, projection liquide dans l'appareil, introduction d'un objet dans le boîtier, etc.).

PRECAUCION: Para reducir el riesgo de incendios o descargas, no permita que este aparato quede expuesto a la lluvia o la humedad. Para reducir el riesgo de descarga eléctrica, nunca quite la tapa ni el chasis. Dentro del aparato no hay piezas susceptibles de ser reparadas por el usuario. Dirija cualquier reparación al servicio técnico oficial. El símbolo del relámpago dentro del triángulo equilátero pretende advertir al usuario de la presencia de "voltajes peligrosos" no aislados dentro de la carcasa del producto, que pueden ser de la magnitud suficiente como para constituir un riesgo de descarga eléctrica a las personas. El símbolo de exclamación dentro del triángulo equilátero quiere advertirle de la existencia de importantes instrucciones de manejo y mantenimiento (reparaciones) en los documentos que se adjuntan con este aparato.

Instrucciones importantes de seguridad

1. Lea todo este manual de instrucciones antes de comenzar a usar la unidad.
2. Conserve estas instrucciones para cualquier consulta en el futuro.
3. Cumpla con todo lo indicado en las precauciones de seguridad.
4. Observe y siga todas las instrucciones del fabricante.
5. Nunca utilice este aparato cerca del agua o en lugares húmedos.
6. Limpie este aparato solo con un trapo suave y ligeramente humedecido.
7. No bloquee ninguna de las aberturas de ventilación. Instale este aparato de acuerdo a las instrucciones del fabricante.
8. No instale este aparato cerca de fuentes de calor como radiadores, calentadores, hornos u otros aparatos (incluyendo amplificadores) que produzcan calor.
9. No anule el sistema de seguridad del enchufe de tipo polarizado o con toma de tierra. Un enchufe polarizado tiene dos bornes, uno más ancho que el otro. Uno con toma de tierra tiene dos bornes normales y un tercero para la conexión a tierra. El borne ancho o el tercero se incluyen como medida de seguridad. Cuando el enchufe no encaje en su salida de corriente, llame a un electricista para que le cambie su salida anticuada.
10. Evite que el cable de corriente quede en una posición en la que pueda ser pisado o aplastado, especialmente en los enchufes, receptáculos y en el punto en el que salen de la unidad.
11. Desconecte de la corriente este aparato durante las tormentas eléctricas o cuando no lo vaya a usar durante un periodo de tiempo largo.
12. Dirija cualquier posible reparación solo al servicio técnico oficial. Deberá hacer que su aparato sea reparado cuando esté dañado de alguna forma, como si el cable de corriente o el enchufe están dañados, o si se han derramado líquidos o se ha introducido algún objeto dentro de la unidad, si esta ha quedado expuesta a la lluvia o la humedad, si no funciona normalmente o si ha caído al suelo.

Table of Contents

Introduction	2
dB500a Features	3
dB500a Layout	
Front View Layout	4
Rear Panel Layout	5
Quick Set-up	6
Positioning the dB500a	7
Operating the dB500a	8-9
Controls and Functions	8
Input and Output Connectors	9
Setting Up Your dB500a System	10-11
Using Speaker Stands	10
Stacking the dB500a	10
Permanent Installation	11
System Set-up	
Compact Lounge PA for Two	12
Live Band PA System with Monitors	13
dB500a Wiring Guide	14
Specifications	15

Copyright 2002, Samson Technologies Corp.

Printed November, 2003

Samson Technologies Corp.
575 Underhill Blvd.
P.O. Box 9031
Syosset, NY 11791-9031
Phone: 1-800-3-SAMSON (1-800-372-6766)
Fax: 516-364-3888
www.samsontech.com

Introduction

Congratulations on purchasing the Samson dB500a! The dB500a speaker system by Samson takes the concept of powered PA systems to a new level. By combining 500 watts of power, advanced active processing and the highest quality speaker and cabinet components, the dB500a provides studio quality sound for any kind of live application. The monitor features a super heavy-duty, custom designed 15-inch low frequency driver and a 1.75 inch titanium diaphragm high frequency driver on a 1" throat, wide dispersion horn. The dB500a offers crystal-clear audio and an ultra-wide sound field. The top end is clean, smooth and vivid. The low-end is enormous. The dB500a is powered by a Class G amplifier that pumps 400 Watts to the low frequency driver and a Class AB amp that provides 100 Watts to the high frequency section—more than enough power to fill any large club. The efficient Class G amplifier design provides the power to deliver transient spikes with incredible punch and sonic purity. The dB500a goes beyond concert-quality to studio-quality thanks to Samson's exclusive Optimax processing. Optimax processing uses sophisticated circuitry to compress and limit output at ideal levels. This allows the dB500a to provide huge volume levels without sacrificing low end. The dB500a offers a practical back-panel, mixer-like preamp section that provides mic and line inputs with individual input level controls. Controls for the selectable low pass filter and Optimax dynamics are also included. The trapezoidal shape of the speaker cabinet offers more than just superior acoustics, not only is it a front-firing PA speaker, the dB500a's are also designed to operate as wedge-style monitors. The cabinet's right and left side panels are joined at different angles, so depending on the side you choose, you get a different dispersion angle, allowing for greater flexibility on stage. Adding to the dB500a's practical design is a catalog of mounting options. The compact cabinet can be easily stacked, permanently installed, mounted using the integral 1 3/8" pole mount receptacle or suspended using the ten built-in fly points. With the dB500a, setup and break down is quick and easy. Heavy-grade steel grill, scuff-resistant textured finish and rigid corners offer excellent protection against wear and tear. As fixed sound reinforcement or as a durable, great-sounding road PA, the dB500a active monitor is ideal for sound professionals and performers looking for serious power and studio monitor sound quality from a PA speaker system.

In these pages, you'll find a detailed description of the features of the dB500a PA system, as well a description of its front and rear panels, step-by-step instructions for its setup and use, and full specifications. You'll also find a warranty card enclosed—please don't forget to fill it out and mail it in so that you can receive online technical support and so we can send you updated information about these and other Samson products in the future.

With proper care and adequate air circulation, your dB500a will operate trouble free for many years. We recommend you record your serial number in the space provided below for future reference.

Serial number: _____

Date of purchase: _____

Should your unit ever require servicing, a Return Authorization number (RA) must be obtained before shipping your unit to Samson. Without this number, the unit will not be accepted. Please call Samson at 1-800-3SAMSON (1-800-372-6766) for a Return Authorization number prior to shipping your unit. Please retain the original packing materials and if possible, return the unit in the original carton and packing materials.

dB500a Features

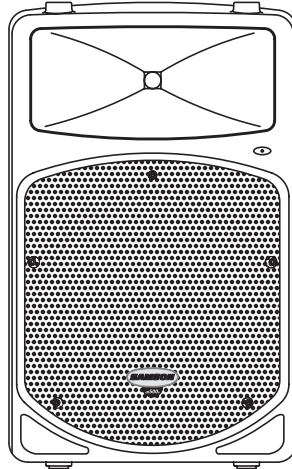

The Samson dB500a active two-way loudspeaker is an all-in-one solution for live sound. Here are some of its main features:

- Two-way Active Loudspeaker – Standard speaker stand receptacle, 15 and 30 degree monitor angles, arrayable with 10 Fly Points.
- Custom designed, heavy-duty, 15-inch low frequency driver with a 2.5-inch voice coil and 50 oz. magnet.
- 1" Throat, high-frequency compression driver with 1.75-inch titanium diaphragm and 75 oz. magnet structure.
- Efficient 400 watt, Class G power amplifier for low frequency transducer with High Speed, High Current MOSFET rail switches.
- 100 watt class AB amplifier for high frequency compression driver.
- Massive torroidal power transformer.
- Sophisticated, multi-band dynamics processor with audibly transparent switchable limiting.
- Internal 24 dB/octave time aligned electronic crossover.
- Separate bass and treble controls.
- Defeatable low cut filter.
- Balanced microphone input with level control and Phantom Power for condenser microphones.
- Balanced line level input with level control.
- Rugged, road-worthy construction for high reliability.
- Multi-point protection for all fault conditions.
- Quality build and rugged construction ensure reliable performance from venue to venue.
- Three-year extended warranty.

dB500a Layout

dB500a Front View Layout

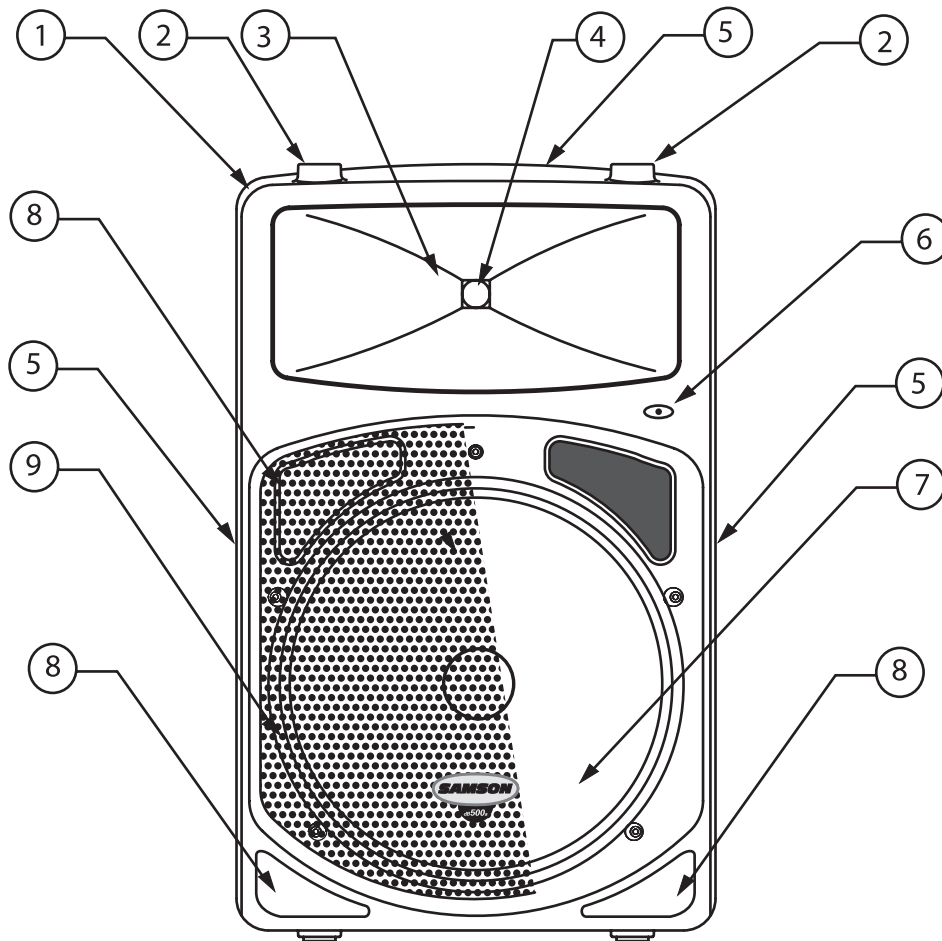

- ① **Enclosure** – Rugged polypropylene plastic enclosure.
- ② **Stacking Bumper** – Gender mating bumpers for stacking dB500's.
- ③ **Wide Dispersion Horn** – 1 inch throat, 60 x 90 degree wide dispersion horn provides extensive coverage and linear off-axis response.
- ④ **Titanium Compression Driver** – Edge-wound copper voice coil, 1.75-inch (44mm), titanium diaphragm with 1-inch throat boasting high SPL while sounding smooth and sweet.
- ⑤ **Handle** – One of three, ultra oversized, rubber grip carry handles.
- ⑥ **Power LED** – Blue Light Emitting Diode illuminates indicating the unit is powered on and ready for operation.
- ⑦ **15 Inch Driver** – Custom designed, heavy-duty, 15" low frequency driver provides deep bass.
- ⑧ **Bass Port** – Three precision tuned, low frequency port tubes extend the bass response.
- ⑨ **Steel Grill** – Durable steel grill provides protection for, and easy access to low frequency driver.

dB500a Layout

dB500a Rear Panel Layout

dB500a REAR PANEL

- ① **MIC LEVEL** – Used to adjust the volume of the microphone input.
- ② **AMP / CLIP LED** - Dual color LED lights Green when amp is active, flashes Red when the amp is clipped or stays Red indicating the amplifier is in protect mode.
- ③ **LINE LEVEL** – Used to control the level of the line input.
- ④ **LOW FREQUENCY** - Controls the low band of the Channel Equalizer, +/- 12 dB at 100Hz.
- ⑤ **HIGH FREQUENCY** - Controls the high band of the Channel Equalizer, +/- 12 dB at 10kHz.
- ⑥ **LIMITER SWITCH** - Used to engage the dB500a's Optimax dynamics processing. A red LED will illuminate indicating the Optimax is on.
- ⑦ **OUTPUT SWITCH** - This switch is used to select the signal that is sent to the Line Output. When the switch is in the up position, the signal on the Line Output is exactly the same as the signal on the Input. When the switch is in the down position the Line Output carries the MIX of the Mic and Line Inputs, as well as the High and Low Equalizer and Low Filter.
- ⑧ **FILTER SWITCH** - When engaged, a Low-Cut filter is employed at 80Hz with a roll-off slope of 12 dB per octave.
- ⑨ **LINE INPUT CONNECTOR** - Combo XLR plus 1/4 inch Input for connecting balanced or unbalanced line level signals.
- ⑩ **HEAT SINK** - Convection cooling of the internal power amplifier via massive aluminum extrusion.
- ⑪ **POWER** – Switches on the dB500a's main power.
- ⑫ **AC POWER INLET** – Connect the supplied standard IEC AC power cable here.
- ⑬ **LINE OUTPUT** - Male XLR connector used to link multiple dB500a's.
- ⑭ **MIC INPUT CONNECTOR** - XLR Input for connecting low impedance microphones to the Low-Noise pre-amp and Phantom Power.
- ⑮ **PEAK LED**- Red LED illuminates when the Mic input receives a clipped signal.

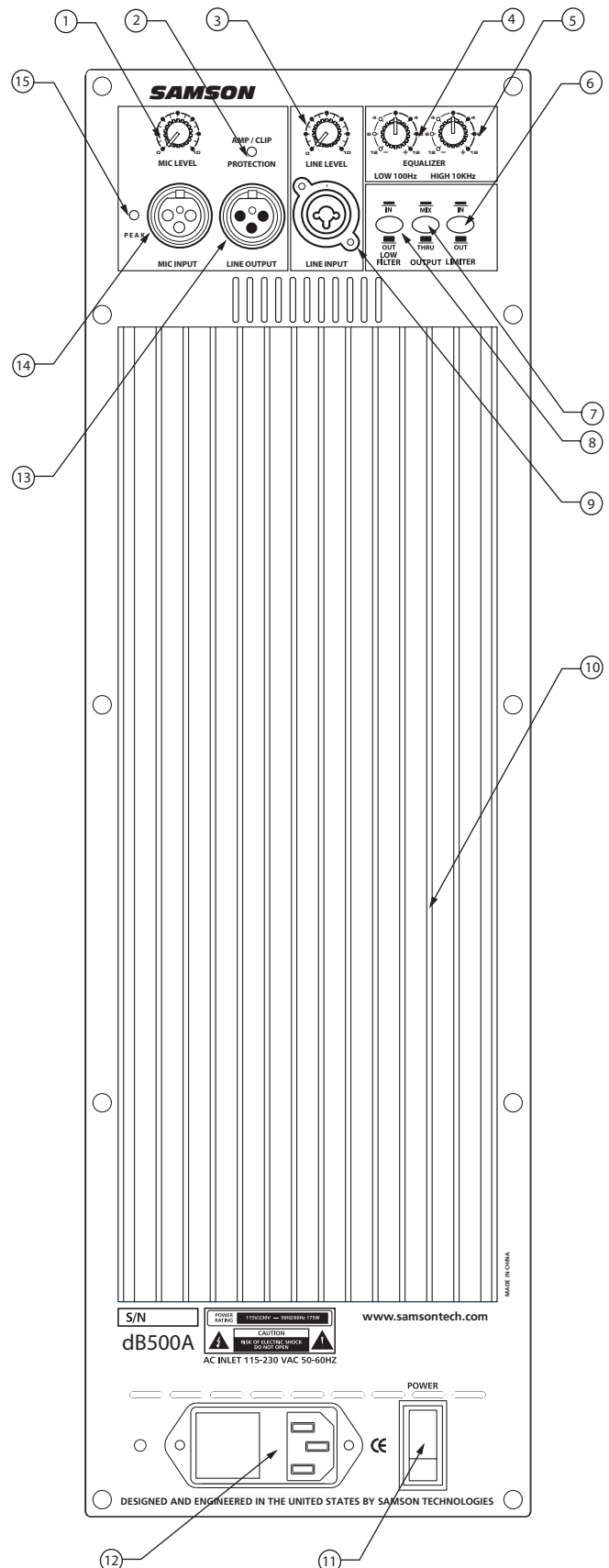

Quick Set-Up

In the following pages of this manual you will find a detailed explanation of all the dB500a's functions and controls, but if you just want to get started quickly you can follow the steps below.

IMPORTANT NOTE: To ensure the cleanest and loudest possible output, and to protect your speaker system, we highly recommend pressing the LIMITER switch on.

Using a Microphone

- Be sure that the dB500a's Power switch is set to the off position.
- Turn the LINE and MIC LEVEL controls fully counterclockwise to the off position.
- Connect the power cable to an AC socket.
- Using a standard XLR cable, plug a microphone into the dB500a's MIC INPUT.
- Switch the dB500a's Power switch to the ON position.
- While speaking into the microphone, slowly raise the MIC LEVEL control until you have reached the desired level.

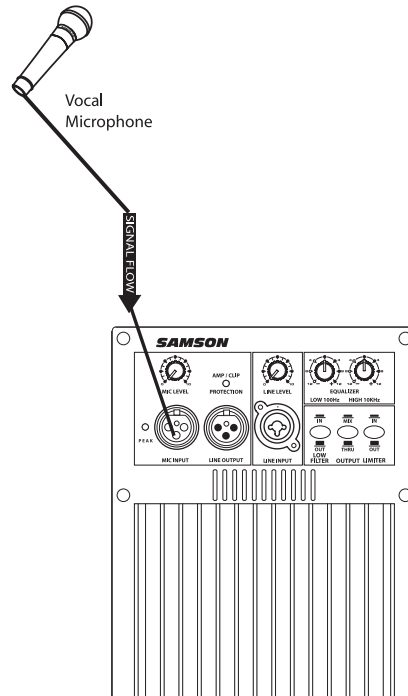

Using a Line Level Signal

- Be sure that the dB500a's Power switch is set to the off position.
- Turn the LINE and MIC LEVEL controls fully counterclockwise to the off position.
- Connect the power cable to an AC socket.
- Using a standard XLR or 1/4 inch cable, connect a line level signal from a mixer or keyboard into the dB500a's LINE INPUT.
- Switch the dB500a's Power switch to the ON position.
- Now, run an audio signal from your mixer (like some music from a CD) while slowly raising the dB500a's LINE LEVEL control until you have reached the desired level.

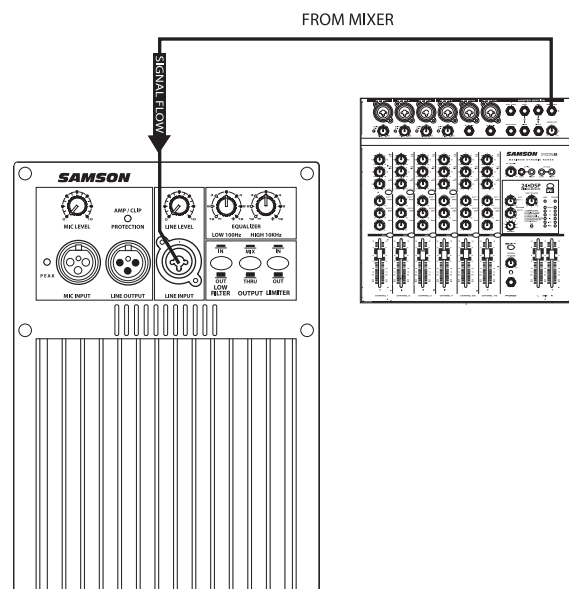

Positioning the dB500a

Microphone Positioning - How to Reduce Feedback

Feedback is the annoying howling and squealing that is heard when the microphone gets too close to the speaker and the volume is high. You get feedback when the microphone picks up the amplified signal from the speaker, and then amplifies through the speaker again, and then picks it up again, and so on and so on. In general, it is always recommended that any LIVE mic (a mic that's on) is positioned behind the speaker enclosures. This will give you the best level from your system before feedback. One possible exception is when you are adjusting the sounds of the microphones, since you want to listen in front of the speaker to hear properly. To do this, lower your mixers MAIN VOLUME while setting the EQ and effect from in front of the speakers. Once you have the sound you like, move the microphones to behind the speakers and raise the Main volume.

Speaker Placement

Whenever possible, it is a good idea to raise the speakers above the heads of the listening audience. The dB500a enclosures feature standard 1 3/8" pole mount receptacles, which are compatible with speaker stands from a variety of manufacturers. In a smaller setting like a school cafeteria, library, or a mall kiosk, you can also use the dB500a in one of the tilt back monitor positions, which will improve the projection of the speakers and may eliminate the need for speaker stands.

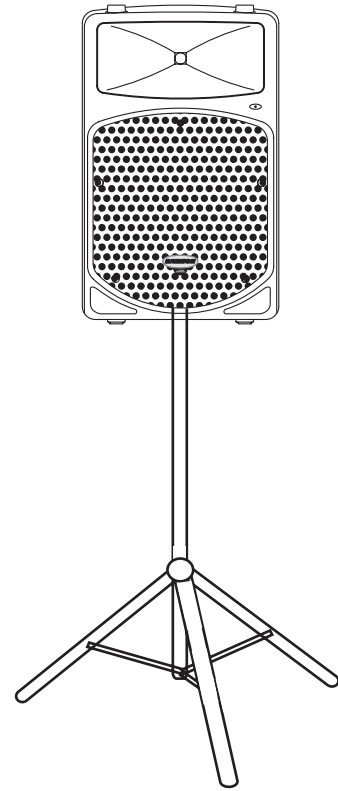

Using the dB500a as a Floor Monitor

The dB500a is an ideal solution for stage monitoring and thanks to its unique design, two wedge monitor positions are possible. When placed on its side with the high frequency horn facing to the left of the enclosure, the dB500a is tilted at a fifteen degree angle, optimizing performance when used on a large stage. When placed on its side with the high frequency horn facing to the right of the enclosure, the dB500a is tilted at a thirty degree angle optimizing performance when used on smaller stages. In a large stage monitor system, several dB500a's can be daisy-chained together using the Line Output. In many instances (when using the dB500a as a monitor system) you may choose to use an external equalizer like the Samson S Curve 131 to increase the volume and reduce the chance of feedback. In this case be sure to set the HIGH and LOW EQ to the 12:00 or flat position.

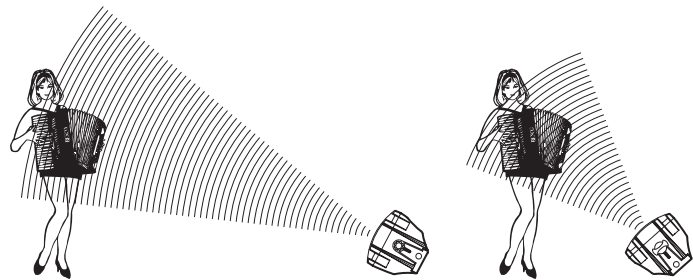

FAR FIELD

NEAR FIELD

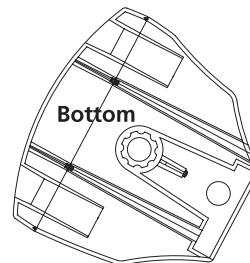

STAGE MONITOR POSITION
15 DEGREES

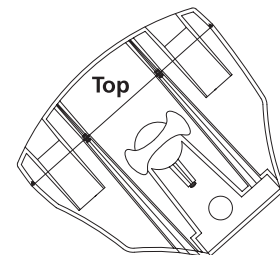

STAGE MONITOR POSITION
30 DEGREES

Operating the dB500a

Controls and Functions

The following section details each part of the dB500a's INPUT section including the MIC and LINE inputs, the two-band EQ, as well as the MIC and LINE LEVEL controls.

1 MIC LEVEL

The dB500a's MIC LEVEL controls the overall level of the microphone input. The MIC LEVEL control features an audio taper. Raise the MIC Level to adjust the volume of the microphone connected to the MIC input.

NOTE: Be sure to keep the MIC LEVEL control all the way off if there is no microphone connected.

2 PEAK LED

The PEAK LED will illuminate RED when the dB500a's mic input is receiving a clipped signal. If the PEAK LED lights up, lower the MIC LEVEL control. Once the PEAK LED goes off, raise the level controls back up until just before the PEAK LED lights.

3 DYNAMIC PROTECTION

The AMP / CLIP LED is a dual color LED used to monitor the output of the dB500a's internal power amplifiers. When the unit is first powered on, the AMP / CLIP LED will light red (indicating the output relay is open). After the soft-start circuitry activates and the output relay closes, the AMP / CLIP will change to bright green indicating the unit is ready for operation. The LED will flash red on signal power peaks, while the green LED is still on. If there is a failure condition such as DC on the output, the output relay opens and the LED will switch to solid red, indicating a fault. If this happens, contact your authorized Samson Audio Service Center.

4 LINE LEVEL

The dB500a's LINE LEVEL controls the overall level of the LINE input and features an audio taper. Raise the LINE Level to adjust the volume of the signal connected to the LINE input.

Using the Equalizer Section

The dB500a input channels feature a 2-band equalizer allowing you to adjust the high and low frequencies independently. The channel's frequency response is flat when the knobs are in the "12:00" position.

5 LOW

Rotating the LOW knob towards the right will boost the bass frequencies at 100Hz by 12dB, and rotating it towards the left will cut the bass frequencies at 100Hz by 12dB.

6 HIGH

Rotating the HIGH knob towards the right will boost the treble frequencies at 10kHz by 12dB, and rotating it towards the left will cut the treble frequencies at 10kHz by 12dB.

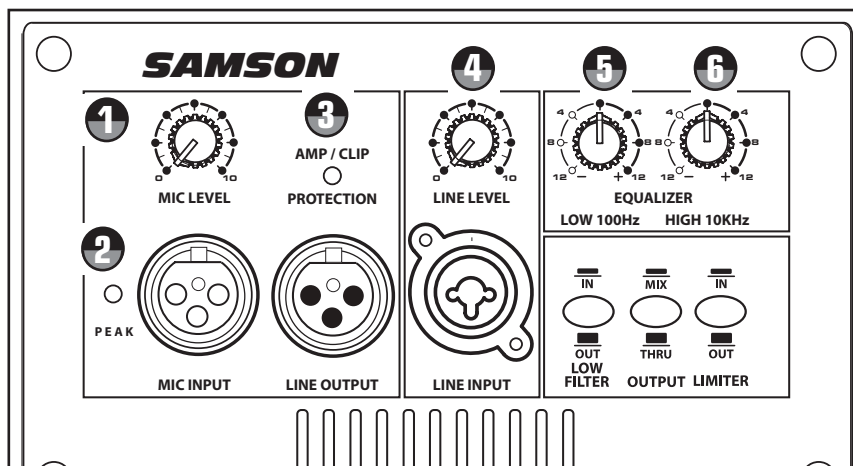

Operating the dB500a

Controls and Functions - continued

7 LOW FILTER

The dB500a also incorporates a Low-cut FILTER which when engaged will roll off the low frequency response of the cabinet beginning at 80Hz. The low cut FILTER is two pole, which means that the low frequency roll off will gradually cut more and more of the low frequencies (12dB per octave). When you press the FILTER switch in, the green LED will illuminate indicating that the Low-cut FILTER is engaged.

8 OUTPUT SWITCH

The Output switch is used to select the signal that is sent to the Line Output. You can have either a parallel output directly from the Line input, or a mixed signal including the Mic and line inputs plus the EQ and limiter. When the switch is in the up position, the signal on the Line Output is exactly the same as the signal on the Line Input. When the switch is in the down position the Line Output carries the MIX of the Mic and Line Inputs. If the Level controls, High and Low Equalizer and Filter are used, they will also effect the signal sent to the Line Output.

9 Optimax LIMITER

In order to keep the sound loud and clean, the dB500a incorporates Optimax multi-band Limiting. The Optimax Limiter divides the frequency range into separate parts so they can independently react to the limiting circuit. This ensures that the high energy for the low frequency of a bass drum doesn't cause the vocals to be over compressed. When you press the LIMITER switch in, the red LED will illuminate indicating that the Optimax dynamics processing is engaged.

IMPORTANT NOTE: Unless you are using an external limiter, it is highly recommended that the LIMITER switch be engaged at all times. This will ensure the cleanest possible output, and will protect your speaker system when it accidentally receives a clipped signal from your mixer.

Input and Output Connectors

10 MIC XLR Input

The dB500a's microphone input accepts a standard low impedance (150-600 Ohms) input and the connection is made via a standard female XLR connector. The microphone input features a high quality, discrete transistor pre-amp providing transparency and extended dynamic range. The MIC input can work simultaneously with the LINE input so it is possible to use a microphone while playing alone with a keyboard that is plugged into the dB500a's LINE input. You can control the microphone input by using the MIC LEVEL control as described in the section below.

11 LINE OUTPUT

You can run several monitors by using the LINE OUTPUT to daisy-chain one dB500a to another. The LINE OUTPUT is a balanced output that, depending on the position of the OUTPUT switch, will have either a direct parallel output of the Line input, or the Mix of the Line and Mic input. For more information on the Output switch, see section 8 above. For more information on cables and wiring, see page 14 of this manual for a detailed wiring diagrams.

12 LINE Combo Balanced Input

For added convenience, the dB500a employs a Combo connector that accepts a standard XLR mic cable for balanced line level signals, or a standard 1/4" instrument cable for either balanced (TRS – TIP/RING/SLEEVE) or unbalanced (TS – TIP/SLEEVE) line level signals. The LINE input can work simultaneously with the Mic input so it is possible to use a microphone while playing alone with a keyboard that is plugged into the dB500a's LINE input. You can control the LINE input by using the LINE LEVEL control as described in the previous page. For more information on cable and wiring, see page 14 of this manual for a detailed wiring diagrams

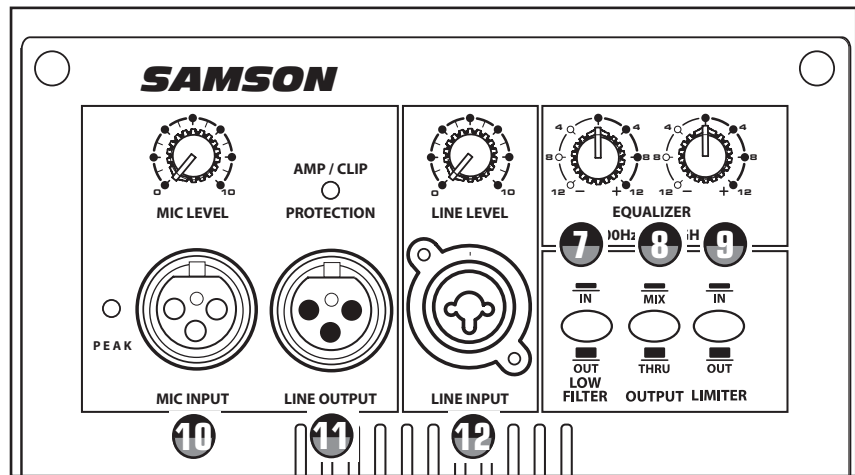

Setting Up Your dB500a System

Using Speaker Stands

The dB500a enclosure features a standard 1 3/8", pole mount receptacle, which is compatible with speaker stands from a variety of manufacturers. Before installing the dB500a on a speaker stand, loosen the thumbscrew located on the bottom of the rear side of the enclosure. Once installed on the stand, be sure to tighten the thumbscrew to hold the speaker in place. Be careful not to over tighten the thumbscrew to avoid stripping the threads.

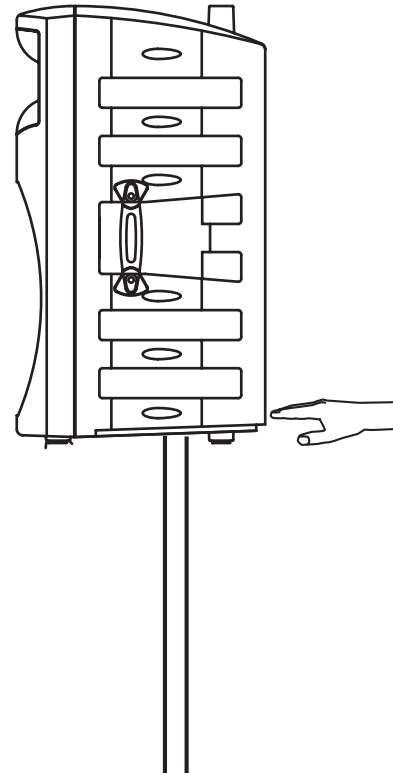

Stacking the dB500a

The dB500a enclosure incorporates gender mating stack feet and bumpers that allows you to stack one dB500a on top of another. When stacking the dB500a's, be certain that the rubber feet from the top unit are securely fastened into the bottom unit's stacking bumpers.

NOTE: DO NOT STACK dB500a's OVER TWO (2) TALL.

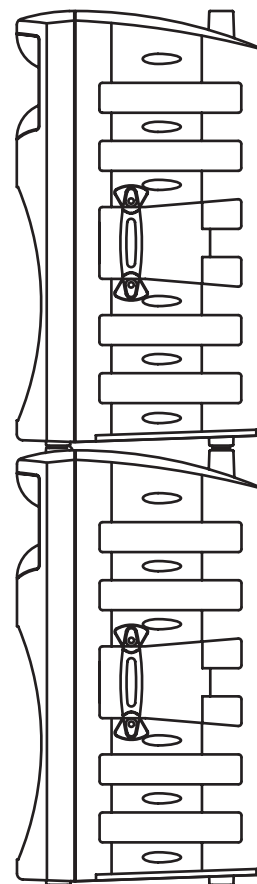

Setting Up Your dB500a System

Permanent Installation

The dB500a is logical solution for many fixed installations in live sound venues, discos, schools, houses of worship, convention centers and airport terminals to name a few. The enclosure is extremely versatile for installation as it can be hung in several different positions by using the ten Fly-points.

IMPORTANT NOTE: Hanging the dB500a is serious business and therefore licensed and insured professional sound contractors only should perform such an installation.

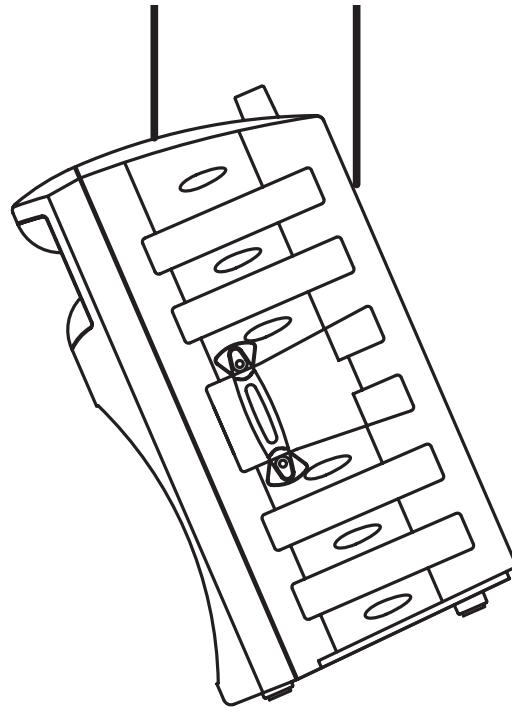

Using the Fly-points

The dB500a features ten fly-points located in pairs below each of the five carry handles. By removing the handles you will have access to the threaded inserts that are compatible with a variety of standard M8 hardware. The dB500a's ten fly points accept M8 rigging hardware like that available from ATM Flyware (www.atmflyware.com). M8-1.25, 16mm shoulder eyebolts (ATM Flyware part number, M8-1.25x16EYE) can be used for hanging the enclosure. When using the eyebolts, be sure to use a 1.3 mm (0.05") thick flat-washer for 8 mm bolts against the insert, and a 2.6mm (0.09") thick lock-washer for 8 mm bolts between the flat-washer and the eyebolt.

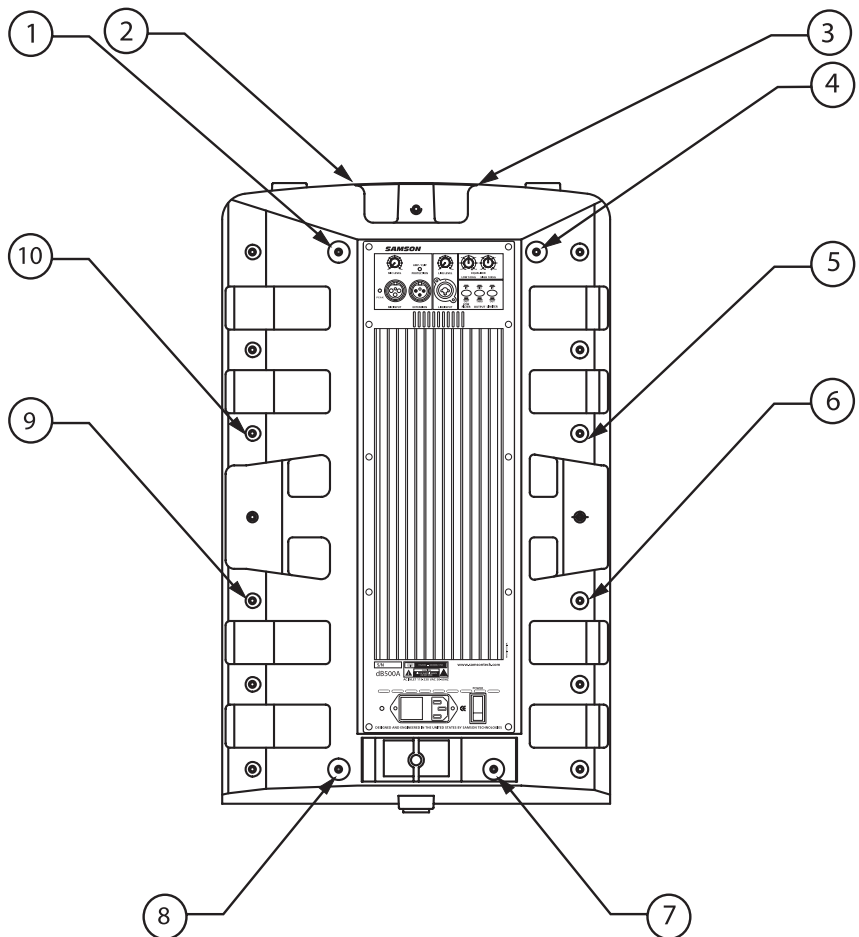

dB500a System Set

Compact Lounge PA for Two

This example shows a PA system set-up that can be used for a small club, at a ceremony or in a lounge, using a single dB500a for both a microphone and vocal. A separate signal is sent from the vocal microphone to the dB500a's Mic input, and from the keyboard to the dB500a's Line input. The individual Mic and Line level controls allow you to create a mix right on the dB500a. For further control, you can use the dB500a's two-band equalizer to boost or cut the highs and/or low frequencies adjusting the overall tonal contour of the system.

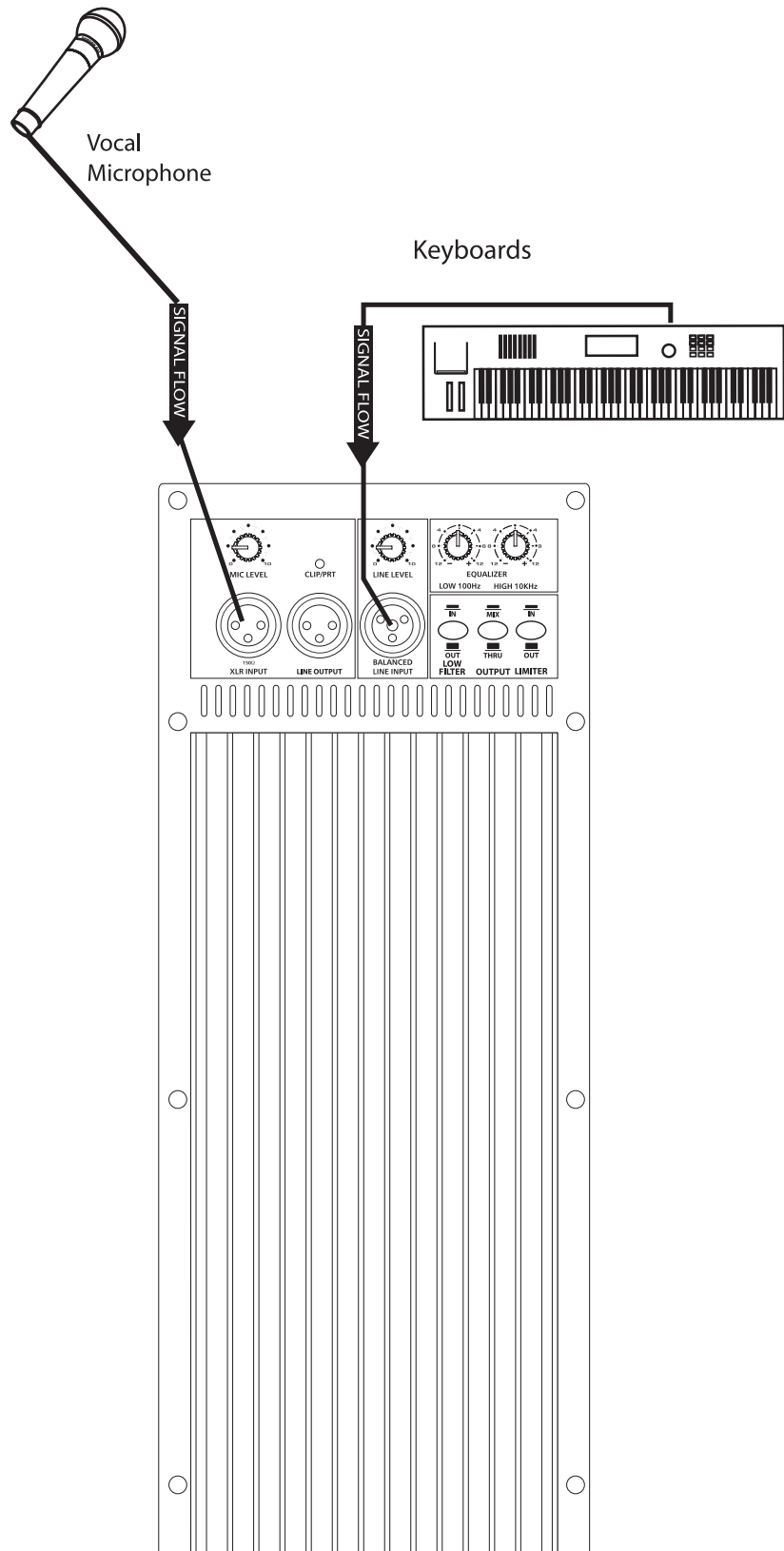

dB500a System Set Up

Live Band PA System With Monitors

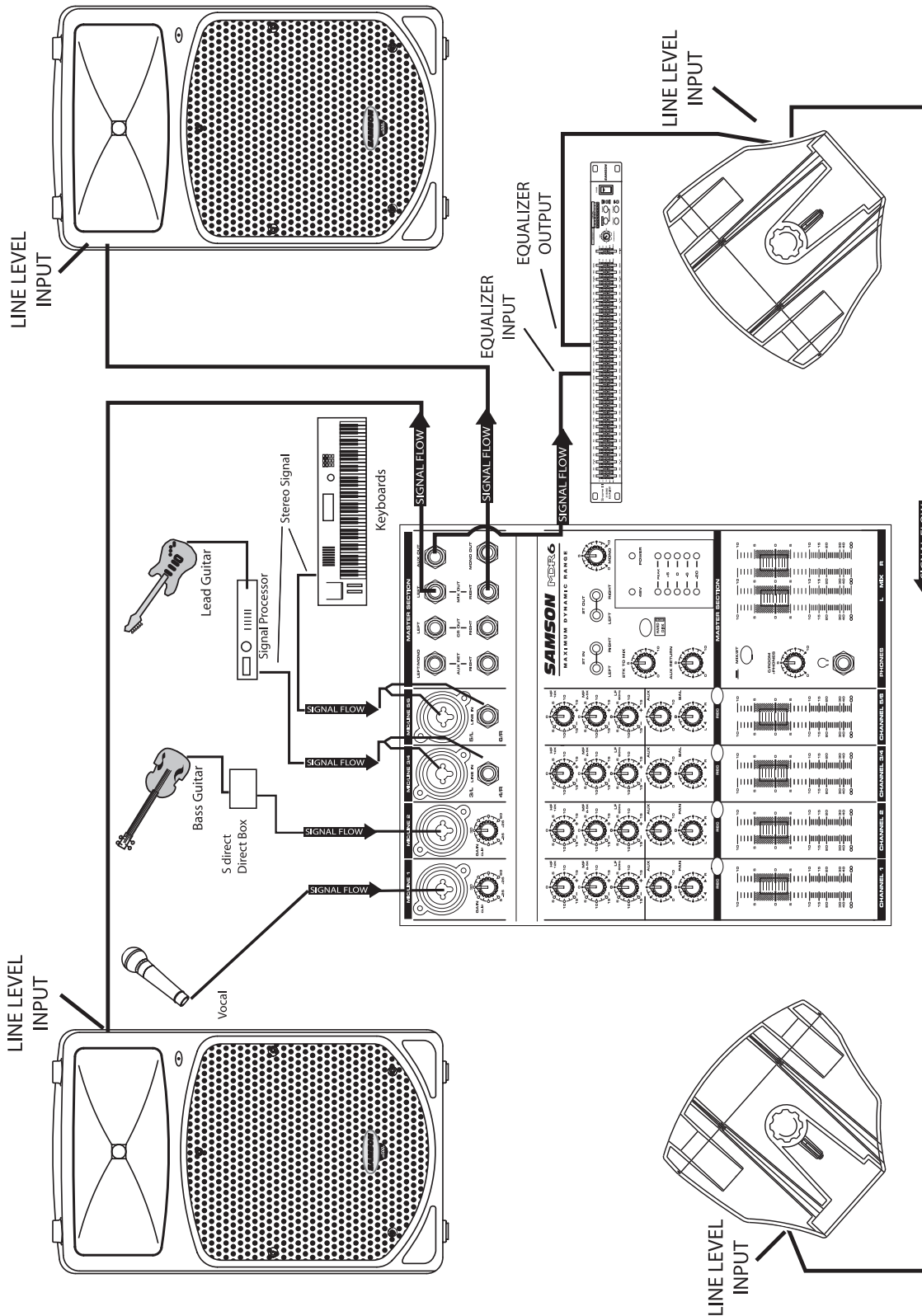

This example shows a typical PA system using mixer with a pair of dB500a's for the main left and right mix. A separate signal from the mixer's AUX/MONITOR bus is sent to two additional dB500a's placed in the tilt-back, wedge positions for use as floor monitors. In order to increase the output of the monitor system, the use of an external graphic equalizer like one of the Samson "E" or "S curve" series is highly recommended.

dB500a Wiring Guide

CONNECTING THE dB500a

There are several ways to interface the dB500a to support a variety of applications. The dB500a features balanced inputs and outputs, so connecting balanced and unbalanced signals is possible.

Unbalanced 1/4" Connector

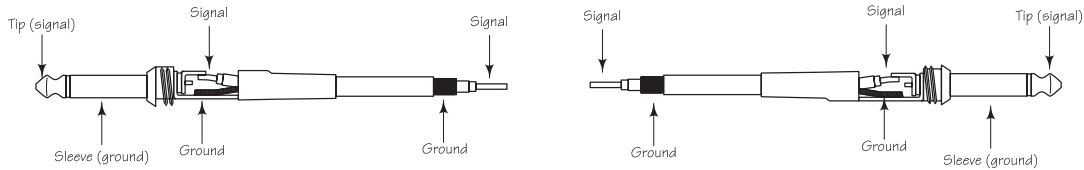

Balanced TRS 1/4" Connector

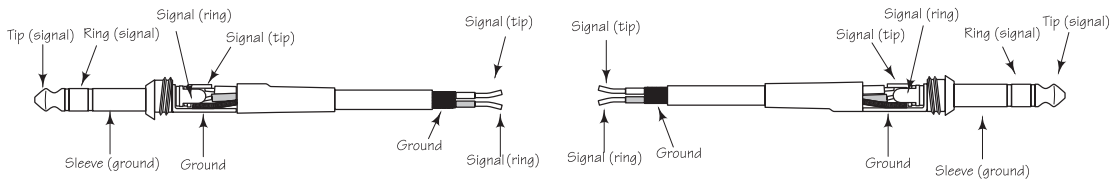

XLR to XLR Balanced

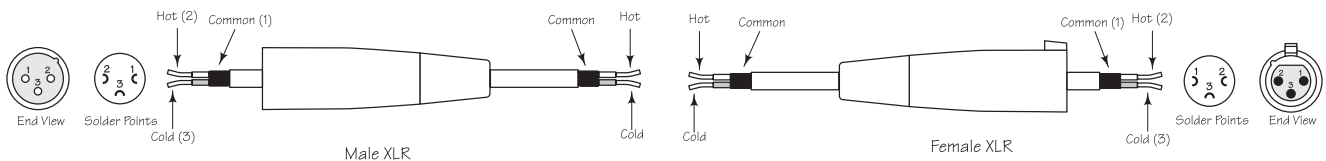

Unbalanced 1/4" Connector to RCA

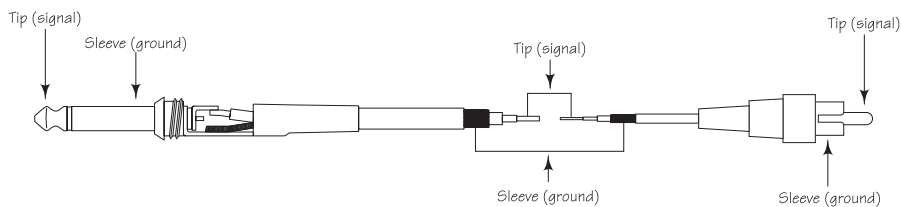

XLR to Balanced 1/4-Inch

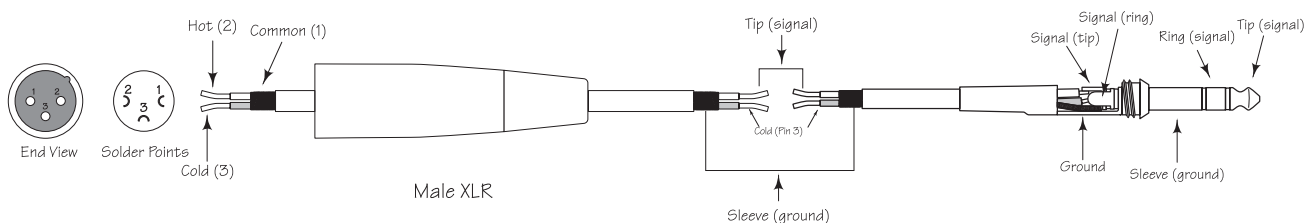

dB500a Specifications

Inputs

Microphone
Line

Balanced XLR
Balanced Combo XLR/Line

Outputs

Extension

Balanced XLR

Controls

Mic Level
Line Level
Low EQ
High-EQ
Low Filter Switch
Output Switch
Limiter Switch

Rotary
Rotary
Rotary Center Detent, +/-12dB @100Hz
Rotary Center Detent, +/-12dB @ 10kHz
Push Switch, High Pass (low-cut) 12dB per octave @80Hz
Push Switch, Selects Mix orThru for Line Output Connector
Push Switch, Optimax Multi-band dynamics - In/Out

Power Rating:

Low Frequency
High Frequency

400 Watt RMS
100 Watt RMS

Frequency Response:

60 Hz – 24 kHz ± 3 dB

Crossover Frequency:

2.3 kHz, 3 pole (24 dB Per Octave)

LF Driver:

15" heavy-duty bass transducer,
2.5" voice coil (Kapton Former)
50 oz. barium ferrite magnet

HF Driver:

1.75" titanium compression driver,
edge-wound copper voice coil,
75 oz. magnet structure

Mounting:

Stand
Fly Points
Stacking

Large, gender mating stacking
bumpers

Integral 1 3/8" Pole Mount Receptacle,
10

Weight:

61lbs.
(27.7kg.)

Dimensions:

30" (h) x 19" (w) x 18" (d)
762mm (h) x 483mm (w) x 457mm (d)

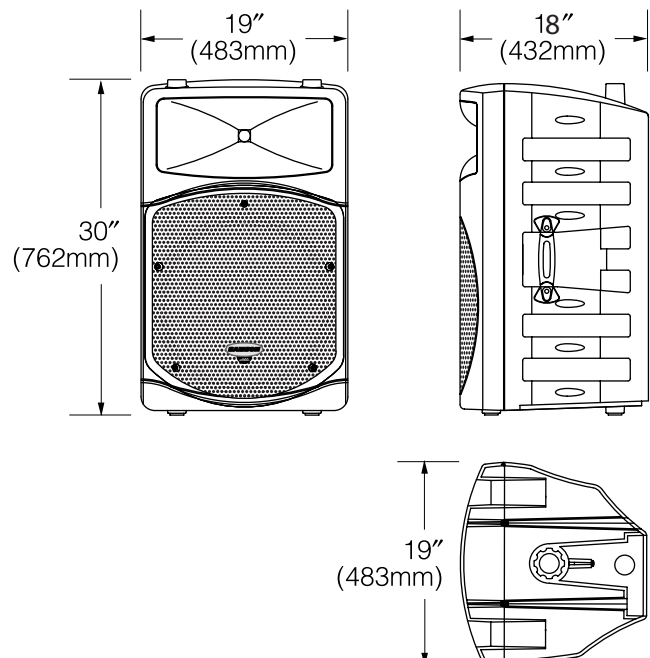

Notes

Samson Technologies Corp.
575 Underhill Blvd.
P.O. Box 9031
Syosset, NY 11791-9031
Phone: 1-800-3-SAMSON (1-800-372-6766)
Fax: 516-364-3888
www.samsontech.com

Free Manuals Download Website

<http://myh66.com>

<http://usermanuals.us>

<http://www.somanuals.com>

<http://www.4manuals.cc>

<http://www.manual-lib.com>

<http://www.404manual.com>

<http://www.luxmanual.com>

<http://aubethermostatmanual.com>

Golf course search by state

<http://golfingnear.com>

Email search by domain

<http://emailbydomain.com>

Auto manuals search

<http://auto.somanuals.com>

TV manuals search

<http://tv.somanuals.com>