

SUB 120

R E F E R E N C E
SUBWOOFER

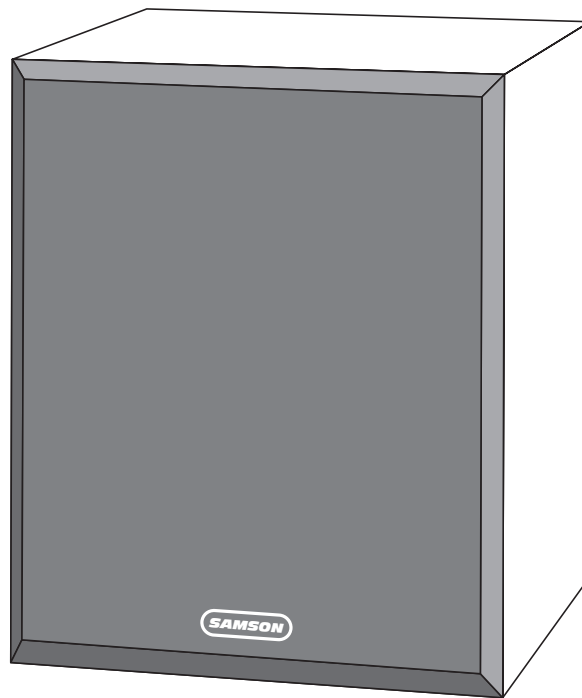

OWNERS MANUAL

SAMSON[®]

Safety Instructions

Caution: To reduce the hazard of electrical shock, do not remove cover or back.

No user serviceable parts inside. Please refer all servicing to qualified personnel.



WARNING: To reduce the risk of fire or electric shock, do not expose this unit to rain or moisture.

The lightning flash with an arrowhead symbol within an equilateral triangle, is intended to alert the user to the presence of uninsulated "dangerous voltage" within the products enclosure that may be of sufficient magnitude to constitute a risk of electric shock to persons.

The exclamation point within an equilateral triangle is intended to alert the user to the presence of important operating and maintenance (servicing) instructions in the literature accompanying the product.

Important Safety Instructions

1. Please read all instructions before operating the unit.
2. Keep these instructions for future reference.
3. Please heed all safety warnings.
4. Follow manufacturers instructions.
5. Do not use this unit near water or moisture.
6. Clean only with a damp cloth.
7. Do not block any of the ventilation openings. Install in accordance with the manufacturers instructions.
8. Do not install near any heat sources such as radiators, heat registers, stoves, or other apparatus (including amplifiers) that produce heat.
9. Do not defeat the safety purpose of the polarized or grounding-type plug. A polarized plug has two blades with one wider than the other. A grounding type plug has two blades and a third grounding prong. The wide blade or third prong is provided for your safety. When the provided plug does not fit your outlet, consult an electrician for replacement of the obsolete outlet.
10. Protect the power cord from being walked on and pinched particularly at plugs, convenience receptacles and at the point at which they exit from the unit.
11. Unplug this unit during lightning storms or when unused for long periods of time.
12. Refer all servicing to qualified personnel. Servicing is required when the unit has been damaged in any way, such as power supply cord or plug damage, or if liquid has been spilled or objects have fallen into the unit, the unit has been exposed to rain or moisture, does not operate normally, or has been dropped.

Table of Contents

Introduction	3
SUB120 Features	4
SUB120 Layout	
Front View Layout	5
Rear Panel Layout	6
Setting Up the SUB120	
Configuring Your Speaker system	7
Operating the SUB120	7-8
Connecting the Sub120	
Using the SUB120 with the Samson DMS80 Monitor System	9-10
Mono Sub With Passive Satellites Using Speaker Inputs	11
Mono Sub With Passive Satellites Using Line Inputs	12
Mono Sub With Active Satellites	13
Stereo Sub With Passive Satellites	14
SUB120 Wiring Guide	15
Specifications	16

Copyright 2001, Samson Technologies Corp.

Printed March, 2001

Samson Technologies Corp.
575 Underhill Blvd.
P.O. Box 9031
Syosset, NY 11791-9031
Phone: 1-800-3-SAMSON (1-800-372-6766)
Fax: 516-364-3888
www.samsontech.com

Introduction

Thank you for purchasing the Samson SUB 120 Reference Subwoofer. The Samson SUB 120 is a self powered 120 Watt subwoofer featuring a 10", 25mm excursion transducer with Butyl surround. The SUB 120 is a perfect add-on to your Samson DMS80 monitor system, or for any near field monitor system where extended low end is desired.

In these pages, you'll find a detailed description of the features of the SUB120 subwoofer, as well as a guided tour through its control panel, step-by-step instructions for its setup and use, and full specifications. You'll also find a warranty card enclosed—please don't forget to fill it out and mail it in so that you can receive online technical support and so we can send you updated information about these and other Samson products in the future.

With proper care and adequate air circulation, your SUB120 will operate trouble free for many years. We recommend you record your serial number in the space provided below for future reference.

Serial number: _____

Date of purchase: _____

Should your unit ever require servicing, a Return Authorization number (RA) must be obtained before shipping your unit to Samson. Without this number, the unit will not be accepted. Please call Samson at 1-800-3SAMSON (1-800-372-6766) for a Return Authorization number prior to shipping your unit. Please retain the original packing materials and if possible, return the unit in the original carton and packing materials.

SUB 120 Features

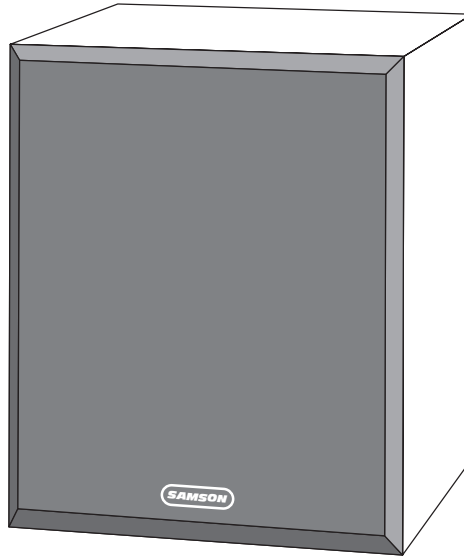

The Samson SUB 120. Here are some of its main features:

- Heavy-duty, 10" Long Excursion (25mm) Transducer With Butyl Surround
- 120 Watt Power Amplifier
- Tuned Port Enclosure
- High Pass Outputs for Satellite Speakers
- Variable Crossover 40 - 180 Hz
- Phase Switch
- Line Inputs and Outputs on RCA jacks
- Speaker Terminal Inputs and Outputs
- Auto Sleep Switch
- Volume Control
- Black Satin Finish
- Three-year extended warranty

Front View Layout

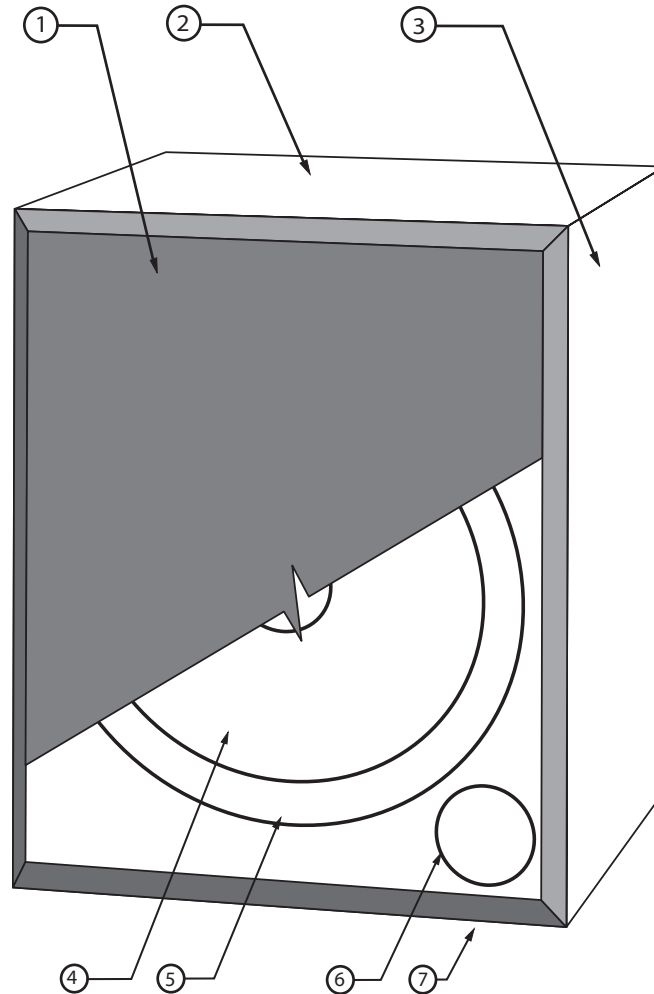

- ① **GRILL SCREEN** - Tough cloth and wood frame construction provides durable and stylish protection for the speaker.
- ② **ENCLOSURE** - Rigid MDF Construction.
- ③ **FINISH** - Sleek black oak finish.
- ④ **TRANSDUCER** - Heavy Duty 10," long excursion (25mm) extended range low frequency transducer .
- ⑤ **BUTYL SURROUND** - Provides maximum excursion while maintaining tight bass response.
- ⑥ **TUNED PORT** - Quiet port design offering linear extended low frequency response. (Rear of unit.)
- ⑦ **NON-SKID FEET** - Large rubber feet keep enclosure in place even at high sound pressure levels.

SUB 120 Layout

Rear Panel Layout

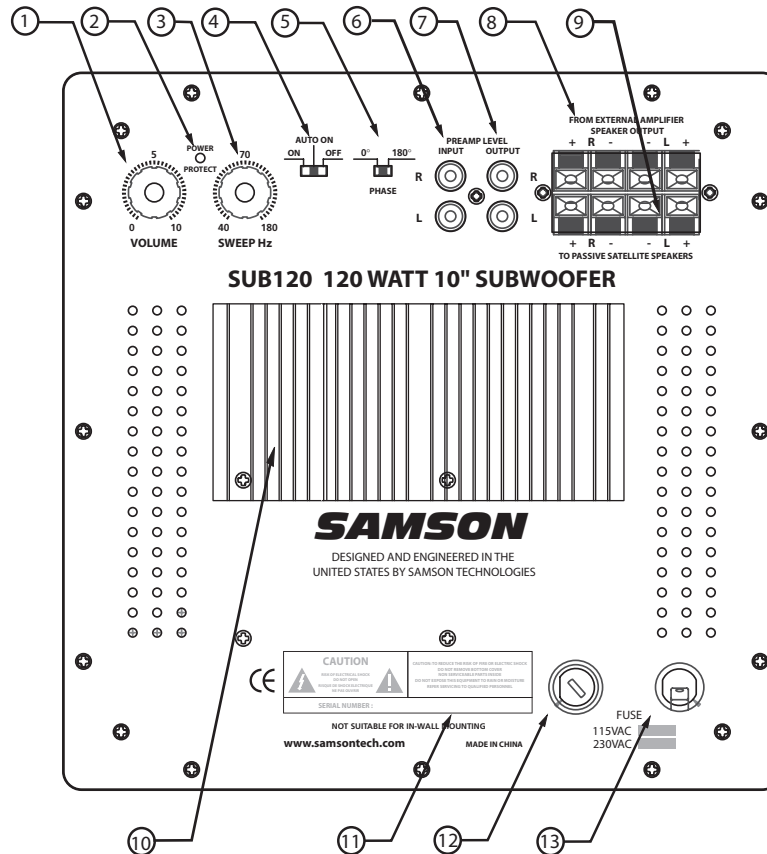

- | | |
|--|---|
| <p>① VOLUME - Controls the amount of output level.</p> <p>② SWEEP HZ - Adjusts the low frequency end range of the High-Pass outputs.</p> <p>③ POWER/PROTECT LED - Indicates power is on and if amplifier is in Protect mode.</p> <p>④ AUTO SLEEP SWITCH - When activated, Sleep Mode conserves power by automatically turning unit into standby mode after 10 minutes of non-use.</p> <p>⑤ PHASE SWITCH - Allows for 180 degrees out-of-phase operation.</p> <p>⑥ PREAMP LEVEL INPUT - Accepts Line Level input signals from mixer .</p> | <p>⑦ PREAMP LEVEL OUTPUT - Sends Low Level Output signal.</p> <p>⑧ SPEAKER LEVEL INPUT- Accepts full range signals from power amplifier.</p> <p>⑨ SPEAKER LEVEL OUTPUT- Sends full range signals to satellite speakers.</p> <p>⑩ HEAT SINK - Provides cooling of internal power amplifier.</p> <p>⑪ SERIAL NUMBER - Unit serial number is located here.</p> <p>⑫ FUSE - User accessible fuse.</p> <p>⑬ POWER CORD - Heavy duty power cord.</p> |
|--|---|

Setting up the SUB120

CONFIGURING YOUR SPEAKER SYSTEM

Before you start plugging in cables, you should take a minute and decide how you want to interface your new subwoofer. There are several ways you can interface the SUB120 and two specific categories should be considered. First, Stereo vs Mono operation, and second, whether High (powered) or Low (line) level inputs and outputs will be used.

Common Sub Operation

In most cases, a common sub (mono) bass operation is desired. This is true for several reasons, but mostly because low frequencies produced by a subwoofer tend to be non-directional. Since low frequency waves take so much space to actually develop, you can't tell if the sub-bass is coming from the left or right side. Unless of course you're in a very large room. Because of this phenomena, just about all sub-bass material is mixed in mono.

Stereo Sub Operation

Two SUB120's can be used in stereo in larger control rooms for increased low end. In addition, two SUB120's can be used in stereo, even in smaller control rooms, to help minimize standing waves. By using two subwoofers at lower power, you can achieve a more even response throughout the room.

Placing the SUB120

Because the low frequencies reproduced by the SUB120 are non-directional, you can position the unit almost anywhere. It is however, a good idea to keep the SUB 120 away from corners. Ideally the SUB120 should be positioned in the middle, and up close to, the wall you are facing in the mixing position.

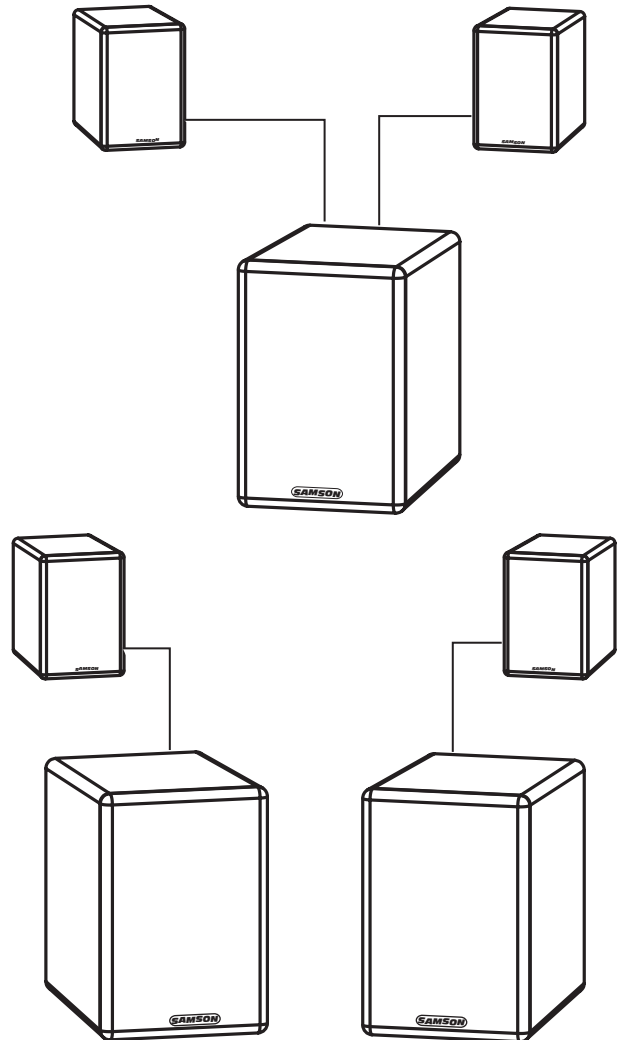

Operating the SUB120

SUB120 Control Panel

The SUB120's control panel provides the connections and user interface to the SUB120's internal electronic crossover and power amplifier section. The internal amplifier is a 120 Watt power amplifier capable of producing incredible bass output. The SUB120 employs an electronic crossover that adjusts the high frequency cutoff point for the subwoofer, and also, a high-pass output for your satellite speakers. You will achieve a tremendous benefit in sound quality by running your satellite speakers from the SUB120's High-Pass outputs. The reason for this is that when your satellite speaker receives the filtered output from the SUB120, it will no longer be looking at the frequency below the crossover point. Let's say your satellite speaker has a natural frequency roll-off at 70 Hz, and you are sending full range signal (as low as 20Hz) to the satellite amplifier and speaker. Even though the speaker can only reproduce 70Hz and up, the amplifier is still outputting 20-70Hz, which is wasted power and ultimately turns into heat. By using the SUB120's High-Pass output, the satellite amplifier and speaker never see the frequencies lower than what's set by the Sweep frequency. This means you'll have more power dedicated to

Operating the SUB120

SUB120 Control Panel - Continued

to the frequencies you want the satellites to reproduce, resulting in a much cleaner sound with more headroom.

1 Volume Control

The volume control is used to adjust the amount of level to the SUB120 subwoofer. In addition, the volume control will also control the output level of the high-pass outputs. Therefore, if you are using the SUB120 without using the high-pass outputs (for example, when the SUB120 is connected to an external crossover) the volume control adjusts the low frequency output of the SUB120. If you are using the SUB120's internal electronic crossover to run satellite speakers, then the volume control will adjust the overall system level.

2 Sweep Hz

The Sweep Hz control selects the upper range cutoff frequency of the SUB120's internal electronic crossover. The SUB120's crossover provides a 12dB per octave Linkwitz Riley filter curve. The Sweep adjusts the highest frequency that the SUB120 will reproduce, and at the same time, the high-pass outputs track the selected crossover frequency as the lower limit frequency to the satellite speakers.

3 Power/Protect LED

The POWER/PROTECT LED is a dual color LED which has three states; OFF, GREEN AND RED. The following chart shows the POWER/PROTECT LED and the different operating conditions it represents.

AUTO ON SWITCH	LED - OFF	LED - GREEN	LED - RED
ON	Not Applicable	SUB120 - ON	PROTECT
AUTO	SLEEP	SUB120 - ON	PROTECT
OFF	SUB120 - OFF	Not Applicable	Not Applicable

If the SUB120 receives a clipped signal for a long duration of time the unit will shut down and enter PROTECT mode. When the SUB120 is in Protect, you will see the POWER /PROTECT LED is lit up in red. If this happens simply turn the unit off, wait a minute and then re-power up the unit. The LED should return to a green color again indicating normal operation. At this point, readjust the level you're sending to the SUB120 so that the signal is not clipped and the unit will operate properly.

4 Auto On Switch

The AUTO ON switch is used to select the SUB120's power operating mode. When the switch is set to OFF the unit is not operational. When the AUTO ON switch is set to the ON position, the unit is always on. To engage the SUB120's SLEEP function, slide the AUTO ON switch to the AUTO position. In this mode, the SUB120 enters a stand-by, or "SLEEP" condition after no input signal is sensed for a period of approximately 10 minutes. The SUB120 will return to the normal operating mode as soon as it senses a signal present at the inputs.

5 Phase Switch

The SUB120 can be switched for inverted phase operation by setting the PHASE SWITCH to the 180° (degree) position. Experiment with this switch to provide the best blend between the subwoofer and satellite speakers.

6 The Ins and The Outs

The SUB120 features both line level and speaker level inputs and outputs so that connection with passive or active satellites is easy. The PREAMP LEVEL INPUTS simply pass the line level signal through to the PREAMP LEVEL OUTPUTS. You can use the line inputs and outputs to interface the SUB120 with active monitors. The SPEAKER LEVEL INPUTS can be connected from the speaker outputs of a power amplifier, and then the signal is sent from the SPEAKER OUTPUTS, which are high-passed, to passive satellite speakers. The following sections of this manual detail the set-ups for many typical configurations with both passive and active monitors. In addition, there is a detailed cable wiring diagram on page 15.

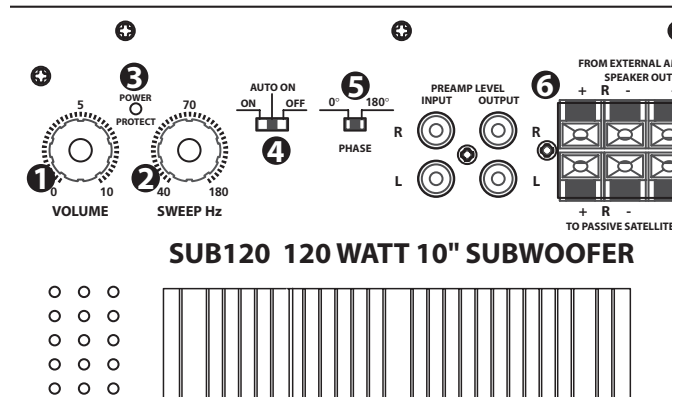

Connecting the SUB120

USING THE SUB120 WITH THE SAMSON DMS80 MONITOR SYSTEM

Using The DMS80's SUB OUT

The SUB120 is a great add on to your DMS monitor system providing extended low frequency output. There are several ways you can interface your new subwoofer to the DMS80, including using the DMS80's mono SUB OUT, or by using the DMS 80's LINE OUTs. The following examples outline the connections and operation for the SUB120 working with the DMS80 system.

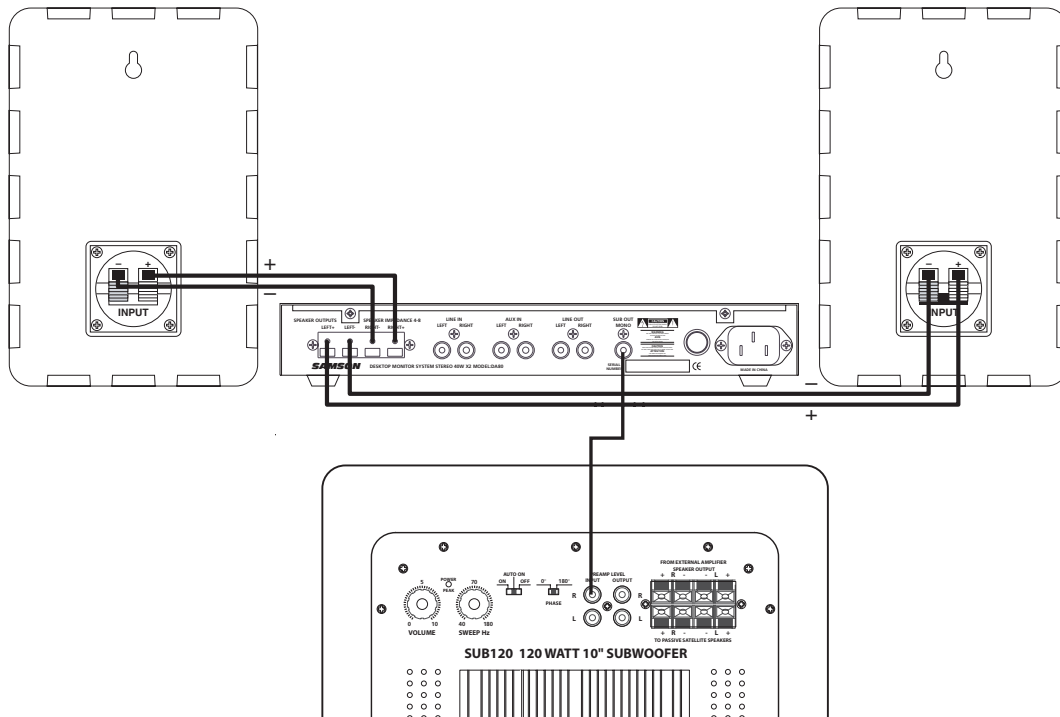

- Make the connections between your mixer and your DMS80 monitor system as described in the DMS80's users manual and make sure that you turn your mixer all the way down.
- * Connect the SUBWOOFER OUTPUT located on the rear panel of the DMS80 to the RIGHT PREAMP INPUT on the SUB120.
- Set the SUB120's Volume control to about 6, and since the DMS80's SUBWOOFER OUTPUT is High-passed at 100 Hz, set the SWEEP control to 180Hz.
- Now run some audio, like music on a CD, through your mixer and raise the output to the DMS80 monitor system to a comfortable listening level.
- Now slowly raise the SUBWOOFER LEVEL control located on the DMS80 front control panel and adjust the low frequency output to your taste. You can experiment with the balance between the SUB120 and the DMS satellite speakers by adjusting the SUBWOOFER LEVEL control. Once you find the balance you like, the SUB120 will track the satellites when you raise or lower your mixer's output.

Connecting the SUB120

USING THE SUB120 WITH THE SAMSON DMS80 MONITOR SYSTEM

Using The DMS80's LINE OUTs

The SUB120 can be connected to the DMS80's by using the LINE OUTS located on the DMS80's rear panel. When using the DMS80's LINE outputs you will utilize the SUB120 internal electronic crossover, which will allow you to experiment and fine-tune your monitor system. Follow the diagram and instructions below to interface your new subwoofer.

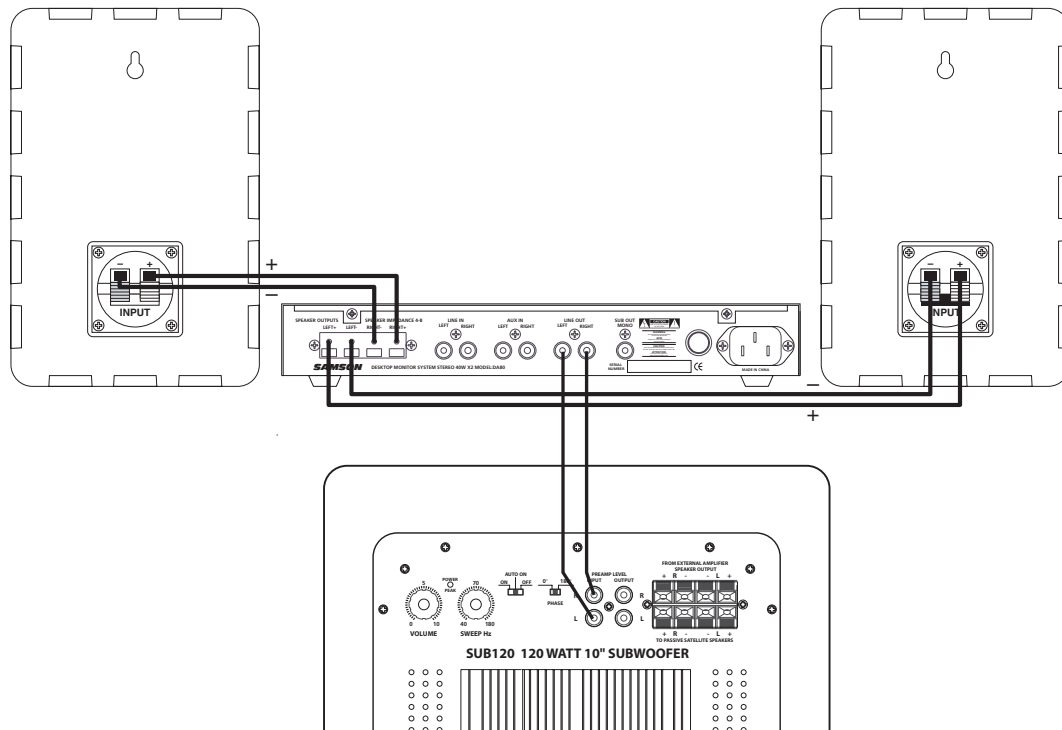

- Make the connections between your mixer and your DMS80 monitor system as described in the DMS80's users manual and make sure that you turn your mixer all the way down.
- * Connect the RIGHT and LEFT LINE OUTPUTS located on the rear panel of the DMS80 to the RIGHT and LEFT PREAMP INPUTS on the SUB120.
- Turn the SUB120's Volume all the way off, and set the SWEEP control to 100Hz.
- Now run some audio, like music on a CD, through your mixer and raise the output to the DMS80 monitor system to a comfortable listening level.
- Now, slowly raise the SUB120's LEVEL control and adjust the low frequency output to your taste. You can experiment by listening to the difference when adjusting the crossover point with the SWEEP control. Also, listen as you adjust the balance between the SUB120 and the DMS satellite speakers by changing the SUB120's LEVEL control. Once you find the balance you like, the SUB120 will track the satellites when you raise or lower your mixer's output.

Connecting the SUB120

Mono Sub With Passive Satellites Using Speaker Inputs

The SUB120 is a perfect addition to any near-field monitoring system where enhanced low-end is desired. Below is a typical system set using the SUB120 with a mixer, amplifier and a pair of passive satellite speakers. In this mode, the signal sent to the satellite is high-passed at 100Hz. The SUB120's input and outputs utilize industry standard speaker connectors. Follow the steps below the diagram to set up your system.

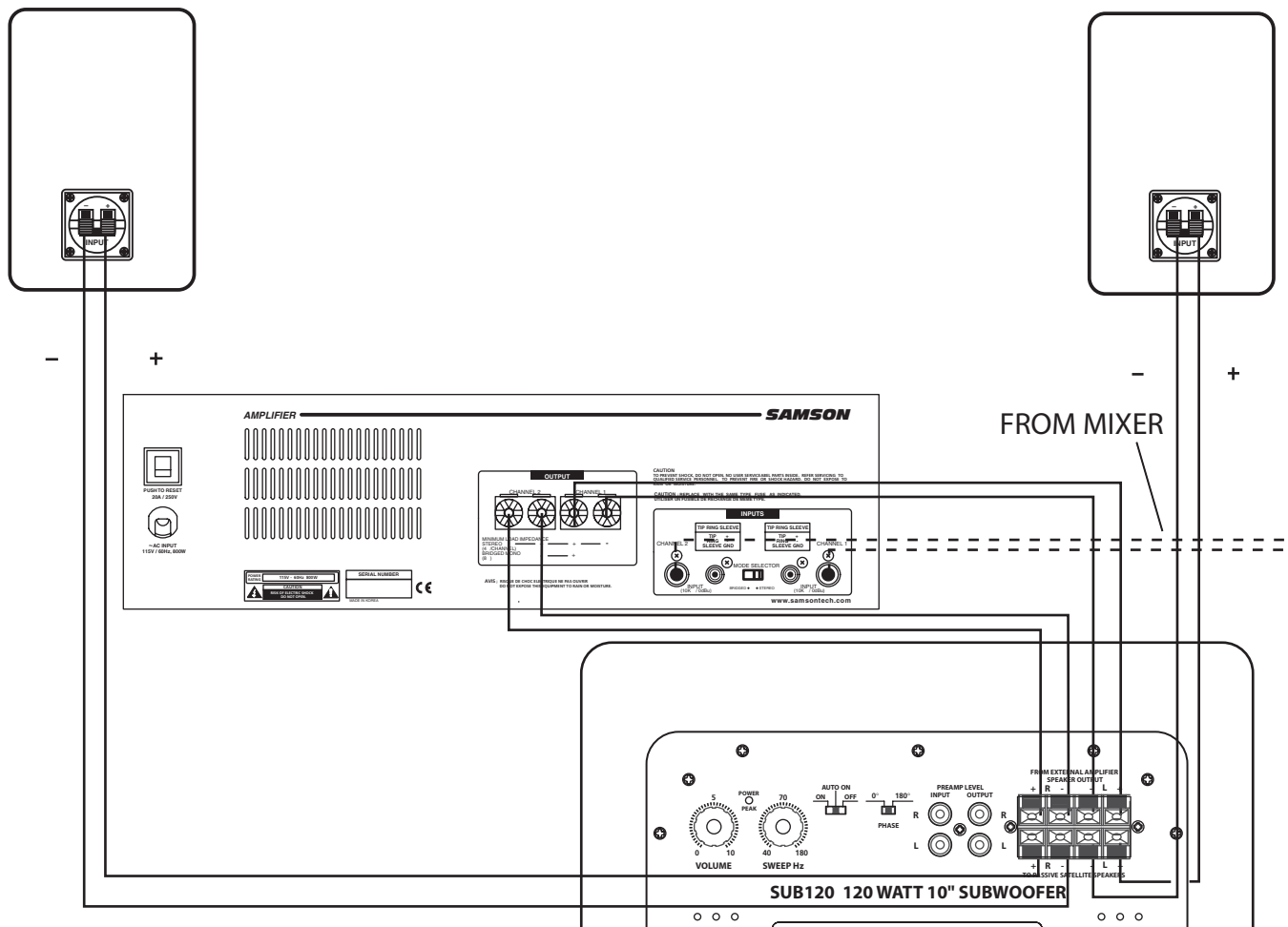

- Lower your mixer's master outputs to all the way off.
- Connect the mixer's left output to the left input of your power amp and the mixer's right output to the right input of your power amp. Now, using standard speaker cable, connect the power amp's left speaker output to the SUB120's LEFT SPEAKER INPUT and the power amp's right speaker output to the SUB120's RIGHT SPEAKER INPUT. To complete the connections, run a cable from the SUB120's LEFT SPEAKER OUTPUT to the left satellite and from the RIGHT SPEAKER OUTPUT to the right satellite speaker.
- Now adjust the SWEEP control to the desired frequency. Consult your studio monitors owner's manual for a recommended crossover point. You can also use your ears by adjusting the SWEEP control to the frequency that sounds good to you. A good place to start is about 70 Hz.
- Now set the level of your power amp up to the normal operating level. Run an audio signal (like some music from a CD) through your mixer and raise the level to a comfortable listening level. Now slowly raise the SUB120 Volume control and listen to the low frequency output. Adjust the SUB120 to the level of low frequency output that you like. Now, when you raise and lower your mixer's output, the SUB120 and satellites will track at the same relative volume.

Connecting the SUB120

Mono Sub With Passive Satellites Using Line Inputs

The SUB120 can be operated using line level inputs and outputs. When using the SUB120 at line level, the full range signal is maintained at the outputs. Below is a typical system set up using the SUB120 with a mixer, stereo power amp and a pair of passive satellite loudspeakers. The SUB120's inputs and outputs utilize industry standard RCA connectors. For a detailed wiring diagram, see the section SUB120 Connections on page 17. Follow the steps below the diagram to set up your system.

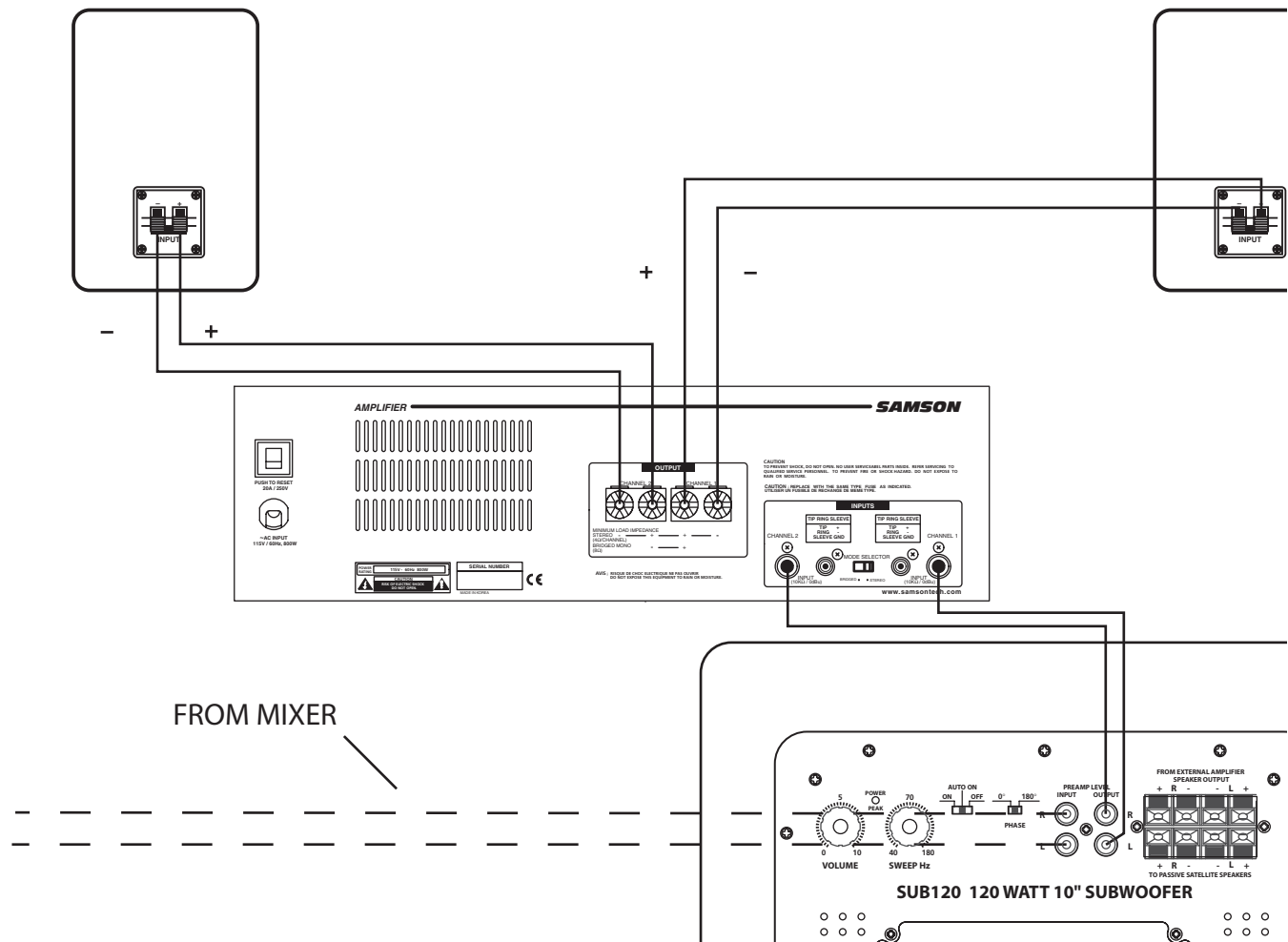

- Lower your mixer's master outputs to all the way off.
- Connect the mixer's left output to the SUB120's LEFT PREAMP LEVEL INPUT and the mixer's right output to the SUB120's RIGHT PREAMP LEVEL INPUT. Now connect the SUB120's LEFT PREAMP LEVEL OUTPUT to the left side input of the power amp, and the SUB120's RIGHT PREAMP LEVEL OUTPUT to the right side input of the power amp. Connect a speaker wire from the left output of your power amp to your left satellite, and then, connect a speaker wire from the right output of your power amp to your right satellite.
- Now adjust the SWEEP control to the desired frequency. Consult your studio monitors owner's manual for a recommended crossover point. You can also use your ears by adjusting the SWEEP control to the frequency that sounds good to you. A good place to start is about 70 Hz.
- Now set the level of your power amp up to the normal operating level. Run an audio signal (like some music from a CD) through your mixer and raise the level to a comfortable listening level. Now slowly raise the SUB120 volume control and listen to the low frequency output. Adjust the SUB120 to the level of low frequency output that you like. Now, when you raise and lower your mixer's output, the SUB120 and satellites will track at the same relative volume.

Connecting the SUB120

Mono Sub With Active Satellites

If you have active studio monitors, installation is easy through the SUB120's LINE LEVEL inputs and outputs. Below is a typical system set up using the SUB120 with a mixer and a pair of active satellite speakers. The SUB120's input and outputs utilize industry standard RCA connectors. For a detailed wiring diagram, see the section SUB120 Connections on page 15. Follow the steps below the diagram to set up your system.

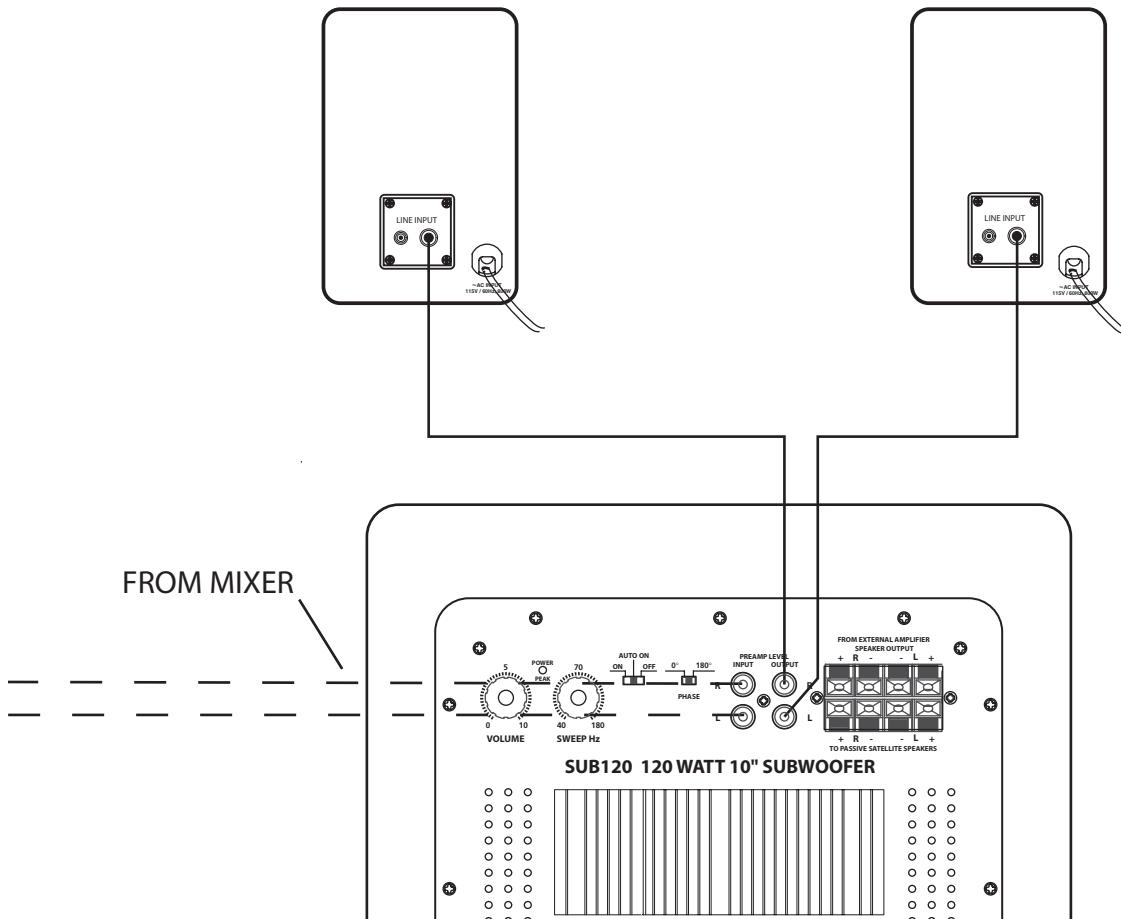

- Lower your mixer's master outputs to all the way off.
- Connect the mixer's left output to the SUB120's LEFT LINE INPUT and the mixer's right output to the SUB120's RIGHT LINE INPUT. Now connect the SUB120's LEFT LINE OUTPUT to the input of the left powered satellite, and the SUB120's RIGHT LINE OUTPUT to the input of the right powered satellite.
- Now adjust the SWEEP control to the desired frequency. Consult your studio monitors owner's manual for a recommended crossover point. You can also use your ears by adjusting the SWEEP control to the frequency that sounds good to you. A good place to start is about 70 Hz.
- Now set the level of your power amp up to the normal operating level. Run an audio signal (like some music from a CD) through your mixer and raise the level to a comfortable listening level. Now slowly raise the SUB120 VOLUME control and listen to the low frequency output. Adjust the SUB120 to the level of low frequency output that you like. Now, when you raise and lower your mixer's output, the SUB120 and satellites will track at the same relative volume.

Connecting the SUB120

Stereo Sub With Passive Satellites

Two SUB120's can be used with any pair of passive or active monitors. Below is a typical system set using two SUB120's with a mixer, stereo power amp and a pair of passive satellite loud speakers. The SUB120's input and outputs utilize industry standard RCA connectors. For a detailed wiring diagram, see the section SUB120 Connections on page 15. Follow the steps below the diagram to set up your system

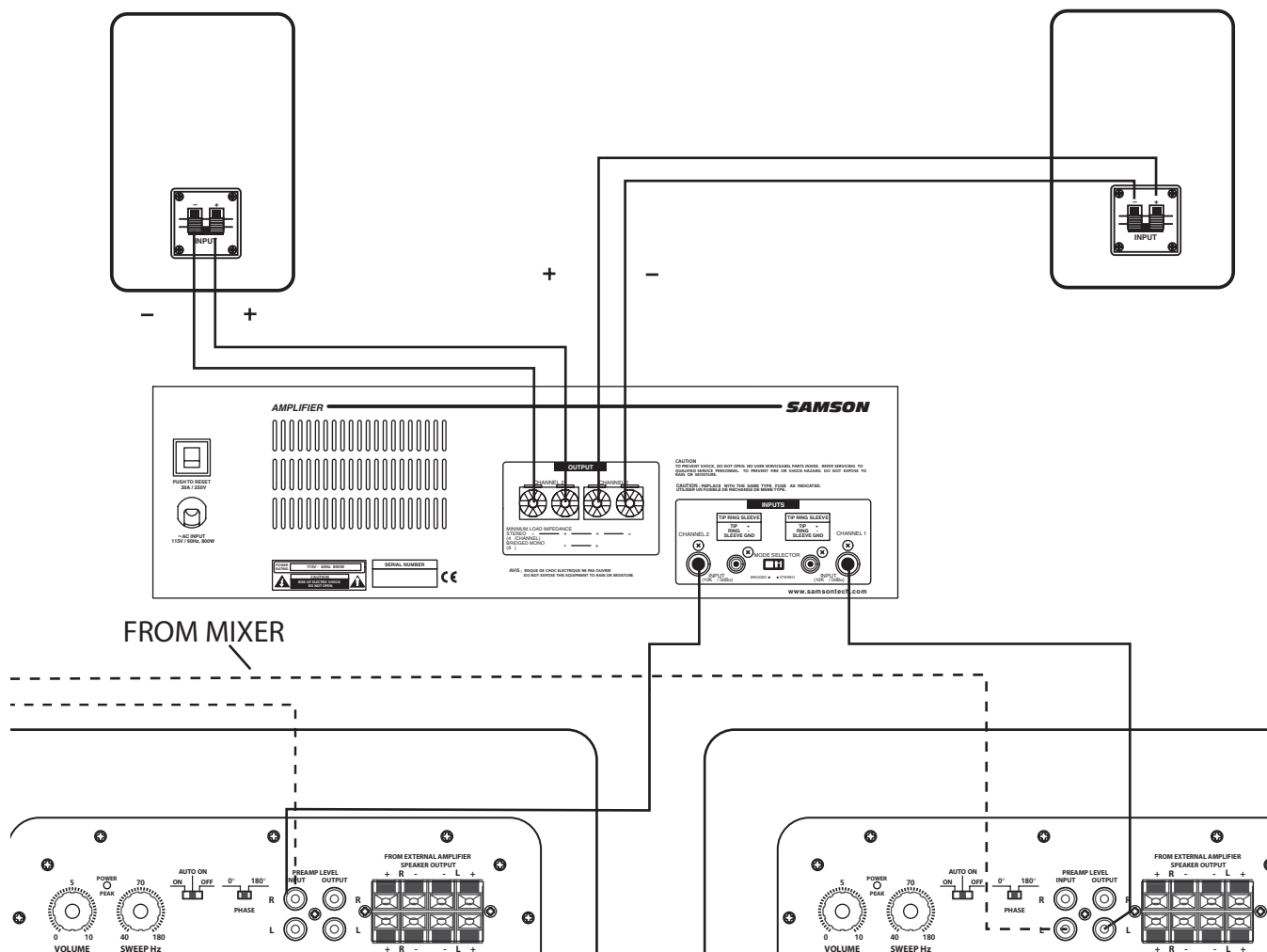

- Lower your mixer's master outputs to all the way off.
- Connect the mixer's left output to the left side SUB120's LEFT PREAMP INPUT and the mixer's right output to the right side SUB120's RIGHT PREAMP LEVEL INPUT. Now connect the left SUB120's LEFT PREAMP OUTPUT to the left side input of the power amp, and the right SUB120's RIGHT PREAMP LEVEL OUTPUT to the right side input of the power amp. Connect a speaker wire from the left output of your power amp to your left satellite, and then, connect a speaker wire from the right output of your power amp to your right satellite.
- Now adjust the SWEEP control to the desired frequency. Consult your studio monitors owner's manual for a recommended crossover point. You can also use your ears by adjusting the SWEEP control to the frequency that sounds good to you. A good place to start is about 70 Hz.
- Now set the level of your power amp up to the normal operating level. Run an audio signal (like some music from a CD) through your mixer and raise the level to a comfortable listening level. Now slowly raise the SUB120 Volume control and listen to the low frequency output. Adjust the SUB120 to the level of low frequency output that you like. Now, when you raise and lower your mixer's output, the SUB120 and satellites will track at the same relative volume.

SUB120 Connections

SUB120 Wiring Guide

There are several ways to interface the SUB120 depending on your exact monitoring set-up. The SUB120 features both Preamp Level and Speaker Level inputs and outputs, so connecting to any active or passive satellites speakers is easy. Follow the cable diagrams below for connecting your monitor system.

Speaker Cable (Un-Shielded)

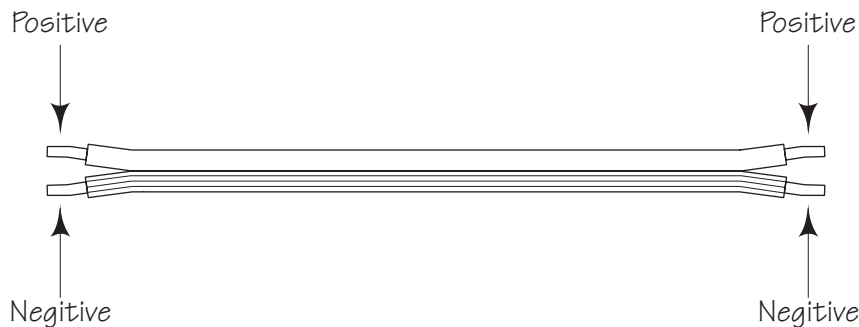

Note: Just about all un-shielded speaker wire will have a marking indicating the negative side. To avoid phase cancellation problems, be sure to maintain the correct connection for the positive and negative sides throughout your system.

Unbalanced 1/4" to RCA Cable

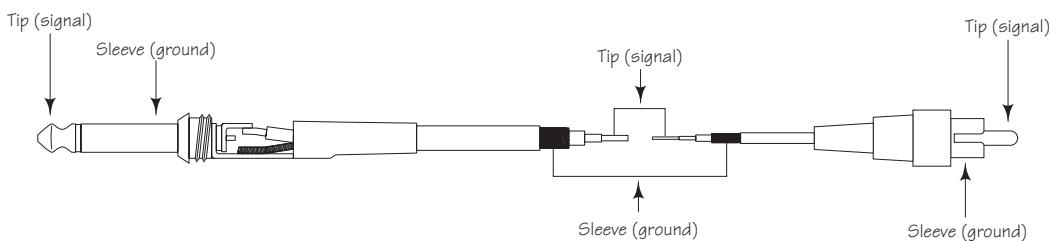

Un-Balanced XLR to RCA Cable

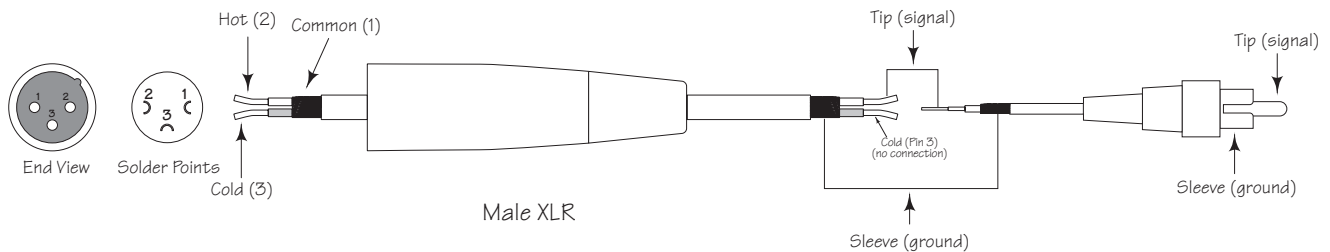

Specifications

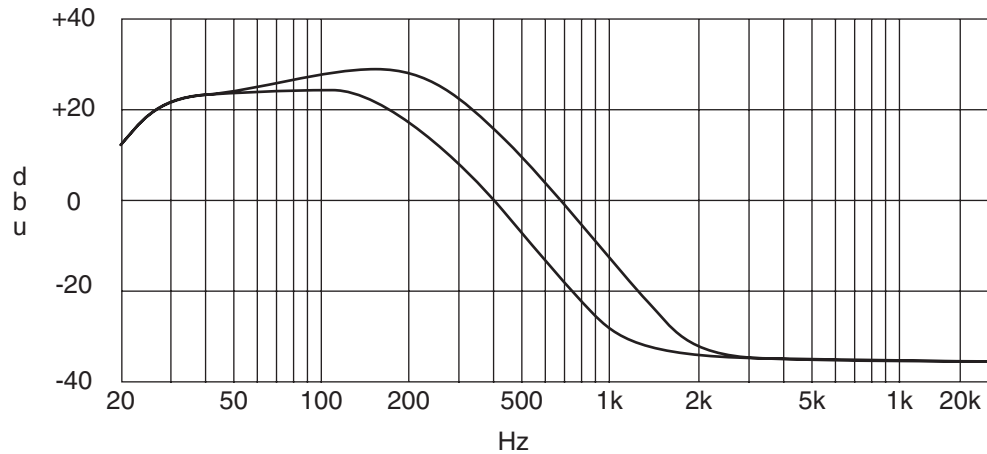

Sub 120 Frequency Chart

Specifications

Transducer: 10", Long Excursion (25mm) Transducer

Amplifier
 Power Rating: 120 Watts RMS
 Frequency response: 30Hz- 300Hz+/-3 dB
 Sensitivity: 94dB SPL @ 1 W/1m

Speaker Input
 Connector: Push Terminal

Speaker Output
 Connector: High-passed.
 Push Terminal

Line Input
 Connector: Un-Balanced
 RCA - FEMALE

Line Output
 Connector: Un-Balanced
 RCA - FEMALE

Crossover Frequency: Variable 40Hz – 180Hz

Enclosure
 Construction: MDF (Medium Density Fiberboard)
 Finish: Black Vinyl
 Feet: Large Rubber

Dimensions: 17" (h) x 14 (w) x 16.25 (d)
 432 mm (h) x 356 (w) x 413 (d)

Weight: 39 lbs.
 17.75 kg.

Samson Technologies Corp.
575 Underhill Blvd.
P.O. Box 9031
Syosset, NY 11791-9031
Phone: 1-800-3-SAMSON (1-800-372-6766)
Fax: 516-364-3888
www.samsontech.com

Free Manuals Download Website

<http://myh66.com>

<http://usermanuals.us>

<http://www.somanuals.com>

<http://www.4manuals.cc>

<http://www.manual-lib.com>

<http://www.404manual.com>

<http://www.luxmanual.com>

<http://aubethermostatmanual.com>

Golf course search by state

<http://golfingnear.com>

Email search by domain

<http://emailbydomain.com>

Auto manuals search

<http://auto.somanuals.com>

TV manuals search

<http://tv.somanuals.com>