

# DDR3 SDRAM Product Guide

October 2009

Memory Division

1. DDR3 SDRAM Component Ordering Information

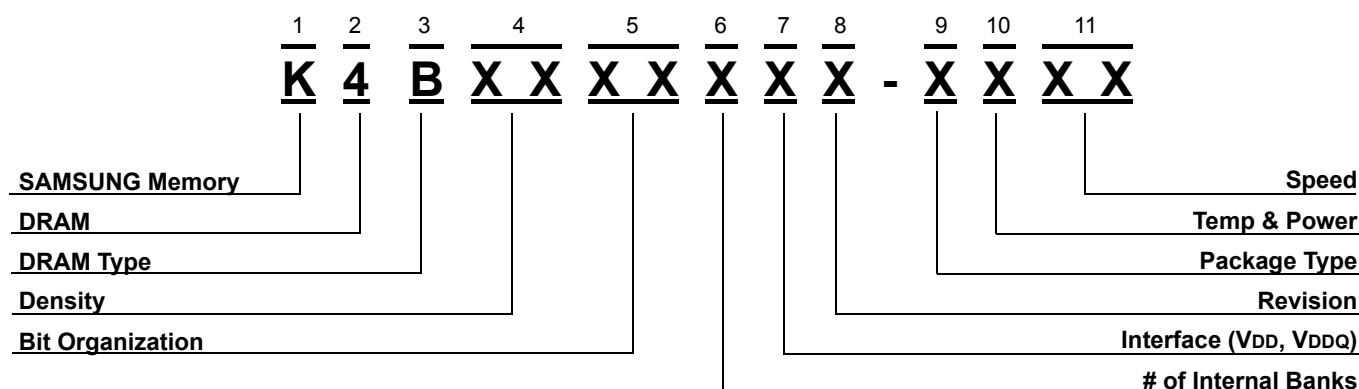

1. SAMSUNG Memory : K

2. DRAM : 4

3. DRAM Type  
B : DDR3 SDRAM

4. Density  
51 : 512Mb  
1G : 1Gb  
2G : 2Gb  
4G : 4Gb

5. Bit Organization  
04 : x 4  
08 : x 8  
16 : x16

6. # of Internal Banks  
3 : 4 Banks  
4 : 8 Banks  
5 : 16 Banks

7. Interface ( VDD, VDDQ)  
6 : SSTL (1.5V, 1.5V)

8. Revision  
M : 1st Gen.  
A : 2nd Gen.  
B : 3rd Gen.  
C : 4th Gen.  
D : 5th Gen.  
E : 6th Gen.  
F : 7th Gen.  
G : 8th Gen.  
H : 9th Gen.

9. Package Type  
Z : FBGA (Lead-free)  
H : FBGA (Halogen-free & Lead-free)  
J : FBGA (Lead-free, DDP)  
M : FBGA (Halogen-free & Lead-free, DDP)

10. Temp & Power  
C : Commercial Temp.( 0°C ~ 85°C) & Normal Power  
L : Commercial Temp.( 0°C ~ 85°C) & Low Power  
Y : Commercial Temp.( 0°C ~ 85°C) & Low VDD(1.35V)

11. Speed  
F7 : DDR3-800 (400MHz @ CL=6, tRCD=6, tRP=6)  
F8 : DDR3-1066 (533MHz @ CL=7, tRCD=7, tRP=7)  
H9 : DDR3-1333 (667MHz @ CL=9, tRCD=9, tRP=9)  
K0 : DDR3-1600 (800MHz @ CL=11, tRCD=11, tRP=11)

2. DDR3 SDRAM Component Product Guide

Density	Banks	Part Number	Package & Power, Temp. (-C/-L) & Speed	Org.	VDD Voltage	PKG	Avail.	Note
1Gb D-die	8Banks	K4B1G0446D	HC(L)F7/F8/H9	256M x 4	1.5V	78 + 4 ball FBGA	Now	
		K4B1G0846D	HC(L)F7/F8/H9	128M x 8				
		K4B1G1646D	HC(L)F7/F8/H9	64M x 16		96 + 4 ball FBGA		
1Gb E-die	8Banks	K4B1G0446E	HC(L)F7/F8/H9/K0	256M x 4	1.5V	78 ball FBGA	Now	
		K4B1G0846E	HC(L)F7/F8/H9/K0	128M x 8		96 ball FBGA		
		K4B1G1646E	HC(L)F7/F8/H9/K0	64M x 16				
		K4B1G0446E	HYF7/F8/H9/K0	256M x 4	1.35V	78 ball FBGA		
		K4B1G0846E	HYF7/F8/H9/K0	128M x 8				
1Gb F-die	8Banks	K4B1G0446F	HC(L)F8/H9	256M x 4	1.5V	78 ball FBGA	Now	
		K4B1G0846F	HC(L)F8/H9	128M x 8	1.35V			
		K4B1G0446F	HY(L)F8/H9	256M x 4				
		K4B1G0846F	HY(L)F8/H9	128M x 8				
2Gb B-die	8Banks	K4B2G0446B	HC(L)F7/F8/H9	512M x 4	1.5V	78 ball FBGA	Now	
		K4B2G0846B	HC(L)F7/F8/H9	256M x 8		96 ball FBGA		
		K4B2G1646B	HC(L)F7/F8/H9	128M x 16				
		K4B2G0446B	HYF7/F8/H9	512M x 4	1.35V	78 ball FBGA		
		K4B2G0846B	HYF7/F8/H9	256M x 8				
2Gb C-die	8Banks	K4B2G0446C	HC(L)F8/H9	512M x 4	1.5V	78 ball FBGA	Now	
		K4B2G0846C	HC(L)F8/H9	256M x 8	1.35V			
		K4B2G0446C	HY(L)F8/H9	512M x 4				
		K4B2G0846C	HY(L)F8/H9	256M x 8				
DDP 2Gb D-die	8Banks	K4B2G0446D	MC(L)F7/F8/H9	512M x 4	1.5V	78 ball FBGA	Now	
		K4B2G0846D	MC(L)F7/F8/H9	256M x 8				
DDP 2Gb E-die	8Banks	K4B2G0446E	MC(L)F7/F8/H9	512M x 4	1.5V	78 ball FBGA	Now	
		K4B2G0846E	MC(L)F7/F8/H9	256M x 8				
DDP 4Gb B-die	8Banks	K4B4G0446B	MC(L)F7/F8/H9	1G x 4	1.5V	78 ball FBGA	Now	
		K4B2G0846B	MC(L)F7/F8/H9	512M x 8				

\* Note : 1.35V product is 1.5V operatable.

3. DDR3 SDRAM Module Ordering Information

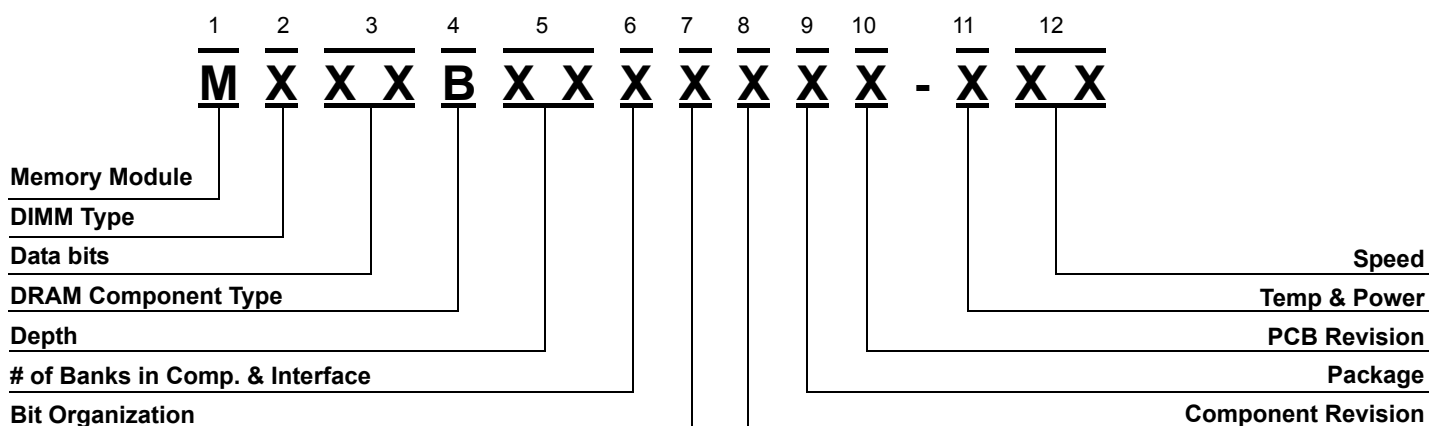

1. Memory Module : M

2. DIMM Type

- 3 : DIMM
- 4 : SODIMM

3. Data Bits

- 71 : x64 204pin Unbuffered SODIMM
- 78 : x64 240pin Unbuffered DIMM
- 91 : x72 240pin ECC unbuffered DIMM
- 92 : x72 240pin VLP Registered DIMM
- 93 : x72 240pin Registered DIMM

4. DRAM Component Type

- B : DDR3 SDRAM (1.5V VDD)

5. Depth

- 32 : 32M
- 33 : 32M (for 128Mb/512Mb)
- 64 : 64M
- 65 : 64M (for 128Mb/512Mb)
- 28 : 128M
- 29 : 128M (for 128Mb/512Mb)
- 56 : 256M
- 57 : 256M (for 512Mb/2Gb)
- 51 : 512M
- 52 : 512M (for 512Mb/2Gb)
- 1G : 1G
- 1K : 1G (for 2Gb)
- 2G : 2G
- 2K : 2G (for 2Gb)

6. # of Banks in comp. & Interface

- 7 : 8Banks & SSTL-1.5V

7. Bit Organization

- 0 : x 4
- 3 : x 8
- 4 : x16

8. Component Revision

- M : 1st Gen.
- A : 2nd Gen.
- B : 3rd Gen.
- C : 4th Gen.
- D : 5th Gen.
- E : 6th Gen.
- F : 7th Gen.
- G : 8th Gen.

9. Package

- Z : FBGA(Lead-free)
- H : FBGA(Lead-free & Halogen-free)
- J : FBGA(Lead-free, DDP)
- M : FBGA(Lead-free & Halogen-free, DDP)

10. PCB Revision

- 0 : None
- 1 : 1st Rev.
- 2 : 2nd Rev.
- 3 : 3rd Rev.
- 4 : 4th Rev.
- S : Reduced Layer

11. Temp & Power

- C : Commercial Temp.( 0°C ~ 85°C) & Normal Power
- Y : Commercial Temp.( 0°C ~ 85°C) & Low VDD(1.35V)

12. Speed

- F7 : DDR3-800 (400MHz @ CL=6, tRCD=6, tRP=6)
- F8 : DDR3-1066 (533MHz @ CL=7, tRCD=7, tRP=7)
- H9 : DDR3-1333 (667MHz @ CL=9, tRCD=9, tRP=9)
- K0 : DDR3-1600 (800MHz @ CL=11, tRCD=11, tRP=11)

Note: PC3-6400(DDR3-800),PC3-8500(DDR3-1066),  
PC3-10600(DDR3-1333), PC3-12800(DDR3-1600)

4. DDR3 SDRAM Module Product Guide

4.1 240Pin DDR3 Unbuffered DIMM (1.5V Product)

240Pin DDR3 Unbuffered DIMM													
Org.	Density	Part Number	Speed	Raw Card	Composition	Comp. Version		Internal Banks	Rank	PKG	Height	Avail.	Note
128Mx 64	1GB	M378B2873DZ1	CF8/H9	A(1Rx8)	128M x 8 * 8 pcs	1Gb	D-die	8	1	78 + 4 ball FBGA	30mm	Now	
		M378B2873EH1	CF8/H9/K0		128M x 8 * 8 pcs	1Gb	E-die			78 ball FBGA			
		M378B2873FHS	CF8/H9		128M x 8 * 8 pcs	1Gb	F-die						
128Mx 72	1GB	M391B2873DZ1	CF8/H9	D(1Rx8)	128M x 8 * 9 pcs	1Gb	D-die	8	1	78 + 4 ball FBGA	30mm	Now	
		M391B2873EH1	CF8/H9/K0		128M x 8 * 9 pcs	1Gb	E-die			78 ball FBGA			
		M391B2873FH0	CF8/H9/K0		128M x 8 * 9 pcs	1Gb	F-die						
256Mx 64	2GB	M378B5673DZ1	CF8/H9	B(2Rx8)	128M x 8 * 16 pcs	1Gb	D-die	8	2	78 + 4 ball FBGA	30mm	Now	
		M378B5673EH1	CF8/H9/K0		128M x 8 * 16 pcs	1Gb	E-die			78 ball FBGA			
		M378B5673FH0	CF8/H9/K0		128M x 8 * 16 pcs	1Gb	F-die						
		M378B5773CHS	CF8/H9/K0	A(1Rx8)	256M x 8 * 8 pcs	2Gb	C-die	8	1				
256Mx 72	2GB	M391B5673DZ1	CF8/H9	E(2Rx8)	128M x 8 * 18 pcs	1Gb	D-die	8	2	78 + 4 ball FBGA	30mm	Now	
		M391B5673EH1	CF8/H9/K0		128M x 8 * 18 pcs	1Gb	E-die			78 ball FBGA			
		M391B5673FH0	CF8/H9/K0		128M x 8 * 18 pcs	1Gb	F-die						
		M391B5773CH0	CF8/H9/K0	D(1Rx8)	256M x 8 * 9 pcs	2Gb	C-die		1				
512Mx 64	4GB	M378B5273BH1	CF8/H9	B(2Rx8)	256M x 8 * 16 pcs	2Gb	B-die	8	2	78 ball FBGA	30mm	Now	
		M378B5273CH0	CF8/H9/K0		256M x 8 * 16 pcs	2Gb	C-die						
512Mx 72	4GB	M391B5273BH1	CF8/H9	E(2Rx8)	256M x 8 * 18 pcs	2Gb	B-die	8	2	78 ball FBGA	30mm	Now	
		M391B5273CH0	CF8/H9/K0		256M x 8 * 18 pcs	2Gb	C-die						

4.2 240Pin DDR3 Unbuffered DIMM (1.35V Product)

240Pin DDR3 Unbuffered DIMM													
Org.	Density	Part Number	Speed	Raw Card	Composition	Comp. Version		Internal Banks	Rank	PKG	Height	Avail.	Note
128Mx 72	1GB	M391B2873EH1	YF8/H9	D(1Rx8)	128M x 8 * 9 pcs	1Gb	E-die	8	1	78 ball FBGA	30mm	Now	
		M391B2873FH0	YF8/H9		128M x 8 * 9 pcs	1Gb	F-die						
256Mx 72	2GB	M391B5673EH1	YF8/H9	E(2Rx8)	128M x 8 * 18 pcs	1Gb	E-die	8	2	78 ball FBGA	30mm	Now	
		M391B5673FH0	YF8/H9		128M x 8 * 18 pcs	1Gb	F-die						
		M391B5773CH0	YF8/H9	D(1Rx8)	256M x 8 * 9 pcs	2Gb	C-die	8	1				
512Mx 72	4GB	M391B5273BH1	YF8/H9	E(2Rx8)	256M x 8 * 18 pcs	2Gb	B-die	8	2	78 ball FBGA	30mm	Now	
		M391B5273CH0	YF8/H9		256M x 8 * 18 pcs	2Gb	C-die						

\* Note : 1.35V product is 1.5V operatable.

## 4.3 204Pin DDR3 SoDIMM (1.5V Product)

204Pin DDR3 SODIMM													
Org.	Density	Part Number	Speed	Raw Card	Composition	Comp. Version		Internal Banks	Rank	PKG	Height	Avail.	Note
128Mx 64	1GB	M471B2874DZ1	CF8/H9	A(2Rx16)	64M x 16 * 8 pcs	1Gb	D-die	8	2	96 + 4 ball FBGA	30mm	Now	
		M471B2873EH1	CF8/H9	B(1Rx8)	128M x 8 * 8 pcs	1Gb	E-die	8	1	78 ball FBGA			
		M471B2874EH1	CF8/H9	A(2Rx16)	64M x 16 * 8 pcs	1Gb	E-die	8	2	96 ball			
		M471B2873FHS	CF8/H9	B(1Rx8)	64M x 16 * 8 pcs	1Gb	F-die	8	1	78 ball FBGA			
256Mx 64	2GB	M471B5673DZ1	CF8/H9	F(2Rx8)	128M x 8 * 16 pcs	1Gb	D-die	8	2	78 + 4 ball FBGA	30mm	Now	
		M471B5673EH1	CF8/H9		128M x 8 * 16 pcs	1Gb	E-die			78 ball FBGA			
		M471B5673FH0	CF8/H9		128M x 8 * 16 pcs	1Gb	F-die						
		M471B5773CHS	CF8/H9	B(1Rx8)	256M x 8 * 8 pcs	2Gb	C-die	8	1				
512Mx 64	4GB	M471B5273BH1	CF8/H9	F(2Rx8)	256M x 8 * 16 pcs	2Gb	B-die	8	2	78 ball FBGA	30mm	Now	
		M471B5273CH0	CF8/H9		256M x 8 * 16 pcs	2Gb	C-die						

## 4.4 204Pin DDR3 SoDIMM (1.35V Product)

204Pin DDR3 SODIMM													
Org.	Density	Part Number	Speed	Raw Card	Composition	Comp. Version		Internal Banks	Rank	PKG	Height	Avail.	Note
128Mx 64	1GB	M471B2873EH1	YF8/H9	B(1Rx8)	128M x 8 * 8 pcs	1Gb	E-die	8	1	78 ball FBGA	30mm	Now	
		M471B2874EH1	YF8/H9	A(1Rx16)	64M x 16 * 8 pcs	1Gb	E-die	8	2	96 ball			
		M471B2873FHS	YF8/H9	B(1Rx8)	128M x 8 * 8 pcs	1Gb	F-die	8	1	78 ball FBGA			
256Mx 64	2GB	M471B5673EH1	YF8/H9	F(2Rx8)	128M x 8 * 16 pcs	1Gb	E-die	8	2	78 ball FBGA	30mm	Now	
		M471B5673FH0	YF8/H9		128M x 8 * 16 pcs	1Gb	F-die						
		M471B5773CHS	YF8/H9	B(1Rx8)	256M x 8 * 8 pcs	2Gb	C-die	8	1				
512Mx 64	4GB	M471B5273BH1	YF8/H9	F(2Rx8)	256M x 8 * 16 pcs	2Gb	B-die	8	2	78 ball FBGA	30mm	Now	
		M471B5273CH0	YF8/H9		256M x 8 * 16 pcs	2Gb	C-die						

\* Note : 1.35V product is 1.5V operatable.

4.5 240Pin DDR3 Registered DIMM (1.5V Product)

240Pin DDR3 Registered DIMM													
Org.	Density	Part Number	Speed	Raw Card	Composition	Comp. Version		Internal Banks	Rank	PKG	Height	Avail.	Note
128Mx 72	1GB	M393B2873DZ1	CF8/H9	A(1Rx8)	128M x 8 * 9 pcs	1Gb	D-die	8	1	78 + 4 ball FBGA	30mm	Now	
		M393B2873EH1	CF8/H9		128M x 8 * 9 pcs	1Gb	E-die			78 ball FBGA			
		M393B2873FH0	CF8/H9		128M x 8 * 9 pcs	1Gb	F-die						
256Mx 72	2GB	M393B5673DZ1	CF8/H9	B(2Rx8)	128M x 8 * 18 pcs	1Gb	D-die	8	2	78 + 4 ball FBGA	30mm	Now	
		M393B5673EH1	CF8/H9		128M x 8 * 18 pcs	1Gb	E-die		2	78 ball FBGA			
		M393B5673FH0	CF8/H9		128M x 8 * 18 pcs	1Gb	F-die						
		M393B5670DZ1	CF8/H9	C(1Rx4)	256M x 4 * 18 pcs	1Gb	D-die		1	78 + 4 ball FBGA			
		M393B5670EH1	CF8/H9		256M x 4 * 18 pcs	1Gb	E-die		1	78 ball FBGA			
		M393B5670FH0	CF8/H9		256M x 4 * 18 pcs	1Gb	F-die						
512Mx 72	4GB	M393B5173DZ1	CF7/F8	H(4Rx8)	128M x 8 * 36 pcs	1Gb	D-die	8	4	78 + 4 ball FBGA	30mm	Now	
		M393B5173EH1	CF7/F8		128M x 8 * 36 pcs	1Gb	E-die		4	78 ball FBGA			
		M393B5173FH0	CF7/F8		128M x 8 * 36 pcs	1Gb	F-die						
		M393B5170DZ1	CF8/H9	E(2Rx4)	256M x 4 * 36 pcs	1Gb	D-die		2	78 + 4 ball FBGA			
		M393B5170EH1	CF8/H9		256M x 4 * 36 pcs	1Gb	E-die		2	78 ball FBGA			
		M393B5170FH0	CF8/H9		256M x 4 * 36 pcs	1Gb	F-die						
		M393B5273BH1	CF8/H9	B(2Rx8)	256M x 8 * 18 pcs	2Gb	B-die		2				
		M393B5273CH0	CF8/H9		256M x 8 * 18 pcs	2Gb	C-die						
		M393B5270BH1	CF8/H9	C(1Rx4)	512M x 4 * 18 pcs	2Gb	B-die		1				
M393B5270CH0	CF8/H9	512M x 4 * 18 pcs	2Gb		C-die								
1Gx 72	8GB	M393B1G70DJ1	CF7/F8	F(4Rx4)	DDP 512M x 4 * 36 pcs	1Gb	D-die	8	4	78 ball FBGA	30mm	Now	
		M393B1G70EM1	CF7/F8		DDP 512M x 4 * 36 pcs	1Gb	E-die						
		M393B1K73BH1	CF7/F8	H(4Rx8)	256M x 8 * 36 pcs	2Gb	B-die		4				
		M393B1K73CH0	CF7/F8		256M x 8 * 36 pcs	2Gb	C-die						
		M393B1K70BH1	CF8/H9	E(2Rx4)	512M x 4 * 36 pcs	2Gb	B-die		2				
		M393B1K70CH0	CF8/H9		512M x 4 * 36 pcs	2Gb	C-die						
2Gx 72	16GB	M393B2K70BM1	CF7/F8	F(4Rx4)	DDP 1G x 4 * 36 pcs	2Gb	B-die	8	4	78 ball FBGA	30mm	Now	
		M393B2K70CM0	CF7/F8		DDP 1G x 4 * 36 pcs	2Gb	C-die						

## 4.6 240Pin DDR3 Registered DIMM (1.35V Product)

240Pin DDR3 Registered DIMM													
Org.	Density	Part Number	Speed	Raw Card	Composition	Comp. Version		Internal Banks	Rank	PKG	Height	Avail.	Note
128Mx 72	1GB	M393B2873EH1	YF8/H9	A(1Rx8)	128M x 8 * 9 pcs	1Gb	E-die	8	1	78 ball FBGA	30mm	Now	
		M393B2873FH0	YF8/H9		128M x 8 * 9 pcs	1Gb	F-die						
256Mx 72	2GB	M393B5673EH1	YF8/H9	B(2Rx8)	128M x 8 * 18 pcs	1Gb	E-die	8	2	78 ball FBGA	30mm	Now	
		M393B5673FH0	YF8/H9		128M x 8 * 18 pcs	1Gb	F-die						
		M393B5670EH1	YF8/H9	C(1Rx4)	256M x 4 * 18 pcs	1Gb	E-die	8	1				
		M393B5670FH0	YF8/H9		256M x 4 * 18 pcs	1Gb	F-die						
		M393B5773CH0	YF8/H9	A(1Rx8)	512M x 4 * 9 pcs	2Gb	C-die						
512Mx 72	4GB	M393B5173EH1	YF7/F8	H(4Rx8)	128M x 8 * 36 pcs	1Gb	E-die	8	4	78 ball FBGA	30mm	Now	
		M393B5173FH0	YF7/F8		128M x 8 * 36 pcs	1Gb	F-die						
		M393B5170EH1	YF8/H9	E(2Rx4)	256M x 4 * 36 pcs	1Gb	E-die	8	2				
		M393B5170FH0	YF8/H9		256M x 4 * 36 pcs	1Gb	F-die						
		M393B5273BH1	YF8/H9	B(2Rx8)	256M x 8 * 18 pcs	2Gb	B-die	8	2				
		M393B5273CH0	YF8/H9		256M x 8 * 18 pcs	2Gb	C-die						
		M393B5270BH1	YF8/H9	C(1Rx4)	512M x 4 * 18 pcs	2Gb	B-die	8	1				
		M393B5270CH0	YF8/H9		512M x 4 * 18 pcs	2Gb	C-die						
1Gx 72	8GB	M393B1G70EM1	YF7/F8	F(4Rx4)	DDP 512M x 4 * 36 pcs	1Gb	E-die	8	4	78 ball FBGA	30mm	Now	
		M393B1G70FM0	YF7/F8		DDP 512M x 4 * 36 pcs	1Gb	F-die					Nov. '09	
		M393B1K73BH1	YF7/F8	H(4Rx8)	256M x 8 * 36 pcs	2Gb	B-die	8	4			Now	
		M393B1K73CH0	YF7/F8		256M x 8 * 36 pcs	2Gb	C-die						
		M393B1K70BH1	YF8/H9	E(2Rx4)	512M x 4 * 36 pcs	2Gb	B-die	8	2				
		M393B1K70CH0	YF8/H9		512M x 4 * 36 pcs	2Gb	C-die						
2Gx 72	16GB	M393B2K70BM1	YF7/F8	F(4Rx4)	DDP 1G x 4 * 36 pcs	2Gb	B-die	8	4	78 ball FBGA	30mm	Now	
		M393B2K70CM0	YF7/F8		DDP 1G x 4 * 36 pcs	2Gb	C-die					Nov. '09	

\* Note : 1.35V product is 1.5V operatable.



## 4.7 240Pin DDR3 VLP Registered DIMM (1.5V Product)

240Pin DDR3 VLP Registered DIMM														
Org.	Density	Part Number	Speed	Raw Card	Composition	Comp. Version		Internal Banks	Rank	PKG	Height	Avail.	Note	
128Mx 72	1GB	M392B2873DZ1	CF8/H9	K(1Rx8)	128M x 8 * 9 pcs	1Gb	D-die	8	1	78 + 4 ball FBGA	18.75mm	Now		
		M392B2873EH1	CF8/H9			1Gb	E-die			78 ball FBGA				
		M392B2873FH0	CF8/H9			1Gb	F-die							
256Mx 72	2GB	M392B5673DZ1	CF8/H9	L(2Rx8)	128M x 8 * 18 pcs	1Gb	D-die	8	2	78 + 4 ball FBGA	18.75mm	Now		
		M392B5673EH1	CF8/H9			1Gb	E-die			78 ball FBGA				
		M392B5673FH0	CF8/H9			1Gb	F-die							
	M392B5670DZ1	CF8/H9	M(1Rx4)	256M x 4 * 18 pcs	1Gb	D-die	1		78 + 4 ball FBGA					
	M392B5670EH1	CF8/H9			1Gb	E-die			78 ball FBGA					
	M392B5670FH0	CF8/H9			1Gb	F-die								
			M392B5773CH0	CF8/H9	K(1Rx8)	128M x 8 * 9 pcs	1Gb		F-die					1
512Mx 72	4GB	M392B5170DJ1	CF8/H9	N(2Rx4)	DDP 512M x 4 * 18 pcs	1Gb	D-die	8	2	78 ball FBGA	18.75mm	Now		
		M392B5170EM1	CF8/H9			1Gb	E-die							
		M392B5170FM0	CF8/H9			1Gb	F-die							
		M392B5173FM0	CF7/F8	V(4Rx8)	DDP 256M x 8 * 18 pcs	1Gb	F-die							4
	M392B5273BH1	CF8/H9	L(2Rx8)	256M x 8 * 18 pcs	2Gb	B-die	2		Now					
	M392B5273CH0	CF8/H9			2Gb	C-die								
	M392B5270BH1	CF8/H9	M(1Rx4)	512M x 4 * 18 pcs	2Gb	B-die	1							
	M392B5270CH0	CF8/H9			2Gb	C-die								
1Gx 72	8GB	M392B1K73BM1	CF7/F8	V(4Rx8)	DDP 512M x 8 * 18 pcs	2Gb	B-die	8		4	78 ball FBGA	18.75mm	Now	
		M392B1K73CM0	CF7/F8			2Gb	C-die							
		M392B1K70BM1	CF8/H9	N(2Rx4)	DDP 1G x 4 * 18 pcs	2Gb	B-die			2				
		M392B1K70CM0	CF8/H9			2Gb	C-die							

4.8 240Pin DDR3 VLP Registered DIMM (1.35V Product)

240Pin DDR3 VLP Registered DIMM													
Org.	Density	Part Number	Speed	Raw Card	Composition	Comp. Version		Internal Banks	Rank	PKG	Height	Avail.	Note
128Mx 72	1GB	M392B2873EH1	YF8/H9	K(1Rx8)	128M x 8 * 9 pcs	1Gb	E-die	8	1	78 ball FBGA	18.75mm	Now	
		M392B2873FH0	YF8/H9		128M x 8 * 9 pcs	1Gb	F-die						
256Mx 72	2GB	M392B5673EH1	YF8/H9	L(2Rx8)	128M x 8 * 18 pcs	1Gb	E-die	8	2	78 ball FBGA	18.75mm	Now	
		M392B5673FH0	YF8/H9		128M x 8 * 18 pcs	1Gb	F-die						
		M392B5670EH1	YF8/H9	M(1Rx4)	256M x 4 * 18 pcs	1Gb	E-die	8	1				
		M392B5670FH0	YF8/H9		256M x 4 * 18 pcs	1Gb	F-die						
		M392B5773CH0	YF8/H9	K(1Rx8)	512M x 4 * 9 pcs	2Gb	C-die						
512Mx 72	4GB	M392B5170EM1	YF8/H9	N(2Rx4)	DDP 512M x 4 * 18 pcs	1Gb	E-die	8	2	78 ball FBGA	18.75mm	Now	
		M392B5173FM0	YF7/F8	V(4Rx8)	256M x 8 * 18 pcs	1Gb	F-die	8	4			Dec. '09	
		M392B5170FM0	YF8/H9	N(2Rx4)	512M x 4 * 18 pcs	1Gb	F-die	8	2			Now	
		M392B5273BH1	YF8/H9	L(2Rx8)	256M x 8 * 18 pcs	2Gb	B-die						
		M392B5273CH0	YF8/H9		256M x 8 * 18 pcs	2Gb	C-die						
		M392B5270BH1	YF8/H9	M(1Rx4)	512M x 4 * 18 pcs	2Gb	B-die	8	1				
		M392B5270CH0	YF8/H9		512M x 4 * 18 pcs	2Gb	C-die						
1Gx 72	8GB	M392B1K73BM1	YF7/F8	V(4Rx8)	DDP 512M x 8 * 18 pcs	2Gb	B-die	8	4	78 ball FBGA	18.75mm	Now	
		M392B1K73CM0	YF7/F8		DDP 512M x 8 * 18 pcs	2Gb	C-die					Nov. '09	
		M392B1K70BM1	YF8/H9	N(2Rx4)	DDP 1G x 4 * 18 pcs	2Gb	B-die	8	2			Now	
		M392B1K70CM0	YF8/H9		DDP 1G x 4 * 18 pcs	2Gb	C-die					Nov. '09	

\* Note : 1.35V product is 1.5V operatable.

5. RDIMM RCD Information

5.1 RCD Identification in JEDEC Description in Module Label

5.2 Label Example



5.3 RCD Information

- Example

Voltage	Vendor	Revision	Module P/N	JEDEC Description On Label
1.5V	Inphi	GS04 B2	M393B5170EH1-CH9	4GB 2Rx4 PC3-10600R-09-10-E1-P0
	IDT	LV DDR3 B0	M393B5170EH1-CH9	4GB 2Rx4 PC3-10600R-09-10-E1-D2
1.35V	Inphi	LV GS02 C0	M393B5170EH1-YF8	4GB 2Rx4 PC3L-8500R-07-10-E1-P1
	IDT	LV DDR3 B0	M393B5170EH1-YF8	4GB 2Rx4 PC3L-8500R-07-10-E1-D2

78 + 4Ball FBGA for 1Gb D-die (x4/x8)

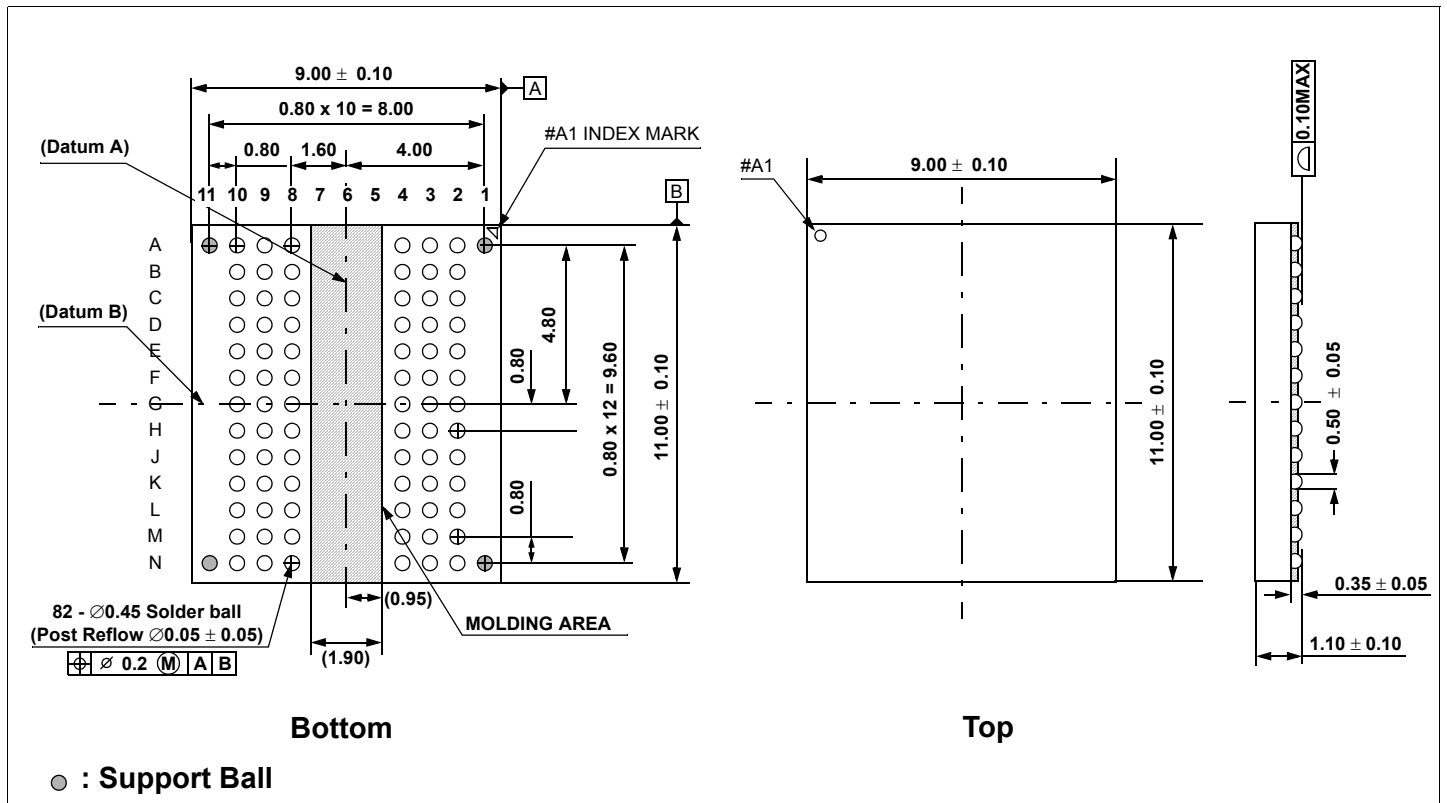

96 + 4Ball FBGA for 1Gb D-die (x16)

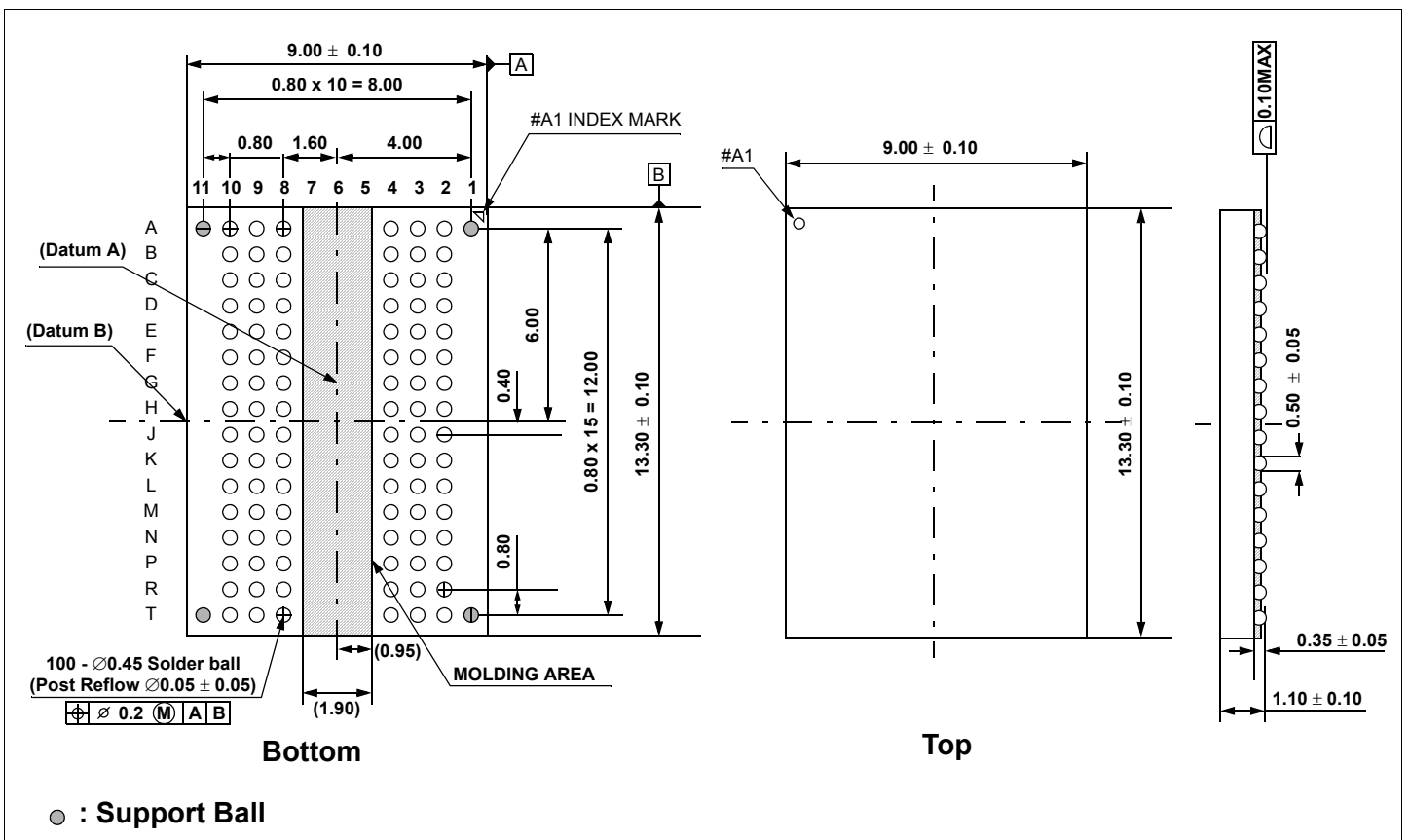

78Ball FBGA for 1Gb E-die (x4/x8) / 1Gb F-die (x4/x8) / 2Gb C-die (x4/x8)

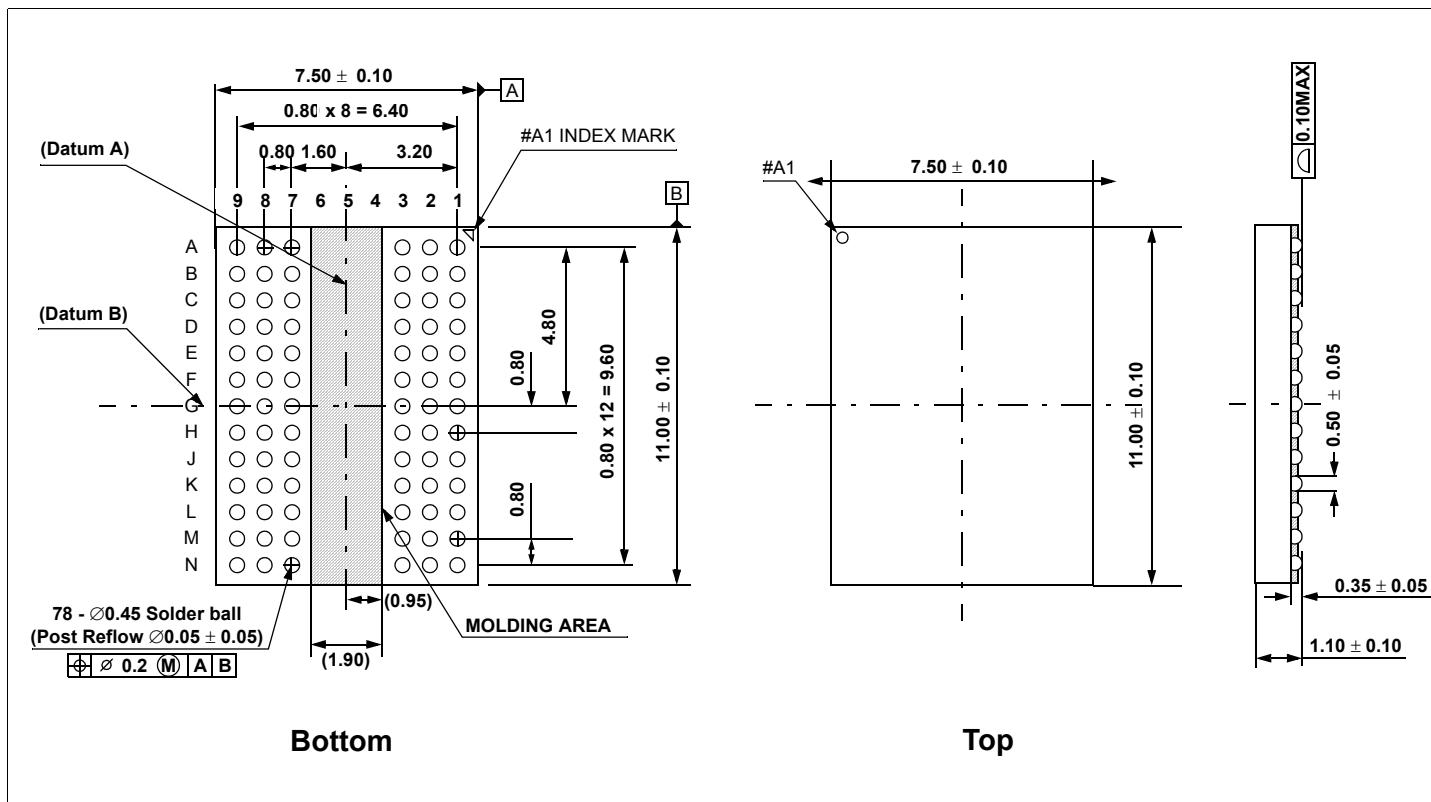

96Ball FBGA for 1Gb E-die (x16)

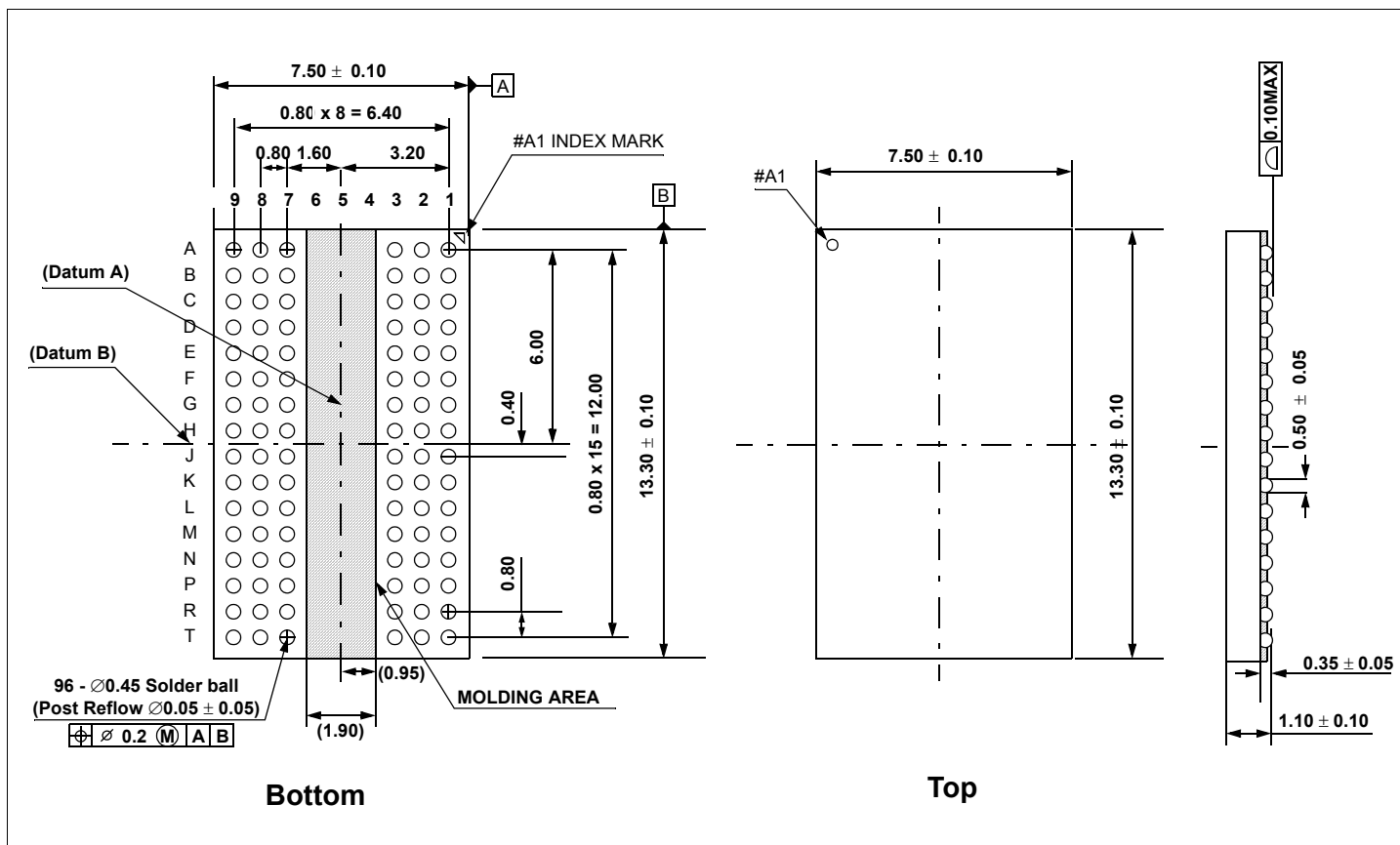

78Ball FBGA for 2Gb B-die (x4/x8)

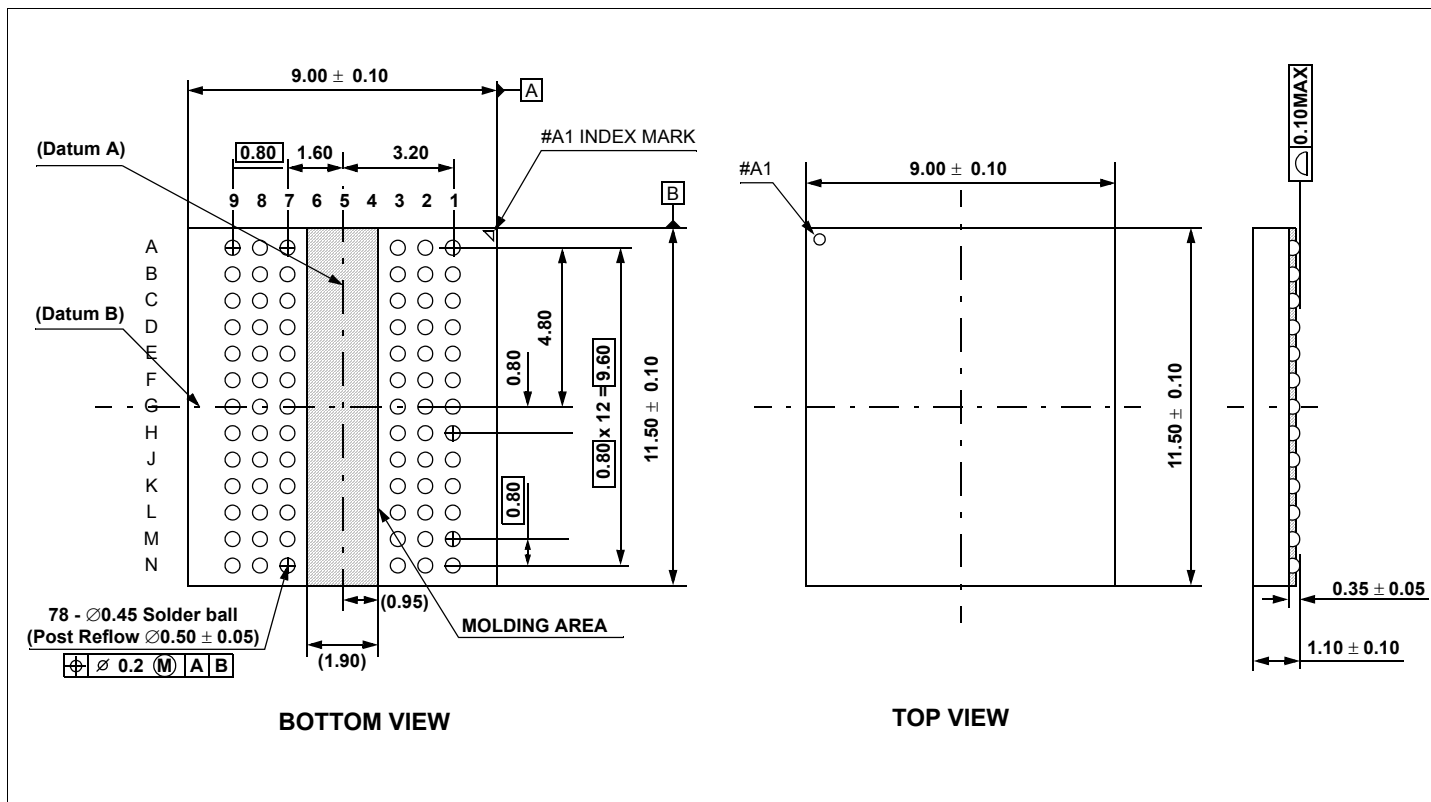

96Ball FBGA for 2Gb B-die (x16)

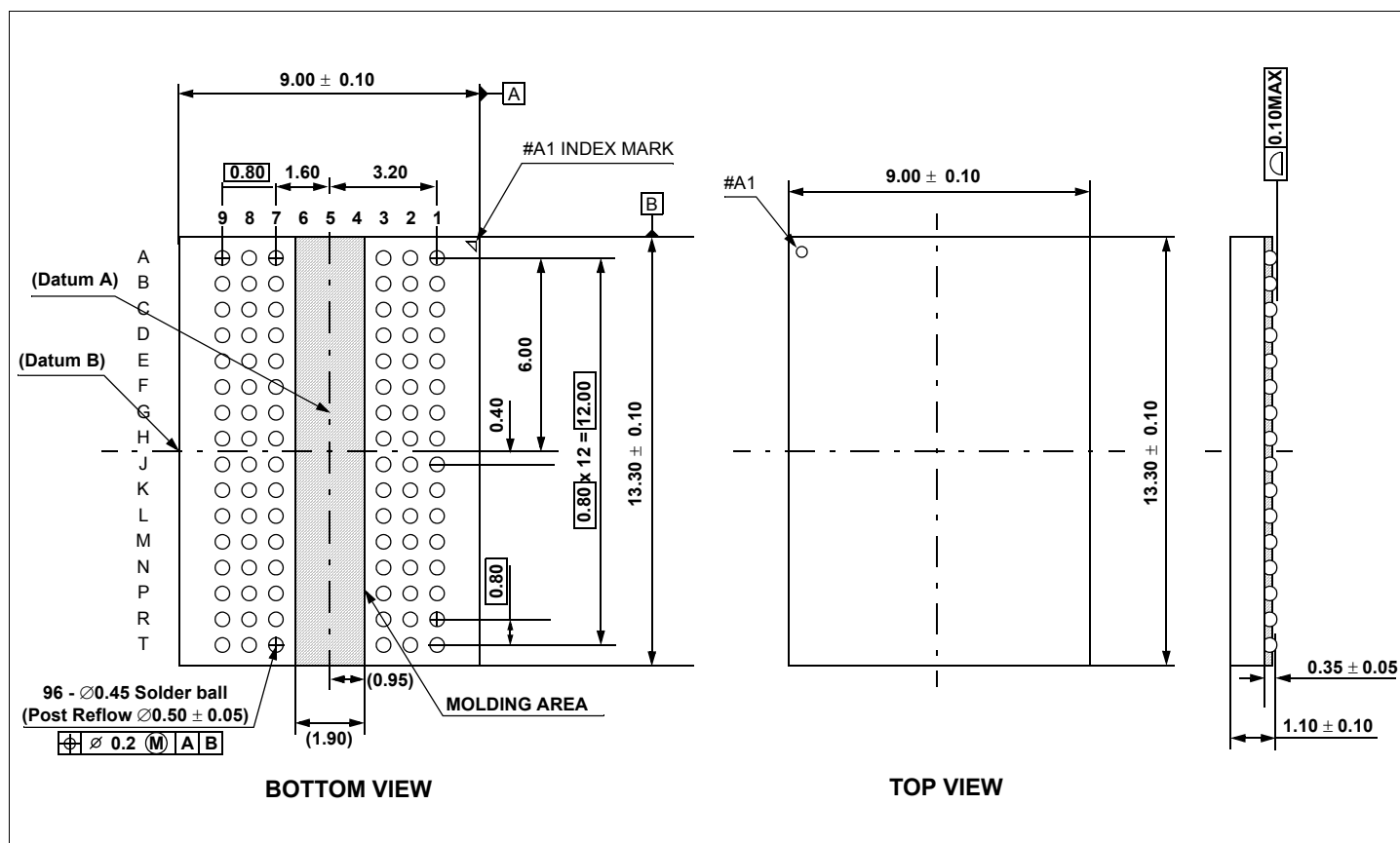

78Ball DDP for 1Gb D-die (x4)

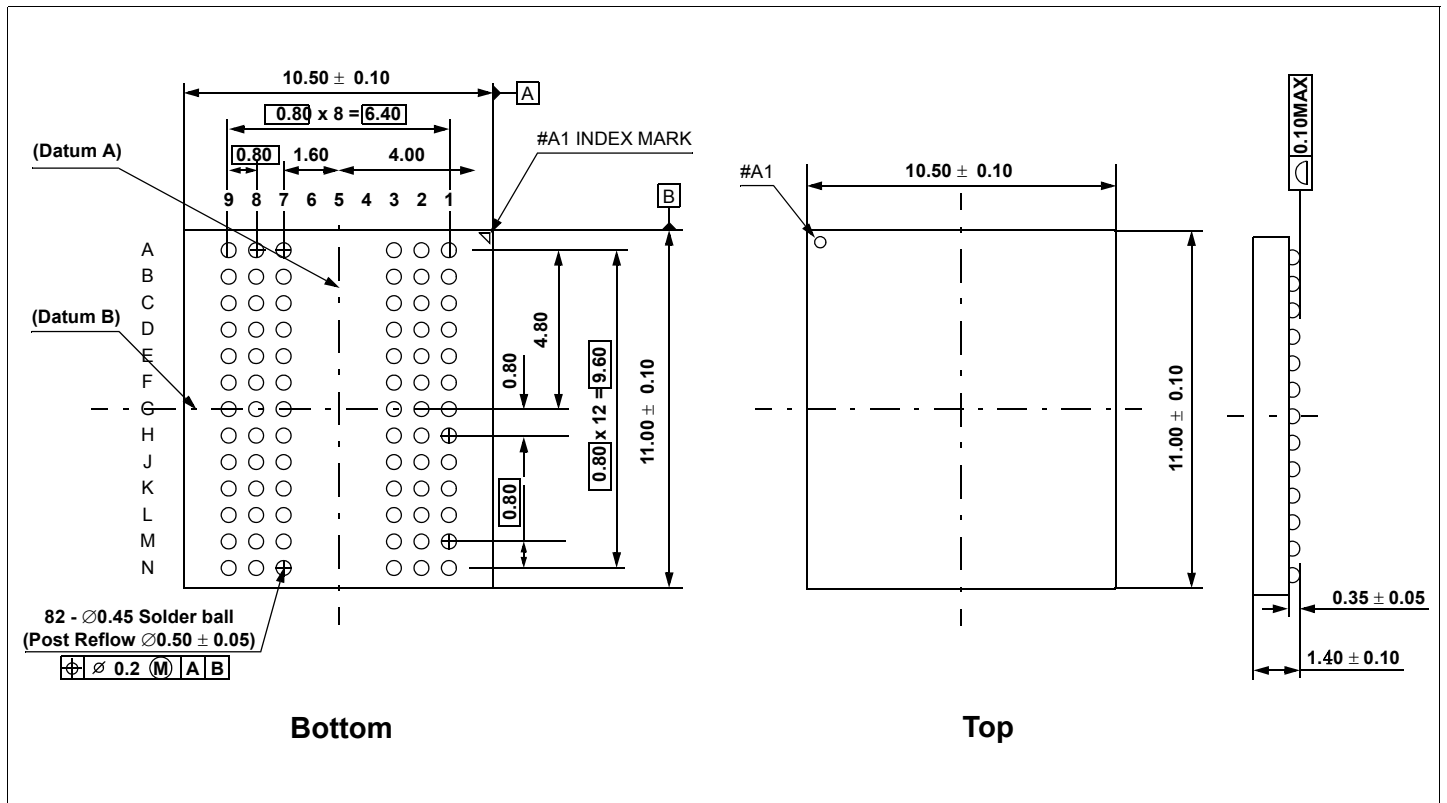

78Ball DDP for 1Gb E-die (x4/x8)

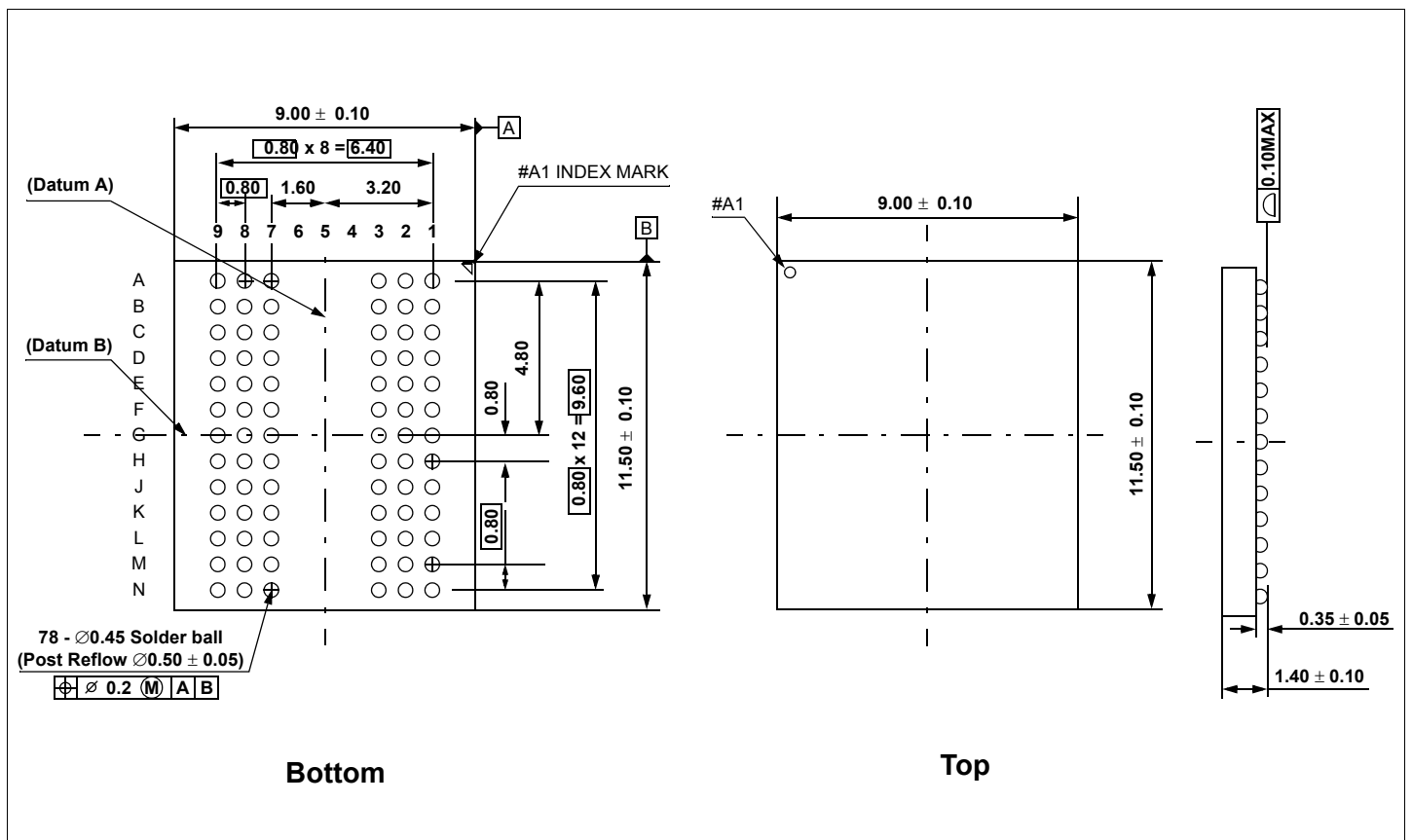

78Ball DDP for 2Gb B-die (x4/x8)

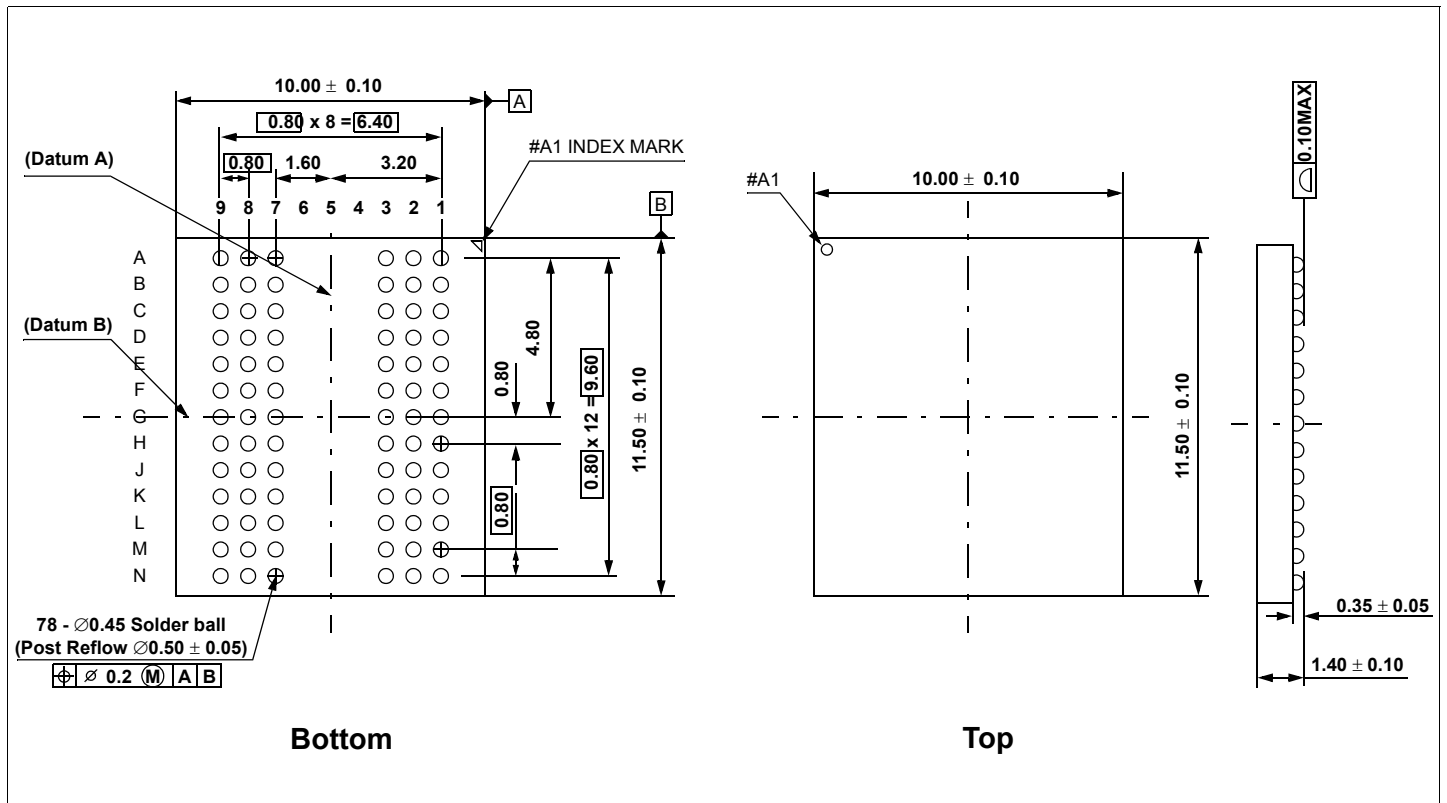



x64/x72 240pin DDR3 SDRAM Unbuffered DIMM

Units : Millimeters

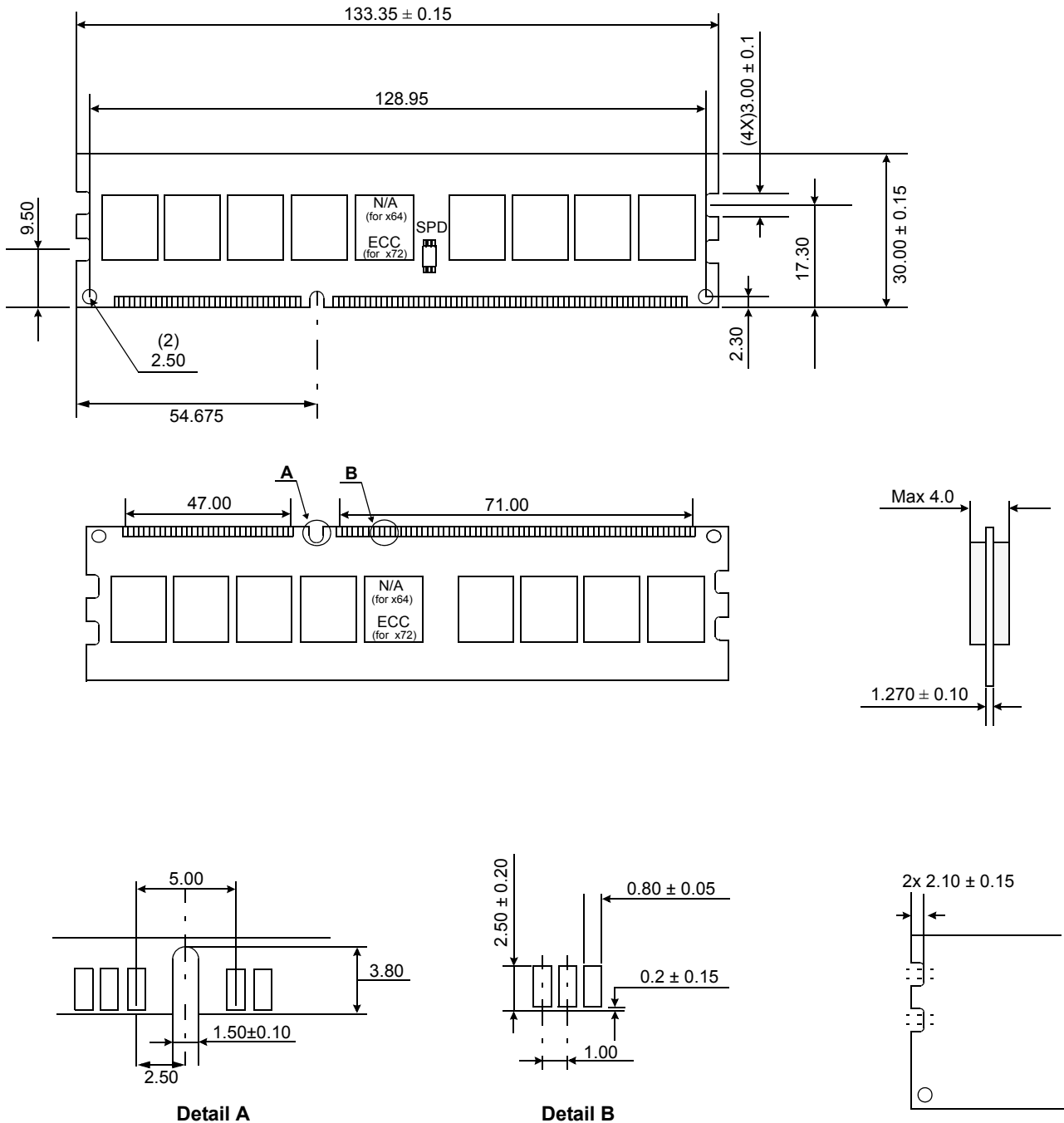

x64 204pin DDR3 SDRAM Unbuffered SODIMM

Units : Millimeters

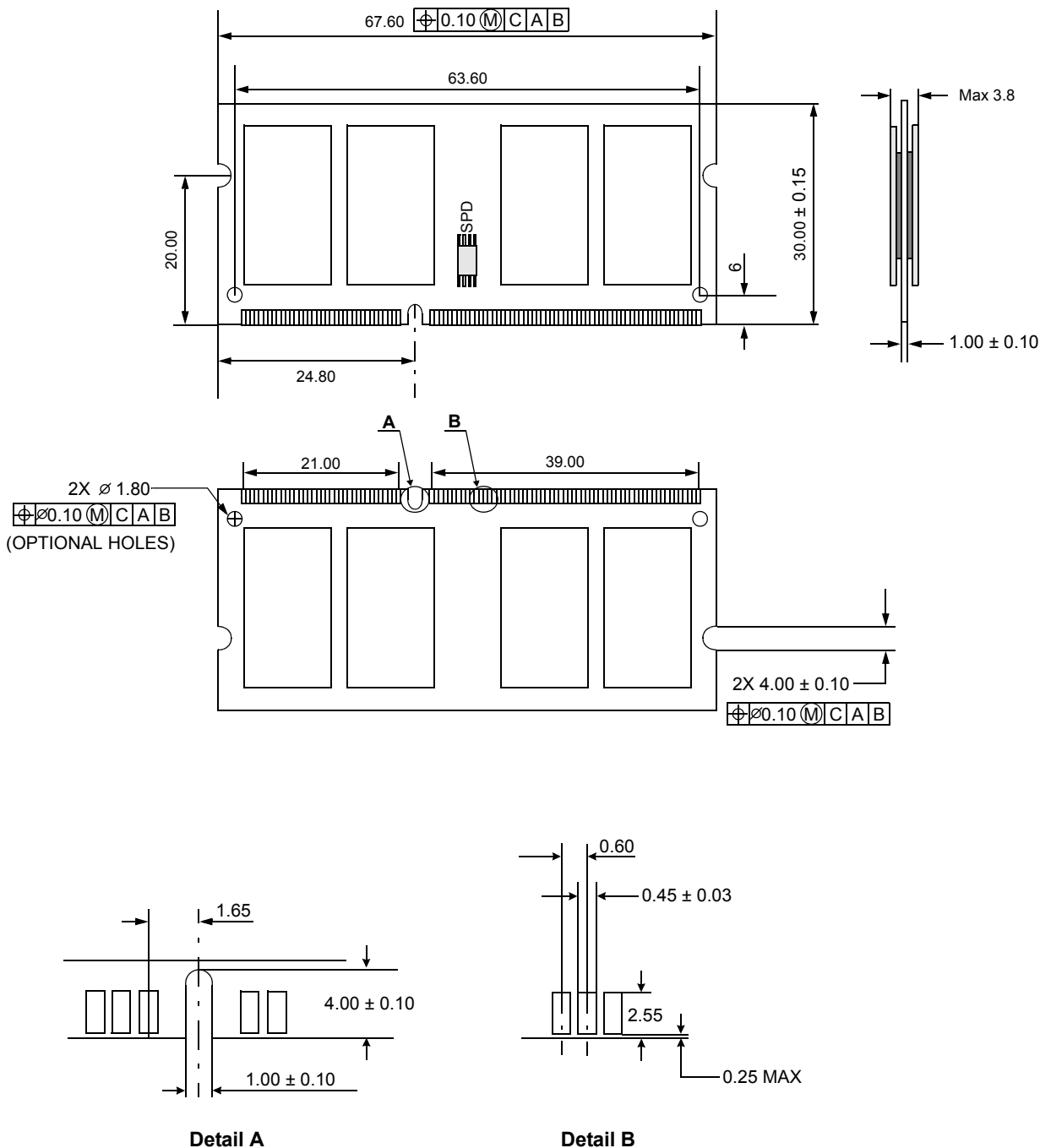

## x72 240pin DDR3 SDRAM Registered DIMM

Units : Millimeters

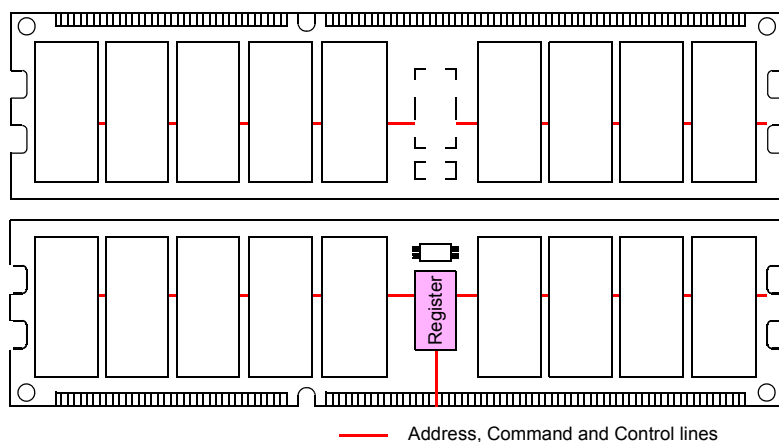
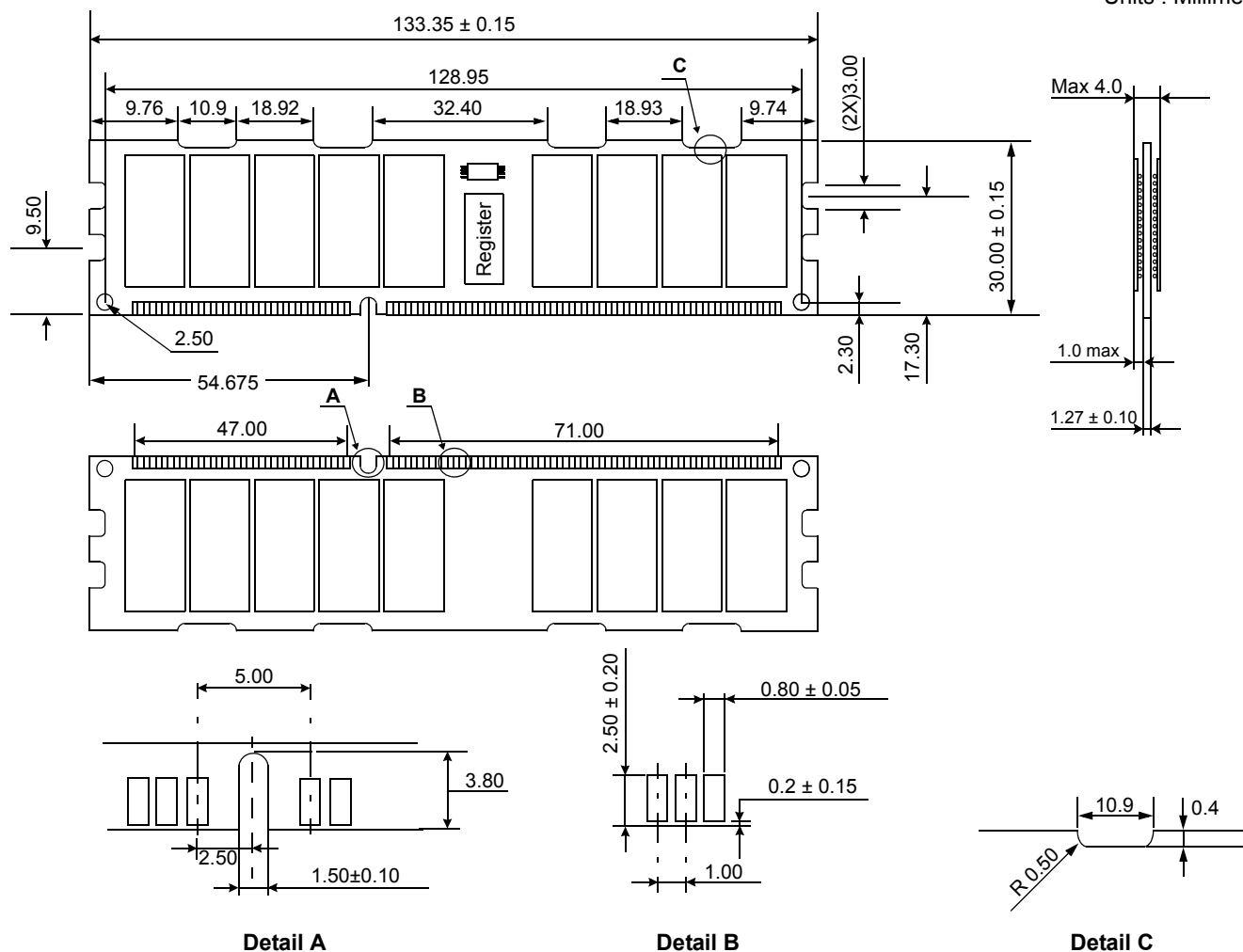

— Address, Command and Control lines

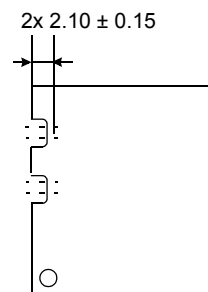

Registered DIMM Heat Spreader Design

1. FRONT PART

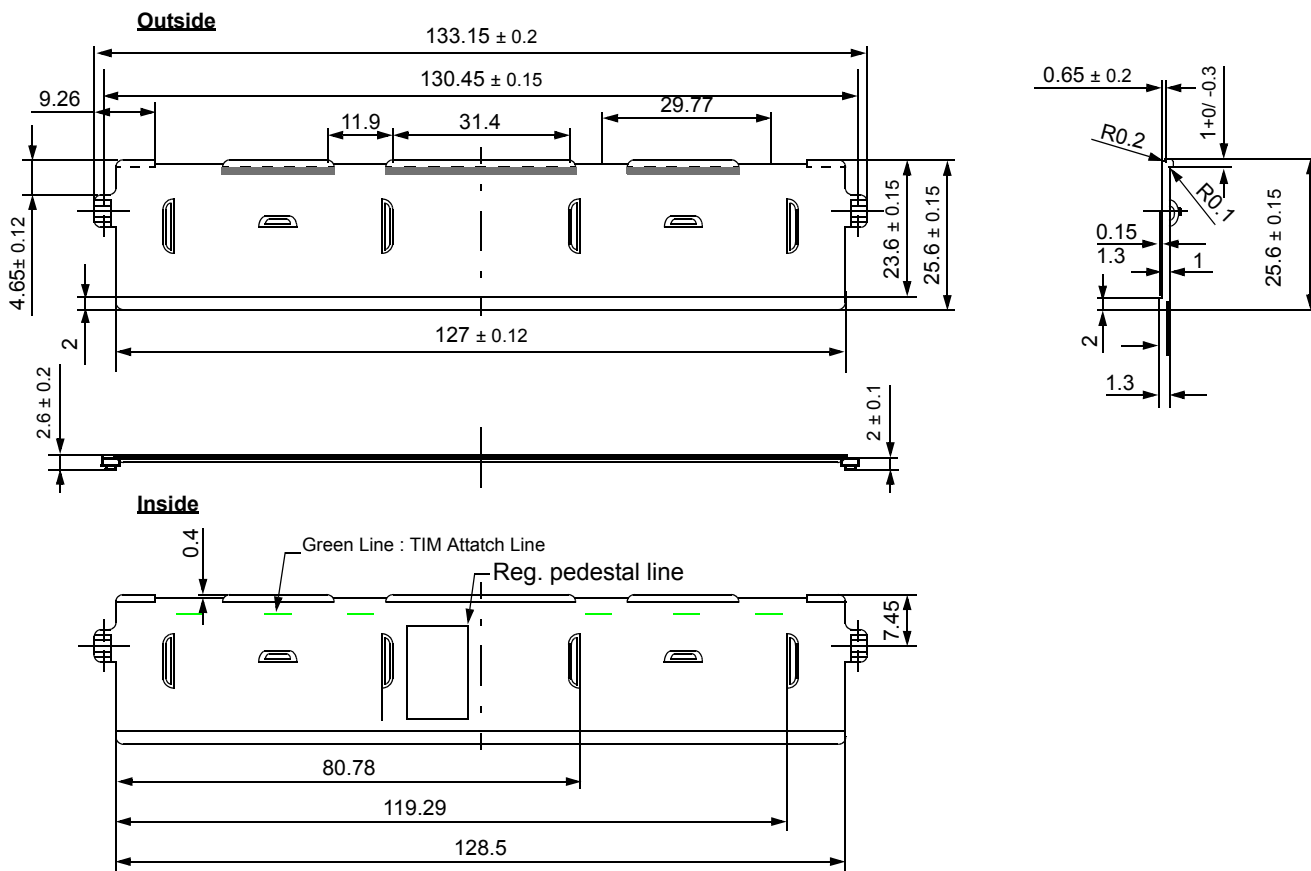

2. BACK PART

**Outside**

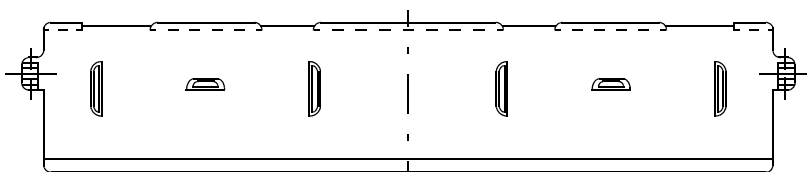

**Inside**

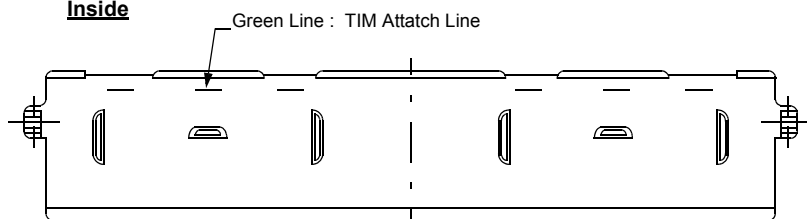

3. CLIP PART

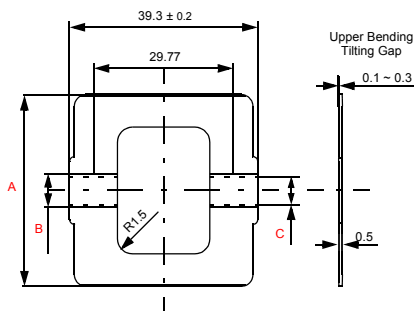

4. DDR3 RDIMM ASS'Y View

Reference thickness total (Maximum) : Mono Package : 7.55mm, DDP Package 7.71mm (With Clip thickness)

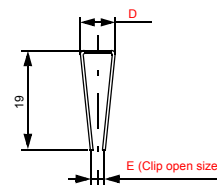
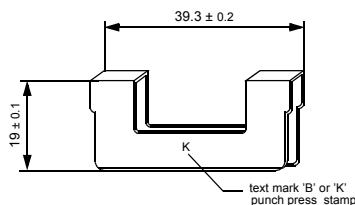
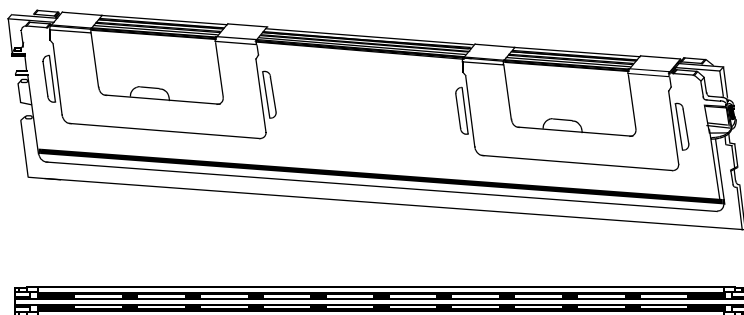
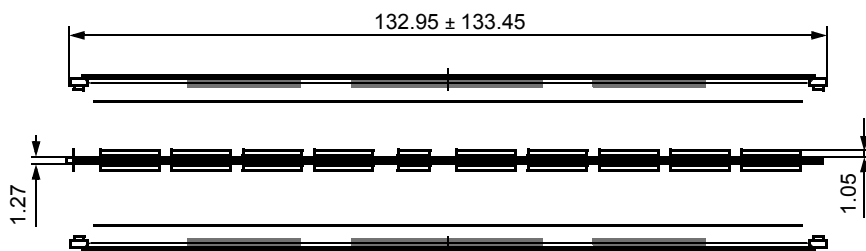

\* Dimension Index

	Mono			DDP			Note
	Min.	Typ.	Max.	Min.	Typ.	Max.	
<b>A</b>	-	43.9	-	-	44.4	-	
<b>B</b>	6.7	6.8	6.9	7.2	7.3	7.4	
<b>C</b>	-	5.8	-	-	6.3	-	
<b>D</b>	6.7	6.8	6.9	7.2	7.3	7.4	
<b>E (Clip open size)</b>	2.5	-	3.6	2.6	-	3.8	

## Free Manuals Download Website

<http://myh66.com>

<http://usermanuals.us>

<http://www.somanuals.com>

<http://www.4manuals.cc>

<http://www.manual-lib.com>

<http://www.404manual.com>

<http://www.luxmanual.com>

<http://aubethermostatmanual.com>

Golf course search by state

<http://golfingnear.com>

Email search by domain

<http://emailbydomain.com>

Auto manuals search

<http://auto.somanuals.com>

TV manuals search

<http://tv.somanuals.com>