

# S3F84B8

---

## All-in-One IH Cooker

Revision 0.00

May 2010

# Application Note

SAMSUNG ELECTRONICS RESERVES THE RIGHT TO CHANGE PRODUCTS, INFORMATION AND SPECIFICATIONS WITHOUT NOTICE.

Products and specifications discussed herein are for reference purposes only. All information discussed herein is provided on an "AS IS" basis, without warranties of any kind.

This document and all information discussed herein remain the sole and exclusive property of Samsung Electronics. No license of any patent, copyright, mask work, trademark or any other intellectual property right is granted by one party to the other party under this document, by implication, estoppel or otherwise.

Samsung products are not intended for use in life support, critical care, medical, safety equipment, or similar applications where product failure could result in loss of life or personal or physical harm, or any military or defense application, or any governmental procurement to which special terms or provisions may apply.

For updates or additional information about Samsung products, contact your nearest Samsung office.

All brand names, trademarks and registered trademarks belong to their respective owners.

© 2010 Samsung Electronics Co., Ltd. All rights reserved.

**SAMSUNG ELECTRONICS**

**SAMSUNG**

# Important Notice

The information in this publication has been carefully checked and is believed to be entirely accurate at the time of publication. Samsung assumes no responsibility, however, for possible errors or omissions, or for any consequences resulting from the use of the information contained herein.

Samsung reserves the right to make changes in its products or product specifications with the intent to improve function or design at any time and without notice and is not required to update this documentation to reflect such changes.

This publication does not convey to a purchaser of semiconductor devices described herein any license under the patent rights of Samsung or others.

Samsung makes no warranty, representation, or guarantee regarding the suitability of its products for any particular purpose, nor does Samsung assume any liability arising out of the application or use of any product or circuit and specifically disclaims any and all liability, including without limitation any consequential or incidental damages.

## **S3F84B8 All-in-One IH Cooker Application Note, Revision 0.00**

**Copyright © 2010 Samsung Electronics Co., Ltd.**

All rights reserved. No part of this publication may be reproduced, stored in a retrieval system, or transmitted in any form or by any means, electric or mechanical, by photocopying, recording, or otherwise, without the prior written consent of Samsung Electronics.

Samsung Electronics Co., Ltd.  
San #24 Nongseo-Dong, Giheung-Gu  
Yongin-City, Gyeonggi-Do, Korea 446-711

TEL: (82)-(31)-209-3865  
FAX: (82)-(31)-209-6494

Home Page: <http://www.samsungsemi.com>

"Typical" parameters can and do vary in different applications. All operating parameters, including "Typicals" must be validated for each customer application by the customer's technical experts.

Samsung products are not designed, intended, or authorized for use as components in systems intended for surgical implant into the body, for other applications intended to support or sustain life, or for any other application in which the failure of the Samsung product could create a situation where personal injury or death may occur.

Should the Buyer purchase or use a Samsung product for any such unintended or unauthorized application, the Buyer shall indemnify and hold Samsung and its officers, employees, subsidiaries, affiliates, and distributors harmless against all claims, costs, damages, expenses, and reasonable attorney fees arising out of, either directly or indirectly, any claim of personal injury or death that may be associated with such unintended or unauthorized use, even if such claim alleges that Samsung was negligent regarding the design or manufacture of said product.

# Revision History

Revision No.	Effective Date	Description	Refer to	Author(s)
0.00	Mar, 2010	- Initial Draft		Wei Ningning Zhang Fan

# Table of Contents

<b>1</b>	<b>OVERVIEW OF IH COOKER (IHC)</b> .....	<b>1-1</b>
1.1	Induction Cooking Principle .....	1-1
1.1.1	How Induction Cooking Works .....	1-1
1.2	Key Features of S3F84B8.....	1-2
1.3	System Principle .....	1-3
1.3.1	Heating .....	1-3
1.3.2	Protection.....	1-3
<b>2</b>	<b>HARDWARE IMPLEMENTATION</b> .....	<b>2-4</b>
2.1	System Diagram and pin Assignment.....	2-4
2.2	Power Supply .....	2-6
2.3	Synchronization Circuit .....	2-7
2.4	Power control .....	2-9
2.4.1	Voltage Measurement .....	2-9
2.4.2	Current Measurement.....	2-10
2.5	System Protection .....	2-11
2.5.1	Surge Protection .....	2-11
2.5.2	IGBT over Voltage Protection.....	2-11
2.5.3	Over/under Voltage Protection .....	2-11
2.5.4	Temperature Protection.....	2-12
2.6	Other Functions.....	2-13
2.6.1	Pan Detection .....	2-13
2.6.2	Buzzer and Fan Control.....	2-13
2.6.3	Key and Display Circuit .....	2-14
<b>3</b>	<b>SOFTWARE IMPLEMENTATION</b> .....	<b>3-1</b>
3.1	State Transition Diagram .....	3-1
3.2	Software Diagram .....	3-2
3.3	Internal Resource Arrangement and Configuration .....	3-4
<b>4</b>	<b>APPENDIX</b> .....	<b>4-1</b>
4.1	Error Code.....	4-1
4.2	Schmatic .....	4-1
4.3	Source Code .....	4-1

# List of Figures

Figure Number	Title	Page Number
Figure 1-1	How IH Cooker Works .....	1-1
Figure 1-2	Pin Assignment in S3F84B8 .....	1-2
Figure 2-1	Block Diagram of IH Cooker System .....	2-4
Figure 2-2	Power Supply Circuit .....	2-6
Figure 2-3	Power Supply Circuit .....	2-7
Figure 2-4	Waveform of the Synchronization Circuit .....	2-8
Figure 2-5	Voltage Measurement and Surge Protection Circuit .....	2-9
Figure 2-6	Current Measurement Circuit.....	2-10
Figure 2-7	Over-Temperature Protection .....	2-12
Figure 2-8	Buzzer and Fan Control.....	2-13
Figure 2-9	Key and Display Circuit.....	2-14
Figure 3-1	State Transition Diagram .....	3-1
Figure 3-2	Software Diagram .....	3-2
Figure 3-3	Interrupt Service Routine Diagram .....	3-3
Figure 3-4	Fan and BUZ Workflow.....	3-3

# List of Tables

<b>Table Number</b>	<b>Title</b>	<b>Page Number</b>
Table 2-1	S3F84B8 pin assignment in IH cooker system .....	2-5
Table 3-1	Internal Resource Arrangement and Configuration .....	3-4
Table 4-1	Error Information .....	4-1

# 1 OVERVIEW OF IH COOKER (IHC)

In traditional ranges or ovens, cookware is used to transfer heat from the stove elements. However, in the IH cooker (IHC), the cookware participates in the heat generation. This form of heat generation is known as Induction Heating, and it improves the overall thermal efficiency of heating.

This document describes an IH cooker (IHC) system implemented with Samsung's newly developed 8-bit MCU S3F84B8, which is designed for an all-in-one IHC application with amplifier and comparators.

## 1.1 INDUCTION COOKING PRINCIPLE

According to Faraday's Law, changing the magnetic field associated with an alternating current (AC) induces current in a second conductor placed in that field. IH cookers work largely the same way.

### 1.1.1 HOW INDUCTION COOKING WORKS

This section describes how induction cooking works.

#### Steps:

- 1) The electronic components in the element power a coil, which in turn produces a high-frequency electromagnetic field.
- 2) The electromagnetic field enters the ferrous metal (magnetic material) of the cookware and sets up a circulating electric current (Eddy current), which generates heat.
- 3) The heat generated in the cookware is transferred internally.
- 4) The electromagnetic field does not affect the outer body of cookware. As soon as the cookware is removed from the element or the element turned off, the heat generation stops.

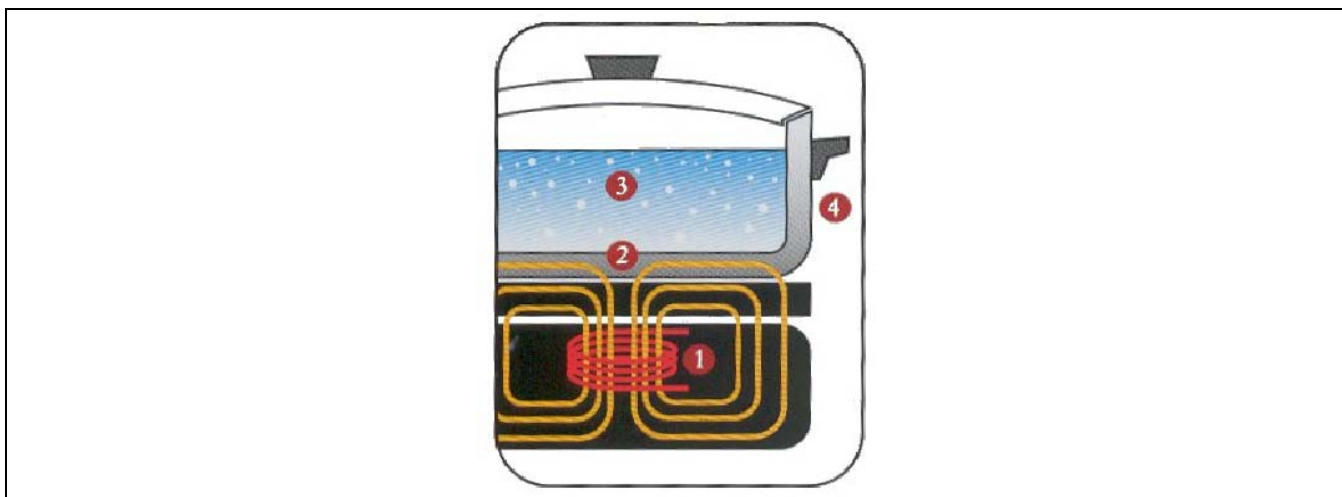

Figure 1-1 How IH Cooker Works

## 1.2 KEY FEATURES OF S3F84B8

With no more discrete ICs like LM339 (comparator IC) in previous IHC solutions, S3F84B8 successfully integrates four comparators, one OPA, and one IH-PWM to control power directly. After configuration, all the four comparators can cooperate with the IH-PWM automatically, which makes the time-sensitive control possible. Figure2 shows the pin assignment in S3F84B8.

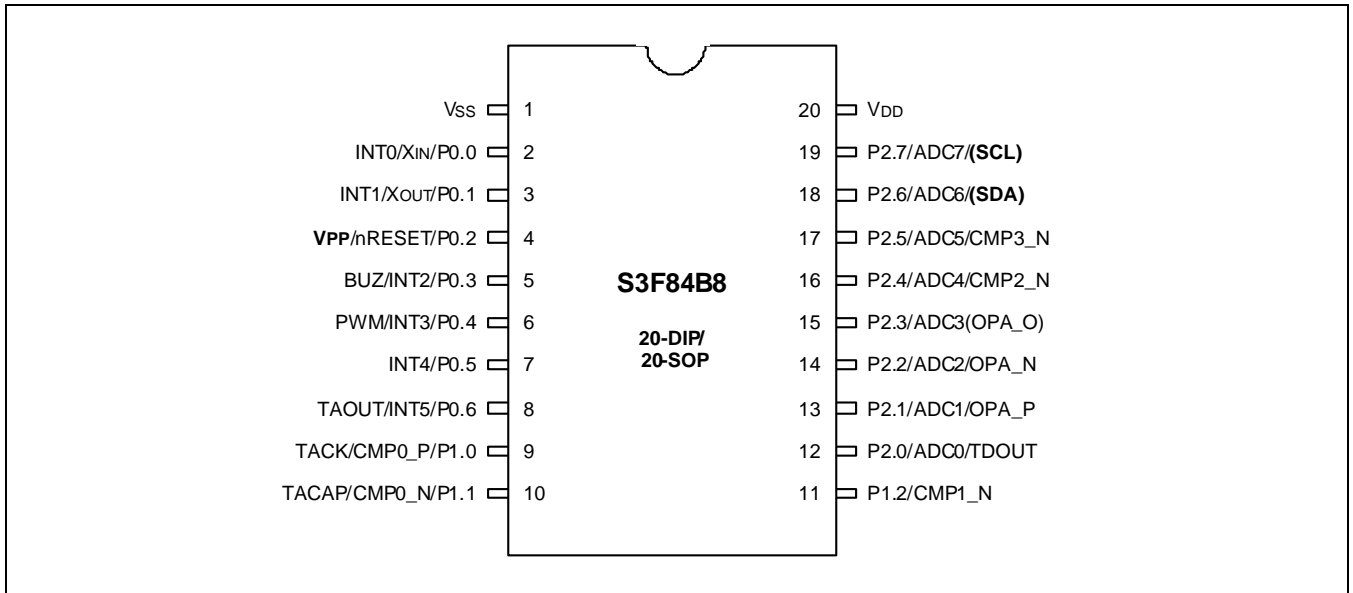

Figure 1-2 Pin Assignment in S3F84B8

The key features of S3F84B8 include:

- 8K Full Flash ROM and 272B SRAM
- Four Comparators
- One OPA
- 10-bit IH-PWM x 1 (can co-operate with the four Comparators)
- 10-bit ADC x 8
- 8-bit Basic Timer (can be used as Watch Dog Timer)
- 8-bit TimerA
- 16-bit Timer0 (can be used as two 8-bit Timers C/D)
- External Interrupts X 6
- Supports configurable LVR (1.9/2.3/3.6/3.9V)
- Supports configurable internal RC (0.5M/8MHz RC @5V with maximum 3% accuracy)
- Supports 18 IOs (maximum) when using internal LVR and internal RC

Comparator0 has two inputs. Its output can trigger the PWM to start a new cycle immediately or after some programmable delay. This helps in the synchronization control. The delay can adjust the IGBT to turn on at minimum collector voltage, thereby reducing the heat and protecting the transistor.



Comparator1/2/3 has only one input with an internal programmable reference level. It can lock the output of PWM to a safe level. Besides the delay trigger function, PWM can realize anti-mis-trigger function as well. It prevents the PWM from being triggered by unexpected noise. For more information about the cooperating mechanism of the IH-PWM and four comparators, refer to the user's manual.

## 1.3 SYSTEM PRINCIPLE

To make the system work reliably, the control of IH cooker can be divided into two major parts: heating and protection.

### 1.3.1 HEATING

In earlier solutions, the output of LM339 controls the IGBT. On being filtered, the PWM output transforms into an analog signal that sets the flip level of LM339. Therefore, only the duty determines the output power.

However, in a system with S3F84B8, the PWM directly controls the switch of IGBT and the width of valid output level determines the output power. Therefore, the power is dependent on the system clock.

### 1.3.2 PROTECTION

Two kinds of protection are available for the control of IH cooker: first is time sensitive protection, and the other is acceptable protection that can be executed even after certain degree of delay.

Surge protection and IGBT over-voltage protection belong to the former class (time sensitive protection).

Therefore, these two signals use the integrated comparators. In this solution, PWM will be hard-locked when surge protection is triggered. It stops the PWM with a safe output level until the software enables it again. Once the voltage sensed at IGBT is beyond limitation, PWM will be soft-locked. This will make the PWM stop the current cycle and reload PWMDATA with a preset safe value (PWMPDATA) to reduce the turn-on time of IGBT from that instance.

Over-temperature, over-current, and over/under voltage protections belong to the latter class. They are realized by AD conversion and software comparison.

# 2 HARDWARE IMPLEMENTATION

## 2.1 SYSTEM DIAGRAM AND PIN ASSIGNMENT

Figure 2-1 shows the block diagram of IH cooker system.

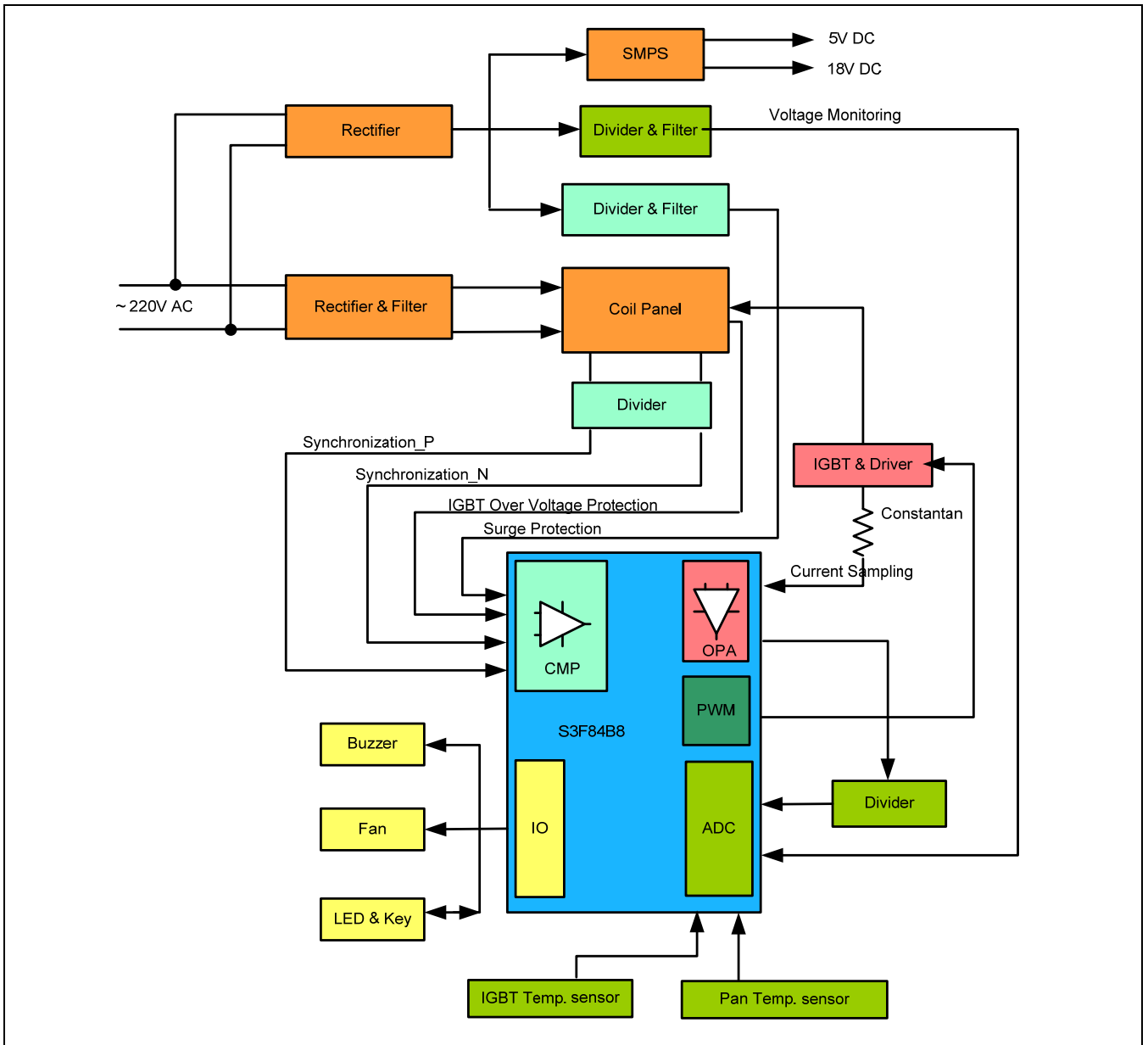

Figure 2-1 Block Diagram of IH Cooker System

In [Figure 2-1](#), SMPS stands for Switch Mode Power Supply. It provides +18V DC and +5V DC to the system. Three out of four comparators are used in this solution: one for synchronization circuit and other two for surge protection and IGBT over-voltage protection.

[Table 2-1](#) shows the pin assignment while using S3F84B8 in IH cooker system.

**Table 2-1 S3F84B8 pin assignment in IH cooker system**

Pin No.	Pin Names	Pin Type	Pin Assignment	
1	VSS	I	Ground	
20	VDD	I	Power input	
4	P0.2	-	Reserved	
2	P0.0	O	Display Board Connector	DIO
3	P0.1	O		CLK
7	P0.5	O		STB
8	P0.6	O	Reserved	
13	P2.1	O	Reserved	
5	P0.3/BUZ	O	Buzzer and Fan control	
6	P0.4/PWM	O	IGBT control	
9	P1.0/CMP0_P	I	Synchronization control	
10	P1.1/CMP0_N	I		
11	P1.2/CMP1_N	I	IGBT over-voltage protection	
16	P2.4/CMP2_N	I	Surge protection	
17	P2.5/ADC5	I	System voltage measurement input	
12	P2.0/ADC0	I	IGBT temperature sensor input	
19	P2.7/ADC7	I	Pan temperature sensor input	
18	P2.6/ADC6	I	Amplified current signal input	
14	P2.2/OPA_N	I	System current measurement input	
15	P2.3/OPA_O	O	Operational Amplifier output	

## 2.2 POWER SUPPLY

[Figure 2-2](#) shows the circuit diagram for power supply.

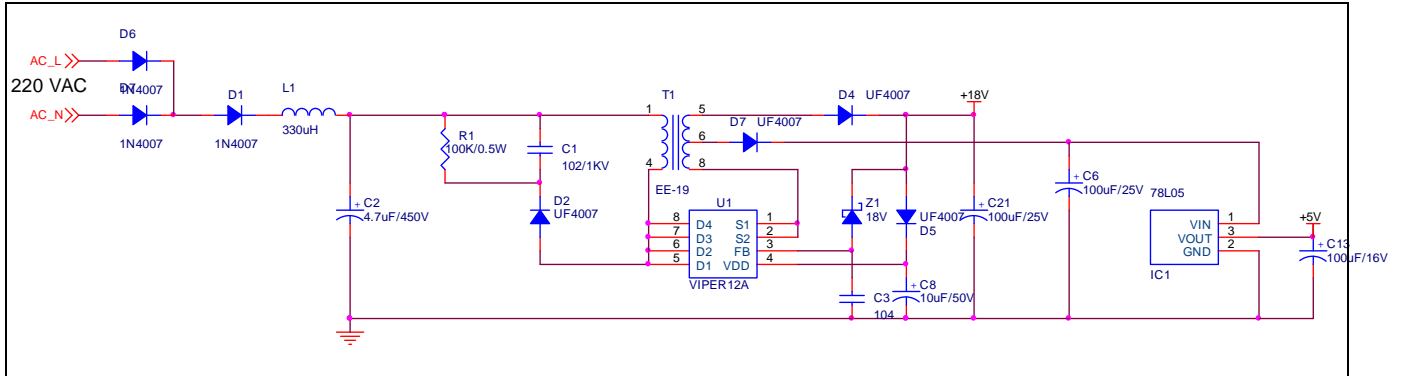

**Figure 2-2 Power Supply Circuit**

The power circuit contains a transformer, an SMPS primary switcher, and a +5V DC regulator. After passing through a half-wave rectifier and an LC filter, the 220V AC power enters the primary side of transformer. Thereafter, VIPER12 and 78L05 produce stable +18V DC power for the transistors and +5V DC power for the MCU and other devices.

### 2.3 SYNCHRONIZATION CIRCUIT

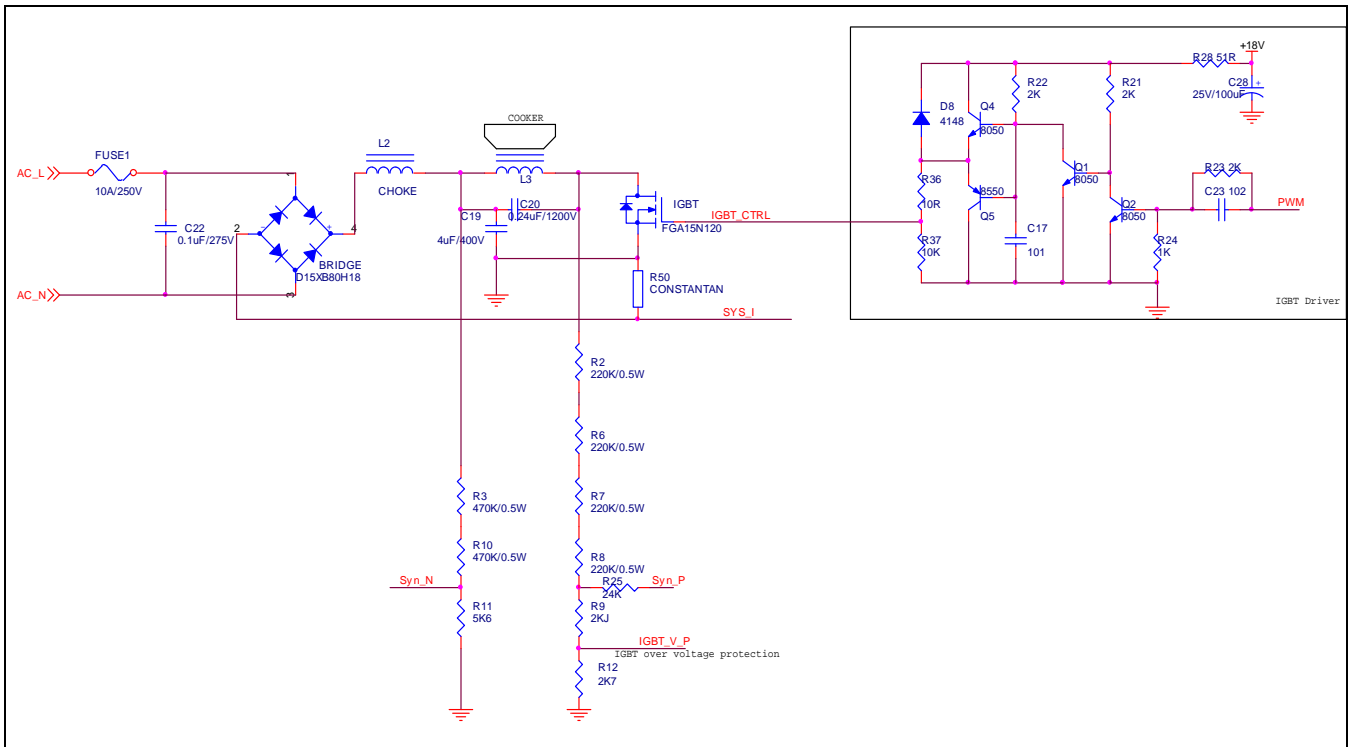

Figure 2-3 Power Supply Circuit

IH heating is the result of Eddy current caused by LC resonance. For a general cookware, the oscillation frequency may vary from 20KHz to 30KHz. Since heating consumes energy, the IGBT should be periodically turned on to allow the 220V power to compensate for the energy loss. Obviously, the longer it is turned on, the more energy can be accumulated.

When the PWM output turns on the IGBT, electric energy is stored in the inductance and free LC oscillation is started when the IGBT is turned off (as shown in Figure 2-3).

To make the system work stably, consider the turn on frequency and turn on time of the IGBT. First, the turn on frequency cannot destroy the LC oscillation, even though the IGBT on time will affect it a little bit. This means the frequency of PWM output should be synchronized with the LC oscillation. It is realized by comparator0.

Second, considering the withstand voltage of IGBT, it is better to turn it on when the collector voltage is near '0'. It can be realized by adjusting the divider resistors and enabling the delay trigger function of the IH PWM module. At the same time, when proper delay time is set, thermal radiations will be largely reduced.

Figure6 shows the waveform of synchronization circuit. Light and dark blue waveforms show the inputs of comparator0. The green waveform is measured at P0.4 (PWM). Additionally, the crossing point of the light and dark blue waveforms trigger the rising of PWM output (High level at the base) which turns on the IGBT. The duration of PWM's outputting high is the result of software power control. When PWM output (green waveform) returns to low level, the light and dark waveform presents free oscillation of the circuit, though the existence of the IGBT diode makes the oscillation waveform not an ideal one.

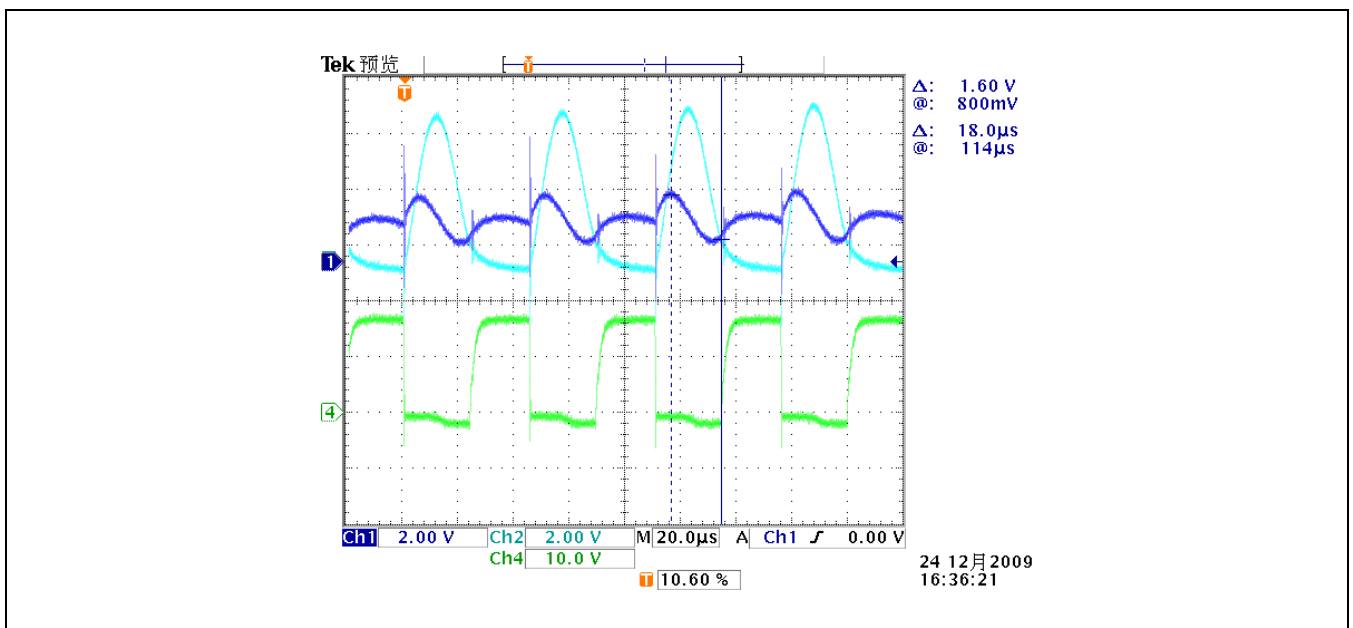

Figure 2-4 Waveform of the Synchronization Circuit

## 2.4 POWER CONTROL

Power is the product of voltage and current ( $P = V \times I$ ). Figure 2-5 and [Figure 2-6](#) show the measurement circuit of system voltage and current, separately.

### 2.4.1 VOLTAGE MEASUREMENT

[Figure 2-5](#) shows the circuit diagram for voltage measurement and surge protection.

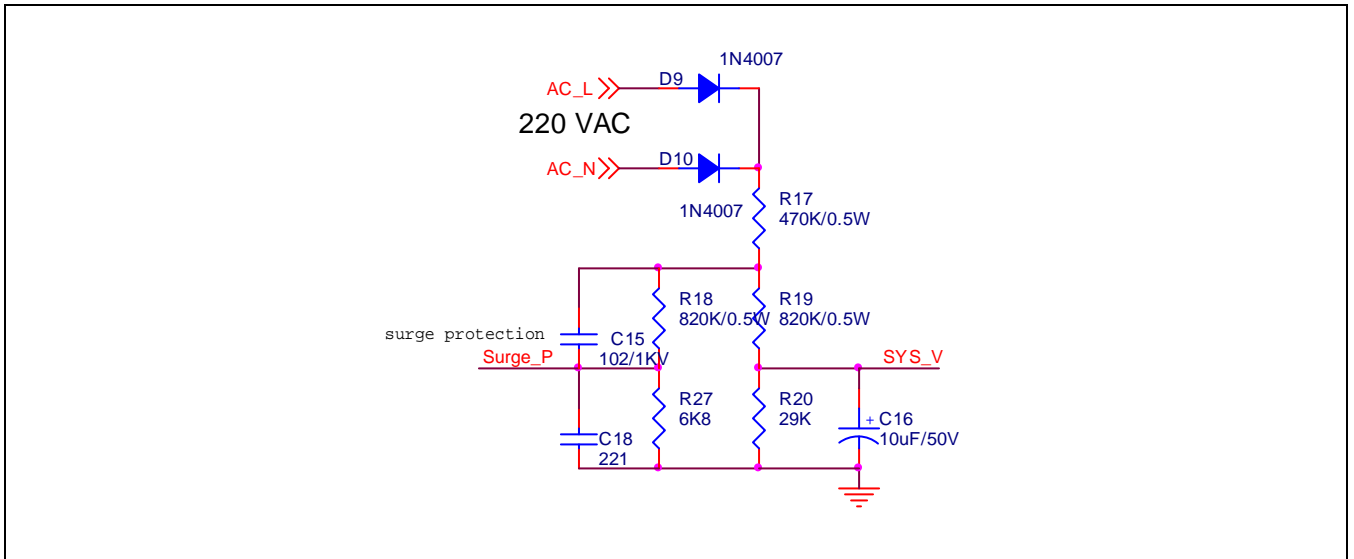

**Figure 2-5 Voltage Measurement and Surge Protection Circuit**

Resistor divider decreases the voltage level to the proper ADC range.

## 2.4.2 CURRENT MEASUREMENT

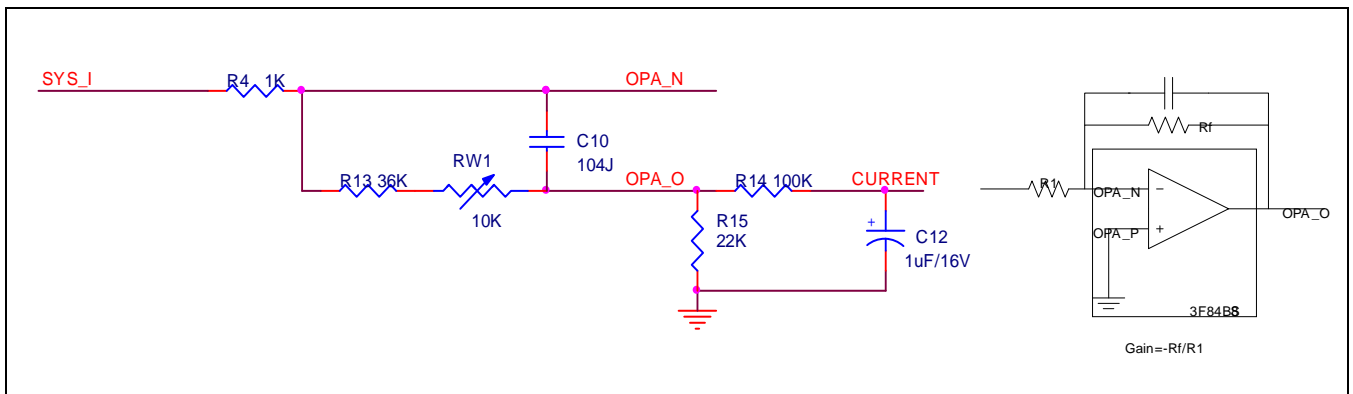

**Figure 2-6 Current Measurement Circuit**

In the IH cooker system, the current can go as high as 10A. To avoid excessive energy loss, a constantan is used to change the current signal to voltage signal, which is then amplified by the integrated OPA. Finally, the amplified signal enters the ADC module. Note that the signal (OPA\_N) reaching OPA is negative as compared to MCU GND. Therefore, OPA has to work as an inverting amplifier with negative gain.

Either the OPA offset or the resistance deviation can lead to inconsistency of output power among different chips. To get precise power control, two calibrating methods are used. In hardware, a variable resistor (RW1) is chosen, whereas in software algorithm, the overall offset is measured and calculated before the system starts working. It likes the quiescent bias that should be removed during normal operation. This way the output power can be controlled within 10W deviation.



## 2.5 SYSTEM PROTECTION

### 2.5.1 SURGE PROTECTION

[Figure 2-5](#) shows the circuit diagram for surge protection. In this figure, Surge\_P specifies the negative input of Comparator 1. Also, reference voltage is internally set as 0.55VDD. When surge takes place, that is,  $V_{\text{Surge\_P}} > 0.55VDD$ , the falling edge of comparator 1 can hard-lock the PWM output immediately to prevent the IGBT from being burnt out by over current. The whole system then stops work and restarts after some delay.

### 2.5.2 IGBT OVER VOLTAGE PROTECTION

IGBT over voltage is most likely to occur the moment when the pan is removed from the panel.

[Figure 2-5](#) shows the voltage measurement circuit. In this figure, IGBT\_V\_P specifies the negative input of Comparator 2. Also, reference voltage internally is set as 0.70VDD. When  $V_{\text{Surge\_P}} > 0.70VDD$ , the co-operation of comparator 2 and IH PWM will soft-lock the PWM output immediately to prevent the IGBT from being burnt out by over stress of the collector voltage. As a result, it makes the PWM stop the current cycle and reload PWMDATA with a preset safe value (PWMPDATA) to reduce the turn-on time of IGBT.

### 2.5.3 OVER/UNDER VOLTAGE PROTECTION

Over/under voltage protection uses the voltage measurement signal. The protection takes place when the AD conversion result is either too large or too small. The whole system then stops working until the power returns to normal.

## 2.5.4 TEMPERATURE PROTECTION

[Figure 2-7](#) shows the circuit diagram for temperature protection.

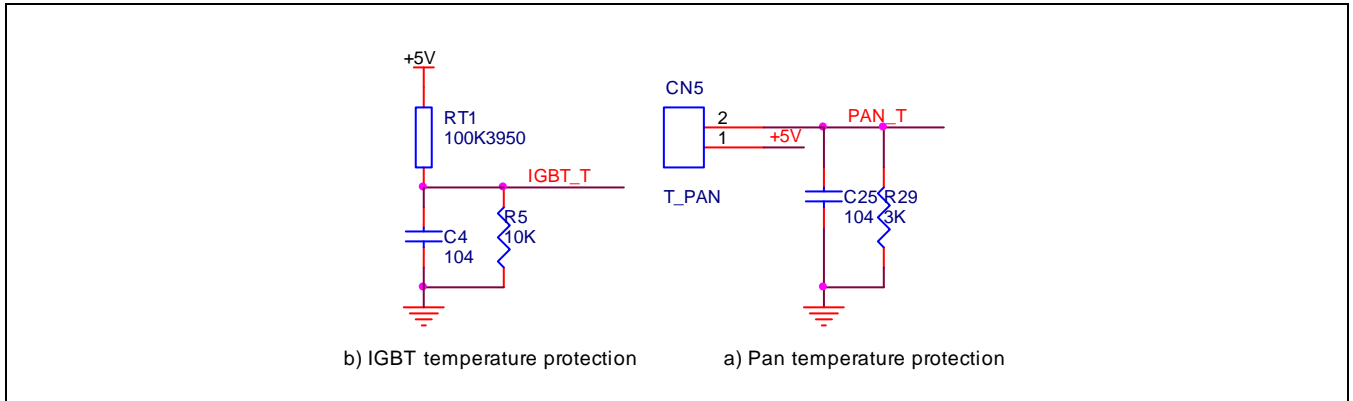

**Figure 2-7 Over-Temperature Protection**

RT1 is a thermistor located just beneath the IGBT. CN5 is the connector for the thermistor near the pan.

For IGBT temperature protection, there are two kinds of scenarios:

- When the temperature rises above 85 °C, the set level of output power will automatically downgrade.
- When the temperature continues to rise above 90 °C, the system will shut down and will remain in that state until it is restarted manually.

For pan temperature, the system will be shut down when the temperature is over 230 °C.

The threshold of protection level can differ, according to the different locations of the thermistor.

Meantime, when the sensed voltage level is close to 5V or 0V, the sensor can be viewed as broken. The whole system then stops working until it is restarted manually.

## 2.6 OTHER FUNCTIONS

### 2.6.1 PAN DETECTION

Pan-on detection is executed every 2sec when the system is idle. It is useful when you press the Start key first and then put the pan on. In principle, even though the IGBT is turned on, there will not be any oscillation before the pan is put on the panel. In S3F84B8, comparator 0's output can be set as the clock source of Timer C. After starting 1-cycle PWM output and waiting for about 3 oscillation cycles, if  $TCCNT > 1$ , Pan status = on; else Pan status = off. Pan-remove detection is executed every 1.5s when the system is working. It is useful when you directly remove the pan from the panel without pressing the Stop key.

Pan-remove detection is done by current measurement, that is, when the sensed current is small, the system considers the pan as removed and turns idle.

### 2.6.2 BUZZER AND FAN CONTROL

[Figure 2-8](#) shows the circuit diagram for buzzer and fan control.

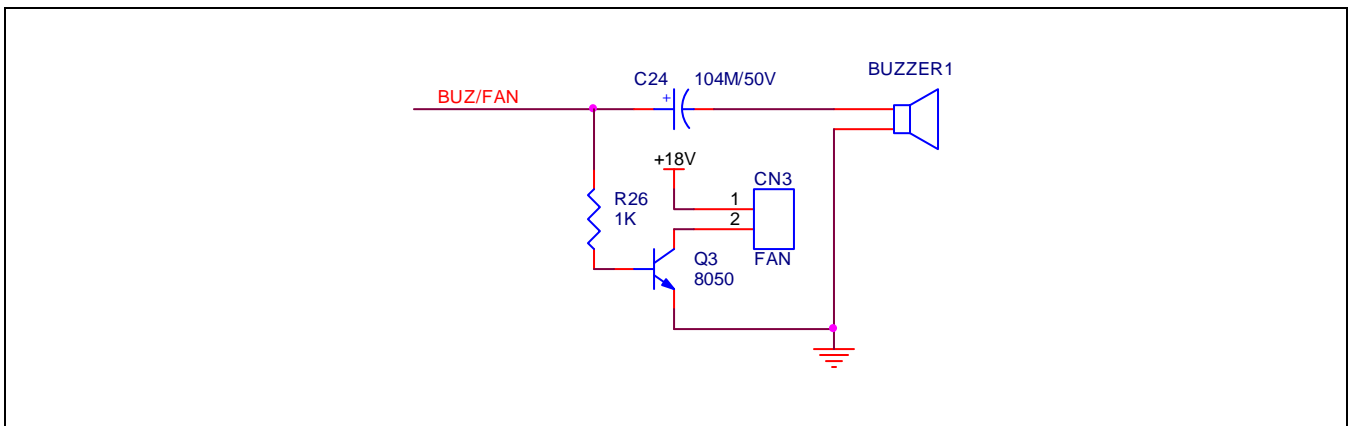

**Figure 2-8 Buzzer and Fan Control**

The fan cools down the system while heating. Buzzer indicates error and key actions.

In [Figure 2-8](#), buzzer and fan share the same I/O. Due to C24, the DC signal controls fans on and off, while square wave with high frequency determines the buzzer's beep.

Note that C24 cannot be too large; else it will deteriorate the power of MCU and make the integrated analog modules work unstably.

2.6.3 KEY AND DISPLAY CIRCUIT

Figure 2-9 shows the circuit diagram for key and display.

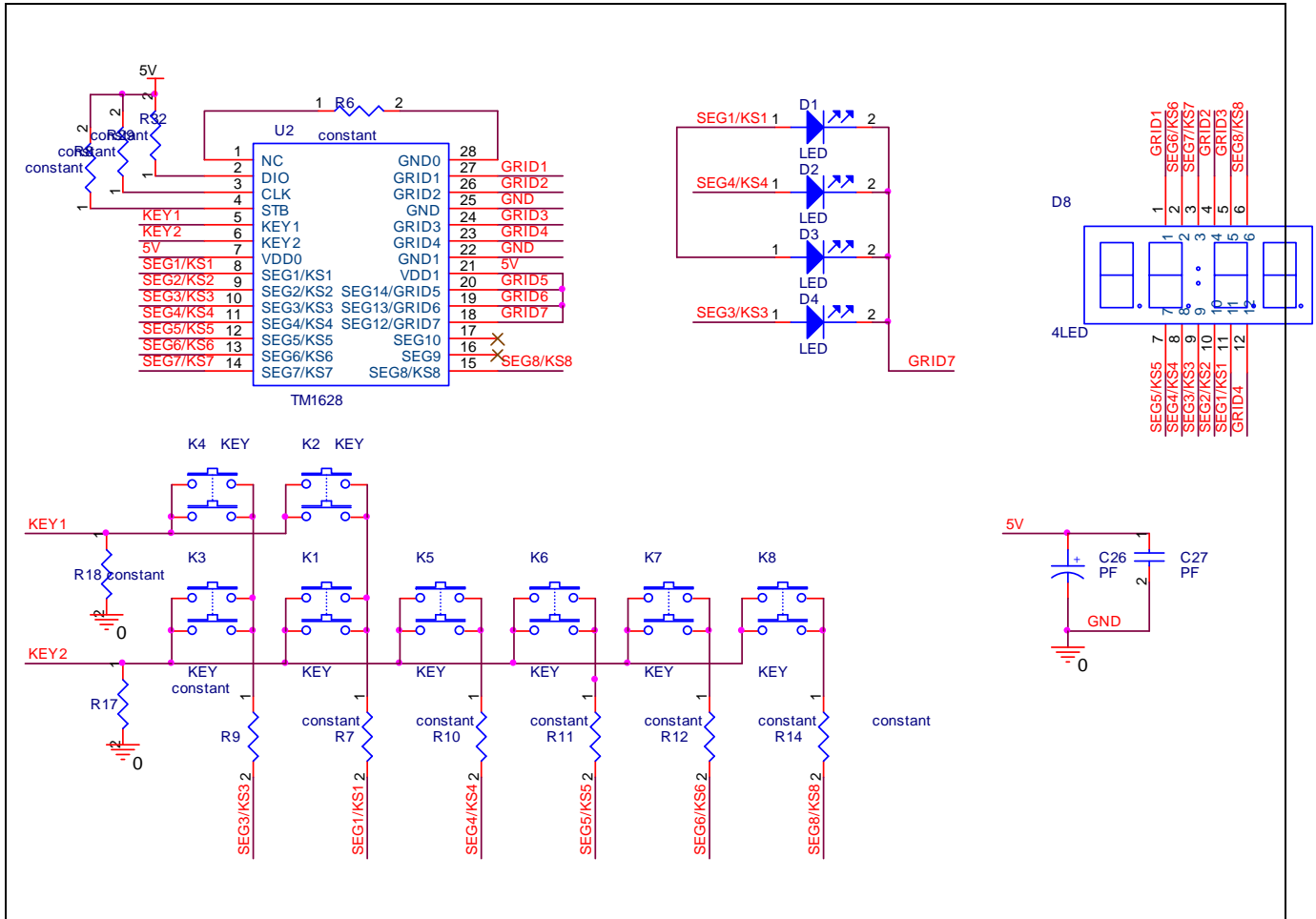

Figure 2-9 Key and Display Circuit

There are eight keys for power on, power grade selection, and some LEDs to display the operating status and power grade. TM1628 controls the key and display circuit. MCU communicates with TM1628 through three I/Os: DIO for data transfer, CLK as serial clock, and STB for chip enable.

# 3

## SOFTWARE IMPLEMENTATION

### 3.1 STATE TRANSITION DIAGRAM

[Figure 3-1](#) shows the state transition diagram. This diagram illustrates the operation of IH cooker system.

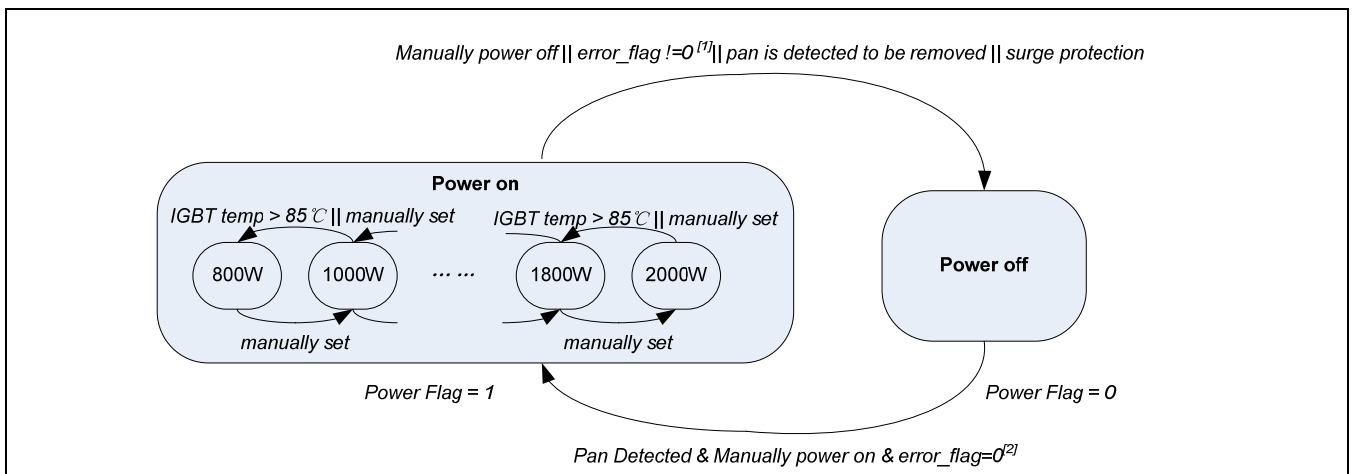

**Figure 3-1 State Transition Diagram**

After power is turned on manually, the system periodically checks for pan status and current work condition. This ensures the power is activated only when the pan is on panel, and all temperatures and voltage are in good condition.

The IH cooker will stop heating immediately in case of the following issues:

- Manually power off by key pressing
- Error flag set as temperature or voltage is abnormal
- Pan is detected to be removed
- Surge protection is triggered

Note that only voltage recovery can reset the error flag to '0' and restart the system, which means once the error flag is set by IGBT/Pan over-temperature, you have to restart the system manually.

In the power on state, key pressing can alter the power. For reliability, the power will automatically downgrade when the IGBT temperature is higher than 85°C.

## 3.2 SOFTWARE DIAGRAM

Figure 3-2 shows the software diagram.

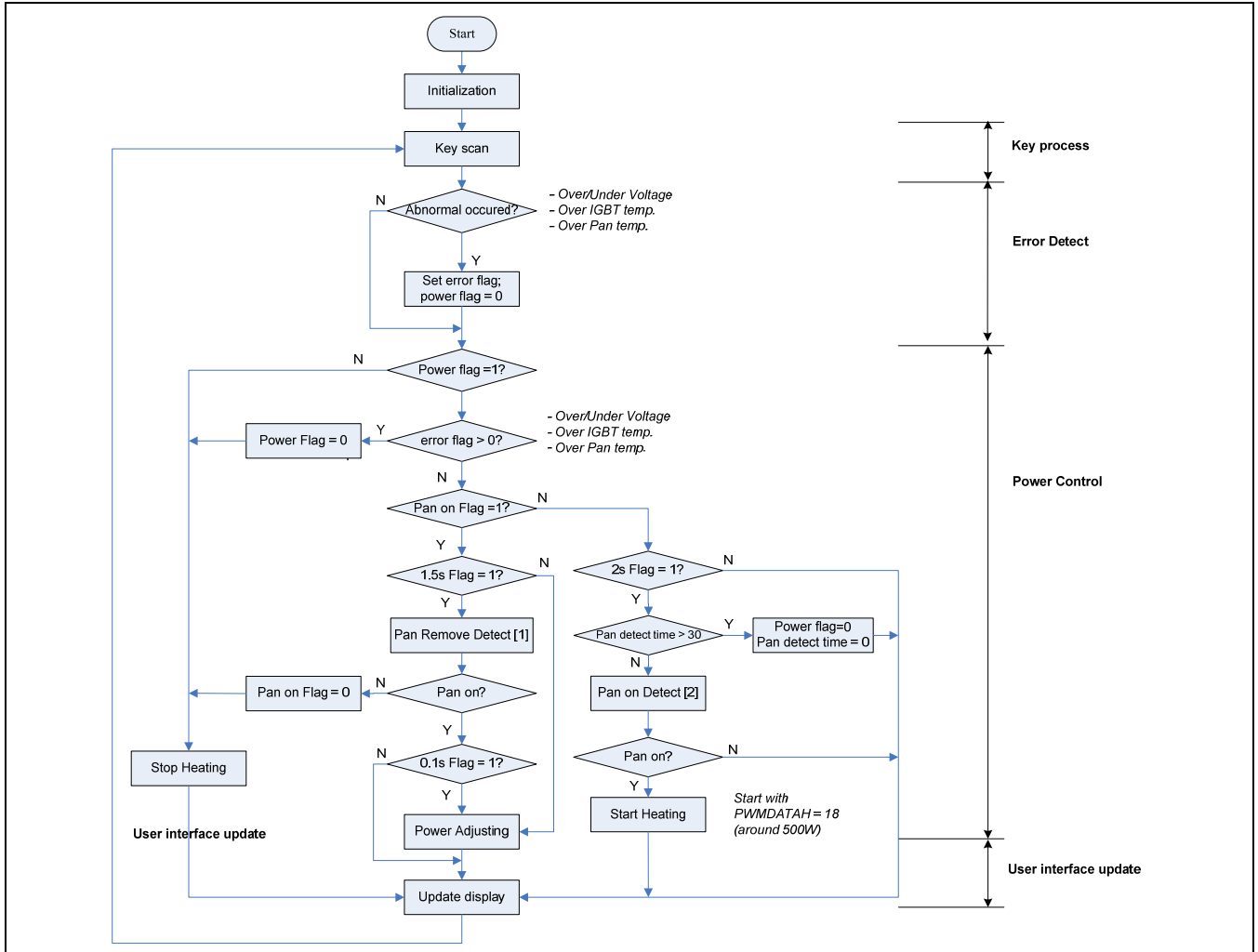

Figure 3-2 Software Diagram

### NOTE:

- [1] Pan remove detection [1] is done by current sensing. The pan is judged to be removed when the current is lower than a preset threshold.
- [2] Pan on detection [2] is done by pulse counting. The pan is judged to be put on when the counted pulse number is between 1 and 3 during 3 oscillation period.

Basic procedures include key process, error detection, power control, and UI update. These procedures are executed as an infinite loop. Most of the processes are controlled by timing. In other words, process is executed only when the corresponding timing flag is set. For example, 16 times AD conversion time for error detection, 1.5 second for pan-on detection, and 2 seconds for pan-remove detection.

Meanwhile, comparator1 and comparator2's interrupts are enabled for surge protection and IGBT over-voltage protection, separately. Therefore, the above procedure might be interrupted whenever any of the comparator 1 or comparator 2's interrupt condition is met.

Figure 3-3 shows the flow chart of CMP1/2 interrupt service routine. Due to the cooperation of IH-PWM and comparators integrated in S3F84B8, only a few jobs need to be done in the ISR.

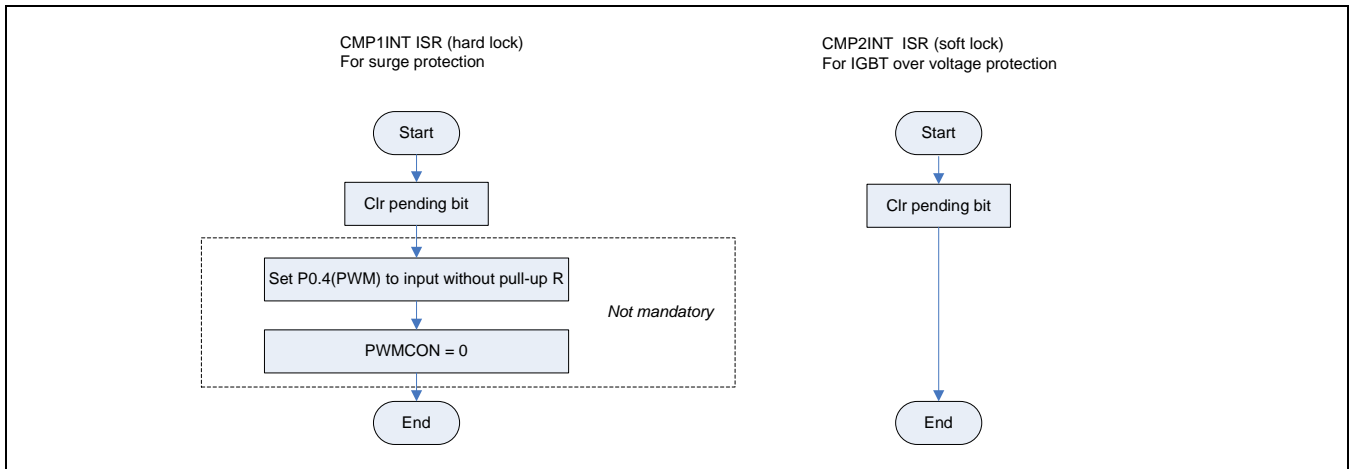

Figure 3-3 Interrupt Service Routine Diagram

**NOTE:** When hard lock happens, the PWM returns to the safe value immediately. When soft lock happens. The PWM returns to the safe value immediately for the current PWM cycle. And the PWMDATA will be reloaded as PWMPDATA, usually a smaller one, from the next cycle on.

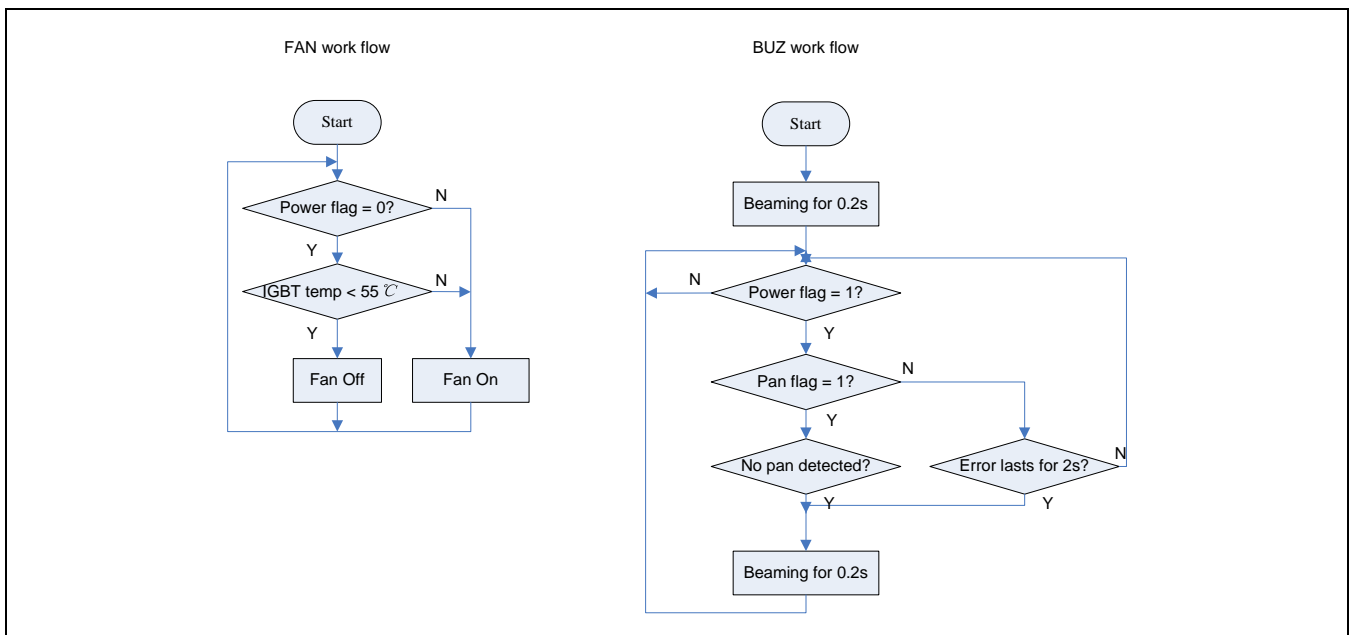

Figure 3-4 Fan and BUZ Workflow

Figure 3-4 shows the workflow of FAN and BUZ. FAN is always on as the IH cooker is generating heat. Even when the device is powered off by manually setting or system protection, it is still on as long as the IGBT temperature is higher than 55 °C, in order to prevent the cooker from hot temperature damage.

Buzzer is mainly used for information indication. Besides the first beaming at power on, it only gives alarm when some error lasts for 2sec or no pan is detected after trying 30 times

### 3.3 INTERNAL RESOURCE ARRANGEMENT AND CONFIGURATION

[Table 3-1](#) shows the internal resource arrangement and configuration.

**Table 3-1 Internal Resource Arrangement and Configuration**

Module	Purpose	Configuration	Registers
CMP0	Synchronization	Non-inverting output Disable INT	CMP0CON CMPINT P1CON
CMP2	Surge protection	0.50VDD reference Non-inverting output Enable INT	CMP1CON CMPINT P1CON
CMP1	IGBT over-V protection	0.65VDD reference, Non-inverting output, Enable INT	CMP2CON CMPINT P1CON
OPA	Current amplification	On-chip mode	OPACON P2CONL
PWM	IGBT control	Co-operate with CMP0 Delay Trigger AMT Trigger	PWMCON PWMCCON PWMDATAH/L PWMPDATAH/L P0CONH
BUZ	BUZ control	1KHz output	BUZCON P0CONL
TA	100ms timing for 1) BUZ beaming time (0.2sec for every enable) 2) Display blink interval (0.5sec) 3) Error warning (BUZ) after error lasts for 2sec 4) Pan-on detect every 2sec 5) Move pan detect every 1.5sec 6) Power adjust every 0.1sec 7) Check sensor status after 3min of heating up	Internal mode Match Interrupt Enable TA Internal Clock = Fosc/4096	TAPS TACON
TC	Pulse counting for pan detection	Interval mode Interrupt Disable TC clock = CMP0_O	TCCON TCPS

[Table 3-1](#) shows the internal resource arrangement for IH cooker system and related registers in S3F84B8. For detail description of all the registers and co-operation ways of comparators and IH PWM, refer to the S3F84B8 user's manual.



# 4 APPENDIX

## 4.1 ERROR CODE

[Table 4-1](#) shows the error information along with the error type and its code on 7seg-LED.

**Table 4-1 Error Information**

Error Type	Error code on 7seg-LED
IGBT temperature sensor error	E1
Pan temperature sensor error	E2
Over voltage error	E3
Under voltage error	E4
IGBT over temperature error	E5
Pan over temperature error	E6

## 4.2 SCHMATIC



S3F84B8\_DEMO\_V0.0  
\_0401.pdf

## 4.3 SOURCE CODE

For more information about the source code, refer to the Source\_Code\_IHC\_S3F84B8\_V00.

Reference:

[1] <http://theinductionsite.com/how-induction-works.shtml>

[2] S3F84B8 UM

## Free Manuals Download Website

<http://myh66.com>

<http://usermanuals.us>

<http://www.somanuals.com>

<http://www.4manuals.cc>

<http://www.manual-lib.com>

<http://www.404manual.com>

<http://www.luxmanual.com>

<http://aubethermostatmanual.com>

Golf course search by state

<http://golfingnear.com>

Email search by domain

<http://emailbydomain.com>

Auto manuals search

<http://auto.somanuals.com>

TV manuals search

<http://tv.somanuals.com>