

**SAMSUNG**

# **Laser Facsimile**

**User's Guide**

## **Msys 6750**



## **Trademarks**

- Windows is a trademark of Microsoft Corporation.
- IBM is a trademark of International Business Machines.
- Centronics is a trademark of Centronics Data Computer.
- Other names and trademarks mentioned in this manual are trademarks of their respective holders.

# Contents

## Chapter 1 Getting Started

---

<b>Setting up your machine</b> .....	1.2
Unpacking .....	1.2
Control locations and functions .....	1.3
Front view .....	1.3
Rear view .....	1.4
Inside .....	1.4
Choosing a location .....	1.5
Setting up your machine .....	1.5
Installing the toner cartridge .....	1.5
Loading paper into the cassette .....	1.8
To load a stack of paper .....	1.8
How to adjust paper guides .....	1.11
Manually feeding paper .....	1.13
Guidelines for the paper .....	1.14
Telephone line .....	1.15
Extension phone .....	1.15
AC power cord .....	1.16
Document tray .....	1.16
Document exit tray .....	1.17
Printer exit tray .....	1.17
System setup .....	1.18
Ringer volume .....	1.18
Home resolution and home contrast .....	1.18
Sound control .....	1.20
Remote diagnosis protection .....	1.20
Select language .....	1.21
Econo mode setting .....	1.21
Adjusting speaker volume .....	1.22
Setting the date and time .....	1.22
Setting the system ID (Your number and name) .....	1.23

## Chapter 2

# Operation

Using the control panel _____	2.2
Using the number keypad _____	2.4
Entering alphanumeric characters _____	2.4
Entering numbers _____	2.6
Editing numbers or names _____	2.6
Inserting pause _____	2.6
<b>Sending a fax _____</b>	<b>2.7</b>
Preparing documents for faxing or copying _____	2.7
Setting document resolution and contrast _____	2.8
Resolution _____	2.8
Contrast _____	2.8
Loading document _____	2.9
Sending a fax automatically _____	2.10
Canceling transmission _____	2.10
Confirming transmission _____	2.10
Automatic redial _____	2.11
Voice request _____	2.11
Sending a voice request _____	2.11
Answering a voice request _____	2.11
Delayed transmission _____	2.12
Memory transmission (Broadcasting) _____	2.14
Priority transmission _____	2.15
Adding documents to a standby operation _____	2.16
Canceling a standby operation _____	2.16
<b>Receiving a fax _____</b>	<b>2.17</b>
Receiving modes _____	2.17
Receiving automatically in FAX mode _____	2.18
Receiving automatically in TEL/FAX mode _____	2.18
Receiving automatically in ANS/FAX mode _____	2.19
Receiving manually in TEL mode _____	2.19
Receiving a fax when the machine is out of paper _____	2.20
Distinctive ring pattern detection (DRPD) _____	2.20

Mail box _____	2.21
Confidential transmission _____	2.21
Setting up mail box for confidential receiving _____	2.23
Printing received confidential document _____	2.24
Polling _____	2.25
What is polling? _____	2.25
Being polled by a remote machine (TX poll) _____	2.25
Adding documents to the job to be polled _____	2.26
Canceling a job already in memory which is waiting to be polled _____	2.27
Polling one or more remote machines (RX poll) _____	2.27
<b>Making a copy</b> _____	2.29
Making a copy _____	2.29
<b>Automatic dialing</b> _____	2.31
One-touch dialing _____	2.31
Storing a number for one-touch dialing _____	2.31
Using a one-touch number _____	2.32
Using one-touch label _____	2.32
Speed dialing _____	2.33
Storing a number for speed dialing _____	2.33
Using a speed number _____	2.33
Group dialing (for multi-address transmission) _____	2.34
Storing one-touch or speed dial numbers for group dialing _____	2.34
Editing one-touch dial or speed dial numbers in a group dial _____	2.35
Assigning a group to a one-touch button _____	2.36
Using group dialing (multi-address transmission) _____	2.36
Searching for a number in memory _____	2.37
Searching sequentially through memory _____	2.37
Searching by the first letter _____	2.37

## Chapter 2

## Operation (Continued)

<b>Other functions</b> _____	2.38
Using function buttons _____	2.38
Redial _____	2.38
Flash _____	2.39
Status _____	2.39
Printing reports _____	2.40
User options _____	2.41
Setting an option _____	2.41
Selectable options _____	2.42
Maintenance _____	2.47
Cleaning drum _____	2.47
Adjust shading _____	2.47
Notify toner Low _____	2.48

## Chapter 3

## Troubleshooting

<b>Troubleshooting</b> _____	3.2
Clearing jams _____	3.2
Document jams while sending a fax _____	3.2
Paper jams while the machine is printing _____	3.3
Tips for avoiding paper jams _____	3.5
LCD error messages _____	3.6
Fixing problems _____	3.8
Fax problems _____	3.8
 <b>Maintenance</b> _____	 3.10
Clearing memory _____	3.10
Cleaning the document scanner _____	3.11
Managing toner cartridge _____	3.13
Expected cartridge life _____	3.13
Replacing toner cartridge _____	3.13

## **Appendix**

FCC regulations -----	4.2
Canadian radio interference regulations -----	4.2
EC declaration of conformity -----	4.3
Laser safety statement -----	4.4
Safety information -----	4.5
Power saver -----	4.6
Specifications -----	4.7
Index -----	4.8

# Important Precautions and Safety Information



When using this fax machine, these basic safety precautions should always be followed to reduce risk of fire, electric shock, and injury to persons:

1. Read and understand all instructions.
2. Use common sense whenever operating electrical appliances.
3. Follow all warnings and instructions marked on the product and in the literature accompanying the product.
4. If an operating instruction appears to conflict with safety information, heed the safety information. You may have misunderstood the operating instruction. If you cannot resolve the conflict, contact your sales or service representative for assistance.
5. Unplug the fax machine from the AC wall socket and telephone jack before cleaning. Do not use liquid or aerosol cleaners. Use only a damp cloth for cleaning.
6. Do not place the fax machine on an unstable cart, stand, or table. It may fall, causing serious damage.
7. Your fax machine should never be placed on, near, or over a radiator, heater, air conditioner, or ventilation duct.
8. Do not allow anything to rest on the AC power, telephone, or PC interface cords. Do not locate your fax machine where the cords will be abused by persons walking on them.
9. Do not overload wall outlets and extension cords. This can diminish performance, and may result in the risk of fire or electric shock.
10. Do not allow pets to chew on the AC power, telephone, or PC interface cords.
11. Never push objects of any kind into the fax machine through case or cabinet openings. They may touch dangerous voltage points, creating a risk fire or shock. Never spill liquid of any kind onto or into the fax machine.
12. To reduce the risk of electric shock, do not disassemble the fax machine. Take it to a qualified service technician when repair work is required. Opening or removing covers may expose you to dangerous voltages or other risks. Incorrect reassembly could cause electric shock when the unit is subsequently used.
13. Unplug the machine from the telephone jack, PC, and AC wall outlet, and refer servicing to qualified service personnel under the following conditions:
  - When any part of the power cord, plug, or connecting cable is damaged or frayed.
  - If liquid has been spilled into the product.
  - If the product has been exposed to rain or water.
  - If the product does not operate properly after instructions have been followed.
  - If the product has been dropped, or the cabinet appears damaged.
  - If the product exhibits a sudden and distinct change in performance.
14. Adjust only those controls covered by the operating instructions. Improper adjustment of other controls may result in damage, and may require extensive work by a qualified service technician to restore the product to normal operation.
15. Avoid using this fax machine during a lightning storm. There may be a remote risk of electric shock from lightning. If possible, unplug the AC power, telephone, and PC interface cords for the duration of the lightning storm.
16. Never dispose of batteries or battery packs in a fire. There is a serious risk of explosion and/or the release of highly toxic chemicals.
17. **SAVE THESE INSTRUCTIONS.**





# *Getting Started*

# Setting up your machine

---

## Unpacking

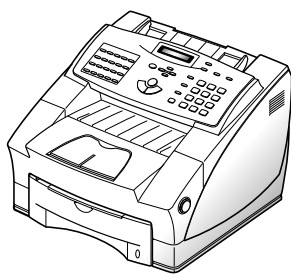

**Machine**

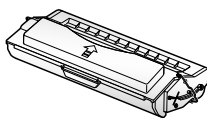

**Toner cartridge**

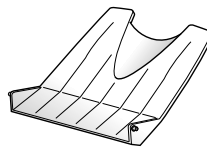

**Printer exit tray**

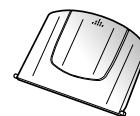

**Document tray**

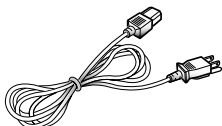

**AC power cord \*1**



**Telephone/modem  
line cord \*1**

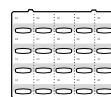

**One-touch  
label**



**Laser facsimile  
user's guide**

*\*1 The shape of AC power and telephone line cord plugs may differ, depends on your country.*

## Control locations and functions

Take a moment to familiarize yourself with the main components and understand their functions.

**Caution** : Use of controls or adjustments other than those specified herein may result in radiation exposure.

### Front view

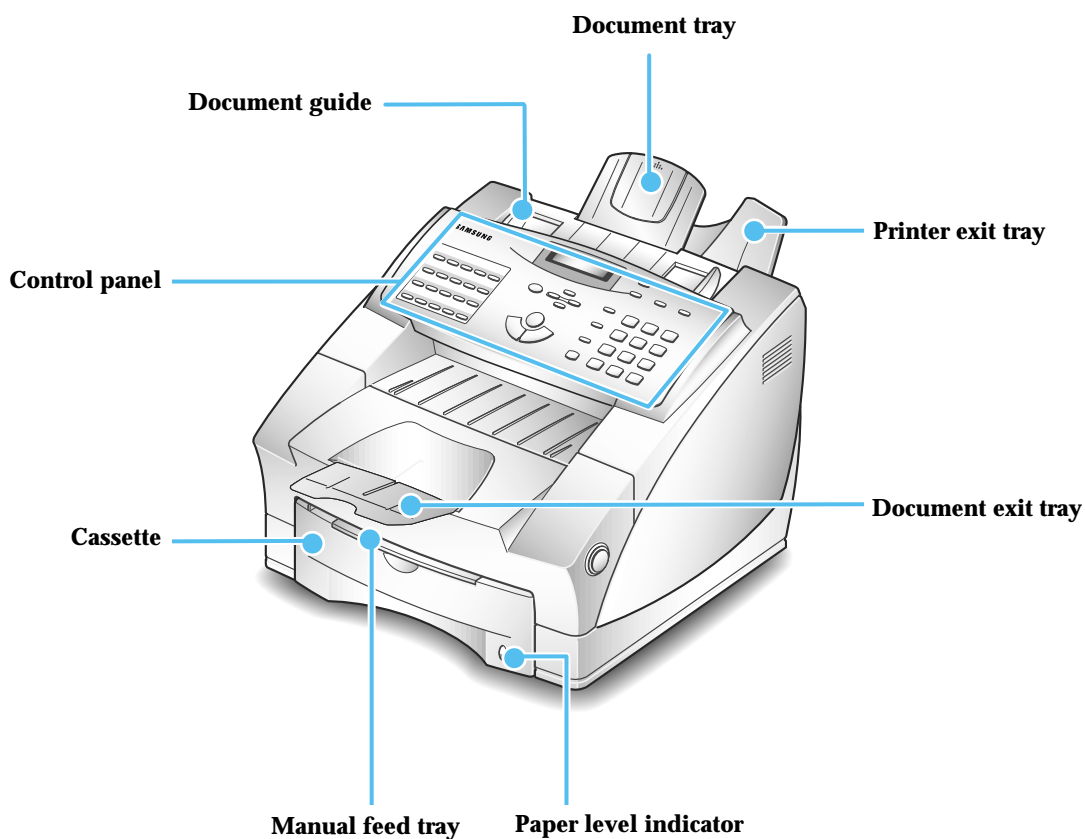

**Note:** Your machine may look slightly different from the illustration.

**Rear view**

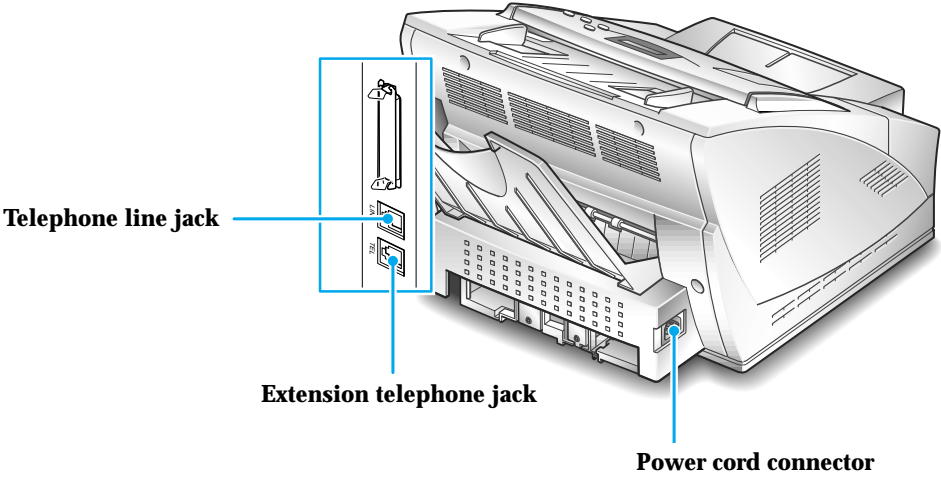

**Inside**

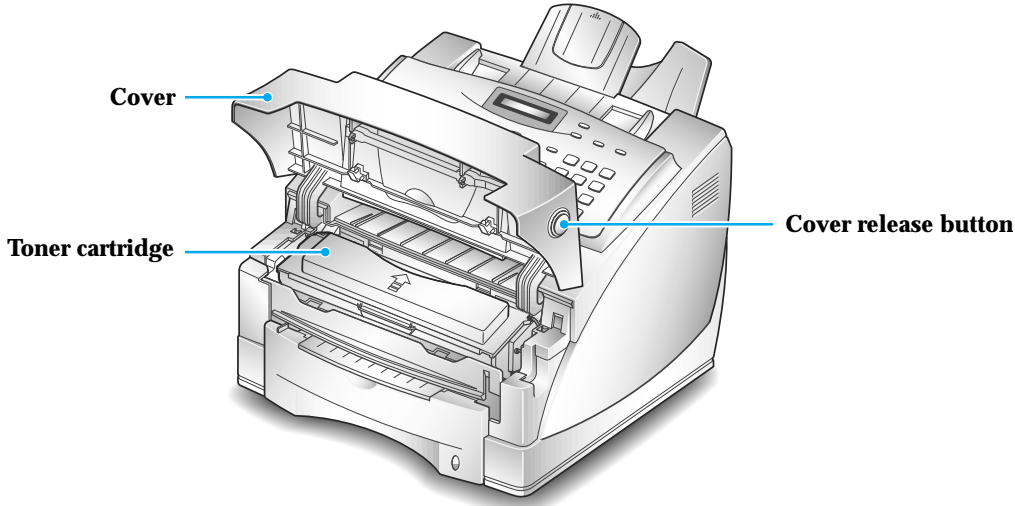

---

## Choosing a location

To help guarantee trouble-free operation of your machine, place it on a flat, stable surface near your workstation. Leave enough space to allow for easy paper loading, paper out and opening the front cover.

Do not place your machine:

- In direct sunlight.
- Near heat sources or air conditioners.
- In dusty or dirty environments.

---

## Setting up your machine

### Installing the toner cartridge

1. Open the cover by pressing the cover release button.

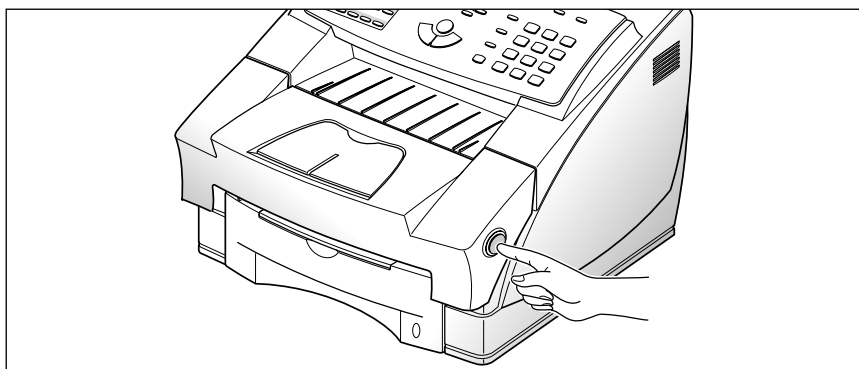

2. Raise the cover.

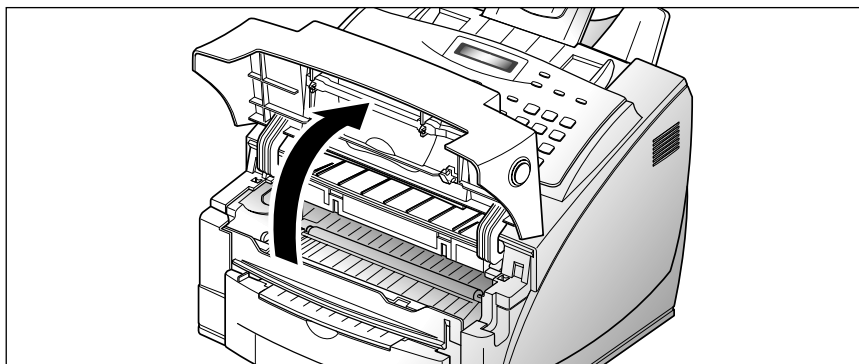

3. Unpack the toner cartridge. Grip the cartridge firmly and pull the sealing tape slowly from the cartridge. You may feel some initial resistance.

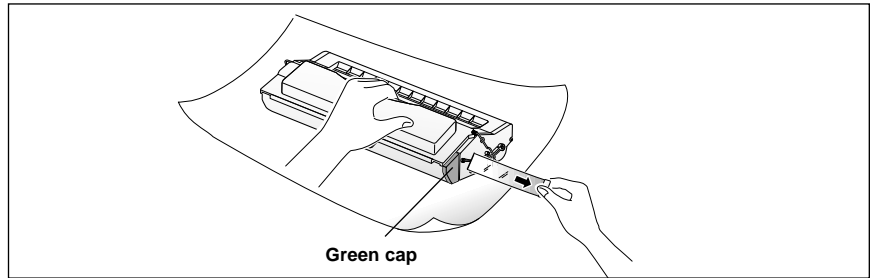

As the tape will have a small amount of toner on both sides, take care not to get toner on your clothes.

**Remove the green cap from the right side of the cartridge.**

4. Gently shake the cartridge from side to side 5 or 6 times to distribute the toner evenly inside the cartridge.

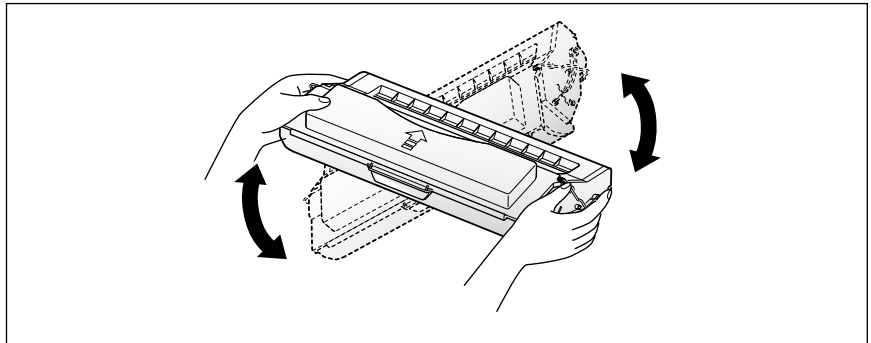

5. Find the cartridge slots inside the machine, one on each side.

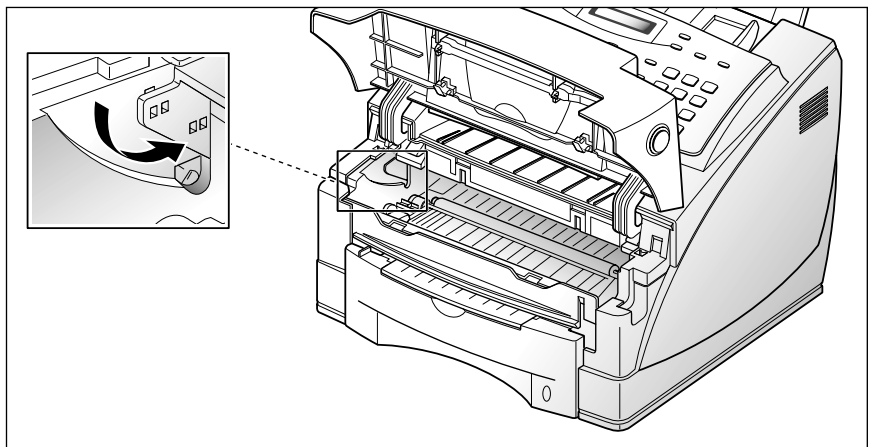

6. Grasp the handle and slide the cartridge down between the cartridge slots, until it drops into place.

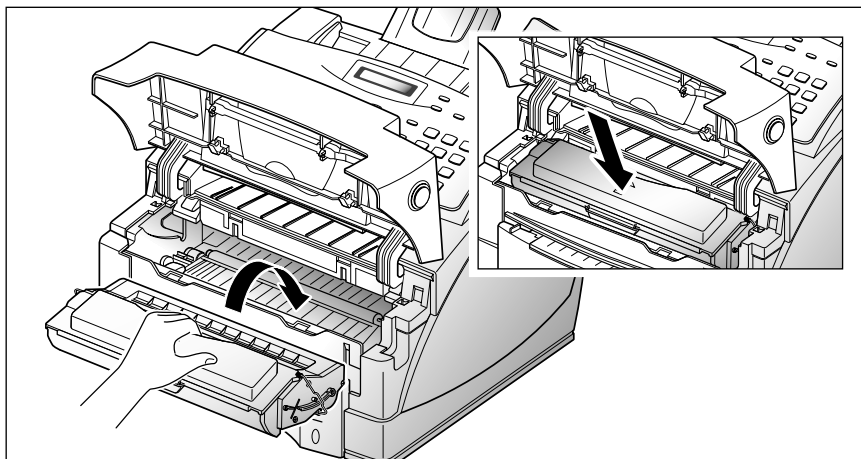

7. Close the cover. Make sure that the cover is securely closed.

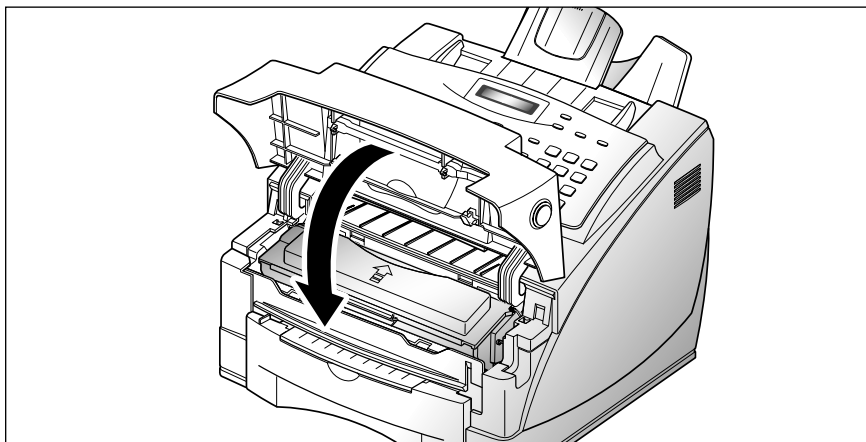

**Notes:**

- *Do not expose the cartridge to direct sunlight or strong room light.*
- *To avoid damaging the photo-sensitive drum, never open the drum shutter.*
- *To avoid damaging the cartridge, complete cartridge installation as quickly as possible.*
- *If toner gets on your clothing, wipe it off with a dry cloth and wash clothing in cold water.*
- *When printing text at 5% coverage, you can expect a toner cartridge life of approximately 6,000 sheets.*

## Loading paper into the cassette

You can load approximately 250 sheets of paper in the paper cassette.

The window on the front of the paper cassette shows the amount of paper currently left in the cassette. When the cassette becomes empty, the window turns into red.

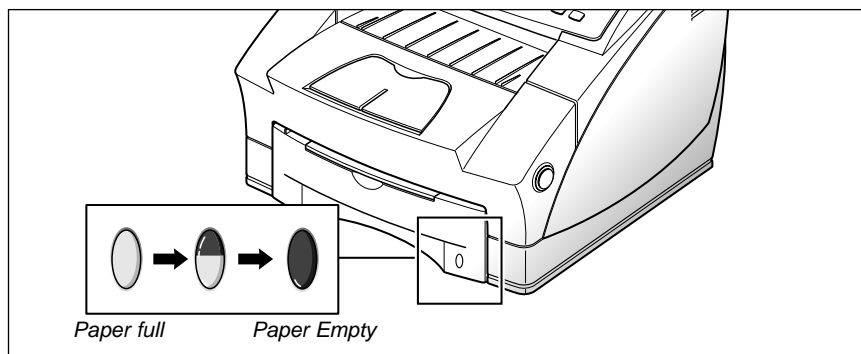

### To load a stack of paper

1. Remove the paper cassette by pulling it toward you.

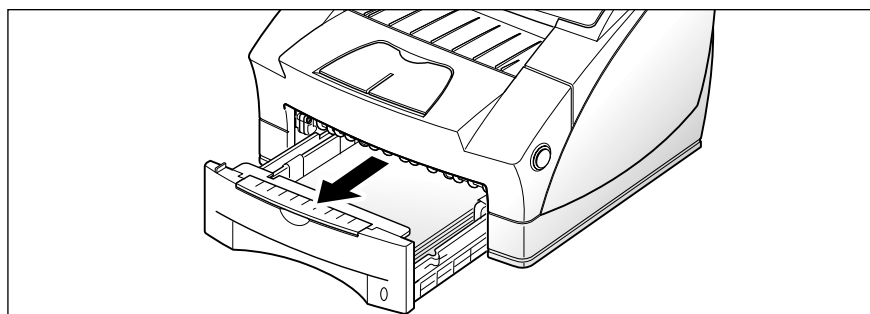

2. Fan the paper and load the paper in the cassette under the guides with the print side face down. The print side is usually indicated on the paper package.

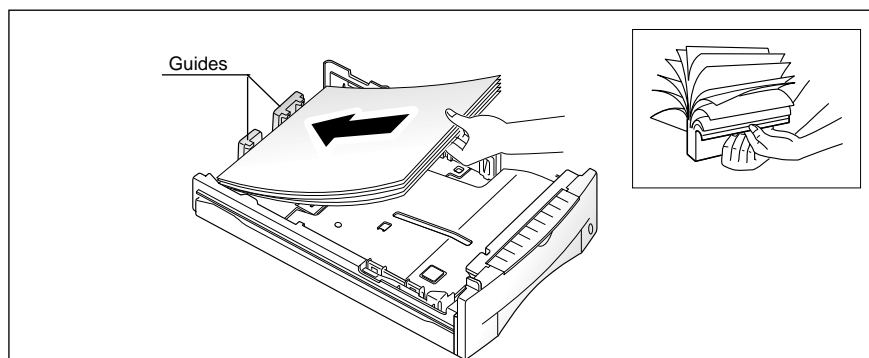



If you are using a preprinted stock, such as letterhead, place the printed side face down with the top edge of the page toward the front of the cassette.

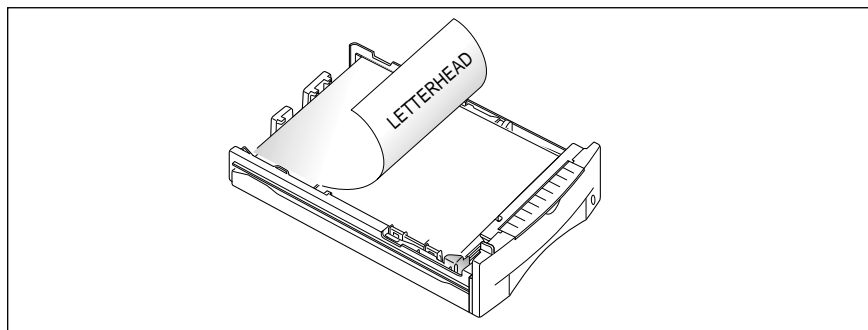

3. Make sure that the stack goes under the metal retaining clip **(A)**. Paper overloading may cause paper jams.

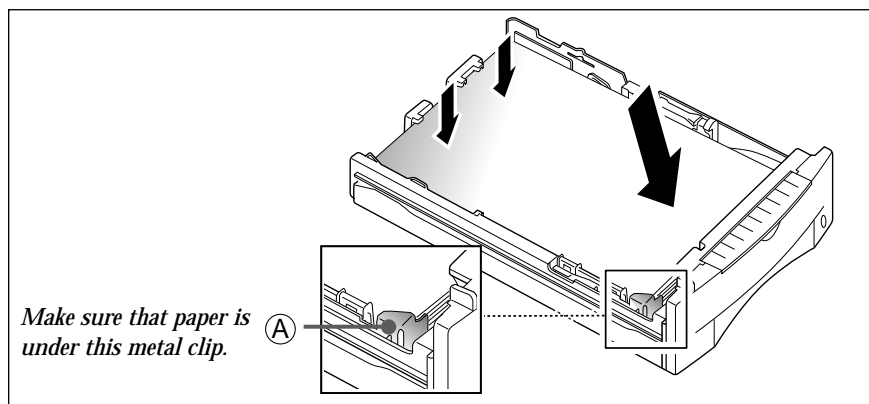

4. Make sure that the stack of paper does not exceed the line indicated by **▼** mark on the left inside wall of the cassette.

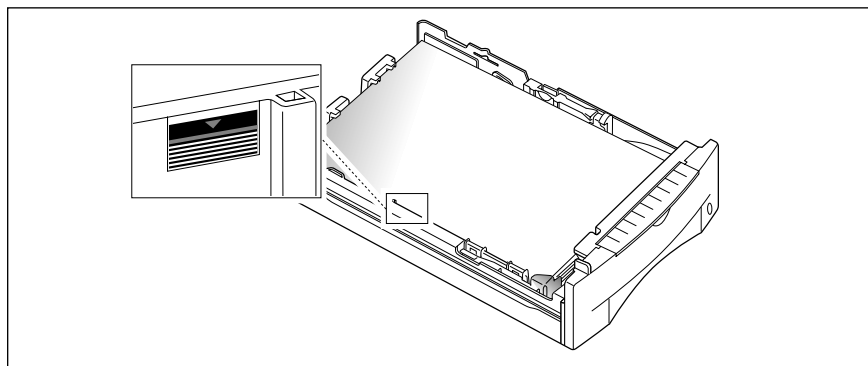

5. Pinch the side guide as shown below to adjust it to proper paper width.

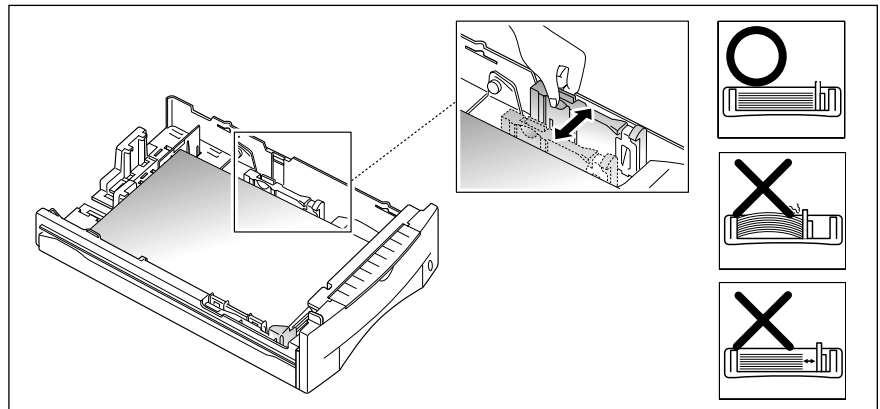

The paper cassette is preset to load letter size paper. If you want to load A4 or legal size paper, adjust the cassette for the paper you want to load. For details on how to adjust the paper cassette, see 'How to adjust paper guides' on page 1.11.

6. Insert the cassette back into the printer.

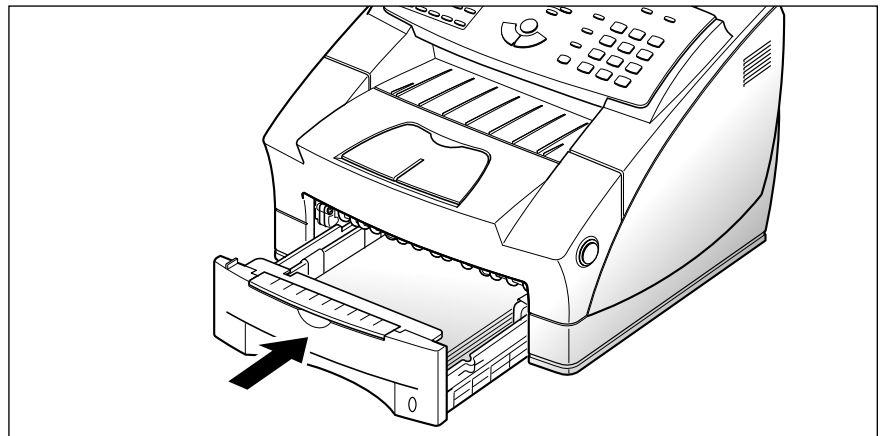

## How to adjust paper guides

### Length guides

There are two main guides and one auxiliary guide as shown below to adjust for the paper length. One of main guide is for legal, A4, or folio size, and the other is for letter (LTR), executive (EXEC), or B5 size paper. When you load letter size paper, it is recommended that you use the auxiliary guide on the upper right corner of the cassette with the appropriate main guide.

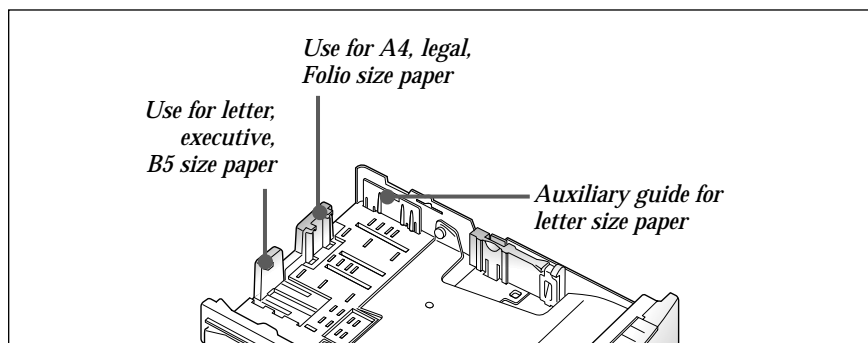

To adjust for legal, or folio size paper, pinch the right guide, then slide the guide until it lightly rests against the edge of the paper stack.

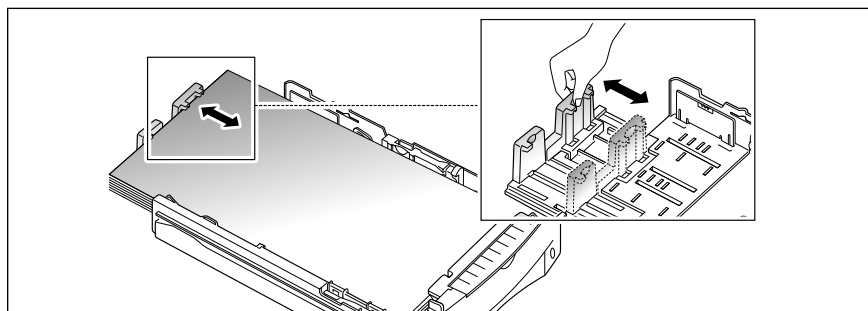

To adjust for letter (LTR), executive (EXEC), JIS B5, or ISO B5 size paper, squeeze the left guide and slide it until it lightly rests against the paper stack.

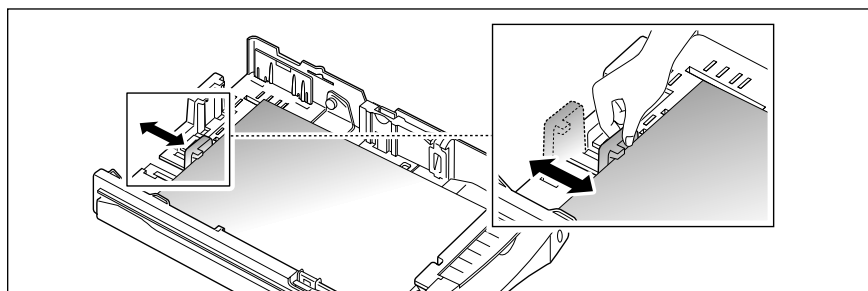

When you load letter, executive, or B5 size paper, it is recommended that you use the auxiliary guide with the main guide before loading paper. To adjust the auxiliary guide, remove the guide **1**, then insert it to the appropriate position **2**.

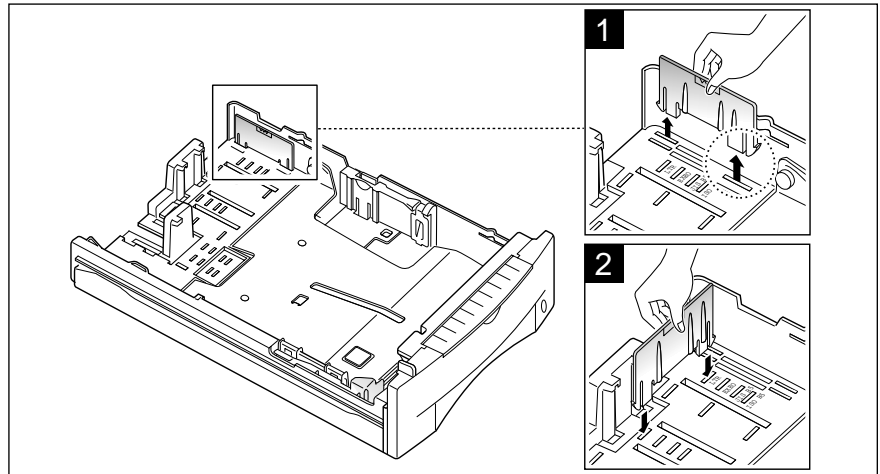

### Width guide

Squeeze the guide as shown and slide the guide to the left until it lightly rests against the edge of the paper stack.

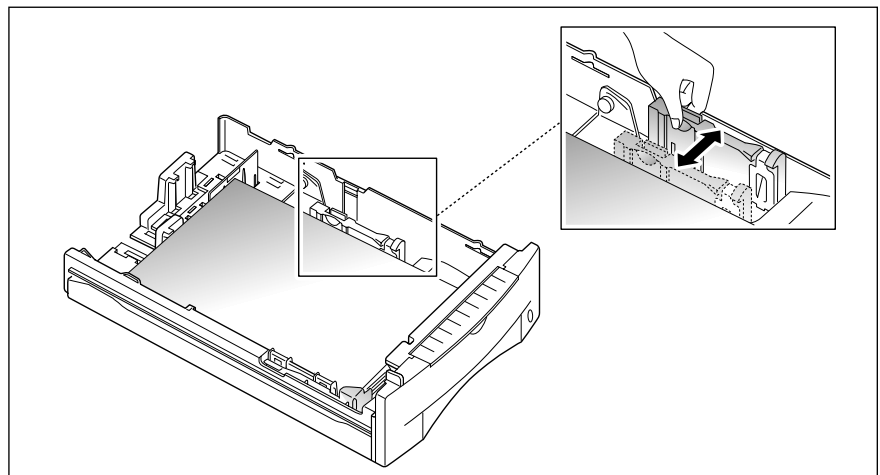

**Note:** Do not push the width guide far enough to cause the paper to bend. If you do not adjust the width guide, it may cause paper jams.

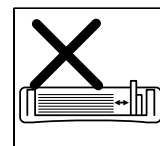
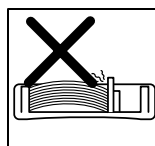
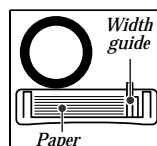

## Manually feeding paper

When you copy on heavier weight papers, transparencies, you must manually feed them one sheet at a time through the manual feed slot. The manual feed slot is located on the top of the paper cassette.

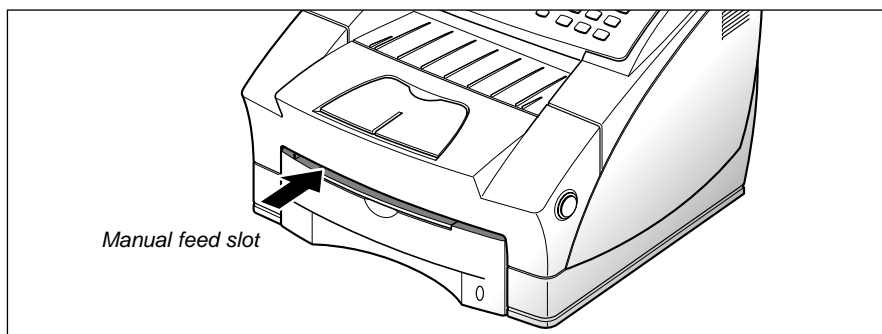

1. Pull out the paper cassette, raise and then lower the manual feed tray toward you.

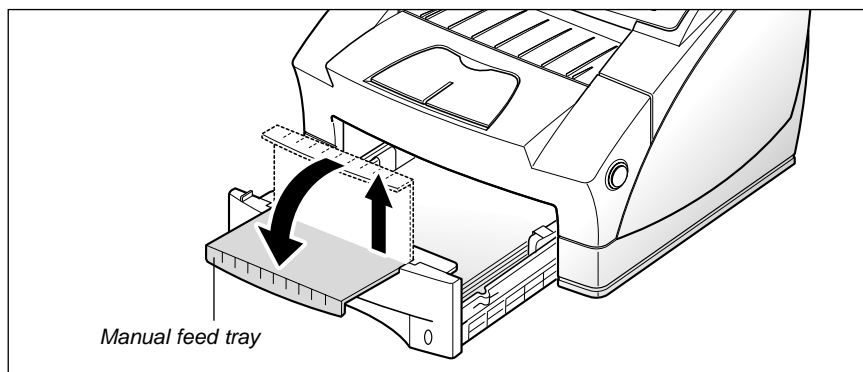

2. Load the desired print material in the manual feed slot with the left edge to the far left of the slot. You must feed one sheet at a time.

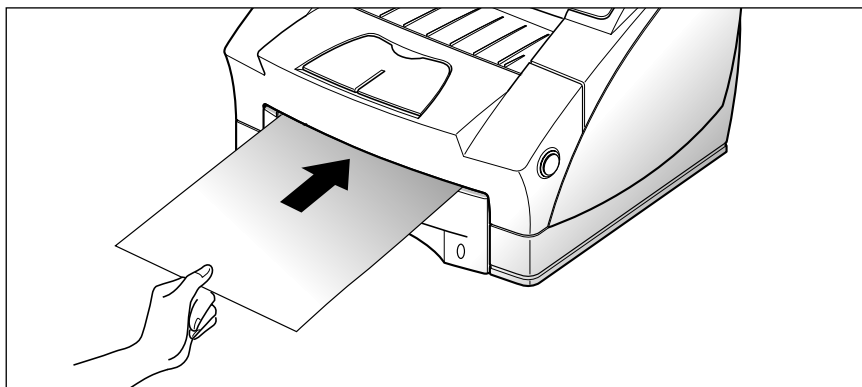

## Guidelines for the paper

When selecting or loading paper, or other special media, keep these guidelines in mind:

- Attempting to print on damp, curled, wrinkled, or torn paper can cause paper jams and poor print quality.
- Use cut-sheet paper only. You cannot use multiparty paper.
- Use only high quality, copier grade paper. Avoid paper with embossed lettering, perforations, or textures that are too smooth or too rough.
- Colored paper should be of the same high quality as white photocopy paper. The pigments must withstand the printer's fusing temperature of 392 °F (200 °C) for 0.1 second without deterioration. Do not use paper with a colored coating that was added after the paper was produced.
- Pre-printed forms must be printed with non-flammable, heat-resistant inks that do not melt, vaporize, or release hazardous emissions when subject to the printer's approximately 392 °F (200 °C) fusing temperature for 0.1 second.
- Store paper in its ream wrapper until ready to use. Place cartons on pallets or shelves, not on the floor. Do not place heavy objects on top of the paper, whether it is packaged or unpackaged. Keep paper away from moisture, or other conditions that can cause it to wrinkle or curl.
- During storage, moisture-proof wrapping (any plastic container or bag) should be used to prevent dust and moisture from contaminating your paper.
- Always use paper and other media that conform with those listed under 'Specifications' on page 4.7.

## Telephone line

Plug one end of the telephone line cord into the **LINE** jack and the other end into a standard phone wall jack.

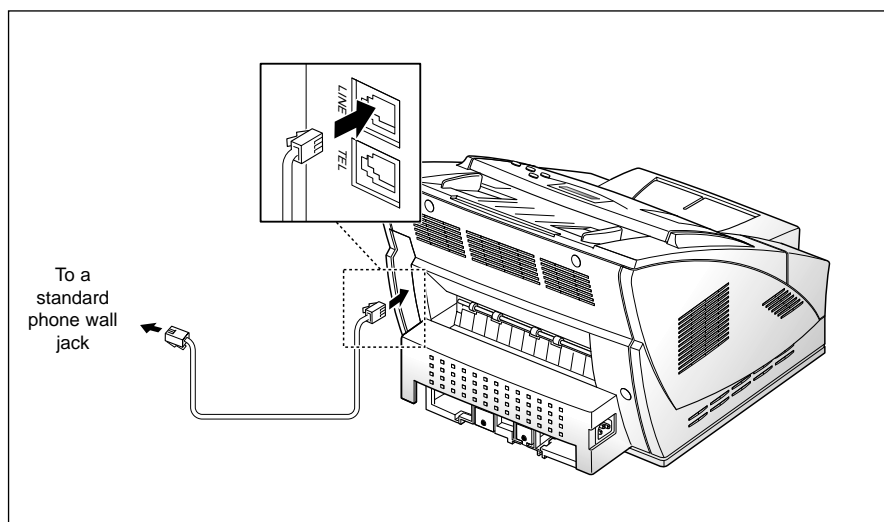

## Extension phone

If you want to use a regular phone or answering machine with your machine, connect the phone into the **TEL** jack.

Plug the cord of your regular phone or answering machine into the socket marked **TEL** on the back of the machine.

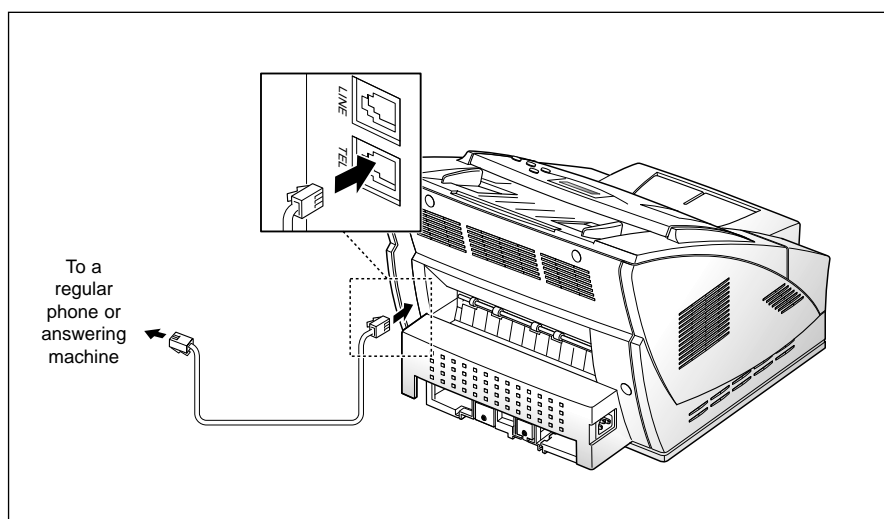

## AC power cord

Plug one end of the cord into the back of the machine and the other end into a standard AC power outlet (use 120 Volt only).

The machine turns on. If there is no cartridge installed, or no paper, the display shows 'DOOR OPEN OR NO TONER CARTRIDGE' or '[NO PAPER]'.

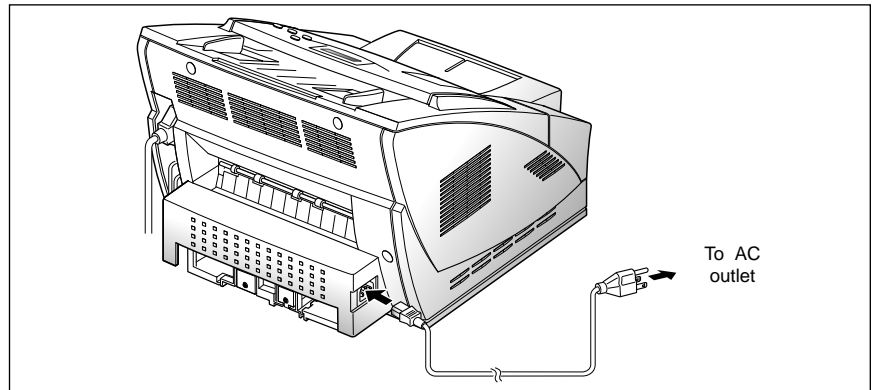

If you want to turn it off, unplug the power cord.

## Document tray

Holding the document tray with both hands, push the tab on one end of the tray into the hole as show. Gently squeeze the other side of the tray toward the middle so the tab on the other end can be easily placed into the other hole. Fold out the extender, if necessary.

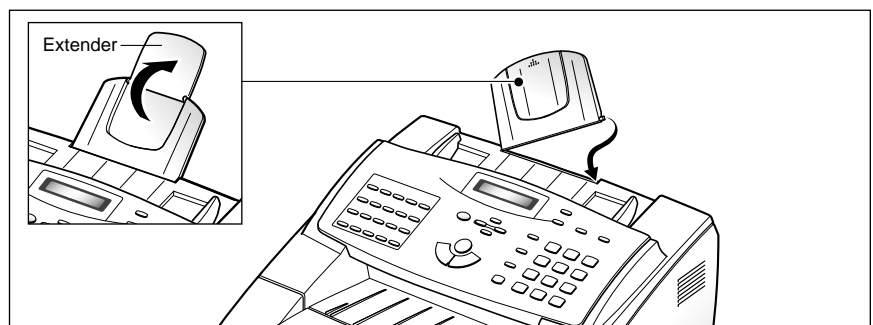



## Document exit tray

Fold out the document exit tray, if necessary.

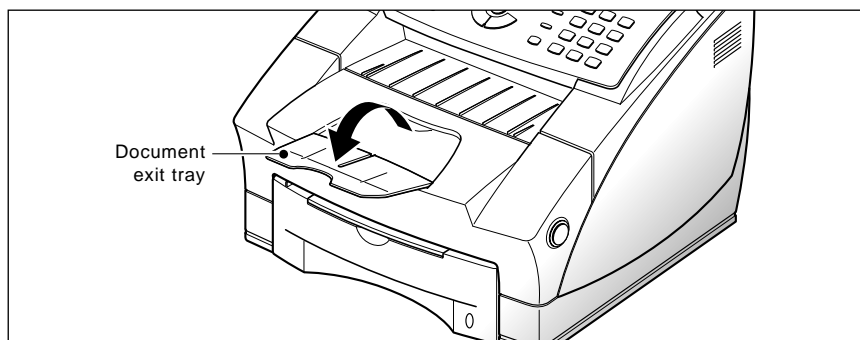

## Printer exit tray

Holding the rounded end, insert the two tabs into the corresponding slots on the back of the machine.

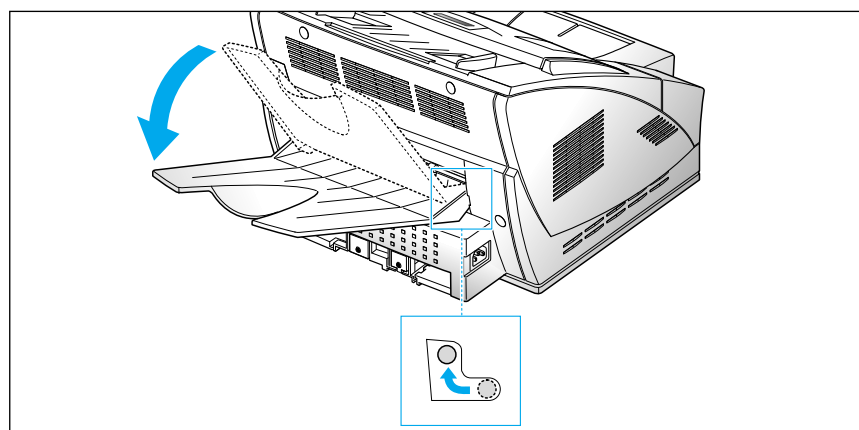
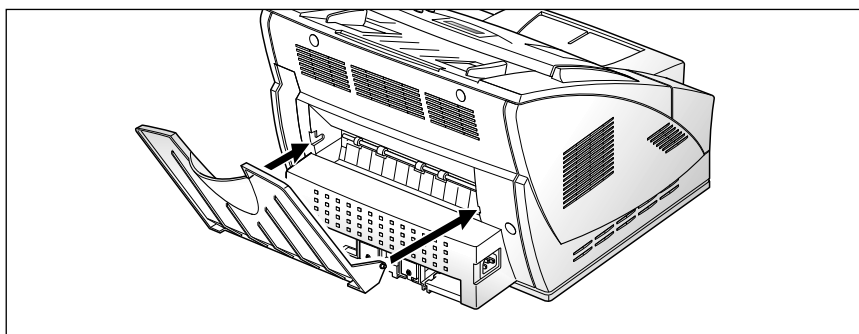

Place the printer exit tray up or down depending on the type of the paper. For transparencies such as OHP film, lay it down as show at up. When the printing is finished, replace the tray.

---

## System setup

### Ringer volume

You can adjust the volume of the ringer to the desired loudness.

1. Press **Menu**, then press **System Setup** on the one-touch keypad.  
The display shows 'RINGER VOLUME ?'.
2. Press **Start/Enter**, then use ▲ or ▼ to choose the desired loudness of the ringer.

The selected ringer sounds and the display shows the loudness level with > symbol.

No > symbol turns the ringer off. The machine will work normally even if the ringer is turned off.

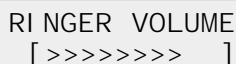

RINGER VOLUME  
[ >>>>>>>> ]

3. Press **Start/Enter** when the desired volume level is selected. The display shows the next setup menu 'DEFAULT SETTINGS ?' For details on menu, see below.
4. To return to standby mode, press **Stop**.

### Home resolution and home contrast

The print resolution and contrast can be set to their most frequently used modes. Whenever a document is sent or copied, the home contrast and resolution mode will be activated unless otherwise changed by using **Resolution** or **Contrast** button on the control panel. See page 2.8 for details.

1. Press **Menu**, then press **System Setup** on the one-touch keypad.  
The display shows 'RINGER VOLUME ?'.
2. Press ▲ or ▼ until you find 'DEFAULT SETTINGS ?'.

3. Press **Start/Enter**. The display asks you to choose the home resolution mode.

```
HOME RESOLUTI ON  
[ STANDARD ]
```

4. Press ◀ or ▶ repeatedly until you find the desired mode:
  - STANDARD–use with most documents.
  - FINE–use for documents with fine detail, such as small print.
  - SUPER FINE–use for documents that have extremely fine detail.
5. Press **Start/Enter** when you find the mode. The display asks you to choose the home contrast mode.

```
HOME CONTRAST  
[ NORMAL ]
```

6. Press ◀ or ▶ repeatedly until you find the desired mode:
  - NORMAL–use with documents of average or normal contrast.
  - DARKEN–use with documents with low contrast or light images.
  - LIGHTEN–use with documents with high contrast or dark images.
  - PHOTO–for obtaining maximum image quality with documents that contain pictures or photographs with shades of gray.
7. Press **Start/Enter** when you find the mode. The display shows the next setup menu 'SOUND CONTROL ?'. For details on 'Sound control' menu, see the next page.
8. To return to standby mode, press **Stop**.

## Sound control

You can choose an alarm tone to sound when an error occurs (ALARM SOUND) or any key is pressed (KEY SOUND).

1. Press **Menu**, then press **System Setup** on the one-touch keypad. The display shows 'RINGER VOLUME ?'.
2. Press **▲** or **▼** until you find 'SOUND CONTROL ?'.
3. Press **Start/Enter**. The display prompts you to turn ON or OFF the alarm sound.
4. Press **1** to turn the sound ON, or **2** to turn it OFF. You can also use **◀** or **▶** button to choose 'ON' or 'OFF', then press **Start/Enter** to confirm.
5. The display asks you to turn ON or OFF the key sound. Press **1** to turn the sound ON, or **2** to turn it OFF.
6. The display shows the next setup menu. To return to standby mode, press **Stop**.

## Remote diagnosis protection

Remote diagnosis feature allows your machine to be checked by a service company from a remote place through the phone line.

If you do not want to use the remote diagnosis feature and want to protect your machine from being opened by an unauthorized person, you can enable this remote diagnosis protection feature.

1. Press **Menu**, then press **System Setup** on the one-touch keypad. The display shows 'RINGER VOLUME ?'.
2. Press **▲** or **▼** until you find 'REMOTE DIAGNOSIS PROTECTION ?', then press **Start/Enter**.
3. The display asks you to turn the feature ON or OFF. Press **1** to turn it ON, or **2** to turn it OFF.
4. The display shows the next setup menu. To return to standby mode, press **Stop**.

## Select language

You can select the LCD display language between english, german, etc.

1. Press **Menu**, then press **System Setup** on the one-touch keypad.  
The display shows 'RINGER VOLUME ?'.
2. Press **▲** or **▼** until you find 'SELECT LANGUAGE ?', then press **Start/Enter**.
3. Press **▲** or **▼** to choose the desired display language, then press **Start/Enter**. You can also press the number of the language in the display.
4. The display shows the next setup menu. To return to standby mode, press **Stop**.

## Econo mode setting

To get the most from your toner supply, set the econo mode to on. If set to on, you can preserve the toner supply. The print quality may be reduced.

1. Press **Menu**, then press **System Setup** on the one-touch keypad.  
The display shows 'RINGER VOLUME ?'.
2. Press **▲** or **▼** until you find 'ECONO MODE SETTING ?', then press **Start/Enter**.
3. The display asks you to set the mode to ON or OFF. Press **1** to set ON, or **2** to set OFF.
4. The display shows the next setup menu. To return to standby mode, press **Stop**.

---

## Adjusting speaker volume

1. Press **OHD<sup>1)</sup>/V.Req.** to adjust the speaker volume. If you cannot hear a dial tone, check the phone line connection.
2. Press **▲** or **▼** repeatedly until you find the desired loudness. The display shows the current volume level.
3. After choosing the desired volume level, press **OHD<sup>1)</sup>/V.Req.**.

Note : <sup>1)</sup> **OHD** : On Hook Dial

---

## Setting the date and time

The current date and time are shown in the display window when the machine is on and ready for use (standby mode). The date and time are printed on all faxes you send.

1. Press **Menu**, then press **Date & Time** on the one-touch keypad.  
The display shows the currently set date and time.
2. Using the number keypad, enter the current date in MMDDYYYY format. If you make a mistake, use the **◀** or **▶** buttons to move the cursor to the digit you wish to change.

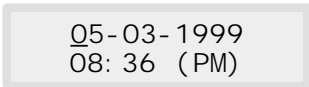

05-03-1999  
08:36 (PM)

After entering the date the flashing cursor will move into the first digit of the time.

3. Using the number keypad, enter the current time. You can choose 12 or 24 hour format. Refer to the previous section, for the details see page 2.46 clock mode.

**Note** : AM or PM is selected by pressing the **▲** or **▼** buttons.

4. Press **Start/Enter** when the date and time in the display is correct.  
The display shows the date and time you have set, then returns to standby mode.

**Note** : If you enter an invalid number, the machine beeps and will not proceed to the next step. If this happens, just reenter the correct number.

## Setting the system ID (your number and name)

The system ID will be printed at the top of each page sent from your machine.

1. Press **Menu**, then press **System ID** on the one-touch keypad.  
The display asks you to enter the telephone number.

If there is a number previously registered, the number appears.

2. Enter the telephone number (up to 20 digits) which your machine is connected to. You can include + and - symbol by pressing \* and # respectively.

If you make a mistake, press ◀ or ▶ to move the cursor under the wrong digit, then enter the correct number to change or press **Search/Delete** to delete the number.

3. Press **Start/Enter** when the number in the display is correct. The display asks you to enter your ID name.
4. Enter your ID name (up to 20 characters).

You can enter alphanumeric characters using the number keypad. Include special symbols by pressing 0 repeatedly.

For details on how to use the number keypad to enter alphanumeric characters, see page 2.4.

If you want to enter the same letter or number in succession (e.g. SS, AA, 777), enter one digit, then move the cursor by pressing ▶, and enter the next digit.

If you want to insert a space in the name, you can also use ▶ button to move the cursor to skip the position.

5. Press **Start/Enter** when the name in the display is correct.

**Note:** *If there is a number and name previously registered, this number and name appears in the upper line and 'ED:1 DEL:2 NXT:3' in the bottom line.*

*Press 1 to edit the existing number. Press 2 to delete the number. The machine deletes the number and continues next step. Press 3 to keep the number and continue.*





# *Operation*



## Using the control panel

### LCD display

The display shows the current status of your machine and guides you through various tasks using a menu system for each operation.

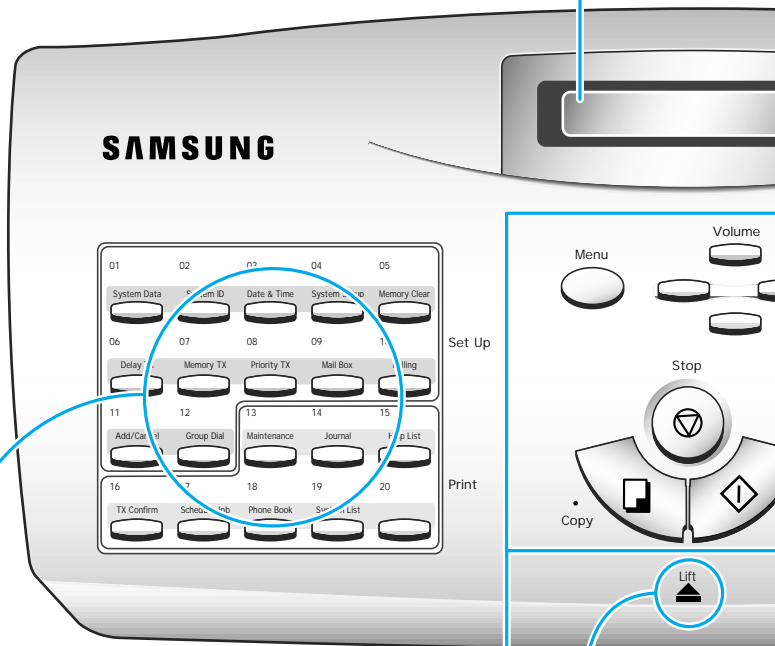

### One-touch dial and special function buttons

Use to call most frequently used numbers with one button. Also, use these buttons with **Menu** button to set up special functions or print lists.

### Menu

Use to choose special functions.

### ▲ and ▼

Use to display the next or last menu item. Also, use to adjust audible volume.

### ◀ and ▶

Use to move cursor left or right through the display.

### Stop

Use to stop an operation at any time.

### Copy

Use to copy a document.

### Start/Enter

Use to start a job. Also use to activate the selection shown in the display.

### Lift

To open the control panel, lift up this point as show in the left figure.

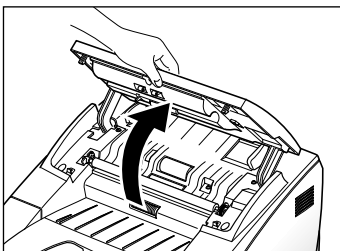

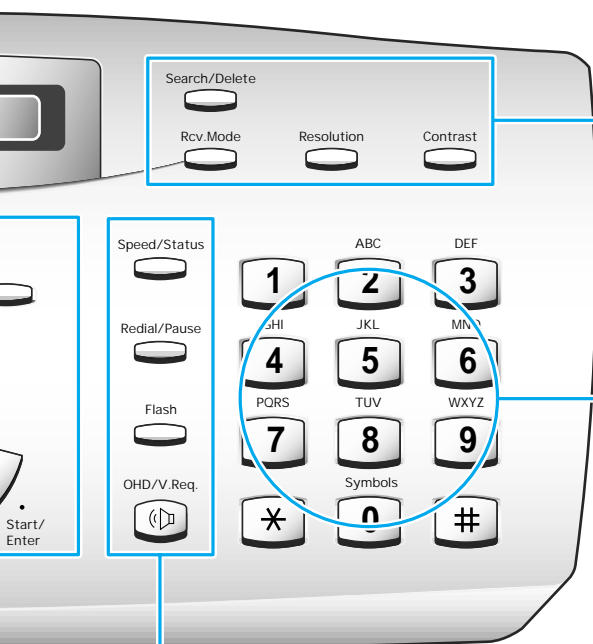
**Search/Delete**

Use to search for numbers in memory.  
Or use to delete digits in the edit mode.

**Rcv.Mode (Receiving mode)**

Use to choose the receive mode you want to use. See page 2.17. The selected mode is displayed.

**Resolution**

Use to choose the resolution of transmitted documents.

**Contrast**

Use to choose the contrast of copied or transmitted documents.

**Number keypad**

Use to dial numbers manually or to enter letters.

**Symbols**

Use to enter special characters (plus sign, etc.)

**Speed/Status**

Use to dial calls and send fax documents by entering a speed dial number.  
Also use to switch the LCD while performing dual jobs.

**Redial/Pause**

Use to redial the last phone number called. You can also use it to add a pause when storing a number in memory.

**Flash**

Use to perform a switch-hook operation such as call waiting.

**OHD (On Hook Dial) / V.Req (Voice Request)**

Use to dial numbers without picking up the handset. Also use it to make a voice call after sending or receiving a fax.

---

## Using the number keypad

As you perform various tasks, you will need to enter names and numbers. For example, when you set up your machine you enter your name (or your company's name) and telephone number. When you use the one-touch dial or speed dial, you also enter the telephone numbers and names.

When the display asks you to enter a name, the LCD display reads:



I D) \_

You can then use the procedures described below to enter up to 20 letters and special characters, numerals, or spaces.

### Entering alphanumeric characters

You can include special characters (plus sign, etc.) in the name by using **0** key. See 'Keypad character assignments' on page 2.5.

1. Locate the button labeled with the letter you want – then press the button repeatedly until the correct letter appears in the display.

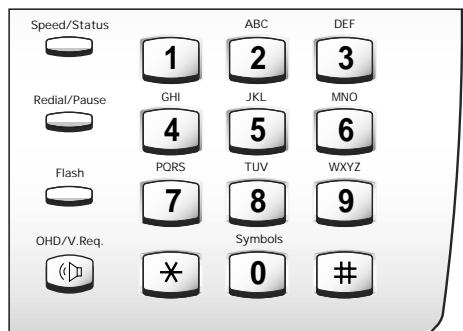

For example, to enter an O, press **6** (labeled MNO). Each time you press **6** the display shows a different letter—first M, then N, and O, and finally 6.

The letter appears in the display.



I D) O

- When the letter you want appears in the display, press the number key labeled with the next letter you want.

If the next letter is found on the same number button, move the cursor by pressing **▶**, then press the desired button.

The blinking cursor moves right and the next letter appears in the display.

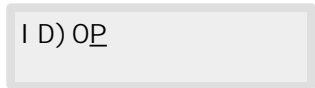

- Select additional letters in the same way. When you're finished entering letters, press **Start/Enter**.

### Keypad character assignments

Key	Assigned numbers, letters, or characters
1	Space → 1
2	A → B → C → 2
3	D → E → F → 3
4	G → H → I → 4
5	J → K → L → 5
6	M → N → O → 6
7	P → Q → R → S → 7
8	T → U → V → 8
9	W → X → Y → Z → 9
0	+ → - → , → . → ' → / → * → # → & → 0

## Entering numbers

You can enter the number of the remote fax machine manually by using the number keypad. The number you pressed appears in the display.

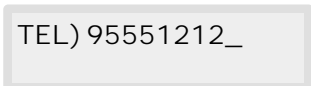

TEL) 95551212\_

When the display asks you to enter a number, you can also use a one-touch dial button (including group dial) and speed dial number.

## Editing numbers or names

If you make a mistake while entering a number or name, move the cursor under the wrong digit by using ◀ or ▶. Then press the correct number to change, or press **Search/Delete** to delete the number.

## Inserting pause

With some private telephone systems, you must dial an access code (9, for example) and listen for a second dial tone before dialing an outside number. In such cases, you must insert a pause in the number. Insert a pause in a number when you are setting up a one-touch or speed dial number, or when you dial a number without lifting the handset.

To insert a pause, press **Redial/Pause** while entering the number.

When you dial a number, the dialing process pauses for about 3~4 seconds at the point where you pressed **Redial/Pause**.

If you require a longer pause time, press **Redial/Pause** twice.

# ***Sending a fax***

---

## **Preparing documents for faxing or copying**

You can use the machine to fax, or copy documents that are printed on standard letter, legal, or A4 size paper. Follow these guidelines to prepare your documents.

- Do not attempt to feed the following types of documents into the machine. Instead, make copies and insert the copies into the document tray.
  - wrinkled or creased paper
  - curled or rolled paper
  - torn paper
  - carbon-paper or carbon-backed paper
  - coated paper
  - onion skin or thin paper
- Remove all staples, paper clips, and the like before feeding the document.
- Make sure any glue, ink, or correction fluid on the paper is completely dry before feeding the document into the machine.
- Do not feed documents with pages that are different sizes or of different thicknesses.

---

## Setting document resolution and contrast

We recommend sending documents printed using a typewriter, felt tip pen, black ink, or laserprinter. The paper should be white or very light, and of normal weight not cardboard. Blue lines on a ruled pad do not fax well.

When you send normal documents, you need not adjust the resolution and the contrast.

If you send documents with unusual contrast characteristics, including photographs, you can adjust the resolution and contrast to send a high-quality transmission of the documents.

### Resolution

Press **Resolution** button to increase sharpness and clarity. By pressing **Resolution** button repeatedly after loading a document, you can choose between **STANDARD**, **FINE** or **SUPER FINE** mode.

**STANDARD** works well for documents with normal sized characters.

**FINE** is good for documents containing small characters or thin lines, or print from a dot-matrix printer.

**SUPER FINE** works well for documents containing extremely fine detail. super fine works only if the remote machine also has the super fine feature.

### Contrast

Press **Contrast** button to compensate for the brightness or darkness of your faxed document. By pressing **Contrast** button repeatedly after loading a document, you can choose between **NORMAL**, **DARKEN**, **LIGHTEN**, or **PHOTO**.

**NORMAL** works well for normal documents.

**DARKEN** works with light print or faint pencil markings.

**LIGHTEN** works with dark print.

**PHOTO** is used when faxing photographs or other documents containing color or shades of gray. Although your machine will not transmit color, it will print and send up to 256 shades of gray.

***Note:** You can set the default resolution and contrast. The default mode will be effective when a document is sent or copied unless you change the setting for individual operation. Once the current operation is completed, the setting will revert to their preset defaults for the next operation. For details on how to set the default resolution and contrast, see page 1.18.*

## Loading document

1. Turn the page face down.
2. Adjust the document guides to match the width of the document.
3. Slide the sheet down into the document tray until it's gripped by the machine.

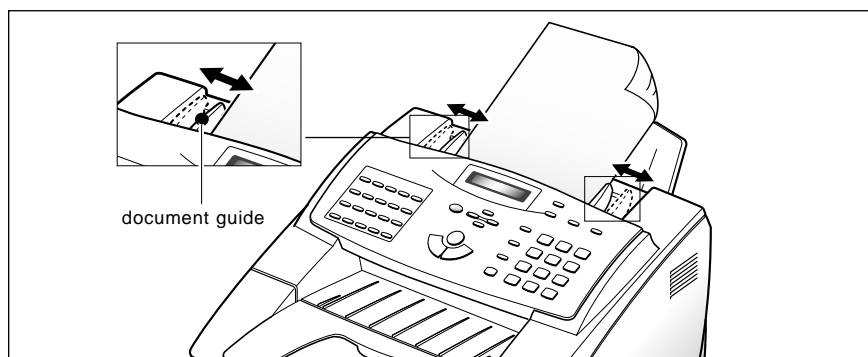

The automatic document feeder sizes and pulls in the page. The display shows 'DOCUMENT READY' and the remaining memory capacity alternatively.

You can insert up to 50 sheets (20 lb Paper) at a time. If you insert more than one sheet, make sure the bottom sheet enters first. Stagger the leading edge of the sheets slightly, and insert the sheets with a slight push to ensure smooth feeding.

To add pages while the fax is being sent, insert them into the loading slot on top of the already loaded sheets.

4. If necessary, use the **Resolution** button to change the resolution and the **Contrast** button to change the contrast (see page 2.8).



---

## Sending a fax automatically

1. After loading a document, enter the number of the remote fax machine using the number keypad.

You can store one-touch or speed dial numbers so that you can dial your most frequently used numbers with one touch of a button or speed dial number. For information on storing and using numbers in memory, see page 2.31.

If you make a mistake while entering a number, move the cursor under the wrong digit by using ◀ or ▶, and correct the number or press **Search/Delete** to delete the number.

2. Press **Start/Enter** to dial the number.

The machine will scan the document and dial the number automatically. When the remote fax machine answers the phone, the document will be transmitted automatically.

### Canceling transmission

Press **Stop** any time during the transmission. The machine continues to send the fax and the display shows a message warning you that the machine is in use. Press **Stop** again.

### Confirming transmission

When the last page of your document has been sent successfully, the machine beeps and returns to standby mode.

If something went wrong during your fax transmission, an error message appears in the display. For a listing of error messages and their meanings, see page 3.6.

If you receive an error message, press **Stop** to clear the message and try to send the document again.

You can set your machine to print a confirmation report automatically each time a fax is successfully sent. For more information, see 'MESSAGE CONF.' on page 2.42.

## Automatic redial

When you send a fax, if the number you have dialed is busy or there is no answer, the machine hangs up, waits for the specified retry term and redials the number. If after the specified number of retry attempts (retry count), the machine fails to connect, the machine returns to Standby mode.

While the machine is redialing, the display shows 'RETRY REDIAL ?'. If you want to redial the number immediately, press **Start/Enter**. To stop redialing, press **Stop**.

You can select the number of retries and the retry term between each redial attempt.

---

## Voice request

If you're sending or receiving a document and need to speak to the other person at the same phone call, use voice request to alert the person at the remote site. You can also respond to a voice request made by the person at the remote end.

***Note:** As the machine is not equipped with handset, separate extension phone should be connected to TEL jack before using the voice request function.*

### Sending a voice request

1. Press **OHD/V.Reg.** while a document is being sent or received. Voice request signal is stored and then sent to the remote fax machine after the document has been sent or received.
2. When the phone rings, pick up the handset and answer it.

You can cancel a voice request by pressing **OHD/V.Reg.** again while you are sending or receiving a document.

### Answering a voice request

When the phone rings after sending or receiving a fax, pick up the handset then press **Stop**.

If you don't answer the voice request, the machine prints out the number that made the voice request, and the time and date the request was made.

---

## Delayed transmission

You can configure your machine to send a fax at a specified time. Up to 50 delayed transmission operations can be reserved in your machine.

1. Place the document face down in the automatic document feeder. If desired, adjust the resolution and contrast. For details, see page 2.8.
2. Press **Menu**, then press **Delay TX** on the one-touch keypad.
3. Enter the telephone number of the remote machine. There are several methods available to do this:
  - Direct entry of the telephone number using the numeric keypad.
  - One-touch keypad dialing of stored telephone numbers (see one-touch dialing on page 2.31)
  - Group and speed number dialing using the numeric keypad (see speed dialing on page 2.33 and group dialing on page 2.34)

***Note:** You can use only one group number at this transmission job in step 3.*

4. Press **Start/Enter**.  
The display prompts you to enter another fax number.

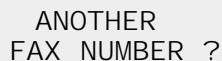

ANOTHER  
FAX NUMBER ?

5. If you have entered the last fax number setting, press **Stop**.

Or

If you want to send the document to more than one location, press **Start/Enter** and enter another fax number using the numeric keypad, one-touch keypad, or speed dial number.

The number appears in the display.

Repeat step 5 until you have entered the last fax number setting and pressed **Stop**.

6. The display prompts you to enter an ID for the transmission. If you want to assign a name to the transmission, enter it using the number keypad. If not, proceed to step 7.

For details on how to enter letters using the number keypad, see entering alphanumeric characters on page 2.4.

7. Press **Start/Enter**. The display shows the current time on the upper line and prompts you to enter the time the fax will be sent.

```
CURRENT 12: 30AM
START   12: 30AM
```

8. Using the number keypad, enter the time the fax will be sent. Use the ▲ or ▼ button to switch between AM and PM. If you set a time earlier than the current time, the document will be sent at that time on the following day.
9. After entering the time, press **Start/Enter**.
10. The machine scans the document into memory, returns to standby mode and displays a reminder that a delayed transmission is set.

**Note:** *If you want to cancel the delayed transmission, see 'Canceling a standby operation' on page 2.16.*

---

## Memory transmission (Broadcasting)

With memory transmission, documents are stored in memory and automatically sent to one or more remote stations. Use this feature to send your documents to multiple locations.

You can store a maximum of 25 fax numbers for a memory transmission. If you need to send your fax to more than 25 locations, you can increase the number of fax locations dialed by including a group dial number as one of the 25 numbers.

After being sent, the documents are automatically erased from memory.

1. Adjust the document guides to match the width of the document.
2. Slide the document *face down* into the automatic document feeder until it is grasped and pulled into the machine.  
If necessary, adjust resolution and contrast. For details, see page 2.8.
3. Press **Menu**, then press **Memory TX** on the one-touch keypad.
4. Enter the telephone number of the remote machine. There are several methods available to do this:
  - Direct entry of the telephone number using the numeric keypad.
  - One-touch key pad dialing of stored telephone numbers (see one-touch dialing on page 2.31).
  - Speed Number dialing using the numeric keypad (see speed dialing on page 2.33).

*Note : Only a single group dial number may be used per memory transmission operation.*

5. Press **Start/Enter**.  
The display prompts you to enter another fax number.

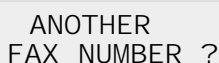

ANOTHER  
FAX NUMBER ?

6. If you have entered the last fax number setting, press **Stop**.  
Or  
If you want to send the document to more than a single location, press **Start/Enter** and enter another fax number using the numeric keypad, one-touch keypad, or speed dial number.

The number appears in the display.

Repeat Step 6 until you have entered the last fax number setting and pressed **Stop**.

7. The document will be scanned into memory. The display shows the remaining memory capacity and the number of pages. The machine dials the first telephone number and begins sending the document.

## Priority transmission

When priority transmission is enabled, a high priority document can be transmitted ahead of previously scheduled operations.

In this operation, the document is scanned into memory. It is immediately transmitted at the conclusion of any operation already in progress.

A priority transmission interrupts a broadcast operation between stations (for example, when transmission to station A ends but before transmission to station B begins), or between redial attempts.

1. Place the document face down in the automatic document feeder. If necessary, adjust the resolution and contrast. For details, see page 2.8.
2. Press **Menu**, then press **Priority TX** on the one-touch keypad.
3. Enter the telephone number of the remote machine. There are several methods available to do this:
  - Direct entry of the telephone number using the numeric keypad.
  - One-touch keypad dialing of stored telephone numbers (see one-touch dialing on page 2.31).
  - Speed Number dialing using the numeric keypad (see speed dialing on page 2.33).

***Note** : Group number dialing functions are not available in a priority transmission.*

4. The display prompts you to enter a name for the transmission.  
To assign a name to the transmission, enter it using the number keypad and press **Start/Enter**.

Or

If you do not want to assign the transmission a name, press **Start/Enter** to skip over this step.

For details on how to enter letters using the number keypad, see entering alphanumeric characters on page 2.4.

5. The document is scanned into memory. The display shows the remaining memory capacity and the number of pages. The machine dials the first telephone number and begins sending the document.

---

## Adding documents to a standby operation

You can add documents to the delayed transmission previously reserved in your machine's memory.

1. Load the document face down. If necessary, adjust resolution and contrast. For details, see page 2.8.
2. Press **Menu**, then press **Add/Cancel** on the one-touch keypad. The display asks you to select 'ADD' or 'CANCEL'.



OPERATION  
1. ADD 2. CANCEL

3. Press **Start/Enter** to confirm 'ADD'. The display shows operation currently reserved in memory.

12-hour format



10: OOPM DELAY TX  
SAMSUNG

24-hour format



22: 00 DELAY TX  
SAMSUNG

(e.g. Delay transmission is scheduled to be sent at 10:00 PM.)

4. Press ▼ or ▲ repeatedly until you find operation you want to add documents, then press **Start/Enter**.

The machine automatically stores the documents in memory, and displays the number of total pages and added pages, then returns to standby mode.

---

## Canceling a standby operation

1. Press **Menu**, then press **Add/Cancel** on the one-touch keypad. The display asks you to select 'ADD' or 'CANCEL'.
2. Press **2** to choose 'CANCEL'. The display shows operation currently reserved in memory.
3. Press ▼ or ▲ repeatedly until you find the operation you want to cancel, then press **Start/Enter** when you find the operation.

# Receiving a fax

## Receiving modes

Your multi-function machine has four receiving modes:

- **FAX** The machine answers an incoming call and immediately goes into receiving mode.
- **TEL/FAX** The machine answers the incoming call. If a fax signal is not detected, the machine sounds a ringing tone to indicate a voice phone call. If the external phone is not lifted while the ringing tone is sounding, the machine will switch to automatic fax receiving mode.
- **ANS/FAX** To use the ANS/FAX mode, you have to attach an answering machine to the **TEL** socket on your machine. If the fax machine senses a fax tone, it automatically switches to fax reception mode. However, if a fax is not sensed, the machine routes the call to answering machine, and the caller can leave a message.
- **TEL** In TEL mode, automatic fax reception is turned off. You can receive a fax only by manually picking up the external phone to accept the call and pressing **Start/Enter** to receiving the fax.

The current reception mode is displayed in the bottom line of the display window when the machine is in standby mode.

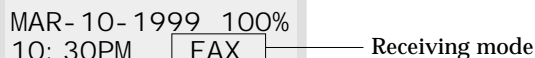

MAR-10-1999 100%  
10: 30PM FAX — Receiving mode

Whenever you press and hold **RCV. Mode** key for about 2 sec. The receiving mode will be changed to next mode (FAX → TEL/FAX → ANS/FAX → TEL → FAX), please check and make sure that correct receiving mode is displayed in the display window.



---

## Receiving automatically in FAX mode

1. Press and hold **Rcv.Mode** for about 2 seconds until the display changes. please repeatit until the display shows 'FAX' in the display window.
2. When a fax call comes in, the machine answers on the preset ring and receives it automatically.

*Note : To change the number of rings before the machine answers an incoming call, see page 2.44.*

To adjust ringer volume, press **Menu, System Setup** on the one-touch keypad, **Start/Enter** to access the ringer volume mode, then use **▲** or **▼** to set the desired loudness.

---

## Receiving automatically in TEL/FAX mode

To use this mode, you must attach a regular phone to the TEL jack on the back of the machine, you can select TEL/FAX mode to receive fax transmissions and answer voice calls.

1. Press and hold **Rcv.Mode** for about 2 seconds until the display changes. please repeatit until the display shows 'TEL/FAX' in the display window.
2. When a call comes in, the machine answers on the default ring. If a fax tone is sensed, the machine receives the automatically.

*Note : To change the number of rings before the machine answers an incoming call, see page 2.44.*

3. If a fax signal is not sensed when the machine answers the call, you will hear a preset ringing tone indicating a voice phone call.
4. Lift the handset to answer the call. If the voice call is not answered within a specified time, the machine will switch to automatic fax receiving mode.

---

## Receiving automatically in ANS/FAX mode

To use this mode, you must attach an answering machine to the **TEL** jack on the back of your machine.

1. Press and hold **Rcv.Mode** for about 2 seconds until the display changes. please repeat it until the display shows 'ANS/FAX' in the display window.
2. Any incoming voice calls will be answered by the answering machine. The caller can then leave a message on the answering machine.
3. If a fax tone is detected on the line, the fax receive mode is automatically activated.

### **Notes:**

- *If you have set your machine to ANS/FAX mode and your answering machine is switched off, or no answering machine is connected to the machine, the machine will automatically go into fax receive mode after several rings.*
- *If your answering machine has a 'user-selectable ring counter', set the machine to answer incoming calls within 4 ring.*
- *If you are in TEL mode (manual reception) when the answering machine is connected to your machine, you must switch off the answering machine, or the outgoing message from the answering machine will interrupt your phone conversation.*

---

## Receiving manually in TEL mode

To use this mode, you must attach a regular phone to the **TEL** jack on the back of the machine, you can answer voice phone calls and receive faxes manually.

1. Press and hold **Rcv.Mode** for about 2 seconds until the display changes. please repeat it until the display shows "TEL" in the display window.
2. Answer an incoming call by picking up the receiver.
3. If you hear a fax tone, or if the person calling asks you to receive a fax, press **Start/Enter** on the machine or a regular phone, press the characters \* 9 \* (star-nine-star) on the regular telephone to initiate reception.

**Note :** *The characters \* 9 \* (star-nine-star) are preset at the factory as the default remote receive start code for machine with a regular phone. The asterisks in the code are fixed characters, but you can be changed. For more information, see on page 2.42.*

4. Replace the handset. The machine begins receiving and returns to standby mode when reception is complete.

## Receiving a fax when the machine is out of paper

Incoming fax transmissions are automatically stored in memory under the following conditions:

- Out of paper
- A paper jam occurs
- A document is copying
- A list is printing

After receiving documents, the machine display 'MEMORY RECEIVED' and the cause. For example, 'NO PAPER'.

When the condition is cleared, for example by loading new paper or clearing a jam, the machine will automatically print the fax stored in memory.

If you clear the problem while the machine is receiving documents into memory, it will print the stored document immediately upon clearing the problem.

## Distinctive ring pattern detection (DRPD) - (option)

"Distinctive ring" is a telephone company service which enables a user to use a single telephone line to answer several different telephone numbers. The particular number someone uses to call you is identified by a distinctive ringing pattern consisting of various combinations of long and short ringing sounds. This feature is often used by answering services who answer telephones for many different clients and need to know which number someone is calling in on to properly answer the phone.

Using the **DRPD (Distinctive Ring Pattern Detection)** feature, this machine can "learn" the ring pattern you designate to be answered by the fax machine. Unless you change it, this ringing pattern will continue to be recognized and answered as a fax call, and all other ringing patterns will be forwarded to the telephone or answering machine plugged into the **TEL** jack. You can easily suspend or change **DRPD (Distinctive Ring Pattern Detection)** at any time. see selectable options on page 2.45.

With the DRPD feature active, 'DRPD' appears in the display and the previously set reception mode is ignored. If you turn DRPD off, the machine returns to any previously set receiving mode.

## Mail box

### Confidential transmission

You can set your machine up to keep documents confidential when communicating with other fax machines that have confidential mail box capability.

#### **Notes:**

- *Make sure that the other party's fax machine sured be are samsung fax machine confidential mail box feature.*
- *Find out the confidential mail box number of the other party.*

1. Load the document face down. If necessary, use resolution, and contrast. For details, see page 2.8.
2. Press **Menu**, then press **Mail box** on the one-touch keypad. The display prompts that you can choose the three mail box options; 1.CONF. TX and 2.SET, 3.PRINT.
3. Press **Start/enter** to confirm '1.CONF. TX' The display asks you to enter a 2-digit mail box number. The mail box number must be preassigned at the remote fax machine.

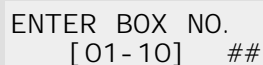

ENTER BOX NO.  
[ 01-10] ##

4. Enter the 2-digit mail box number.
5. Press **Start/Enter** when the number appears correctly in the display. The LCD prompts you to enter the number of the remote fax machine.



TEL)

6. Enter the number of the remote fax machine. You can also use a one-touch button or a speed dial number. The stored number (and name) will be appeared in the LCD.
7. Press **Start/Enter** when the number appears correctly in the display. The LCD prompts you to enter the job name.



I D)

8. If you want to assign a name to the transmission job, enter a name. If not, skip over this step. For details on how to enter letters using the number keypad, see page 2.4.

9. Press **Start/Enter**. The LCD displays the current time on the upper line and asks you to enter the time when the fax is to be sent.

CURRENT 02: 30PM  
START 02: 30PM

10. If you want to send it at a later time, enter the time you want your machine to send the document. If you want to send the document immediately, skip over this step.

Enter the time in same format (12/24 hour) as current time.

If you set a time earlier than the current time, the document will be sent at that time on the following day.

**Note:** AM or PM is selected by pressing for the ▲ or ▼ buttons.

11. Press **Start/Enter** when the time appears correctly in the LCD. The document will be scanned into memory before transmission. The LCD displays the memory capacity and the number of pages.

SCAN TO MEMORY  
95% P. 001

TOTAL PAGES=007

*Note: You can change your machine not to scan the document into memory automatically. Refer to 'Send from memory' under 'User options' on page 2.46. If you turn this feature off, the LCD prompts you at this step to choose either to scan into memory before transmission or not.*

*If you cannot fit all the pages in memory, the machine automatically begins to send the document without waiting all the pages are scanned. But if you registered delayed transmission at step 10, the LCD displays 'MEMORY FULL' and 'CANCEL ?.'*

*To cancel the job, press 1. If you press 2, the pages already scanned will be sent, and you should send the remaining pages in a separate operation.*

The machine returns to standby mode.

18-JUL-1998 95%  
CONF. TX 03: 30PM

*Note: To cancel the confidential transmission setup, see 'Canceling a standby operation' on page 2.16.*

*In case a document loaded in the automatic document feeder, you cannot perform any more tx job such as delay Tx, conf. Tx, and Tx poll unless the document is sent out.*

## Setting up mail box for confidential receiving

Before receiving confidential documents, you have to set up the following:

- Confidential mail boxes. You can have up to 10 confidential mail boxes.
- The password for each mail box
- The names for each mail box. If you do not want to assign the name, you can skip this setup.

The following procedure shows how to register this information.

1. Press **Menu**, then press **Mail box** on the one-touch keypad. The display prompts that you can choose the three mail box options; 1.CONF. TX and 2.SET, 3.PRINT.
2. Press **2** to set up information for confidential receiving. The LCD prompts you to enter a 2-digit number (01 to 10) of the confidential mail box.

ENTER BOX NO.  
[ 01 - 10] ##

3. Enter the 2-digit number (01 to 10) to create confidential mail box.

***Note:** If you enter a box number which has already been registered, the fax machine displays 'CANCEL ?.' Press 1 to cancel the number already registered. If you press 2 you will be asked to enter the new number.*

*If there is any message received in the box you have chosen, 'NUMBER IS REGISTERED!' is displayed and you will be asked to enter the new number.*

4. Press **Start/Enter** when the number appears correctly in the display. The LCD prompts you to enter a 4-digit password. Password '0000' means no code.

ENTER PASSWORD  
[ 0000]

5. Enter a 4-digit security password (0000 to 9999). After you enter the password, it cannot be verified. Write it down and keep it in a secure location for your reference. To change the password, cancel the mail box and setup new mail box with a new password.

This password must be used to print the confidential documents.

6. Press **Start/Enter** when the password number appears correctly. The LCD prompts you to enter a name.
7. If you want to assign a name to the mail box, enter the name. If not, skip over this step. For details on how to enter letters using the number keypad, see page 2.4.
8. Press **Start/Enter**. The LCD returns standby mode.

## Printing received confidential document

When you receive a confidential document, the fax machine displays 'MAIL', total number of mail box which has the confidential document received, and the mail box name in the lower line of the display.

1. Press **Menu**, then press **Mail box** on the one-touch keypad. The display prompts that you can choose the three mail box options; 1.CONF. TX and 2.SET, 3.PRINT.
2. Press **3** to print the received mail. The LCD displays total number of mail box which has the confidential document and mail box name which has the last document.

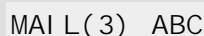

MAIL (3) ABC

3. Press **▼** or **▲** to search for the desired mail box. The mail box names will be displayed in order of mail box number each time you press **▼** or **▲**.
4. Press **Start/Enter** when the desired mail box name is displayed. The LCD briefly displays the selected mail box name and number.

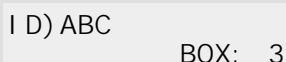

ID) ABC  
BOX: 3

Then, the LCD prompts you to enter a 4-digit password.

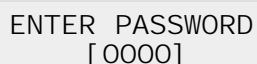

ENTER PASSWORD  
[ 0000]

5. Enter the 4-digit password for that mail box. If you enter a wrong password, the machine sounds a warning beep and the LCD asks to enter the password again.
6. Press **Start/Enter**. The confidential document is printed. The documents in memory are erased after they are printed.

---

## Polling

### What is polling?

Polling means that one fax machine requests another to send a document. This is useful for sending unattended faxes. The person who wants to receive the document calls the machine holding the original and requests that the document be sent. In other words, it “polls” the machine holding the original document.

*Note: The remote machine must also support polling to use this feature.*

### Being polled by a remote machine (TX poll)

You can program your fax machine to send documents when polled by a remote fax machine. It is possible to assign a poll code to prevent unauthorized polling of your fax machine.

When you secure your machine using a poll code, only those who know the code can poll your machine.

1. Place the document face down in the automatic document feeder. If desired, adjust the resolution and contrast. for details, see page 2.8
2. Press **Menu**, then press **Polling** on the one-touch keypad. The display prompts you to choose one of the two polling options: 1.TX POLL and 2.DELAY RX POLL.
3. Press **Start/Enter** to confirm ‘1.TX POLL.’ The display prompts you to enter a 4-digit poll code.

*Note: The poll code is preset to 0000 at the factory. This setting represents no poll code.*

4. If you want to use a poll code, enter a 4-digit code.
5. Press **Start/Enter**.  
Or  
If you do not want to secure the transmission with a poll code, press **Start/Enter** when the display shows 0000 for TX-POLL CODE. If you previously entered a poll code, and do not want one, you may enter 0000 and then press **Start/Enter**.



6. The display prompts you to store the document in the machine bulletin board memory.

BULLENTI N ?

*Note: If you store the document in the bulletin board memory, more than one remote station can poll that document from your machine. If not, the file will be automatically erased after being polled by a remote machine.*

7. To store the document in the bulletin board memory, press **Start/Enter**.  
Or  
If you do not want the document to be stored in bulletin board memory, press **Stop**.
8. The machine stores the document in memory. The display shows a count of the number of pages being stored in memory and the remaining memory capacity.
9. The machine returns to standby mode and displays a reminder that a polling transmission is set. The machine automatically switches to FAX mode (automatic receiving) when set to be polled.

### **Adding documents to the job to be polled**

If you want to add documents to the original documents waiting in memory to be polled, follow the procedure below.

1. Place the additional documents face down into the automatic document feeder.
2. Press **Menu**, then press **Polling** on the one-touch keypad. The LCD displays the polling options.
3. Press **1** to select '**1.TX POLL**'.
4. The display prompts you to enter the poll code. The last used poll code is displayed.
5. Enter the **4-digit poll code** you had previously set, then press **Start/Enter**.  
The display prompts you to select '**1.ADD**' or '**2.CANCEL**'.
6. Press **1**. The machine scans the new documents into memory and returns to standby mode.

## Canceling a job already in memory which is waiting to be polled

If you want to cancel a job already in memory waiting to be polled, follow the procedure below.

1. Press **Menu**, then press **Add/Cancel** on the one-touch keypad. The LCD display prompts you to select 1.ADD or 2.CANCEL.
2. Press **2**.  
The set up information for the last entered polling job is displayed. If you have more than one polling job waiting in memory, press the **▲** or **▼** until the set up information for the job you wish to cancel is displayed.
3. Press **Start/Enter**.  
The display prompts ARE YOU SURE?
4. To cancel the polling job, press **1.YES**.  
The job is erased from memory and the machine returns to standby mode.

## Polling one or more remote machines (RX poll)

You can set up the machine to automatically receive documents from unattended remote fax machines. The machine can be set up to receive the fax now, or at a later time. This feature permits unattended polling in off-peak hours when telephone rates are lower.

*Note: The remote machine must also support polling to use this feature.*

1. Press **Menu**, then press **Polling** on the one-touch keypad. The display shows the polling options: 1.TX POLL and 2.DELAY RX POLL.
2. Press **2** to select 'DELAY RX POLL'. The display asks you to enter the number of the remote fax machine.
3. Enter the telephone number of the remote fax machine. There are several methods available to do this:
  - Direct entry of the telephone number using the numeric keypad
  - One-touch keypad dialing of stored telephone numbers (see one-touch dialing on page 2.31)
  - Speed number dialing using the numeric keypad (see speed dialing on page 2.33)

4. Press **Start/Enter**.
5. The display asks you to enter another fax number to receive documents from another location. If you want to receive documents from more than one location:
  - a) Press **Start/Enter** and enter another fax number using the numeric keypad, a one-touch button, or speed dial number  
The number appears in the display. Repeat steps 4 and 5 to receive document from other locations.
  - Or
  - b) If you have entered the last fax number, press **Stop**.
6. The display asks you to enter a name for the job. To assign a name to the polling job, enter the name. If a name is not desired, skip this step.
7. Press **Start/Enter**. The display asks you to enter a 4-digit poll code.
8. If the remote machine is secured with a poll code, you must enter the correct code, and press **Start/Enter**.  
Or  
If the remote machine is not secured with a poll code, press **Start/Enter** to accept [0000] which represents no code.
9. The display prompts for the time at which the machine will call and poll the remote machine. To call the remote machine immediately, skip over this step without entering a time for polling.  
Or  
If a specific time for polling is desired, enter the time. If you have configured your machine to use a 12-hour format, remember to specify AM or PM.  
  
***Note:** If you set a time earlier than the current time, your machine calls the number at that time on the following day.*
10. Press **Start/Enter**. If you did not enter a specific time for polling, the machine dials the remote immediately. If you entered a specific start time, the machine will call and poll the remote machine at that time.

# Making a copy

---

## Making a copy

The resolution is automatically set to SUPER FINE while the copy feature is in use, however, the contrast can be changed to produce the best copy quality for particular documents containing faint markings, dark image, photographs or other halftone images.

When you make a copy, your machine provides several option features you can choose as follows:

-**Multiple copies** : 1 to 99 copies of the document can be made.

-**Copy rate** : You can reduce or expand the image size by 1% increments from 50% to 200%.

-**Collation** : When COPY COLLATE menu is set to ON, the machine sorts the print job. For example, if you copy a three-page job to print 2 copies, the machine prints page3, page2, page1, page3, page2, page1.

To make a direct single copy without setting any options:

1. Load a document with the print side facing down. If necessary, adjust **Contrast** button to change the contrast. For details on the contrast, see page 2.8.
2. Press **Copy** twice or press **Copy** then **Start/Enter**. The machine starts copying.

### To set copy options:

1. Load a document with the print side facing down. If necessary, adjust **Contrast** button to change the contrast. For details on the contrast, see page 2.8.
2. Press **Copy**. The display asks you to enter the number of copies (1 to 99).

COPY  
[ 01-99] <01>

3. If you need two or more copies, enter the desired number using the dial keypad, then press ▼. You can also press ▼ without setting the number of copies. The display shows the next option; copy rate menu.

REDUCE/ENLARGE  
1: AUTO 2: MANUAL

4. If you want to reduce or enlarge the image size, press **2**, enter the number of the desired copy rate, then press ▼.

ENTER RATE  
[ 50-200] <100>

If not, press **1**.

5. The display asks you to choose how to collate. There are two ways to collate multiple copies; OFF and ON.

[ COPY COLLATE]  
1: ON 2: OFF

The 'OFF' is the stacking method. This will make 'n' copies of page one, 'n' copies of page two, and so on. These will all be stacked on top of each other. The second method 'ON' is the sorting method. This will make 1 copy of page 1, 2, 3, 4, in order, then makes a second copy of 1, 2, 3, 4 until a total of 'n' copies has been made.

**OFF (Group)**

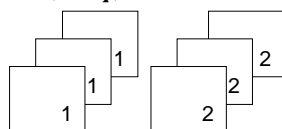

**ON (Sort)**

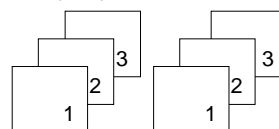

6. Press **1** or **2** to choose the desired collation method. You can also press ▼ without setting the collation (2:OFF is default value).
7. Press **Copy** to begin the copy operation.

**Note:** When setting the copy options, pressing the **Copy** will begin the copy operation immediately without displaying any remaining options.

# Automatic dialing

---

## One-touch dialing

One-touch dialing lets you use any one of the 20 one-touch buttons located on the left of the machine's control panel to automatically dial a number.

### Storing a number for one-touch dialing

1. Press and hold the one-touch button (01 through 20) for 2 seconds that you want to assign. The display shows `Txx`, where `xx` represents the selected one-touch button.
2. Enter the number (up to 46 digits) you want to store by using the number keypad, then press **Start/Enter**.

To insert a pause between numbers, press **Redial/Pause**; a '-' (hyphen) symbol appears in the display.

If you make a mistake while entering a number, use ◀ or ▶ to move the cursor under the wrong digit, then enter the correct digit, or press **Search/Delete**.

3. The display asks you to enter a name. Enter the desired name (up to 20 digits). For information on how to enter names, see page 2.4.

Or

If you don't want to assign a name, skip this step.

If you assign a name to the number, the name appears in the display when you press the one-touch button.

4. Press **Start/Enter** when the name appears correctly or without entering a name.
5. To set another one-touch number, press the desired one-touch button and repeat steps 2 through 5.  
Or  
To return to standby mode, press **Stop**.

### Using a one-touch number

1. Load a document you want to send a fax.
2. Press the one-touch button (01 through 20) to which you stored a number. The number will be automatically dialed, then the document begins to transmit when the remote fax machine answers the phone.

### Using one-touch label

A one-touch label sheet is included with your machine. As you store numbers in one-touch dial buttons, make a note of the numbers on the label to remind you which number is stored in each position.

1. Remove the clear cover and label using an instrument with a pointed end, as shown at right.

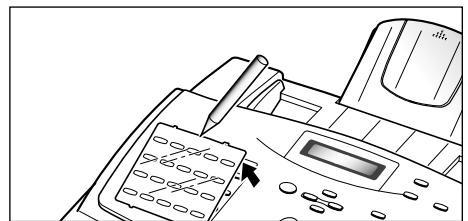

2. Write information on the label and replace the label and cover.

You may want to use pencil in case you wish to change these numbers later.

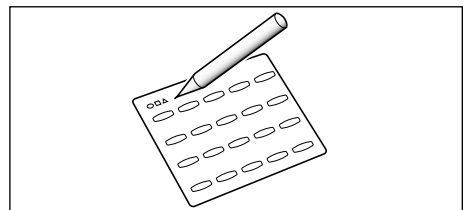

---

## Speed dialing

You can store up to 80 numbers in speed dial locations (1-80).

### Storing a number for speed dialing

1. Press and hold **Speed/Status** for 2 seconds.
2. Enter a speed dial location number to which you want to store a number, then press **Start/Enter**.

If a number is already stored in the location, the display shows the number in the upper line and 'ED:1 DEL:2 NXT:3' in the bottom line. Press **1** to edit that number, **2** to delete that number, or **3** to keep that number and choose another location.

3. Enter the number you want to store, then press **Start/Enter**.
4. To assign a name to the number, enter the desired name. For information on how to enter names, see page 2.4.  
Or  
If you don't want to assign a name, skip this step.
5. Press **Start/Enter** when the name appears correctly or without entering a name.
6. To store more telephone numbers, repeat steps 2 through 5.  
Or  
To return to standby mode, press **Stop**.

### Using a speed number

1. Load a document you want to send a fax.
2. Press **Speed/Status**, then enter a speed dial location number.
3. Press **Start/Enter** to dial the number. The number will be automatically dialed, and the document be transmitted when the remote fax machine answers the phone.



---

## Group dialing (for multi-address transmission)

Numerous one-touch and speed dial numbers can be registered as a Group. By using the Group number, you can send a document to multiple parties in a single operation. Your machine will dial the remote numbers in stored sequence. If the number is busy, your machine will dial the next stored number and after dialing all of the stored numbers, will automatically redial any number(s) which was/were previously busy. Before you can use this feature, you must coordinate and store Group numbers.

### Storing one-touch or speed dial numbers for group dialing

1. Press **Menu**, then press **Group Dial** on the one-touch keypad. The LCD display asks you to select 'SET' or 'EDIT'

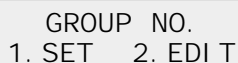

GROUP NO.  
1. SET 2. EDIT

2. Press **1** to select '1. SET'.
3. Enter a speed dial location number you want to use for group dial, then press **Start/Enter**.

The display asks you to press a one-touch button or enter a speed dial number you wish to include in the group.



ENTER ONE- TOUCH  
/ SPEED DI AL>\_

4. Press a one-touch button to which the fax number you wish to include in the group is stored.  
Or  
Enter a speed dial location number to which the fax number you wish to include in the group is stored.
5. Press **Start/Enter**. Repeat steps 4 and 5 to enter more destination numbers into the selected group.
6. Press **Stop** when you have entered all the desired destinations. The display asks you to enter a name.
7. To assign a name to the group, enter the desired name.  
Or  
If you don't want to assign a name, skip this procedure.
8. Press **Start/Enter**. If you want to store another group dial number, repeat steps 3 through 8.  
Or  
To return to standby mode, press **Stop**.

## Editing the one-touch or speed dial numbers in a group dial

After you have stored a group dial, you can edit a group dial at any time.

1. Press **Menu**, then press **Group Dial** on the one-touch keypad. The LCD display asks you to select 'SET' or 'EDIT'

```
GROUP NO.
1. SET  2. EDI T
```

2. Press **2** to select '2. EDIT'.
3. Enter a group number you want to edit when the machine displays 'ENTER GROUP NO.'.  
If you do not remember the group number, print the phone book.  
(See page 2.41.)

Follow one of the instructions below when the machine displays:

```
ENTER ONE- TOUCH
/ SPEED DI AL>_
```

4. Press a one-touch button or enter a speed dial location number you want add or delete.
5. Then display will shows 'ADD ?' or 'DELETE ?'.
  - 'ADD ?' for the number which is not included in a group dial.
  - 'DELETE ?' for the number which is included in a group dial already.
 If you want add or delete, press **Start/Enter**.
6. You can repeat steps 4 and 5 if you have more to add or delete.
7. Press **Stop** when you have finished, then the display asks you to enter a name.
8. To assign a name to the group, enter the desired name.  
Or  
If you don't want to assign a name, skip this procedure.
9. Press **Start/Enter**.  
If you want to edit another group dial number, repeat steps 3 through 8.  
Or  
To return to standby mode, press **Stop**.

## Assigning a group to a one-touch button

You can use a group number as one-touch dialing. Before you can use this feature, you must first register the group number (see 'Storing a number for one-touch dialing' on page 2.31), and then store the registered group number into an empty one-touch button.

1. Press and hold the one-touch button that you want to assign (01 through 20) for 2 seconds.
2. Press **Speed/Status** enter the group number, then press **Start/Enter**. The group number is stored in the selected one-touch button, and the display asks you to enter one-touch button for another group dial if you wish.
3. If you want to store another one-touch group dial numbers, repeat steps 1-3. If you want to return to standby mode, press **Stop**.

## Using group dialing (multi-address transmission)

You can use group dialing for memory transmission, or delayed transmission.

Follow the procedure of the desired operation (Memory transmission - p. 2.14, Delayed transmission - p. 2.12). When you come to a step in which the display requests you to enter the remote fax number, press the one-touch button to which you stored the group number. You can use only one group number at one operation. Then continue the procedure to complete the desired operation.

Your machine automatically scans the document loaded in the document tray into memory, and the machine will dial each of the numbers included in the group.

---

## Searching for a number in memory

There are two ways to search for a number in memory. You can either scan from A to Z sequentially, or you can search using the first letter of the name associated with the number.

### Searching sequentially through memory

1. Press **Search/Delete**, then press ▼ to move downward through the memory until you find the number you want. To move upward, press ▲.

Pressing ▼ allows you to search downward through the entire memory in alphabetical order (from A to Z), and ▲ allows you to search upward in reverse alphabetical order (from Z to A).

Each time you press ▼ or ▲, the display shows the next number stored in memory.

While searching through the machine's memory, you'll see that each entry is preceded by one of three letters: 'T' for one-touch dial, 'S' for speed, or 'G' for group dial number. These letters tell you how the number is stored.

2. When the number you want appears in the display, press **Start/Enter** to dial.

If a document is loaded, the document begins to be transmitted.

### Searching by the first letter

1. Press **Search/Delete**, then press the button labeled with the letter you want to search for. A name beginning with the letter appears in the display.

For example, if you want to find the name 'MOBILE,' press the '6' button, which is labeled with the letters 'MNO.'

2. Press ▲ or ▼ buttons to move through the memory until you find the name you want.
3. When the name and number you want appear, press **Start/Enter** to initiate dialing.

# *Other functions*

---

## **Using function buttons**

### **Redial**

#### **To redial the number last called**

Press **Redial/Pause**. If a document is loaded in the document tray, the machine automatically begins to send.

#### **To search through redial memory**

1. Press and hold **Redial/Pause** for 2 seconds. The redial memory in your machine retains the last 10 numbers called. If you have dialed the same number multiple times, the machine does not count the duplicates.
2. Press ▼ or ▲ to search through memory until you find the number you want.
3. When the number you want appears in the display, press **Start/Enter** to dial. If a document is loaded in the document tray, the machine automatically begins to send.

## Flash

Some special phone services require a switch-hook signal for proper operation. For example, if you have call waiting, you can put a call on hold and take a second call on the same line by pressing the switch-hook button. Pressing **Flash** performs the equivalent of a switch-hook operation.

1. When you are on the telephone and hear the call waiting signal, press **Flash** once. The first caller is on hold and you are speaking to the second caller.
2. Press **Flash** again to talk to the first caller again.

***Note:** If you do not have a special service that uses the switch-hook signal, don't press **Flash** during a call. If you do, you could disconnect the line.*

## Status

Your machine can perform more than one functions at a time. For example, you can simultaneously:

- Receive a fax into memory while making a copy.
- Store a fax document for later transmission while printing an incoming fax.
- Receive a fax into memory while printing a PC document.
- Print a PC document while sending a fax.

When the machine performs dual tasks, Press **Speed/Status** to toggle the display between the current operation and new operation.

---

## Printing reports

Your fax machine can print reports containing useful information - schedule job, system data, etc. The following reports are available:

### ***Help list***

This list shows the machine's basic functions and commands to use as a quick reference guide.

### ***Message confirmation report***

This report shows the fax number, the number of pages, elapsed time of the operation, the communication mode and the communication results.

You can set up your machine to print the message confirmation report (see page 2.42):

- Automatically after each transmission (ON)
- Automatically only if an error occurs during transmission (ERR)
- No report printed at all (OFF). You can print this report manually at any time you want.

### ***Schedule information list***

This list shows the document currently stored for delayed transmission, priority transmission, memory transmission, and TX polling. The list shows the starting time, type of operation, etc.

### ***Phone book***

This list shows all of the numbers currently stored in the fax machine's memory as one-touch dial numbers, speed dial numbers, and group dial numbers.

### ***System data list***

This list shows the status of the user-selectable options. After you change any setting, print this list to confirm your changes.

### ***Transmission or reception journal***

This report shows information concerning transmission or reception activities. It can be printed on command or programmed to print automatically after every 50 transmissions or receptions (see page 2.42).

### ***Multi-communication report***

This report is printed automatically after sending to or receiving from more than one location.

### ***Call back message***

This report is printed automatically when you do not respond to a remote operator's voice request.

### **Power failure report**

This report is printed automatically when data in memory was erased. This report shows data (if any) erased by the power failure.

***Note:** The list you have set to print automatically will not print when there is no paper loaded or a paper jam has occurred.*

### **To print list**

1. Press **Menu**.
2. Press the desired list button on the one-touch keypad.

On the one-touch keypad, press **Journal** for transmission or reception journal, **Help List** for help list, **TX Confirm** for message confirmation report, **Schedule Job** for schedule information list, **Phone Book** for telephone numbers list, **System List** for system data list.

The selected list will be printed out.

---

## **User Options**

Your fax machine has various user-selectable features. These options are preset at the factory, but you may select to change them. To find out how the options are currently set, print the System Data List. For more information on printing the list, see “To print list”.

### **Setting an Option**

1. Press **Menu**, then press **System Data** on the one-touch keypad.  
The display shows the first option menu.
2. Scroll through the options by pressing ▼ or ▲ repeatedly.
3. When the option you want appears in the display, enter the number for the desired status. Or, you can use ◀ or ▶ button to select the desired status, then press **Start/Enter** after choosing.

You can exit from setup mode at any time by pressing **Stop**. When you press **Stop**, the machine stores the options you’ve already changed and returns to standby mode.



## Selectable options

These instructions assume that you have followed the steps on page 2.41 under 'Setting an option' and that the machine is prompting you to change one of the options listed here.

- **PAPER SIZE**—Select the paper size you will use for the recording paper.  
Press **1** for letter (**LTR**), **2** for A4 size, or **3** to use legal (**LGL**) size paper.
- **MESSAGE CONF.**—A message confirmation report shows whether the transmission was successful or not, how many pages were sent, etc.  
Press **1** to print a confirmation report automatically each time you send a fax (**ON**).  
Press **2** to turn this feature off (**OFF**).  
Press **3** to print only when an error occurs and the transmission was not successful (**ERR**).
- **AUTO JOURNAL**—A journal shows specific information concerning transmission or reception activities, the time and dates of up to 50 of the most recent transmissions or receptions.  
Press **1** to print journal automatically after every 50 transmissions or receptions (**ON**).  
Press **2** to print journal manually (**OFF**).
- **REMOTE CODE**—The remote receive start code allows you to initiate fax reception from an extension phone plugged into the TEL jack on the back of your machine. If you pick up the extension phone and hear fax tones, enter the remote code and the machine will start receiving. The password is preset to \* 9 \* at factory.  
Enter the desired code 0 to 9 on the number keypad.
- **POWER SAVE** —The power saving menu item lets you reduce power usage when the printer is idle.  
Press **1** to turn the feature **ON**. The display asks you to determine the length of time the printer waits after a job is printed before it goes to a reduced power state:  
Press **1** for 5 minutes, **2** for 10 minutes, **3** for 15 minutes, **4** for 30 minutes, or **5** for 45 minutes.  
If your printer is used constantly, press **2** to turn the feature **OFF**. It keeps the printer ready to print with the minimum warm-up time.

- **ECM MODE (Error Correction Mode)**—This mode compensates for poor line quality and ensures accurate, error-free transmission with any other ECM-equipped facsimile machine. If the line quality is poor, transmission time may be increased when ECM is enabled.

Press **1** to turn the error correction mode on.

Press **2** to turn the error correction mode off.

- **RX REDUCTION**—When receiving a document as long as or longer than the paper installed in your machine, the machine can reduce the data in the document to fit onto your recording paper size.

Turn on this feature if you want to reduce an incoming page that may otherwise need to be divided into two pages with only a few centimeters on the second page. If the fax machine cannot reduce the data to fit into one page with the feature enabled, the data is divided and printed in actual size on two or more sheets if needed.

Press **1** to turn this feature on. Note that this feature does not apply to the copy mode.

Press **2** to turn this feature off. The overflow data will be printed out on a second page.

- **H. REDUCTION (Horizontal)**—If you turn the RX reduction feature on, you are allowed to set the horizontal reduction feature on or off. With horizontal reduction enabled, the machine will reduce an incoming page containing overflow data along the vertical axis only. The net effect of horizontal reduction will be a vertical compression of the image as shown below:

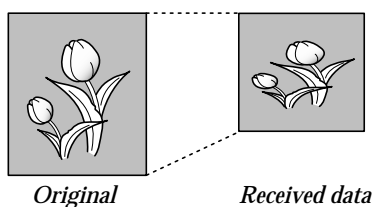

If you want to reduce incoming pages equally along both axes in order to maintain the proportionality of the original image, turn the horizontal reduction feature off. If you turn this feature off, the machine reduces the data as shown below.

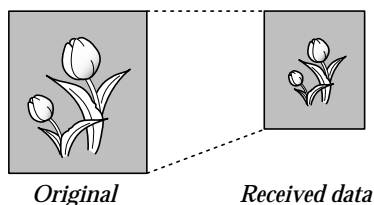

Press **1** to turn this feature on.

Press **2** to turn this feature off.

- **DISCARD SIZE**—When receiving or copying a document as long as or longer than the paper installed in your fax machine, you can set the fax machine to discard any excess image at the bottom of the page to fit into the recording paper size.

If the received page is outside the margin you set, it will be printed on two sheets of paper at the actual size.

If the data is within the margin, and the auto reduction feature is turned on, it will be reduced to fit into the appropriate size paper (discard does not take place). If the auto reduction feature is turned OFF or fails, the data within the margin will be discarded.

Enter the desired discard size using the number keypad, and press **Start/Enter**.

- **REDIAL INTERVAL**—Your machine can automatically redial a remote fax machine if it was busy or does not answer the first call.

Enter the number of minutes (from 01 to 15) using the number keypad.

- **REDIALS**—Enter the number of attempts (from 0 to 2) to redial the number before giving up.

If you enter 0, the machine will not redial.

- **ANSWER ON RING** —You can select the number of times your machine rings before answering an incoming call. If you are using your machine as both a telephone and a fax machine, we suggest you set the ring count to at least 4 to give you time to answer.

Enter a number from 1 through 7 on the number keypad.

- **DRPD (Distinctive Ring Pattern Detection) MODE**— 'Distinctive ring' is a telephone company service which enables a user to use a single telephone line to answer several different telephone numbers. The particular number someone uses to call you on is identified by different ringing patterns, which consist of various combinations of long and short ringing sounds. This feature is often used by answering services who answer telephones for many different clients and need to know which number someone is calling in on to properly answer the phone.

Using the distinctive ring pattern detection feature, your fax machine can 'learn' the ring pattern you designate to be answered as a fax machine. Unless you change it, this ringing pattern will continue to be recognized and answered as a fax call, and all other ringing patterns will be forwarded to the regular telephone or answering machine plugged into the TEL jack.

***Note :** Before using the distinctive ring pattern detection option, distinctive ring service must be installed on your telephone line by the telephone company. To set up distinctive ring pattern detection, you will need another telephone line at your location, or someone available to dial your fax number from outside.*

You can suspend or change distinctive ring pattern detection at any time.

Press **1** to turn this feature on.

Press **2** to turn this feature off.

Press **3** to setup the distinctive ring pattern detection. The LCD displays 'WAITING RING'. Call your fax number from another telephone. It is not necessary to place the call from a fax machine. When your machine begins to ring, do not answer the call. The machine requires several rings to learn the pattern.

When the machine completes 'learning', the LCD displays 'END DRPD SETUP'.

With the DRPD feature turned on, 'DRPD' appears in the display and the previously set reception mode is ignored. If you turn DRPD off, the machine returns to any previously set reception mode.

**Notes:**

- *DRPD must be set up again if you re-assign your fax number, or connect the machine to another telephone line.*
- *After DRPD has been set up, call your fax number again to verify that the machine answers with a fax tone, then have a call placed to a different number assigned to that same line to be sure the call is forwarded to the extension telephone or answering machine plugged into the TEL jack.*

- **SEND FROM MEMORY**—With this feature enables all transmission documents are automatically scanned into memory, and it will not be necessary to wait until documents in the ADF (Automatic Document Feeder) are sent out before you can send or store other fax jobs.

Press **1** to turn this feature on.

Press **2** to turn this feature off.

- **LOCAL ID**—This feature allows the machine to automatically print the page number, and the date and time of the reception at the bottom of each page of a received document.

Press **1** to turn this feature on.

Press **2** to turn this feature off.

- **CLOCK MODE**—This feature is to select the time format.

Press **1** to select 12 hour format.

Press **2** to select 24 hour format.

- **FLASH TIME**

Press **1** to select 100ms.

Press **2** to select 280ms.

Press **3** to select 600ms.

- **FAX COLLATE**—With this feature, the machine collates the received job.

Choose **ON** to turn this feature on.

Choose **OFF** to turn this feature off.

- **CALLER ID**—You can see the number of the person calling you (This option may not work when connected to a PABX).

Choose **ON** to turn on caller ID display.

Choose **OFF** to disable it.

Note that the RCV. START CODE is disabled when this caller ID option is on.

Before using the caller ID service, caller ID service must be installed on your telephone line by the telephone company.

## Maintenance

If you are getting streaks or spots on your print, you may run the maintenance.

### Cleaning drum

If print output quality decreases due to the presence of black streaks or ghost images appearing on printouts, drum cleaning should be performed as an attempt to rectify the problem.

1. Press **Menu**, then **Maintenance** on the one-touch keypad.  
'CLEAN DURM ?' appears in the display.
2. Press **Start/Enter**. The LCD display shows drum cleaning is under way.

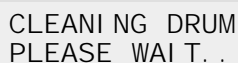

CLEANING DRUM  
PLEASE WAIT . .

The machine outputs a single sheet of paper containing any excess toner removed from the drum.

### Adjust shading

The Adjust shading feature allows you to recalibrate the baseline value the document scanner will interpret as white when scanning documents. This procedure should be performed after cleaning the document scanner, particularly if the white rubber roller remains stained after cleaning.

1. Press **Menu**, then **Maintenance** on the one-touch keypad.  
'CLEAN DRUM ?' appears in the LCD display.
2. Press **▲** or **▼** button. 'ADJUST SHADING ?' appears in the display.
3. Press **Start/Enter**. The LCD display prompts you to confirm your choice by pressing the appropriate number key.
4. Press **1**. The LCD display prompts you to load a sheet of white paper into the automatic document feeder.
5. Load a single sheet of white paper into the automatic document feeder.  
The machine immediately begins feeding the sheet of paper through the automatic document feeder. 'SHADING...' appears on the LCD display.
6. The machine returns to standby mode.

## Notify toner low

If you have set this notify toner low menu option to ON, when the toner cartridge needs to be replaced, your machine automatically sends a fax to your service company or the dealer to notify them that your machine requires a new toner cartridge. This feature will be activated only when the phone number of the service company or the dealer is stored in your machine's memory by technician. Ask your dealer for more information.

1. Press **Menu**, and **Maintenance** on the one-touch keypad.
2. Press ▲ or ▼ until you find 'NOTIFY TONER LOW', then press **Start/Enter**.
3. Press **1** or **2** to turn this feature ON or OFF, then press **Start/Enter**.
4. Press **Stop** to return to standby mode.





# *Troubleshooting*



# Troubleshooting

---

## Clearing jams

### Document jams while sending a fax

If a document jams while you are sending it, 'DOCUMENT JAM' appears in the display. Do not pull the document out of the slot, as this could harm your machine.

1. Open the control panel by hand.

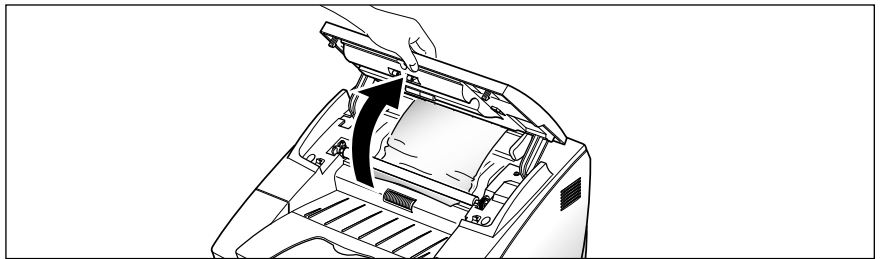

2. Flip up the control panel latch in front of the left side arm to hold the control Panel open.

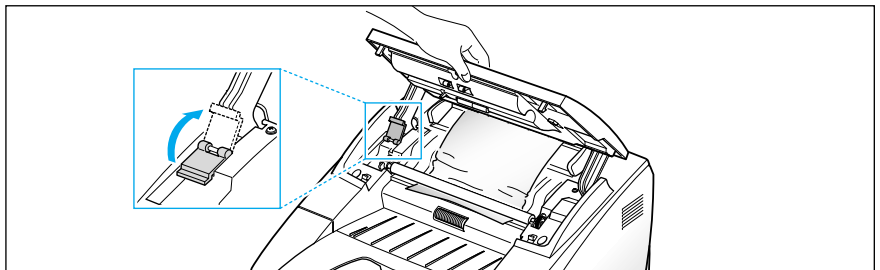

3. Carefully remove the jammed document. Then pull down the stopper and close the control panel firmly until it clicks into place.

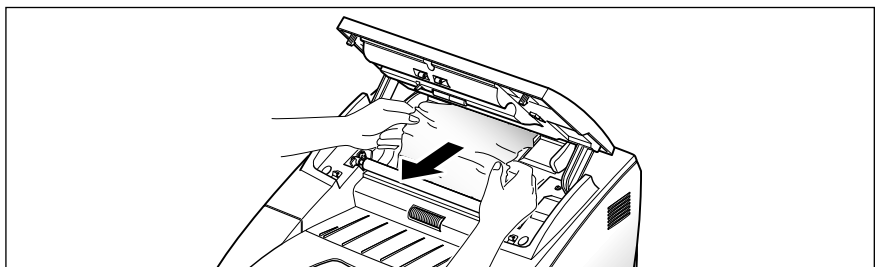

## Paper jams while the machine is printing

By carefully selecting paper type and loading paper properly, you should be able to avoid most paper jams. If a paper jam occurs, an error message appears in the display. Follow the steps below to clear the jam. To avoid tearing the paper, pull the jammed paper out gently and slowly.

### If jammed in the paper feed area (JAM 0)

1. Remove the recording paper cassette as shown below.

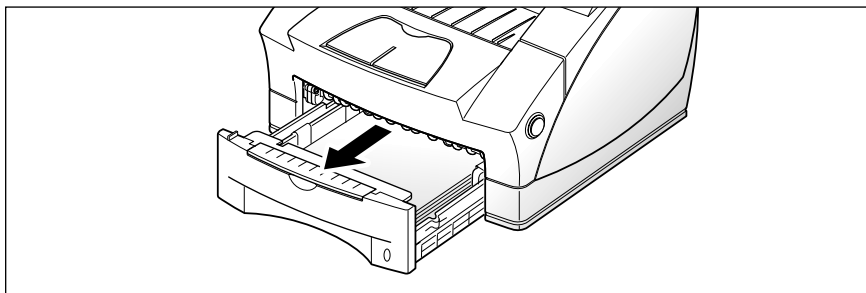

2. Carefully pull out the jammed paper.

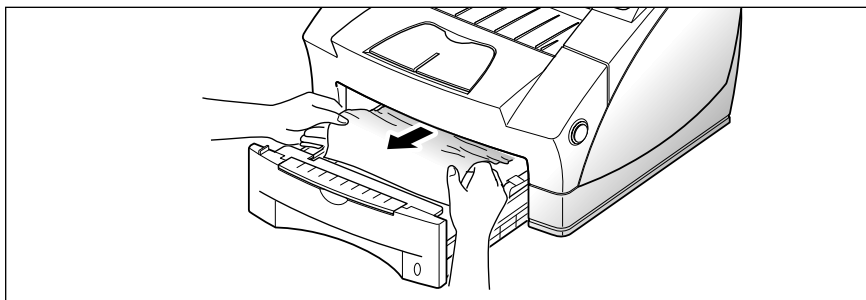

3. Replace the recording paper cassette.

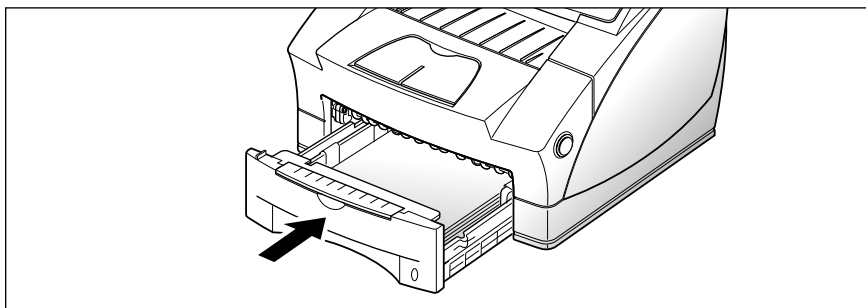

## If jammed inside the machine (JAM 1)

1. Pull the cover release button toward you and open the cover.

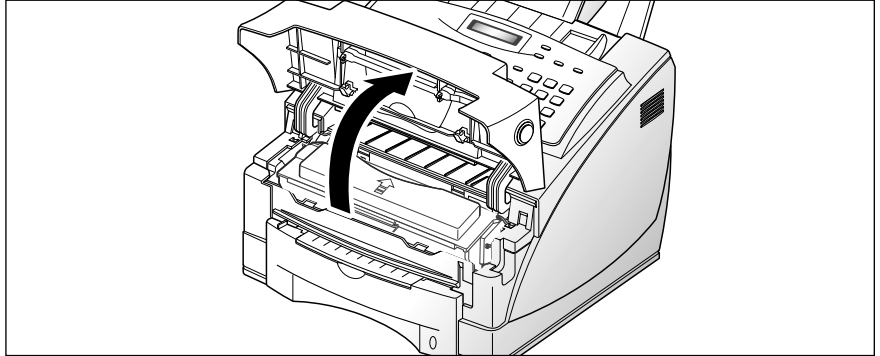

2. Remove the toner cartridge.

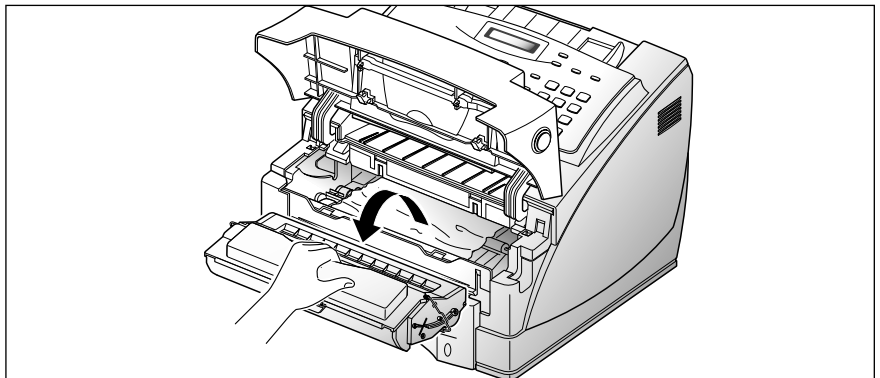

3. Gently pull the paper toward you.

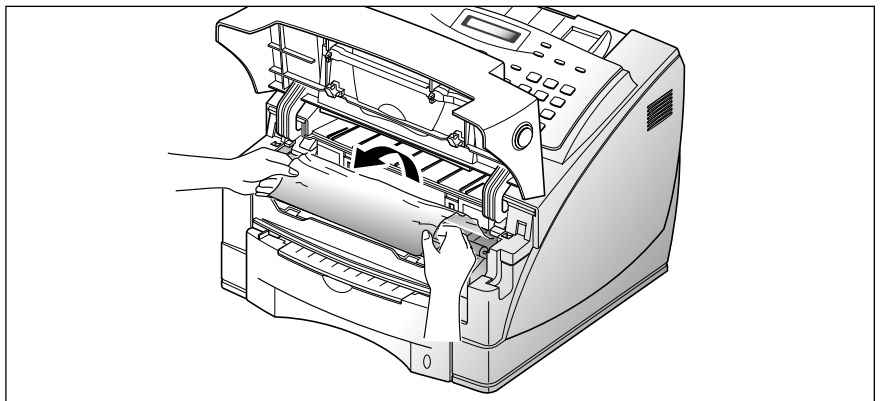

4. Check that there is no other paper in the machine.

5. Reinstall the toner cartridge and close the cover.

## If jammed in the printer output area (JAM 2)

1. If the paper jams as it exits to the printer exit tray and a long portion of the paper is visible, pull the paper straight out.

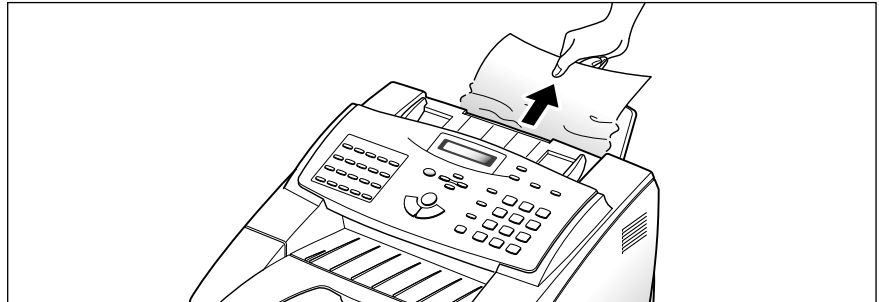

Stop pulling on the paper if you feel resistance, and the paper does not move immediately when you pull. Continue with the next step.

## Tips for avoiding paper jams

By carefully selecting print materials and loading them properly, you should be able to avoid most paper jams. If jams do occur, follow the steps outlined in “Clearing Jams” starting on page 3.2. If jams occur frequently, make sure that you are following these tips.

- Properly follow the procedures described in “Loading Paper into the cassette” on page 1.8. Make sure that the adjustable guides are positioned correctly.
- Do not overload the machine with paper. Make sure that only 250 sheets (20 lb) of paper are loaded at a time.
- Flex, fan and straighten the paper before loading it.
- Do not load wrinkled, creased, damp or highly curled paper.
- Do not mix paper types.
- Use only recommended print materials.
- Make sure that the recommended print side is facing up when loading the feeder.
- Keep print materials stored in an acceptable environment.

## LCD error messages

Display	Meaning	Solution
RETRY REDIAL?	The machine is waiting for the programmed interval to automatically redial a previously busy station.	You can press <b>Start/Enter</b> to immediately redial, or <b>Stop</b> to cancel the redial operation.
COMM. ERROR	A problem with facsimile communications has occurred.	A problem with the facsimile communications has occurred Try again.
INCOMPATIBLE	Remote party did not have the requested feature, such as polling. This also occurs if the remote machine has insufficient memory to complete the operation you are attempting.	Reconfirm your remote party's feature.
DOCUMENT JAM	The loaded document has jammed in the feeder.	Clear the document jam.
DOOR OPEN OR NO TONER CARTRIDGE	The cover is not securely latched, or the toner cartridge is not installed.	Press down on the cover until it clicks in place, or install the cartridge.
GROUP NOT AVAILABLE	You have tried to select a group location where only a single location number can be used.	
LINE ERROR	Your unit cannot connect with the remote machine, or has lost contact because of a problem on the phone line.	Try again. If failure persists, wait an hour or so for the line to clear, then try again. Or, turn the ECM mode on. See 'User options.'
LOAD DOCUMENT	You have attempted to set up a sending operation with no document loaded.	Load a document and try again.
MEMORY FULL	The memory is full.	Either delete unnecessary documents, or retransmit after more memory becomes available, or split the transmission into more than one operation.
NO ANSWER	The remote machine has not answered after all the redial attempts.	Try again. Make sure the remote machine is operational.

<b>Display</b>	<b>Meaning</b>	<b>Solution</b>
NO. NOT ASSIGNED	The one-touch or speed dial location you tried to use has no number assigned to it.	Dial the number manually with the keypad, or assign the number.
NO PAPER SUPPLY PAPER	The recording paper has run out.	Load the recording paper.
OVERHEAT	The printer part in your unit has overheated.	Please wait until it cools down. If you cannot solve the problem, please call service.
PAPER JAM 0 OPEN/CLOSE DOOR	Recording paper has jammed in paper feeding area.	Clear the jam.
PAPER JAM 1 OPEN/CLOSE DOOR	Recording paper has jammed inside the unit.	Clear the jam.
PAPER JAM 2 CHECK INSIDE	The jammed paper still remains inside the unit.	Clear the jam.
POLLING ERROR	The remote fax machine you want to poll is not ready to respond to your poll. Or When setting up to poll another fax machine, you have used an incorrect poll code.	The remote operator should know in advance that you are polling and have their fax unit loaded with the original document.  Enter the correct poll code.
TONER LOW	The toner is almost empty.	Take out the toner cartridge machine and gently shake it. By doing this, you can temporarily re-establish printing operations.
TONER EMPTY	The toner cartridge has run out . The machine stops.	Replace with a new toner cartridge.
FUSER ERROR	There occurs a problem in the fuser unit	Unplug the power cord and plug it in again. If you cannot solve the problem, please call service.
ENGINE ERROR	A problem has occurred in the LSU (Laser Scanning Unit)	Unplug the power code and plug it in again. If you cannot solve the problem, please call service.

---

## Fixing problems

Your problem may be listed on page 3.6 in the 'LCD error messages' section. Below are other problems you can solve by yourself. If not, call for service.

### *Fax problems*

Symptom	Cause and Solution
The machine is not working, there is no display and the buttons are not working.	<ul style="list-style-type: none"><li>• Unplug the power cord and plug it in again.</li><li>• Check your power socket is live.</li></ul>
No dial tone.	<ul style="list-style-type: none"><li>• Check that the phone line is connected properly.</li><li>• Check the phone socket in the wall by plugging in another phone.</li></ul>
The numbers stored in the memory do not dial correctly.	<ul style="list-style-type: none"><li>• Make sure that the numbers are stored in memory correctly.</li><li>• Print a telephone numbers list. See page 2.41.</li></ul>
The document does not feed into the machine.	<ul style="list-style-type: none"><li>• Make sure that the document is not wrinkled and you are putting it in correctly. Check the document is the right size, not too thick or thin.</li><li>• Make sure that the cover is firmly closed.</li></ul>
You cannot receive faxes automatically.	<ul style="list-style-type: none"><li>• The FAX or TEL/FAX mode should be selected.</li><li>• Is there paper in the machine?</li><li>• Check if the display shows 'MEMORY FULL.'</li></ul>
The machine cannot receive faxes manually.	<ul style="list-style-type: none"><li>• Did you hang up the handset before you pressed <b>Start/Enter</b> ?</li></ul> <p><i>Note: It will be applied when you have a phone connected to the TEL jack on the back of the machine.</i></p>
The machine will not send anything.	<ul style="list-style-type: none"><li>• Make sure that the document is loaded face down.</li><li>• 'TX' should show up in the display.</li><li>• Check the other machine you are sending to, to see if it can receive your fax.</li></ul>

Symptom	Cause and Solution
You cannot poll another machine.	<ul style="list-style-type: none"> <li>• The fax machine you are polling may be using a poll code.</li> </ul>
The fax you receive has got blank spaces or you received poor-quality copy.	<ul style="list-style-type: none"> <li>• The machine sending you the fax may be faulty.</li> <li>• The fax machine sending you a fax may have a dirty scan glass.</li> <li>• A noisy phone line can cause line errors.</li> <li>• Check your machine by making a copy.</li> <li>• The cartridge toner may be empty.</li> </ul>
Poor-quality copy	<ul style="list-style-type: none"> <li>• You may run the adjust shading in maintenance.</li> </ul>
Are some of the words on the fax you receive stretched?	<ul style="list-style-type: none"> <li>• The machine sending you the fax had a temporary document jam.</li> </ul>
There are lines on copies or documents you send.	<ul style="list-style-type: none"> <li>• Check your scan glass for marks, and clean it. See page 3.11.</li> </ul>
The machine dials a number, but fails to make a connection with another fax machine.	<ul style="list-style-type: none"> <li>• The other fax machine may be turned off, out of paper, or cannot answer incoming calls. Speak with the other machine operator and ask them to sort out the problem.</li> </ul>
You cannot store a document in memory.	<ul style="list-style-type: none"> <li>• There may not be enough memory to store the document. If the display shows a 'MEMORY FULL' message, delete any documents you no longer need from the memory, then restore the document.</li> </ul>
Blank areas appear at the bottom of each page or on other pages, with only a small strip of text printed at the top.	<ul style="list-style-type: none"> <li>• You may have chosen the wrong paper settings in the user options set up. See page 2.42 to choose the proper paper size.</li> </ul>



# Maintenance

---

## Clearing memory

You can selectively clear information stored in your machine's memory.

1. Press **Menu**, then press **Memory Clear** on the one-touch keypad.  
The display shows the options you can choose to clear.
  1. SYSTEM ID : your system ID number and name are cleared from the machine's memory.
  2. SYSTEM DATA : restores user-selectable options to the default value.
  3. PHONEBK&MEMORY : clears the one-touch, speed dial, or group dial numbers stored in memory. In addition, all the schedule job operations you have reserved are also canceled.

*Note : If there is received data in memory to be printed you cannot clear PHONEBK&MEMORY until printing it.*

4. TX-RX JOURNAL : clears all records of transmissions & receptions.
2. Move to the options by pressing **▲** or **▼** repeatedly until the option you want to clear is blinking.
3. Press **Start/Enter**. The display asks you to confirm your selection.
4. Press **1** to confirm. Or use **◀** or **▶** to choose 'YES', then press **Start/Enter**. The selected memory is cleared.

## Cleaning the document scanner

To keep your machine working properly, occasionally clean the white roller, ADF (automatic document feeder) rubber, and the scanning glass. If they are dirty, documents sent to another fax machine will not be clear.

1. Open the control panel with hand.

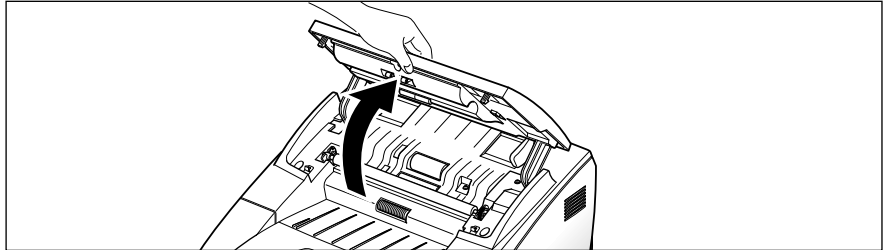

2. Flip up the control panel latch in front of the left side arm to hold the control panel open.

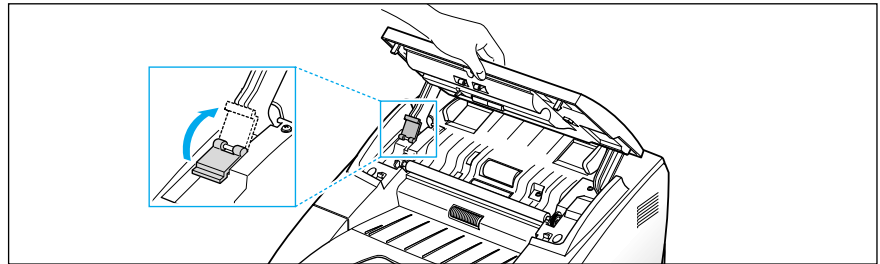

3. Disassemble the white roller as follows:  
Both ends of the white roller have plastic bushings that are snapped shut with small tabs on them. Pull the bushing slightly inward (A), then rotate the bushing (B) until it reaches a slot. Then pull the roller upward.

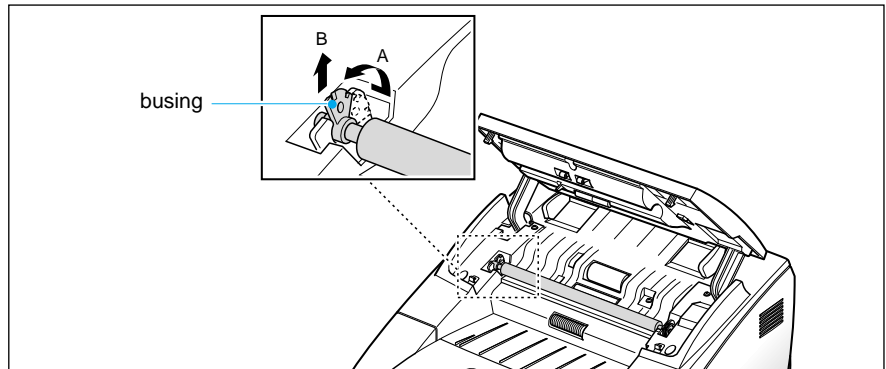

4. Wipe the roller surface with a soft cloth dampened with water.

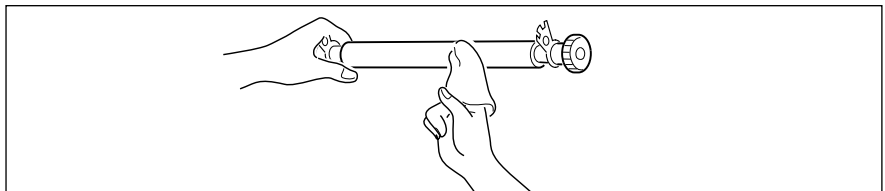

5. Clean the ADF (automatic document feeder) rubber piece.

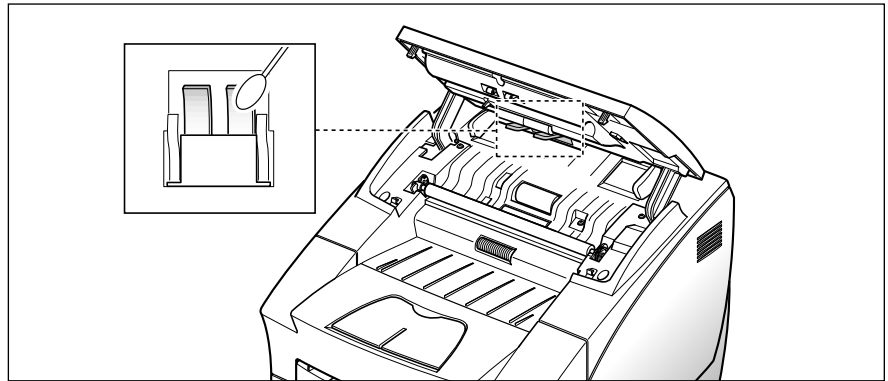

6. Carefully wipe the scanning glass with a soft, dry cloth.

If the glass is very dirty, first wipe it with a slightly dampened cloth, then with a dry cloth. Be very careful not to scratch the glass surface.

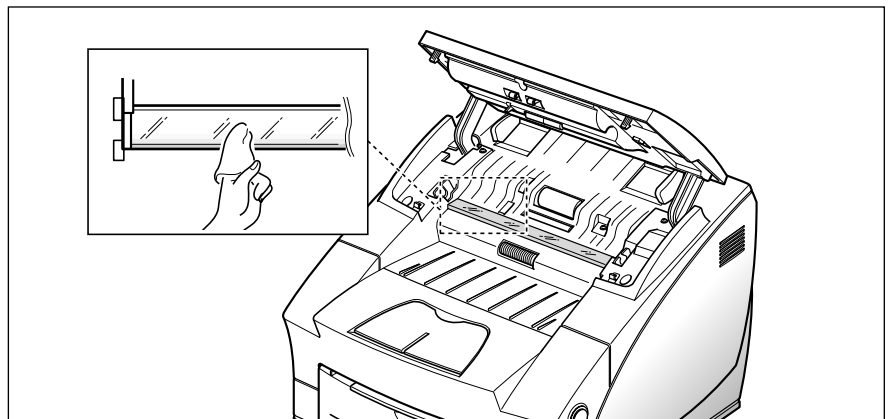

7. Replace the roller in reverse order, and then pull down the control panel latch and close the control panel firmly until it clicks into place.

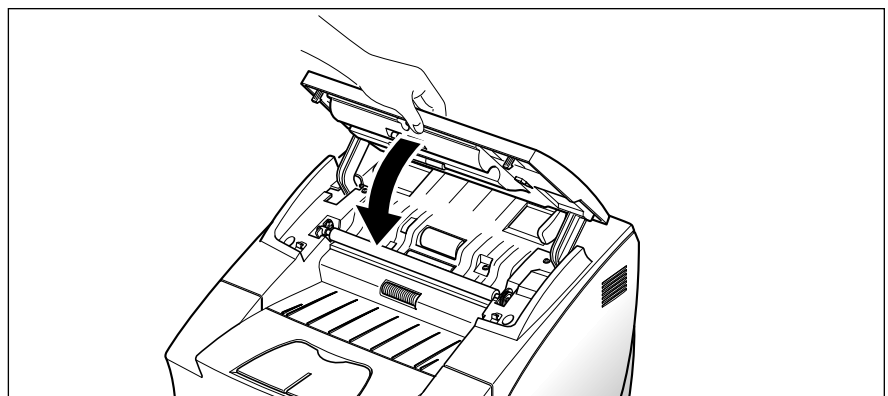

---

## Managing toner cartridge

### Expected cartridge life

The life of your toner cartridge depends on the amount of toner used in each print job. For instance, when you print a typical business letter with about 5% page coverage, you can expect a toner cartridge life of approximately 6,000 pages. The actual number may vary according to the print density of the page you print. If you print a lot of graphics, you may need to change the cartridge more often.

You can extend the life of your print cartridge by using the econo mode setting. Econo mode uses less toner than normal printing. The printed image is much lighter, and is adequate for printing drafts or proofs.

### Replacing toner cartridge

When the toner cartridge is near the end of its life, white streaks or hue changes will occur. You can temporarily re-establish print quality by redistributing the remaining toner in the cartridge.

1. Open the cover and remove the toner cartridge.
2. Gently shake the cartridge to distribute the toner evenly inside the cartridge.
3. Reinstall the cartridge and close the cover.

This is typically successful only one time. When the toner eventually runs out, white pages will be printed when a print job is sent, or when a fax is received. The print cartridge needs to be replaced. See the following page.

## To replace the toner cartridge:

1. Pull the cover release button toward you, open the machine cover.

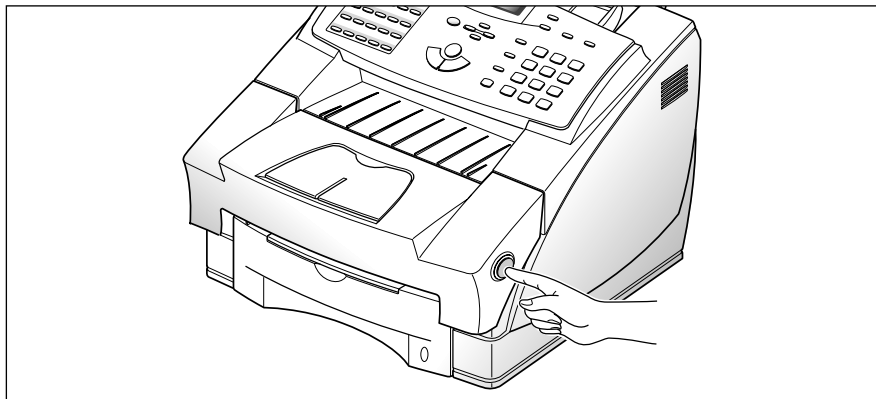

2. Remove the old toner cartridge. Follow the instructions printed on the cartridge box to recycle the used cartridge.

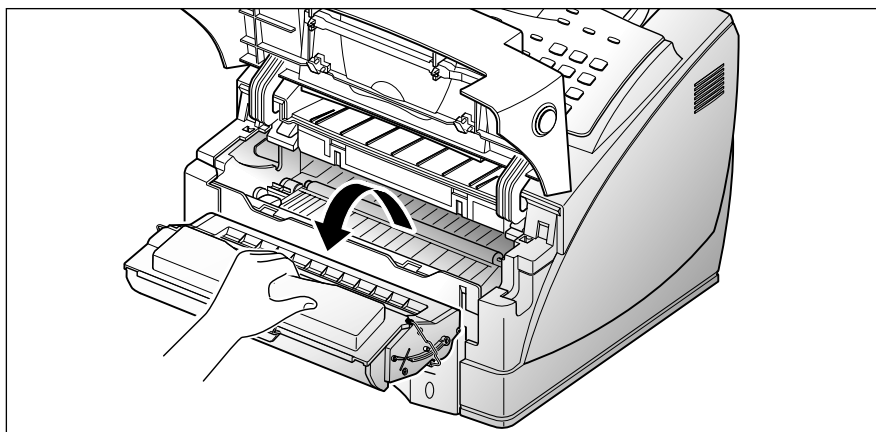

3. Install new toner cartridge, see page 1.5.



# ***Appendix***

## FCC regulations

This equipment has been tested and found to comply with the limits for a Class B digital device, pursuant to Part 15 of the FCC Rules. These limits are designed to provide reasonable protection against harmful interference in a residential installation. This equipment generates, uses and can radiate radio frequency energy and, if not installed and used in accordance with the instructions, may cause harmful interference to radio communications. However, there is no guarantee that interference will not occur in a particular installation. If this equipment does cause harmful interference to radio or television reception, which can be determined by turning the equipment off and on, the user is encouraged to try to correct the interference by one or more of the following measures:

- Reorient or relocate the receiving antenna.
- Increase the separation between the equipment and receiver.
- Connect the equipment to an outlet on a circuit different from that to which the receiver is connected.
- Consult the dealer or an experienced radio/TV technician for help.

Do not make any changes or modifications to the equipment unless specified in the manual. If such changes or modifications should be made, you could be required to stop operation of the equipment.

Use of shielded cable is required to comply with Class B limits in Subpart B of Part 15 of FCC Rules.

## Canadian radio interference regulations

This digital apparatus does not exceed the Class B limits for radio noise emissions from digital apparatus as set out in the interference-causing equipment standard entitled "Digital Apparatus", ICES-003 of the Industry and Science Canada.

Cet appareil numérique respecte les limites de bruits radioélectriques applicables aux appareils numériques de Classe B prescrites dans la norme sur le matériel brouilleur: "Appareils Numériques", NMB-003 édictée par l'Industrie et Sciences Canada.

# EC declaration of conformity

We,

SAMSUNG ELECTRONICS CO.,LTD  
#259, Gong Dan-Dong, Gumi-City, Kyung Buk, Korea

declare sole responsibility that the

SF-6800/SF-6750 Laser Facsimile  
Msys 6800/Msys 6750 Laser Facsimile

meets the intent of Directive 89/336/EEC for Electromagnetic Compatibility and Low Voltage Directive 73/23/EEC.

Compliance was demonstrated to the following specifications as listed in the official journal of the European Communities:

EN 50081-Emissions:

EN 55022 Radiated, Class B  
EN 55022 Conducted, Class B  
EN 60555-2 Power Harmonics

EN 50082-Immunity:

IEC 801-2 Electrostatic Discharge  
IEC 801-3 RF Radiated  
IEC 801-4 Fast Transient/Burst

EN 60950-Safety



## Laser safety statement

The printer is certified in the U.S. to conform to the requirements of DHHS 21 CFR subchapter J for class I(1) laser products, and elsewhere is certified as a class I laser product conforming to the requirements of IEC 825.

Class I laser products are not considered to be hazardous. The laser system and printer are designed so there is never any human access to laser radiation above a class I level during normal operation, user maintenance, or prescribed service condition.

**WARNING** Never operate or service the printer with the protective cover removed from the Laser/Scanner assembly. The reflected beam, although invisible, can damage your eyes.



CAUTION - INVISIBLE LASER RADIATION WHEN THIS COVER IS OPEN. DO NOT OPEN THIS COVER

VORSICHT - UNSICHTBARE LASERSTRAHLUNG, WENN ABDECKUNG GEÖFFNET. NICHT DEM STRAHL AUSSETZEN.

ATTENTION - RAYONNEMENT LASER INVISIBLE EN CAS D'OUVERTURE. DANGEREUSE AU FAISCEAU.

ATTENZIONE - RADIAZIONE LASER INVISIBILE IN CASO DI APERTURA. EVITARE L'ESPOSIZIONE AL FASCIO.

PRECAUCION - RADIACION LASER IVISIBLE CUANDO SE ABRE. EVITAR EXPONERSE AL RAYO.

ADVARSEL - USYNLIG LASERSTRÅLNING VED ÅBNING NÅR SIKKERHEDSBRYDERE ER UDE AF FUNKTION UNDGÅ UDSAETTELSE FOR STRÅLNING.

ADVARSER - USYNLIG LASERSTRÅLNING NÅR DEKSEL ÅPNES. STIRR IKKE INN I STRÅLEN. UNNGÅ EKSPONERING FOR STRÅLEN.

VARNING - OSYNLIG LASERSTRÅLNING NÅR DENNA DEL ÄR ÖPPAND OCH SPÄRREN ÄR URKOPPLAD. BETRAKTA EJ STRÅLEN STRÅLEN AR FARLIG.

VARO - AVATTAESSA JA SUOJALUKITUS OHITETTAESSA OLET ALTTIINA NÄKYMÄTTÖMÄLLE LASERSÄTEILYLLE ÄLÄ KATSO SÄTEESEEN.

Laser product label.

CLASS 1 LASER PRODUCT LASER KLASSE 1 LUOKAN 1 LASERLAITE APPAREIL À LASER DE CLASSE 1 TO IEC 825
--

## Safety information

### Product safety

USA	UL 1950 (UL LISTING)
CANADA	CSA C22.2 No. 950 & UL 1950 (CSA Certification)
EEC (Europe)	IEC 60950/EN 60950 (TÜV GS Certification)
CB	IEC 60950

### Laser safety

EEC (Europe)	HD 194. & EN 60825
USA	21 CFR, Chapter 1, Subchapter J (CDRH Certified)

## Power saver

This printer contains advanced energy conservation technology that reduces power consumption when it is not in active use.

When the printer does not receive data for an extended period of time, power consumption is automatically lowered. For potentially faster printing of the first page, you may turn the power save off from the Remote Control Panel setting.



The energy star emblem does not represent EPA endorsement of any product or service.

The equipment has been approved to [Commission Decision "CTR 21"] for pan-European single terminal connection to the Public Switched Telephone Network (PSTN). However, due to differences between the individual PSTNs provided in different countries the approval does not, of itself, give an unconditional assurance of successful operation on every PSTN network termination point.

In the event of problems, you should contact you contact your equipment supplier in the first instance.

# Specifications

Applicable line	Public Switched Telephone Network (PSTN) or behind PABX
Compatibility	CCITT Group 3
Data coding	MH/MR/MMR
Modem speed	14400/12000/9600/7200/4800/2400 bps
Transmission speed	Approx. 6 sec. (V.17 ECM: 14.4 kbps)
Effective scanning width	8.2 inches (208 mm)
Effective printing width	8.2 inches/letter, 202 mm/A4
Scanning method	Sheet-fed Contact Image Sensor (CIS)
Memory	3 MByte
Halftone	256 levels
Printing speed	8 PPM
Automatic document feeder	50 pages (based on 20 lb or 75 g/m <sup>2</sup> )
LCD	16 characters × 2 lines
Dimension (W × D × H)	15.19 × 15.94 × 10.62 inches (386 × 405 × 270 mm)
Weight	19.9 lb (9 Kg) with accessories 22.5lb (10.2 Kg)
Power requirements	120 VAC, 50/60 Hz
Power consumption	13 WH (sleep mode), 50 WH (Standby mode), 210 WH (Copy mode)
Environmental conditions	Temperature : 50°F to 86°F (10°C to 30°C) Humidity : 30% to 80% RH
Noise level	Standby : 36 dB, Printing : 47 dB, Scanning/Copying : 50 dB
Auto dialer	One-touch dialing (Registration for 20 numbers) Speed dialing (Registration for 80 numbers)
Document size – Width	5.8 to 8.5 inches (148 to 216 mm)
– Length	Single page : 5 to 59 inches (128 to 1,500 mm) Multi pages : 8.3 to 11.7 inches (279 to 297 mm)
– Weight (thickness)	Single page : 12.5 to 32 lb (50 to 100g/m <sup>2</sup> ) (0.07 to 0.15 mm) 20 pages: 12.5 to 28 lb (50 to 90g/m <sup>2</sup> ) (0.07 to 0.13 mm), Uncoated paper 50 pages : 20 lb (75g/m <sup>2</sup> ) (max 0.1 mm), Uncoated paper
Recording paper size	
– for automatic feeder	Letter : 8.5 × 11 inches (216 × 279 mm) A4 : 8.3 × 11.6 inches (210 × 297 mm) Legal : 8.5 × 14 inches (216 × 356 mm)
– for manual feeder	min. : 4 × 5.9 inches (98 × 148 mm)
Recording paper weight	
– for automatic feeder	16 to 24 lb (60 to 90 g/m <sup>2</sup> ) thickness : 0.085 to 0.11 mm
– for manual feeder	16 to 32 lb (60 to 120 g/m <sup>2</sup> )
Recording paper capacity	250 sheets; 20 lb (75g/m <sup>2</sup> ) weight. Other media : 1 sheet (OHP film)
Printing method	Laser Scanning Unit
Scanning density – Horizontal	300 dpi
– Vertical	Standard : 3.85 lines/mm (98 Lpi) Fine : 7.7 lines/mm (196 Lpi) Super fine : 11.8 lines/mm (300 Lpi), 15.4 lines/mm (392 Lpi)
Toner cartridge life	6,000 sheets @ 5 % coverage (A4, basic data) 7,200 sheets @ 4 % coverage (A4, calculated data)

# Index

## A

- adding documents • 2.16
- adjust speaker volume, setup • 1.22
- automatic dialing • 2.31
- automatic redial • 2.11

## B

- broadcasting • 2.14

## C

- call back message • 2.40
- caller ID • 2.46
- canceling a standby operation • 2.16
- cartridge • 1.5
- connection
  - extension phone • 1.15
  - telephone line • 1.15
  - power cord • 1.16
- contrast
  - button, location • 2.3
  - setting • 1.18 2.8
- control panel • 2.2
- copy • 2.29

## D

- date and time, setting • 1.22
- delayed transmission • 2.12
- discard size • 2.44
- document
  - jam, clearing • 3.2
  - loading • 2.9
- document exit tray, setup • 1.17
- document tray, setup • 1.16

## E

- editing
  - group dial • 2.35
  - number or name • 1.23
  - one-touch dial number • 2.31
  - speed dial number • 2.33
- error message • 3.6
- extension phone
  - connection • 1.15

## F

- fax
  - receiving mode • 2.17
  - problems • 3.8
  - receiving • 2.17
  - sending • 2.7
- flash • 2.39

## G

- group dial • 2.34
  - editing • 2.35
  - sending • 2.36
  - storing • 2.34

## H

- help list • 2.40

## **J**

- jam, clearing
  - document • 3.2
  - paper • 3.3
- journal, print • 2.40

## **K**

- key sound, setup • 1.20

## **L**

- language, select • 1.21
- list, print • 2.40
- LCD, location • 2.2
- loading
  - paper • 1.8
  - document • 2.9

## **M**

- mail box • 2.21
- maintenance
  - adjust shading • 2.47
  - clean drum • 2.47
  - notify toner low • 2.48
- memory, clearing • 3.10
- multi-communication report • 2.40

## **N**

- name, setting • 1.23 2.4
- number
  - fax, setting • 1.23
  - group dial • 2.34
  - keypad, using • 2.4
  - one-touch dial • 2.31
  - speed dial • 2.33

## **O**

- one-touch dial
  - sending • 2.32
  - storing • 2.31
- opc drum, clean • 2.47

## **P**

- paper
  - jam, clearing • 3.3
  - loading • 1.8
- pause • 2.6
- phonebook • 2.40
- polling • 2.25
- power cord, connection • 1.16
- power failure report • 2.41
- power save mode • 2.42
- priority transmission • 2.15

## **R**

- receiving
  - in ans/fax mode • 2.19
  - in fax mode • 2.18
  - in tel/fax mode • 2.18
  - in tel mode • 2.19
  - mode • 2.17
  - polling • 2.25
  - reception journal • 2.40
- redial • 2.38
- report, printing • 2.40
- resolution
  - button, location • 2.3
  - setting • 1.18 2.8
- ringer volume, adjusting • 1.18

## S

### sending

- automatically • 2.10
- broadcasting • 2.14
- delay TX • 2.12
- priority TX • 2.15
- polling • 2.25

### setup

- document exit tray • 1.17
- document tray • 1.16
- system • 1.18

### shading, adjust • 2.47

### speaker volume, adjusting • 1.22

### speed dial

- sending • 2.33
- storing • 2.33

### system data list • 2.40

### system setup

- answer on ring • 2.44
- auto journal • 2.42
- caller ID • 2.46
- clock mode • 2.46
- discard size • 2.44
- DRPD • 2.45
- ECM mode • 2.43
- fax collate • 2.46
- flash time • 2.46
- local ID • 2.46
- message confirm • 2.42
- paper size • 2.42
- power save • 2.42
- redials • 2.44
- redial interval • 2.44
- remote code • 2.42
- rx reduction • 2.43
- send from memory • 2.46

## T

### telephone line, connection • 1.15

### toner cartridge

- installing • 1.5
- replacing • 3.13

## U

### unpacking • 1.2

## V

### voice request • 2.11

### volume, adjusting

- key • 1.20
- ringer • 1.18
- speaker • 1.22







## Free Manuals Download Website

<http://myh66.com>

<http://usermanuals.us>

<http://www.somanuals.com>

<http://www.4manuals.cc>

<http://www.manual-lib.com>

<http://www.404manual.com>

<http://www.luxmanual.com>

<http://aubethermostatmanual.com>

Golf course search by state

<http://golfingnear.com>

Email search by domain

<http://emailbydomain.com>

Auto manuals search

<http://auto.somanuals.com>

TV manuals search

<http://tv.somanuals.com>