

SAMSUNG

PCJ532RF/PCJ533RF
PCJ534RF/PCJ611RF
PCJ614RF/PCK5315R
PCK6115R

COLOR TELEVISION



**Owner's
Instructions**

AA68-00583F(ENG)

Warning! Important Safety Instructions



CAUTION: TO REDUCE THE RISK OF ELECTRIC SHOCK, DO NOT REMOVE COVER (OR BACK). NO USER SERVICEABLE PARTS INSIDE. REFER SERVICING TO QUALIFIED SERVICE PERSONNEL.

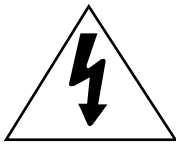

This symbol indicates high voltage is present inside. It is dangerous to make any kind of contact with any inside part of this product.



This symbol alerts you that important literature concerning operation and maintenance has been included with this product.

Note to CATV system installer: This reminder is provided to call CATV system installer's attention to Article 820-40 of the National Electrical Code (Section 54 of Canadian Electrical Code, Part I), that provides guidelines for proper grounding and, in particular, specifies that the cable ground shall be connected to the grounding system of the building as close to the point of cable entry as practical.

Caution: FCC/CSA regulations state that any unauthorized changes or modifications to this equipment may void the user's authority to operate it.

Caution: To prevent electric shock, match the wide blade of plug to the wide slot, and fully insert the plug.

Attention: pour éviter les chocs électriques, introduire la lame le plus large de la fiche dans la borne correspondante de la prise et pousser jusqu'au fond.

Important: One Federal Court has held that unauthorized recording of copyrighted TV programs is an infringement of U.S. copyright laws. Certain Canadian programs may also be copyrighted and any unauthorized recording in whole or in part may be in violation of these rights.

To prevent damage which may result in fire or electric shock hazard, do not expose this appliance to rain or moisture.

Thank You for Choosing Samsung

Thank you for choosing Samsung! Your new Samsung Projection TV represents the latest in television technology. We designed it with easy-to-use on-screen menus and closed captioning capabilities, making it one of the best products in its class. We are proud to offer you a product that will provide convenient, dependable service and enjoyment for years to come.

Important Safety Information

 Always be careful when using your TV receiver. To reduce the risk of fire, electrical shock, and other injuries, keep these safety precautions in mind when installing, using, and maintaining your machine.

- Read all safety and operating instructions before operating your TV.
- Keep the safety and operating instructions for future reference.
- Heed all warnings on the TV receiver and in the operating instructions.
- Follow all operating and use instructions.
- Unplug the TV receiver from the wall outlet before cleaning. Use a damp cloth; do not use liquid or aerosol cleaners.
- Never add any attachments and/or equipment without approval of the manufacturer. Such additions can increase the risk of fire, electric shock, or other personal injury.
- Do not use the TV receiver where contact with or immersion in water is a possibility, such as near bath tubs, sinks, washing machines, swimming pools, etc.
- Do not place the TV on an unstable cart, stand, tripod, bracket, or table where it can fall. A falling TV can cause serious injury to a child or adult, and serious damage to the appliance. Use only with a cart, stand, tripod, bracket, or table recommended by the manufacturer or sold with the TV. Follow the manufacturer's instructions when mounting the unit, and use a mounting accessory recommended by the manufacturer. Move the TV and cart with care. Quick stops, excessive force, and uneven surfaces can make the unit and cart unsteady and likely to overturn.
- Provide ventilation for the TV receiver. The unit is designed with slots in the cabinet for ventilation to protect it from overheating. Do not block these openings with any object, and do not place the TV receiver on a bed, sofa, rug, or other similar surface. Do not place it near a radiator or heat register. If you place the TV receiver on a rack or bookcase, ensure that there is adequate ventilation and that you've followed the manufacturer's instructions for mounting.
- Operate your TV receiver only from the type of power source indicated on the marking label. If you are not sure of the type of power supplied to your home, consult your appliance dealer or local power company.
- Use only a grounded or polarized outlet. For your safety, this TV is equipped with a polarized alternating current line plug having one blade wider than the other. This plug will fit into the power outlet only one way. If you are unable to insert the plug fully into the outlet, try reversing the plug. If the plug still does not fit, contact your electrician to replace your outlet.



- Protect the power cord. Power supply cords should be routed so that they won't be walked on or pinched by objects placed on or against them. Pay particular attention to cords at plugs, convenience receptacles, and the point where they exit from the unit.
- Unplug the TV from the wall outlet and disconnect the antenna or cable system during a lightning storm or when left unattended and unused for long periods of time. This will prevent damage to the unit due to lightning and power-line surges.
- Avoid overhead power lines. An outside antenna system should not be placed in the vicinity of overhead power lines or other electric light or power circuits or where it can fall into such power lines or circuits. When installing an outside antenna system, be extremely careful to keep from touching the power lines or circuits. Contact with such lines can be fatal.
- Do not overload the wall outlet or extension cords. Overloading can result in fire or electric shock.
- Do not insert anything through the openings in the unit, where they can touch dangerous voltage points or damage parts. Never spill liquid of any kind on the TV.
- Ground outdoor antennas. If an outside antenna or cable system is connected to the TV, be sure the antenna or cable system is grounded so as to provide some protection against voltage surges and built-up static charges. Section 810 of the National Electrical Code, ANSI/NFPA No.70-1984, provides information about proper grounding of the mast and supporting structure, grounding of the lead-in wire to an antenna discharge unit, size of grounding conductors, location of antenna discharge unit, connection to grounding electrodes, and requirements for the grounding electrode.

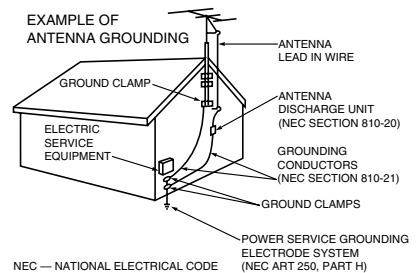

- Do not attempt to service the TV yourself. Refer all servicing to qualified service personnel. Unplug the unit from the wall outlet and refer servicing to qualified service personnel under the following conditions:
 - when the power-supply cord or plug is damaged
 - if liquid has been spilled on the unit or if objects have fallen into the unit
 - if the TV has been exposed to rain or water
 - if the TV does not operate normally by following the operating instructions
 - if the TV has been dropped or the cabinet has been damaged
 - when the TV exhibits a distinct change in performance
- If you make adjustments yourself, adjust only those controls that are covered by the operating instructions. Adjusting other controls may result in damage and will often require extensive work by a qualified technician to restore the TV to normal.
- When replacement parts are required, be sure the service technician uses replacement parts specified by the manufacturer or those that have the same characteristics as the original part. Unauthorized substitutions may result in additional damage to the unit.
- Upon completion of any service or repairs to this TV, ask the service technician to perform safety checks to determine that the TV is in a safe operating condition.

This device complies with part 15 of the FCC Rules. Operation is subject to the following two conditions:

- (1) This device may not cause harmful interference, and**
- (2) This device must accept any interference that may cause undesired operation.**

This television receiver provides display of television closed captioning in accordance with §15.119 of the FCC rules.

FCC Information

User Instructions

The Federal Communications Commission Radio Frequency Interference Statement includes the following warning:

NOTE: This equipment has been tested and found to comply with the limits for a Class B digital device, pursuant to Part 15 of the FCC Rules. These limits are designed to provide reasonable protection against harmful interference in a residential installation. This equipment generates, uses, and can radiate radio frequency energy and, if not installed and used in accordance with the instructions, may cause harmful interference to radio communications. However, there is no guarantee that interference will not occur in a particular installation.

If this equipment does cause harmful interference to radio or television receptions, which can be determined by turning the equipment off and on, the user is encouraged to try to correct the interference by one or more of the following measures:

- Reorient or relocate the receiving antenna.
- Increase the separation between the equipment and receiver.
- Connect the equipment into an outlet on a circuit different from that to which the receiver is connected.
- Consult the dealer or an experienced radio/TV technician for help.

User Information

Changes or modifications not expressly approved by the party responsible for compliance could void the user's authority to operate the equipment.

If necessary, consult your dealer or an experienced radio/television technician for additional suggestions. You may find the booklet called How to Identify and Resolve Radio/TV Interference Problems helpful. This booklet was prepared by the Federal Communications Commission. It is available from the U.S. Government Printing Office, Washington, DC 20402, Stock Number 004-000-00345-4.

Warning

User must use shielded signal interface cables to maintain FCC compliance for the product.

Declaration of conformity for products marked with FCC Logo. This device complies with Part 15 of the FCC Rules.

Operation is subject to the following two conditions:
(1) this device may not cause harmful interference, and
(2) this device must accept any interference received, including interference that may cause undesired operation.

The party responsible for product compliance:

SAMSUNG ELECTRONICS CO., LTD
America QA Lab of Samsung
85 West Tasman Drive
San Jose, CA 95134 USA
Tel) 408-544-5124
Fax) 408-544-5191

Provided with this monitor is a detachable power supply cord with IEC320 style terminations. It may be suitable for connection to any UL Listed personal computer with similar configuration. Before making the connection, make sure the voltage rating of the computer convenience outlet is the same as the monitor and that the ampere rating of the computer convenience outlet is equal to or exceeds the monitor voltage rating. For 120 Volt applications, use only UL Listed detachable power cord with NEMA configuration 5-15P type (parallel blades) plug cap. For 240 Volt applications use only UL Listed Detachable power supply cord with NEMA configuration 6015P type (tandem blades) plug cap.

IC Compliance Notice

This Class B digital apparatus meets all requirements of the Canadian Interference-Causing Equipment Regulations of ICES-003.

Notice de Conformité IC

Cet appareil numérique de classe B respecte toutes les exigences du Règlement ICES-003 sur les équipements produisant des interférences au Canada.

MPR II Compliance

This monitor complies with SWEDAC (MPR II) recommendations for reduced electric and magnetic fields.

European Notice

Products with the CE Marking comply with both the EMC Directive (89/336/EEC), (92/31/EEC), (93/68/EEC) and the Low Voltage Directive (73/23/EEC) issued by the Commission of the European Community. Compliance with these directives implies conformity to the following European Norms:

- EN55022 (CISPR 22) – Radio Frequency Interference
- EN50082-1 : 1992 – Electromagnetic Immunity
- EN60555-2 (IEC555-2) – Power Line Harmonics
- EN60555-3 (IEC555-3) – Voltage Fluctuations
- EN60950 (IEC950) – Product Safety.

Chapter 1: Your New TV	1.1
List of Features	1.1
Familiarizing Yourself with Your New TV	1.2
Front Panel Buttons	1.2
Front Panel Jacks	1.3
Rear Panel Jacks	1.4
Remote Control	1.5
Chapter 2: Installation	2.1
Connecting VHF and UHF Antennas	2.1
Antennas with 300-ohm Flat Twin Leads	2.1
Antennas with 75-ohm Round Leads	2.2
Separate VHF and UHF Antennas.	2.2
Connecting Cable TV	2.2
Cable without a Cable Box	2.2
Connecting to a Cable Box that Descrambles All Channels.	2.3
Connecting to a Cable Box that Descrambles some Channels.	2.3
Connecting a VCR	2.4
Connecting an S-VHS VCR.	2.5
Connecting a Second VCR to Record from Your TV	2.6
Connecting a Camcorder	2.7
Installing Batteries in the Remote Control.	2.8
Chapter 3: Operation	3.1
Turning the TV On and Off.	3.1
Adjusting basic convergence	3.1
Adjust Red Convergence	3.2
Adjust Blue Convergence	3.2
Viewing the Menu and On-Screen Displays.	3.3
Viewing the Menu.	3.3
Viewing the Display	3.3
Selecting a Menu Language.	3.4
Memorizing the Channels.	3.5
Selecting the Video Signal-source	3.5
Storing Channels in Memory (Automatic Method)	3.6
Adding and Erasing Channels (Manual Method)	3.7
Changing Channels	3.7
Using the Channel Buttons.	3.7
Directly Accessing Channels.	3.7
Setting the Clock	3.8
Adjusting the Volume	3.9
Using Mute.	3.9
Customizing the Picture	3.10
Using Automatic Picture Settings	3.11
Customizing the Sound	3.12
Using Automatic Sound Settings.	3.13
Viewing a VCR or Camcorder Tape.	3.14

Chapter 4: Special Features	4.1
Customizing Your Remote Control	4.1
Setting Up Your Remote Control to Operate Your VCR or DVD	4.1
Setting Up Your Remote Control to Operate Your Cable Box.	4.2
Setting the On/Off Timer	4.4
Setting the Sleep Timer.	4.5
Viewing Closed Captions	4.6
Fine Tuning Channels.	4.7
LNA(Low Noise Amplifier)	4.8
Special Audio Options: Dolby Surround, MTS, and Headphones	4.9
Dolby Prologic	4.9
Dolby 3D Phonic	4.10
Choosing a Multi-Channel Sound (MTS) Soundtrack.	4.11
Using Wireless Headphones	4.12
Setting up Wireless Headphones with Picture-in-Picture.	4.12
Viewing Picture-in-Picture	4.13
Activating Picture-in-Picture.	4.13
Selecting a Signal Source (Antenna or Cable) for PIP	4.14
Selecting a Signal Source (External A/V) for PIP	4.14
Swapping the Contents of the PIP image and Main image	4.14
Changing the PIP Channel	4.15
Changing the Location (Rotating) the PIP Window	4.15
Freezing the PIP Image.	4.15
Changing the Size of the PIP Window	4.15
Scanning the Available Channels	4.15
Using the V-Chip	4.16
Setting Up Your Personal ID Number (PIN)	4.16
How to Enable/Disable the V-Chip.	4.17
How to Set up Restrictions Using the “TV guidelines”	4.17
How to Set up Restrictions using the MPAA Ratings: G, PG, PG-13, R, NC-17, X	4.19
How to Reset the TV after the V-Chip Blocks a Channel (“Emergency Escape”)	4.20
 Chapter 5: Troubleshooting	 5.1
Identifying Problems	5.1
 Appendix	 A.1
Cleaning and Maintaining Your TV.	A.1
Using Your TV in Another Country	A.1
Specifications	A.1

Chapter One

YOUR NEW TV

List of Features

Your Samsung TV was designed with the latest technology. This TV is a high-performance unit that includes the following special features:

- Easy-to-use remote control
- Easy-to-use on-screen menu system
- Automatic timer to turn the TV on and off
- Adjustable picture and sound settings that can be stored in the TV's memory
- Automatic channel tuning for up to 181 channels
- A special filter to reduce or eliminate reception problems
- Fine tuning control for the sharpest picture possible
- A built-in multi-channel sound decoder for stereo and bilingual listening
- Built-in, dual channel speakers (20 watts per channel)
- A special sleep timer
- Picture-in-Picture
- Headphone jack for private listening
- 16:9 letter box format available depending upon source

Familiarizing Yourself with The TV

Front Panel Buttons

The buttons on the front panel control your TV's basic features, including the on-screen menu. To use the more advanced features, you must use the remote control.

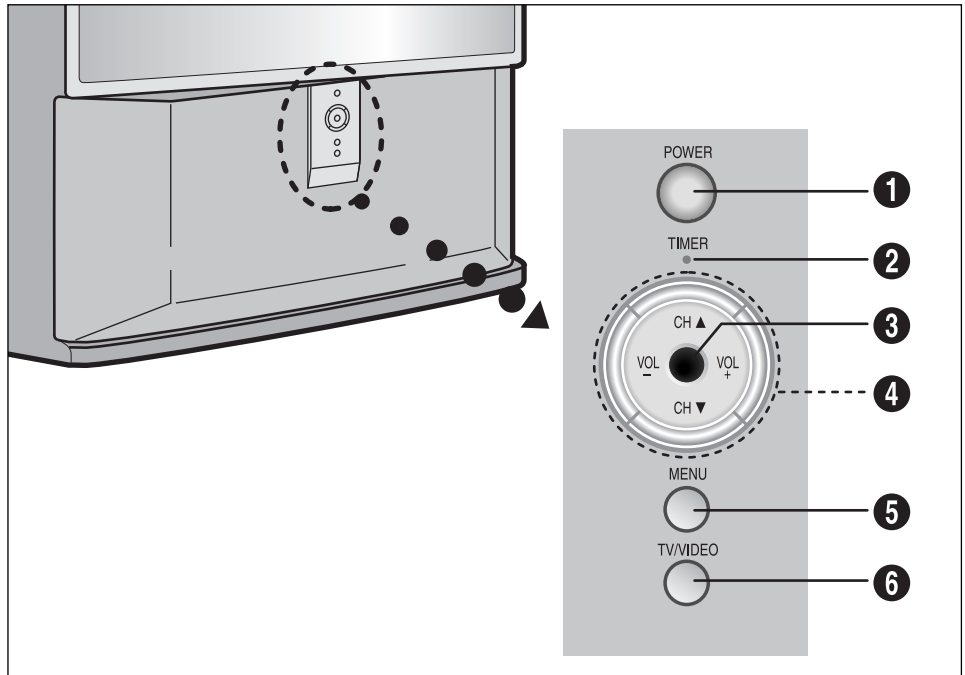

1 POWER

Press to turn the TV on and off.

2 TIMER indicator

When the TV is turned on, the TIMER indicator blinks ten times. This indicator illuminates when the TIMER mode is set to the "On" position after setting the clock and either the On timer or Off timer, with the remote control. Even if the power is turned off, this indicator stays lit. (Clock must be set before using this function.)

3 Remote Control Sensor

Aim the remote control towards this spot on the TV.

4 VOLUME -, +

Press to increase or decrease the volume. Also used to select items on the on-screen menu.

CH ▼ and CH ▲

Press to change channels. Also press to highlight various items on the on-screen menu.

5 MENU

Press to see an on-screen menu of your TV's features.

6 TV/VIDEO

Press this button to display a menu of all the available signal sources. When the menu appears, use the CH buttons to highlight a particular source, and then press VOL+ to select it.

Front Panel Jacks

You can use the front panel jacks to connect an A/V component that is used only occasionally, such as a camcorder or video game. (For information on connecting equipment, see pages 2.1 – 2.7.)

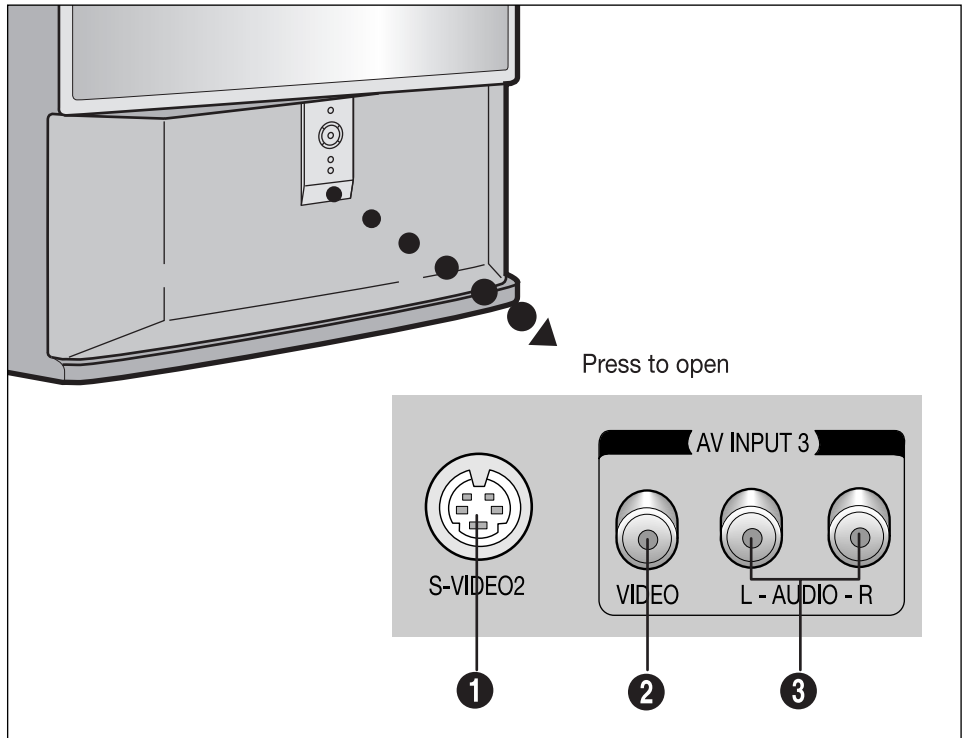

1 SUPER VIDEO IN jack
Used to connect an S-Video signal from a camcorder or a video game.

2 VIDEO IN jack
Used to connect a video signal from a camcorder or a video game.

3 AUDIO IN jacks
Used to connect the audio signals from a camcorder or video game.

Rear Panel Jacks

Use the rear panel jacks to connect an A/V component that will be connected continuously, such as a VCR or a laserdisc player.

Because there are two sets of input jacks, you can connect two different A/V components (i.e., a VCR and a laserdisc, 2 VCRs, etc.)

For more information on connecting equipment, see pages 2.1 – 2.7.

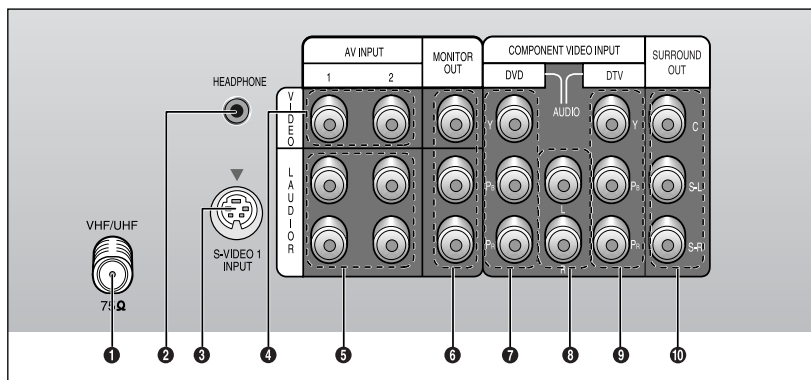

1 VHF/UHF

Connect to an antenna or to a cable TV system.

2 WIRELESS HEADPHONES

Connect a pair of wireless headphones here (optional)

3 SUPER VIDEO IN

S-Video signal from an S-VHS VCR or laserdisc player.

4 VIDEO INPUTS

Video signals from VCRs, laserdisc players and similar devices (Two sets are available: Video1 and Video2).

5 AUDIO INPUTS

Audio signals from VCRs, laserdisc players and similar devices.

6 AUDIO-VIDEO MONITOR OUTPUTS

These audio-video signals are identical to A/V signals being displayed on the big screen. (Typically used as the input signals for a recording VCR.)

Note: The monitor out does not operate in DVD or DTV mode.

7 DVD INPUT

Connect video from a DVD player.

8 DVD & DTV AUDIO INPUT

Connect to the audio output jacks of a DVD player & SET-TOP BOX.

9 DTV INPUT

(For models PCJ532RF/PCJ534RF/PCJ611RF/PCJ614RF/PCK5315R/PCK6115R)
Connects video from a SET-TOP BOX.

10 SURROUND OUT

Connects to the (optional) rear-surround amp: Surround Left, Surround Right and Center. Here are two ways to connect an audio amplifier:

1. TV - amp - speaker
2. TV - speaker(amp built-in).

Remote Control

You can use the remote control up to about 23 feet from the TV. When using the remote, always point it directly at the TV.

You can also use your remote control to operate your VCR and cable box. See page 4.1 for details.

- 1 POWER**
Turns the TV on and off.
- 2 ADD/ERASE**
Press to add or erase channels in the TV's memory.
- 3 PIP**
Activates picture in picture.
- 4 DISPLAY**
Press to display the current channel and the audio-video settings.
- 5 Number buttons**
Press to select channels directly on the TV.
- 6 +100**
Press to select channels over 100. For example, to select channel 121, press "+100," then press "2" and "1."
- 7 P.MODE**
Adjust the TV picture by selecting one of the preset factory settings (or select your personal, customized picture settings).
- 8 S.MODE**
Adjust the TV sound by selecting one of the preset factory settings (or select your personal, customized sound settings).
- 9 MUTE**
Press to temporarily cut off the sound.
- 10 CH▲ and CH▼ (Channel Up/Down)**
Press CH▲ or CH▼ to change channels. (Also used to highlight selections on the on-screen menus.)

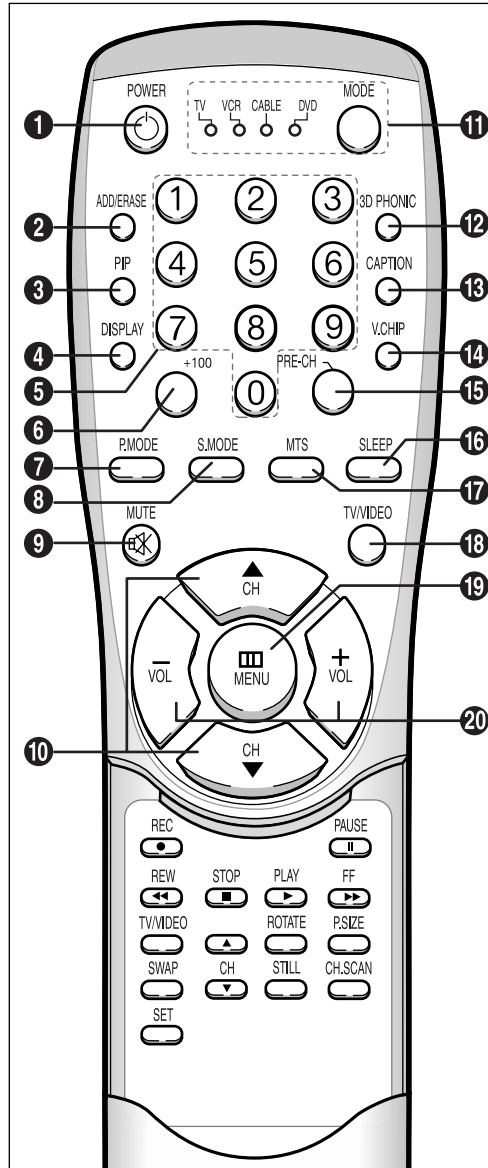

- 11 MODE**
Selects a target device to be controlled by the Samsung remote control (i.e., TV, VCR, Cable box, or DVD).
- 12 3D PHONIC**
Selects one of the 3D Phonic modes (Drama, Action or Theater).
- 13 CAPTION**
Controls the caption decoder.
- 14 V.CHIP**
Press to set up and activate the parental locks.
- 15 PRE-CH**
Tunes to the previous channel.
- 16 SLEEP**
Press to select a preset time interval for automatic shutoff.
- 17 MTS (Multichannel Television Stereo)**
Press to choose stereo, mono or Separate Audio Program (SAP broadcast).
- 18 TV/VIDEO**
Press to display all of the available video sources (i.e., Antenna/cable, VCR, DVD, Video1~3 and S-Video 1~2).
- 19 MENU**
Displays the main on-screen menu.
- 20 VOL -, VOL +**
Press increase or decrease the volume. (Also used to make selections on the on-screen menus.)

(For model PCJ533RF)

Remote Control (continued)

21 VCR controls

REC

Press to begin recording. (Note: A VCR must be connected.)

PAUSE

Press to pause the tape.

REW (Rewind)

Press to rewind a tape

STOP

Press to stop a tape in your VCR.

PLAY

Press to play the tape

FF (Fast Forward)

Press to fast forward a tape

22 SET

Used during set up of this Samsung remote control, so that it will work compatibly with other devices (VCR, cable box, etc.)

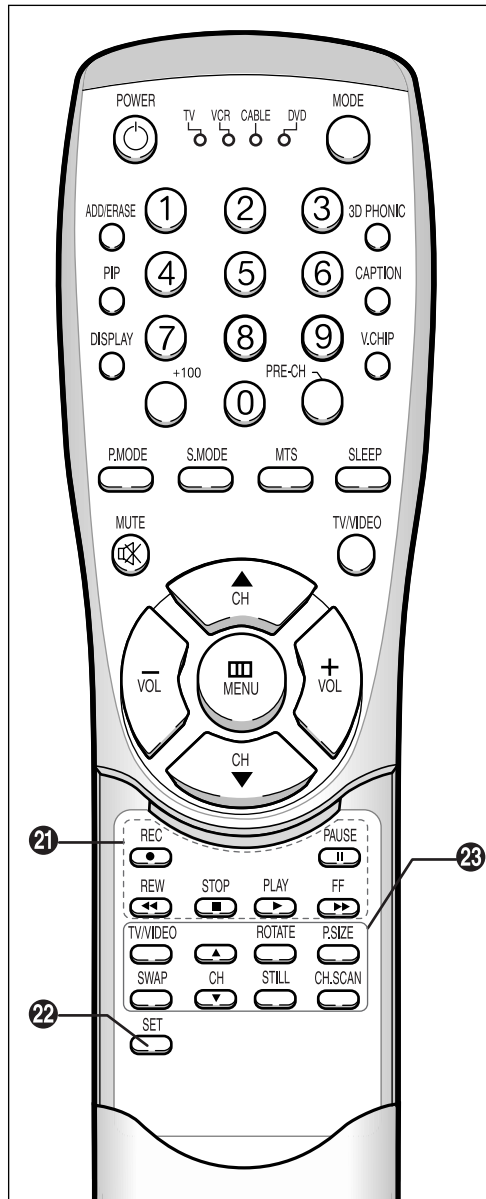

(For model PCJ533RF)

23 PIP Controls

TV/VIDEO

Press to select one of the available signal sources for the PIP window.

ROTATE

Press to move the PIP window to any of the four corners of the TV screen.

P.SIZE

Press to make the PIP window larger or smaller.

SWAP

Exchanges the video signal that is currently displayed on the main screen with the signal in the PIP window.

PIP CH

Displays the available channels in sequence. (These buttons change channels in the PIP window only).

STILL

Press to stop the action during a particular scene. Press again to resume normal video.

CH.SCAN

Press to memorize (scan) the available channels.

Remote Control (continued)

1 DTV

Press to activate a Digital TV Set-Top Box. (When the DTV mode is active, all channel selections must be made using a separate remote control that is supplied with the set-top box.)

When pressing the DTV button, the DTV mode is selected after approximately 5 seconds.

Select either 1080i or 480p format for the set-top box output signal. (Otherwise, the picture may flicker.)

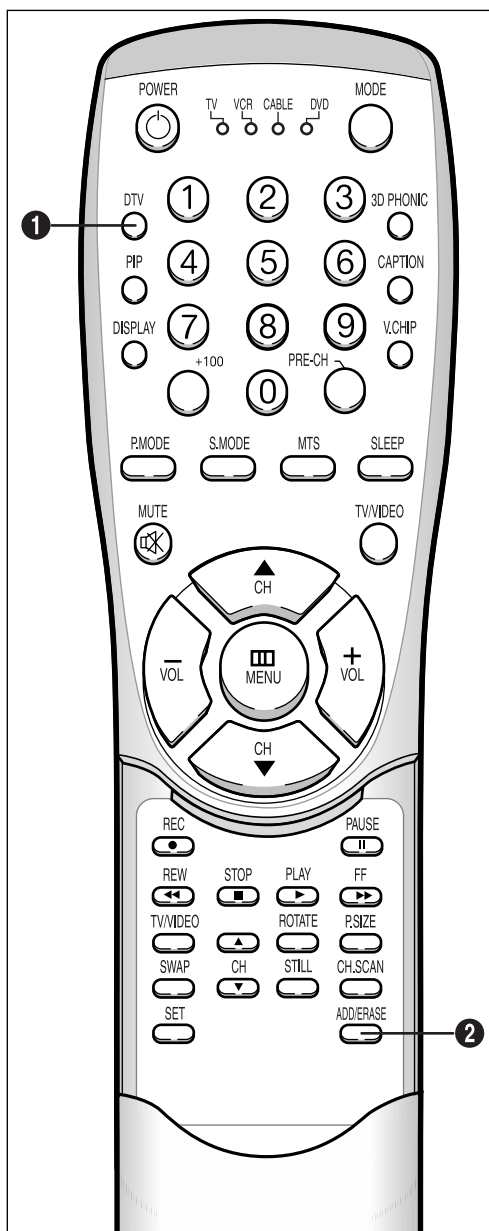

2 ADD/ERASE

Press to add or erase channels in the TV's memory.

(For model PCJ532RF/PCJ534RF/
PCJ611RF/PCJ614RF/PCK5315R/
PCK6115R)

Chapter Two

INSTALLATION

Connecting VHF and UHF Antennas

If your antenna has a set of leads that look like this, see “Antennas with 300-ohm Flat Twin Leads,” below.



If your antenna has one lead that looks like this, see “Antennas with 75-ohm Round Leads,” on page 2.2.

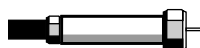

If you have two antennas, see “Separate VHF and UHF Antennas,” on page 2.2.

Antennas with 300-ohm Flat Twin Leads

If you are using an off-air antenna (such as a roof antenna or “rabbit ears”) that has 300-ohm twin flat leads, follow the directions below.

1

Place the wires from the twin leads under the screws on the 300-75 ohm adaptor (not supplied). Use a screwdriver to tighten the screws.

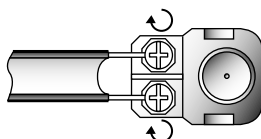

2

Plug the adaptor into the VHF/UHF terminal on the bottom of the back panel.

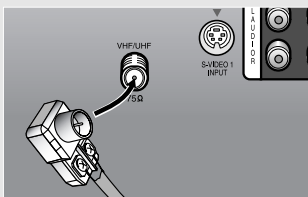

Antennas with 75-ohm Round Leads

- 1 Plug the antenna lead into the VHF/UHF terminal on the bottom of the back panel.

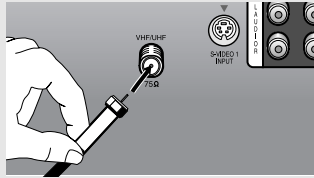

Separate VHF and UHF Antennas

If you have two separate antennas for your TV (one VHF and one UHF), you must combine the two antenna signals before connecting the antennas to the TV. This procedure requires a an optional combiner-adaptor (available at most electronics shops).

- 1 Connect both antenna leads to the combiner.

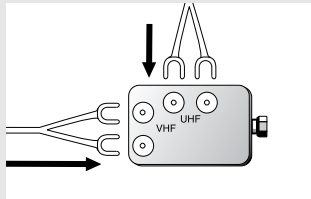

- 2 Plug the combiner into the VHF/UHF terminal on the bottom of the rear panel.

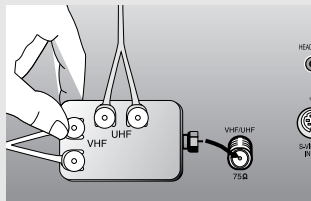

Connecting Cable TV

To connect to a cable TV system, follow the instructions below.

Cable without a Cable Box

- 1 Plug the incoming cable into the VHF/UHF antenna terminal on back of the TV.

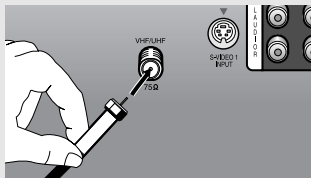

◀ Because this TV is cable-ready, you do not need a cable box to view unscrambled cable channels.

INSTALLATION

Connecting to a Cable Box that Descrambles All Channels

1
Find the cable that is connected to the ANTENNA OUT terminal on your cable box.

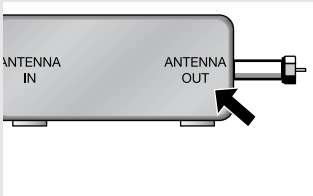

◀ This terminal might be labeled “ANT OUT,” “VHF OUT,” or simply, “OUT.”

2
Connect the other end of this cable to the VHF/UHF antenna terminal on the back of the TV.

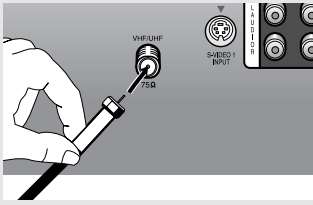

Connecting to a Cable Box that Descrambles Some Channels

If your cable box descrambles only some channels (such as premium channels), follow the instructions below. You will need a two-way splitter, an RF (A/B) switch, and four lengths of coaxial cable. (These items are available at most electronics stores.)

1
Find and disconnect the cable that is connected to the ANTENNA IN terminal on your cable box.

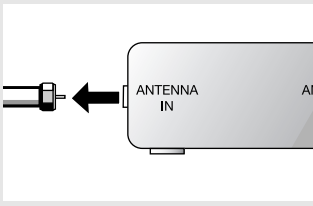

◀ This terminal might be labeled “ANT IN,” “VHF IN,” or simply, “IN.”

2
Connect this cable to a two-way splitter.

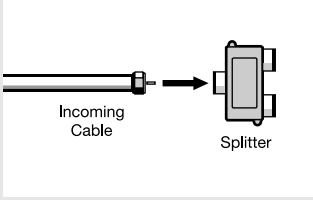

3
Connect a coaxial cable between an OUTPUT terminal on the splitter and the IN terminal on the cable box.

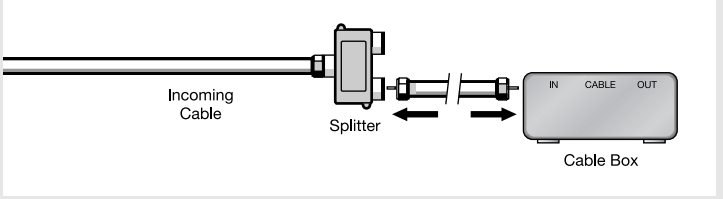

4

Connect a coaxial cable between the ANTENNA OUT terminal on the cable box and the B-IN terminal on the A/B switch.

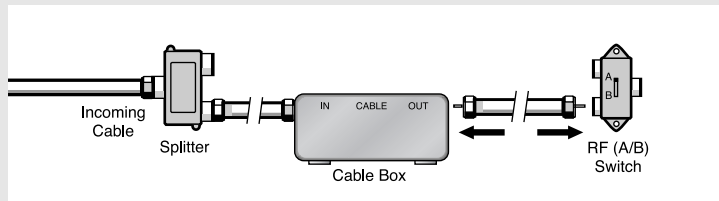

5

Connect another cable between the other OUT terminal on the splitter and the A-IN terminal on the RF (A/B) switch.

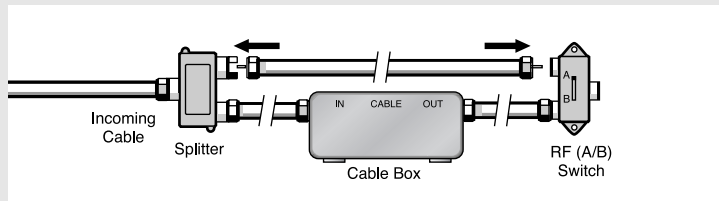

6

Connect the last coaxial cable between the OUT terminal on the RF (A/B) switch and the VHF/UHF terminal on the rear of the TV.

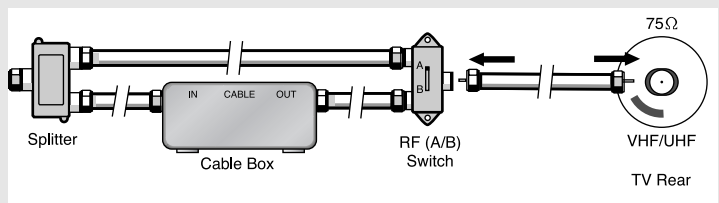

After you've made this connection, set the A/B switch to the "A" position for normal viewing. Set the A/B switch to the "B" position to view scrambled channels. (When you set the A/B switch to "B," you will need to tune your TV to the cable box's output channel, which is usually channel 3 or 4.)

Connecting a VCR

These instructions assume that you have already connected your TV to an antenna or a cable TV system (according to the instructions on pages 2.1-2.3). Skip step 1 if you have not yet connected to an antenna or a cable system.

1

Unplug the cable or antenna from the back of the TV.

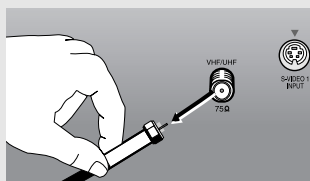

2

Connect the cable or antenna to the ANTENNA IN terminal on the back of the VCR.

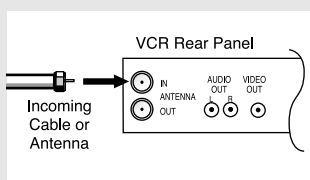

3

Connect a coaxial cable between the ANTENNA OUT terminal on the VCR and the antenna terminal on the TV.

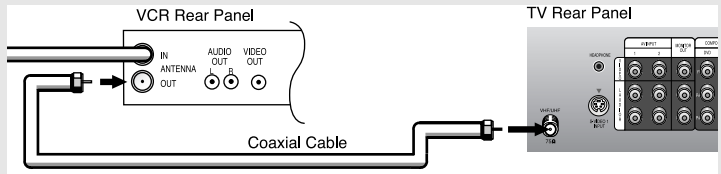

A coaxial cable is usually included with a VCR. (If not, check your local electronics store).

4

Connect a set of audio cables between the AUDIO OUT jacks on the VCR and the AUDIO jacks on the TV.

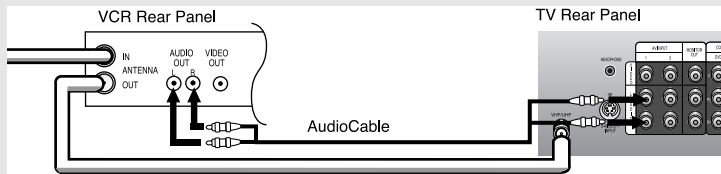

If you have a “mono” (non-stereo) VCR, use the Y-connector (supplied) to hook up to the left and right audio input jacks of the TV. If your VCR is stereo, you must connect two cables.

5

Connect a video cable between the VIDEO OUT jack on the VCR and the VIDEO jack on the TV.

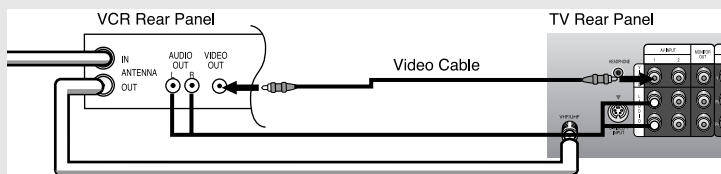

Follow the instructions in “Viewing a VCR or Camcorder Tape” to view your VCR tape.

Connecting an S-VHS VCR

Your Samsung TV can be connected to an S-Video signal from an S-VHS VCR. (This connection delivers a better picture as compared to a standard VHS VCR.)

1

To begin, follow steps 1–3 in the previous section to connect the antenna or cable to your VCR and your TV.

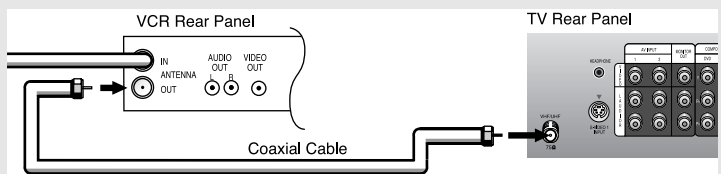

2

Connect a set of audio cables between the AUDIO OUT jacks on the VCR and the 2 AUDIO INPUT jacks on the TV.

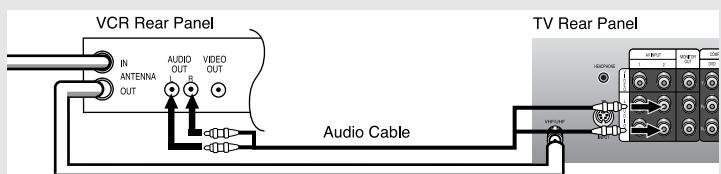

Make sure the jacks you are using are underneath the number “2.”

3

Connect an S-video cable between the S-VIDEO OUT jack on the VCR and the S-VIDEO INPUT jack on the TV.

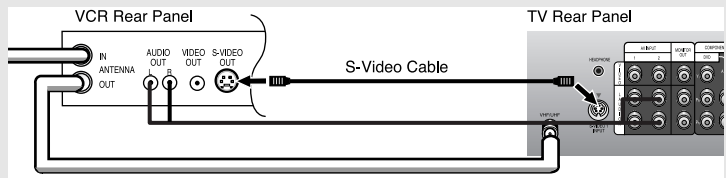

An S-video cable is usually included with an S-VHS VCR. (If not, check your local electronics store.)

Connecting a Second VCR to Record from the TV

Your TV can send out signals of its picture and sound to be recorded by a second VCR. To do this, connect your second VCR as follows:

1

Connect a set of audio cables between the AUDIO OUT jacks on the TV and the AUDIO IN jacks on the VCR.



(The VCR input jacks might be either on the front or on back of the VCR.)

2

Connect a video cable between the VIDEO OUT jack on the TV and the VIDEO IN jack on the VCR.

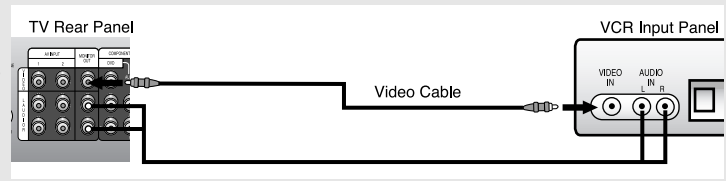

Refer to your VCR's instructions for more information about how to record using this kind of connection.

Connecting a Digital TV Set-Top Box

(For models PCJ532RF/PCJ534RF/PCJ611RF/PCJ614RF/PCK5315R/PCK6115R)

Connect the Y, Pb, and Pr video outputs of the set-top box to their corresponding inputs on the TV. Next, connect the Left and Right audio from the set-top box to the corresponding L and R terminals on the TV. (The connections for a typical set-top box are shown below.)

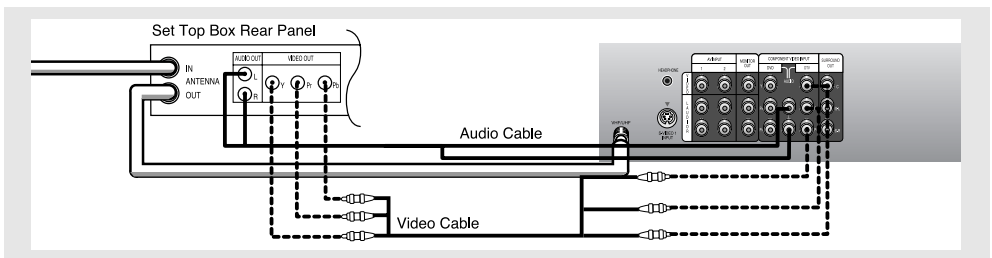

When switching to the DTV mode, either 480p or 1080i format is automatically selected according to the input signal.

Note: Only 480p and 1080i formats are supported in their original formats.

Connecting a Camcorder

The front panel jacks on your TV make it easy to connect a camcorder to your TV. They allow you to view the camcorder tapes without using a VCR. (Also see “Viewing a VCR or Camcorder Tape” on page 3.14)

1

Locate the A/V output jacks on the camcorder. They are usually found on the side or back of the camcorder.

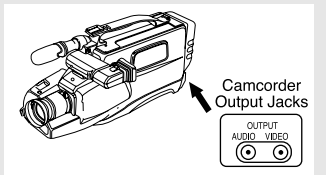

2

Connect an audio cable between the AUDIO OUTPUT jack on the camcorder and the AUDIO terminals on the front of the TV.

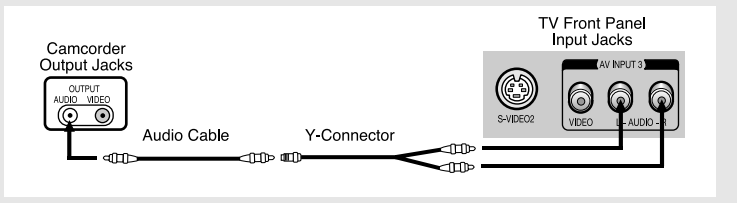

3

Connect a video cable between the VIDEO OUTPUT jack on the camcorder and the VIDEO terminal on the front of the TV.

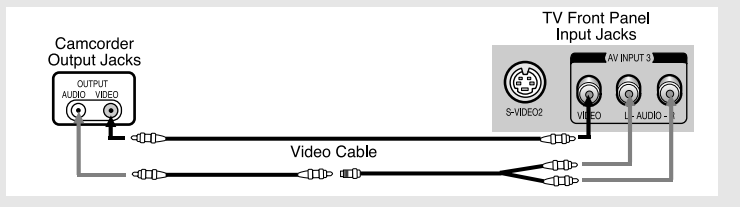

The audio-video cables shown here are usually included with a Camcorder. (If not, check your local electronics store.) If your camcorder is stereo, you need to connect a set of two cables.

Installing Batteries in the Remote Control

- 1**
Slide the cover out completely.

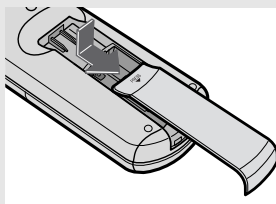

- 2**
Install two AAA size batteries.

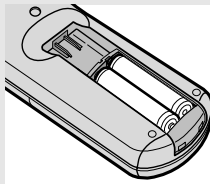

◀ Make sure to match the “+” and “-” ends of the batteries with the diagram inside the compartment.

- 3**
Replace the cover.

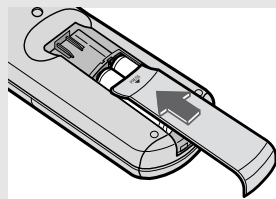

◀ Remove the batteries and store them in a cool, dry place if you won't be using the remote control for a long time.

The remote control can be used up to about 23 feet from the TV.

(Assuming typical TV usage, the Batteries last for about one year.)

Chapter Three

OPERATION

Turning the TV On and Off

Press **POWER**.

You can also use the POWER button on the front panel.

Adjusting Basic Convergence

If the color appears spread out or “smeared” on the screen, the convergence probably needs alignment. Be sure to use the remote control for the convergence adjustments. (The Convergence Adjustment cannot be made by using the control buttons on the front panel.)

First steps:

1

Press **MENU**.

Press **CH ▼** twice to highlight the Setup icon (starts blinking).

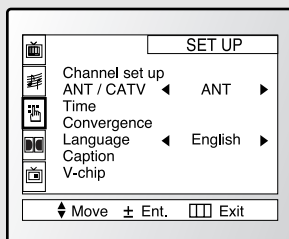

2

Press **VOL +**.
Press **CH ▼** three times to highlight “Convergence” (the letters change to blue color).

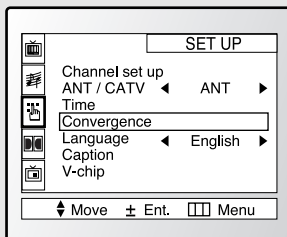

3

Press **VOL +**: The “Manual Convergence” screen will appear, and the word “Red” will be highlighted.

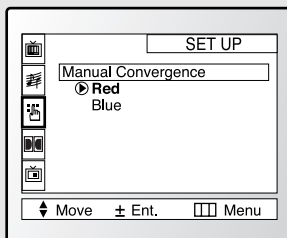

continued...

Adjust Red Convergence

4

While "Red" is highlighted (letters are blue color), press the **VOL+** button: A crosshair pattern will appear on the screen. If either a vertical or a horizontal red line is visible, then the convergence needs alignment.

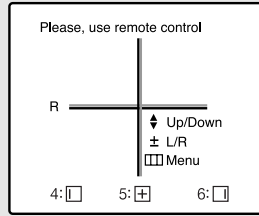

5

If a horizontal red line is visible, use **CH▲** and **CH▼** buttons to move the line so that it is superimposed on the horizontal center-line (i.e., make a single horizontal line that is as white as possible.)

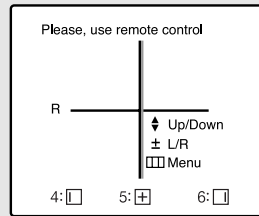

6

If a vertical red line is visible, use the **VOL +** and **VOL -** buttons to move the line so that it is superimposed on vertical-center line (i.e., make a single vertical line that is as white as possible.)

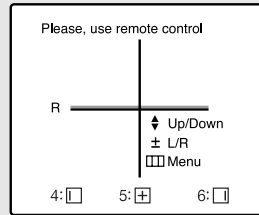

To do Left or Right Convergence

7

If the left adjustments need, press the number(4) button on the remote control to move the vertical red line to the left. Use the **VOL +/-** buttons to move the line to the right or left.

If the right adjustments need, press the number(6) button on the remote control to move the vertical red line to the right. Use the **VOL +/-** buttons to move the line to the right or left.

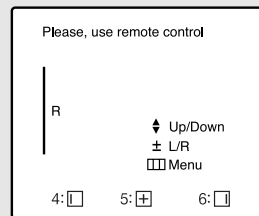

8

After the red convergence is correctly adjusted, press **MENU** four times to exit all the menus.

◀ Note: While the left and right adjustments are done, the **CH▲** and **CH▼** buttons will not work.

•For 'Blue' adjustment, do the same as the above.

Viewing the Menus and On-Screen Displays

Viewing the Menus

1

With the power on, press **MENU**.

The main menu appears on the screen. Its left side has five icons: Video, Audio, Setup, Dolby and PIP.

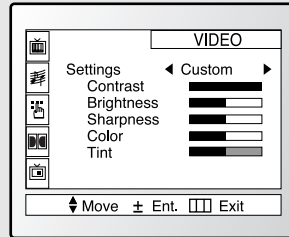

◀ The on-screen menu disappears from the screen after about thirty seconds.

2

Use the **CH▲** and **CH▼** buttons to highlight one of the 5 icons (the icons blink when highlighted). Then press **VOL+** to access the icon's sub-menu.

3

Press **MENU** to exit.

◀ You can also use the **MENU**, **CHANNEL**, and **VOLUME** buttons on the control panel of the TV to make selections.

Viewing the Display

The display identifies the current channel and the status of certain audio-video settings.

1

Press the **DISPLAY** on the remote control.

The TV will display the channel, the type of audio, and the status of certain video and audio settings.

("MFT" indicates a channel has been manually fine tuned.)

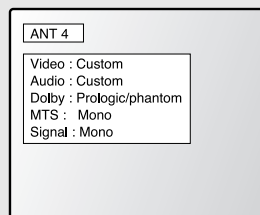

◀ The on-screen displays disappear after about ten seconds.

Selecting a Menu Language

1

Press **MENU** to display the menu.

Press **CH ▼** two times to select "SET UP."

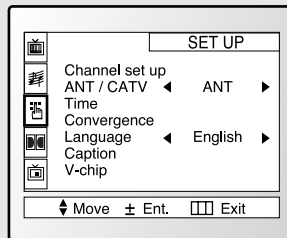

2

Press **VOL +** to display the "SET UP" menu.

Press **CH ▼** four times to highlight Language.

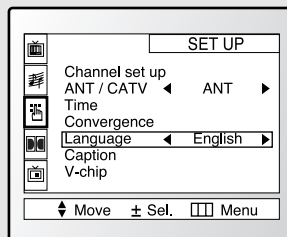

3

Press **VOL +** to select the appropriate language: English, Spanish, or French.

Note: Language is selected depending on model (English and Spanish or English and French).

4

Press **MENU** twice to exit.

Memorizing the Channels

Your TV can memorize and store all of the available channels for both “off-air” (antenna) and cable channels. After the available channels are memorized, use the CH ▲ and CH ▼ buttons to scan through the channels. This eliminates the need to change channels by entering the channel digits. There are three steps for memorizing channels: selecting a broadcast source, memorizing the channels (automatic) and adding and deleting channels (manual).

Selecting the Video Signal-source

Before your television can begin memorizing the available channels, you must specify the type of signal source that is connected to the TV (i.e., an antenna or a cable system).

1

Press **MENU** to display the menu.

2

Press **CH ▼** two times to highlight “SET UP.”

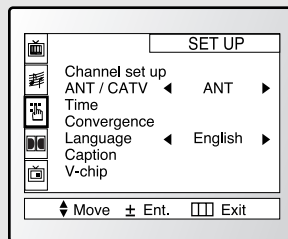

3

Press **VOL +**. The setup sub-menu will appear. Press **CH ▼** to highlight ANT/CATV.

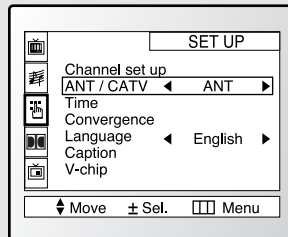

4

Repeatedly press **VOL +** to cycle through these choices:
ANT (antenna)
STD, HRC or IRC (all cable TV).

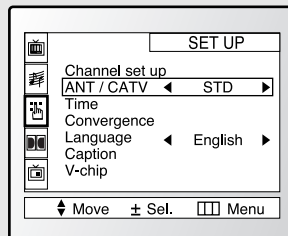

Note: STD, HRC and IRC identify various types of cable TV systems. Contact your local cable company to identify the type of cable system that exists in your particular area.

At this point the signal source has been selected. Proceed to “Storing Channels in Memory” (next page).

Storing Channels in Memory (Automatic Method)

1

First, select the correct signal source (ANT, STD, HRC, IRC). See steps 1-4 on previous page.

Press **MENU**, then press **CH ▼** twice to highlight "SET UP."

Press **VOL +** to access the SETUP sub-menu. "Channel set up" will be highlighted.

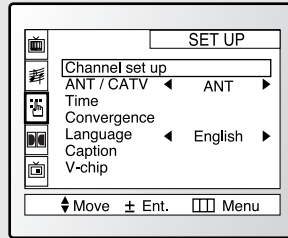

2

Press **VOL +** while "Channel set up" is highlighted. A new sub-menu will appear, and "Auto program" will be highlighted.

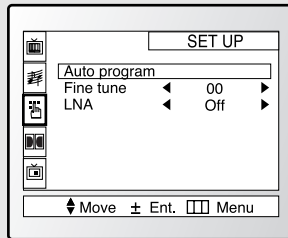

3

Press **VOL +** again. The TV will begin memorizing all of the available channels.

4

After all the available channels are stored, the Auto program menu reappears. Press Menu three times to exit.

Note: Channel auto program does not function when the V-chip is active.

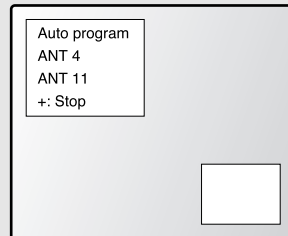

◀ The TV automatically cycles through all of the available channels and stores them in memory. This takes about one to two minutes.

Press **VOL+** at any time to interrupt the memorization process and return to the Setup menu.

Adding and Erasing Channels (Manual Method)

1

Use the number buttons to directly select the channel that will be added or erased.

2

Press **ADD/ERASE**:
Repeatedly pressing this button will alternate between "Channel added" and "Channel erased."

Press **MENU** to exit.

You can view any channel (including an erased channel) by using the number buttons on the remote control.

Changing Channels

Using the Channel Buttons

1

Press the **CH ▲** or **CH ▼** button to change channels.

When you press **CH ▲** or **CH ▼**, the TV changes channels in sequence. You will see all the channels that the TV has memorized. (The TV must have memorized at least three channels.) You will not see channels that were either erased or not memorized.

Directly Accessing Channels

Use the number buttons to quickly tune to any channel.

1

Press the number buttons to go directly to a channel. For example, to select channel 27, press "2," then "7." The TV will change channels when you press the second number.

When you use the number buttons, you can directly select channels that were either erased or not memorized.

To select a channel over 100, press the **+100** button. (For channel 122, press "+100," then "2," then "2.")

To change to single-digit channels (0–9) faster, press "0" before the single digit. (For channel "4," press "0," then "4.")

Setting the Clock

1

Press the **MENU** button to display the on-screen menu.

2

Press **CH ▼** twice to highlight "SET UP." Press **VOL +**.

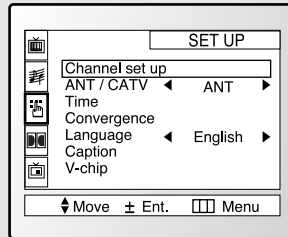

3

Press **CH ▼** twice to highlight Time menu.

Press **VOL +**: The Time menu will appear on the screen, and "Clock" will be highlighted (blue color).

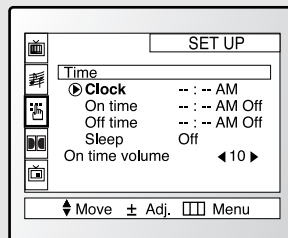

4

Press **VOL +** again (the hours digits will start blinking). Press **CH ▼** repeatedly until the correct hour appears.

After the hour is entered, press **VOL +** (at this point the minutes digits will start blinking).

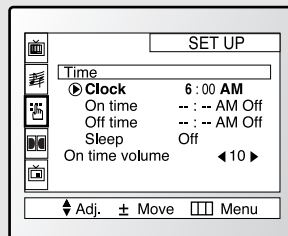

5

Press the **CH ▲** or **CH ▼** button to select the correct minutes.

After selecting the correct minutes, press **VOL +**.

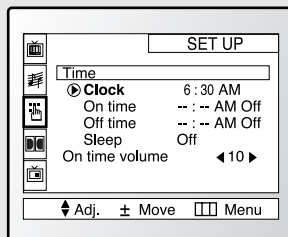

6

Press **MENU** three times to exit.

◀ When selecting the hours, be sure to select the proper time of day (AM or PM).

You can change the hours by pressing **CH ▲** or **CH ▼** repeatedly (or by holding down either of these buttons).

◀ The time will appear every time you press DISPLAY.

Adjusting the Volume

1

Press **VOL +** or **-VOL** to increase or decrease the volume.

Using Mute

At any time, you can temporarily cut off the sound using the Mute button.

1

Press **MUTE** and the sound cuts off.

The word "Mute" will appear in the lower-left corner of the screen.

2

To turn mute off, press **MUTE** again, or simply press either the **VOL -** or **VOL +** button.

Customizing the Picture

You can use the on-screen menus to change the contrast, brightness, tint, color, and sharpness according to personal preference. (Alternatively, you can use one of the “automatic” settings. See next page.)

1

Press **MENU** to access the main menu.

The VIDEO icon will be highlighted (starts blinking).

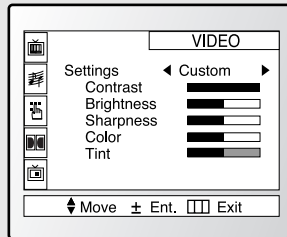

2

Press **VOL -** or **VOL +** repeatedly, until the word “Custom” is highlighted. (When Custom is highlighted, the words “Contrast,” “Brightness,” “Sharpness,” “Color,” and “Tint” will appear on the screen.)

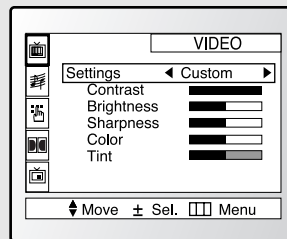

3

Press **CH ▼** or **CH ▲** button to highlight a particular item.

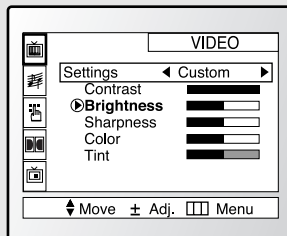

4

Press **VOL -** or **VOL +** to increase or decrease the value of a particular item. For example, if you select “Brightness,” pressing **VOL +** increases it.

Press **MENU** twice to exit.

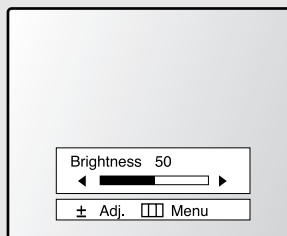

◀ After adjusting an item, the gauge will automatically disappear (after about 5 seconds).

Using Automatic Picture Settings

Your Samsung TV has two automatic picture settings (“Standard” and “Mild”) that are preset at the factory. You can activate either Standard or Mild by pressing PMode (or by making a selection from the menu). Or, you can select “Custom” which automatically recalls your personalized picture settings.

1

Press **MENU** to display the menu. Video icon will be highlighted (blinking).

Press **VOL +** to display the VIDEO menu.

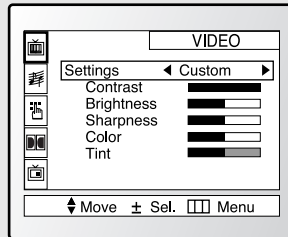

2

Press **VOL -** or **VOL +** to select the “Standard,” “Mild,” or “Custom” picture setting.

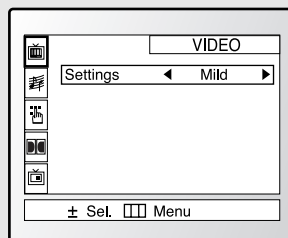

3

Alternate method:

Simply press the **P.MODE** button on the remote control to select one of the standard picture settings.

- Choose *Standard* for the standard factory settings.
- Choose *Mild* (“Mild Contrast”) when viewing the TV in low light, or when playing video games.
- Choose *Custom* if you want to adjust the settings according to personal preference (see “Customizing the Picture, page 3.10).

Customizing the Sound

You can use the on-screen menus to adjust the bass, treble, and balance according to individual preference. (Alternatively, you can use one of the “automatic” settings. See next page.)

1

Press **MENU** to display the menu.

Press **CH ▼** to highlight the **AUDIO** icon (starts blinking).

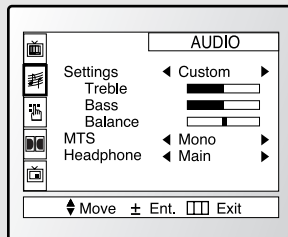

2

Press **VOL -** or **VOL +** repeatedly, until the word “Custom” is highlighted. (When Custom is highlighted, the words “Bass,” “Treble,” and “Balance” will appear on the screen.)

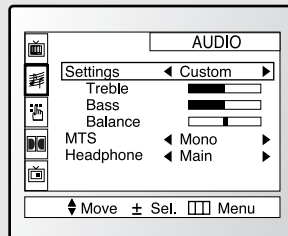

3

Press the **CH ▲** or **CH ▼** buttons to highlight a particular item to be changed.

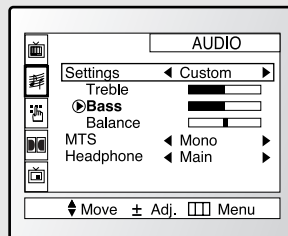

4

Press **VOL -** or **VOL +** to increase or decrease the value of a particular item. For example, if you select “Bass,” pressing **VOL +** increases it.

Press **MENU** twice to exit.

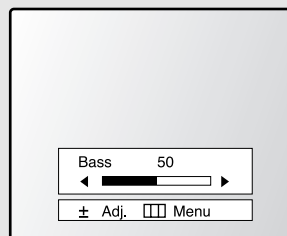

◀ When you are finished adjusting an item, wait about 10 seconds. The gauge will disappear and the Audio menu will return.

Using Automatic Sound Settings

Your TV has four automatic sound settings (“Standard,” “Music,” “Speech,” and “Movie”) that are preset at the factory. You can activate any of them by pressing the S.MODE button (or by making a selection from the on-screen menu). Or, you can select “Custom,” which automatically recalls your personalized sound settings.

1

Press **MENU** to display the menu.

Press **CH▼** once to highlight the **AUDIO** menu.

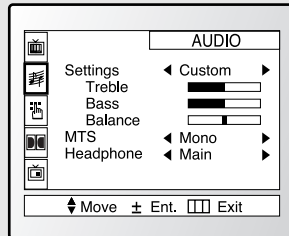

2

Press **VOL -** or **VOL +** repeatedly to select the “Standard,” “Music,” “Speech,” “Movie” or “Custom” audio settings.

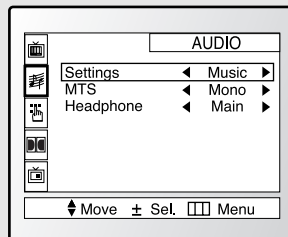

3

Alternate method:

Simply press the **S.MODE** button on the remote control to select one of the standard sound settings.

- Choose *Standard* for the standard factory settings.
- Choose *Music* when watching music videos or concerts.
- Choose *Speech* when watching a show that is mostly dialogue (i.e., news).
- Choose *Movies* when watching movies.
- Choose *Custom* to recall your personalized settings.

Viewing a VCR or Camcorder Tape

You must select the appropriate mode in order to view the VCR or Camcorder signal on the TV.

1

Make sure that the remote control is controlling the TV set. (Press the **MODE** button and make sure that the "TV" LED is illuminated.)

2

Press **TV/VIDEO** on the remote control, and the following on-screen menu will appear:

TV/Video Menu

ANT/CATV
Video1
Video2
Video3
S-Video1
S-Video2
DVD

3

Use the **CH▲** or **CH▼** button to highlight a particular signal source, and then press **VOL+** to activate it.

Press **TV/VIDEO** to exit.

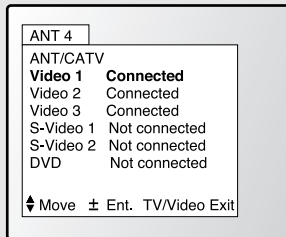

When you press the TV/Video button, the on-screen display identifies all the active video sources (and their corresponding input jacks):

Select	Video jack	Audio jack
Video 1	Video 1 (rear panel)	Audio 1 "L+R"
Video 2	Video 2 (rear panel)	Audio 2 "L+R"
Video 3	Video 3 (front panel)	Audio 3 "L+R"
S-Video 1	S-Video 1 (rear panel)	Audio 2 "L+R"
S-Video 2	S-Video 2 (front panel)	Audio 3 "L+R"
DVD	DVD-rear	DVD Audio "L+R"

Chapter Four

SPECIAL FEATURES

Customizing Your Remote Control

Your Samsung TV comes equipped with a “universal” remote control. In addition to controlling the TV, the universal remote can also operate a VCR, DVD and a cable box (even if your VCR and cable box are made by manufacturers other than Samsung).

Setting Up Your Remote Control to Operate Your VCR

1

Turn off your VCR or DVD.

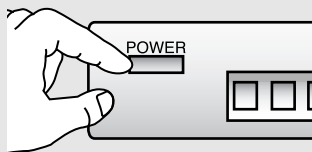

2

Press the **MODE** button and make sure that the **VCR** LED is illuminated.

◀ The remote control has four “modes”: “TV,” “VCR,” “CABLE” and “DVD.” Press the “MODE” button to switch the remote control to the “VCR” mode.

3

On your Samsung remote control, press **SET**.

4

Enter 3 digits of the VCR code listed on the next page for your brand of VCR.

◀ Make sure you enter 3 digits of the code, even if the first digit is a “0.”

If more than one code listed, try the first one.

5

Press **POWER** on the remote control. Your VCR should turn on. If your VCR turns on, your remote control is now set correctly.

◀ If your VCR does not turn on, repeat steps 2, 3, and 4, but try one of the other codes listed for the brand of your particular VCR.

If no other codes are listed, try each code, 000 through 089.

6

Once your remote control is set up, press the **MODE** button any time you want to use the remote to operate your VCR.

◀ When your remote control is in the “VCR” mode, the volume buttons still control your TV’s volume.

When your remote is in the “TV” mode, the VCR control buttons (PLAY, PAUSE, etc.) will still operate your VCR.

✓ Set the DVD mode in the same methods as above.

SPECIAL FEATURES

VCR Codes

Admiral	006, 079	KLH	073	RCA	000, 005, 007, 008, 028, 035, 037, 054, 069
Aiwa	015	LG	009, 014, 046, 060	Samsung	007, 013, 022, 032, 042, 077
Akai	017, 022, 023, 027, 030	Lloyd	015	Sansui	016
Audio Dynamics	014, 016	Logik	031	Sanyo	002, 012
Bell & Howell	002	LXI	015	Scott	013, 041, 049, 068
Broksonic	010	Magnavox	008, 029, 053, 056	Sears	002, 005, 009, 012, 018, 019, 035, 043, 048
Candle	007, 009, 013, 045, 046, 052	Marantz	002, 008, 014, 016, 029, 030, 046, 061	Sharp	006, 027, 039, 045
Cannon	008, 053	Marta	009	Shintom	017, 026, 031, 055
Citizen	007, 009, 013, 045, 046, 052	MEI	008	Signature	015
Colortyme	014	Memorex	008, 009, 012, 015	Sony	017, 026, 038
Craig	007, 012	MGA	027	Sylvania	008, 015, 029, 053, 056
Curtis-Mathes	000, 007, 008, 014, 015, 046, 053, 064, 067	Midland	032	Symphonic	015
Daewoo	013, 045, 076	Minota	005, 035	Tandy	002, 015
DBX	014, 016	Mitsubishi	005, 027, 035, 040	Tashiko	009
Dimensia	000	Montgomery ward	006	Tatung	030
Dynatech	015	MTC	007, 015	Teac	015, 030, 069
Electrohome	027	Multitech	007, 015, 031, 032	Technics	008
Emerson	008, 009, 010, 013, 015, 020, 023, 027, 034, 041, 042, 047, 049, 057, 062, 065, 067, 068, 070	NEC	002, 014, 016, 030, 046, 061, 064	Ternika	008, 009, 015, 021
Fisher	002, 012, 018, 019, 043, 048, 058	Optimus	006	TMK	067
Funai	015	Panasonic	008, 053, 075, 077	Toshiba	005, 013, 019, 048, 049
GE	000, 007, 008, 032, 053	Pentax	005, 035	Totevision	007, 009
Go Video	007	Pentex Reserch+	046	Unitech	007
Harman Kardon	014	Philco	008, 029, 053, 056	Vector Research	014, 016
Hitachi	005, 015, 035, 036	Philips	008, 029	Victor	016
Instant Replay	008	Pioneer	005, 016, 033, 050	Video Concepts	014, 016
JC Penney	002, 005, 007, 008, 014, 016, 030, 035, 051, 053	Portland	044, 045, 052	Videosonic	007
JCL	008, 002, 014, 016, 030, 046	ProScan	000	Wards	005, 006, 007, 008, 009, 012, 013, 015, 027, 031, 035
JVC	002, 014, 088, 089	Quartz	002	Yamaha	002, 014, 016, 030, 046
Kenwood	002, 014, 016, 030, 046	Quasar	008, 053	Zenith	011, 017, 026, 079
		Radio Shack/Realist	002, 006, 008, 009, 012, 015, 019, 027, 045, 053		

DVD Codes

Philips	001
Proscan	002
RCA	002
Toshiba	003
Panasonic	004
Sony	008
Samsung	000

Setting Up Your Remote Control to Operate Your Cable Box

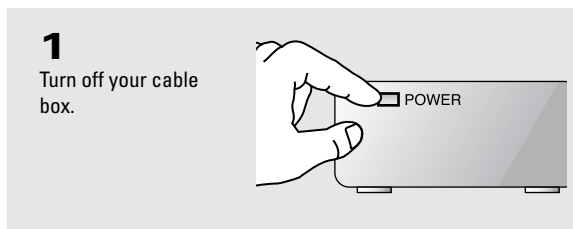

continued...

SPECIAL FEATURES

2

Press the **MODE** button and make sure that the **CABLE LED** is illuminated.

◀ The remote control has four “modes”: “TV,” “VCR,” “CABLE” and “DVD.”

Press the “MODE” button to switch the remote control to the “Cable” mode.

3

On your Samsung remote control, press **SET**.

4

Enter 3 digits of the cable box code listed below for your brand of cable box.

◀ Make sure you enter 3 digits of the code, even if the first digit is a “0.” (If more than one code listed, try the first one.)

5

Press **POWER**. Your cable box should turn on. If your cable box turns on, your remote control is now “set up” correctly.

◀ If your cable box does not turn on, repeat steps 2, 3, and 4, but try one of the other codes listed for your particular brand of cable box. (If no other codes are listed, try each cable box code, 000 through 077.)

6

Once your remote control is set up, press the **MODE** button any time you want to use the remote to operate your cable box.

◀ When your remote control is in the “CABLE” mode, the volume buttons still control your TV’s volume. Also, the VCR control buttons (PLAY, PAUSE, etc.) will still operate your VCR.

Cable Box Codes

Anvision	007, 008	NSC	009	Signature	046
Cablestar	007, 008	Oak	016, 038	Sprucer	027
Eagle	007, 008	Osk Sigma	016	Starcom	046
Eastern Int.	002	Panasonic	003, 027, 039, 061, 073, 074	Stargate 2000	058
General Instrument	046	Philips	007, 008, 019, 021, 026, 028, 029, 032, 033, 040, 041	Sylvania	011, 059
GI	004, 005, 015, 023, 024, 025, 030, 036, 067, 068, 069	Pioneer	018, 020, 044, 074, 077	Texscan	011, 059
Hamlin	003, 012, 013, 034, 048	Randtek	007, 008	Tocom	017, 021, 049, 050, 055, 073
Hitachi	037, 043, 046	RCA	000, 027, 066	Unika	031, 032, 041
Jerroid	004, 005, 015, 023, 024, 025, 030, 036, 046, 062, 065	Regal	003, 012, 013	Universal	051, 052
Macom	037, 043	Regency	002, 033	Viewster	007, 008, 019, 021, 026, 028, 029, 032, 033, 040, 041
Magnavox	007, 008, 019, 021, 026, 028, 029, 032, 033, 040, 041	SA	070, 071, 072	Warner Amex	044
		Samsung	044, 003, 022, 063, 064	Zenith	014, 042, 057, 061, 075, 076

Setting the On/Off Timer

1

Press **MENU** to display the menu.

Press **CH ▼** twice to highlight the "SET UP" sub-menu.

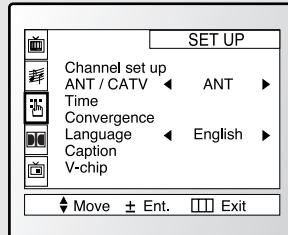

◀ Before using the timer, you must set the TV's clock. (See "Setting the Clock" on page 3.8)

When any of the timers are set, the "Timer" LED will illuminate (front panel of TV).

2

Press **VOL +** to select the "SET UP" sub-menu.

Press **CH ▼** twice to highlight "Time."

Press **VOL +**

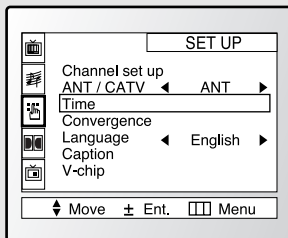

3

Press **CH ▼** to select "On time."

Press **VOL +** to highlight the "On time" hours. (The hours digits will start blinking.)

Press **CH ▲** or **CH ▼** repeatedly to select the appropriate hours (i.e., the hour when the TV will turn on.)

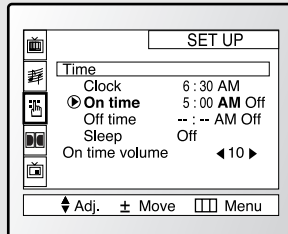

◀ When you set the hours, make sure the correct time of day (AM or PM) appears to the left of the hour.

4

Press **VOL +** to highlight the "On time" minutes. (The minutes digits will start blinking.)

Press **CH ▲** or **CH ▼** to select the appropriate minutes.

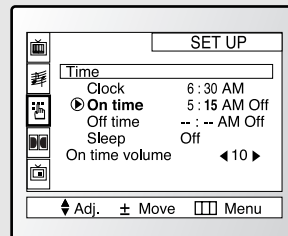

continued...

5

Press **VOL +** to highlight "On/Off."

Press **CH ▲** (or **CH ▼**) to turn the on-timer "On." (Repeatedly pressing **CH ▲** or **CH ▼** will alternate between on and off.)

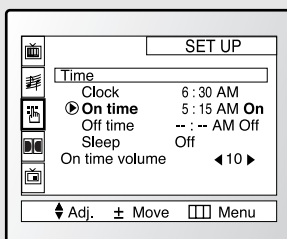

◀ To deactivate the "On time," select "Off" during this step.

6

When finished, press **VOL +**.

7

To set the Off time, press **CH ▼** to highlight "Off time."

Press **VOL +** and set the hours and minutes. (Follow the same procedure as in steps 1~6 above.)

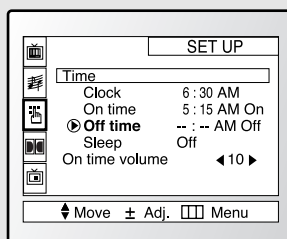

8

When finished setting the timer, press **MENU** three times to exit.

Setting the Sleep Timer

The sleep timer automatically shuts off the TV after a preset time (from 10 to 360 minutes).

1

Press the **SLEEP** button on the remote control.

2

Press **SLEEP** repeatedly until the appropriate time interval appears (any of the preset values from "Off" to "360").

◀ After about 5 seconds, the sleep display will disappear from the screen, and the time interval will be set.

Viewing Closed Captions

Your TV decodes and displays the closed captions that are broadcast with certain TV shows. These captions are usually subtitles for the hearing impaired or foreign-language translations. All VCRs record the closed caption signal from television programs, so home-recorded video tapes also provide closed captions. Most pre-recorded commercial video tapes provide closed captions as well. Check for the closed caption symbol in your television schedule and on the tape's packaging: .

Note: The Caption feature does not work with DVD or DTV signals.

The DTV mode is not available on model PCJ533RF.

1

Press **MENU** to display the menu.

Press **CH** \blacktriangledown two times to select the "SET UP" menu.

Press **VOL+**.

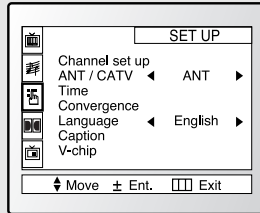

◀ Quick way to access captions menu: Simply press the Caption button on the remote control:

2

Press **CH** \blacktriangledown five times to select the "Caption" menu.

Press **VOL+** to open the Caption menu.

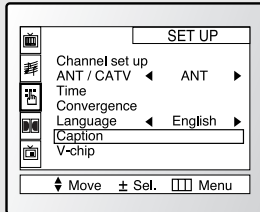

3

Press **VOL+** or **VOL-** to turn closed captioning on/off.

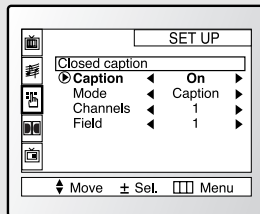

◀ Misspellings and unusual characters sometimes occur during closed caption transmissions, especially those of live events. There may be a small delay before captions appear when you change channels. These are not malfunctions of the TV.

4

Press **CH** \blacktriangledown to highlight "Mode."

Press **VOL-** or **VOL+** to select "Caption" or "Text."

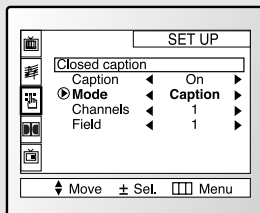

◀ In **caption mode**, captions appear at the bottom of the screen, and they usually cover only a small portion of the picture.

In **text mode**, information unrelated to the program, such as news or weather, is displayed. Text often covers a large portion of the screen.

5

Depending on the particular broadcast, it might be necessary to make changes to "Channels" and "Field":

Use the **CH** \blacktriangle , **CH** \blacktriangledown , **VOL+** and **VOL-** buttons to make the changes. (Follow the same procedure as in steps 3-4 above.) Press **MENU** three times to exit.

◀ Different channels and fields display different information: Field 2 carries additional information that supplements the information in Field 1. (For example, Channel 1 may have subtitles in English, while Channel 2 has subtitles in Spanish.)

Fine Tuning Channels

Use fine tuning to manually adjust a particular channel for optimal reception.

1
Select the appropriate channel.

2
Press **MENU**.
Press **CH ▼** two times to highlight "SET UP."

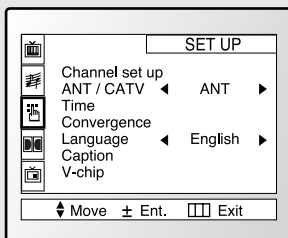

3
Press **VOL +** to select Setup menu. (Channel set up" will be highlighted.)

Press **VOL +** so that "Auto program" is highlighted.

Press **CH ▼** once to select "Fine tune."

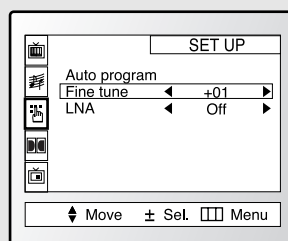

4
Press the **VOL -** and **VOL +** buttons to adjust the fine tuning.

◀ After you adjust the fine tuning, the letters "MFT" will appear when you press DISPLAY while watching this channel.

5
To store the fine tuning setting in the TV's memory, press **CH ▲**. (A yellow-heart icon will appear.)

To reset the fine tuning to "00," press **CH ▼**.

◀ Press the MENU button to resume normal viewing.

LNA (Low Noise Amplifier)

If the TV is operating in a weak-signal area, sometimes the LNA function can improve the reception (a low-noise preamplifier boosts the incoming signal).

1

Press **MENU** to display the menu.

Press **CH** ▼ two times to highlight the "SET UP" menu.

Press **VOL +** to select the Set up menu. "Channel set up" will be highlighted.

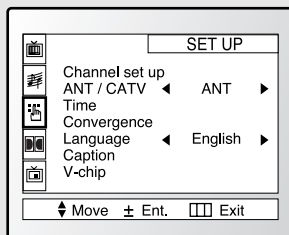

2

Press **VOL +** to select "Channel set up."

Press **CH** ▼ twice to highlight "LNA."

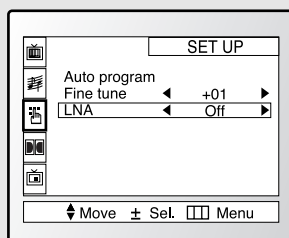

3

Press **VOL -** or **VOL +** to select LNA "on."

Press **MENU** three times to exit.

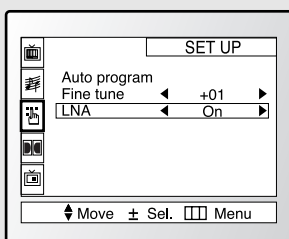

◀ Pressing **VOL -** or **VOL +** will alternate between "On" and "Off."

Special Audio Options: Dolby Surround, MTS, and Headphones

Depending on the particular type of audio that is being broadcast, you can listen to any of three modes: Mono, Stereo and SAP (Secondary Audio Programming, which is typically a foreign-language translation).

The Dolby Surround options (3D-Phonic and Dolby Prologic) simulate the ambience of a stadium or a movie theater. The wireless headphone option is especially useful when simultaneously watching the main screen and the PIP window.

Dolby Prologic

Your Samsung TV can create a “surround” effect such that the sound seems to come from all directions.

1

Press **MENU**, then press the **CH▼** button three times. The **DOLBY SURROUND** icon will be highlighted (starts blinking).

Press **VOL +** as often as necessary to select the appropriate surround system (“Off”, “Prologic,” or “3D Phonic”).

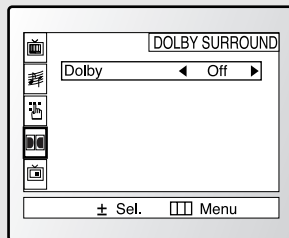

2

If Dolby Prologic is selected, follow the instructions below. For “3D Phonic,” see next page.

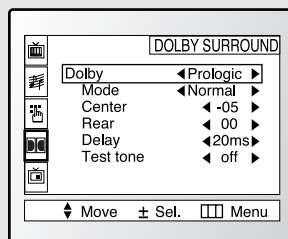

Select the mode: Press the **CH▼** button to highlight “Mode.” Next, press **VOL+** repeatedly until the appropriate mode appears (“Wide,” “Phantom,” or “Normal”). Some recommended settings:

- Phantom : Selected when the center speaker is either not present or not used.
In Phantom Mode, the center sound is output through both left and right speakers.
- Normal : Selected when the center speaker is smaller than the main TV speakers. In Normal Mode, the sound of the center channel is output through both left and right speakers.
- Wide : Selected when the center speaker is larger than the TV speaker. In Wide Mode, the sound of center channel is output through only the center speaker.

After selecting the mode, press the **CH▼** button, and highlight “Center.” Next, press **VOL+** or **VOL-** and, depending on personal preference, select any value between -10 and +10. Follow a similar procedure for “Rear” and “Delay.” (Some trial-and-error experimenting is necessary to find the optimal setting, which will vary according to individual preference).

After entering values for “Center,” “Rear,” and “Delay,” use the **CH▼** and **VOL+** buttons to activate “Test.” During “Test,” a tone will cycle through the speakers so you can hear the surround effect and make additional changes as needed.

Press **MENU** twice to exit.

Dolby 3D Phonic

3

Follow steps one and two (previous page). Select 3D Phonic. Then press **VOL +** to select one of these three modes:

“Drama,”
“Action,” or
“Theater”.

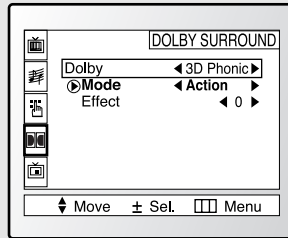

◀ Quick way to access the 3D-Phonic menu: Just press “3D-PHONIC” on the remote control:

Next, press the **CH▼** button so that “Effect” is highlighted (the letters turn blue). Repeatedly press either **VOL+** or **VOL-** to set the effect. (The actual setting depends on personal preference: Select any value between -5 and +5.)

4

Press **MENU** twice to exit.

Manufactured under license from Dolby Laboratories Licensing Corporation.

DOLBY, the double-D symbol  and “PRO LOGIC” are trademarks of Dolby Laboratories Licensing Corporation.

Notes

In order to enjoy the Dolby sound in the Dolby Pro Logic Mode, connect the TV to the external center and surround speakers. The external speakers are not provided. They must be purchased separately.

The Dolby surround properly functions only when software such as Video tape having the double-D symbol “” is played.

When viewing software not recorded using Dolby sound or an ordinary TV program set the Dolby mode to “Off”.

Choosing a Multi-Channel Sound (MTS) Soundtrack

Depending on the particular program being broadcast, you can listen to stereo, mono, or a Separate Audio Program. (SAP audio is usually a foreign-language translation. Sometimes SAP has unrelated information like news or weather.)

1

Press **MENU** to display the menu.

Press **CH▼** once to highlight the AUDIO menu.

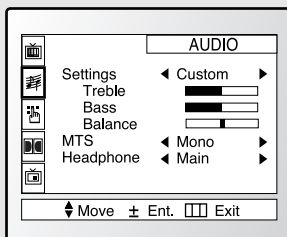

Quick way to access the MTS menu: Just press "MTS" on the remote control:

2

Press **VOL +** to select the AUDIO menu.

Press **CH▼** to highlight "MTS".

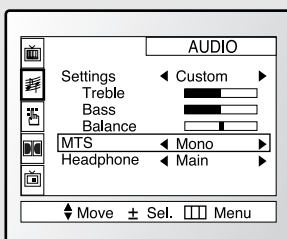

3

Press **VOL +** repeatedly to select "Mono," "SAP," or "Stereo."

Press **MENU** twice to exit

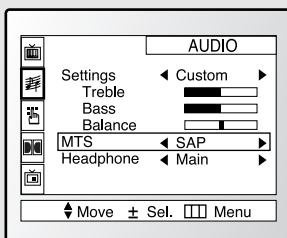

◀ The text at the bottom of the menu tells you if the incoming audio is stereo, SAP, or mono.

- Choose *Stereo* for channels that are broadcasting in stereo.
- Choose *Mono* for channels that are broadcasting in mono, or if you are having difficulty receiving a stereo signal.
- Choose *SAP* to listen to the Separate Audio Program, which is usually a foreign-language translation.

You can also change the MTS setting by pressing the "MTS" button on the remote control. (When you change channels, MTS is set to "Stereo" automatically. To listen in 'SAP' or 'Mono,' change the MTS setting.)

Using Wireless Headphones

1

Connect the transmitter cable to the Wireless Headphone jack on the bottom of the back panel.

2

Turn the transmitter and Wireless Headphones on.

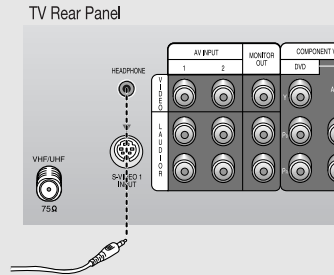

◀ Note: Wireless headphones must be purchased separately.

3

Adjust the volume of the Wireless Headphones.

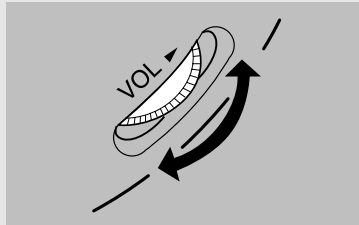

Setting up Wireless Headphones with Picture-in-Picture

(See page 4.13 for information about the various options for picture-in-picture.)

1

Press **MENU** and press **CH ▼** once to highlight the AUDIO icon.

Press **VOL+**, then press **CH ▼** to highlight "Headphone."

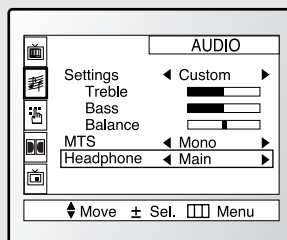

◀ Note: The "Headphone" option is active only when the PIP window is active.

2

Press **VOL+** to alternate between "Main" and "Sub" (the sound associated with program in PIP window). If PIP is not active, then the "Sub" option is not available.

Press **MENU** twice to exit.

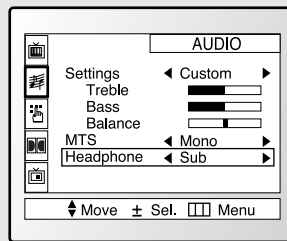

◀ Notes: If there is an obstacle between the transmitter and the Wireless Headphones, the sound may be affected. For additional details, see your Wireless Headphones instruction book.

Viewing Picture-in-Picture

You can use the PIP feature to simultaneously to watch two video sources.
 Note: The PIP feature does not work with DVD or DTV signals.

The DTV mode is not available on model PCJ533RF.

Activating Picture-in-Picture

1

Press **MENU** to display the menu.

Press **CH▼** four times to highlight the PIP menu.

Press **VOL +** to select the PIP menu.

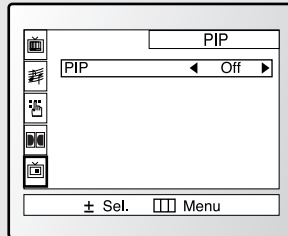

◀ Quick way to access the PIP menu: Simply press the PIP button on the remote control:

2

Press **VOL +** to select PIP "On."

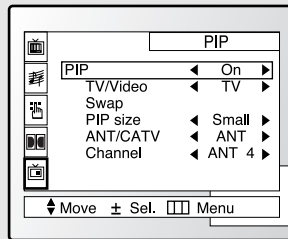

◀ If you turn TV off while watching and turn it on again, the PIP window will disappear.

3

Press **MENU** twice to exit.

Note: Picture-in-Picture does not function when the V-chip is active.

Selecting a Signal Source (Antenna or Cable) for PIP

1

Press **MENU** to display the menu.

Press **CH▼** four times to select the PIP menu.

Press **VOL +** to select the PIP menu.

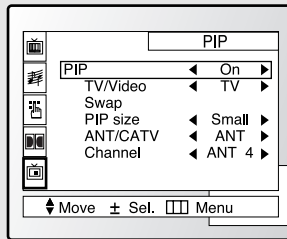

2

Press **CH▼** four times to select "ANT/CATV."

If an antenna is connected, the setting is "ANT."

If a Cable TV system is providing the signal, press **VOL +** or **VOL -** until the appropriate type of cable system is displayed ("STD," "HRC," or "IRC").

Press **MENU** twice to exit.

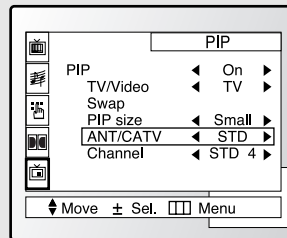

Selecting a Signal Source (External A/V) for PIP

Press **TV/VIDEO** repeatedly to cycle through all of the available signal sources: "TV," "Video 1," "Video 2," "Video 3," "S-Video 1," and "S-Video 2."

◀ For more information about external A/V components and signals, see "Viewing a VCR or Camcorder Tape" on page 3.14.

If you select "TV", the PIP image is the same as the main image.

Swapping the Contents of the PIP image and Main image

When you press the **SWAP** button:
The image in the PIP window will appear on the main screen, and vice versa.

Changing the PIP Channel

Press PIP **CH▲** or **CH▼** to change the channel that appears in the PIP window

Changing the Location (Rotating) the PIP Window

When you press the **ROTATE** button repeatedly, the PIP window moves from corner to corner on the TV screen.

Freezing the PIP Image

Press **STILL** to stop the action in a particular scene. Press **STILL** again to resume normal video.

Changing the Size of the PIP Window

Press **P.SIZE** to alternate between a smaller and larger PIP window.

Scanning the Available Channels

This procedure scans all of the available channels and then stores them in memory.

Press **CH.SCAN**, and the memorized channels will appear in sequence for 2 to 3 seconds per channel.
Press **CH.SCAN** again to stop the scanning process.

When CH.SCAN stops, the viewing mode will return to its original setting.

Using the V-Chip

The V-Chip feature automatically locks out programming that is deemed inappropriate for children. The user must first enter a PIN (personal ID number) before any of the V-Chip restrictions can be set up or changed.

Note : When the V-chip feature is active, the PIP and channel-auto program features do not function.

Setting Up Your Personal ID Number (PIN)

1

Press **MENU** to display the menu.

Press **CH ▼** two times to select the "SET UP" menu.

Press **VOL +**.

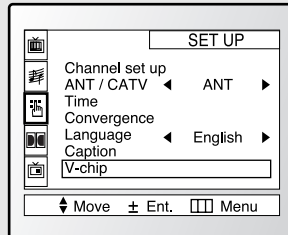

Quick way to access the V-Chip menu: Simply press the V.CHIP button on the remote control:

2

Press **CH ▼** six times to select the "V-chip" menu.

Press **VOL+**.

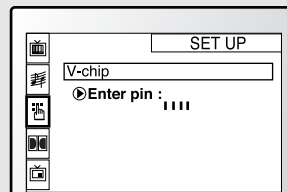

The "Enter pin" screen will appear. Enter your 4-digit PIN number. Note: The default PIN number for a new TV set is "0-0-0-0."

3

After entering a valid PIN number, the "V-chip mode" screen will appear. Press **CH ▼** three times and highlight "Change pin."

(Note: When a particular field is highlighted, its color turns BLUE.)

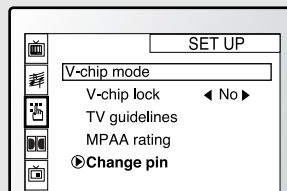

4

While the "Change pin" field is selected, press **VOL+**. The Change pin screen will appear. Choose any 4-digits for your PIN and enter them.

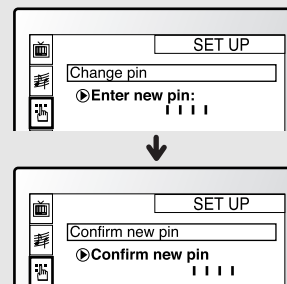

As soon as the 4 digits are entered, the "Confirm pin" screen appears. Re-enter the same 4 digits. When the Confirm screen disappears, your PIN has been memorized. Press **MENU** to exit.

◀ Note: If you forget the PIN, press the remote-control keys in the following sequence, which resets the pin to 0-0-0-0:

POWER OFF → MUTE → 8 → 2 → 4 → POWER ON.

How to Enable/Disable the V-Chip

1
Press **MENU**.

Press **CH ▼** two times to select the "SET UP" menu.

Press **VOL +**.

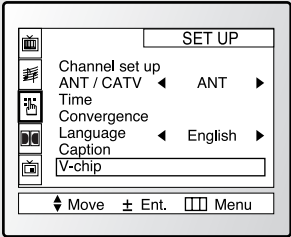

2
Press **CH ▼** six times to highlight the "V-chip" menu.

Press **VOL +**.

The "Enter pin" screen will appear. Enter your 4-digit PIN number.

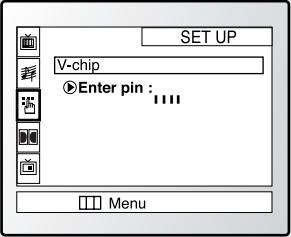

3
The "V-Chip mode" screen will appear, and "V-Chip lock" will be highlighted (turns blue color).

To enable the V-Chip feature, press **VOL +** so that the "V-Chip lock" field is YES. (Pressing **VOL +** will alternate between YES and NO.)

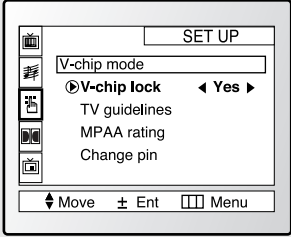

How to Set up Restrictions Using the "TV guidelines"

First, set up a personal identification number (PIN), and enable the V-Chip. (See previous section.) Parental restrictions can be set up using either of two methods: The TV guidelines or the MPAA rating.

1
Press **MENU** to display the menu.

Press **CH ▼** two times to highlight the "SET UP" menu.

Press **VOL +**.

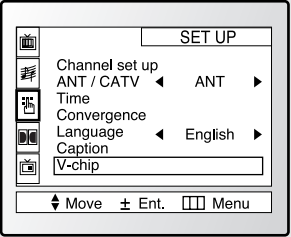

2

Press **CH ▼** six times to highlight the “V-chip” menu.

Press **VOL+** .

The “Enter pin” screen will appear. Enter your 4-digit PIN number.

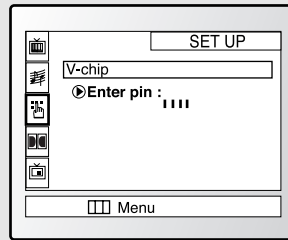

3

The “V-chip mode” screen will appear. Press the **CH ▼** button, and highlight the field for “TV Guidelines.” (Note: When a particular field is highlighted, its color turns BLUE.)

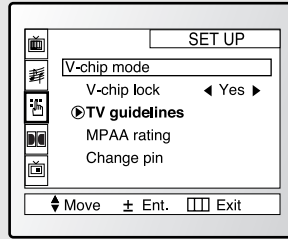

4

Press **VOL+**. The “TV guidelines” screen will appear. Press the **CH ▲**, **CH ▼** buttons to highlight one of the six age-based categories:

TV-Y	Young children
TV-Y7	Children 7 and over

TV-G	General audience
TV-PG	Parental guidance
TV-14	Viewers 14 and over
TV-MA	Mature audience

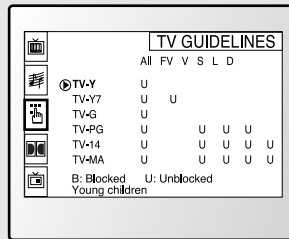

◀ Note: These categories consist of two separate groups: TV-Y and TV-Y7 (young children through age 7), and TV-G through TV-MA (everybody else). The TV-Y and TV-Y7 categories are colored green.

The restrictions for these two groups work independently: If a household includes very young children as well as young adults, the TV guidelines must be set up separately for each age group. (See next step.)

5

At this point, one of the TV-Ratings is highlighted (blue color).

Press the **VOL+** button: Depending on your existing setup, a letter “U” or “B” will start blinking. (U= Unblocked, B= Blocked)

While the “U” or “B” is blinking, press the **CH ▲** or **CH ▼** button to block or unblock the category.

Press MENU once to save the TV guidelines. A TV-Rating will be highlighted (BLUE), and no letters will blink. To exit this screen, press MENU again. To select a different TV-Rating, press **CH ▲** or **CH ▼** and then repeat the process.

Note 1: The TV-Y7, TV-PG, TV-14 and TV-MA have additional options. See the next step to change any of the following sub-ratings:

- FV: Fantasy violence
- D: Dialog
- L: L
- S: Sexual situation
- V: Violence

Note 2: The V-Chip will automatically block certain categories that are “more restrictive.” For example, if you block “TV-Y” category, then TV-Y7 will automatically be blocked. Similarly, if you block the TV-G category, then all the categories in the “young adult” group will be blocked (TV-G, TV-PG, TV-14 and TV-MA). The sub-ratings (D, L, S, V) work together similarly. (See next section.)

6

How to set the FV, D, L, S and V sub-ratings.

First, highlight one of these TV-Ratings: TV-Y7, TV-PG, TV-14 or TV-MA (See Step 4, on previous page).

Next, while the TV-Rating is highlighted (BLUE), repeatedly press the **VOL+** button. This will cycle through the available sub-ratings (FV, L, S, D or V).

A blinking letter ("U" or "B") will be displayed for each sub-rating. While the "U" or "B" is blinking, press **CH ▲** or **CH ▼** to change the sub-rating.

Press **MENU** once to save the TV guidelines. A TV-Rating will be highlighted (BLUE), and no letters will blink. To exit this screen, press **MENU** again. To select a different TV-Rating, press **CH ▲** or **CH ▼** and then repeat the process.

Note: The V-chip will automatically block certain categories that are "More restrictive". For example, if you block "L" sub-rating in TV-PG, then the "L" sub-ratings in TV-14 and TV-MA will automatically be blocked.

7

Press the **MENU** button three times to clear all the screens. (Or proceed to the next section, and set up additional restrictions based on the MPAA codes).

How to Set up Restrictions using the MPAA Ratings: G, PG, PG-13, R, NC-17, X

The MPAA rating system uses the Motion Picture Association of America (MPAA) system, and its main application is for movies. (Eventually, movie videocassettes will be encoded with MPAA ratings.) When the V-Chip lock is on, the TV will automatically block any programs that are coded with objectionable ratings (either MPAA or TV-Ratings).

1

Press **MENU** to display the menu.

Press **CH ▼** two times to highlight the "SET UP" menu.

Press **VOL +**.

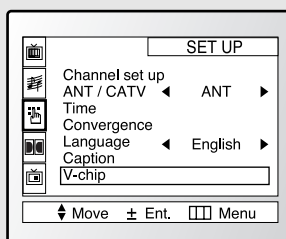

2

Press **CH ▼** six times to highlight the "V-chip" menu.

Press **VOL+**.

The "Enter pin" screen will appear. Enter your 4-digit PIN number.

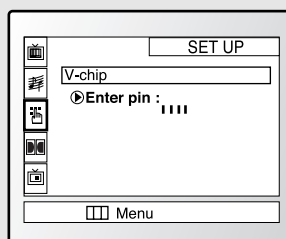

3

The "V-chip mode" screen will appear. Press the **CH ▼** button twice, and highlight "MPAA rating."

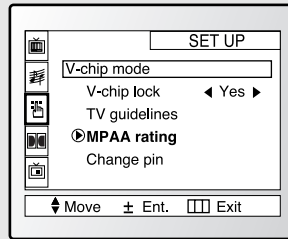

4

While "MPAA rating" is highlighted, press the **VOL+** button. The "MPAA rating" screen will appear.

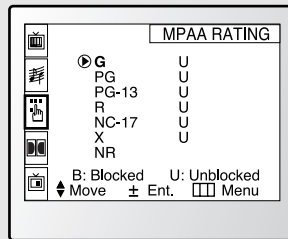

5

Repeatedly press the **CH ▼** button to highlight a particular MPAA category. (When a category is highlighted, its color changes to blue.) Pressing the **CH ▼** button will cycle through the MPAA categories:

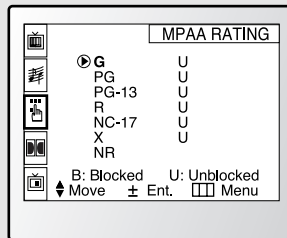

- G** General audience (no restrictions).
- PG** Parental guidance suggested.
- PG-13** PG-13 (Parents strongly cautioned).
- R** R (Restricted. Children under 17 should be accompanied by an adult).
- NC-17** No children under age 17.
- X** X (Adults only).
- NR** Not rated.

While a particular category is highlighted, press **VOL+** to activate it. A blinking letter ("U" or "B") will be displayed. Press **CH ▲** or **CH ▼** to select "U" or "B".

Press **MENU** three times to save the settings and to clear all screens.

Note: The V-Chip will automatically block any category that is "more restrictive." For example, if you block the "PG-13" category, then "R," "NC-17," and "X" will automatically be blocked also.

How to Reset the TV after the V-Chip Blocks a Channel ("Emergency Escape")

If the TV is tuned to a restricted channel, the V-Chip will block it. The screen will go blank and the following message will appear: "Excessive rating."

To resume normal viewing, tune to a different channel using the number buttons. Under certain conditions (depending on the rating of the local TV programs) the V-Chip might lock out all the channels. In this case, use the V-Chip button for an "emergency escape":

Press the V-chip button on the remote control. Enter your PIN number, and press **VOL+** to temporarily disable the V-Chip Lock.

Chapter Five

TROUBLESHOOTING

If the TV seems to have a problem, first try this list of possible problems and solutions. If none of these troubleshooting tips apply, then call your nearest service center.

Identifying Problems

Problem	Possible Solution
Poor picture	Try another channel. Adjust the antenna. Check all wire connections.
Poor sound quality.	Try another channel. Adjust the antenna.
No picture or sound.	Try another channel. Press the TV/VIDEO button. Make sure the TV is plugged in. Check the antenna connections.
No color, wrong colors or tints.	Make sure the program is broadcast in color. Adjust the picture settings.
Picture rolls vertically.	Adjust the antenna. Check all wire connections.
The TV operates eratically	Unplug the TV for 30 seconds, then try operating it again.
Your remote control does not operate your TV.	Press the "MODE" button to put your remote control in the "TV" mode.
The TV won't turn on.	Make sure the wall outlet is working.

Note: If you watch a still image or the screen in the 16:9 aspect ratio format for a long time, some burning images may be seen on the screen.

Cleaning and Maintaining Your TV

With proper care, your TV unit will give you many years of service. Please follow these guidelines to get the maximum performance from your TV.

Placement

- Do not place the TV near extremely hot, cold, humid or dusty places.
- Do not place the TV near appliances with electric motors that create magnetic fields, such as vacuum cleaners.
- Keep the ventilation openings clear; do not place the TV on a soft surface, such as cloth or paper.
- Place the TV in a vertical position only.

Liquids

- Do not handle liquids near or on the TV. Liquids that spill into it can cause serious damage.

Cabinet

- Never open the cabinet or touch the parts inside.
- Wipe your TV with a clean, dry cloth. Never use water, cleaning fluids, wax, or chemicals.
- Do not put heavy objects on top of the cabinet.

Temperature

- If your TV is suddenly moved from a cold to a warm place, unplug the power cord, and allow at least two hours for moisture that may have formed inside the unit to dry completely.

Using Your TV in Another Country

If you plan to take your TV with you to a foreign country, please be aware of the different television systems that are in use around the world. A TV designed for one system may not work properly with another system due to differences in the TV channel frequencies

Specifications

Model	PCJ532RF / PCJ533RF / PCJ534RF / PCJ611RF / PCJ614RF / PCK5315R / PCK6115R
Voltage	AC 120V
Frequency of Operation	60Hz
Power Consumption	285 Watts
Dimension	PCJ532RF / PCJ533RF : 1167 x 615 x 1418mm ; 45.94 x 24.21 x 55.83 inches PCJ534RF / PCK5315R : 1167 x 615 x 1418mm ; 45.94 x 24.21 x 55.83 inches PCJ611RF / PCJ614RF/PCK6115R: 1131 x 694 x 1524mm ; 44.53 x 27.32 x 60.00 inches
Weight	PCJ532RF / PCJ533RF / PCJ534RF / PCK5315R: 78 Kg; 171.96 lbs PCJ611RF / PCJ614RF / PCK6115R : 132 Kg; 291.01 lbs

Free Manuals Download Website

<http://myh66.com>

<http://usermanuals.us>

<http://www.somanuals.com>

<http://www.4manuals.cc>

<http://www.manual-lib.com>

<http://www.404manual.com>

<http://www.luxmanual.com>

<http://aubethermostatmanual.com>

Golf course search by state

<http://golfingnear.com>

Email search by domain

<http://emailbydomain.com>

Auto manuals search

<http://auto.somanuals.com>

TV manuals search

<http://tv.somanuals.com>