

– Mini ECO-i System Air Conditioner – for Refrigerant R410A

■ R410A Models Indoor Units

	Class	7	9	12	18	24	36	48
X	4-Way Air Discharge Semi-Concealed Type			XHX1252	XHX1852	XHX2452	XHX3652	
A	1-Way Air Discharge Semi-Concealed Type	AHX0752	AHX0952	AHX1252				
U	Concealed Duct Type	UHX0752		UHX1252	UHX1852	UHX2452	UHX3652	
D	Concealed Duct High-Static Pressure Type						DHX3652	DHX4852
T	Ceiling-Mounted Type			THX1252	THX1852	THX2452		
K	Wall-Mounted Type	KHX0752	KHX0952	KHX1252	KHX1852	KHX2452		

Outdoor Units

	Class	36	60
C	Mini ECO-i	CHX03652	CHX06052

* Refrigerant R410A is used in the outdoor units.

Optional Controllers

RC	Timer Wired Remote Controller	RCS-TM80BG
	Wireless Remote Controller (For U, D Type)	RCS-BH80AAB.WL
	Wireless Remote Controller (For X Type)	RCS-SH80AAB.WL
	Wireless Remote Controller (For A, T Type)	RCS-TRP80AAB.WL
	Wireless Remote Controller (For K Type)	RCS-SH1AAB
	Simplified Remote Controller	RCS-KR1AGB
	System Controller	SHA-KC64UG
	Intelligent Controller	SHA-KT256BA
	Communication Adaptor	SHA-KA128AAB
	Remote Sensor	ART-K45AGB
LonWorks Interface	SHA-LN16UAB	

IMPORTANT!

Please Read Before Starting

This air conditioning system meets strict safety and operating standards. As the installer or service person, it is an important part of your job to install or service the system so it operates safely and efficiently.

For safe installation and trouble-free operation, you must:

- Carefully read this instruction booklet before beginning.
- Follow each installation or repair step exactly as shown.
- Observe all local, state, and national electrical codes.
- This product is intended for professional use. Permission from the power supplier is required when installing an outdoor unit that is connected to a 16 A distribution network.
- Pay close attention to all warning and caution notices given in this manual.



WARNING

This symbol refers to a hazard or unsafe practice which can result in severe personal injury or death.



CAUTION

This symbol refers to a hazard or unsafe practice which can result in personal injury or product or property damage.

If Necessary, Get Help

These instructions are all you need for most installation sites and maintenance conditions. If you require help for a special problem, contact our sales/service outlet or your certified dealer for additional instructions.

In Case of Improper Installation

The manufacturer shall in no way be responsible for improper installation or maintenance service, including failure to follow the instructions in this document.

SPECIAL PRECAUTIONS

WARNING When Wiring



ELECTRICAL SHOCK CAN CAUSE SEVERE PERSONAL INJURY OR DEATH. ONLY A QUALIFIED, EXPERIENCED ELECTRICIAN SHOULD ATTEMPT TO WIRE THIS SYSTEM.

- Do not supply power to the unit until all wiring and tubing are completed or reconnected and checked.
- Highly dangerous electrical voltages are used in this system. Carefully refer to the wiring diagram and these instructions when wiring. Improper connections and inadequate grounding can cause **accidental injury or death**.
- **Ground the unit** following local electrical codes.
- Connect all wiring tightly. Loose wiring may cause overheating at connection points and a possible fire hazard.

When Transporting

Be careful when picking up and moving the indoor and outdoor units. Get a partner to help, and bend your knees when lifting to

reduce strain on your back. Sharp edges or thin aluminum fins on the air conditioner can cut your fingers.

When Installing...

...In a Room

Properly insulate any tubing run inside a room to prevent "sweating" that can cause dripping and water damage to walls and floors.

...In Moist or Uneven Locations

Use a raised concrete pad or concrete blocks to provide a solid, level foundation for the outdoor unit. This prevents water damage and abnormal vibration.

...In an Area with High Winds

Securely anchor the outdoor unit down with bolts and a metal frame. Provide a suitable air baffle.

...In a Snowy Area (for Heat Pump-type Systems)

Install the outdoor unit on a raised platform that is higher than drifting snow. Provide snow vents.

When Connecting Refrigerant Tubing

- Ventilate the room well, in the event that is refrigerant gas leaks during the installation. Be careful not to allow contact of the refrigerant gas with a flame as this will cause the generation of poisonous gas.
- Keep all tubing runs as short as possible.
- Use the flare method for connecting tubing.
- Apply refrigerant lubricant to the matching surfaces of the flare and union tubes before connecting them, then tighten the nut with a torque wrench for a leak-free connection.
- Check carefully for leaks before starting the test run.

When Servicing

- Turn the power OFF at the main power box (mains) before opening the unit to check or repair electrical parts and wiring.
- Keep your fingers and clothing away from any moving parts.
- Clean up the site after you finish, remembering to check that no metal scraps or bits of wiring have been left inside the unit being serviced.



CAUTION

- Ventilate any enclosed areas when installing or testing the refrigeration system. Escaped refrigerant gas, on contact with fire or heat, can produce dangerously toxic gas.
- Confirm after installation that no refrigerant gas is leaking. If the gas comes in contact with a burning stove, gas water heater, electric room heater or other heat source, it can cause the generation of poisonous gas.

Check of Density Limit

The room in which the air conditioner is to be installed requires a design that in the event of refrigerant gas leaking out, its density will not exceed a set limit.

The refrigerant (R410A), which is used in the air conditioner, is safe, without the toxicity or combustibility of ammonia, and is not restricted by laws imposed to protect the ozone layer. However, since it contains more than air, it poses the risk of suffocation if its density should rise excessively. Suffocation from leakage of refrigerant is almost non-existent. With the recent increase in the number of high density buildings, however, the installation of multi air conditioner systems is on the increase because of the need for effective use of floor space, individual control, energy conservation by curtailing heat and carrying power, etc.

Most importantly, the multi air conditioner system is able to replenish a large amount of refrigerant compared to conventional individual air conditioners. If a single unit of the multi air conditioner system is to be installed in a small room, select a suitable model and installation procedure so that if the refrigerant accidentally leaks out, its density does not reach the limit (and in the event of an emergency, measures can be made before injury can occur).

In a room where the density may exceed the limit, create an opening with adjacent rooms, or install mechanical ventilation combined with a gas leak detection device. The density is as given below.

Total amount of refrigerant (oz)

$$\frac{\text{Min. volume of the indoor unit installed room (ft.}^3)}{\leq \text{Density limit (oz/ft.}^3)}$$

The density limit of refrigerant which is used in multi air conditioners is 0.3 oz/ft.³ (ISO 5149).

NOTE

- If there are 2 or more refrigerating systems in a single refrigerating device, the amount of refrigerant should be as charged in each independent device.

For the amount of charge in this example:

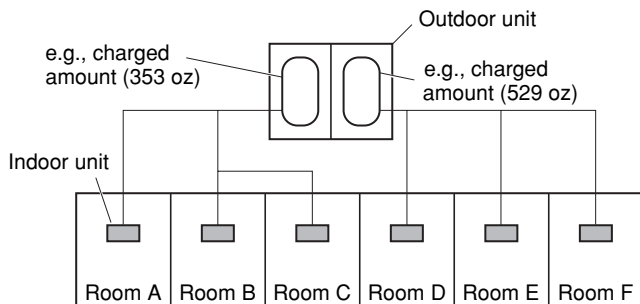

The possible amount of leaked refrigerant gas in rooms A, B and C is 353 oz.

The possible amount of leaked refrigerant gas in rooms D, E and F is 529 oz.

- The standards for minimum room volume are as follows.

- (1) No partition (shaded portion)

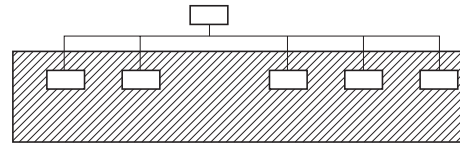

- (2) When there is an effective opening with the adjacent room for ventilation of leaking refrigerant gas (opening without a door, or an opening 0.15% or larger than the respective floor spaces at the top or bottom of the door).

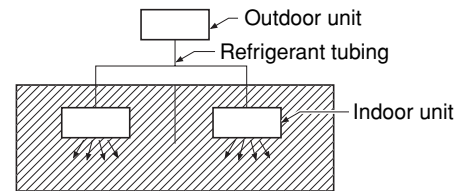

- (3) If an indoor unit is installed in each partitioned room and the refrigerant tubing is interconnected, the smallest room of course becomes the object. But when mechanical ventilation is installed interlocked with a gas leakage detector in the smallest room where the density limit is exceeded, the volume of the next smallest room becomes the object.

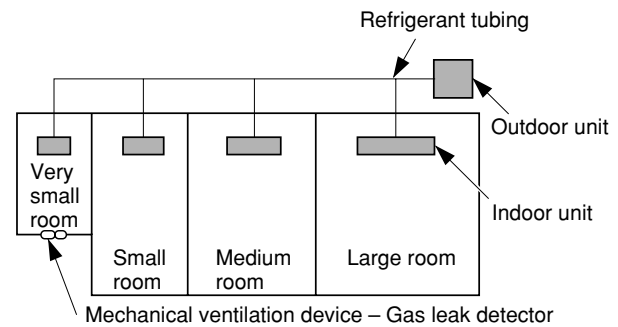

- The minimum indoor floor space compared with the amount of refrigerant is roughly as follows (when the ceiling is 8.8 ft. high):

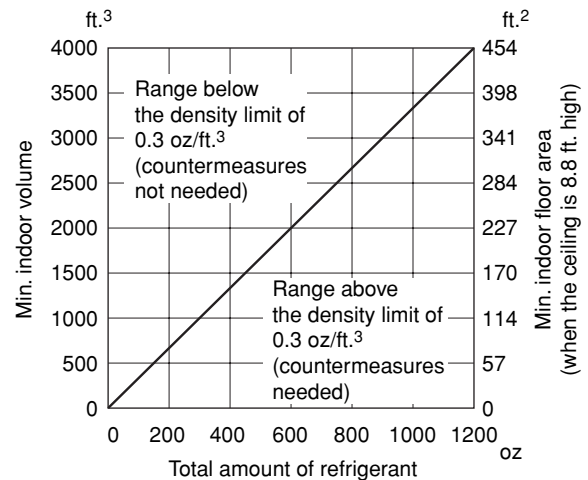

Precautions for Installation Using New Refrigerant

1. Care regarding tubing

1-1. Process tubing

- Material: Use C1220 phosphorous deoxidized copper specified in JIS H3300 "Copper and Copper Alloy Seamless Pipes and Tubes."
- **Tubing size: Be sure to use the sizes indicated in the table below.**
- Use a tube cutter when cutting the tubing, and be sure to remove any flash. This also applies to distribution joints (optional).
- When bending tubing, use a bending radius that is 4 times the outer diameter of the tubing or larger.



CAUTION

Use sufficient care in handling the tubing. Seal the tubing ends with caps or tape to prevent dirt, moisture, or other foreign substances from entering. These substances can result in system malfunction.

Unit: in. (mm)

Material		Ø				
Copper tube	Outer diameter	1/4 (6.35)	3/8 (9.52)	1/2 (12.7)	5/8 (15.88)	3/4 (19.05)
	Wall thickness	1/32 (0.8)	1/32 (0.8)	1/32 (0.8)	5/128 (1.0)	5/128 (1.0)

1-2. Prevent impurities including water, dust and oxide from entering the tubing. Impurities can cause R410A refrigerant deterioration and compressor defects. Due to the features of the refrigerant and refrigerating machine oil, the prevention of water and other impurities becomes more important than ever.

2. Be sure to recharge the refrigerant only in liquid form.

- 2-1. Since R410A is a non-azeotrope, recharging the refrigerant in gas form can lower performance and cause defects of the unit.
- 2-2. Since refrigerant composition changes and performance decreases when gas leaks, collect the remaining refrigerant and recharge the required total amount of new refrigerant after fixing the leak.

3. Different tools required

- 3-1. Tool specifications have been changed due to the characteristics of R410A.
Some tools for R22- and R407C-type refrigerant systems cannot be used.

Item	New tool?	R407C tools compatible with R410A?	Remarks
Manifold gauge	Yes	No	Types of refrigerant, refrigerating machine oil, and pressure gauge are different.
Charge hose	Yes	No	To resist higher pressure, material must be changed.
Vacuum pump	Yes	Yes	Use a conventional vacuum pump if it is equipped with a check valve. If it has no check valve, purchase and attach a vacuum pump adapter.
Leak detector	Yes	No	Leak detectors for CFC and HCFC that react to chlorine do not function because R410A contains no chlorine. Leak detector for HFC134a can be used for R410A.
Flaring oil	Yes	No	For systems that use R22, apply mineral oil (Suniso oil) to the flare nuts on the tubing to prevent refrigerant leakage. For machines that use R407C or R410A, apply synthetic oil (ether oil) to the flare nuts.

Manifold gauge

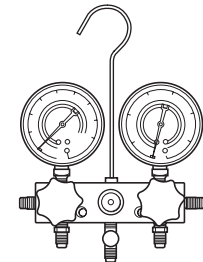

Vacuum pump

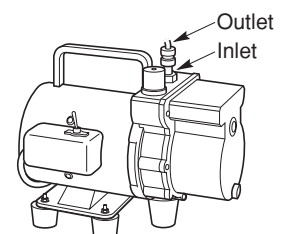

* Using tools for R22 and R407C and new tools for R410A together can cause defects.

3-2. Use R410A exclusive cylinder only.

Single-outlet valve

(with siphon tube)

Liquid refrigerant should be recharged with the cylinder standing on end as shown.

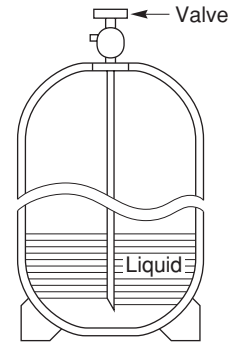

New refrigerant R410A cannot be used for earlier models

1. Compressor specifications are different.

If recharging a R22 or R407C compressor with R410A, durability will significantly decrease since some of the materials used for compressor parts are different.

2. Existing tubing cannot be used (especially R22).

Completely cleaning out residual refrigerating machine oil is impossible, even by flushing.

3. Refrigerating machine oil differs (R22).

Since R22 refrigerating machine oil is mineral oil, it does not dissolve in R410A. Therefore, refrigerating machine oil discharged from the compressor can cause compressor damage.

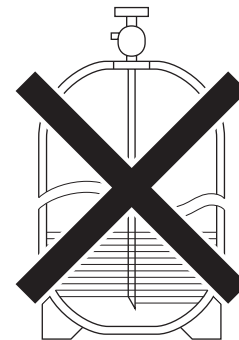

R410A

R22 refrigerating machine oil	Mineral oil (Suniso oil)
R407C refrigerating machine oil	Synthetic fluid (ether oil)
R410A refrigerating machine oil	Synthetic fluid (ether oil)

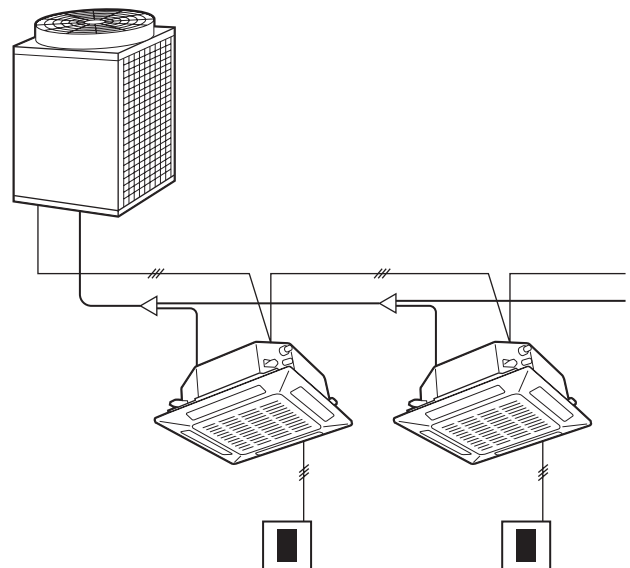

CONTENTS

	Page	Page
IMPORTANT	2	
Please Read Before Starting		
Check of Density Limit		
Precautions for Installation Using New Refrigerant		
1. GENERAL	8	
1-1. Tools Required for Installation (not supplied)		
1-2. Accessories Supplied		
1-3. Type of Copper Tube and Insulation Material		
1-4. Additional Materials Required for Installation		
1-5. Tubing Size		
1-6. Straight Equivalent Length of Joints		
1-7. Additional Refrigerant Charge		
1-8. System Limitations		
1-9. Tubing Length		
1-10. Check of Limit Density		
1-11. Installing Distribution Joint		
1-12. Optional Distribution Joint Kit		
1-13. Example of Tubing Size Selection and Refrigerant Charge Amount		
2. SELECTING THE INSTALLATION SITE	17	
2-1. Indoor Unit		
2-2. Outdoor Unit		
2-3. Air-Discharge Chamber for Top Discharge		
2-4. Installing the Unit in Heavy Snow Areas		
2-5. Precautions for Installation in Heavy Snow Areas		
2-6. Dimensions of Air-Discharge Chamber		
2-7. Dimensions of Outdoor Unit with Air-Discharge Chamber (field supply)		
2-8. Dimensions of Snow Ducting		
2-9. Dimensions of Outdoor Unit with Snow-Proof Ducting (field supply)		
3. HOW TO INSTALL THE INDOOR UNIT	25	
■ 4-Way Air Discharge Semi-Concealed Type (X Type)		
3-1. Preparation for Suspending		
3-2. Suspending the Indoor Unit		
3-3. Placing the Unit Inside the Ceiling		
3-4. Installing the Drain Piping		
3-5. Checking the Drainage		
3-6. How to Install the Ceiling Panel		
3-7. Special Remarks		
■ 1-Way Air Discharge Semi-Concealed Type (A Type)		
3-8. Suspending the Indoor Unit		
3-9. Placing the Unit Inside the Ceiling		
3-10. Installing the Drain Piping		
3-11. Checking the Drainage		
3-12. Electrical Power Wiring		
3-13. How to Install the Ceiling Panel		
■ Concealed Duct Type (U Type)		
3-14. Required Minimum Space for Installation and Service		
3-15. Suspending the Indoor Unit		
3-16. Installing the Drain Piping		
3-17. Checking the Drainage		
3-18. Increasing the Fan Speed		
■ Concealed Duct High-Static Pressure Type (D Type)		
3-19. Required Minimum Space for Installation and Service		
3-20. Suspending the Indoor Unit		
3-21. Installing the Drain Piping		
3-22. Caution for Ducting Work		
3-23. Indoor Fan Performance		
■ Ceiling-Mounted Type (T Type)		
3-24. Required Minimum Space for Installation and Service		
3-25. Suspending the Indoor Unit		
3-26. Duct for Fresh Air		
3-27. Shaping the Tubing		
3-28. Installing the Drain Piping		
■ Wall-Mounted Type (K Type)		
3-29. Removing the Rear Panel from the Unit		
3-30. Selecting and Making a Hole		
3-31. Installing the Rear Panel onto the Wall		
3-32. Removing the Grille to Install the Indoor Unit		
3-33. Preparing the Tubing		
3-34. Shaping the Tubing		
3-35. Installing the Drain Hose		
3-36. When Using Wireless Remote Controller Instead of Wired Remote Controller		
4. HOW TO INSTALL THE OUTDOOR UNIT ...	56	
4-1. Installing the Outdoor Unit		
4-2. Drainage Work		
4-3. Routing the Tubing and Wiring		
5. ELECTRICAL WIRING	57	
5-1. General Precautions on Wiring		
5-2. Recommended Wire Length and Wire Diameter for Power Supply System		
5-3. Wiring System Diagram		

6. HOW TO PROCESS TUBING	61
6-1. Connecting the Refrigerant Tubing	
6-2. Connecting Tubing Between Indoor and Outdoor Units	
6-3. Insulating the Refrigerant Tubing	
6-4. Taping the Tubes	
6-5. Finishing the Installation	
7. AIR PURGING	65
■ Air Purging with a Vacuum Pump (for Test Run) Preparation	
8. TEST RUN	68
8-1. Preparing for Test Run	
8-2. Test Run Procedure	
8-3. Outdoor Unit PCB Setting	
8-4. Auto Address Setting	
8-5. Caution for Pump Down	
8-6. Meaning of Alarm Messages	
9. APPENDIX	81
9-1. 4-Way Air Discharge Semi-Concealed Type (X Type)	
9-2. 1-Way Air Discharge Semi-Concealed Type (A Type)	
9-3. Concealed Duct (High-Static Pressure) Type (U, D Type)	
9-4. Ceiling-Mounted Type (T Type)	
9-5. Wall-Mounted Type (K Type)	

1. GENERAL

This booklet briefly outlines where and how to install the air conditioning system. Please read over the entire set of instructions for the outdoor unit and make sure all accessory parts listed are with the system before beginning.



1-1. Tools Required for Installation (not supplied)

1. Standard screwdriver
2. Phillips head screwdriver
3. Knife or wire stripper
4. Tape measure
5. Carpenter's level
6. Sabre saw or key hole saw
7. Hacksaw
8. Core bits
9. Hammer
10. Drill
11. Tube cutter
12. Tube flaring tool
13. Torque wrench
14. Adjustable wrench
15. Reamer (for deburring)

1-2. Accessories Supplied

See Tables 1-1 – 1-7.

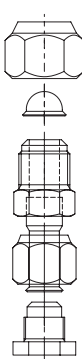
Table 1-1 (Outdoor Unit)

Part name	Figure	Q'ty	
		03652 Model (4 hp)	06052 Model (6 hp)
Tube Discharge Assy		0	1
Instruction manual	 paper	1	1

hp = horsepower

1-3. Type of Copper Tube and Insulation Material

If you wish to purchase these materials separately from a local source, you will need:

1. Deoxidized annealed copper tube for refrigerant tubing.
2. Foamed polyethylene insulation for copper tubes as required to precise length of tubing. Wall thickness of the insulation should be not less than 5/16 in.
3. Use insulated copper wire for field wiring. Wire size varies with the total length of wiring.

Refer to **5. ELECTRICAL WIRING** for details.



CAUTION

Check local electrical codes and regulations before obtaining wire. Also, check any specified instructions or limitations.

1-4. Additional Materials Required for Installation

1. Refrigeration (armored) tape
2. Insulated staples or clamps for connecting wire (See your local codes.)
3. Putty
4. Refrigeration tubing lubricant
5. Clamps or saddles to secure refrigerant tubing
6. Scale for weighing

Table 1-2 (4-Way Air Discharge Semi-Concealed)









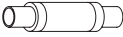

Part Name	Figure	Q'ty	Remarks
Full-scale installation diagram		1	Printed on container box
Drain hose		1	For securing drain hose
Hose band		1	For securing drain hose
Drain insulator		1	For drain joint
Flare insulator		1	For liquid tube
		1	For gas tube
Insulating tape	 White (heat-resisting)	2	For gas tube joint
Packing		1	For drain joint
Wiring cover		1	For covering electrical wiring
Screw		4	For full-scale installation diagram
Washer		8	For suspending indoor unit from ceiling
Screw		1	For fixing the wiring cover

Table 1-3 (1-Way Air Discharge Semi-Concealed)



















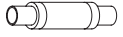

Part Name	Figure	Q'ty	Remarks
Full-scale installation diagram		1	Printed on container box
Drain hose		1	For securing drain hose
Hose band		1	For securing drain hose
Drain insulator		1	For drain joint
Flare insulator		1	For liquid tube
		1	For gas tube
Insulating tape	 White (heat-resisting)	2	For gas tube joint
Packing		1	For drain joint
Washer		8	For suspending indoor unit from ceiling
Screw		4	For full-scale installation diagram
Bushing		1	For electrical junction box

Table 1-4 (Concealed Duct)

Part Name	Figure	Q'ty	Remarks
Drain hose		1	For securing drain hose
Hose band		1	For securing drain hose
Packing		1	For drain joint
Drain insulator		1	For drain joint
Flare insulator		1	For liquid tube
Insulating tape	 White (heat-resisting)	2	For gas and liquid tubes flare nuts
Flare insulator		1	For gas tube
Washer		8	For suspending indoor unit from ceiling
Sealing putty		1	For sealing recessed portion of power supply
Vinyl clamp		8	For flare and drain insulators

- Use 3/8" for suspending bolts.
- Field supply for suspending bolts and nuts.

Table 1-5 (Concealed Duct High-Static Pressure)





Part Name	Figure	Q'ty	Remarks
Washer		8	For suspending indoor unit from ceiling
Nut		8	For suspending indoor unit from ceiling
Flare insulator		1	For gas tube
		1	For liquid tube
Drain socket		1	For drain pipe connection

Table 1-6 (Ceiling-Mounted)













Part Name	Figure	Q'ty	Remarks
Full-scale installation diagram		1	Printed on container box
Washer		4	For temporarily suspending indoor unit from ceiling
Flare insulator	 T1/8"	2	For gas and liquid tube joints
	 T3/16"	2	
Insulating tape	 White (heat-resisting)	2	For gas and liquid tubes flare nuts
Vinyl clamp		8	For flare and drain insulators
Drain hose	 L5-1/2"	1	For main unit and PVC pipe joints
Hose band		2	For drain hose connection
Drain insulator		1	For drain hose joint
Gum eyelet		1	For power supply inlet

Table 1-7 (Wall-Mounted)

Part Name	Figure	Q'ty	Remarks
Tapping screw	 5/32" x 1"	10	For fixing the rear panel
Plastic cover		1	For improved tubing appearance
Insulator		1	For insulating flare nut (2452 type only)

1-5. Tubing Size

Table 1-8 Main Tubing Size (LA)

BTU/h (kW)	38,200 (11.2)	52,900 (15.5)
System horsepower	4	6
Gas tubing	ø5/8" (ø15.88)	ø3/4" (ø19.05)
Liquid tubing	ø3/8" (ø9.52)	

Unit: in. (mm)

Table 1-9 Main Tubing Size After Distribution (LB, LC...)

Total capacity after distribution	Below BTU/h	24,200 (2.5 hp)	38,200 (4 hp)	47,800 (5 hp)	52,900 (6 hp)
	Over BTU/h	-			
Tubing size	Gas tubing	ø1/2" (ø12.7)	ø5/8" (ø15.88)		ø3/4" (ø19.05)
	Liquid tubing	ø3/8" (ø9.52)			

Unit: in. (mm)
hp = horsepower

Note: In case the total capacity of connected indoor units exceeds the total capacity of the outdoor units, select the main tubing size for the total capacity of the outdoor units.

Table 1-10 Indoor Unit Tubing Connection (l₁, l₂... l_{n-1})

Indoor unit type	7	9	12	18	24	36	48
Gas tubing	ø1/2" (ø12.7)			ø5/8" (ø15.88)			
Liquid tubing	ø1/4" (ø6.35)			ø3/8" (ø9.52)			

Unit: in. (mm)

1-6. Straight Equivalent Length of Joints

Design the tubing system by referring to the following table for the straight equivalent length of joints.

Table 1-11 Straight Equivalent Length of Joints

Unit: ft.





Gas tubing size (in. (mm))		1/2" (12.7)	5/8" (15.88)	3/4" (19.05)
90° elbow		1	1.1	1.4
45° elbow		0.8	0.9	1
U-shape tube bend (R2-3/8" – 4" (60 – 100))		3	3.4	4.1
Trap bend		7.5	9.2	10.5
Y-branch distribution joint		Equivalent length conversion not needed.		
Ball valve for service		Equivalent length conversion not needed.		

Table 1-12 Required Copper Tubing Dimensions

Unit: in. (mm)

Material		Ø				
Copper tube	Outer diameter	1/4 (6.35)	3/8 (9.52)	1/2 (12.7)	5/8 (15.88)	3/4 (19.05)
	Wall thickness	1/32 (0.8)	1/32 (0.8)	1/32 (0.8)	5/128 (1.0)	over 5/128 (1.0)

1-7. Additional Refrigerant Charge

Additional refrigerant charge amount is calculated from the liquid tubing total length as follows.

Table 1-13 Amount of Refrigerant Charge Per Meter, According to Liquid Tubing Size

Liquid tubing size (in. (mm))	Amount of refrigerant charge (oz/ft.)
ø1/4" (ø6.35)	0.279
ø3/8" (ø9.52)	0.602

Required amount of charge = (Amount of refrigerant charge per meter of each size of liquid tube × its tube length) + (...) + (...)

*Always charge accurately using a scale for weighing.

Table 1-14 Refrigerant Charge Amount at Shipment (for outdoor unit)

Heat pump unit (Single-phase) (oz)	CHX03652	CHX06052
	123	123

1-8. System Limitations

Table 1-15 System Limitations

Outdoor units (Type)	CHX03652	CHX06052
Number of max. connectable indoor units	6	9
Max. allowable indoor/outdoor capacity ratio	50 – 130%	

1-9. Tubing Length

Select the installation location so that the length and size of refrigerant tubing are within the allowable range shown in the figure below.

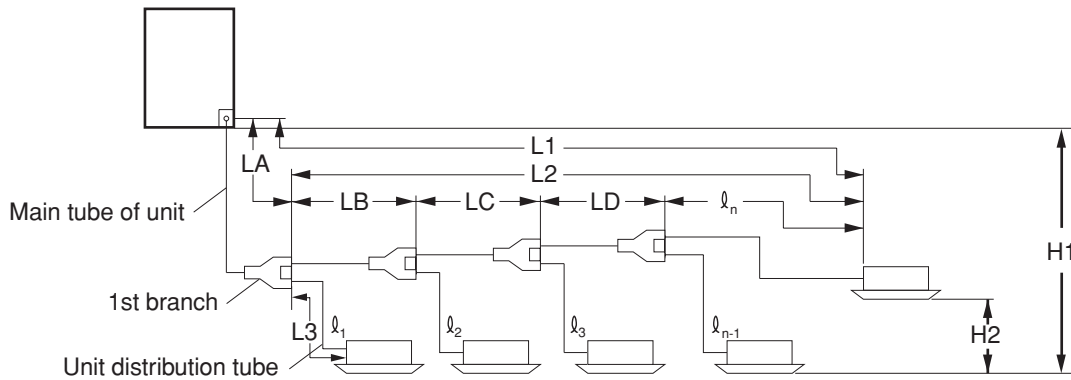

Note: Do not use commercially available T-joints for the liquid tubing.

* Be sure to use special R410A distribution joints (APR: purchased separately) for outdoor unit connections and tubing branches.

R410A distribution joint
APR-P160BA (for indoor unit)

Table 1-16 Ranges that Apply to Refrigerant Tubing Lengths and to Differences in Installation Heights

Items	Marks	Contents	Length (ft.)	
Allowable tubing length	L1	Max. tubing length	Actual length	≤ 492
			Equivalent length	≤ 574
	$\Delta L (L2 - L3)$	Difference between max. length and min. length from the No.1 distribution joint	≤ 131	
	$l_1, l_2 \dots l_n$	Max. length of each distribution tube	≤ 98	
	$l_1 + l_2 + \dots l_{n-1} + L1$	Total max. tubing length including length of each distribution tube (only narrow tubing)	≤ 656	
Allowable elevation difference	H1	When outdoor unit is installed higher than indoor unit	≤ 164	
		When outdoor unit is installed lower than indoor unit	≤ 131	
	H2	Max. difference between indoor units	≤ 49	

L = Length, H = Height



WARNING

Always check the gas density limit for the room in which the unit is installed.

1-10. Check of Limit Density

When installing an air conditioner in a room, it is necessary to ensure that even if the refrigerant gas accidentally leaks out, its density does not exceed the limit level for that room.

If the density could exceed the limit level, it is necessary to provide an opening between the unit and the adjacent room, or to install mechanical ventilation which is interlocked with the leak detector.

(Total refrigerant charged amount: oz)

$$\frac{\text{(Min. indoor volume where the indoor unit is installed: ft.}^3\text{)}}{\leq \text{Limit density 0.3 (oz/ft.}^3\text{)}}$$

The limit density of refrigerant which is used in this unit is 0.3 oz/ft.³ (ISO 5149).

The shipped outdoor unit comes charged with the amount of refrigerant fixed for each type, so add it to the amount that is charged in the field. (For the refrigerant charge amount at shipment, refer to the unit's nameplate.)



CAUTION

Pay special attention to any location, such as a basement, etc., where leaking refrigerant can accumulate, since refrigerant gas is heavier than air.

1-11. Installing Distribution Joint

- (1) Refer to "HOW TO ATTACH DISTRIBUTION JOINT" enclosed with the optional distribution joint kit (APR-P160BA).
- (2) In order to prevent accumulation of refrigerant oil in stopped units, if the main tubing is horizontal then each branch tubing length should be at an angle that is greater than horizontal. If the main tubing is vertical, provide a raised starting portion for each branch.
- (3) If there are height differences between indoor units or if branch tubing that follows a distribution joint is connected to only 1 unit, a trap or ball valve must be added to that distribution joint. (When adding the ball valve, locate it within 1.3 ft. of the distribution joint.) (Consult with SANYO separately concerning the ball valve.)

If a trap or ball valve is not added, do not operate the system before repairs to a malfunctioning unit are completed. (The refrigerant oil sent through the tubing to the malfunctioning unit will accumulate and may damage the compressor.)

Minimum indoor volume & floor area as against the amount of refrigerant is roughly as given in the following table.

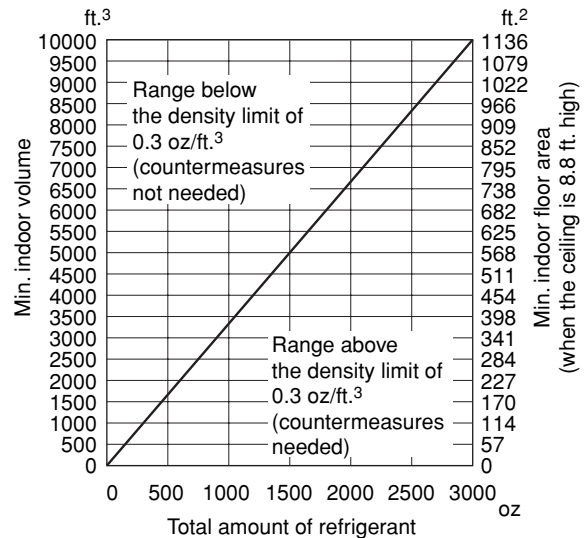

Tube branching methods (horizontal use)

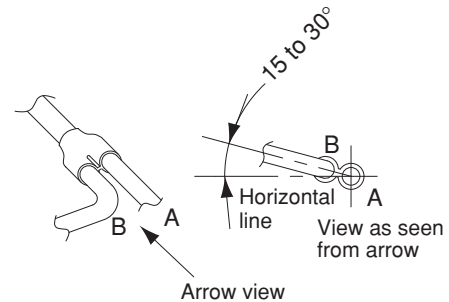

Types of vertical trap specifications

(When using ball valve)

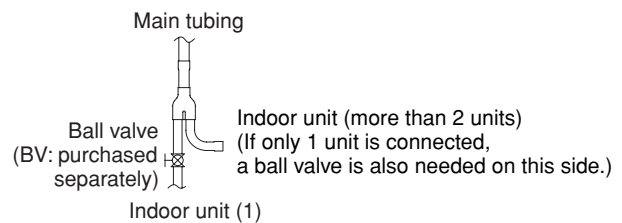

(When not using ball valve)

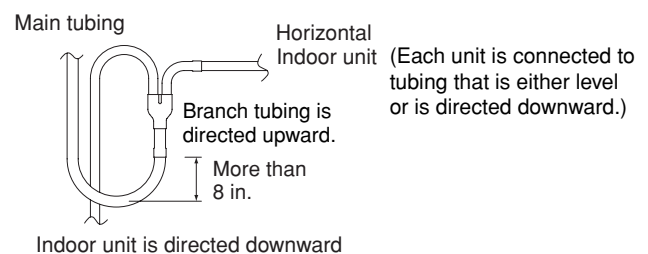

1-12. Optional Distribution Joint Kit

See the installation instructions packaged with the distribution joint kit for the installation procedure.

Table 1-17

Model name	Cooling capacity after distribution	Remarks
APR-P160BA	76,400 BTU/h (22.4 kW) or less	For indoor unit

APR-P160BA

Use: For indoor unit (Capacity after distribution joint is 76,400 BTU/h (22.4 kW) or less.)

Example

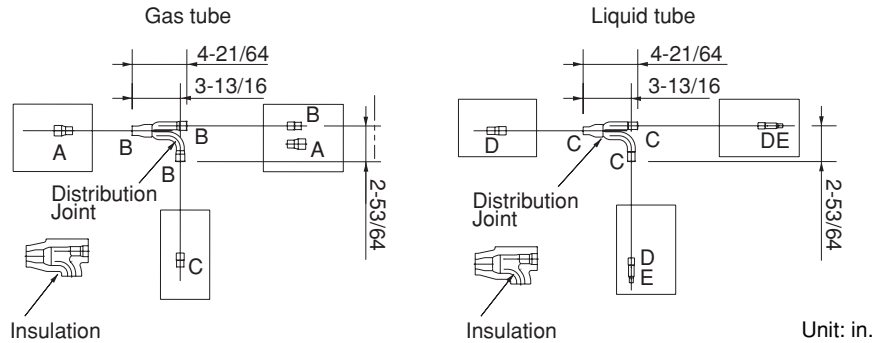

Table 1-18 Size of connection point on each part (Shown are inside diameters of tubing)

Size	Part A	Part B	Part C	Part D	Part E
in. (mm)	ø3/4" (ø19.05)	ø5/8" (ø15.88)	ø1/2" (ø12.7)	ø3/8" (ø9.52)	ø1/4" (ø6.35)

1-13. Example of Tubing Size Selection and Refrigerant Charge Amount

Additional refrigerant charging

Based on the values in Tables 1-2, 1-3, 1-4 and 1-7, use the liquid tubing size and length, and calculate the amount of additional refrigerant charge using the formula below.

$$\text{Required additional refrigerant charge (oz)} = 0.602 \times (a) + 0.279 \times (b)$$

(a): Liquid tubing Total length of $\varnothing 3/8$ " (ft.) (b): Liquid tubing Total length of $\varnothing 1/4$ " (ft.)

● Charging procedure

Be sure to charge with R410A refrigerant **in liquid form**.

1. After performing a vacuum, charge with refrigerant from the liquid tubing side. At this time, all valves must be in the "fully closed" position.
2. If it was not possible to charge the designated amount, operate the system in Cooling mode while charging with refrigerant from the gas tubing side. (This is performed at the time of the test run. For this, all valves must be in the "fully open" position.)

Charge with R410A refrigerant in liquid form.

With R410A refrigerant, charge while adjusting the amount being fed a little at a time in order to prevent liquid refrigerant from backing up.

- After charging is completed, turn all valves to the "fully open" position.
- Replace the tubing covers as they were before.

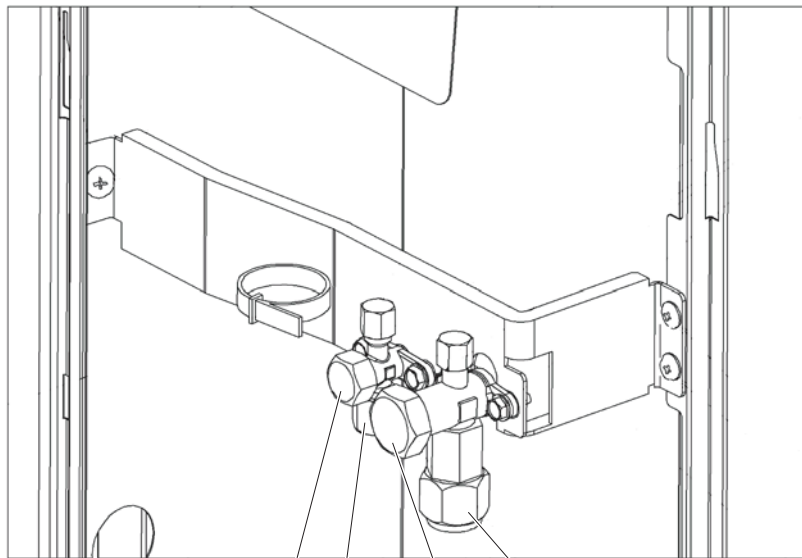

Tightening torque for valve stem cap: 160 – 180 lbs·in. ④ ① Tightening torque: 590 – 710 lbs·in.

Tightening torque: 300 – 360 lbs·in. ③ ② Tightening torque for valve stem cap: 240 – 280 lbs·in.



CAUTION

1. **R410A additional charging absolutely must be done through liquid charging.**
2. **The R410A refrigerant cylinder has a gray base color, and the top part is pink.**
3. **The R410A refrigerant cylinder includes a siphon tube. Check that the siphon tube is present. (This is indicated on the label at the top of the cylinder.)**
4. **Due to differences in the refrigerant, pressure, and refrigerant oil involved in installation, it is not possible in some cases to use the same tools for R22 and for R410A.**

Example:

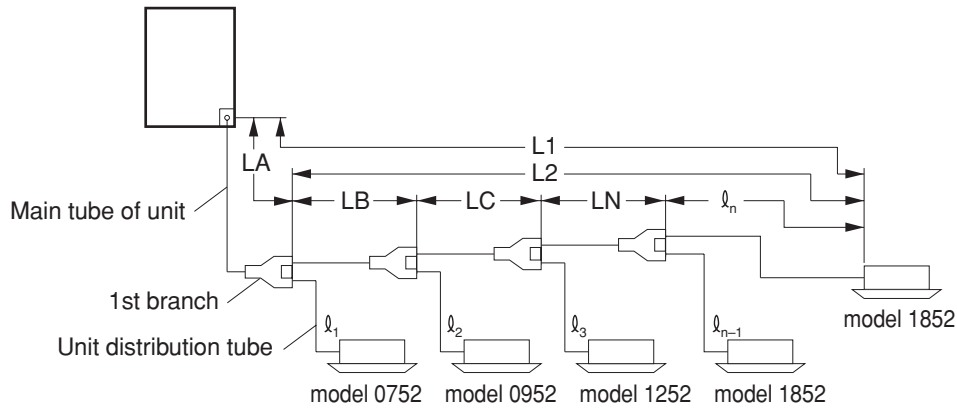

- Example of each tubing length

Main tubing	Distribution joint tubing	
LA = 131 ft.	Indoor side	
LB = 16 ft.	ℓ 1 = 16 ft.	ℓ 4 = 20 ft.
LC = 16 ft.	ℓ 2 = 16 ft.	ℓ 5 = 16 ft.
LD = 49 ft.	ℓ 3 = 7 ft.	

- Obtain charge amount for each tubing size

Note that the charge amounts per 3.3 ft. are different for each liquid tubing size.

$$\varnothing 3/8" (\varnothing 9.52) \rightarrow LA + LB + LC + LD : 212 \text{ ft.} \times 0.602 \text{ oz./ft.} = 127 \text{ oz}$$

$$\varnothing 1/4" (\varnothing 6.35) \rightarrow \ell_1 + \ell_2 + \ell_3 + \ell_4 + \ell_5 : 75 \text{ ft.} \times 0.279 \text{ oz./ft.} = 20 \text{ oz}$$

Total 147 oz

Additional refrigerant charge amount is 147 oz.



CAUTION

Be sure to check the limit density for the room in which the indoor unit is installed.

Checking of limit density

Density limit is determined on the basis of the size of a room using an indoor unit of minimum capacity. For instance, when an indoor unit is used in a room (floor area 80 ft² × ceiling height 8.8 ft. = room volume 704 ft.³), the graph at right shows that the minimum room volume should be 497 ft.³ (floor area 56 ft.²) for refrigerant of 147 oz. Accordingly, openings such as louvers are required for this room.

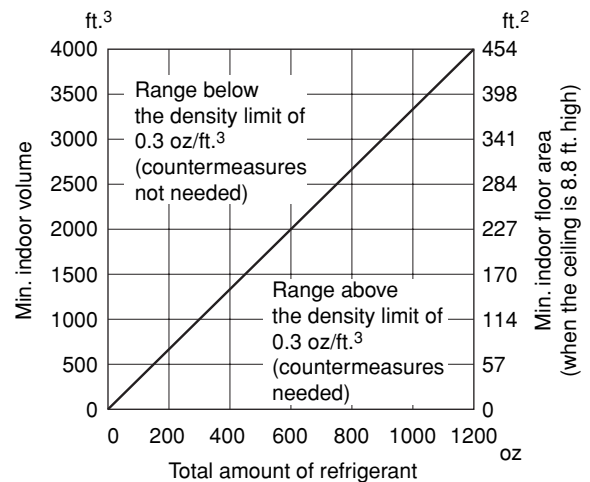

<Determination by calculation>

Overall refrigerant charge amount for the air conditioner: oz

(Minimum room volume for indoor unit: ft.³)

$$= \frac{147 \text{ (oz)} + 123 \text{ (oz)}}{704 \text{ (ft.}^3)} = 0.38 \text{ (oz./ft.}^3) \geq 0.3 \text{ (oz./ft.}^3)$$

Therefore, openings such as louvers are required for this room.

2. SELECTING THE INSTALLATION SITE

2-1. Indoor Unit

AVOID:

- areas where leakage of flammable gas may be expected.
- places where large amounts of oil mist exist.
- direct sunlight.
- locations near heat sources which may affect the performance of the unit.
- locations where external air may enter the room directly. This may cause “sweating” on the air discharge ports, causing them to spray or drip.
- locations where the remote controller will be splashed with water or affected by dampness or humidity.
- installing the remote controller behind curtains or furniture.
- locations where high-frequency emissions are generated.

DO:

- select an appropriate position from which every corner of the room can be uniformly cooled.
- select a location where the ceiling is strong enough to support the weight of the unit.
- select a location where tubing and drain pipe have the shortest run to the outdoor unit.
- allow room for operation and maintenance as well as unrestricted air flow around the unit.
- install the unit within the maximum elevation difference above or below the outdoor unit and within a total tubing length (L) from the outdoor unit as detailed in Table 1-16.
- allow room for mounting the remote controller about 3 ft. off the floor, in an area that is not in direct sunlight nor in the flow of cool air from the indoor unit.

NOTE

Air delivery will be degraded if the distance from the floor to the ceiling is greater than 10 ft.

Ceiling-Mounted Type

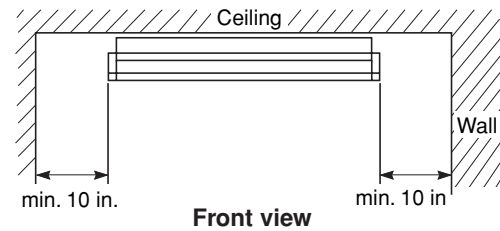

NOTE

The rear of the indoor unit can be installed against the wall.

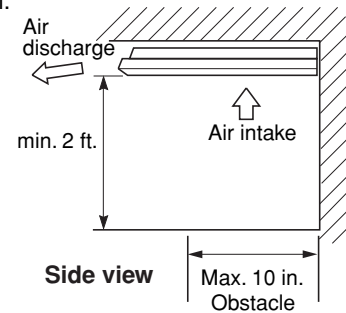

Fig. 2-1

Concealed Duct (High-Static Pressure) Type 4-Way Air Discharge Semi-Concealed Type

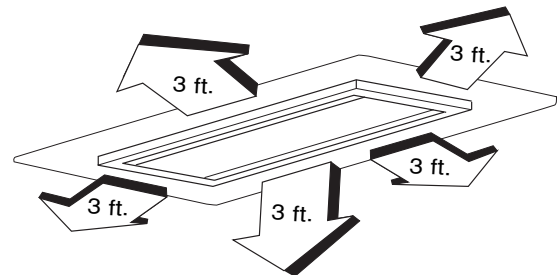

Fig. 2-2

1-Way Air Discharge Semi-Concealed Type

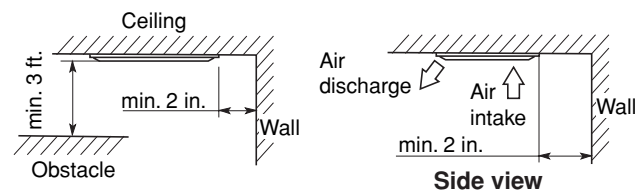
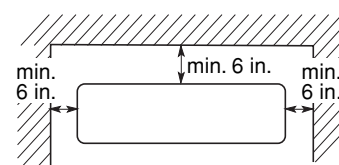

Fig. 2-3

Wall-Mounted Type



Front View

Fig. 2-4

2-2. Outdoor Unit

AVOID:

- heat sources, exhaust fans, etc. (Fig. 2-5)
- damp, humid or uneven locations

DO:

- choose a place as cool as possible.
- choose a place that is well ventilated and outside air temperature does not exceed maximum 113°F constantly.
- allow enough room around the unit for air intake/exhaust and possible maintenance. (Fig. 2-6)
- use lug bolts or equal to bolt down unit, reducing vibration and noise.

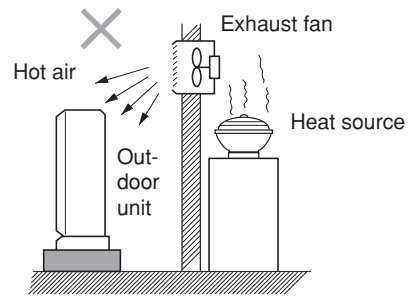

Fig. 2-5

Installation space

Distance between obstructions and the unit air inlet and outlet must be as shown below.

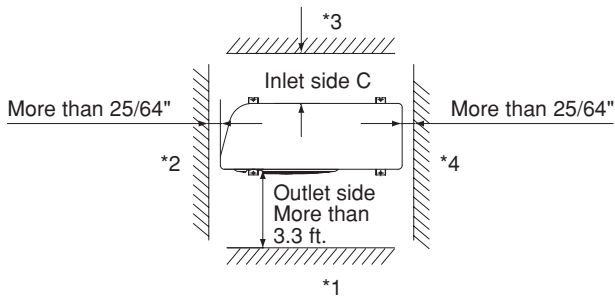

Fig. 2-6

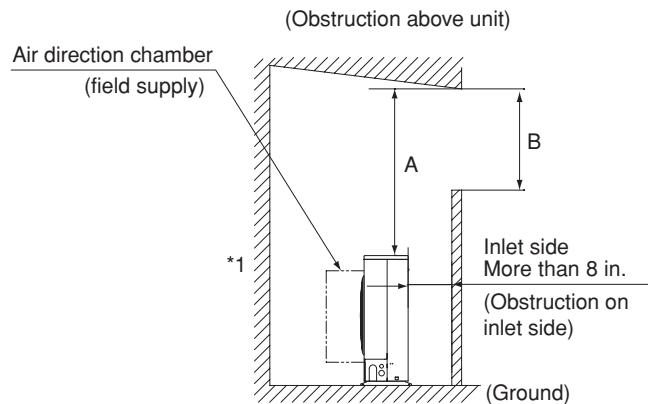

Fig. 2-7



CAUTION

- Concerning inlet-side distance "C" (Fig. 2-6) The minimum for distance "C" is 6 in. if there are no obstructions on the outlet side (wall *1 side) and *2 or *4 is not present. In all other cases, the minimum for distance "C" is 8 in.
- If the unit is installed with the outlet side facing wall *1, then there must be no obstructions on 2 of the remaining 3 sides: *2, *3, *4.
- If wall *1 is on the outlet side (Fig. 2-6), or if obstructions are present on all 3 sides *2, *3, and *4 (Fig. 2-6), then the minimum distance for "A" and "B" is 6.6 ft. (Fig. 2-8). Even if there is no wall on the outlet side, a minimum of 3.3 ft. is required.

In case of multiple installations

- provide a solid base (concrete block, 4 × 16 in. beams or equal), a minimum of 6 in. above ground level to reduce humidity and protect the unit against possible water damage and decreased service life. (Fig. 2-8)
- use lug bolts or equal to bolt down unit, reducing vibration and noise.

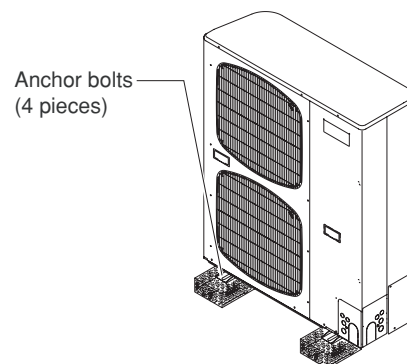

Fig. 2-8

2-3. Air Discharge Chamber for Top Discharge

Be sure to install an air discharge chamber (field supply) in the field when:

- it is difficult to keep a space of min. 20 in. between the air discharge outlet and an obstacle.
- the air discharge outlet is facing a sidewalk and discharged hot air may annoy passers-by. Refer to Fig. 2-10.

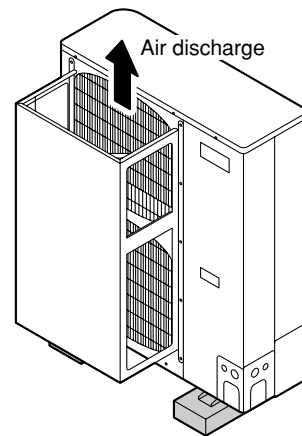

Fig. 2-10

2-4. Installing the Unit in Heavy Snow Areas

In locations with strong wind, snow-proof ducting (field supply) should be fitted and direct exposure to the wind should be avoided as much as possible.

■ Countermeasures against snow and wind

In regions with snow and strong wind, the following problems may occur when the outdoor unit is not provided with a platform and snow-proof ducting:

- a) The outdoor fan may not run and damage to the unit may occur.
- b) There may be no air flow.
- c) The tubing may freeze and burst.
- d) The condenser pressure may drop because of strong wind, and the indoor unit may freeze.

2-5. Precautions for Installation in Heavy Snow Areas

- (1) The platform should be higher than the max. snow depth. (Fig. 2-11)
- (2) The 2 anchoring feet of the outdoor unit should be used for the platform, and the platform should be installed beneath the air intake side of outdoor unit.
- (3) The platform foundation must be firm and the unit must be secured with anchor bolts.
- (4) In case of installation on a roof subject to strong wind, countermeasures must be taken to prevent the unit from being blown over.

In regions with significant snowfall, the outdoor unit should be provided with a platform and snow-proof ducting.

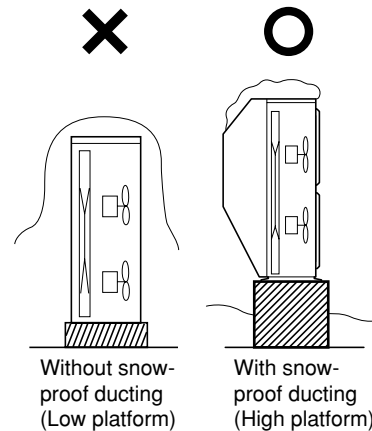

Fig. 2-11

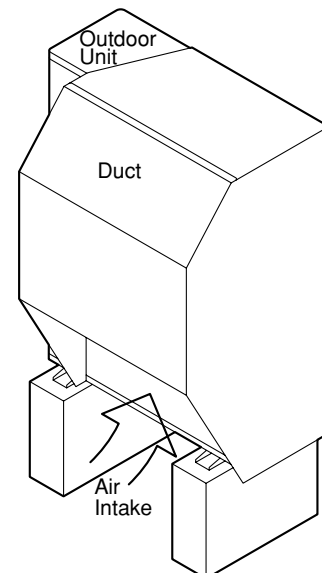
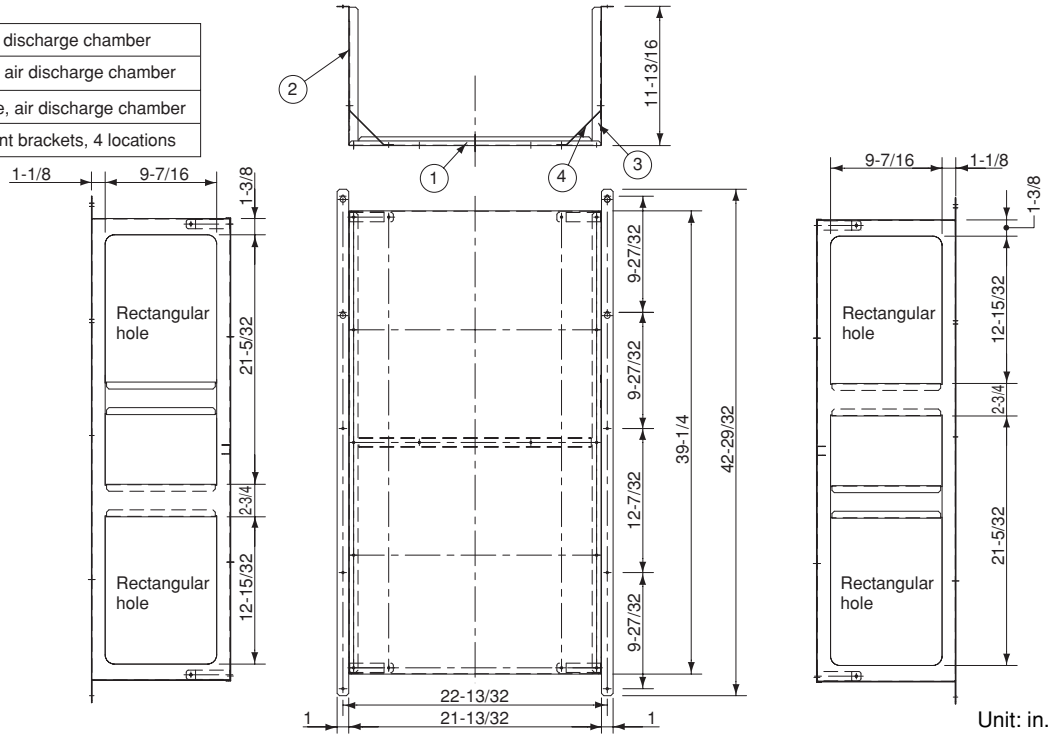

Fig. 2-12

2-6. Dimensions of Air-Discharge Chamber
Reference diagram for air-discharge chamber (field supply)
CHX03652/06052

①	Unit front, air discharge chamber
②	Unit left side, air discharge chamber
③	Unit light side, air discharge chamber
④	Reinforcement brackets, 4 locations



2-7. Dimensions of Outdoor Unit with Air-Discharge Chamber (field supply)
CHX03652/06052

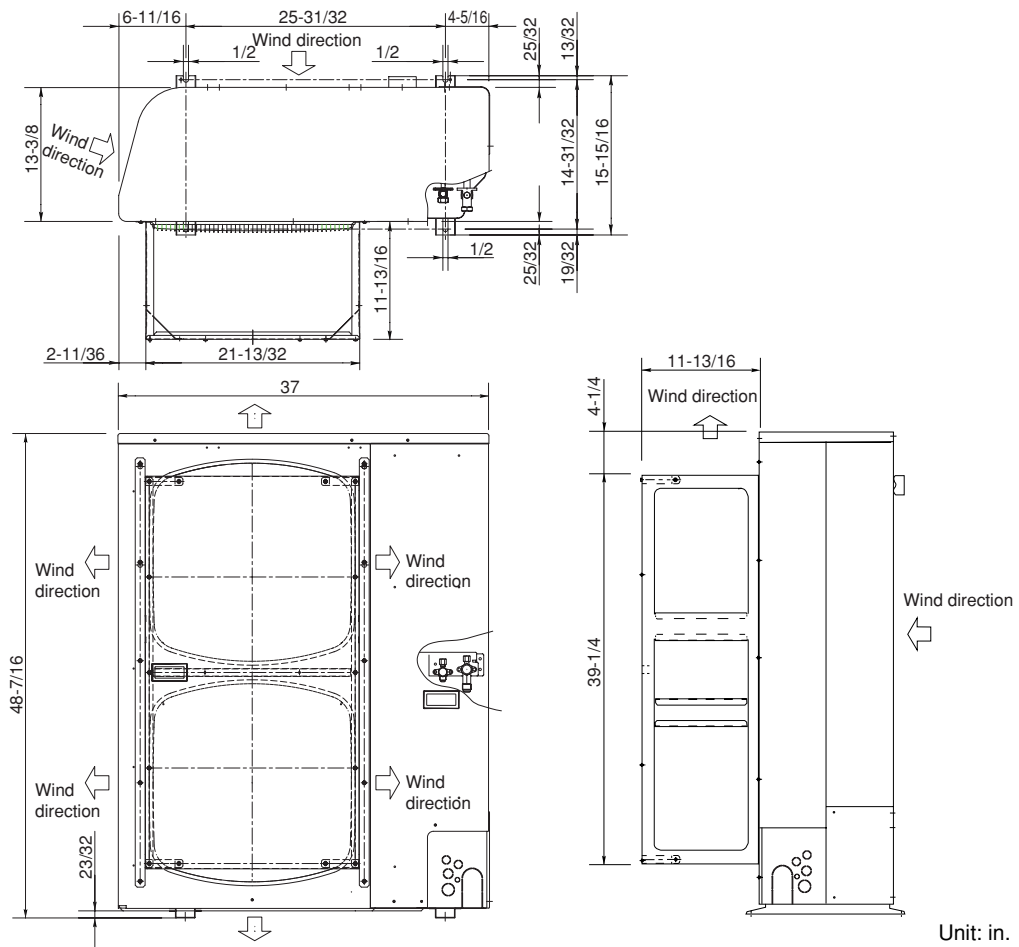

Reference for air-discharge chamber (field supply)

Required space around outdoor unit

CHX03652/06052

If an air discharge chamber is used, the space shown below must be secured around the outdoor unit.
If the unit is used without the required space, a protective device may activate, preventing the unit from operating.

(1) Single-unit installation

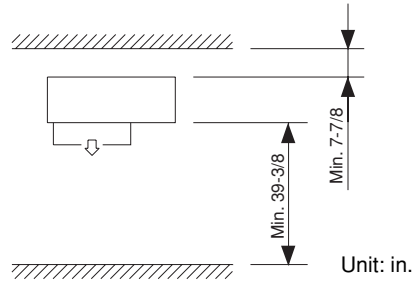

CAUTION

The top and both sides must remain open.
If there are obstacles to the front and rear of the outdoor unit, the obstacle at either the front or rear must be no taller than the height of the outdoor unit.

(2) Multiple-unit installation

- Installation in lateral rows

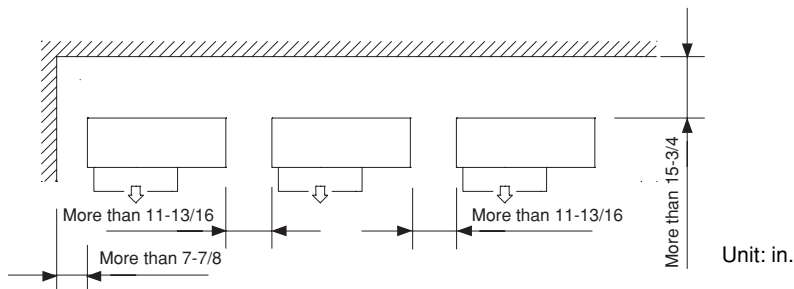

CAUTION

The front and top must remain open.
The obstacles must be no taller than the height of the outdoor unit.

- Installation in front-rear rows

Installation with intakes facing
intakes or outlets facing outlets

Installation with intakes facing outlets

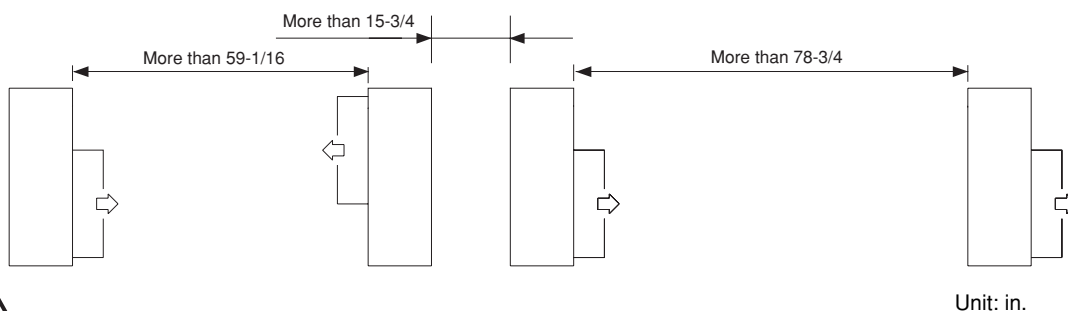

CAUTION

The front and both sides must remain open.

2-8. Dimensions of Snow Ducting

Reference diagram for snow-proof ducting (field supply)

CHX03652/06052

①	Unit top, snow-proof vent
②	Unit left side
③	Unit right side
④	Unit reverse side

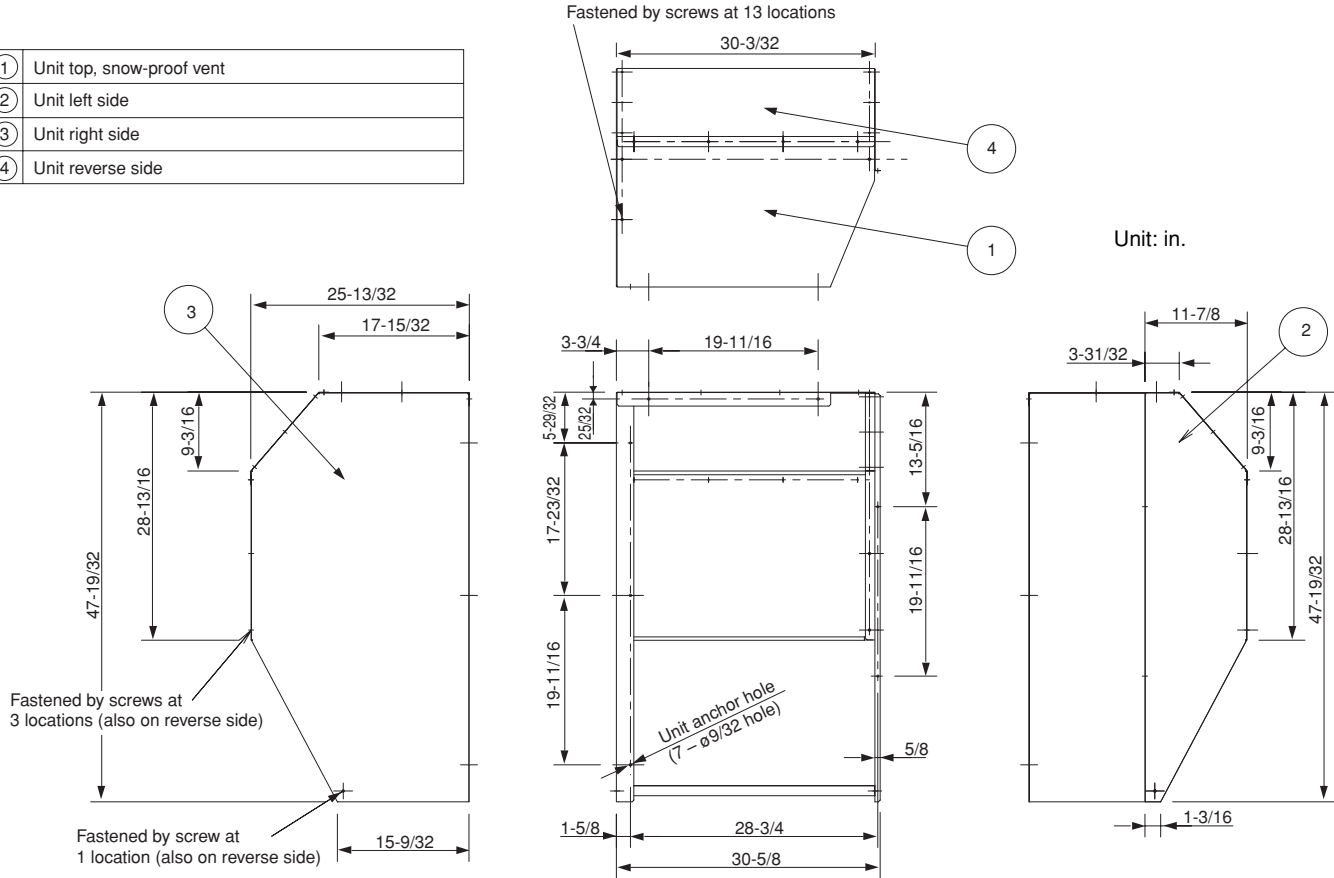

2-9. Dimensions of Outdoor Unit with Snow-Proof Ducting (field supply)

CHX03652/06052

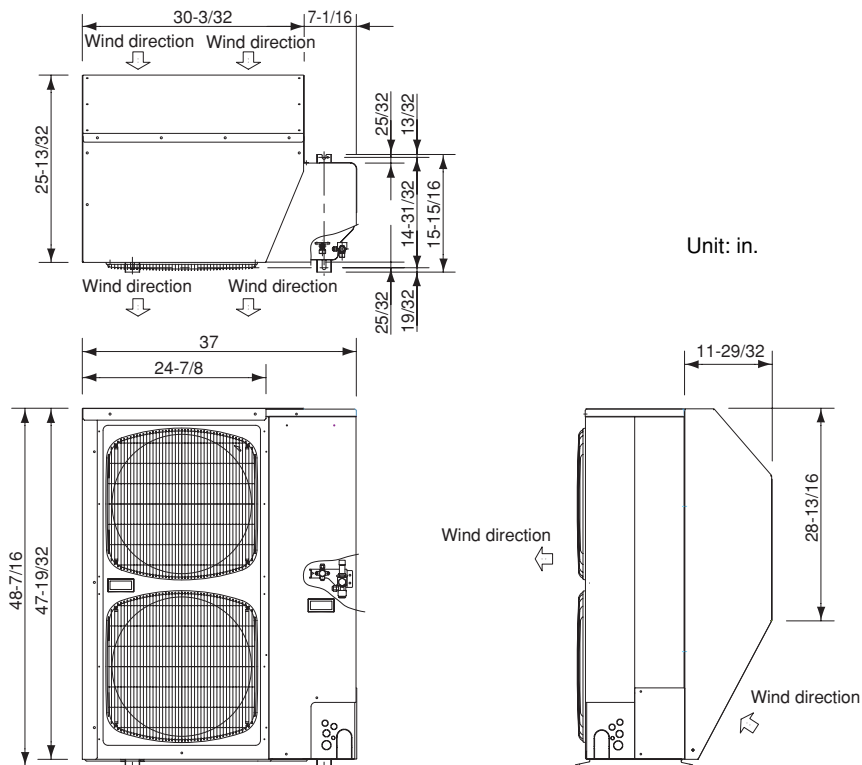

Reference diagram for snow-proof ducting – 1

Space requirements for setting – (1)
CHX03652/06052

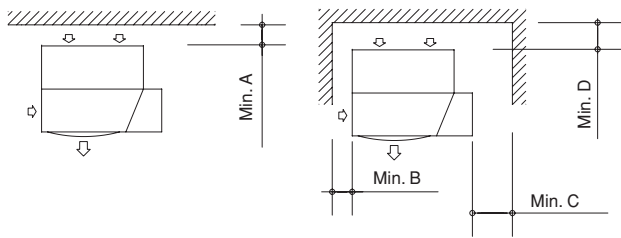
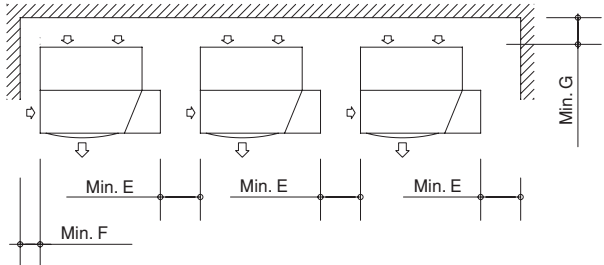
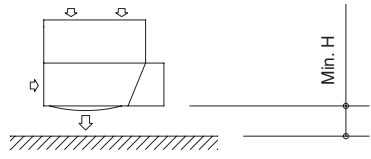
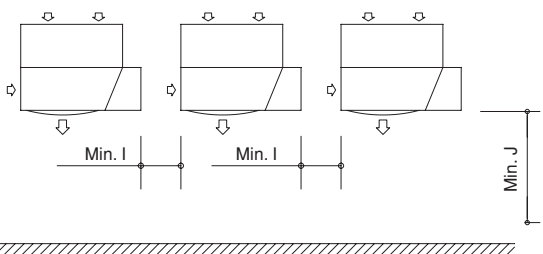
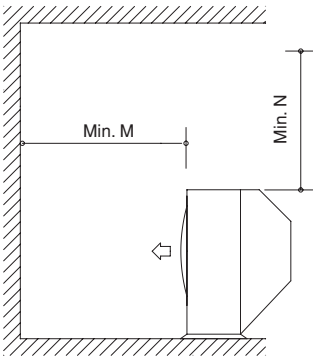
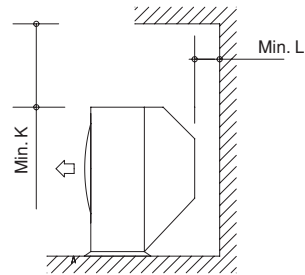
[Obstacle to the rear of unit]	[Obstacle to the front of unit]																								
<p>● Top is open:</p> <p>(1) Single-unit installation (2) Obstacles on both sides</p>  <p>(3) Multiple-unit installation (2 or more units)</p>  <table border="1" style="width: 100%; border-collapse: collapse; margin-top: 10px;"> <thead> <tr> <th>Outdoor unit</th> <th>A</th> <th>B</th> <th>C</th> <th>D</th> <th>E</th> <th>F</th> <th>G</th> </tr> </thead> <tbody> <tr> <td>CHX03652/06052</td> <td>5-29/32</td> <td>5-29/32</td> <td>11-13/16</td> <td>7-7/8</td> <td>11-13/16</td> <td>5-29/32</td> <td>7-7/8</td> </tr> </tbody> </table>	Outdoor unit	A	B	C	D	E	F	G	CHX03652/06052	5-29/32	5-29/32	11-13/16	7-7/8	11-13/16	5-29/32	7-7/8	<p>● Top is open:</p> <p>(1) Single-unit installation</p>  <p>(2) Multiple-unit installation (2 or more units)</p>  <table border="1" style="width: 100%; border-collapse: collapse; margin-top: 10px;"> <thead> <tr> <th>Outdoor unit</th> <th>H</th> <th>I</th> <th>J</th> </tr> </thead> <tbody> <tr> <td>CHX03652/06052</td> <td>19-11/16</td> <td>11-13/16</td> <td>39-3/8</td> </tr> </tbody> </table>	Outdoor unit	H	I	J	CHX03652/06052	19-11/16	11-13/16	39-3/8
Outdoor unit	A	B	C	D	E	F	G																		
CHX03652/06052	5-29/32	5-29/32	11-13/16	7-7/8	11-13/16	5-29/32	7-7/8																		
Outdoor unit	H	I	J																						
CHX03652/06052	19-11/16	11-13/16	39-3/8																						
<p>Note: In cases 2 and 3 the height of the obstacle must be no taller than the height of the outdoor unit.</p>	<p>● Top is blocked by an obstacle:</p>  <table border="1" style="width: 100%; border-collapse: collapse; margin-top: 10px;"> <thead> <tr> <th>Outdoor unit</th> <th>M</th> <th>N</th> </tr> </thead> <tbody> <tr> <td>CHX03652/06052</td> <td>39-3/8</td> <td>39-3/8</td> </tr> </tbody> </table>	Outdoor unit	M	N	CHX03652/06052	39-3/8	39-3/8																		
Outdoor unit	M	N																							
CHX03652/06052	39-3/8	39-3/8																							
<p>● Top is blocked by an obstacle:</p>  <table border="1" style="width: 100%; border-collapse: collapse; margin-top: 10px;"> <thead> <tr> <th>Outdoor unit</th> <th>K</th> <th>L</th> </tr> </thead> <tbody> <tr> <td>CHX03652/06052</td> <td>19-11/16</td> <td>5-29/32</td> </tr> </tbody> </table>	Outdoor unit	K	L	CHX03652/06052	19-11/16	5-29/32																			
Outdoor unit	K	L																							
CHX03652/06052	19-11/16	5-29/32																							

Unit: in.

Reference diagram for snow-proof ducting – 2

Space requirements for setting – (2)

CHX03652/06052

[Obstacles to the front and rear of unit]

- The top and both sides must remain open. Either the obstacle to the front or the obstacle to the rear must be no taller than the height of the outdoor unit.

(1) Single-unit installation

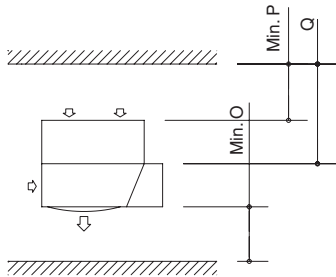

Dimension Q

If a snow protection duct is attached after the unit is installed, verify that dimension Q is 19-11/16 in. or more.

Outdoor unit	O	P
CHX03652/06052	39-3/8	5-29/32

(2) Obstacles on both sides

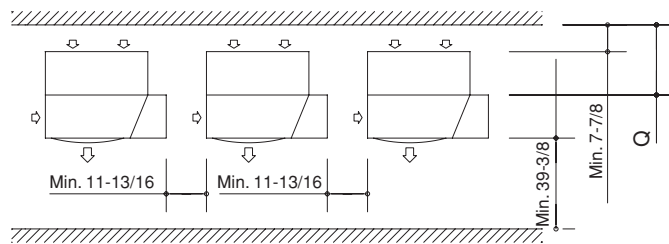

[Installation in front-rear rows]

- The top and both sides must remain open. Either the obstacle to the front or the obstacle to the rear must be no taller than the height of the outdoor unit.

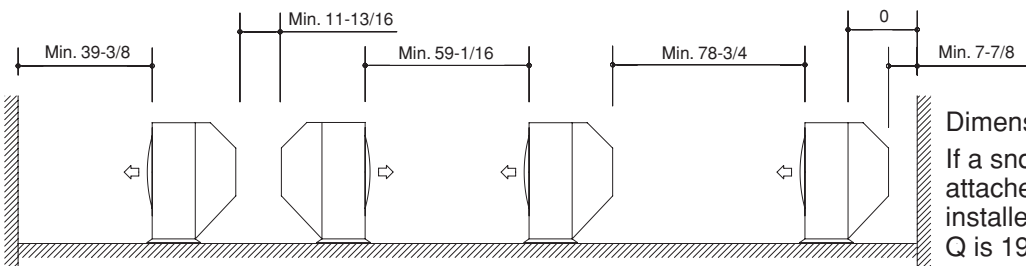

Dimension Q

If a snow protection duct is attached after the unit is installed, verify that dimension Q is 19-11/16 in. or more.

Unit: in.

3. HOW TO INSTALL THE INDOOR UNIT

■ 4-Way Air Discharge Semi-Concealed Type (X Type)

3-1. Preparation for Suspending

This unit uses a drain pump. Use a carpenter's level to check that the unit is level.

3-2. Suspending the Indoor Unit

- Fix the suspension bolts securely in the ceiling using the method shown in the diagrams (Figs. 3-1 and 3-2), by attaching them to the ceiling support structure, or by any other method that ensures that the unit will be securely and safely suspended.
- Follow Fig. 3-2 and Table 3-1 to make the holes in the ceiling.

Note: For DC Fan Tap Change Procedure for 4-Way Cassette, see page 31.

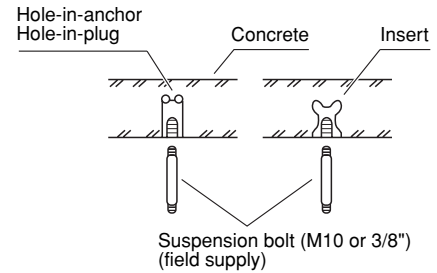

Fig. 3-1

Table 3-1 Unit: in. (mm)

Type	Length	A	B	C	D
12, 18, 24, 36		31-1/32 (788)	28-15/32 (723)	34-27/32 (885)	34-27/32 (885)

- Determine the pitch of the suspension bolts using the supplied full-scale installation diagram. The diagram and table (Fig. 3-3 and Table 3-2) show the relationship between the positions of the suspension fitting, unit, and panel.

Table 3-2 Unit: in. (mm)

Type	Length	A	B	C	D	E
12, 18, 24		4-29/64 (113)	6-13/16 (173)	10-5/64 (256)	8-17/64 (210)	3-15/32 (88)
36		4-29/64 (113)	6-13/16 (173)	12-9/16 (319)	8-17/64 (210)	3-15/32 (88)

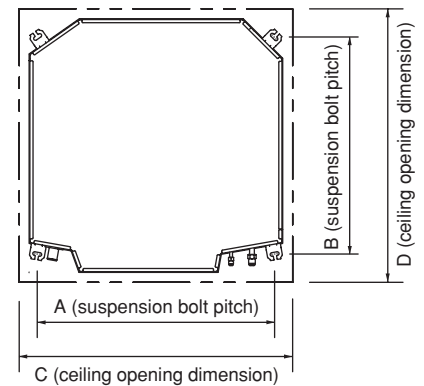

Fig. 3-2

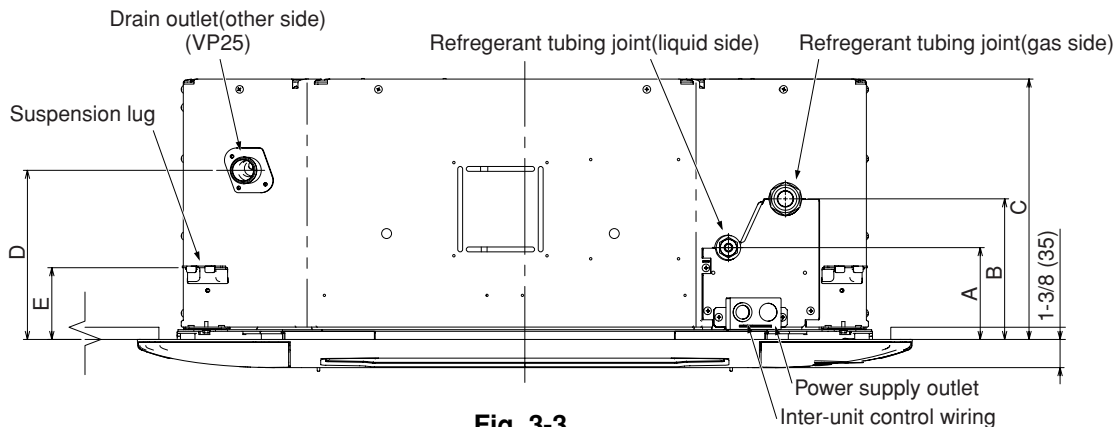

Fig. 3-3

Unit: in. (mm)

3-3. Placing the Unit Inside the Ceiling

- When placing the unit inside the ceiling, determine the pitch of the suspension bolts using the supplied full-scale installation diagram. (Fig. 3-4) Tubing and wiring must be laid inside the ceiling when suspending the unit. If the ceiling is already constructed, lay the tubing and wiring into position for connection to the unit before placing the unit inside the ceiling.

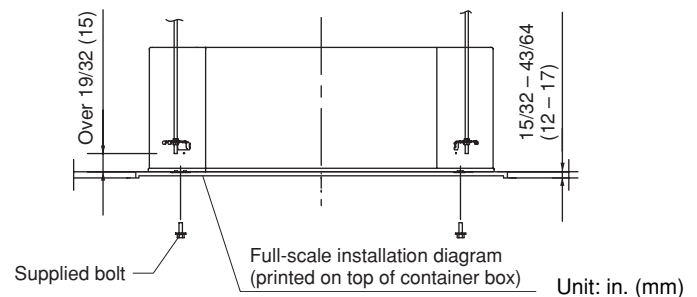

Fig. 3-4

Unit: in. (mm)

- (2) The length of suspension bolts must be appropriate for a distance between the bottom of the bolt and the bottom of the unit of more than $19/32$ in. as shown in Fig. 3-5.
- (3) Thread the 3 hexagonal nuts and 2 washers (field supply) onto each of the 4 suspension bolts as shown in Fig. 3-5. Use 1 nut and 1 washer for the upper side, and 2 nuts and 1 washer for the lower side, so that the unit will not fall off the suspension lugs.
- (4) Adjust so that the distance between the unit and the ceiling bottom is $15/32$ to $43/64$ in. Tighten the nuts on the upper side and lower side of the suspension lug.
- (5) Remove the protective polyethylene used to protect the fan parts during transport.

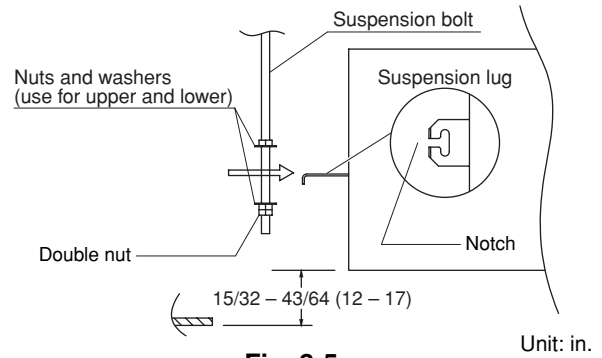

Fig. 3-5

3-4. Installing the Drain Piping

- (1) Prepare a standard hard PVC pipe (O.D. 1-1/4 in.) for the drain and use the supplied drain hose and hose band to prevent water leaks. The PVC pipe must be purchased separately. The unit's transparent drain port allows you to check drainage. (Fig. 3-6)



CAUTION

- Insert the drain pipe until it contacts the socket, as shown in Fig. 3-6, then secure it tightly with the hose band.
- Do not use adhesive when connecting the supplied hose.

Reasons: 1. It may cause water to leak from the connection. Since the connection is slippery just after the adhesive has been applied, the pipe easily slips off.
2. The pipe cannot be removed when maintenance is needed.

- Do not bend the supplied drain hose 90° or more. The hose may slip off.
- Align the hose bands with the end of the hose. Tighten the hose band firmly. Please make sure that the bead is not covered by the hose band. (Fig. 3-6)



CAUTION

Tighten the hose clamps so their locking nuts face upward. (Fig. 3-6)

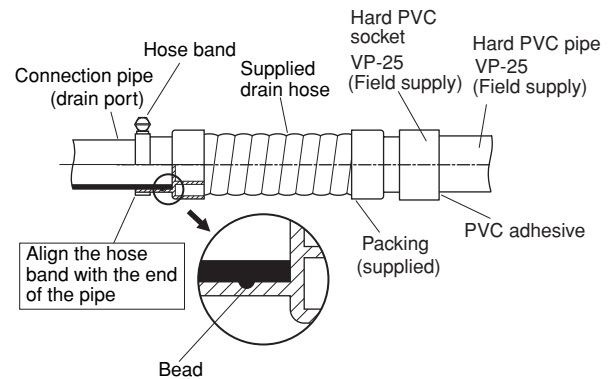

Fig. 3-6

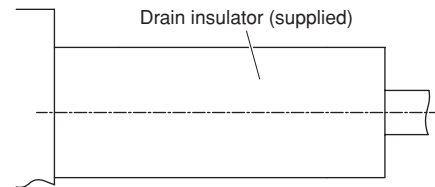

Fig. 3-7

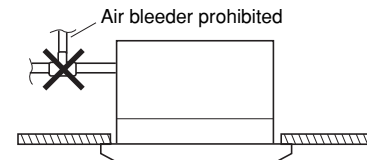

Fig. 3-8

- (2) After checking the drainage, wrap the supplied packing and drain pipe insulator around the pipe. (Fig. 3-7)

NOTE

Make sure the drain pipe has a downward gradient (1/100 or more) and that there are no water traps.



CAUTION

- Do not install an air bleeder as this may cause water to spray from the drain pipe outlet. (Fig. 3-8)



CAUTION

- In cases where it is necessary to raise the height of the drain piping, the drain piping can be raised to a maximum height of 33-15/32" above the bottom surface of the ceiling. Under no conditions attempt to raise it higher than 33-15/32" above the bottom surface of the ceiling. Doing so will result in water leakage. (Fig. 3-9)
- Do not install the pipe with an upward gradient from the connection port. This will cause the drain water to flow backward and leak when the unit is not operating. (Fig. 3-10)
- Do not apply force to the piping on the unit side when connecting the drain pipe. The pipe should not be allowed to hang unsupported from its connection to the unit. Fasten the pipe to a wall, frame, or other support as close to the unit as possible. (Fig. 3-11)
- Provide insulation for any pipes that are run indoors.

3-5. Checking the Drainage

After wiring and drain piping are completed, use the following procedure to check that the water will drain smoothly. For this, prepare a bucket and wiping cloth to catch and wipe up spilled water.

- (1) Connect power to the power terminal board (R, S terminals) inside the electrical component box.
- (2) Slowly pour about 0.3 gal of water into the drain pan to check drainage. (Fig. 3-12)
- (3) Short the check pin (CHK) on the indoor control board and operate the drain pump. Check the water flow through the transparent drain pipe and see if there is any leakage.
- (4) When the check of drainage is complete, open the check pin (CHK) and remount the tube cover.

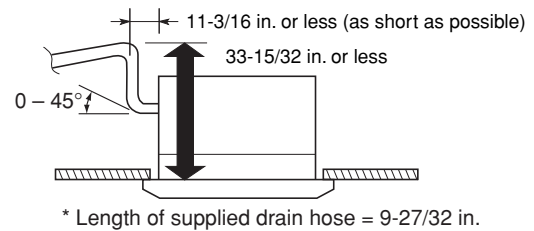

Fig. 3-9

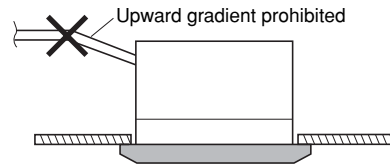

Fig. 3-10

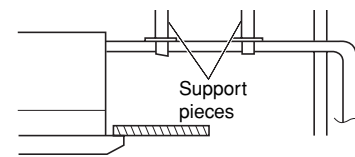

Fig. 3-11

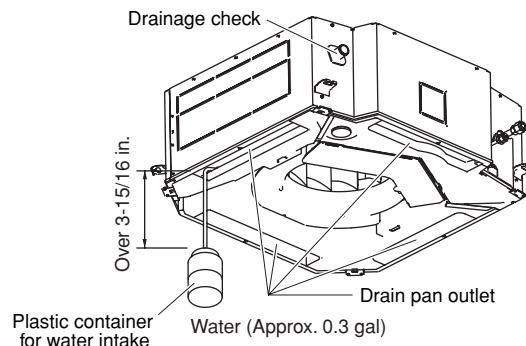

Fig. 3-12



CAUTION

Be careful since the fan will start when you short the pin on the indoor control board.



3-6. How to Install the Ceiling Panel

3-6-1. Before Installing the Ceiling Panel

Checking the unit position

- (1) Check that the ceiling hole is within this range:
 $33\text{-}55/64 \times 33\text{-}55/64$ to $35\text{-}53/64 \times 35\text{-}53/64$ in.
- (2) Use the full-scale installation diagram (from the packaging) that was supplied with the unit to determine the positioning of the unit on the ceiling surface. If the positions of the ceiling surface and unit do not match, air leakage, water leakage, flap operation failure, or other problems may result.



- Never place the panel face-down. Either hang it vertically or place it on top of a projecting object. Placing it face-down will damage the surface.
- Do not touch the flap or apply force to it. (This may cause flap malfunction.)

Remove the air-intake grille and air filter from the ceiling panel. (Figs. 3-16, 3-17 and 3-18)

- a) Remove the 2 screws on the latch of the air-intake grille. (Fig. 3-16)
- b) Slide the air-intake grille catches in the direction shown by the arrows ① to open the grille. (Fig. 3-17)
- c) With the air-intake grille opened, remove the grille hinge from the ceiling panel by sliding it in the direction shown by the arrow ②. (Fig. 3-18)

Removing the corner cover

- a) Slide the corner cover to the direction shown by the arrow ① to remove the corner cover. (Fig. 3-18).

Ⓐ must be within the range of $15/32 - 43/64$ in.
 If not within this range, malfunction or other trouble may result.

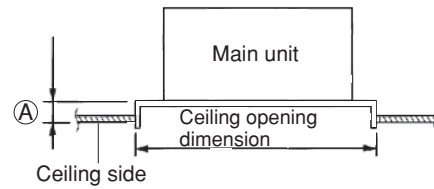

Fig. 3-13

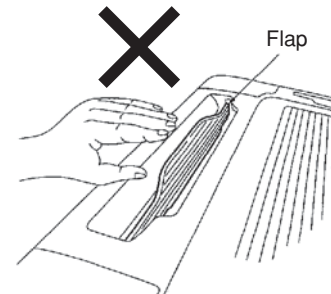

Fig. 3-14

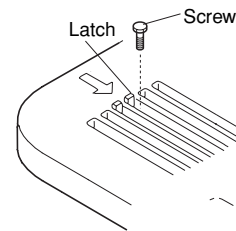

Fig. 3-15

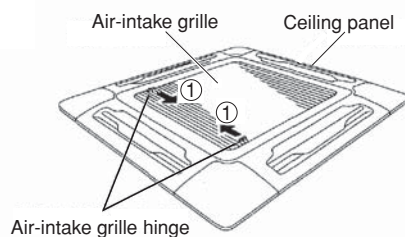

Fig. 3-16



Fig. 3-17

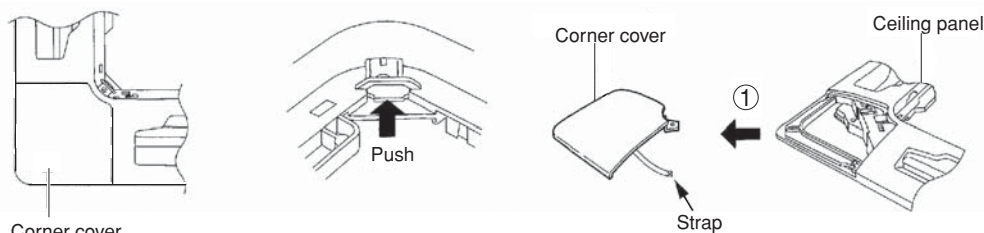

Fig. 3-18

3-6-2. Installing the Ceiling Panel

After completing the wiring process, install the supplied wiring cover before installing the panel. It is not possible to install the wiring cover after installing the panel.

The power must be turned ON in order to change the flap angle. (Do not attempt to move the flap by hand. Doing so may damage the flap.)

(1) Insert the temporary fasteners (stainless steel) on the inside of the ceiling panel into the square holes on the unit to temporarily fasten the ceiling panel in place. (Fig. 3-20-1)

- The ceiling panel must be installed in the correct direction relative to the unit. Align the REF. PIPE and DRAIN marks on the ceiling panel corner with the correct positions on the unit.

- To remove the ceiling panel, support the ceiling panel while pressing the temporary fasteners toward the outside. (Fig. 3-20-1)

(2) Align the panel installation holes and the unit screw holes.

(3) Tighten the supplied washer head screws at the 4 panel installation locations so that the panel is attached tightly to the unit. (Fig. 3-20-2)

(4) Check that the panel is attached tightly to the ceiling.

- At this time, make sure that there are no gaps between the unit and the ceiling panel, or between the ceiling panel and the ceiling surface. (Fig. 3-21)

- If there is a gap between the panel and the ceiling, leave the ceiling panel attached and make fine adjustments to the installation height of the unit to eliminate the gap with the ceiling. (Fig. 3-21)

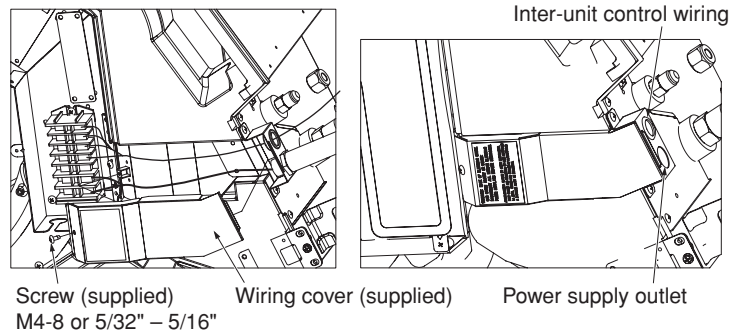

Fig. 3-19-1

Fig. 3-19-2

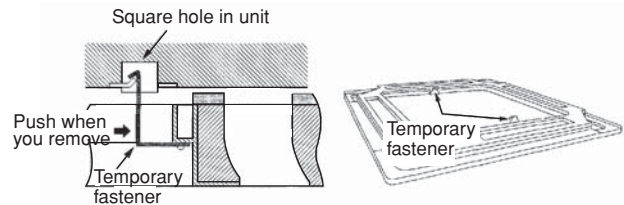

Fig. 3-20-1

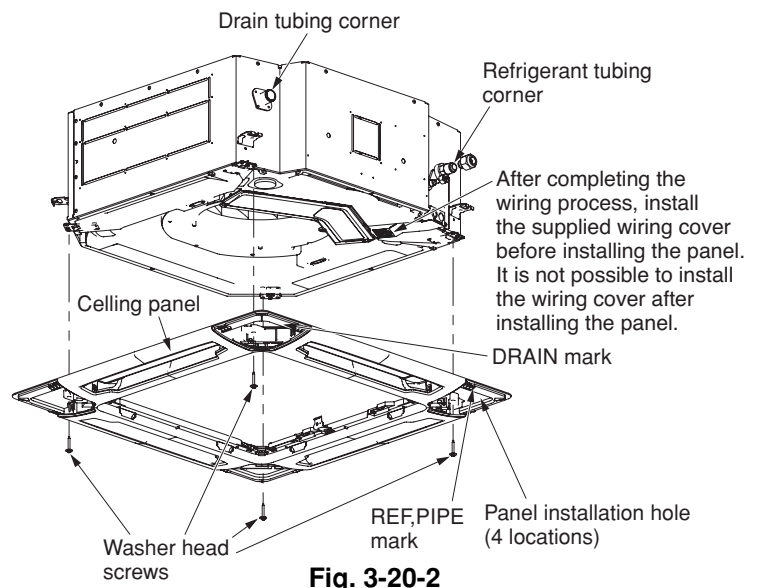

Fig. 3-20-2

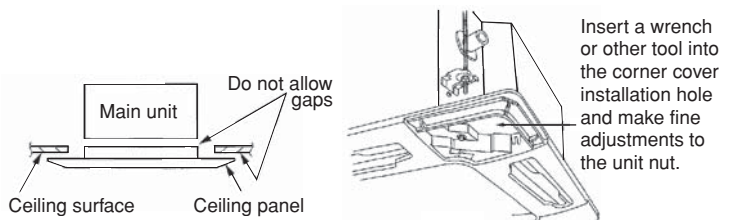

Fig. 3-21

Fig. 3-22



CAUTION

- If the screws are not sufficiently tightened, trouble such as that shown in the figure below may occur. Be sure to tighten the screws securely.

- If a gap remains between the ceiling surface and the ceiling panel even after the screws are tightened, adjust the height of the unit again.

The height of the unit can be adjusted from the ceiling panel corner hole, with the ceiling panel attached, to an extent that does not affect the unit levelness, the drain hose, or other elements.

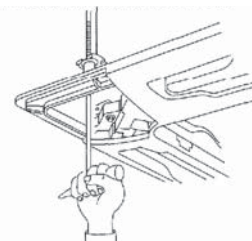
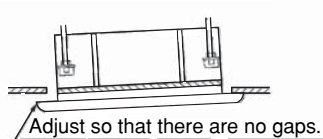
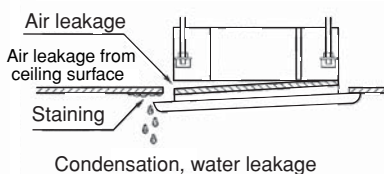

Fig. 3-23

3-6-3. Wiring the Ceiling Panel

- (1) Open the cover of the electrical component box.
 - (2) Connect the 7P wiring connector (red) from the ceiling panel to the connector in the unit electrical component box.
- If the connectors are not connected, the Auto flap will not operate. Be sure to connect them securely.
 - Check that the wiring connector is not caught between the electrical component box and the cover.
 - Check that the wiring connector is not caught between the unit and the ceiling panel.

3-6-4. How to Attach the Corner & Air-Intake Grille

Attaching the corner cover and air-intake grille

A. Attaching the corner cover

- (1) Check that the safety cord from the corner cover is fastened to the ceiling panel pin, as shown in the figure.
- (2) Use the supplied screws to attach the corner cover to the ceiling panel.

B. Attaching the air-intake grille

- To install the air-intake grille, follow the steps for **Removing the grille** in the reverse order. By rotating the air-intake grille, it is possible to attach the grille onto the ceiling panel from any of 4 directions. Coordinate the directions of the air-intake grilles when installing multiple units, and change the directions according to customer requests.
- **When attaching the air-intake grille, be careful that the flap lead wire does not become caught.**
- **Be sure to attach the safety cord that prevents the air-intake grille from dropping off to the ceiling panel unit as shown in the figure at right.**
- With this ceiling panel, the directions of the air-intake grille lattices when installing multiple units, and the position of the label showing the company name on the corner panel, can be changed according to customer requests, as shown in the figure below. However, the optional wireless receiver kit can only be installed at the refrigerant-tubing corner of the ceiling unit.

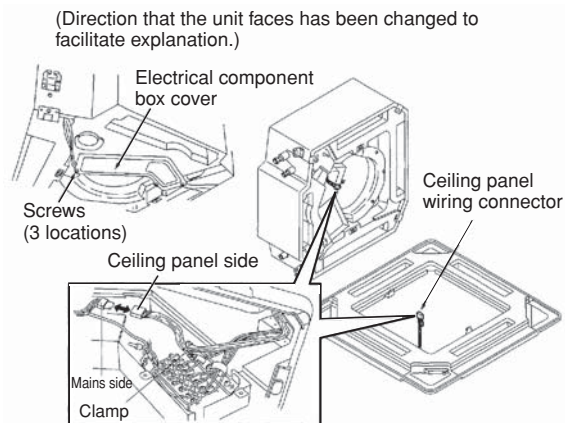

* Pass the wiring connector through the clamp to fasten it in place, as shown in the figure.

Fig. 3-24

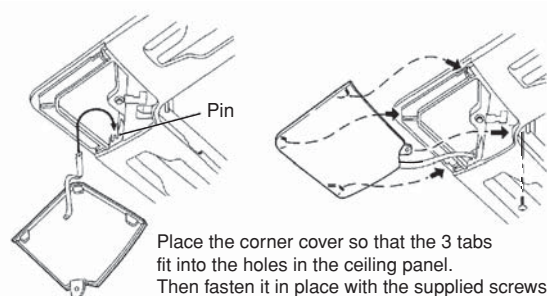

Fig. 3-25

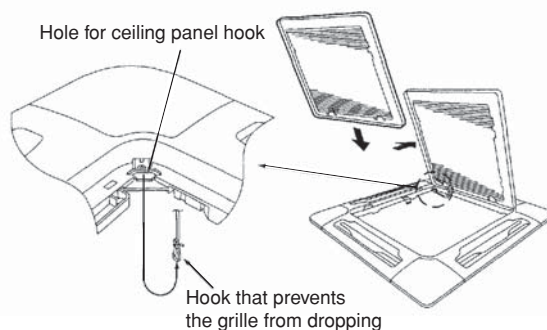

Fig. 3-26

Locations of the air-intake grille catches at the time the product is shipped.

* The grille can be installed with these catches facing in any of 4 directions.

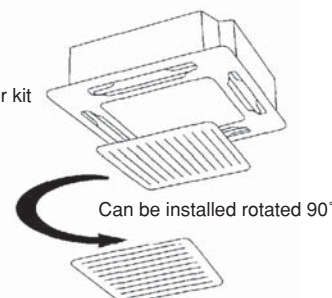
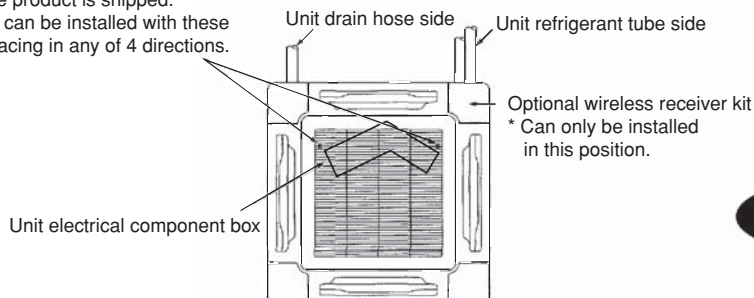

Fig. 3-27



3-6-5. Checking After Installation

- Check that there are no gaps between the unit and the ceiling panel, or between the ceiling panel and the ceiling surface. Gaps may cause water leakage and condensation.
- Check that the wiring is securely connected.
If it is not securely connected, the auto flap will not operate. ("P09" is displayed on the remote controller.) In addition, water leakage and condensation may occur.

3-6-6. When Removing the Ceiling Panel for Servicing

When removing the ceiling panel for servicing, remove the air-intake grille and air filter, disconnect the wiring connector inside the electrical component box, and then remove the 4 mounting screws.

3-6-7. Adjusting the Auto Flap

The air-direction louver on the ceiling panel outlet can be adjusted as follows.

- Adjust the louver to the desired angle using the remote controller. The louver also has an automatic air-sweeping mechanism.

NOTE

- Never attempt to move the louver by hand.
- Proper air flow depends on the location of the air conditioner, the layout of the room and furniture, etc. If cooling or heating seems inadequate, try changing the direction of the air flow.

3-7. Special Remarks

DC Fan Tap Change Procedure

<Steps> Be sure to turn OFF the power (at mains) before beginning the work below.

- (1) In the table below, check the field-supply parts that will be used. (If this setting is not made, the airflow may decrease and condensation may occur.)

Setting	
(a)	Air shield material (for use with 3-direction discharge)*
	Air shield material (for use when a discharge duct is connected)*
(b)	Air shield material (for use with 2-direction discharge)*

* Use field-supply air shield material.

- Setting (a): Go to (2).
Setting (b): Go to (3).

- (2) Setting (a)
Open the cover of the electrical component box.
Short the short-circuit pin TP3 (2P, yellow) on the indoor unit control PCB.
- (3) Setting (b)
Open the cover of the electrical component box.
Short the short-circuit pin TP6 (2P, white) on the indoor unit control PCB.

Indoor unit control PCB

* PCB model No.: CR-SXRP56B-B

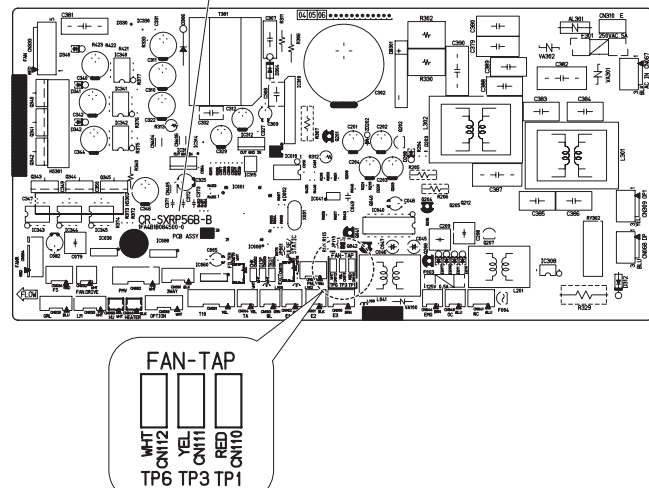

Fig. 3-28

■ 1-Way Air Discharge Semi-Concealed Type (A Type)

3-8. Suspending the Indoor Unit

- (1) Follow the diagrams to make the holes in the ceiling.
(Figs. 3-29 and 3-30)
- (2) Depending on the ceiling type:
 - Insert suspension bolts as shown in Fig. 3-31
 - or
 - Use existing ceiling supports or construct a suitable support as shown in Fig. 3-32.
 - Make sure that the length of suspension bolts from the bottom of the unit is 19/32 in. or more. (Fig. 3-33)

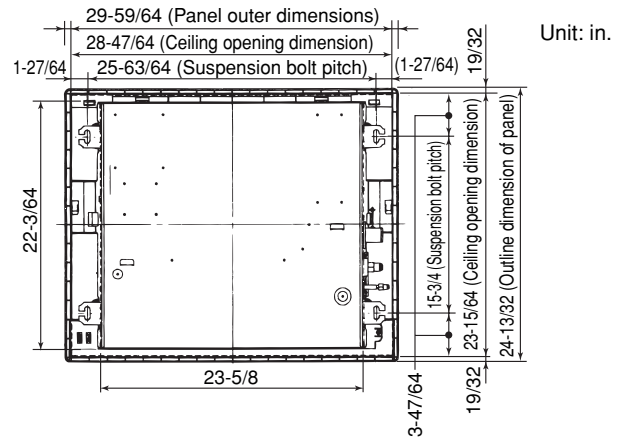

Fig. 3-29



WARNING

It is important that you use extreme care in supporting the indoor unit from the ceiling. Ensure that the ceiling is strong enough to support the weight of the unit. Before hanging the unit, test the strength of each attached suspension bolt.

- (3) Calculate the suspension bolt pitch using the full-size installation diagram (printed on the package). The relationship between the positions of the suspension lugs, unit, and ceiling panel is as shown in Fig. 3-30.

- (4) Cut the ceiling material, if necessary.
(Figs. 3-29 and 3-30)

If the system requires fresh air to be drawn into the unit, cut and remove the insulation (both externally and internally) at the location shown as (A) in Figs. 3-34 and 3-35.

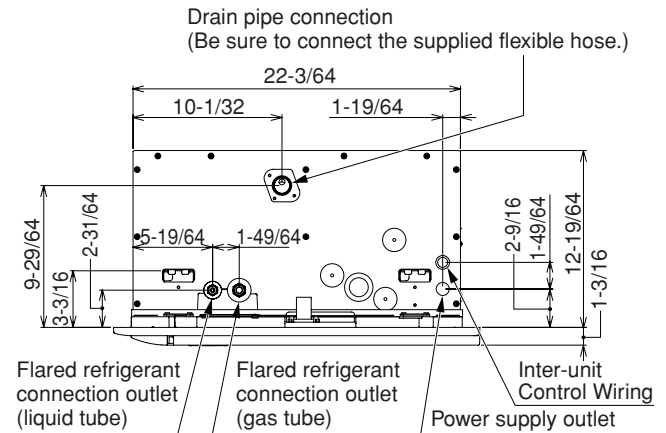

Fig. 3-30

Unit: in.



CAUTION

When making the cuts to the insulation, be careful not to damage the drain pan.

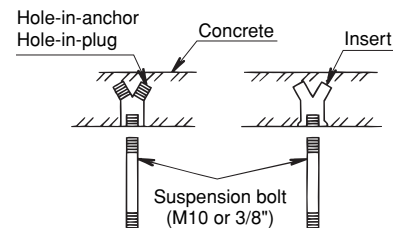

Fig. 3-31

3-9. Placing the Unit Inside the Ceiling



CAUTION

Be sure to use a level gauge and confirm that the unit is level. If it is not level, water leakage may occur.

- (1) Use the supplied M5 or 3/16" screws (4) to attach the full-size installation diagram to the indoor unit suspension lugs, in order to obtain the ceiling opening dimensions for suspending the unit.

Caution: Piping and wiring work must be performed inside the ceiling after the unit is suspended. Therefore if the ceiling is already installed, the wiring and piping work should be completed up to the connection points prior to suspending the unit.

- (2) Attach the special washers (supplied) and nuts (field supply) to the suspension bolts (4 locations).



CAUTION

- Use M10 or 3/8" nuts.
- The length of the suspension bolts must be such that there is a space of at least 19/32 in. below the bottom of the suspension lugs, as shown in Fig. 3-33. If the length of the suspension bolts is too long, the bolts may interfere with the ceiling panel and louver motor, preventing their installation.

- (3) Thread the 3 hexagonal nuts and 2 washers (field supply) onto each of the 4 suspension bolts as shown in Fig. 3-36. Use 1 nut and 1 washer for the upper side, and 2 nuts and 1 washer for the lower side, so that the unit will not fall off the suspension lugs.

- (4) Lift up the indoor unit and fit the suspension bolts into the notches in the suspension lugs.

- (5) Adjust so that the distance between the bottom of the indoor unit suspension lugs and the bottom of the ceiling panel is 25/32 – 1 in. Then tighten the nuts above and below each suspension lug. The full-size installation diagram can be used to help adjust the height of the indoor unit.

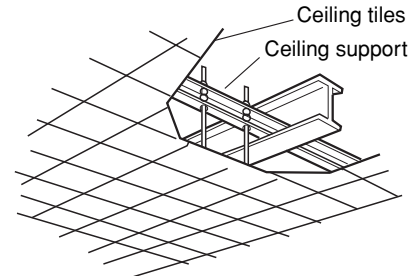

Fig. 3-32

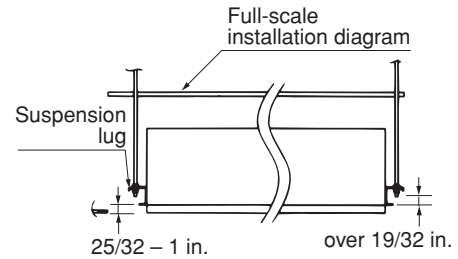
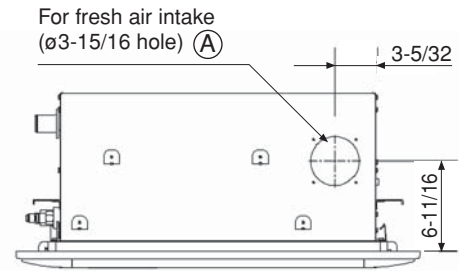
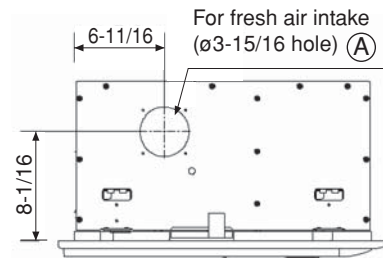

Fig. 3-33



Unit: in.

Fig. 3-34



Unit: in.

Fig. 3-35

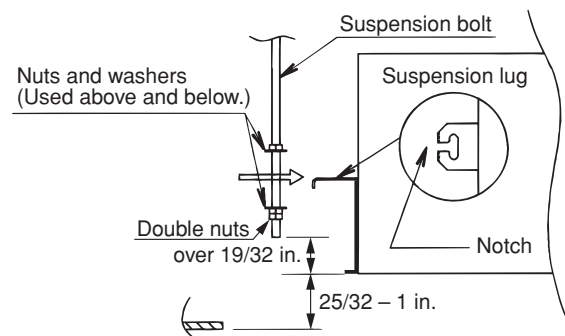

Fig. 3-36

A



CAUTION

- The indoor unit includes a drain pump. Be sure to use a level gauge and verify that the unit is level.
- Before inserting the ceiling material, complete as much of the drain piping work and refrigerant tubing work as possible.

(6) The distance between the unit and the opening of the ceiling and the distance between the bottom surface of the ceiling and the bottom surface of the flange of the unit should follow the dimensions given in Figs. 3-37 and 3-38.

3-10. Installing the Drain Piping

(1) Prepare standard hard PVC pipe (O.D. 1-1/4") for the drain and use the supplied drain hose and hose band to prevent water leaks.

The PVC pipe must be purchased separately. The unit's transparent drain port allows you to check drainage. (Fig. 3-39)



CAUTION

- Do not use adhesive at the drain connection port on the indoor unit.
- Insert the drain pipe until it contacts the socket, as shown in the figure at right, then secure it tightly with the hose band.
- Tighten the hose clamps so their locking nuts face upward. (Fig. 3-39)
- Do not use the supplied drain hose bent at a 90° angle. (The maximum permissible bend is 45°.)
- Check the drainage at the unit drain port (transparent).

(2) After checking the drainage, wrap the supplied packing and drain pipe insulator around the pipe, then secure it with the supplied clamps. (Fig. 3-40)

NOTE

Make sure the drain pipe has a downward gradient (1/100 or more) and that there are no water traps.

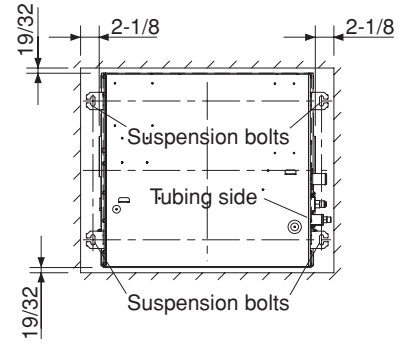

Fig. 3-37

Unit: in.

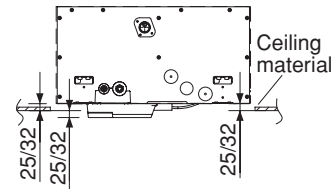

Fig. 3-38

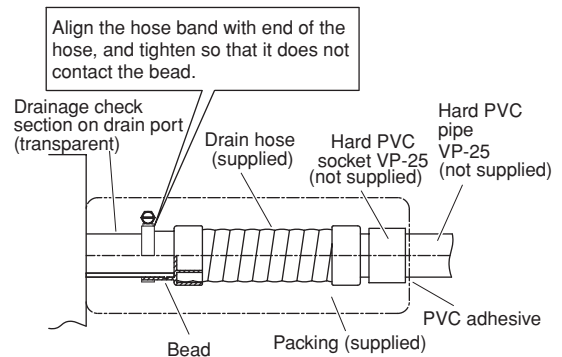

Fig. 3-39

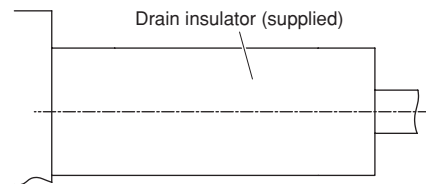

Fig. 3-40



CAUTION

- Do not install an air bleeder as this may cause water to spray from the drain pipe outlet. (Fig. 3-41)
- In cases where it is necessary to raise the height of the drain piping, the drain piping can be raised to a maximum height of 33-15/32" above the bottom surface of the ceiling. Under no conditions attempt to raise it higher than 33-15/32" above the bottom surface of the ceiling. Doing so will result in water leakage. (Fig. 3-42)
- Do not use natural drainage.
- Do not install the pipe with an upward gradient from the connection port. This will cause the drain water to flow backward and leak when the unit is not operating. (Fig. 3-43)
- Do not apply force to the piping on the unit side when connecting the drain pipe. The pipe should not be allowed to hang unsupported from its connection to the unit. Fasten the pipe to a wall, frame, or other support as close to the unit as possible. (Fig. 3-44)
- Provide insulation for any pipes that are run indoors.

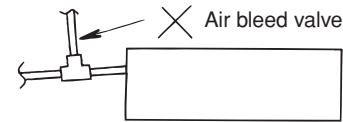

Fig. 3-41

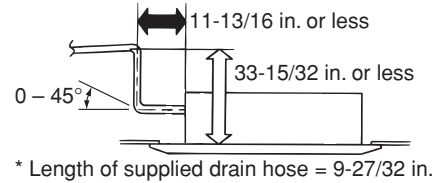

Fig. 3-42

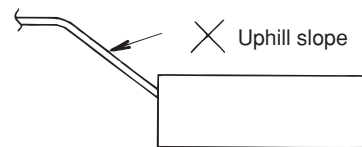

Fig. 3-43

3-11. Checking the Drainage

After wiring and drain piping are completed, use the following procedure to check that the water will drain smoothly. For this, prepare a bucket and wiping cloth to catch and wipe up spilled water.

- (1) Connect power to the power terminal board (R, S terminals) inside the electrical component box.
- (2) Pour about 0.2 gal of water into the drain pan using a siphon pump through the air outlet grille. (Fig. 3-45)
- (3) Short the check pin (CHK) on the indoor control board and operate the drain pump. Check the water flow through the transparent drain pipe and see if there is any leakage.

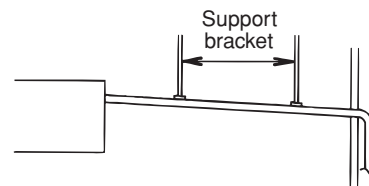

Fig. 3-44

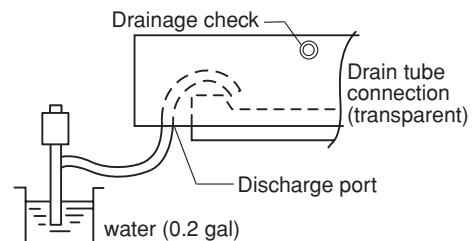

Fig. 3-45



CAUTION

Be careful since the fan will start when you short the pin on the indoor control board.

- (4) When the drainage check is complete, open the check pin (CHK) and remount the insulator.



CAUTION

The bottom drain port is for use only during test runs and servicing inspections. Do not connect the drain pipe to the bottom drain port.

3-12. Electrical Power Wiring

(1) Wiring connections

The power inlet is on the side of the indoor unit where the refrigerant tubing is located. The electrical component box is on the lower air intake surface of the indoor unit.

(Fig. 3-46)

(2) Wiring

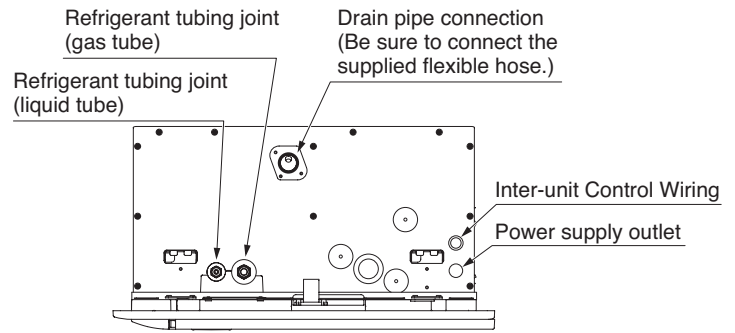

Fig. 3-46

- Route the power wiring into the indoor unit through the power inlet on the side of the unit. At this time, be sure that the wiring passes through the power inlet in the unit power section. If the wiring does not pass through this inlet, it may become pinched by the ceiling panel, and may result in fire.
- Pass the wiring through the power inlet on the electrical component box and connect it to the terminal plate. Then fasten the wiring in place with the clamp.

3-13. How to Install the Ceiling Panel

Component Parts

Part name	Quantity	Appearance	Part name	Quantity	Appearance
Ceiling panel	1		Washer-head screw	4	M5 × 40 or 5/16" × 9/16"
			Screw	2	4 × 12 or 5/32" × 15/32" For fastening side panel

3-13-1. Before Installing the Ceiling Panel

Checking the position of the indoor unit

- (1) Check that the dimensions of the ceiling opening are the following:

28-47/64" × 23-17/64"

* For details, refer to the installation manual that was supplied with the indoor unit.

- (2) Check that the positions of the ceiling surface and indoor unit are as shown in Fig. 3-47. If the positions of the ceiling surface and indoor unit are not correct, problems such as air leakage, water leakage, and flap operation trouble may occur.

- Do not rest the panel facing downwards, lean up against a wall, or leave it sitting on top of a protruding object. Doing so may scratch the panel surface.
- Do not apply excessive force to the flap. (Doing so may damage the flap.)

Be sure that this distance is within the range of 25/32 – 1 in. If it is not within this range, malfunction or other problems may result.

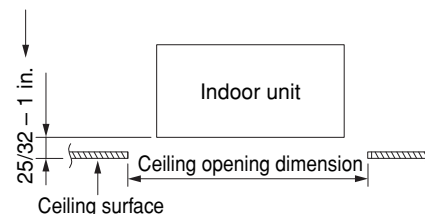

Fig. 3-47

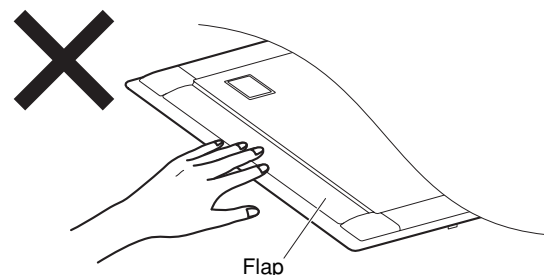
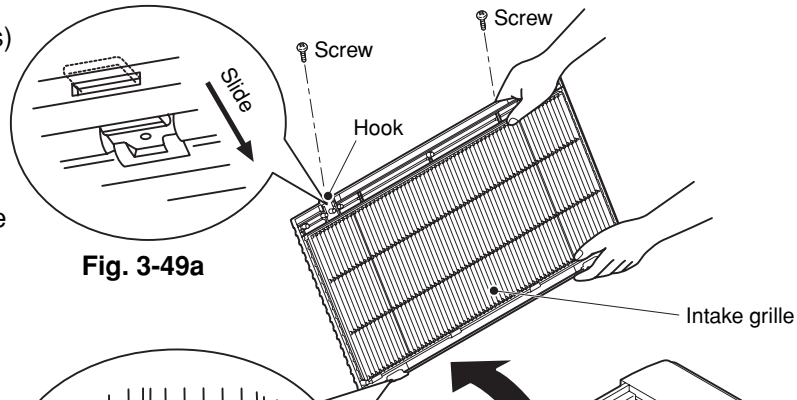

Fig. 3-48

Removing the intake grille

Slide the intake grille hooks (2 locations) in the direction of the arrow to open the intake grille. (fig. 3-49a)

When the intake grille is open, press a flathead screwdriver against the rear tabs (2 locations) and pull out the intake grille. (Fig. 3-49b)



Removing the side panel

Grasp the finger grip on the side panel and slide the panel in the direction of arrow ① to remove the panel.

(There are 2 panels: 1 each on the left and right sides.) (Fig. 3-51)

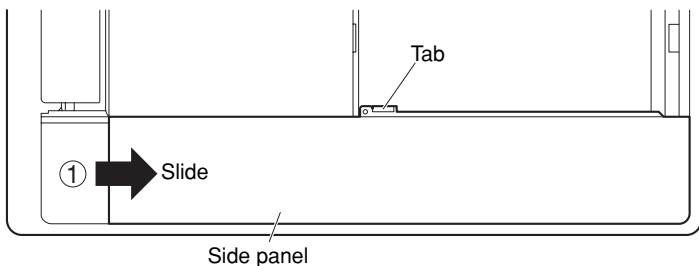

Press on the tabs with a flathead (minus) screwdriver while pulling out the intake grille.

3-13-2. Installing the ceiling panel

(1) Fasten the hooks on both sides of the ceiling panel to the indoor unit. The hooks on one side (2 locations) are stationary, while the hook on the other side is moveable. (Fig. 3-52)

(2) Angle the panel somewhat and fasten the stationary hook into the fastener on the side of the unit.

(3) After verifying that the hook is fastened, press the other end up until the ceiling panel is level. Then press upwards until the moveable hook is fastened into the fastener on the unit.

(4) Verify that the hooks on both sides of the ceiling panel are securely fastened to the unit. If the hooks are not securely fastened, the panel may fall. At this point, the panel is now provisionally fastened to the unit.

● When removing the panel, press the movable hook toward the inside while supporting the panel. (Fig. 3-53)

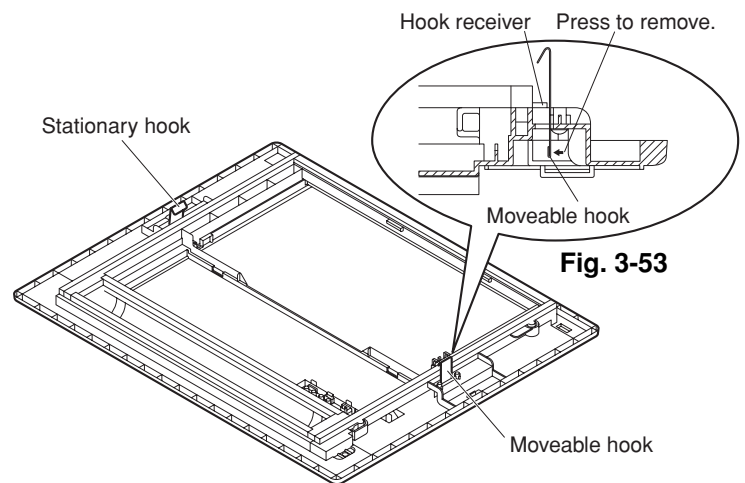

- (5) Align the installation holes on the panel with the bolt holes on the unit.
- (6) Insert the supplied washer head bolts into the 4 panel installation holes, and tighten until the panel is securely fastened against the unit. (Fig. 3-54)
- (7) Verify that the panel is securely fastened against the unit.

- At this time, make sure that there is no gap between the indoor unit and the ceiling panel, or between the ceiling panel and the ceiling surface. (Fig. 3-55)
- If there is a gap between the ceiling panel and the ceiling, leave the panel attached and adjust the installation height of the indoor unit upwards until the gap with the ceiling is eliminated. (Fig. 3-56)
- If the adjustment is small enough that it will not affect the levelness of the indoor unit or the drain piping, then the unit height can be adjusted from the side panel installation holes, with the ceiling panel still attached.

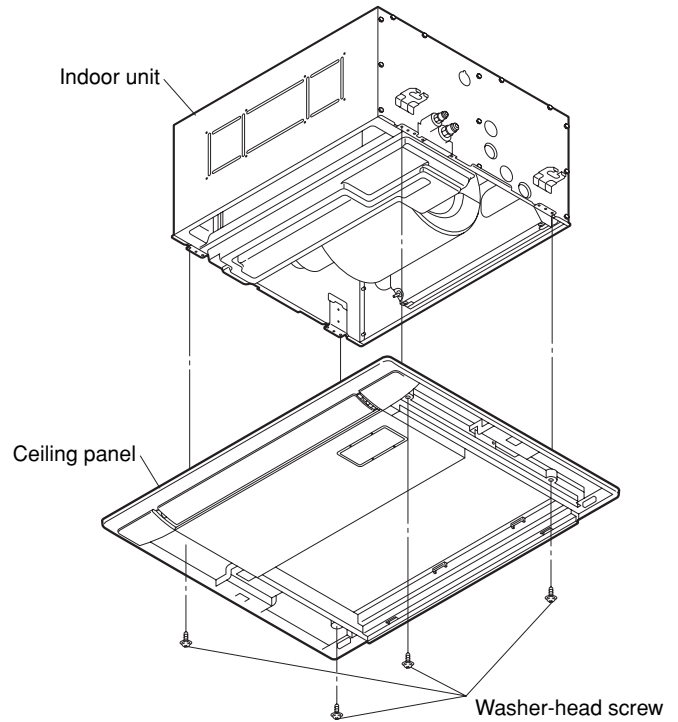

Fig. 3-54

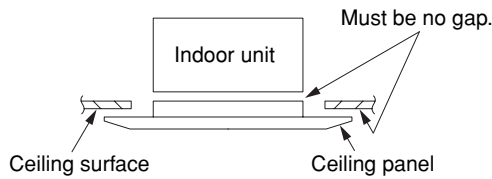

Fig. 3-55

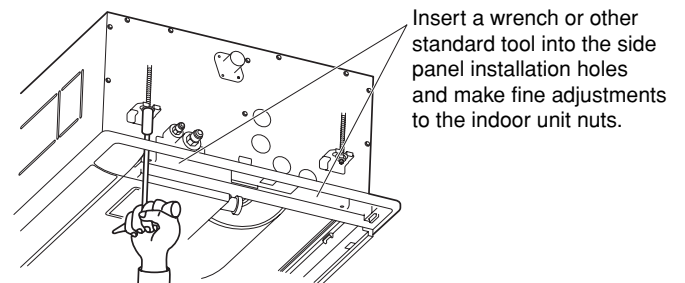
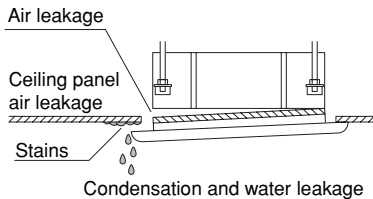

Fig. 3-56



CAUTION

- If the screws are not fully tightened, problems such as those shown below may occur. Be sure to tighten the screws securely.



- If there is a gap between the ceiling surface and the ceiling panel even when the screws are fully tightened, readjust the height of the indoor unit. (Fig. 3-56)

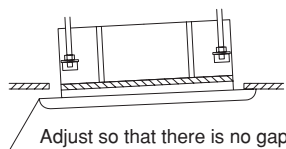

3-13-3. Wiring the ceiling panel

- (1) Loosen the 2 screws on the electrical component box lid, and remove the lid. (Fig. 3-57)
 - (2) Fasten the wiring connector (7P, red) which comes out from the ceiling panel using the lead wire clamps (2 locations) on the unit. Then connect it to the connector (7P, red) inside the indoor unit electrical component box. (Fig. 3-58)
- If the connector is not connected, "P09" is displayed on the remote controller, and the automatic flap will not operate. Be sure to securely connect the connector.
 - Check that the wiring connector is not pinched between the electrical component box and the lid.
 - Check that the wiring connector is not pinched between the indoor unit and the ceiling panel.

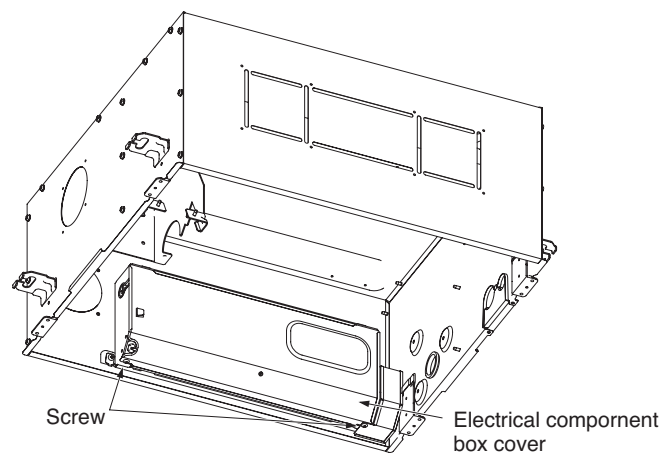

Fig. 3-57

3-13-4. Installing the side panel and intake grille

A. Installing the side panel

- (1) Grasp the side panel finger grip and slide the panel in the direction of the arrow to install the side panel. (Fig. 3-59)
- (2) Fasten the side panel onto the ceiling panel using the supplied screws (4×12 or $5/32" \times 15/32"$).

B. Installing the intake grille

- To install the intake grille, follow the procedure for removing it in the reverse order. (Fig. 3-60)
- When installing the intake grille, be careful that the flap lead wire does not become pinched. (Fig. 3-60)

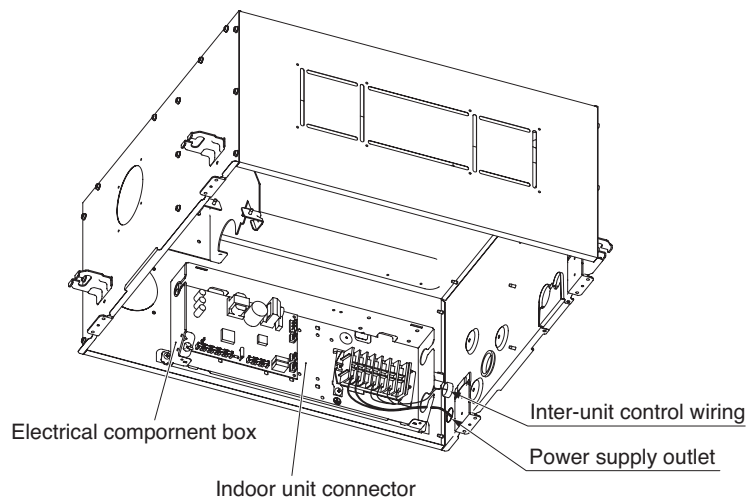

Fig. 3-58

3-13-5. Other

A. Check after installation

- Check again that there is no gap between the indoor unit and the ceiling panel, or between the ceiling panel and the ceiling surface.
 - * If there is a gap, then water leakage and condensation may occur.
- Check that the wiring connections are secure.
 - * If the wiring is not connected, the automatic flap will not operate. ("P09" is displayed on the remote controller.) In addition, water leakage, condensation, and other problems may occur.

B. If a wireless remote controller is used

- For details concerning the installation procedure, refer to the installation manual which was supplied with the optional wireless remote controller and indoor unit internal receiver.

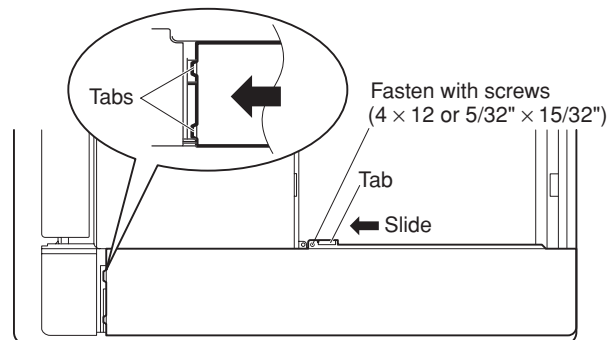

Slide the side panel so that the side panel tabs are fastened to the ceiling panel. Then fasten in place with the supplied screws (4×12 or $5/32" \times 15/32"$).

Fig. 3-59

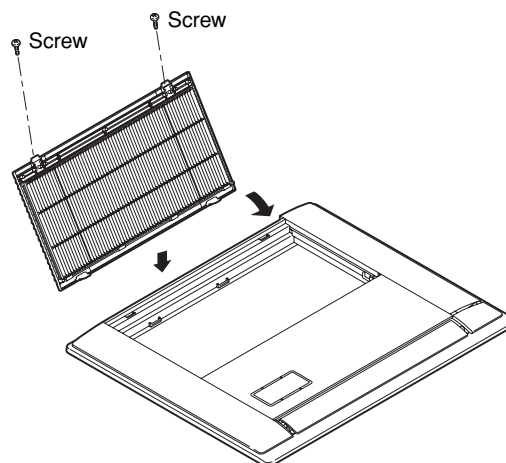

Fig. 3-60

■ Concealed Duct Type (U Type)

3-14. Required Minimum Space for Installation and Service

- This air conditioner is usually installed above the ceiling so that the indoor unit and ducts are not visible. Only the air intake and air outlet ports are visible from below.
- The minimum space for installation and service is shown in Fig. 3-61 and Table 3-3.
- It is recommended that space is provided (17-23/32 × 17-23/32 in.) for checking and servicing the electrical system.
- Fig. 3-62 and Table 3-4 show the detailed dimensions of the indoor unit.

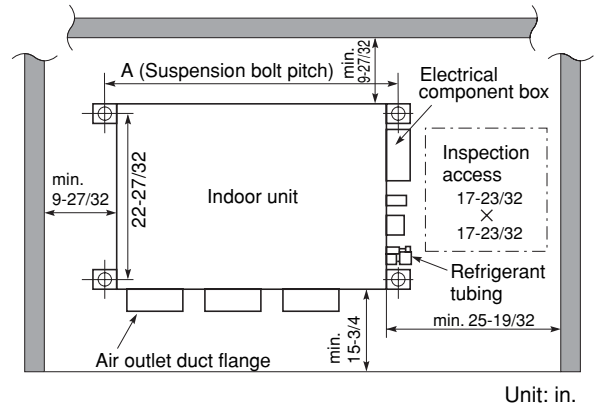

Fig. 3-61

Unit: in.

Table 3-3

Unit: in. (mm)

Type	7, 12, 18	24	36
A (Length)	30-23/32 (780)	42-17/32 (1,080)	61-13/32 (1,560)
Number of duct flanges	2	3	4

Table 3-4

Unit: in.

Dimension Type	A	B	C	D	E	F	G	H	I	J	K	No. of holes	
												L	M
7, 12, 18	26-1/16	23-5/8 (7-7/8 × 3)	27-9/16	30-23/32	11-13/32	10-5/16	26-25/32	28-5/32	7-3/32	—	13-3/8	8	12
24	37-7/8	35-7/16 (7-3/32 × 5)	39-3/8	42-17/32	11-13/32	10-23/32	38-19/32	39-31/32	5-1/8	9-21/32 (9-21/32 × 1)	9-27/32	12	16
36	56-25/32	54-11/32 (9-1/16 × 6)	58-9/32	61-13/32	13-3/16	12-7/32	57-15/32	58-27/32	5-1/8	19-9/32 (9-21/32 × 2)	9-7/16	16	18

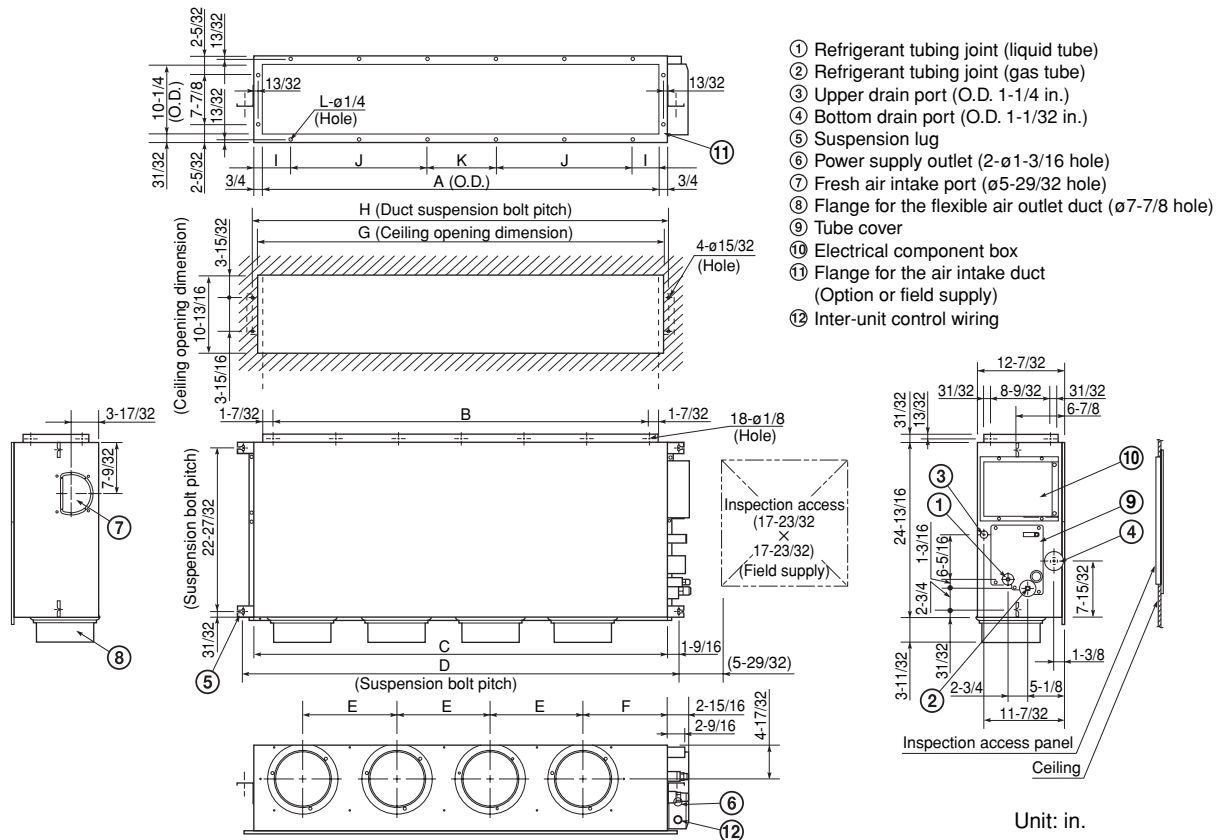

Fig. 3-62

Unit: in.

3-15. Suspending the Indoor Unit

Depending on the ceiling type:

- Insert suspension bolts as shown in Fig. 3-63
- or
- Use existing ceiling supports or construct a suitable support as shown in Fig. 3-64.



WARNING

It is important that you use extreme care in supporting the indoor unit inside the ceiling. Ensure that the ceiling is strong enough to support the weight of the unit. Before hanging the unit, test the strength of each attached suspension bolt.

- (1) When placing the unit inside the ceiling, determine the pitch of the suspension bolts referring to the dimensional data on the previous page. (Fig. 3-61 and Table 3-3)
Tubing must be laid and connected inside the ceiling when suspending the unit. If the ceiling is already constructed, lay the tubing into position for connection to the unit before placing the unit inside the ceiling.
- (2) Screw in the suspension bolts allowing them to protrude from the ceiling as shown in Fig. 3-63. (Cut the ceiling material, if necessary.)
- (3) Thread the 3 hexagonal nuts and 2 washers (field supply) onto each of the 4 suspension bolts as shown in Figs. 3-65 and 3-66. Use 1 nut and 1 washer for the upper part, and 2 nuts and 1 washer for the lower part, so that the unit will not fall off the suspension lugs.

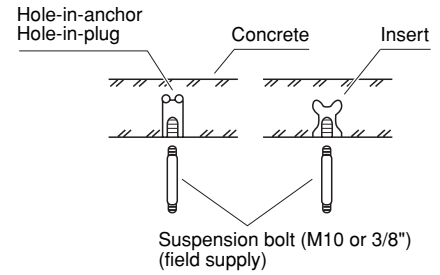

Fig. 3-63

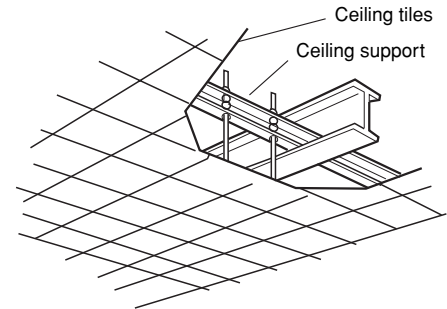

Fig. 3-64

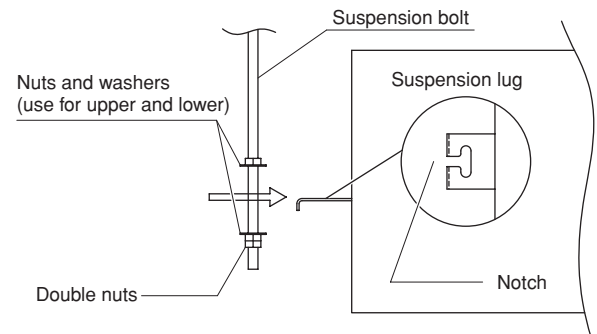

Fig. 3-65

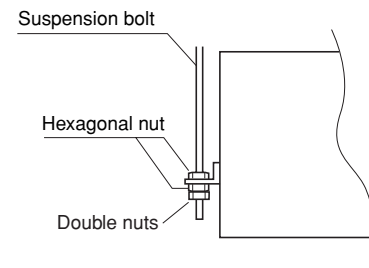

Fig. 3-66

- Fig. 3-67 shows an example of installation.

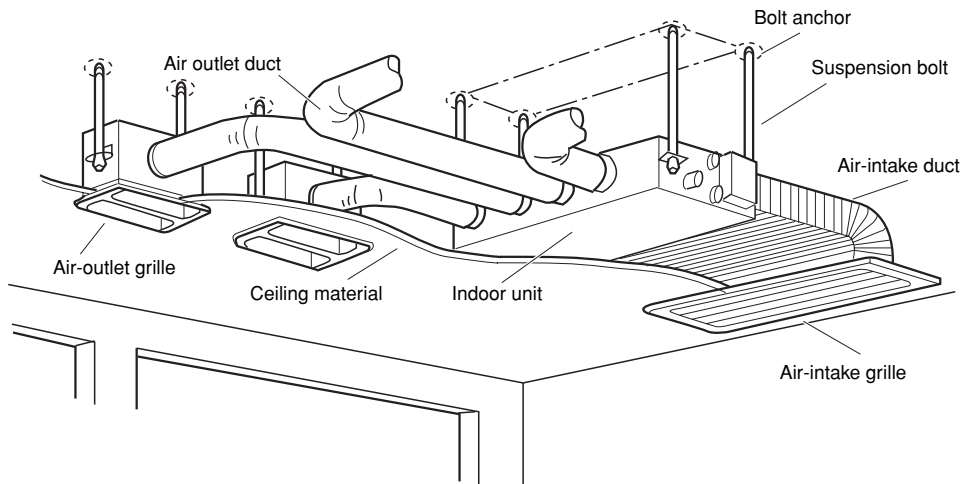

Fig. 3-67

3-16. Installing the Drain Piping

- Prepare standard hard PVC pipe (O.D. 1-1/4") for the drain and use the supplied hose band to prevent water leaks. The PVC pipe must be purchased separately. The transparent drain part on the unit allows you to check drainage. (Fig. 3-68)



CAUTION

- Do not use adhesive at the drain connection port on the indoor unit.
- Insert the drain pipe until it contacts the socket, as shown in the figure at right, then secure it tightly with the hose band.
- Do not use the supplied drain hose bent at a 90° angle. (The maximum permissible bend is 45°.)
- Tighten the hose clamps so their locking nuts face upward. (Fig. 3-68)

- After connecting the drain piping securely, wrap the supplied packing and drain pipe insulator around the pipe, then secure it with the supplied vinyl clamps. (Fig. 3-69)

NOTE

Make sure the drain pipe has a downward gradient (1/100 or more) and that there are no water traps.



CAUTION

- Do not install an air bleeder as this may cause water to spray from the drain pipe outlet. (Fig. 3-70)

- If it is necessary to increase the height of the drain pipe, the section directly after the connection port can be raised a maximum of 19-11/16". Do not raise it any higher than 19-11/16", as this could result in water leaks. (Fig. 3-71)
- Do not install the pipe with an upward gradient from the connection port. This will cause the drain water to flow backward and leak when the unit is not operating. (Fig. 3-72)
- Do not apply force to the piping on the unit side when connecting the drain pipe. The pipe should not be allowed to hang unsupported from its connection to the unit. Fasten the pipe to a wall, frame, or other support as close to the unit as possible. (Fig. 3-73)

3-17. Checking the Drainage

After wiring and drain piping are completed, use the following procedure to check that the water will drain smoothly. For this, prepare a bucket and wiping cloth to catch and wipe up spilled water.

- Connect power to the power terminal board (R, S terminals) inside the electrical component box.
- Remove the tube cover and through the opening, slowly pour about 0.3 gal of water into the drain pan to check drainage.
- Short the check pin (CHK) on the indoor control board and operate the drain pump. Check the water flow through the transparent drain port and see if there is any leakage.

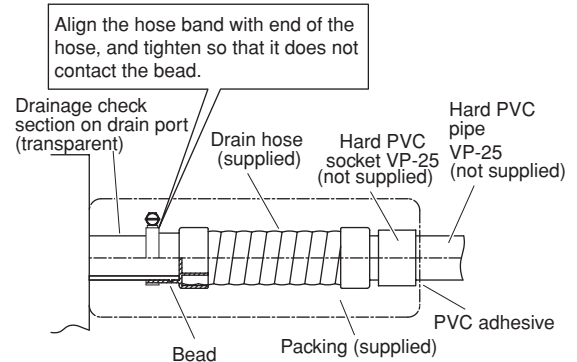

Fig. 3-68

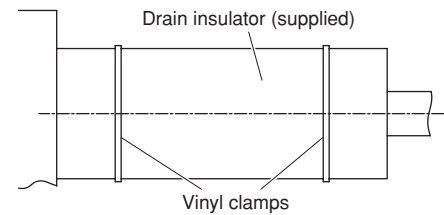

Fig. 3-69

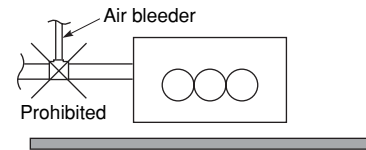

Fig. 3-70

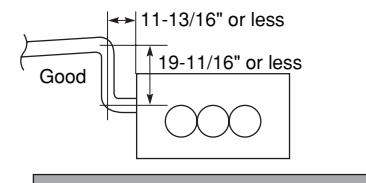

Fig. 3-71

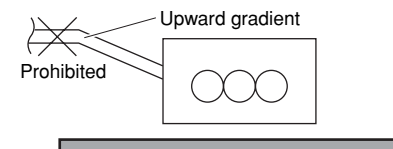

Fig. 3-72

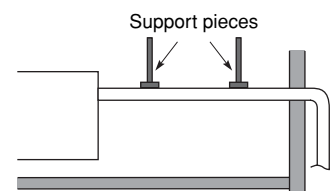

Fig. 3-73



CAUTION

Be careful since the fan will start when you short the pin on the indoor control board.

- (4) When the check of drainage is complete, open the check pin (CHK) and remount the insulator and drain cap onto the drain inspection port.

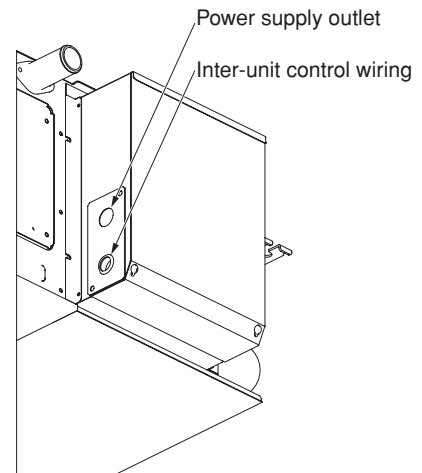

Fig. 3-74



3-18. Increasing the Fan Speed

If external static pressure is too great (due to long extension of ducts, for example), the air flow volume may drop too low at each air outlet. This problem may be solved by increasing the fan speed using the following procedure:

- (1) Remove 4 screws on the electrical component box and remove the cover plate.
- (2) Disconnect the fan motor sockets in the box.
- (3) Take out the booster cable (sockets at both ends) clamped in the box.
- (4) Securely connect the booster cable sockets between the disconnected fan motor sockets in step 2 as shown in Fig. 3-75.
- (5) Place the cable neatly in the box and reinstall the cover plate.

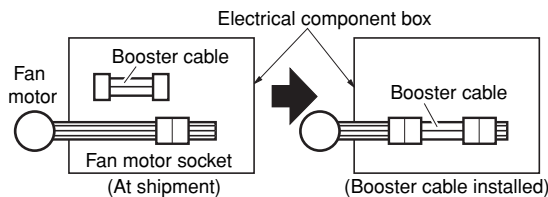
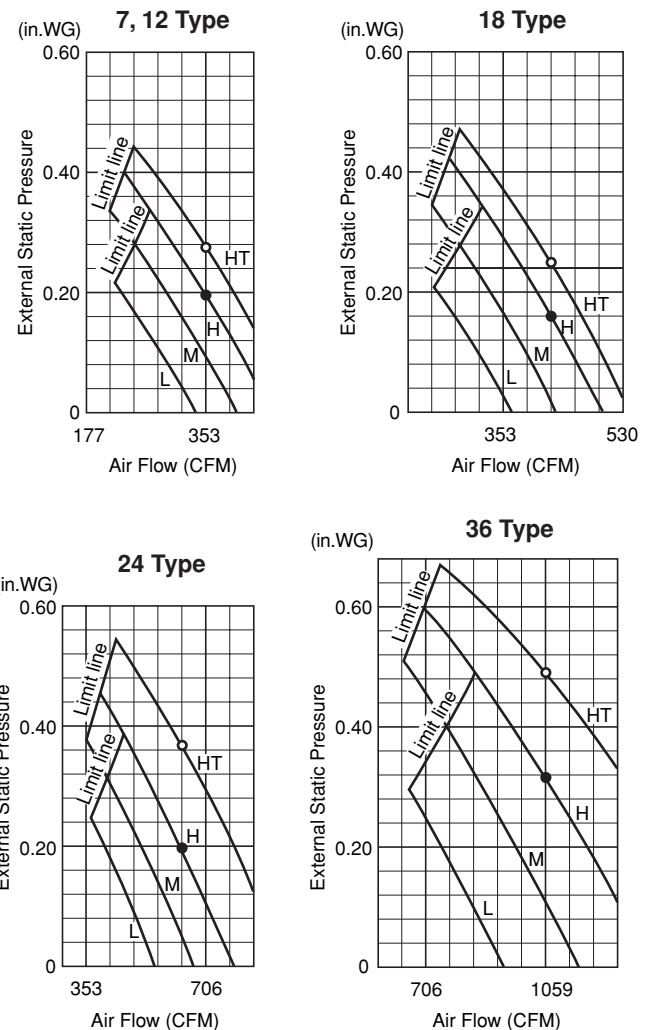

Fig. 3-75

How to read the diagram

The vertical axis is the external static pressure (in.WG) while the horizontal axis represents the air flow (CFM). The characteristic curves for "HT," "H," "M" and "L" fan speed control are shown. The nameplate values are shown based on the "H" air flow. For the 24 type, the air flow is 635 CFM, while the external static pressure is 0.20 in.WG at "H" position. If external static pressure is too great (due to long extension of ducts, for example), the air flow volume may drop too low at each air outlet. This problem may be solved by increasing the fan speed as explained above.

Indoor Fan Performance



NOTE

HT: Using the booster cable

H: At shipment

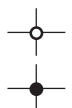

Fig. 3-76

■ Concealed Duct High-Static Pressure Type (D Type)

3-19. Required Minimum Space for Installation and Service

- This air conditioner is usually installed above the ceiling so that the indoor unit and ducts are not visible. Only the air intake and air outlet ports are visible from below.
- The minimum space for installation and service is shown in Fig. 3-77.
- It is recommended that space be provided (23-5/8" × 23-5/8") for checking and servicing the electrical system.
- Fig. 3-78 and Table 3-5 show the detailed dimensions of the indoor unit.

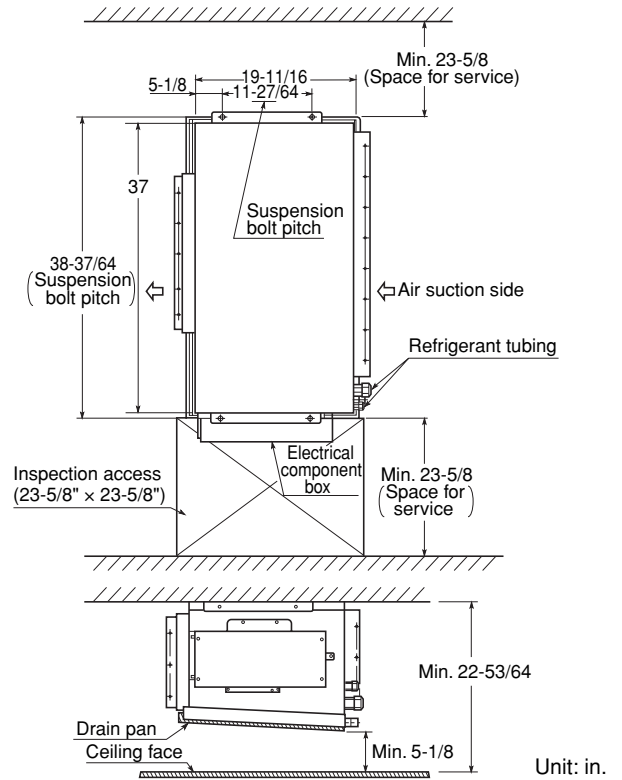

Fig. 3-77

Unit: in.

Table 3-5

Unit: in.

Type	Length	A	B	C
36		16-17/32	15-35/64	2-43/64
48		17-23/32	16-47/64	3-55/64

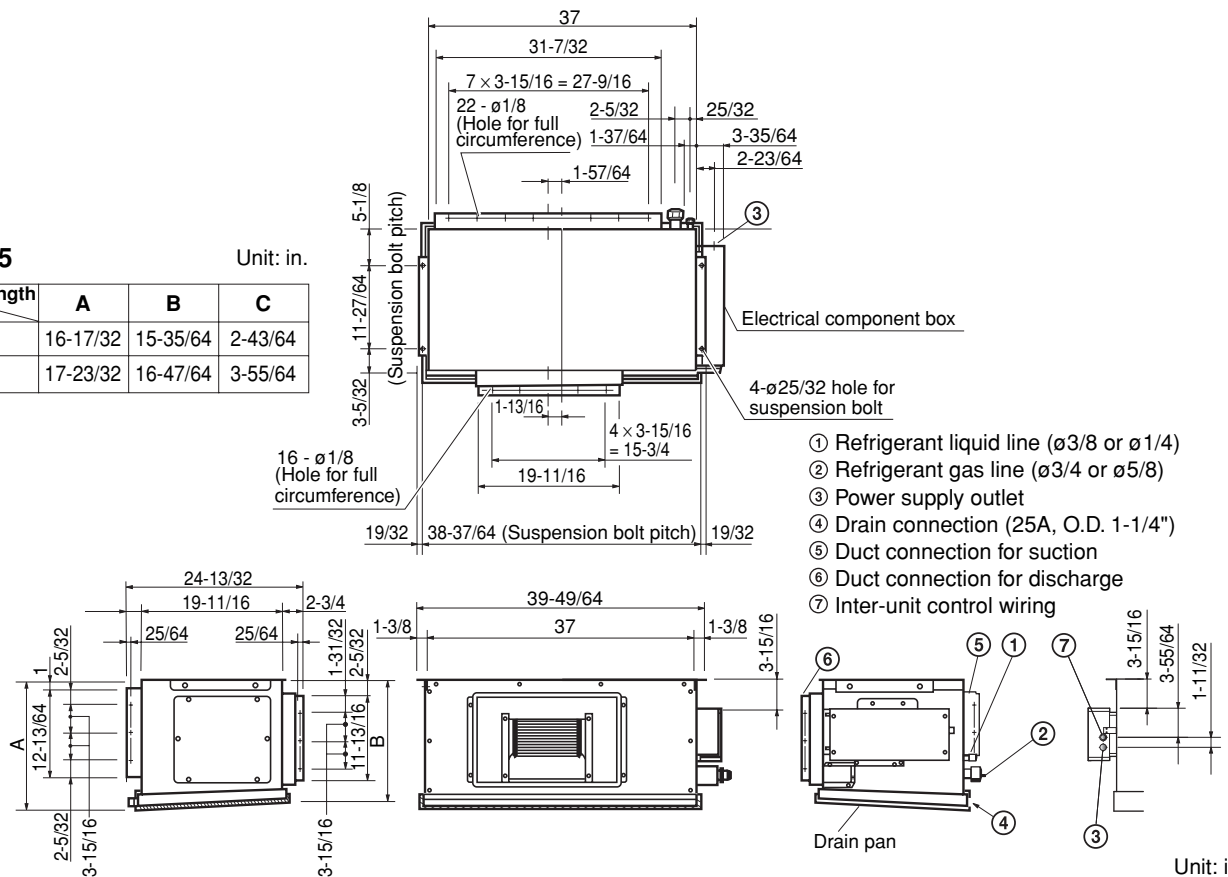

Fig. 3-78

Unit: in.

- ① Refrigerant liquid line (ø3/8 or ø1/4)
- ② Refrigerant gas line (ø3/4 or ø5/8)
- ③ Power supply outlet
- ④ Drain connection (25A, O.D. 1-1/4")
- ⑤ Duct connection for suction
- ⑥ Duct connection for discharge
- ⑦ Inter-unit control wiring

3-20. Suspending the Indoor Unit

Depending on the ceiling type:

- Insert suspension bolts as shown in Fig. 3-79
- or
- Use existing ceiling supports or construct a suitable support as shown in Fig. 3-80.



WARNING

It is important that you use extreme care in supporting the indoor unit inside the ceiling. Ensure that the ceiling is strong enough to support the weight of the unit. Before hanging the unit, test the strength of each attached suspension bolt.

- (1) When placing the unit inside the ceiling, determine the pitch of the suspension bolts referring to the dimensional data given previously. (Figs. 3-77 and 3-78)

Tubing must be laid and connected inside the ceiling when suspending the unit. If the ceiling is already constructed, lay the tubing into position for connection to the unit before placing the unit inside the ceiling.

- (2) Screw in the suspension bolts allowing them to protrude from the ceiling as shown in Fig. 3-79. (Cut the ceiling material, if necessary.)
- (3) Suspend and fix the indoor unit using the 2 hexagonal nuts (field supply) and special washers (supplied with the unit) as shown in Fig. 3-81.

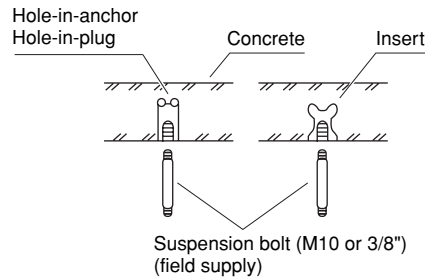

Fig. 3-79

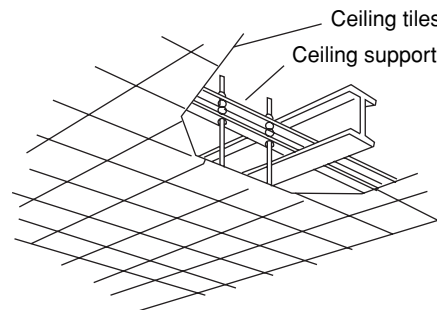

Fig. 3-80

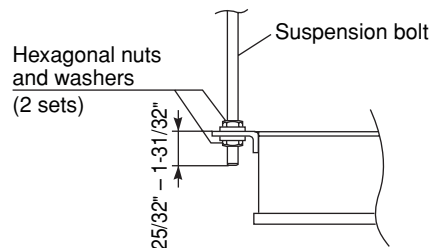

Fig. 3-81

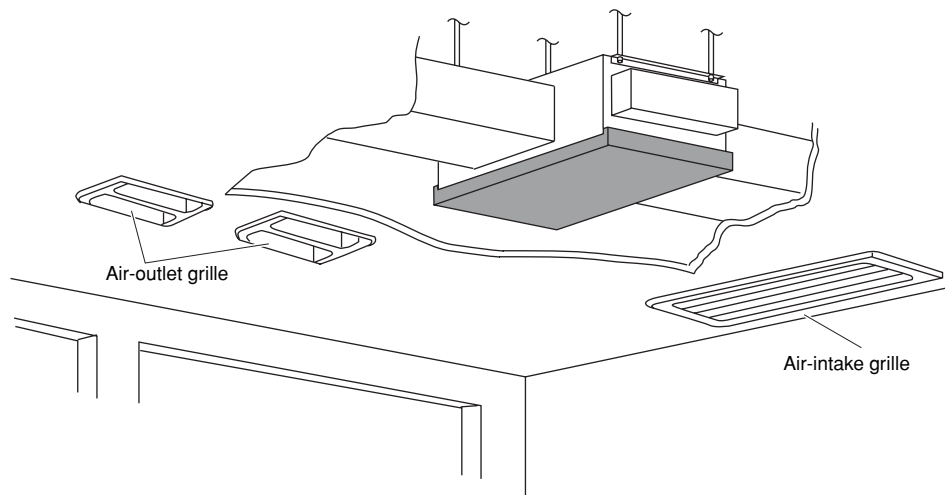

Fig. 3-82

D

3-21. Installing the Drain Piping

- (1) Prepare standard hard PVC pipe (O.D. 1-1/4") for the drain and use the supplied drain socket to prevent water leaks. The PVC pipe must be purchased separately. When doing this, apply adhesive for the PVC pipe at the connection point.
- (2) If connecting a drain joint (supplied) to the threaded drain port, first wrap the drain port threads with sealing tape, then connect the joint. (Fig. 3-83)
- (3) After connecting the drain pipe securely, wrap insulator (field supply) around the pipe.
- (4) Ensure the drain pipe has a downward gradient (1/100 or more) and prepare traps as indicated in Fig. 3-84.
- (5) Also, in another part of the pipe arrangement, prepare traps with an inspection plug to clean dust or debris that may cause leaking of water. (Fig. 3-85)
- (6) After connecting the drain piping, slowly pour water into the drain pan to check that the water drains smoothly.

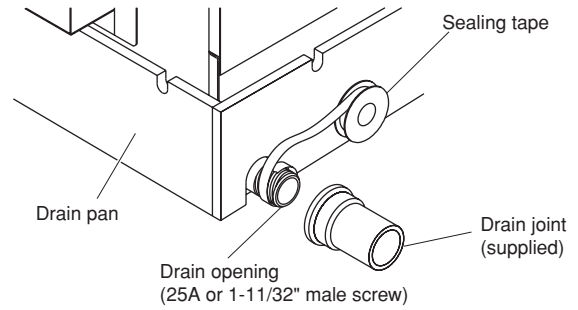

Fig. 3-83

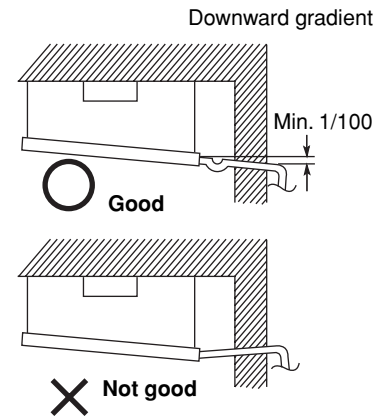

Fig. 3-84

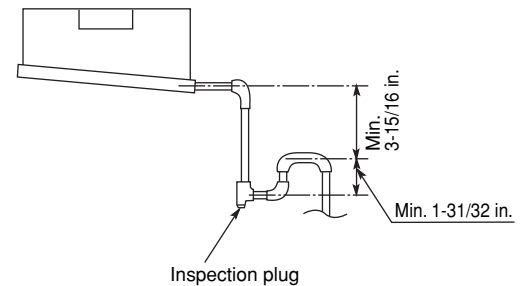

Fig. 3-85

3-22. Caution for Ducting Work

- This unit has high static pressure (applicable external static pressure Max. 0.68 – 0.88 in.WG. In the case of small pressure resistance (for instance, a short duct), install a damper for adjusting air flow volume as air flow volume / air flow noise increases.
- If the air conditioner is to be installed in a room such as an office or meeting room which needs a low sound level, provide a supply and return noise absorption chamber with an acoustic liner.
- Include an air filter (field supply) at the return duct.

3-23. Indoor Fan Performance

How to Read the Diagram

The vertical axis is the External Static Pressure (in.WG) while the horizontal axis represents the Air Flow (CFM). The characteristic curve for the "H," "Med," and "Lo" fan speed control.

The nameplate values are shown based on the "H" air flow. Therefore in the case of 36 Type, the flow is 1059 CFM, while the External Static Pressure is 0.72 in.WG at "H" position. If the external static pressure is too great (due to long extension of duct, for example), the air flow volume may drop too low at each air outlet.

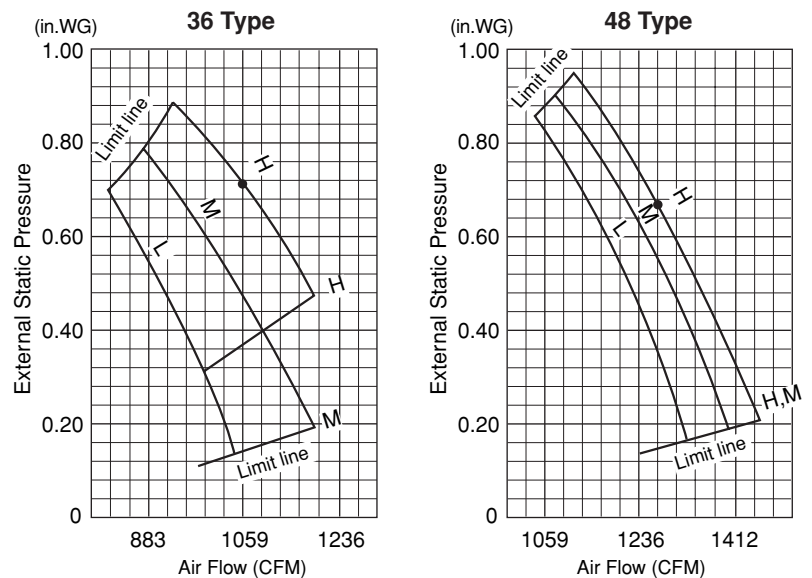

NOTE

H: At shipment



Fig. 3-86

■ Ceiling-Mounted Type (T Type)

3-24. Required Minimum Space for Installation and Service

(1) Dimensions of suspension bolt pitch and unit

Table 3-6 Unit: in.

Dimension Type	A	B	C
12, 18	33-21/32	35-53/64	8-17/64
24	44-19/64	46-29/64	8-17/64

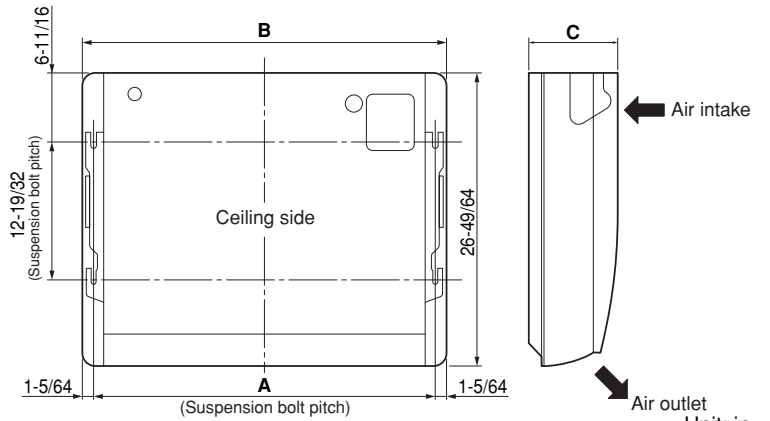

Fig. 3-87

(2) Refrigerant tubing • drain hose position

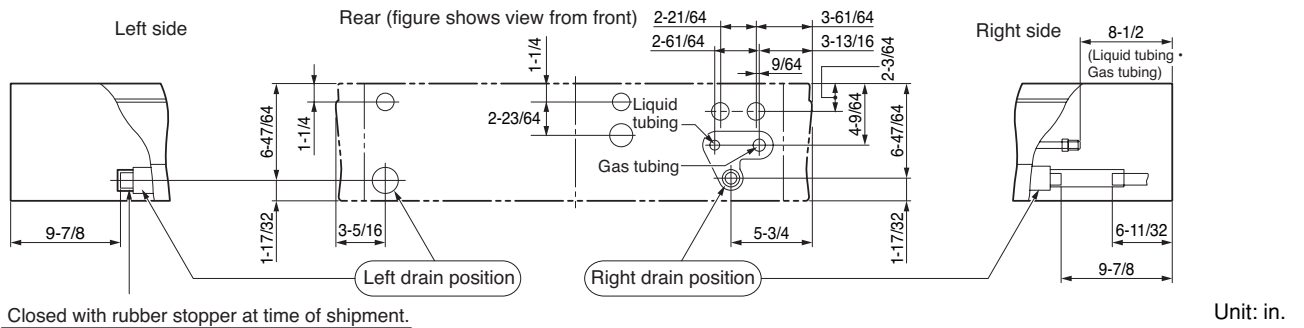
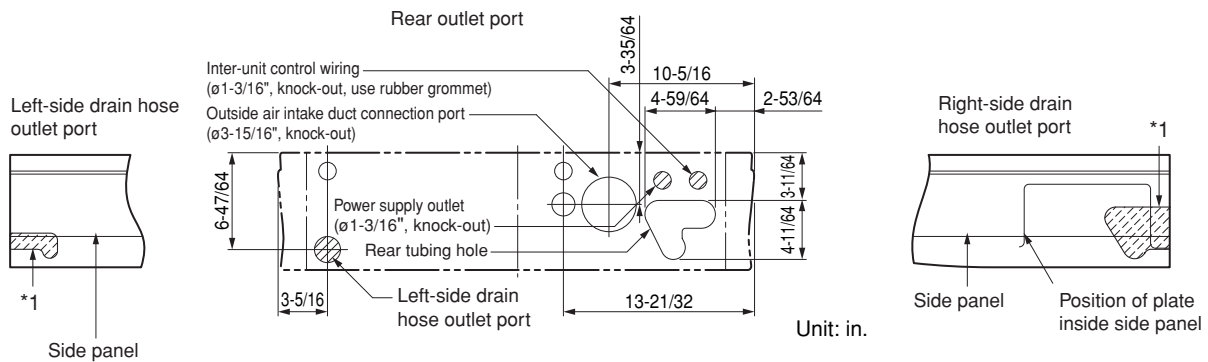

Fig. 3-88

(3) Unit opening position (Refrigerant tubing • drain hose • power inlet port • remote controller wiring inlet port)



*1 Use a compass saw, jig saw or similar tool and cut along the indented portion of the side panel.

Fig. 3-89

(4) Wall and ceiling side opening position

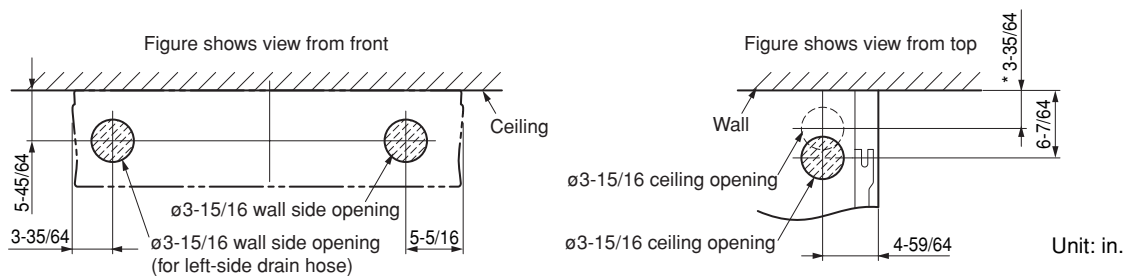

* If the optional drain up kit is installed, create a $\varnothing 3-15/16$ " hole along the dotted line (part marked with * in figure).

Fig. 3-90

3-25. Suspending the Indoor Unit

- (1) Place the full-scale diagram (supplied) on the ceiling at the spot where you want to install the indoor unit. Use a pencil to mark the drill holes. (Fig. 3-91).

NOTE

Since the diagram is made of paper, it may shrink or stretch slightly because of high temperature or humidity. For this reason, before drilling the holes maintain the correct dimensions between the markings.

- (2) Drill holes at the 4 points indicated on the full-scale diagram.
- (3) Depending on the ceiling type:
 - a) Insert suspension bolts as shown in Fig. 3-92.
 - or
 - b) Use existing ceiling supports or construct a suitable support as shown in Fig. 3-93.

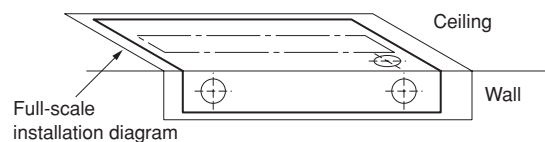

Fig. 3-91

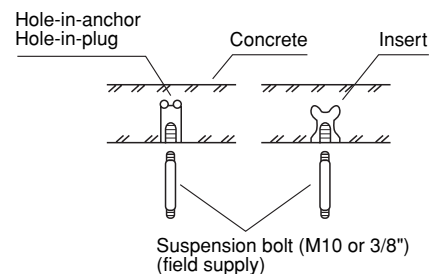

Fig. 3-92



WARNING

It is important that you use extreme care in supporting the indoor unit from the ceiling. Ensure that the ceiling is strong enough to support the weight of the unit. Before hanging the ceiling unit, test the strength of each attached suspension bolt.

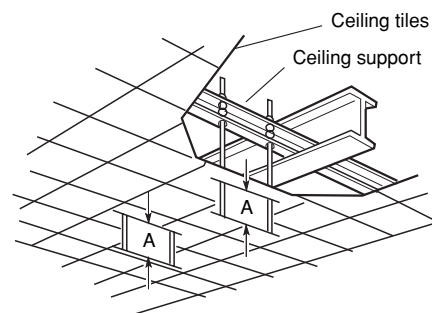

Fig. 3-93

- (4) Screw in the suspension bolts, allowing them to protrude from the ceiling as shown in Figs. 3-92 and 3-93. The distance of each exposed bolt must be of equal length within 1-15/16". (Fig. 3-94)

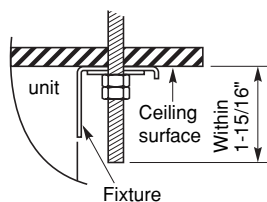

Fig. 3-94

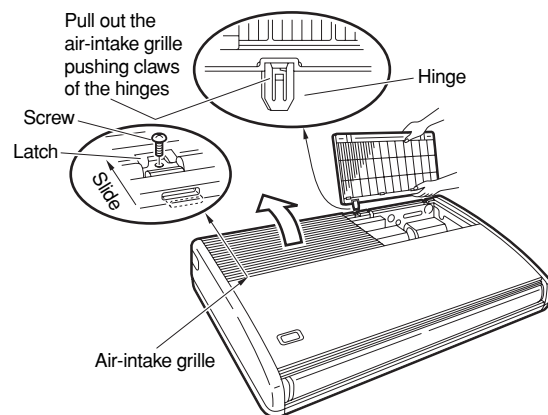

Fig. 3-95

- (5) Before suspending the indoor unit, remove the 2 or 3 screws on the latch of the air-intake grilles, open the grilles, and remove them by pushing the claws of the hinges as shown in Fig. 3-95. Then remove both side panels sliding them along the unit toward the front after removing the 2 attachment screws. (Fig. 3-96)
- (6) Carry out the preparation for suspending the indoor unit. The suspension method varies depending on whether there is a suspended ceiling or not. (Figs. 3-97 and 3-98)
- (7) Suspend the indoor unit as follows:
 - a) Mount 1 washer and 2 hexagonal nuts on each suspension bolt as shown in Fig. 3-99.
 - b) Lift the indoor unit, and place it on the washers through the notches, in order to fix it in place. (Fig. 3-100)
 - c) Tighten the 2 hexagonal nuts on each suspension bolt to suspend the indoor unit as shown in Fig. 3-101.

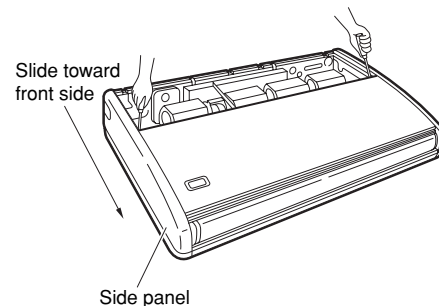

Fig. 3-96

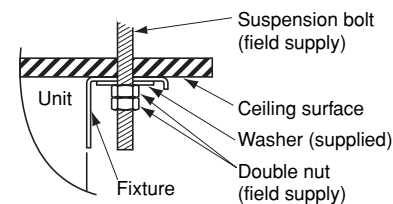

Fig. 3-97

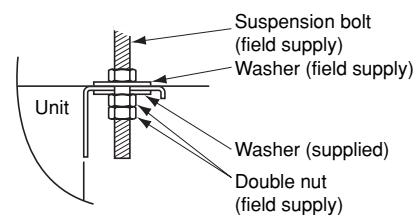

Fig. 3-98

NOTE

The ceiling surface is not always level. Please confirm that the indoor unit is evenly suspended. For the installation to be correct, leave a clearance of about 3/8" between the ceiling panel and the ceiling surface and fill the gap with an appropriate insulation or filler material.

- (8) If the tubing and wiring are to go towards the rear of the unit, make holes in the wall. (Fig. 3-102)
- (9) Measure the thickness of the wall from the inside to the outside and cut PVC pipe at a slight angle to fit. Insert the PVC pipe in the wall. (Fig. 3-103)

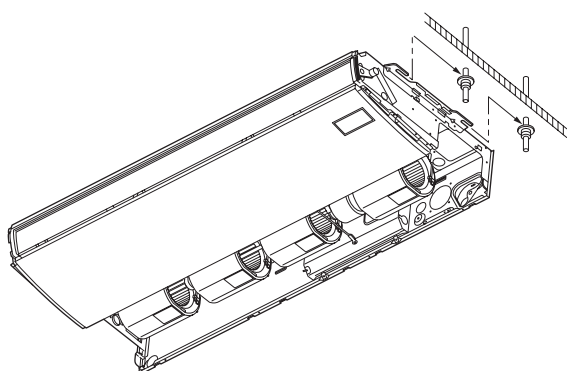

Fig. 3-100

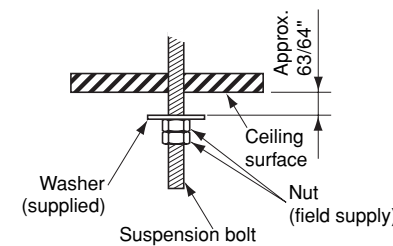

Fig. 3-99

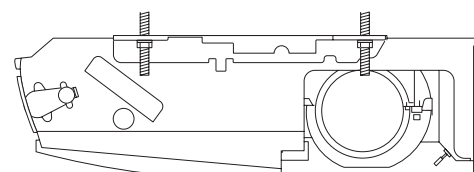

Fig. 3-101

NOTE

The hole should be made at a slight downward slant to the outside.

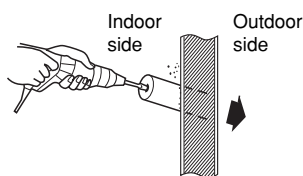

Fig. 3-102

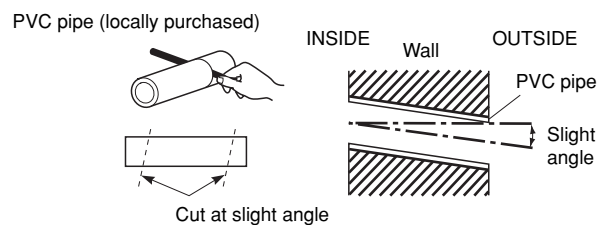

Fig. 3-103

3-26. Duct for Fresh Air

There is a duct connection port (knock-out hole) at the right-rear of the top panel of the indoor unit for drawing in fresh air. If it is necessary to draw in fresh air, remove the cover by opening the hole and connecting the duct to the indoor unit through the connection port. (Fig. 3-104)

3-27. Shaping the Tubing

- The positions of the refrigerant tubing connections are shown in the figure below. (The tubing can be routed in 3 directions.)
- * When routing the tubing out through the top or right sides, knock out the appropriate parts in the top panel and cut notches in the side panel as shown in Fig. 3-89.
- * When routing the tubing out through the top, the optional L-shape tubing kit is required.

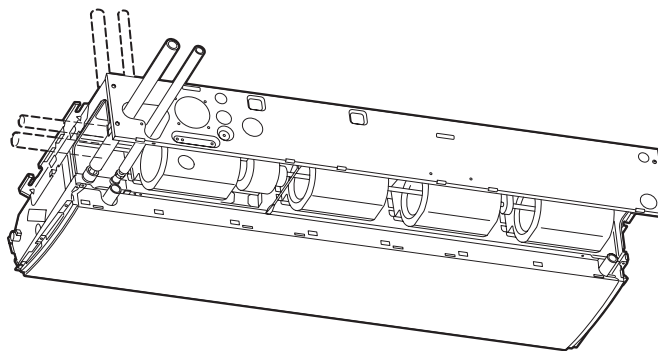

Fig. 3-105

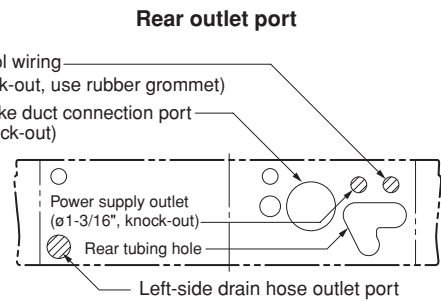

Fig. 3-104

If the tubing is to be routed out together, use a box cutter or similar tool to cut out the part of the rear cover indicated by the marked area in the figure below, to match the positions of the tubes. Then draw out the tubing.

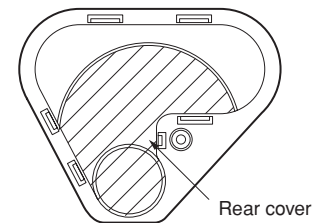

Fig. 3-106

3-28. Installing the Drain Piping

- Prepare standard PVC pipe for the drain and connect it to the indoor unit drain pipe with the supplied hose clamps to prevent water leaks.

(1) Drain hose connection

- The drain hose is connected below the refrigerant tubing.

(2) Installing the drain hose

- To install the drain hose, first place 1 of the 2 hose bands over the unit drain port and the other hose band over the hard PVC pipe (not supplied). Then connect both ends of the supplied drain hose.
- On the unit drain side, grasp the hose band with pliers and insert the drain hose all the way to the base.
- If other commercially available hose bands are used, the drain hose may become pinched or wrinkled and there is danger of water leakage. Therefore be sure to use the supplied hose bands. When sliding the hose bands, be careful to avoid scratching the drain hose.
- Do not use adhesive when connecting the supplied drain hose to the drain port (either on the main unit or the PVC pipe).
- Wrap the hose with the supplied drain hose insulation and use the 4 twist ties so that the hose is insulated with no gaps.
- Connect the drain piping so that it slopes downward from the unit to the outside. (Fig. 3-107)

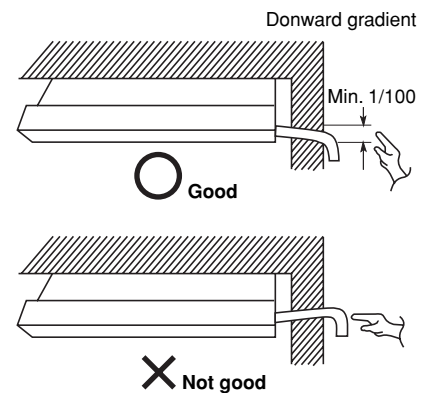

Fig. 3-107



CAUTION

- Attach so that the hose band fastener is on the side of the drain port. (Fig. 3-108)
- Attach the hose bands so that each is approximately 13/64 – 63/64 in. from the end of the supplied drain hose.

- Never allow traps to occur in the course of the piping.
- Insulate any piping inside the room to prevent dripping.
- After the drain piping, pour water into the drain pan to check that the water drains smoothly.
- If the drain hose is to be raised, use the optional drain up kit.

The drain hose can be raised 23-5/8" above the top of the main unit. (For details, refer to the manual of the optional part.)

- * If the drain hose is routed through the left side, refer to Fig. 3-105, and follow the procedure above to install the hose. Re-attach the rubber stopper that was earlier removed onto the right side.

The rubber stopper can be inserted easily by using a screwdriver or similar tool to press the stopper into the drain port on the main unit. Press the stopper into the main unit drain port as far as it will go.

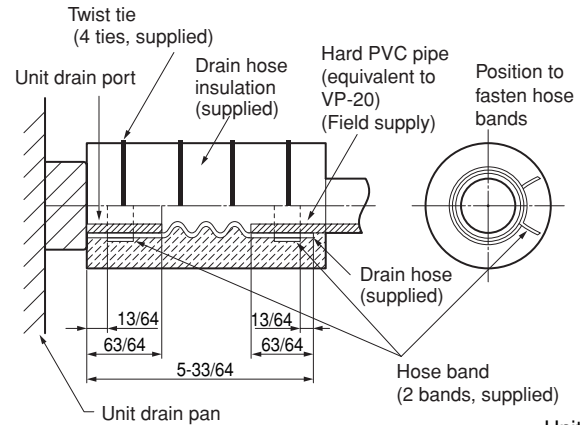
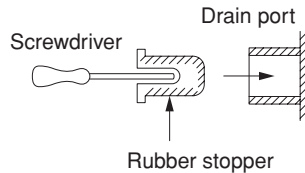

Fig. 3-108

Unit: in.



CAUTION

Check local electrical codes and regulations before wiring. Also, check any specified instruction or limitations.

How to carry out power supply wiring

(1) Wiring connection ports

The power inlet ports are located at the rear and top. The remote controller wiring inlet ports are located at the rear and top (for use with the wired remote controller).

For details, refer to Fig. 3-104. For the method used to insert the wiring, refer to the figure below. (Fig. 3-109)



CAUTION

When removing the fastening bracket from the cover of the electrical component box, use caution to avoid dropping the bracket.

(2) How to carry out wiring

- Open the knock-out hole on the rear or top of the main unit. Attach the supplied rubber grommet and pull the power wiring into the main unit.
- Feed the wiring into the wiring inlet port on the electrical component box. Connect the wiring to the terminal plate and fasten in place with the supplied clamp.
- Perform electrical and grounding work in accordance with the package A/C power specifications, and following local electrical codes and regulations.

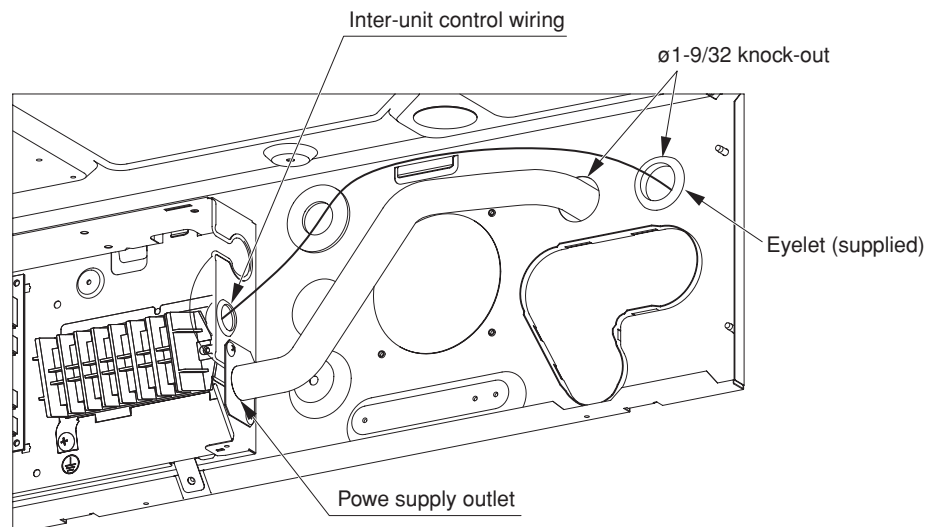

Fig. 3-109

■ Wall-Mounted Type (K Type)

3-29. Removing the Rear Panel from the Unit

- (1) Remove the set screws used to fasten the rear panel to the indoor unit during transportation.
- (2) Press up on the frame at the 2 locations shown by the arrows in the figure at right, and remove the rear panel.

NOTE

Tubing can be extended in 4 directions as shown in Fig. 3-111. Select the direction which will provide the shortest run to the outdoor unit.

3-30. Selecting and Making a Hole

- (1) Remove the rear panel from the indoor unit and place it on the wall at the location selected. Fix the rear panel and hook the unit onto it temporarily. Make sure the unit is horizontal using a carpenter's level or tape measure to measure down from the ceiling.
- (2) Determine which notch of the rear panel should be used. (Fig. 3-112)
- (3) Before drilling a hole, check that there are no studs or pipes behind the determined location. The above precautions are also applicable if tubing goes through the wall in any other location.
- (4) Using a sabre saw, key hole saw or hole-cutting drill attachment, make a hole (dia. 3-5/32") in the wall. (Fig. 3-113)
- (5) Measure the thickness of the wall from the inside edge to the outside edge and cut the PVC pipe at a slight angle 15/64" shorter than the thickness of the wall. (Fig. 3-114)
- (6) Place the plastic cover over the end of the pipe (for indoor side only) and insert in the wall. (Fig. 3-115)

NOTE

The hole should be made at a slight downward gradient to the outside.



CAUTION

Avoid areas where electrical wiring or conduits are located.

3-31. Installing the Rear Panel onto the Wall

Confirm that the wall is strong enough to support the unit. See either Item a) or b) below depending on the wall type.

a) If the Wall is Wooden

- (1) Attach the rear panel to the wall with the 10 screws provided. (Fig. 3-116)

If you are not able to line up the holes in the rear panel with the beam locations marked on the wall, use Rawl plugs or toggle bolts to go through the holes on the panel or drill 3/16" dia. holes in the panel over the stud locations and then mount the rear panel.

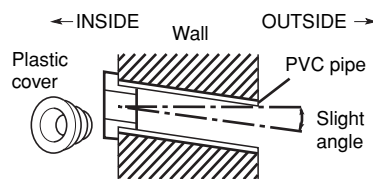

Fig. 3-115

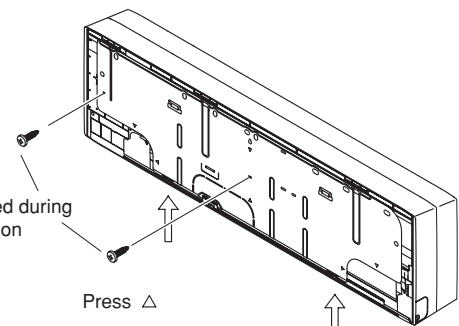

Fig. 3-110

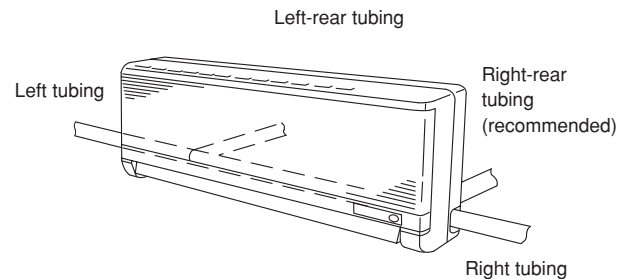
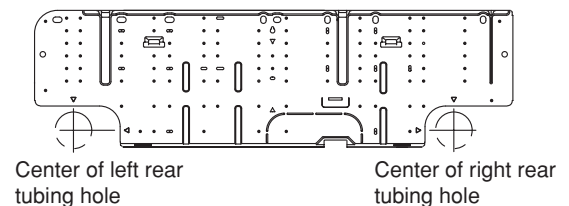

Fig. 3-111



Tubing hole diameter	ø3-5/32
----------------------	---------

Fig. 3-112

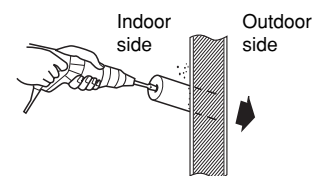
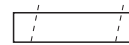
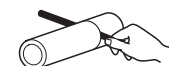

Fig. 3-113

PVC pipe (locally purchased)



Cut at slight angle

Fig. 3-114

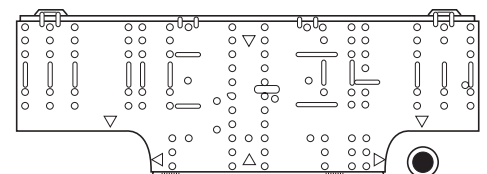

Fig. 3-116

- (2) Check with a tape measure or carpenter's level. This is important so that the unit is correctly installed. (Fig. 3-117)
- (3) Make sure the panel is flush against the wall. Any space between the wall and unit will cause noise and vibration.

b) If the Wall is Brick, Concrete or Similar

Drill 3/16" dia. holes in the wall. Insert Rawl plugs for appropriate mounting screws. (Fig. 3-118)

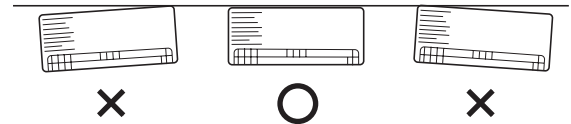

Fig. 3-117

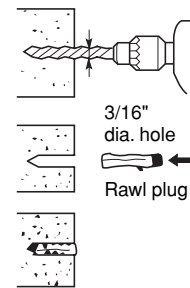

Fig. 3-118

3-32. Removing the Grille to Install the Indoor Unit

In principle, with this model wiring can be completed without removing the grille.

However, if it is necessary to change the settings on the PCB, follow the procedure below.

Removing the grille

- (1) Lift up on both sides of the air-intake grille to open it. (Fig. 3-119)
- (2) Remove the filter. (Fig. 3-119)
- (3) Adjust the flap so that it is horizontal. (Fig. 3-120)
- (4) Open the installation screw covers below the grille (3 locations). (Fig. 3-120)
- (5) Remove the screws. (Fig. 3-120)
- (6) Remove the grille. (Fig. 3-121)

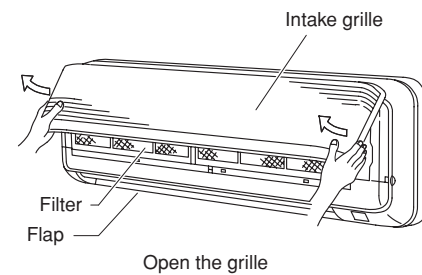

Fig. 3-119

Attaching the grille

- (1) Close the flap.
- (2) Keep the grille installation tabs aligned with the top portion of the grille, and reinstall the lower portion of the grille. Fit the installation tabs into the grooves and press the lower portion of the grille back into its original position to install it.
- (3) Press on the installation tabs to completely close the grille. Check that the grille and frame are fitted tightly together.

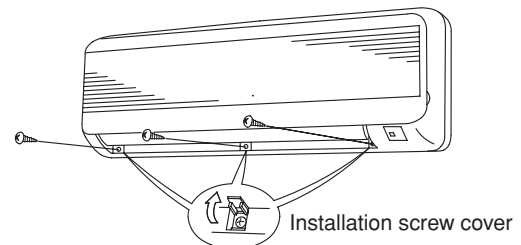

Fig. 3-120

3-33. Preparing the Tubing

- (1) Arrangement of tubing by directions
 - a) Right or left tubing
The corner of the right or left frame should be cut with a hack saw or similar. (Fig. 3-122)
 - b) Right-rear or left-rear tubing
In this case, the corners of the frame do not need to be cut.
- (2) Be sure to insulate the part of the drain hose that is run indoors, and the refrigerant tubing. If these are not insulated, condensation may result in dripping and damage to walls and furniture. The flare nuts on the 24-type (only) are large; therefore, use the supplied insulation material.

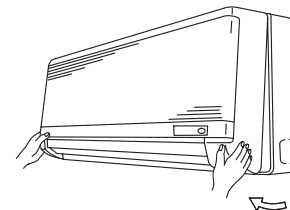

Fig. 3-121

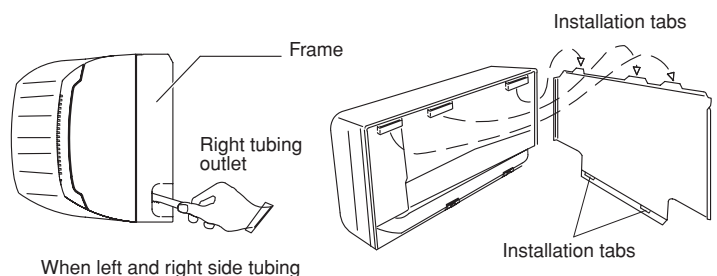

Fig. 3-122

Fig. 3-123



(3) To mount the indoor unit on the rear panel.

1. When installing the indoor unit, position the indoor unit onto the installation tabs on the upper part of the rear panel. (Fig. 3-123)
2. Press on the air outlet to hold it in place, and press the lower part of the indoor unit until a “click” sound is heard and the indoor unit is securely fastened to the installation tabs on the lower side of the rear panel. (Fig. 3-124)

Raising the clamp to lift up the indoor unit will facilitate this work. (Fig. 3-125)

To remove the indoor unit, press up on the 2 locations (△ marks) on the lower part of the unit frame to disconnect the installation tabs. Refer to Section 3-1. “Removing the Rear Panel from the Unit” (Fig. 3-110).

Then lift up the indoor unit to remove it.

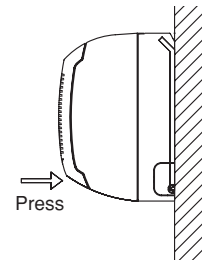

Fig. 3-124

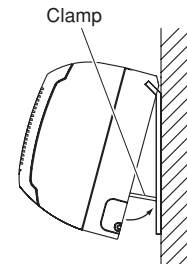

Fig. 3-125

3-34. Shaping the Tubing

Right-rear tubing

- (1) Shape the refrigerant tubing so that it can easily go into the hole. (Fig. 3-126)
- (2) After performing a leak test, wrap both the refrigerant tubing and drain hose together with insulating tape. The drain hose should be positioned below the refrigerant tubes, and should be given sufficient space so that no strong tension is applied to it.
- (3) Push the wiring, refrigerant tubing and drain hose through the hole in the wall. Adjust the indoor unit so it is securely seated on the rear panel.

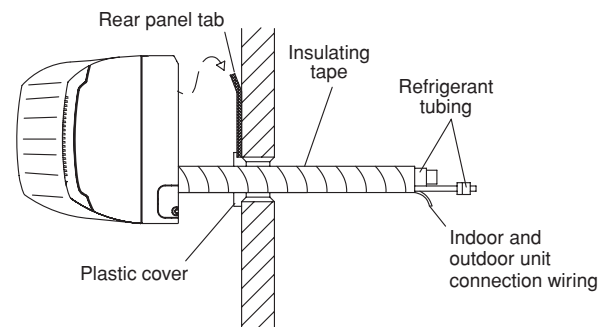

Fig. 3-126

Left or left-rear tubing

- (1) Pass the tubing and drain hose into the rear of the indoor unit. Provide sufficient length for the connections to be made. Next, bend the tubing with a pipe bender, and connect them.
- (2) After performing a leak test, wrap the refrigerant tubing and drain hose together with insulating tape, as shown in the figure at right. (Fig. 3-127) Then fit the tubing into the tubing storage space in the rear of the indoor unit and clamp in place.
- (3) Adjust the indoor unit so that it is securely installed onto the rear panel.

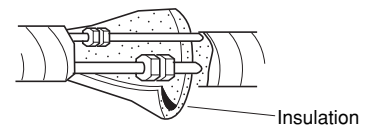

Fig. 3-127

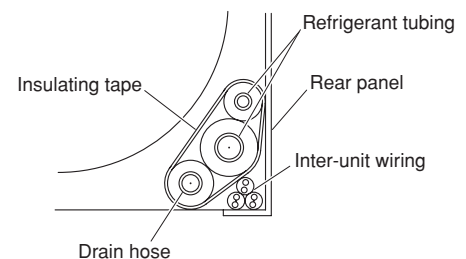

Fig. 3-128

3-35. Installing the Drain Hose

- a) The drain hose should be slanted downward to the outside. (Fig. 3-129)
- b) Never form a trap in the course of the hose.
- c) If the drain hose will run in the room, insulate the hose* so that chilled condensation will not damage furniture or floors.

* Foamed polyethylene or its equivalent is recommended.



WARNING

Do not supply power to the unit or operate it until all tubing and wiring to the outdoor unit are completed.

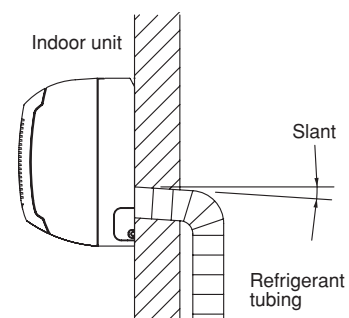

Fig. 3-129

3-36. When Using Wireless Remote Controller Instead Of Wired Remote Controller

When the wireless remote controller is to be used, slide the switch on the indoor unit control PCB.

- If this setting is not made, an alarm will occur. (The operation lamp on the display blinks.)
- This setting is not necessary if both the wired remote controller and wireless remote controller are used.
- The location of the switch varies depending on the type of PCB used. Check the model name before making the setting.

● KHX0752 / 0952 / 1252 / 1852

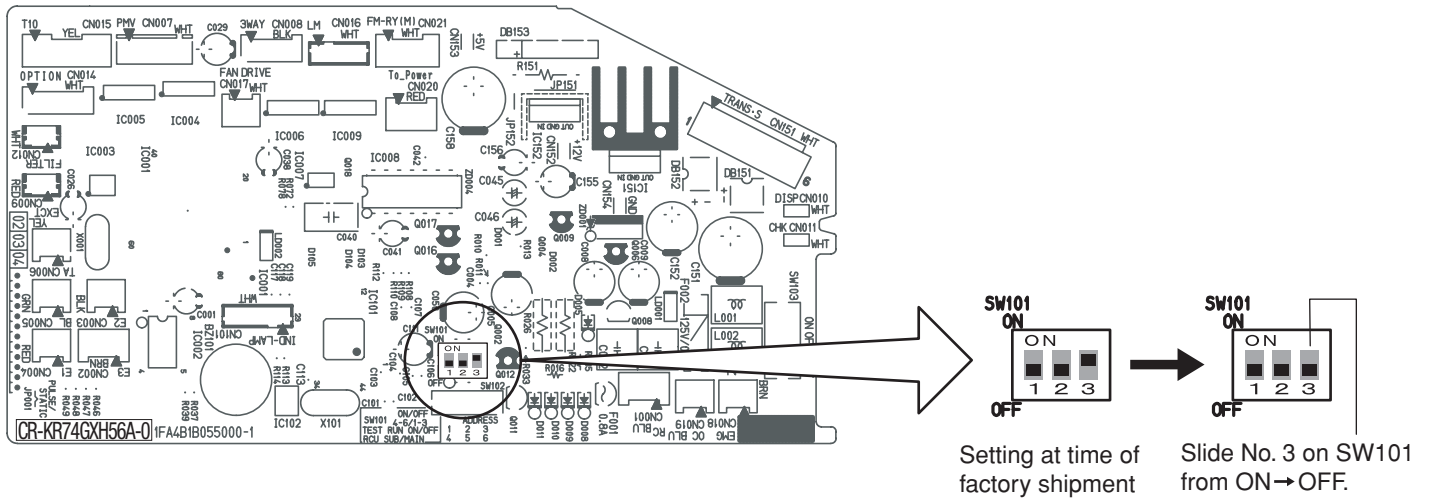

● KHX2452

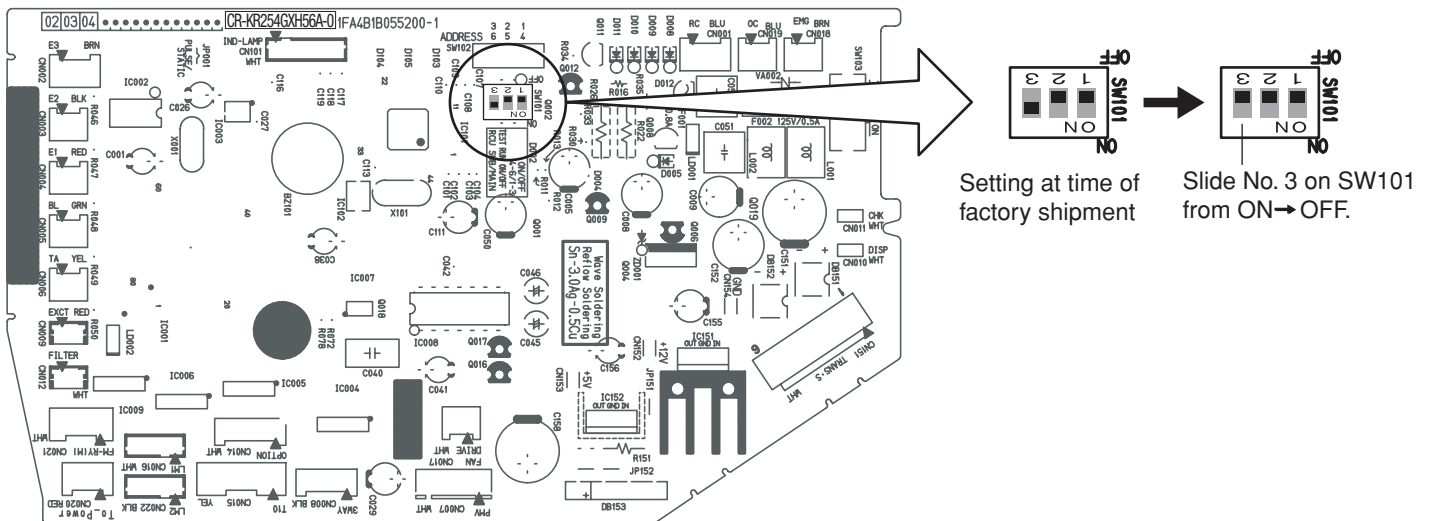

4. HOW TO INSTALL THE OUTDOOR UNIT

4-1. Installing the Outdoor Unit

- Use concrete or a similar material to create the base, and ensure good drainage.
- Ordinarily, ensure a base height of 2 in. or more. If a drain pipe is used, or for use in cold-weather regions, ensure a height of 6 in. or more at the feet on both sides of the unit. (In this case, leave clearance below the unit for the drain pipe, and to prevent freezing of drainage water in cold-weather regions.)
- Refer to the Fig. 4-1 for the anchor bolt dimensions.
- Be sure to anchor the feet with the anchor bolts (M10 or 3/8"). In addition, use anchoring washers on the top side. (Use large square 1-1/4" × 1-1/4" SUS washers with diameters of 3/8".) (Field supply)

4-2. Drainage Work

Follow the procedure below to ensure adequate draining for the outdoor unit.

- For the drain port dimensions, refer to the figure at right.
- Ensure a base height of 6 in. or more at the feet on both sides of the unit.

4-3. Routing the Tubing and Wiring

- The tubing and wiring can be extended out in 4 directions: front, rear, right, and down.
- The service valves are housed inside the unit. To access them, remove the inspection panel. (To remove the inspection panel, remove the 3 screws, then slide the panel downward and pull it toward you.)

- (1) If the routing direction is through the front, rear, or right, use a nipper or similar tool to cut out the knockout holes for the inter-unit control wiring outlet, power wiring outlet, and tubing outlet from the appropriate covers A and B.
- (2) If the routing direction is down, use a nipper or similar tool to cut out the lower flange from cover A.



CAUTION

- **Route the tubing so that it does not contact the compressor, panel, or other parts inside the unit. Increased noise will result if the tubing contacts these parts.**
- **When routing the tubing, use a tube bender to bend the tubes.**

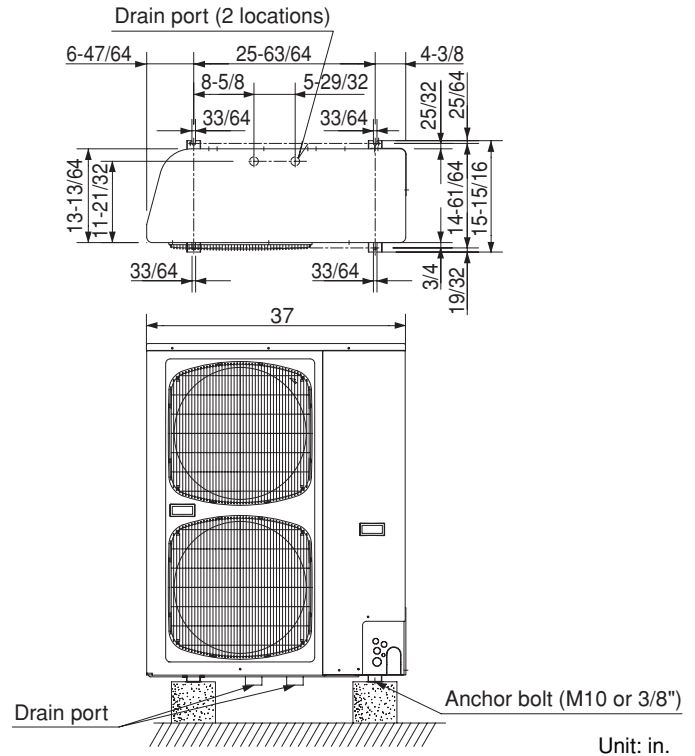

Fig. 4-1

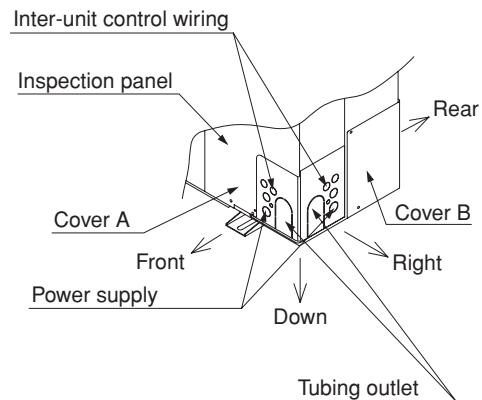

Fig. 4-2

5. ELECTRICAL WIRING

5-1. General Precautions on Wiring

- (1) Before wiring, confirm the rated voltage of the unit as shown on its nameplate, then carry out the wiring closely following the wiring diagram.
- (2) Provide a power outlet to be used exclusively for each unit, and a power supply disconnect and circuit breaker for overcurrent protection should be provided in the exclusive line.
- (3) To prevent possible hazards from insulation failure, the unit must be grounded.
- (4) Each wiring connection must be done in accordance with the wiring system diagram. Wrong wiring may cause the unit to misoperate or become damaged.
- (5) Do not allow wiring to touch the refrigerant tubing, compressor, or any moving parts of the fan.
- (6) Unauthorized changes in the internal wiring can be very dangerous. The manufacturer will accept no responsibility for any damage or misoperation that occurs as a result of such unauthorized changes.
- (7) Regulations on wire diameters differ from locality to locality. For field wiring rules, please refer to your LOCAL ELECTRICAL CODES before beginning.
You must ensure that installation complies with all relevant rules and regulations.
- (8) To prevent malfunction of the air conditioner caused by electrical noise, care must be taken when wiring as follows:
 - The remote control wiring and the inter-unit control wiring should be wired apart from the inter-unit power wiring.
 - Use shielded wires for inter-unit control wiring between units and ground the shield on both sides.
- (9) If the power supply cord of this appliance is damaged, it must be replaced by a repair shop appointed by the manufacturer, because special purpose tools are required.

5-2. Recommended Wire Length and Wire Diameter for Power Supply System

Outdoor unit

Type	(A) Power supply wiring	Time delay fuse or circuit capacity
CHX03652	For field wiring rules, please refer to your LOCAL ELECTRICAL CODES	30 A
CHX06052		50 A

Indoor unit

Type	(B) Power supply wiring	Time delay fuse or circuit capacity
K	For field wiring rules, please refer to your LOCAL ELECTRICAL CODES	15 A
A, X, T, U		15 A
D		15 A

Control wiring

(C) Inter-unit (between outdoor and indoor units) control wiring	(D) Remote control wiring	(E) Control wiring for group control
AWG #18 (0.75 mm ²) Use shielded wiring*	AWG #18 (0.75 mm ²) Use shielded wiring	AWG #18 (0.75 mm ²) Use shielded wiring
Max. 3,280 ft.	Max. 1,640 ft.	Max. 1,640 ft. (Total)

NOTE

* With ring-type wire terminal.

5-3. Wiring System Diagram

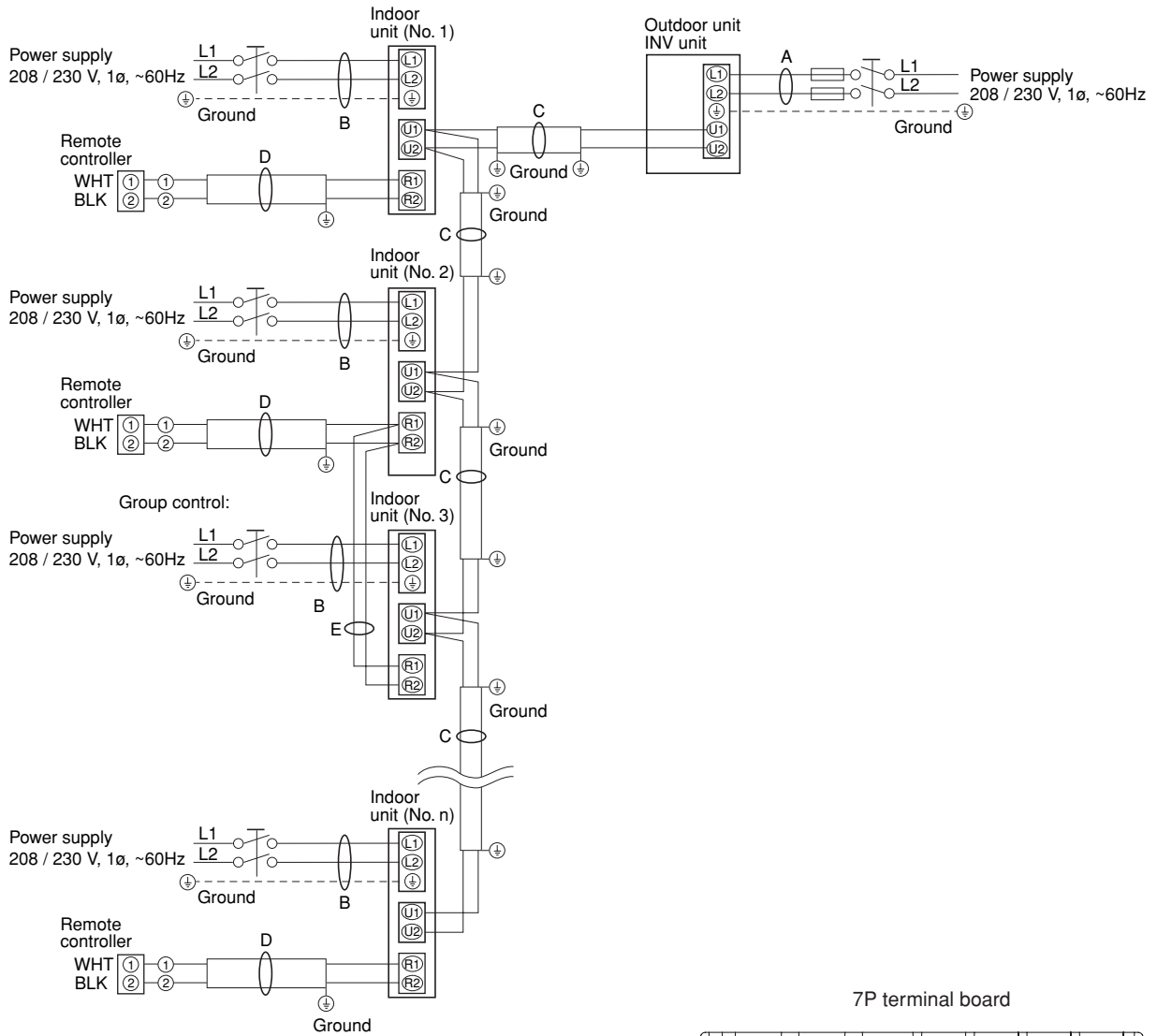

NOTE

- (1) Refer to Section 5-2. "Recommended Wire Length and Wire Diameter for Power Supply System" for the explanation of "A," "B," "C," "D," and "E," in the above diagram.
- (2) The basic connection diagram of the indoor unit shows the 7P terminal board, so the terminal boards in your equipment may differ from the diagram.
- (3) Refrigerant Circuit (R.C.) address should be set before turning the power on.
- (4) Regarding the R.C. address setting, refer to page 72. Auto. address setting can be executed by remote controller automatically. Refer to page 72 – 76.

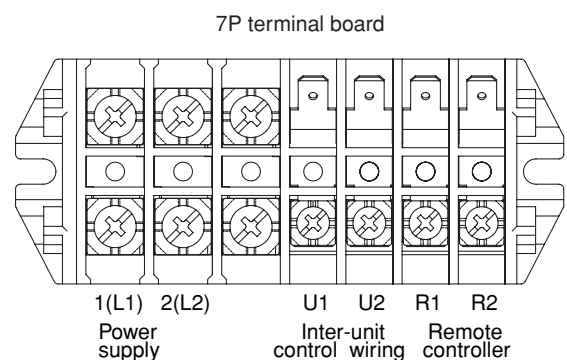

X, A, U, D, T Type

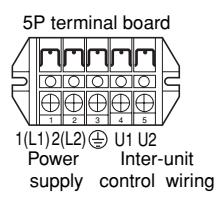

K Type



CAUTION

(1) When linking outdoor units in a network (S-net link system), disconnect the terminal extended from the short plug (CN003, 2P Black, location: right bottom on the outdoor main control PCB) from all outdoor units except any one of the outdoor units.

(When shipping: In shorted condition.)

Otherwise the communication of S-net link system is not performed. For a system without link (no connection wiring between outdoor units), do not remove the short plug.

(2) Do not install the inter-unit control wiring in a way that forms a loop. (Fig. 5-1)

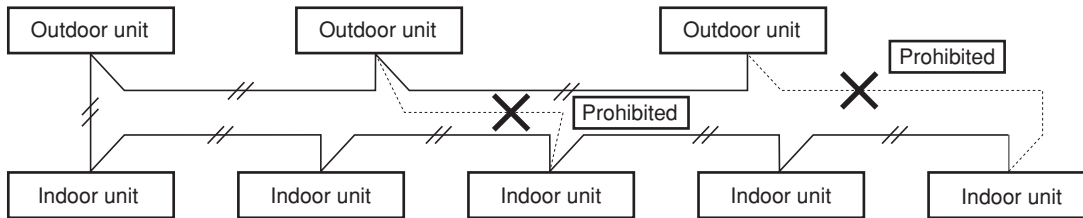

Fig. 5-1

(3) Do not install inter-unit control wiring such as star branch wiring. Star branch wiring causes mis-address setting.

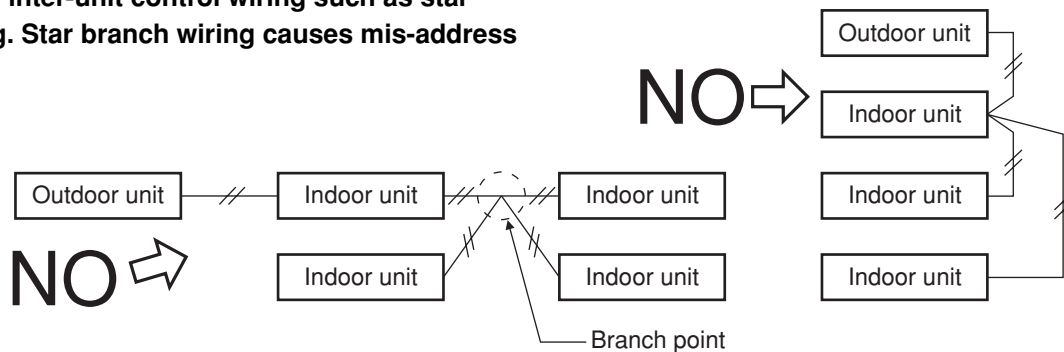

Fig. 5-2

(4) If branching the inter-unit control wiring, the number of branch points should be 16 or fewer. (Branches less than 3.3 ft. are not included in the total branch number.) (Fig. 5-3)

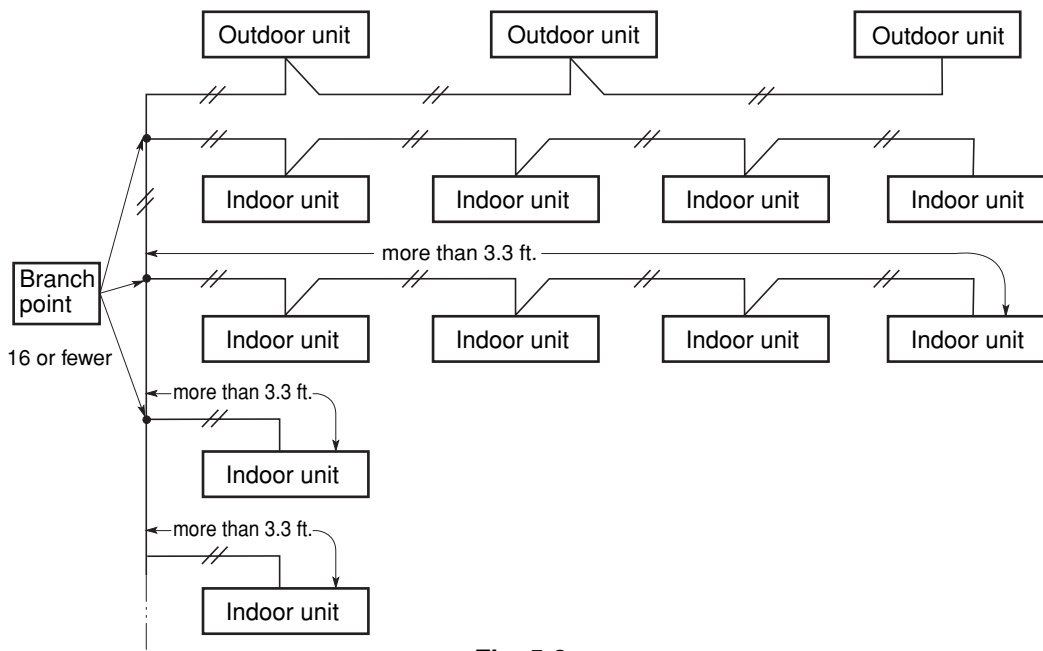

Fig. 5-3

- (5) Use shielded wires for inter-unit control wiring (c) and ground the shield on both sides, otherwise misoperation from noise may occur. (Fig. 5-4)
Connect wiring as shown in Section “5-3. Wiring System Diagram.”



WARNING

Loose wiring may cause the terminal to overheat or result in unit malfunction. A fire hazard may also exist. Therefore, ensure that all wiring is tightly connected.

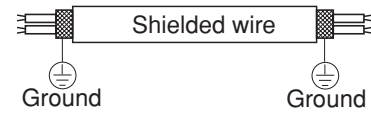

Fig. 5-4

When connecting each power wire to the terminal, follow the instructions on “How to connect wiring to the terminal” and fasten the wire securely with the fixing screw of the terminal plate.

How to connect wiring to the terminal

■ **For stranded wiring**

- (1) Cut the wire end with cutting pliers, then strip the insulation to expose the stranded wiring about 3/8 in. and tightly twist the wire ends. (Fig. 5-5)
- (2) Using a Phillips head screwdriver, remove the terminal screw(s) on the terminal plate.
- (3) Using a ring connector fastener or pliers, securely clamp each stripped wire end with a ring pressure terminal.
- (4) Place the ring pressure terminal, and replace and tighten the removed terminal screw using a screwdriver. (Fig. 5-6)

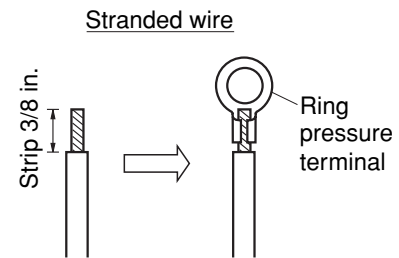

Fig. 5-5

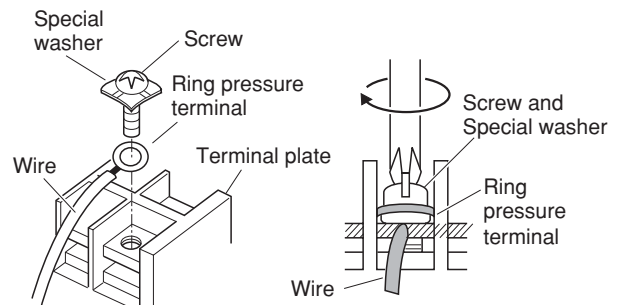

Fig. 5-6

6. HOW TO PROCESS TUBING

6-1. Connecting the Refrigerant Tubing

Use of the Flaring Method

Many of conventional split system air conditioners employ the flaring method to connect refrigerant tubes which run between indoor and outdoor units. In this method, the copper tubes are flared at each end and connected with flare nuts.

Flaring Procedure with a Flare Tool

- (1) Cut the copper tube to the required length with a tube cutter. It is recommended to cut approx. 1 – 2 ft. longer than the tubing length you estimate.
- (2) Remove burrs at the end of the copper tube with a tube reamer or file. This process is important and should be done carefully to make a good flare. (Fig. 6-1)

NOTE

When reaming, hold the tube end downward and be sure that no copper scraps fall into the tube. (Fig. 6-2)

- (3) Remove the flare nut from the unit and be sure to mount it on the copper tube.
- (4) Make a flare at the end of copper tube with a flare tool.* (Fig. 6-3)
(*Use "RIGID®" or equivalent.)

NOTE

A good flare should have the following characteristics:

- inside surface is glossy and smooth
- edge is smooth
- tapered sides are of uniform length

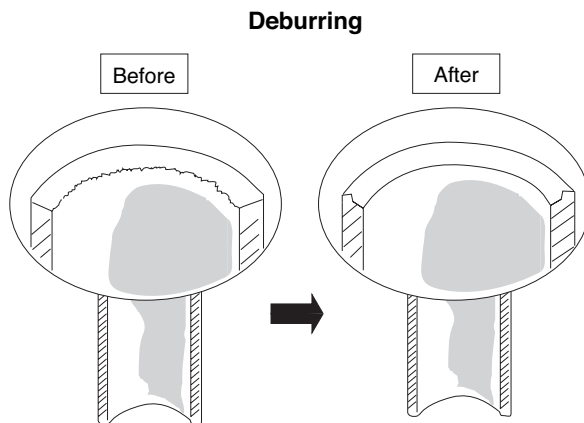

Fig. 6-1

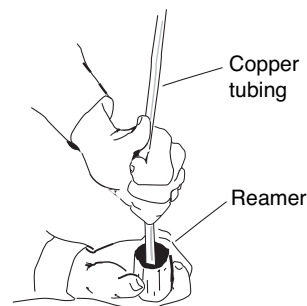

Fig. 6-2

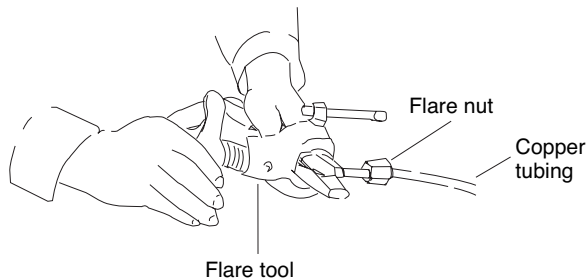

Fig. 6-3

Caution Before Connecting Tubes Tightly

- (1) Apply a sealing cap or water-proof tape to prevent dust or water from entering the tubes before they are used.
 - (2) Be sure to apply refrigerant lubricant to the matching surfaces of the flare and union before connecting them together. This is effective for reducing gas leaks. (Fig. 6-4)
 - (3) For proper connection, align the union tube and flare tube straight with each other, then screw in the flare nut lightly at first to obtain a smooth match. (Fig. 6-5)
- Adjust the shape of the liquid tube using a tube bender at the installation site and connect it to the liquid tubing side valve using a flare.

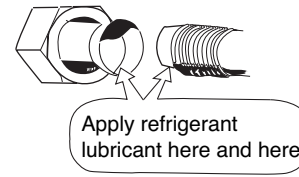

Fig. 6-4

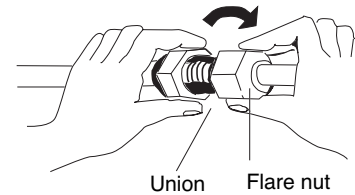

Fig. 6-5

Cautions During Brazing

- Replace air inside the tube with nitrogen gas to prevent copper oxide film from forming during the brazing process. (Oxygen, carbon dioxide and Freon are not acceptable.)
- Do not allow the tubing to get too hot during brazing. The nitrogen gas inside the tubing may overheat, causing refrigerant system valves to become damaged. Therefore allow the tubing to cool when brazing.
- Use a reducing valve for the nitrogen cylinder.
- Do not use agents intended to prevent the formation of oxide film. These agents adversely affect the refrigerant and refrigerant oil, and may cause damage or malfunctions.

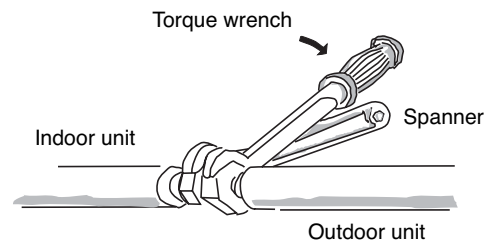

Fig. 6-6

6-2. Connecting Tubing Between Indoor and Outdoor Units

- (1) Tightly connect the indoor-side refrigerant tubing extended from the wall with the outdoor-side tubing.
- (2) To fasten the flare nuts, apply specified torque as at right:
 - When removing the flare nuts from the tubing connections, or when tightening them after connecting the tubing, be sure to use 2 monkey wrenches or spanners as shown. (Fig. 6-6)
 If the flare nuts are over-tightened, the flare may be damaged, which could result refrigerant leakage and cause in injury or asphyxiation to room occupants.
- For the flare nuts at tubing connections, be sure to use the flare nuts that were supplied with the unit, or else flare nuts for R410A (type 2). The refrigerant tubing that is used must be of the correct wall thickness as shown in the table at right.

Tube diameter	Tightening torque, approximate	Tube thickness
ø1/4" (ø6.35 mm)	120 – 160 lbs · in. (140 – 180 kgf · cm)	1/32" (0.8 mm)
ø3/8" (ø9.52 mm)	300 – 360 lbs · in. (340 – 420 kgf · cm)	1/32" (0.8 mm)
ø1/2" (ø12.7 mm)	430 – 530 lbs · in. (490 – 610 kgf · cm)	1/32" (0.8 mm)
ø5/8" (ø15.88 mm)	590 – 710 lbs · in. (680 – 820 kgf · cm)	5/128" (1.0 mm)
ø3/4" (ø19.05 mm)	870 – 1040 lbs · in. (1000 – 1200 kgf · cm)	over 5/128" (1.0 mm)

Because the pressure is approximately 1.6 times higher than conventional refrigerant pressure, the use of ordinary flare nuts (type 1) or thin-walled tubes may result in tube rupture, injury, or asphyxiation caused by refrigerant leakage.

- In order to prevent damage to the flare caused by over-tightening of the flare nuts, use the table above as a guide when tightening.
- When tightening the flare nut on the liquid tube, use a monkey wrench with a nominal handle length of 7-7/8 in.

6-3. Insulating the Refrigerant Tubing

Tubing Insulation

- Thermal insulation must be applied to all unit tubing, including distribution joint (purchased separately).
 - * For gas tubing, the insulation material must be heat resistant to 248°F or above. For other tubing, it must be heat resistant to 176°F or above.
- Insulation material thickness must be 25/64" or greater. If the conditions inside the ceiling exceed DB 86°F and RH 70%, increase the thickness of the gas tubing insulation material by 1 step.

Two tubes arranged together

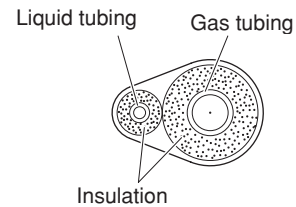

Fig. 6-7

Taping the flare nuts



CAUTION

If the exterior of the outdoor unit valves has been finished with a square duct covering, make sure you allow sufficient space to use the valves and to allow the panels to be attached and removed.

Wind the white insulation tape around the flare nuts at the gas tube connections. Then cover up the tubing connections with the flare insulator, and fill the gap at the union with the supplied black insulation tape. Finally, fasten the insulator at both ends with the supplied vinyl clamps. (Fig. 6-8)

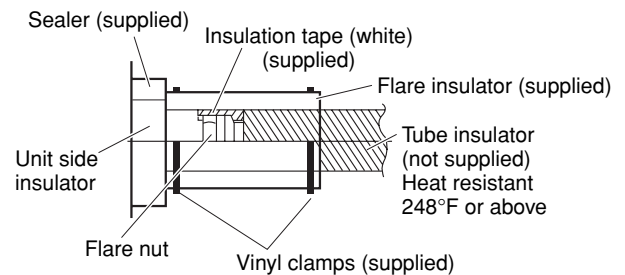

Fig. 6-8

Insulation material

The material used for insulation must have good insulation characteristics, be easy to use, be age resistant, and must not easily absorb moisture.



CAUTION

After a tube has been insulated, never try to bend it into a narrow curve because it can cause the tube to break or crack.

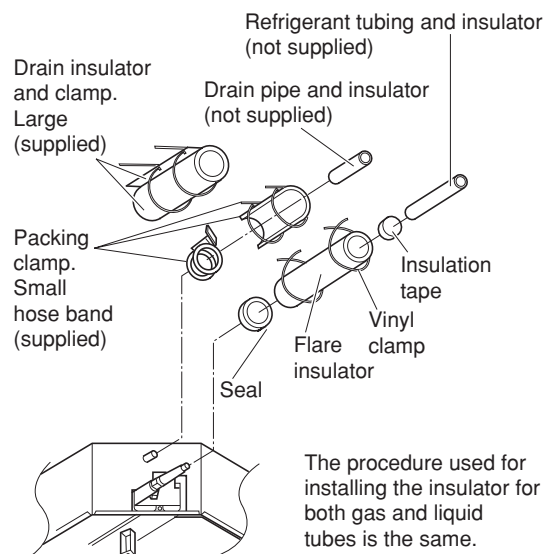

Fig. 6-9

Never grasp the drain or refrigerant connecting outlets when moving the unit.

6-4. Taping the Tubes

- (1) At this time, the refrigerant tubes (and electrical wiring if local codes permit) should be taped together with armoring tape in 1 bundle. To prevent the condensation from overflowing the drain pan, keep the drain hose separate from the refrigerant tubing.
- (2) Wrap the armoring tape from the bottom of the outdoor unit to the top of the tubing where it enters the wall. As you wrap the tubing, overlap half of each previous tape turn.
- (3) Clamp the tubing bundle to the wall, using 1 clamp approx. each ft. (Fig. 6-10)

NOTE

Do not wind the armoring tape too tightly since this will decrease the heat insulation effect. Also ensure that the condensation drain hose splits away from the bundle and drips clear of the unit and the tubing.

6-5. Finishing the Installation

After finishing insulating and taping over the tubing, use sealing putty to seal off the hole in the wall to prevent rain and draft from entering. (Fig. 6-11)

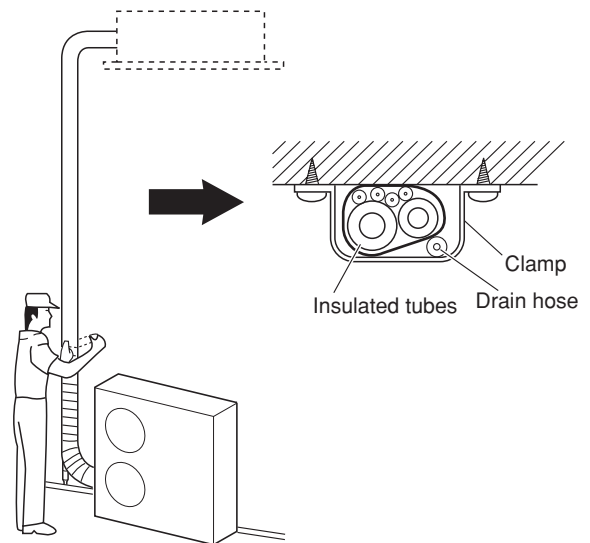

Fig. 6-10

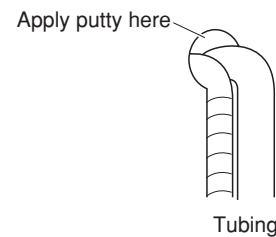

Fig. 6-11

7. AIR PURGING

Air and moisture in the refrigerant system may have undesirable effects as indicated below.

- pressure in the system rises
- operating current rises
- cooling (or heating) efficiency drops
- moisture in the refrigerant circuit may freeze and block capillary tubing
- water may lead to corrosion of parts in the refrigerant system

Therefore, the indoor unit and tubing between the indoor and outdoor unit must be leak tested and evacuated to remove any noncondensables and moisture from the system.

■ Air Purging with a Vacuum Pump (for Test Run) Preparation

Check that each tube (both liquid and gas tubes) between the indoor and outdoor units has been properly connected and all wiring for the test run has been completed. Remove the valve caps from both the gas tube and liquid tube service valves on the outdoor unit. Note that both liquid and gas tube service valves on the outdoor unit are kept closed at this stage.

Leak test

- (1) Attach a manifold valve (with pressure gauges) and dry nitrogen gas cylinder to this service port with charge hoses.



CAUTION

Use a manifold valve for air purging. If it is not available, use a stop valve for this purpose. The "Hi" knob of the manifold valve must always be kept closed.

- (2) Pressurize the system to no more than 512 psig (36 kgf/cm²G) with dry nitrogen gas and close the cylinder valve when the gauge reading reaches 512 psig (36 kgf/cm²G). Then, test for leaks with liquid soap.



CAUTION

To avoid nitrogen entering the refrigerant system in a liquid state, the top of the cylinder must be higher than the bottom when you pressurize the system. Usually, the cylinder is used in a vertical standing position. (Refer to the previous page.)

Manifold gauge

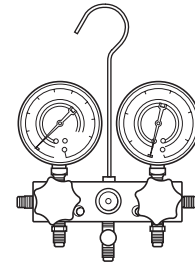

Fig. 7-1

Vacuum pump

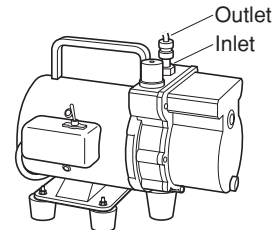

Fig. 7-2

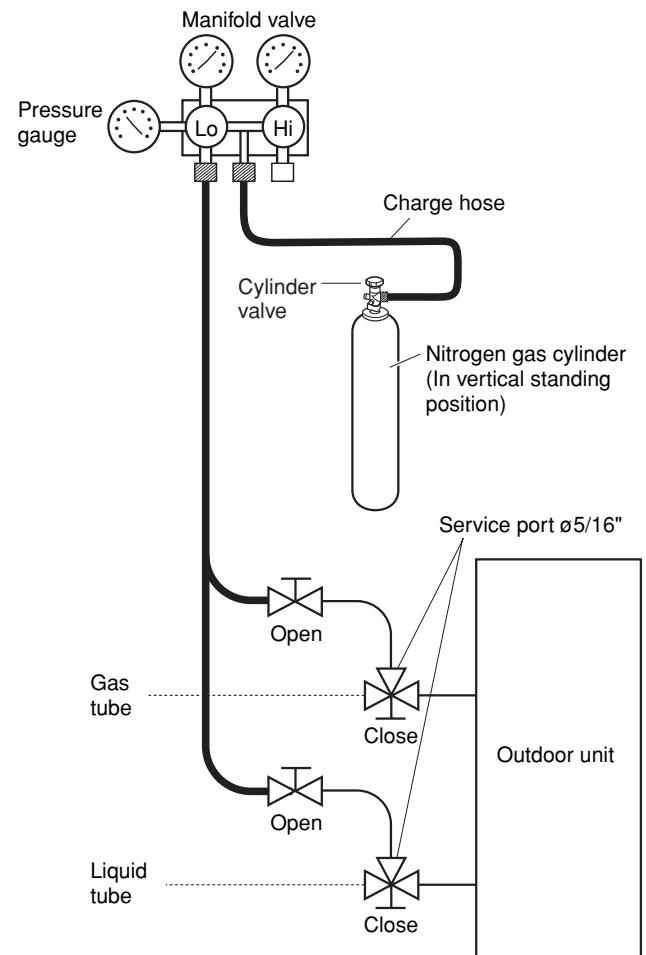

Fig. 7-3

- (3) Do a leak test of all joints of the tubing (both indoor and outdoor) and both gas tube and liquid tube service valves. Bubbles indicate a leak. Wipe off the soap with a clean cloth after the leak test.
- (4) After the system is found to be free of leaks, relieve the nitrogen pressure by loosening the charge hose connector at the nitrogen cylinder. When the system pressure is reduced to normal, disconnect the hose from the cylinder.

Evacuation

- (1) Attach the charge hose end described in the preceding steps to the vacuum pump to evacuate the tubing and indoor unit. Confirm that the “Lo” knob of the manifold valve is open. Then, run the vacuum pump. The operation time for evacuation varies with the tubing length and capacity of the pump. The following table shows the amount of time for evacuation:

Required time for evacuation when 30 gal/h vacuum pump is used	
If tubing length is less than 49 ft.	If tubing length is longer than 49 ft.
45 min. or more	90 min. or more

NOTE

The required time in the above table is calculated based on the assumption that the ideal (or target) vacuum condition is less than -14.7 psig (-755 mmHg, 5 Torr).

- (2) When the desired vacuum is reached, close the “Lo” knob of the manifold valve and turn off the vacuum pump. Confirm that the gauge pressure is under -14.7 psig (-755 mmHg, 5 Torr) after 4 to 5 minutes of vacuum pump operation.

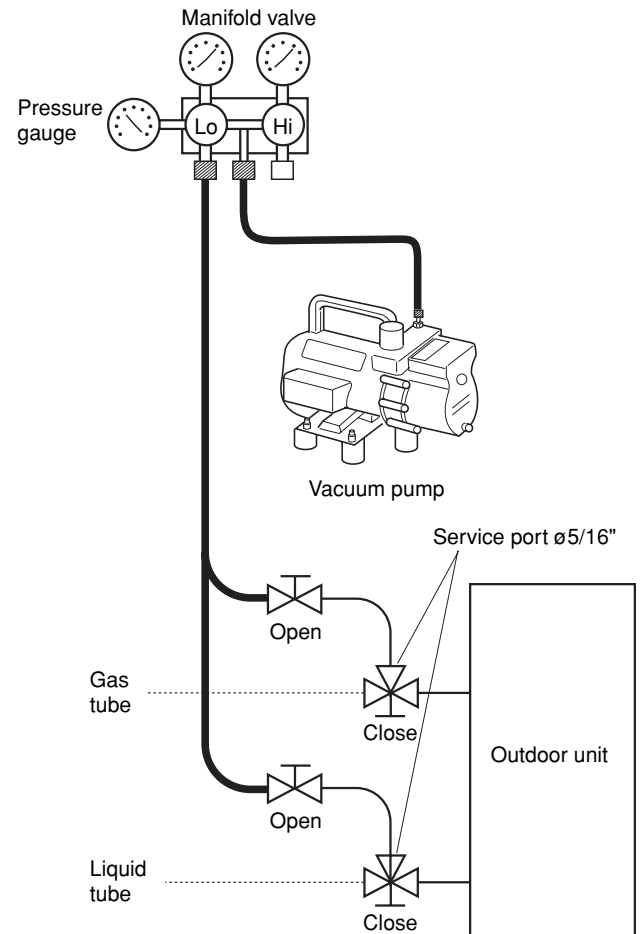

Fig. 7-4



CAUTION

Use a cylinder designed for use with R410A respectively.

Charging additional refrigerant

- Charging additional refrigerant (calculated from the liquid tube length as shown in Section 1-7 “Additional Refrigerant Charge”) using the liquid tube service valve. (Fig. 7-5)
- Use a balance to measure the refrigerant accurately.
- If the additional refrigerant charge amount cannot be charged at once, charge the remaining refrigerant in liquid form by using the gas tube service valve with the system in cooling operation mode at the time of test run. (Fig. 7-6)

Finishing the job

- (1) With a hex wrench, turn the liquid tube service valve stem counter-clockwise to fully open the valve.
- (2) Turn the gas tube service valve stem counter-clockwise to fully open the valve.



CAUTION

To avoid gas from leaking when removing the charge hose, make sure the stem of the gas tube is turned all the way out (“BACK SEAT” position).

- (3) Loosen the charge hose connected to the gas tube service port (for $\varnothing 5/16$ " tube) slightly to release the pressure, then remove the hose.
- (4) Replace the service port cap on the gas tube service port and fasten the cap securely with an monkey spanner or box wrench. This process is very important to prevent gas from leaking from the system.
- (5) Replace the valve caps at both gas tube and liquid tube service valves and fasten them securely.

This completes air purging with a vacuum pump. The air conditioner is now ready for a test run.

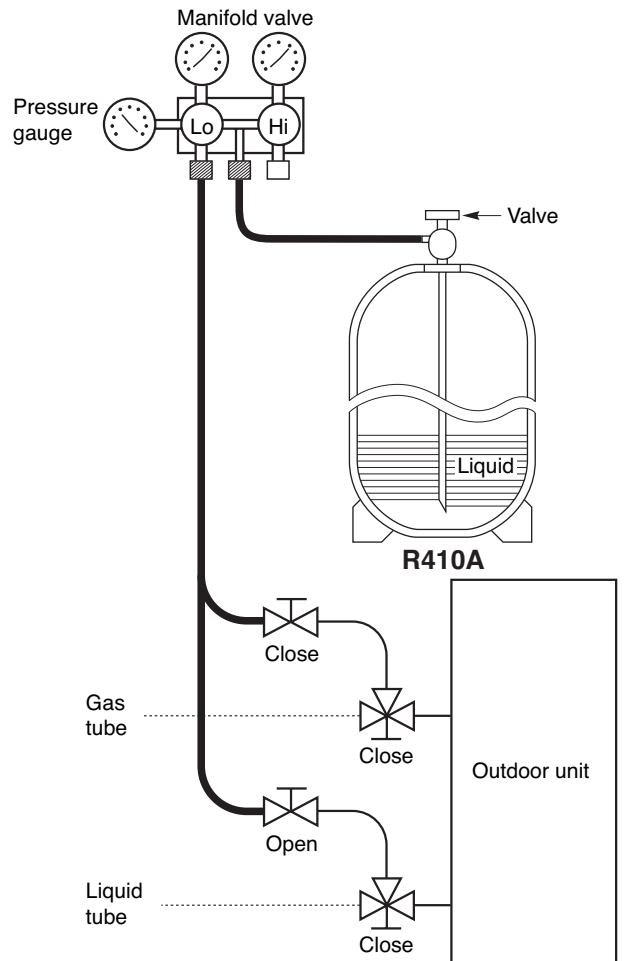

Fig. 7-5

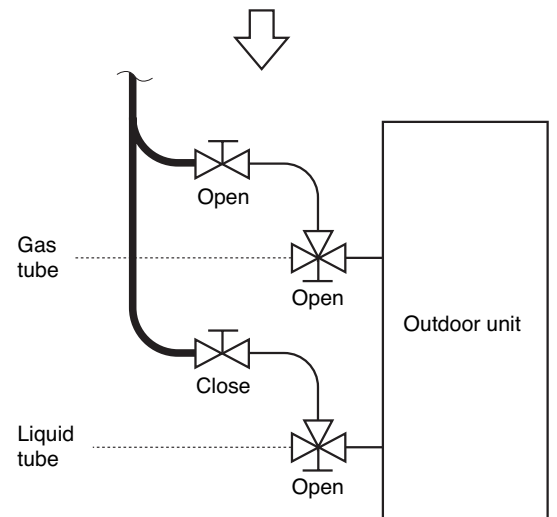

Fig. 7-6

8. TEST RUN

8-1. Preparing for Test Run

- Before attempting to start the air conditioner, check the following.

- (1) All loose matter is removed from the cabinet, especially steel filings, bits of wire, and clips.
- (2) The control wiring is correctly connected and all electrical connections are tight.
- (3) The transportation pads for the indoor fan have been removed. If not, remove them now.
- (4) The power has been connected to the unit for at least 5 hours before starting the compressor. The bottom of the compressor should be warm to the touch and the crankcase heater around the feet of the compressor should be hot to the touch. (Fig. 8-1)

- (5) Both the gas and liquid tube service valves are open. If not, open them now. (Fig. 8-2)

- (6) Request that the customer be present for the trial run.

Explain the contents of the instruction manual, then have the customer actually operate the system.

- (7) Be sure to give the instruction manual and warranty certificate to the customer.

- (8) When replacing the control PCB, be sure to make all the same settings on the new PCB as were in use before replacement.

The existing EEPROM is not changed, and is connected to the new control PCB.

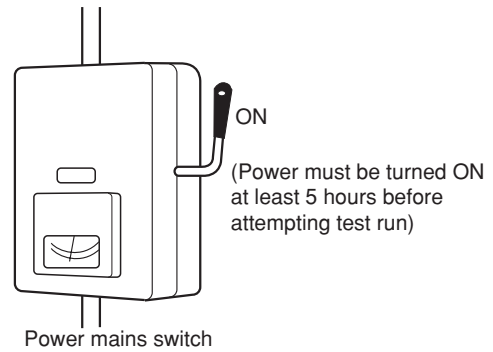

Fig. 8-1

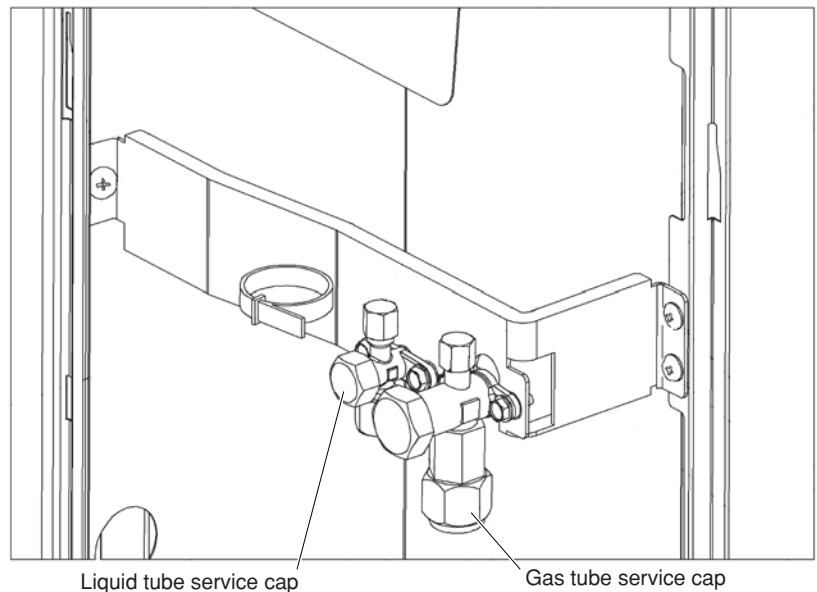

Fig. 8-2

8-2. Test Run Procedure

Items to Check Before the Test Run

1. Turn the remote power switch on at least 5 hours before the test, in order to energize the crank case heater.
 2. Turn the outdoor service valves (2 locations) to the full-open positions.
- Use caution when making the settings. If there are duplicated system addresses, or if the settings for the Nos. of the indoor units are not consistent, an alarm will occur and the system will not start.
 - These settings are not made on the indoor unit PCB.

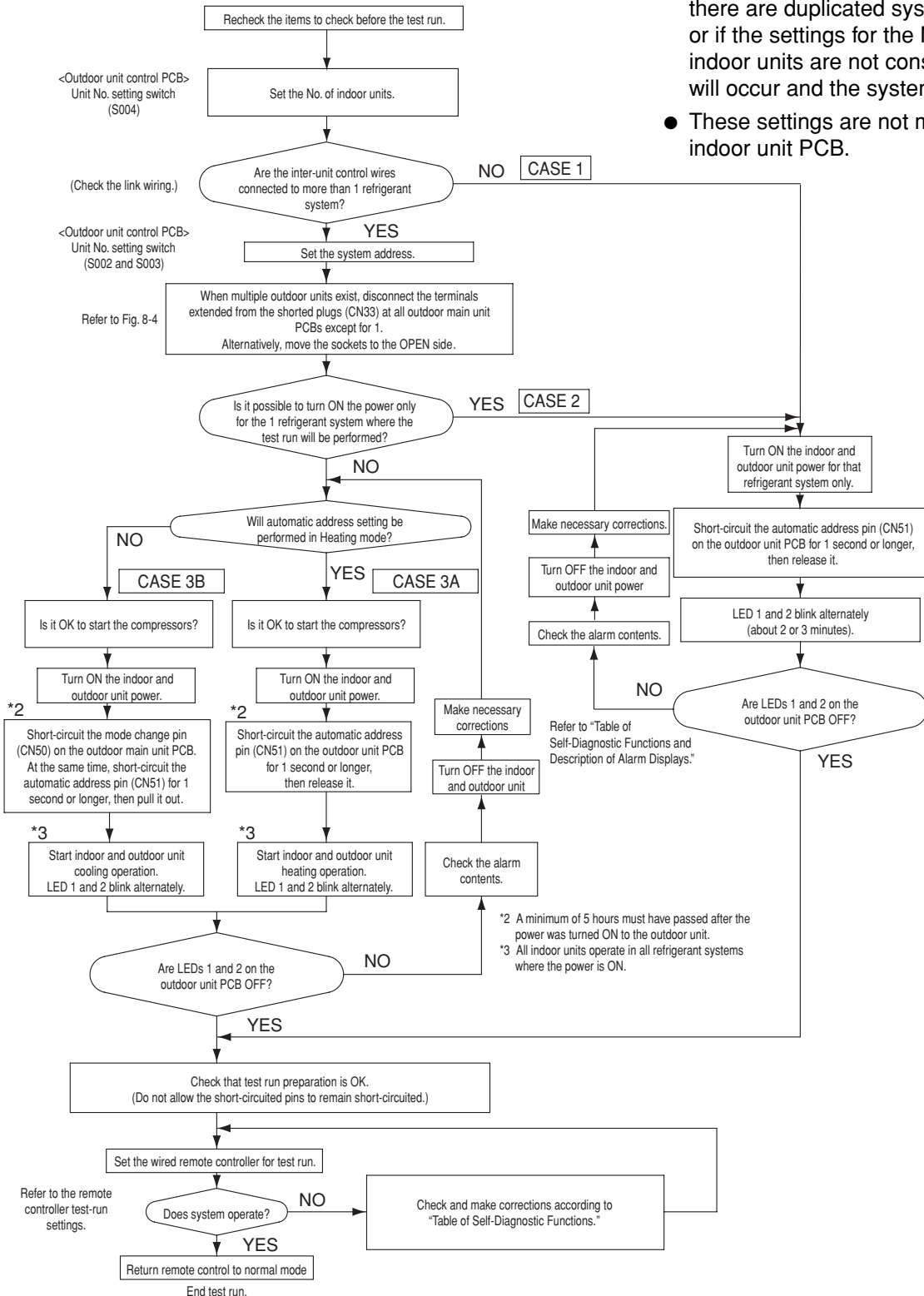













Fig. 8-3

● Examples of the No. of indoor units settings

No. of indoor units	Indoor unit setting (S004) (Rotary switch, red)
1 unit (factory setting)	 Set to 1
2 units	 Set to 2
}	}
9 units	 Set to 9

● Examples of refrigerant circuit (R.C.) address settings (required when link wiring is used)

System address No.	System address (S003) (2P DIP switch, blue)	System address (S002) (Rotary switch, black)
System 1 (factory setting)	Both OFF  ON 1 2 OFF	 Set to 1
System 11	1 ON  ON 1 2 OFF	 Set to 1
System 21	2 ON  ON 1 2 OFF	 Set to 1
System 30	1 & 2 ON  ON 1 2 OFF	 Set to 0

8-4. Auto Address Setting

Basic wiring diagram: Example (1)

- If link wiring is not used
(The inter-unit control wires are not connected to multiple refrigerant systems.)
Indoor unit addresses can be set without operating the compressors.

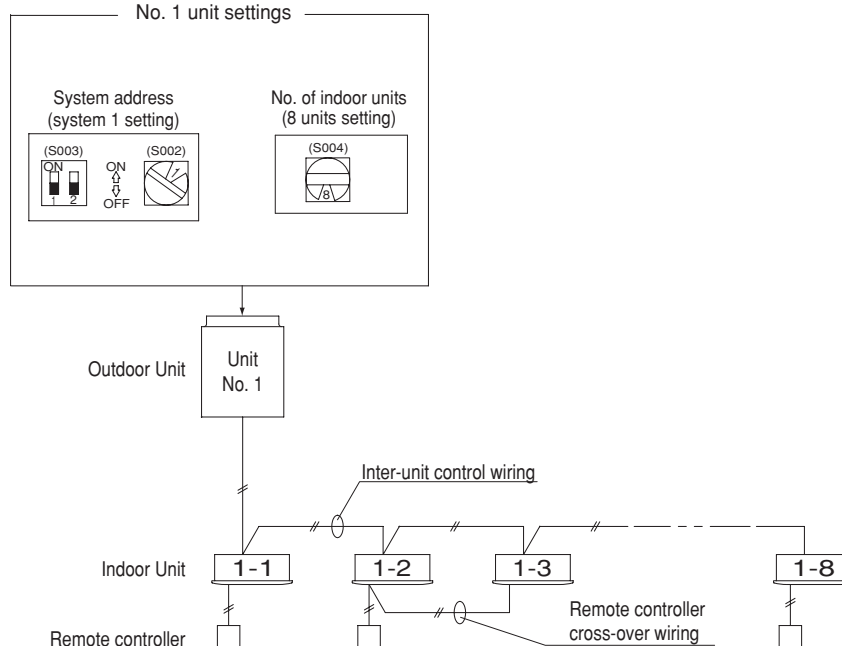
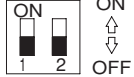

Fig. 8-5

(1) Automatic Address Setting from the Outdoor Unit

1. On the outdoor unit control PCB, check that the system address rotary switch (S002) is set to "1" and that the DIP switch (S003) is set to "0." (These are the settings at the time of factory shipment.)

2. To set the number of indoor units that are connected to the outdoor unit to 8, on the outdoor unit control PCB set the No. of indoor units rotary switch (S004) to "8."
3. Turn ON the power to the indoor and outdoor units.
4. On the outdoor unit control PCB, short-circuit the automatic address pin (CN51) for 1 second or longer, then release it.
 ↓
 (Communication for automatic address setting begins.)
 ↓
 * To cancel, again short-circuit the automatic address pin (CN51) for 1 second or longer, then pull it out. The LED that indicates that automatic address setting is in progress turns OFF and the process is stopped.
 ↓
 (Automatic address setting is completed when LEDs 1 and 2 on the outdoor unit control PCB turn OFF.)
 ↓
5. Operation from the remote controllers is now possible.
 * To perform automatic address setting from the remote controller, perform steps 1 to 3, then use the remote controller and complete automatic address setting.
 Refer to "Automatic Address Setting from the Remote Controller."

Basic wiring diagram: Example (2)

If link wiring is used

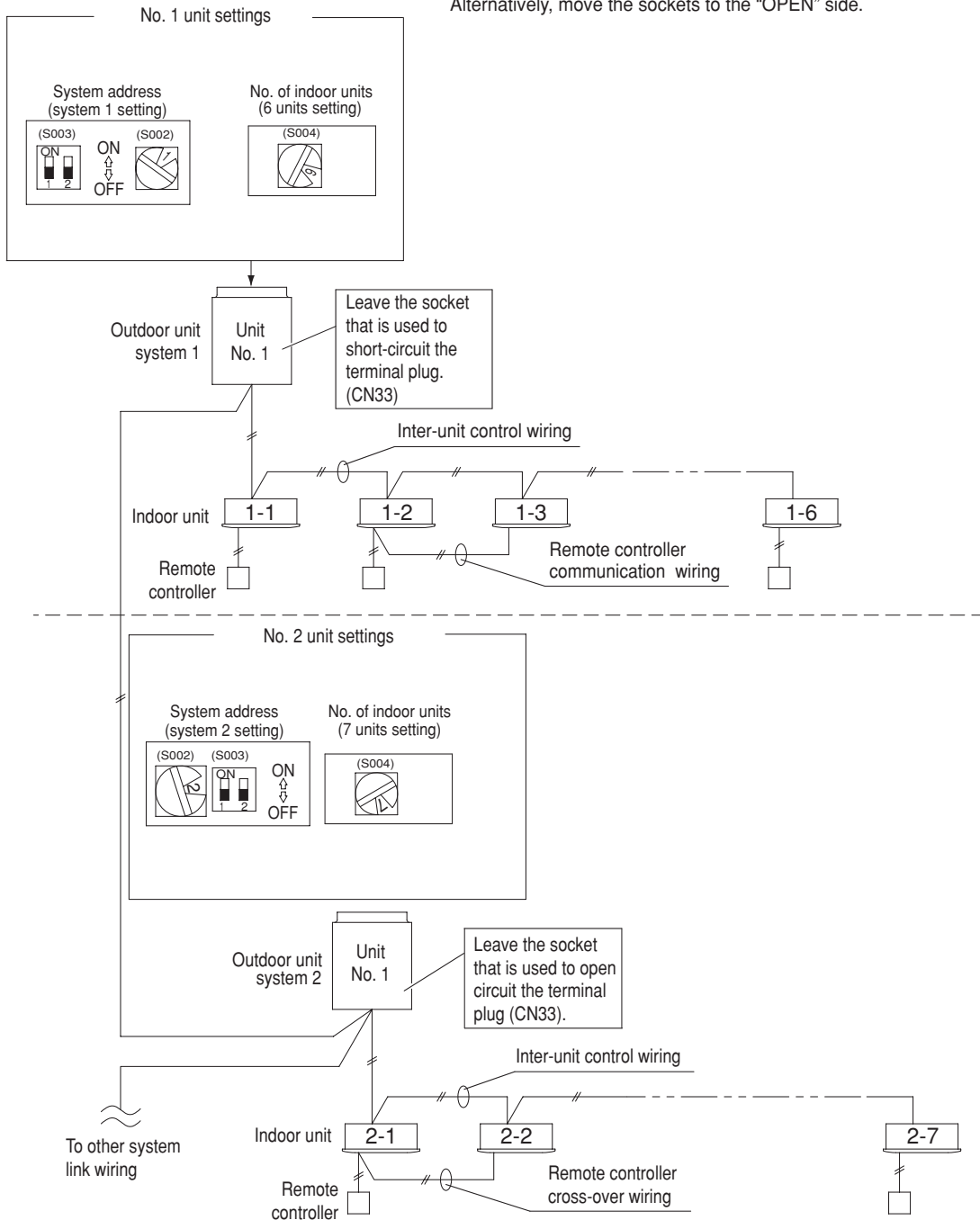
* When multiple outdoor units exist, remove the socket that is used to short-circuit the terminal plug (CN33) from all outdoor unit PCBs except for 1. Alternatively, move the sockets to the "OPEN" side.



Make settings as appropriate for the cases listed below.
(Refer to the instructions on the following pages.)

Indoor and outdoor unit power can be turned ON for each system separately. —> Case 1

Indoor and outdoor unit power cannot be turned ON for each system separately.

Automatic address setting in Heating mode —> Case 2

Automatic address setting in Cooling mode —> Case 3

Fig. 8-6

Case 1 Automatic Address Setting (no compressor operation)

- Indoor and outdoor unit power can be turned ON for each system separately.
Indoor unit addresses can be set without operating the compressors.

Automatic Address Setting from Outdoor Unit

1. On the outdoor unit control PCB, check that the system address rotary switch (S002) is set to “1” and that the DIP switch (S003) is set to “0.”  (These are the settings at the time of factory shipment.)



2. To set the number of indoor units that are connected to the outdoor unit to 6, on the outdoor unit control PCB set the No. of indoor units rotary switch (S004) to “6.”

3. At the outdoor unit where all indoor and outdoor unit power has been turned ON, short-circuit the automatic address pin (CN51) for 1 second or longer, then pull it out.

↓

(Communication for automatic address setting begins.)

↓

* To cancel, again short-circuit the automatic address pin (CN51) for 1 second or longer, then pull it out.
The LED that indicates automatic address setting is in progress turns OFF and the process is stopped.

(Automatic address setting is completed when LEDs 1 and 2 on the outdoor unit control PCB turn OFF.)

↓

4. Next turn the power ON only for the indoor and outdoor units of the next (different) system. Repeat steps 1 – 3 in the same way to complete automatic address settings for all systems.

↓

5. Operation from the remote controllers is now possible.

* To perform automatic address setting from the remote controller, perform steps 1 and 2, then use the remote controller complete automatic address setting.

Refer to “Automatic Address Setting from the Remote Controller.”

Case 2 Automatic Address Setting in Heating Mode

- Indoor and outdoor unit power cannot be turned ON for each system separately.
In the following, automatic setting of indoor unit addresses is not possible if the compressors are not operating.
Therefore perform this process only after completing all refrigerant tubing work.

Automatic Address Setting from Outdoor Unit

1. Perform steps 1 and 2 in the same way as for **Case 1**.
2. Turn the indoor and outdoor unit power ON at all systems.
↓
3. To perform automatic address setting in **Heating mode**, on the outdoor unit control PCB in the refrigerant system where you wish to set the addresses, short-circuit the automatic address pin (CN51) for 1 second or longer, then pull it out.
(Be sure to perform this process for one system at a time. Automatic address settings cannot be performed for more than one system at the same time.)
↓
(Communication for automatic address setting begins, **the compressors turn ON, and automatic address setting in heating mode begins.**)
(All indoor units operate.)
↓
* To cancel, again short-circuit the automatic address pin (CN51) for 1 second or longer, then pull it out.
The LED that indicates automatic address setting is in progress turns OFF and the process is stopped.

(Automatic address setting is completed when the compressors stop and LEDs 1 and 2 on the outdoor unit control PCB turn OFF.)
4. At the outdoor unit in the next (different) system, short-circuit the automatic address pin (CN51) for 1 second or longer, then pull it out.
↓
(Repeat the same steps to complete automatic address setting for all units.)
↓
5. Operation from the remote controllers is now possible.

* To perform automatic address setting from the remote controller, perform steps 1 and 2, then use the remote controller complete automatic address setting.
Refer to "Automatic Address Setting from the Remote Controller."

Case 3 Automatic Address Setting in Cooling Mode

- Indoor and outdoor unit power cannot be turned ON for each system separately.
In the following, automatic setting of indoor unit addresses is not possible if the compressors are not operating.
Therefore perform this process only after completing all refrigerant tubing work.
Automatic address setting can be performed during Cooling operation.

Automatic Address Setting from Outdoor Unit

1. Perform steps 1 and 2 in the same way as for **Case 1**.
2. Turn the indoor and outdoor unit power ON at all systems.
↓
3. To perform automatic address setting in **Cooling mode**, on the outdoor unit control PCB in the refrigerant system where you wish to set the addresses, short-circuit the mode change 2P pin (CN50). At the same time, short-circuit the automatic address pin (CN51) for 1 second or longer, then pull it out. (Be sure to perform this process for one system at a time. Automatic address settings cannot be performed for more than one system at the same time.)
↓

(Communication for automatic address setting begins, **the compressors turn ON, and automatic address setting in Cooling mode begins.**)

(All indoor units operate.)

- ↓ * To cancel, again short-circuit the automatic address pin (CN51) for 1 second or longer, then pull it out.
The LED that indicates automatic address setting is in progress turns OFF and the process is stopped.

(Automatic address setting is completed when the compressors stop and LEDs 1 and 2 on the outdoor unit control PCB turn OFF.)

4. At the outdoor unit in the next (different) system, short-circuit the automatic address pin (CN51) for 1 second or longer, then pull it out.
↓

(Repeat the same steps to complete automatic address setting for all units.)
↓







5. Operation from the remote controllers is now possible.

* Automatic address setting in Cooling mode cannot be done from the remote controller.

Automatic Address Setting from the Remote Controller

Selecting each refrigerant system individually for automatic address setting

---Automatic address setting for each system: Item code "A1"

- Press the remote controller timer time  button and  button at the same time. (Press and hold for 4 seconds or longer.)
- Next, press either the temperature setting  or  button.
(Check that the item code is "A1.")
- Use either the  or  button to set the system No. to perform automatic address setting.
- Then press the  button.
(Automatic address setting for one refrigerant system begins.)
(When automatic address setting for one system is completed, the system returns to normal stopped status.) <Approximately 4 – 5 minutes is required.>
(During automatic address setting, "SETTING" is displayed on the remote controller. This message disappears when automatic address setting is completed.)
- Repeat the same steps to perform automatic address setting for each successive system.

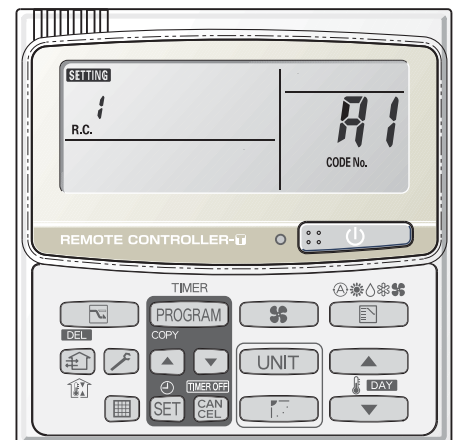

Display during automatic address setting

- On outdoor unit PCB

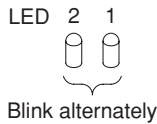

* Do not short-circuit the automatic address setting pin (CN51) again while automatic address setting is in progress. Doing so will cancel the setting operation and will cause LEDs 1 and 2 to turn OFF.

* When automatic address setting has been successfully completed, both LEDs 1 and 2 turn OFF.

* LED 1 is D042. LED 2 is D043.

* If automatic address setting is not completed successfully, refer to the table below and correct the problem. Then perform automatic address setting again.

- Display details of LEDs 1 and 2 on the outdoor unit control PCB

(☀ : ON ✨ : Blinking ● : OFF)

LED 1	LED 2	Display meaning
☀	☀	After the power is turned ON (and automatic address setting is not in progress), no communication with the indoor units in that system is possible.
●	☀	After the power is turned ON (and automatic address setting is not in progress), 1 or more indoor units are confirmed in that system; however, the number of indoor units does not match the number that was set.
✨	✨	Automatic address setting is in progress.
●	●	Automatic address setting completed.
☀	☀	At time of automatic address setting, the number of indoor units did not match the number that was set. ⚠ (when indoor units are operating) indication appears on the display.
✨	✨	Refer to Table of Self-Diagnostic Functions and Description of Alarm Displays.

Note: ⚠ indicates that the solenoid is fused or that there is a CT (current detection circuit) failure (current is detected when the compressor is OFF).

- Remote controller display during automatic setting

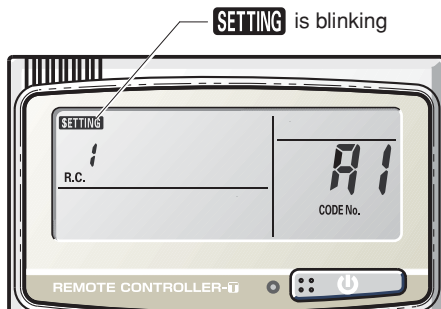

Request concerning recording the indoor/outdoor unit combination Nos.

After automatic address setting has been completed, be sure to record them for future reference.

List the outdoor unit system address and the addresses of the indoor units in that system in an easily visible location (next to the nameplate), using a permanent marking pen or similar means that cannot be erased easily.



Example: (Outdoor) 1 – (Indoor) 1-1, 1-2, 1-3... (Outdoor) 2 – (Indoor) 2-1, 2-2, 2-3...

These numbers are necessary for later maintenance. Please be sure to indicate them.





Checking the indoor unit addresses

Use the remote controller to check the indoor unit address.

<If 1 indoor unit is connected to 1 remote controller>

1. Press and hold the  button and  button for 4 seconds or longer (simple settings mode).
2. The address is displayed for the indoor unit that is connected to the remote controller.
(Only the address of the indoor unit that is connected to the remote controller can be checked.)
3. Press the  button again to return to normal remote controller mode.

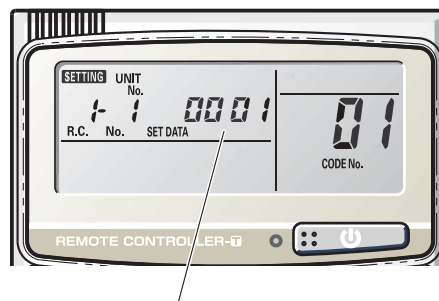

<If multiple indoor units are connected to 1 remote controller (group control)>

1. Press and hold the  button and  button for 4 seconds or longer (simple settings mode).
2. "ALL" is displayed on the remote controller.
3. Next, press the  button.
4. The address is displayed for 1 of the indoor units which is connected to the remote controller. Check that the fan of that indoor unit starts and that air is discharged.
5. Press the  button again and check the address of each indoor unit in sequence.
6. Press the  button again to return to normal remote controller mode.



Number changes to indicate which indoor unit is currently selected.

Remote Controller Test Run Settings

1. Press the remote controller  button for 4 seconds or longer. Then press the  button.
 - "TEST" appears on the LCD display while the test run is in progress.
 - The temperature cannot be adjusted when in Test Run mode.
(This mode places a heavy load on the machines. Therefore use it only when performing the test run.)
 2. The test run can be performed using the HEAT, COOL, or FAN operation modes.
Note: The outdoor units will not operate for approximately 3 minutes after the power is turned ON and after operation is stopped.
 3. If correct operation is not possible, a code is displayed on the remote controller display.
(Refer to "7-6. Meaning of Alarm Messages" and correct the problem.)
 4. After the test run is completed, press the  button again. Check that "TEST" disappears from the remote controller display.
(To prevent continuous test runs, this remote controller includes a timer function that cancels the test run after 60 minutes.)
- * If the test run is performed using the wired remote controller, operation is possible even if the cassette-type ceiling panel has not been installed. ("P09" display does not occur.)

8-5. Caution for Pump Down

Pump down means refrigerant gas in the system is returned to the outdoor unit. Pump down is used when the unit is to be moved, or before servicing the refrigerant circuit.



CAUTION

- This outdoor unit cannot collect more than the rated refrigerant amount as shown by the nameplate on the back.
- If the amount of refrigerant is more than that recommended, do not conduct pump down. In this case use another refrigerant collecting system.

8-6. Meaning of Alarm Messages

Table of Self-Diagnostics Functions and Description of Alarm Displays

Alarm messages are indicated by the blinking of LED 1 and 2 (D72, D75) on the outdoor unit PCB. They are also displayed on the wired remote controller.

- Viewing the LED 1 and 2 (D72 and D75) alarm displays

LED 1	LED 2	Alarm contents
☼	☼	Alarm display
Alternating		LED 1 blinks M times, then LED 2 blinks N times. The cycle then repeats. M = 2: P alarm 3: H alarm 4: E alarm 5: F alarm 6: L alarm N = Alarm No. Example: LED 1 blinks 2 times, then LED 2 blinks 17 times. The cycle then repeats. Alarm is "P17."

(☼ : Blinking)

Possible cause of malfunction			Alarm message
Serial communication errors Mis-setting	Remote controller is detecting error signal from indoor unit.	Error in receiving serial communication signal. (Signal from main indoor unit in case of group control) Ex: Auto address is not completed.	<E01>
		Error in transmitting serial communication signal.	<E02>
	Indoor unit is detecting error signal from remote controller (and system controller).		<<E03>>
	Indoor unit is detecting error signal from outdoor unit.	Error in receiving serial communication signal. When turning on the power supply, the number of connected indoor units does not correspond to the number set. (Except R.C. address is "0.")	E04
		Error of the outdoor unit in receiving serial communication signal from the indoor unit.	<E06>
Improper setting of indoor unit or remote controller.		Indoor unit address setting is duplicated.	E08
		Remote controller address connector (RCU. ADR) is duplicated. (Duplication of main remote controller)	<<E09>>
During auto. address setting, number of connected units does not correspond to number set.		Starting auto. address setting is prohibited.	E12
		This alarm message shows that the auto address connector CN100 is shorted while other RC line is executing auto address operation.	E15
When turning on the power supply, number of connected units does not correspond to number set. (Except R.C. address is "0.")		Error in auto. address setting. (Number of connected indoor units is less than the number set)	E16
		Error in auto. address setting. (Number of connected indoor units is more than the number set)	E20
		No indoor unit is connected during auto. address setting.	E25
		Error of outdoor unit address setting.	E18
Indoor unit communication error of group control wiring.		Error of main indoor unit in receiving serial communication signal from sub indoor units.	

Continued

Possible cause of malfunction			Alarm message		
Serial communication errors Mis-setting	Improper setting.	This alarm message shows when the indoor unit for multiple-use is not connected to the outdoor unit.	L02		
		Duplication of main indoor unit address setting in group control.	<<L03>		
		Duplication of outdoor R.C. address setting.	L04		
		There are 2 or more indoor units controllers which have operation mode priority in 1 refrigerant circuit.	Priority set remote controller	L05	
			Non-priority set remote controller	L06	
		Group control wiring is connected to individual control indoor unit.	L07		
		Indoor unit address is not set.	L08		
		Capacity code of indoor unit is not set.	<<L09>>		
		Capacity code of outdoor unit is not set.	L10		
		Mis-matched connection of outdoor units which have different kinds of refrigerant.	L17		
		4-way valve operation failure	L18		
Activation of protective device	Protective device in indoor unit is activated.	Thermal protector in indoor unit fan motor is activated.	<<P01>>		
		Improper wiring connections of ceiling panel.	<<P09>>		
		Float switch is activated.	<<P10>>		
		Operation of protective function of fan inverter.	P12		
		O ₂ sensor (detects low oxygen level) activated.	P14		
	Protective device in outdoor unit is activated.	Compressor thermal protector is activated. Power supply voltage is unusual. (The voltage is more than 260 V or less than 160 V between L1 and L2 phase.)	P02		
		Incorrect discharge temperature.	P03		
		High pressure switch is activated.	P04		
		Detective phase (3-phase outdoor unit only)	P05		
		Compressor running failure resulting from missing phase in the compressor wiring, etc. (Start failure not caused by IPM or no gas.)	P16		
		Outdoor unit fan motor is unusual.	P22		
		Overcurrent at time of compressor runs more than 80Hz (DCCT secondary current or ACCT primary current is detected at a time other than when IPM has tripped.)	P26		
		IPM trip (IPM current or temperature)	H31		
		Inverter for compressor is unusual. (DC compressor does not operate.)	P29		
		Thermistor fault	Indoor thermistor is either open or damaged.	Indoor coil temp. sensor (E1)	<<F01>>
				Indoor coil temp. sensor (E2)	<<F02>>
				Indoor coil temp. sensor (E3)	<<F03>>
				Indoor suction air (room) temp. sensor (TA)	<<F10>>
				Indoor discharge air temp. sensor (BL)	<<F11>>
Outdoor thermistor is either open or damaged.	Compressor discharge sensor (TD)		F04		
	Outdoor No. 1 coil liquid temp. sensor (C1)		F07		
	Outdoor air temp. sensor (TO)		F08		
	Compressor suction port temperature sensor (TS)		F12		
	High pressure sensor		F16		
EEPROM on indoor unit PCB failure			F29		
Protective device for compressor is activated	Protective device for compressor No. 1 is activated.	EEPROM on the outdoor unit PCB is a failure.	F31		
		Current is not detected when comp. is ON.	H03		

9. APPENDIX

9-1. 4-Way Air Discharge Semi-Concealed Type (X Type)

■ NAME OF PARTS

X type (4-WAY)

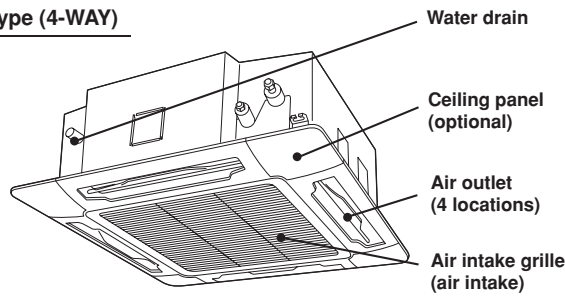

■ CARE AND CLEANING



WARNING

1. For safety, be sure to turn the air conditioner off and also to disconnect the power before cleaning.
2. Do not pour water on the indoor unit to clean it. This will damage the internal components and cause an electric shock hazard.

Air intake and outlet side (Indoor unit)

Clean the air intake and outlet side of the indoor unit with a vacuum cleaner brush, or wipe them with a clean, soft cloth.

If these parts are stained, use a clean cloth moistened with a mild liquid detergent. When cleaning the air outlet side, be careful not to force the vanes out of place.



CAUTION

1. Never use solvents or harsh chemicals when cleaning the indoor unit. Do not wipe plastic parts using very hot water.
2. Some metal edges and the fins are sharp and may cause injury if handled improperly; be especially careful when you clean these parts.
3. The internal coil and other components of the outdoor unit must be cleaned every year. Consult your dealer or service center.

Air filter

The air filter collects dust and other particles from the air and should be cleaned at regular intervals as indicated in the table below or when the filter indication () on the display of the remote control unit (wired type) shows that the filter needs cleaning. If the filter gets blocked, the efficiency of the air conditioner drops greatly.

Type	Period
X	6 months

NOTE

The frequency with which the filter should be cleaned depends on the environment in which the unit is used.

<How to clean the filter>

1. Remove the air filter from the air intake grille.
2. Use a vacuum cleaner to remove light dust. If there is sticky dust on the filter, wash the filter in lukewarm, soapy water, rinse it in clean water, and dry it.

<How to remove the filter>

1. Use a screwdriver to remove the bolt screw on each side for the two latches. (Be sure to reattach the two bolt screws after cleaning.)
2. Press on the two latches of the air intake grille with your thumbs in the direction of the arrow to open the grille.
3. Open the air intake grille downward.



CAUTION

- When cleaning the air filter, never remove the safety chain. If it is necessary to remove it for servicing and maintenance inside, be sure to reinstall the safety chain securely (hook on the grille side) after the work.
- When the filter has been removed, rotating parts (such as the fan), electrically charged areas, etc. will be exposed in the unit's opening. Bear in mind the dangers that these parts and areas pose, and proceed with the work carefully.

- Remove the air filter attached to the air intake grille.

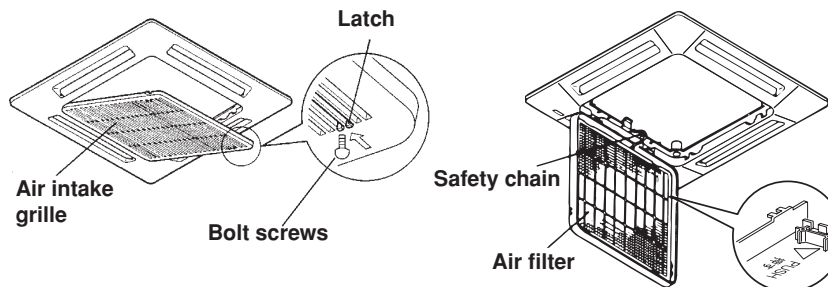

CAUTION

- Certain metal edges and the condenser fins are sharp and may cause injury if handled improperly; special care should be taken when you clean these parts.
- Periodically check the outdoor unit to see if the air outlet or air intake is clogged with dirt or soot.
- The internal coil and other components of the outdoor unit must also be cleaned periodically. Consult your dealer or service center.

Care: After a prolonged idle period Check the indoor and outdoor unit air intakes and outlets for blockage; if there is a blockage, remove it.

- Care: Before a prolonged idle period**
- Operate the fan for half a day to dry out the inside.
 - Disconnect the power supply and also turn off the circuit breaker.
 - Clean the air filter and replace it in its original position.
 - Outdoor unit internal components must be checked and cleaned periodically. Contact your local dealer for this service.

■ TROUBLESHOOTING

If your air conditioner does not work properly, first check the following points before requesting service. If it still does not work properly, contact your dealer or a service center.

Trouble	Possible Cause	Remedy
Air conditioner does not run at all	<ol style="list-style-type: none"> Power failure. Leakage circuit breaker has tripped. Line voltage is too low. Operation button is turned off. The wired remote control unit or heat pump is malfunctioning. (The inspection mark \triangle and the letters E, F, H, L, P in combination with numbers appear on the LCD of the wired remote control unit.) 	<ol style="list-style-type: none"> After a power outage, press ON/OFF operation button on the wired remote control unit. Contact service center. Consult your electrician or dealer. Press the button again. Consult your dealer.
Compressor runs but soon stops	<ol style="list-style-type: none"> Obstruction in front of condenser coil 	<ol style="list-style-type: none"> Remove obstruction
Poor cooling (or heating) performance	<ol style="list-style-type: none"> Dirty or clogged air filter. Heat source or many people in room. Doors and/or windows are open. Obstacle near air intake or air discharge port. Thermostat is set too high for cooling (or too low for heating). (Defrosting system does not work.) 	<ol style="list-style-type: none"> Clean air filter to improve the airflow. Eliminate heat source if possible. Shut them to keep the heat (or cold) out. Remove it to ensure good airflow. Set the temperature lower (or higher). (Consult your dealer.)

■ Tips for Energy Saving

- Avoid**
- Do not block the air intake and outlet of the unit. If either is obstructed, the unit will not work well, and may be damaged.**
 - Do not let direct sunlight into the room. Use sunshades, blinds or curtains. If the walls and ceiling of the room are warmed by the sun, it will take longer to cool the room.
- Do**
- Always try to keep the air filter clean. (Refer to “Care and Cleaning.”) A clogged filter will impair the performance of the unit.
 - To prevent conditioned air from escaping, keep windows, doors and any other openings closed.

NOTE

Should the power fail while the unit is running

If the power supply for this unit is temporarily cut off, the unit will automatically resume operation once power is restored using the same settings before the power was interrupted.

9-2. 1-Way Air Discharge Semi-Concealed Type (A Type)

NAME OF PARTS

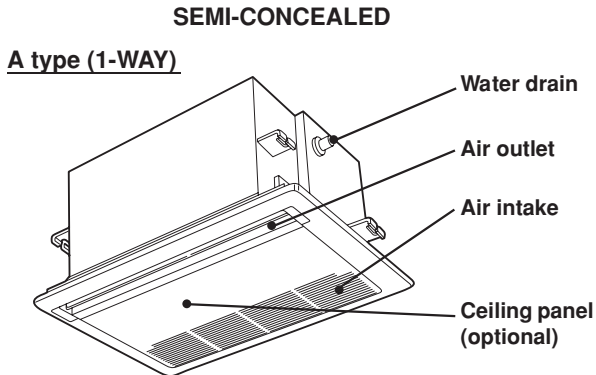

CARE AND CLEANING



WARNING

1. For safety, be sure to turn the air conditioner off and also to disconnect the power before cleaning.
2. Do not pour water on the indoor unit to clean it. This will damage the internal components and cause an electric shock hazard.

Air intake and outlet side (Indoor unit)

Clean the air intake and outlet side of the indoor unit with a vacuum cleaner brush, or wipe them with a clean, soft cloth.

If these parts are stained, use a clean cloth moistened with a mild liquid detergent. When cleaning the air outlet side, be careful not to force the vanes out of place.



CAUTION

1. Never use solvents or harsh chemicals when cleaning the indoor unit. Do not wipe plastic parts using very hot water.
2. Some metal edges and the fins are sharp and may cause injury if handled improperly; be especially careful when you clean these parts.
3. The internal coil and other components of the outdoor unit must be cleaned every year. Consult your dealer or service center.

Air filter

The air filter collects dust and other particles from the air and should be cleaned at regular intervals as indicated in the table below or when the filter indication () on the display of the remote control unit (wired type) shows that the filter needs cleaning. If the filter gets blocked, the efficiency of the air conditioner drops greatly.

Type	A
Period	2 weeks

NOTE

The frequency with which the filter should be cleaned depends on the environment in which the unit is used.

<How to clean the filter>

1. Remove the air filter from the air intake grille.
2. Use a vacuum cleaner to remove light dust. If there is sticky dust on the filter, wash the filter in lukewarm, soapy water, rinse it in clean water, and dry it.

<How to remove the filter>

1-way air discharge semi-concealed type (A):

1. Take hold of the finger-hold on the air intake grille and press it to the rear, and the grille will open downward.
2. Take hold of the finger-hold on the air filter, pull it toward you.

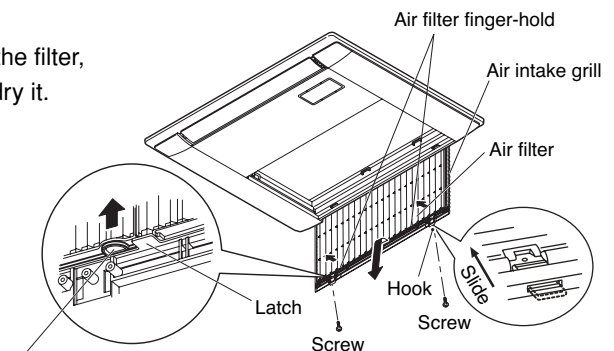

*Take hold of the finger-hold on the air filter, pull it toward you.

Outdoor unit



CAUTION

1. **Certain metal edges and the condenser fins are sharp and may cause injury if handled improperly; special care should be taken when you clean these parts.**
2. **Periodically check the outdoor unit to see if the air outlet or air intake is clogged with dirt or soot.**
3. **The internal coil and other components of the outdoor unit must also be cleaned periodically. Consult your dealer or service center.**

Care: After a prolonged idle period Check the indoor and outdoor unit air intakes and outlets for blockage; if there is a blockage, remove it.

Care: Before a prolonged idle period

- Operate the fan for half a day to dry out the inside.
- Disconnect the power supply and also turn off the circuit breaker.
- Clean the air filter and replace it in its original position.
- Outdoor unit internal components must be checked and cleaned periodically. Contact your local dealer for this service.

■ TROUBLESHOOTING

If your air conditioner does not work properly, first check the following points before requesting service. If it still does not work properly, contact your dealer or a service center.

Trouble	Possible Cause	Remedy
Air conditioner does not run at all	<ol style="list-style-type: none"> 1. Power failure. 2. Leakage circuit breaker has tripped. 3. Line voltage is too low. 4. Operation button is turned off. 5. The wired remote control unit or heat pump is malfunctioning. (The inspection mark and the letters E, F, H, L, P in combination with numbers appear on the LCD of the wired remote control unit.) 	<ol style="list-style-type: none"> 1. After a power outage, press ON/OFF operation button on the wired remote control unit. 2. Contact service center. 3. Consult your electrician or dealer. 4. Press the button again. 5. Consult your dealer.
Compressor runs but soon stops	<ol style="list-style-type: none"> 1. Obstruction in front of condenser coil 	<ol style="list-style-type: none"> 1. Remove obstruction
Poor cooling (or heating) performance	<ol style="list-style-type: none"> 1. Dirty or clogged air filter. 2. Heat source or many people in room. 3. Doors and/or windows are open. 4. Obstacle near air intake or air discharge port. 5. Thermostat is set too high for cooling (or too low for heating). 6. (Defrosting system does not work.) 	<ol style="list-style-type: none"> 1. Clean air filter to improve the airflow. 2. Eliminate heat source if possible. 3. Shut them to keep the heat (or cold) out. 4. Remove it to ensure good airflow. 5. Set the temperature lower (or higher). 6. (Consult your dealer.)

■ Tips for Energy Saving

- Avoid**
- **Do not block the air intake and outlet of the unit. If either is obstructed, the unit will not work well, and may be damaged.**
 - Do not let direct sunlight into the room. Use sunshades, blinds or curtains. If the walls and ceiling of the room are warmed by the sun, it will take longer to cool the room.
- Do**
- Always try to keep the air filter clean. (Refer to “Care and Cleaning.”) A clogged filter will impair the performance of the unit.
 - To prevent conditioned air from escaping, keep windows, doors and any other openings closed.

NOTE

Should the power fail while the unit is running

If the power supply for this unit is temporarily cut off, the unit will automatically resume operation once power is restored using the same settings before the power was interrupted.

9-3. Concealed Duct (High-Static Pressure) Type (U, D Type)

■ NAME OF PARTS

CONCEALED DUCT
U type (standard static pressure)

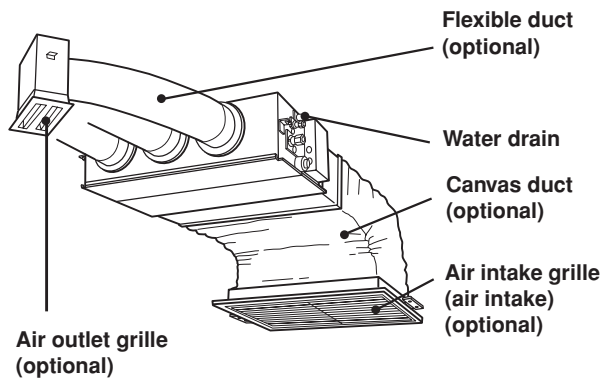

CONCEALED DUCT
D type (high static pressure)

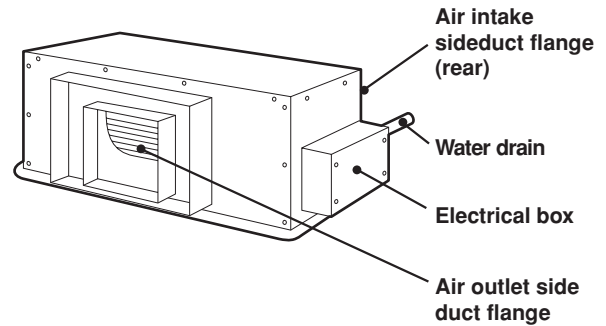

■ CARE AND CLEANING



WARNING

1. For safety, be sure to turn the air conditioner off and also to disconnect the power before cleaning.
2. Do not pour water on the indoor unit to clean it. This will damage the internal components and cause an electric shock hazard.

Air intake and outlet side (Indoor unit)

Clean the air intake and outlet side of the indoor unit with a vacuum cleaner brush, or wipe them with a clean, soft cloth.

If these parts are stained, use a clean cloth moistened with a mild liquid detergent. When cleaning the air outlet side, be careful not to force the vanes out of place.



CAUTION

1. Never use solvents or harsh chemicals when cleaning the indoor unit. Do not wipe plastic parts using very hot water.
2. Some metal edges and the fins are sharp and may cause injury if handled improperly; be especially careful when you clean these parts.
3. The internal coil and other components of the outdoor unit must be cleaned every year. Consult your dealer or service center.

Type	Period
U, D*	(Depends on filter specifications)

***Concealed duct type (U, D):**

An air filter is not provided with this air conditioner at the time of shipment. To get clean air and to extend the service life of the air conditioner, an air filter must be installed in the air intake. For installation and cleaning the air filter, consult your dealer or service center.

NOTE

The frequency with which the filter should be cleaned depends on the environment in which the unit is used.

<How to clean the filter>

1. Remove the air filter from the air intake grille.
2. Use a vacuum cleaner to remove light dust. If there is sticky dust on the filter, wash the filter in lukewarm, soapy water, rinse it in clean water, and dry it.

U
D

■ TROUBLESHOOTING

If your air conditioner does not work properly, first check the following points before requesting service. If it still does not work properly, contact your dealer or a service center.

Trouble	Possible Cause	Remedy
Air conditioner does not run at all	<ol style="list-style-type: none"> 1. Power failure. 2. Leakage circuit breaker has tripped. 3. Line voltage is too low. 4. Operation button is turned off. 5. The wired remote control unit or heat pump is malfunctioning. (The inspection mark \triangle and the letters E, F, H, L, P in combination with numbers appear on the LCD of the wired remote control unit.) 	<ol style="list-style-type: none"> 1. After a power outage, press ON/OFF operation button on the wired remote control unit. 2. Contact service center. 3. Consult your electrician or dealer. 4. Press the button again. 5. Consult your dealer.
Compressor runs but soon stops	<ol style="list-style-type: none"> 1. Obstruction in front of condenser coil 	<ol style="list-style-type: none"> 1. Remove obstruction
Poor cooling (or heating) performance	<ol style="list-style-type: none"> 1. Dirty or clogged air filter. 2. Heat source or many people in room. 3. Doors and/or windows are open. 4. Obstacle near air intake or air discharge port. 5. Thermostat is set too high for cooling (or too low for heating). 6. (Defrosting system does not work.) 	<ol style="list-style-type: none"> 1. Clean air filter to improve the airflow. 2. Eliminate heat source if possible. 3. Shut them to keep the heat (or cold) out. 4. Remove it to ensure good airflow. 5. Set the temperature lower (or higher). 6. (Consult your dealer.)

■ Tips for Energy Saving

- Avoid**
- **Do not block the air intake and outlet of the unit. If either is obstructed, the unit will not work well, and may be damaged.**
 - Do not let direct sunlight into the room. Use sunshades, blinds or curtains. If the walls and ceiling of the room are warmed by the sun, it will take longer to cool the room.
- Do**
- Always try to keep the air filter clean. (Refer to “Care and Cleaning.”) A clogged filter will impair the performance of the unit.
 - To prevent conditioned air from escaping, keep windows, doors and any other openings closed.

NOTE

Should the power fail while the unit is running

If the power supply for this unit is temporarily cut off, the unit will automatically resume operation once power is restored using the same settings before the power was interrupted.

9-4. Ceiling-Mounted Type (T Type)

■ NAME OF PARTS

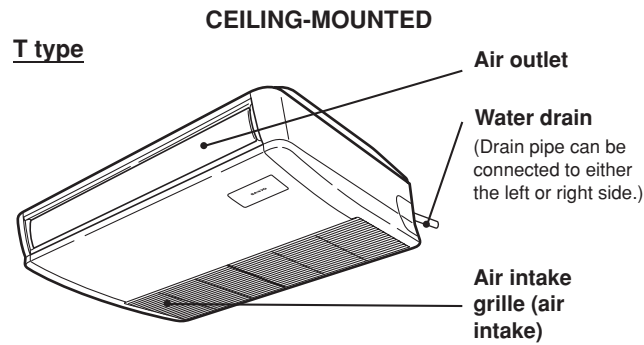

■ CARE AND CLEANING



WARNING

1. For safety, be sure to turn the air conditioner off and also to disconnect the power before cleaning.
2. Do not pour water on the indoor unit to clean it. This will damage the internal components and cause an electric shock hazard.

Air intake and outlet side (Indoor unit)

Clean the air intake and outlet side of the indoor unit with a vacuum cleaner brush, or wipe them with a clean, soft cloth.

If these parts are stained, use a clean cloth moistened with a mild liquid detergent. When cleaning the air outlet side, be careful not to force the vanes out of place.



CAUTION

1. Never use solvents or harsh chemicals when cleaning the indoor unit. Do not wipe plastic parts using very hot water.
2. Some metal edges and the fins are sharp and may cause injury if handled improperly; be especially careful when you clean these parts.
3. The internal coil and other components of the outdoor unit must be cleaned every year. Consult your dealer or service center.

Air filter

The air filter collects dust and other particles from the air and should be cleaned at regular intervals as indicated in the table below or when the filter indication () on the display of the remote control unit (wired type) shows that the filter needs cleaning. If the filter gets blocked, the efficiency of the air conditioner drops greatly.

Type	Period
T	2 weeks

NOTE

The frequency with which the filter should be cleaned depends on the environment in which the unit is used.

<How to clean the filter>

1. Remove the air filter from the air intake grille.
2. Use a vacuum cleaner to remove light dust. If there is sticky dust on the filter, wash the filter in lukewarm, soapy water, rinse it in clean water, and dry it.

<How to remove the filter>

1. Take hold of the finger-hold on the air intake grille and press it to the rear, and the grille will open downward.
2. Take hold of the finger-hold on the air filter, pull it toward you.

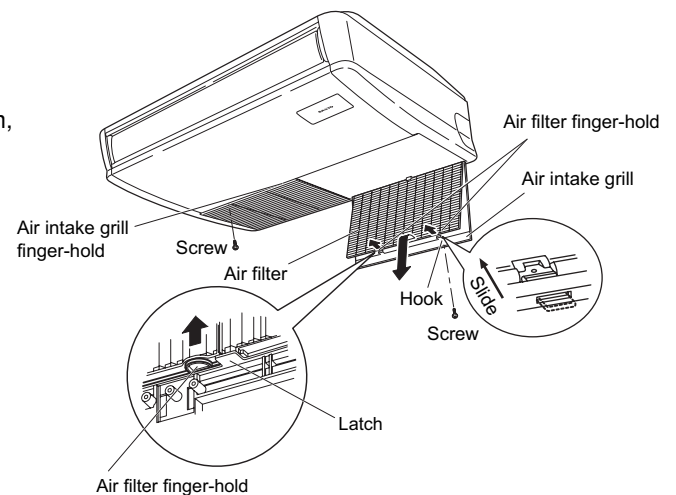

Air filter finger-hold

* Take hold of the finger-hold on the air filter, pull it toward you.

**CAUTION**

1. **Certain metal edges and the condenser fins are sharp and may cause injury if handled improperly; special care should be taken when you clean these parts.**
2. **Periodically check the outdoor unit to see if the air outlet or air intake is clogged with dirt or soot.**
3. **The internal coil and other components of the outdoor unit must also be cleaned periodically. Consult your dealer or service center.**

Care: After a prolonged idle period Check the indoor and outdoor unit air intakes and outlets for blockage; if there is a blockage, remove it.

- Care: Before a prolonged idle period**
- Operate the fan for half a day to dry out the inside.
 - Disconnect the power supply and also turn off the circuit breaker.
 - Clean the air filter and replace it in its original position.
 - Outdoor unit internal components must be checked and cleaned periodically. Contact your local dealer for this service.

■ TROUBLESHOOTING

If your air conditioner does not work properly, first check the following points before requesting service. If it still does not work properly, contact your dealer or a service center.

Trouble	Possible Cause	Remedy
Air conditioner does not run at all	<ol style="list-style-type: none"> 1. Power failure. 2. Leakage circuit breaker has tripped. 3. Line voltage is too low. 4. Operation button is turned off. 5. The wired remote control unit or heat pump is malfunctioning. (The inspection mark \triangle and the letters E, F, H, L, P in combination with numbers appear on the LCD of the wired remote control unit.) 	<ol style="list-style-type: none"> 1. After a power outage, press ON/OFF operation button on the wired remote control unit. 2. Contact service center. 3. Consult your electrician or dealer. 4. Press the button again. 5. Consult your dealer.
Compressor runs but soon stops	<ol style="list-style-type: none"> 1. Obstruction in front of condenser coil 	<ol style="list-style-type: none"> 1. Remove obstruction
Poor cooling (or heating) performance	<ol style="list-style-type: none"> 1. Dirty or clogged air filter. 2. Heat source or many people in room. 3. Doors and/or windows are open. 4. Obstacle near air intake or air discharge port. 5. Thermostat is set too high for cooling (or too low for heating). 6. (Defrosting system does not work.) 	<ol style="list-style-type: none"> 1. Clean air filter to improve the airflow. 2. Eliminate heat source if possible. 3. Shut them to keep the heat (or cold) out. 4. Remove it to ensure good airflow. 5. Set the temperature lower (or higher). 6. (Consult your dealer.)

■ Tips for Energy Saving

- Avoid**
- Do not block the air intake and outlet of the unit. If either is obstructed, the unit will not work well, and may be damaged.
 - Do not let direct sunlight into the room. Use sunshades, blinds or curtains. If the walls and ceiling of the room are warmed by the sun, it will take longer to cool the room.
- Do**
- Always try to keep the air filter clean. (Refer to “Care and Cleaning.”) A clogged filter will impair the performance of the unit.
 - To prevent conditioned air from escaping, keep windows, doors and any other openings closed.

NOTE**Should the power fail while the unit is running**

If the power supply for this unit is temporarily cut off, the unit will automatically resume operation once power is restored using the same settings before the power was interrupted.

9-5. Wall-Mounted Type (K Type)

■ NAME OF PARTS

K Type (Wall-Mounted)

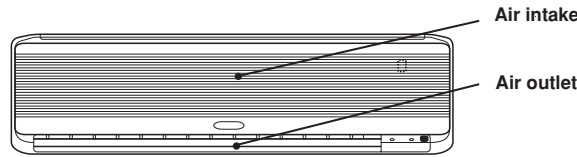

■ CARE AND CLEANING



WARNING

1. For safety, be sure to turn the air conditioner off and also to disconnect the power before cleaning.
2. Do not pour water on the indoor unit to clean it. This will damage the internal components and cause an electric shock hazard.

Air intake and outlet side (Indoor unit)

Clean the air intake and outlet side of the indoor unit with a vacuum cleaner brush, or wipe them with a clean, soft cloth.

If these parts are stained, use a clean cloth moistened with a mild liquid detergent. When cleaning the air outlet side, be careful not to force the vanes out of place.



CAUTION

1. Never use solvents or harsh chemicals when cleaning the indoor unit. Do not wipe plastic parts using very hot water.
2. Some metal edges and the fins are sharp and may cause injury if handled improperly; be especially careful when you clean these parts.
3. The internal coil and other components of the outdoor unit must be cleaned every year. Consult your dealer or service center.

Air filter

The air filter collects dust and other particles from the air and should be cleaned at regular intervals as indicated in the table below or when the filter indication () on the display of the remote control unit (wired type) shows that the filter needs cleaning. If the filter gets blocked, the efficiency of the air conditioner drops greatly.

Type	Period
K	2 weeks

NOTE

The frequency with which the filter should be cleaned depends on the environment in which the unit is used.

<How to clean the filter>

1. Remove the air filter from the air intake grille.
2. Use a vacuum cleaner to remove light dust. If there is sticky dust on the filter, wash the filter in lukewarm, soapy water, rinse it in clean water, and dry it.

<How to remove the filter>

1. Move the flap on the air outlet grille to its lowest position with the remote control unit.
2. The filter is disengaged by pushing the tab up gently. Hold the air filter by the tab at the bottom, and pull downward.

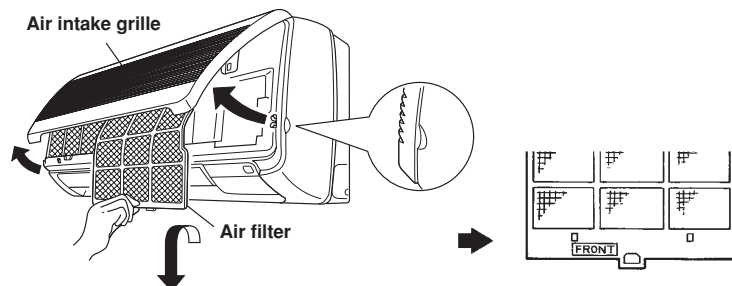

When replacing the filter, make sure that the FRONT mark is facing you. Push it up until you hear it click back into position.



CAUTION

1. **Certain metal edges and the condenser fins are sharp and may cause injury if handled improperly; special care should be taken when you clean these parts.**
2. **Periodically check the outdoor unit to see if the air outlet or air intake is clogged with dirt or soot.**
3. **The internal coil and other components of the outdoor unit must also be cleaned periodically. Consult your dealer or service center.**

Care: After a prolonged idle period Check the indoor and outdoor unit air intakes and outlets for blockage; if there is a blockage, remove it.

Care: Before a prolonged idle period

- Operate the fan for half a day to dry out the inside.
- Disconnect the power supply and also turn off the circuit breaker.
- Clean the air filter and replace it in its original position.
- Outdoor unit internal components must be checked and cleaned periodically. Contact your local dealer for this service.

■ TROUBLESHOOTING

If your air conditioner does not work properly, first check the following points before requesting service. If it still does not work properly, contact your dealer or a service center.

Trouble	Possible Cause	Remedy
Air conditioner does not run at all	<ol style="list-style-type: none"> 1. Power failure. 2. Leakage circuit breaker has tripped. 3. Line voltage is too low. 4. Operation button is turned off. 5. The wired remote control unit or heat pump is malfunctioning. (The inspection mark and the letters E, F, H, L, P in combination with numbers appear on the LCD of the wired remote control unit.) 	<ol style="list-style-type: none"> 1. After a power outage, press ON/OFF operation button on the wired remote control unit. 2. Contact service center. 3. Consult your electrician or dealer. 4. Press the button again. 5. Consult your dealer.
Compressor runs but soon stops	<ol style="list-style-type: none"> 1. Obstruction in front of condenser coil 	<ol style="list-style-type: none"> 1. Remove obstruction
Poor cooling (or heating) performance	<ol style="list-style-type: none"> 1. Dirty or clogged air filter. 2. Heat source or many people in room. 3. Doors and/or windows are open. 4. Obstacle near air intake or air discharge port. 5. Thermostat is set too high for cooling (or too low for heating). 6. (Defrosting system does not work.) 	<ol style="list-style-type: none"> 1. Clean air filter to improve the airflow. 2. Eliminate heat source if possible. 3. Shut them to keep the heat (or cold) out. 4. Remove it to ensure good airflow. 5. Set the temperature lower (or higher). 6. (Consult your dealer.)

■ Tips for Energy Saving

- Avoid**
- Do not block the air intake and outlet of the unit. If either is obstructed, the unit will not work well, and may be damaged.
 - Do not let direct sunlight into the room. Use sunshades, blinds or curtains. If the walls and ceiling of the room are warmed by the sun, it will take longer to cool the room.
- Do**
- Always try to keep the air filter clean. (Refer to “Care and Cleaning.”) A clogged filter will impair the performance of the unit.
 - To prevent conditioned air from escaping, keep windows, doors and any other openings closed.

NOTE

Should the power fail while the unit is running

If the power supply for this unit is temporarily cut off, the unit will automatically resume operation once power is restored using the same settings before the power was interrupted.

Free Manuals Download Website

<http://myh66.com>

<http://usermanuals.us>

<http://www.somanuals.com>

<http://www.4manuals.cc>

<http://www.manual-lib.com>

<http://www.404manual.com>

<http://www.luxmanual.com>

<http://aubethermostatmanual.com>

Golf course search by state

<http://golfingnear.com>

Email search by domain

<http://emailbydomain.com>

Auto manuals search

<http://auto.somanuals.com>

TV manuals search

<http://tv.somanuals.com>