



# SBC-116 Users Manual

## Multi-Function Caller ID Speakerphone

---



For problems with installation or operation, visit our web site at  
**[www.sbctelephones.com](http://www.sbctelephones.com)** or call **800-400-5156**

© 2006 Intellitouch, All rights Reserved SBC is a trademark of AT&T Knowledge Ventures, L.P. Licensed to Intellitouch

# FCC Registration Information

Your telephone equipment is registered with the Federal Communications Commission and is in compliance with parts 15 and 68, FCC Rules and Regulations.

## 1. Notification to the Local Telephone Company

On the bottom of this equipment is a label indicating, among other information, the FCC Registration number and Ringer Equivalence Number (REN) for the equipment. You must, upon request, provide this information to your telephone company. The REN is useful in determining the number of devices you may connect to your telephone line and still have all of these devices ring when your telephone number is called. In most (but not all) areas, the sum of the RENs of all devices connected to one line should not exceed 5. To be certain of the number of devices you may connect to your line as determined by the REN, you should contact your local telephone company.

### Notes

- This equipment may not be used on coin service provided by the telephone company.
- Party lines are subject to state tariffs, and therefore, you may not be able to use your own telephone equipment if you are on a party line. Check with your local telephone company.
- Notice must be given to the telephone company upon permanent disconnection of your telephone from your line.

## 2. Rights of the Telephone Company

Should your equipment cause trouble on your line which may harm the telephone network, the telephone company shall, where applicable, notify you that temporary discontinuance of service may be required. Where prior notice is not practicable and the circumstances warrant such action, the telephone company may temporarily discontinue service immediately. In case of such temporary discontinuance, the telephone company must: (1) promptly notify you of such temporary discontinuance; (2) afford you the opportunity to correct the situation; and (3) inform you of your right to bring a complaint to the Commission pursuant to procedures set forth in Subpart E of Part 68, FCC Rules and Regulations. The telephone company may make changes in its communications facilities, equipment, operations of procedures where such action is required in the operation of its business and in compliance with FCC Rules and Regulations. If these changes are expected to affect the use or performance of your telephone equipment, the telephone company must give you adequate notice, in writing, to allow you to maintain uninterrupted service.

## Interference Information

This device complies with Part 15 of the FCC Rules. Operation is subject to the following two conditions: (1) This device may not cause harmful interference; and (2) This device must accept any interference received, including interference that may cause undesired operation. This equipment has been tested and found to comply with the limits for a Class B digital device, pursuant to Part 15 of the FCC Rules. These limits are designed to provide reasonable protection against harmful interference in a residential installation. This equipment generates, uses, and can radiate radio frequency energy and, if not installed and used in accordance with the instructions, may cause harmful interference to radio communications. However, there is no guarantee that interference will not occur in a particular installation. If this equipment does cause harmful interference to radio or television reception, which can be determined by turning the equipment off and on, the user is encouraged to try to correct the interference by one or more of the following measures:

- Reorient or relocate the receiving antenna (that is, the antenna for radio or television that is "receiving" the interference).
- Reorient or relocate and increase the separation between the telecommunications equipment and receiving antenna.
- Connect the telecommunications equipment into an outlet on a circuit different from that to which the receiving antenna is connected.

If these measures do not eliminate the interference, please consult your dealer or an experienced radio/ television technician for additional suggestions.

## Hearing Aid Compatibility

This telephone system meets FCC standards for Hearing Aid Compatibility.

FCC Registration Information.....	Inside Cover
Feature List.....	2
Safety Instructions.....	3
Introduction.....	4
Wall Mounting Instructions.....	5
Location Controls.....	6
Function Buttons.....	7
Function Operations.....	10
Talking Caller ID (TCID).....	13
Caller ID on Call Waiting.....	14
Receiving Call Records.....	15
Reviewing Display Messages.....	15
Message Waiting	
Total & New Calls	
Private	
Repeat Calls	
End of List	
Out of Area	
Low Battery Indicator	
Caller ID System Operations.....	16
Troubleshooting.....	17
Warranty.....	18

## Feature List

Speakerphone  
Message waiting lamp\*  
Talking Caller ID\*  
Caller ID with Caller ID call waiting\*  
Adjustable angle base  
Data port  
Adjustable volume control (handset, headset, speaker)  
Adjustable ringer control  
FSK system for message waiting notification (VMI)  
CID type II for caller/call waiting Caller ID\*  
2 one-touch Memory Speed dial buttons  
99 number/name in Caller ID history\*  
15 number outgoing call in memory  
70 name/number phone book  
Backlit LCD with contrast control  
Real time clock with date & time (automatically syncs with Caller ID\*)  
New call indicator  
LCD contrast setting  
Area code setting  
Multiple language selection  
Low Battery indicator  
Last number redial  
Flash, Pause, Mute  
Programmable one-touch Voice Message retrieve button\*  
Tone/Pulse Dialing  
Hold  
Call Timer  
Headset Button  
Headset jack

\* *function requires subscription to telephone company service*

To reduce the risk of fire, electrical shock, and injury, please follow these basic safety precautions before you use this equipment.

1. Carefully read the instructions in this manual.
2. Follow all warnings and instructions marked on the unit.
3. When cleaning, unplug the telephone jack from the wall outlet. Use a damp cloth. Do not use liquid or aerosol cleaners.
4. Do not use this equipment near water e.g.: near a sink, bathtub, swimming pool or in a wet basement.
5. Install in a protected location. Ensure all lines and cords are away from foot traffic. Do not place objects on the line cord that may cause damage or abrasion.
6. Avoid spilling any liquid on the unit. This may cause internal shorting, fire or shock. The phone is not covered for damage from liquids under your warranty.
7. Never push objects of any kind into the telephone as they can touch dangerous voltage points or short out parts that could result in a risk of fire or electrical shock.
8. Take the phone to a qualified technician when it requires repair work or service. To reduce the risk of electrical shock, do not disassemble the telephone. Opening or removing covers can expose you to dangerous voltages or other risks. Incorrect reassembly can cause electrical shock during subsequent use.
9. Avoid using the telephone during an electrical storm. There can be a slight risk of electrical shock from lightning.
10. Do not use the telephone to report a gas leak, if in the vicinity of the leak.
11. Unplug this telephone from the wall outlet and refer servicing to qualified service personnel under the following conditions:
  - If liquid is spilled into the unit.
  - If the unit is exposed to rain or water.
  - If the unit does not operate normally by following the operating instructions.
  - If the unit is dropped or the casing is damaged.
  - If the unit exhibits a distinct change in performance.
12. Do not recharge the batteries or dispose them in fire.
13. To avoid pollution to the environment, be sure to dispose of batteries properly.

## Introduction

Congratulations on the purchase of your new telephone. It has been manufactured to very high quality standards for convenient and reliable service. This telephone can be used with "Call Identification (Caller ID) Service" and/or "Call Waiting Caller ID Service" that is provided by your local telephone company. There is a fee for these services by your local telephone company, and they may not be available in all areas. When used with these services, your telephone displays the telephone number or the telephone number and name of each caller before you answer the call allowing you to screen your calls. In addition to Caller ID services, if you subscribe to voice mail services from your local telephone company, voice mail waiting indicators will inform you that there is a message waiting in your voice mailbox.

### CHECK THE CONTENTS OF THE BOX

Box should contain:

- Handset with handset cord and phone base
- Telephone line cord
- Three AA size 1.5V batteries
- User's manual
- Power Adapter

### BATTERY INSTALLATION

The Caller ID phone requires three 1.5V R6P SUM-3 SIZE AA batteries for LCD display.

1. Remove the battery cover from the back of your Caller ID phone.
2. Insert three 1.5V AA size batteries by observing the +/- polarity marked in the battery compartment.
3. Replace battery compartment cover.

### CONNECTING PHONE LINE CORDS

Plug one end of the supplied telephone line cord into the line jack. Then plug the other end into telephone line jack. Plug in the AC power adapter into a power outlet and the plug the other end into 9VDC jack.

### BASIC CONNECTION DIAGRAM

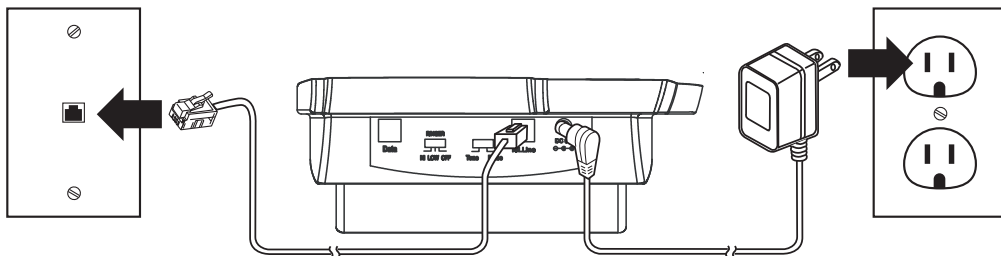

## Wall Mounting Instructions

The unit can be mounted to any wall surface using two self-tapping screws (not supplied). Follow the instructions.

1. Install two self-tapping screws at a distance of 10.5cm (4.125") from each other and located on a vertical center line. (See Figure 1)

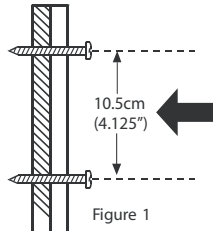

2. Tighten each screw just enough to allow the wall mounting bracket enough clearance to slip snugly over each screw head.
3. Pull out the mounting stand to the wall mounting position shown in Figure 5.

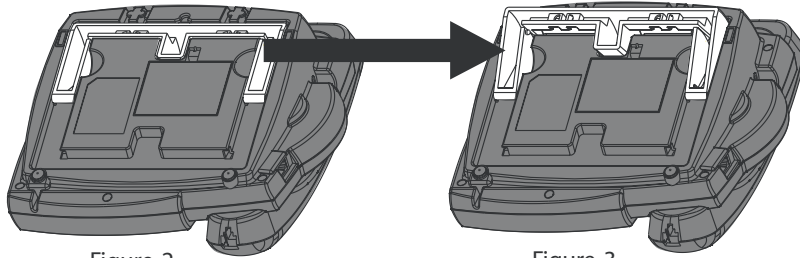

4. To install as a wall unit.
  - a. Align the holes on the back of the telephone mounting plate with the heads of the self tapping screws.
  - b. Slowly slide the unit down until it snaps into place as shown in figure 6.
5. For desktop use, the mounting stand can be left flush to the base or raised to a medium or high position as shown in figure 3 and 4.

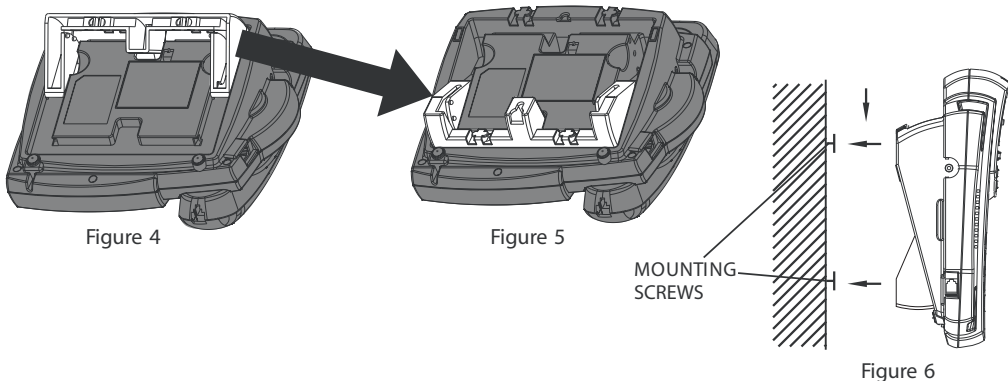

## Location Of Controls

1. Message Waiting lamp
2. **MENU** button
3. **DELETE** button
4. **ENTER** button
5. **SAVE** button
6. **MESSAGE** button
7. ▲ or ▼ button (Up and Down)
8. **M1** (memory 1) button
9. **M2** (memory 2) button
10. **FLASH** button
11. **REDIAL** button
12. **HEADSET** button
13. **MUTE** button
14. **HOLD** button
15. **SPEAKER** button
16. Volume (◀ and ▶) buttons
17. Data jack
18. Ringer volume switch
19. Dialing mode switch
20. Telephone line jack
21. 9VDC power jack
22. Headset jack
23. Handset jack

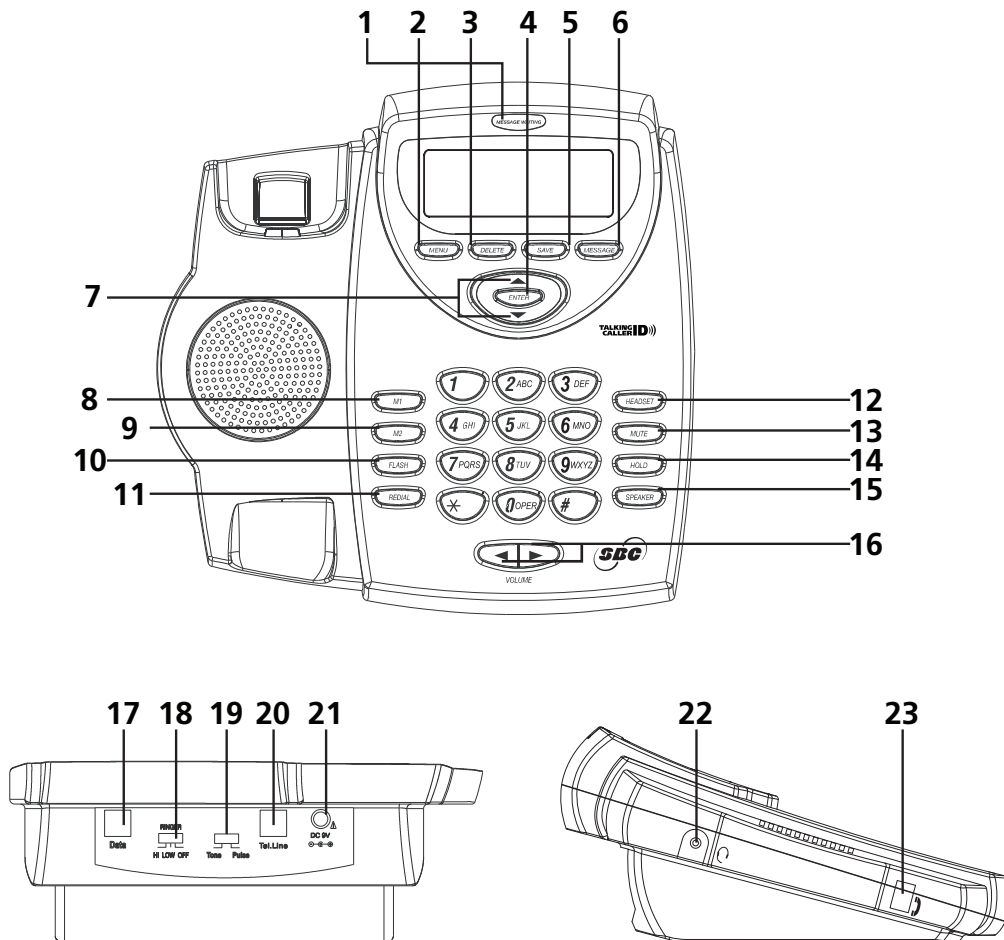



## **Message Waiting Lamp**

If you subscribe to "Voice Messaging" (a service offered by your telephone company) this lamp will flash whenever a new message is on the system. This light should stop flashing after the call is retrieved.

## **MENU Function**

Use this button to access a variety of the phones functions displayed on the LCD.

## **DELETE Function**

Use this button to delete an entry or to exit from a menu.

## **SAVE Function**

Use this button to save numbers to your phone book feature.

## **ENTER Function**

Use this key to enter new phone book records or to dial a number from the Caller ID or Dialed Call records.

## **MEMORY Dialing Function**

**M1, M2** buttons – Use these one-touch buttons to store frequently dialed phone numbers or Centrex system features.

To store a number in a memory button:

1. Enter number using the dialing keypad.
2. Press and hold the **M1** or **M2** button until "SAVE OK" appears on the LCD

## **HOLD Function**

To put a caller on hold, press the **HOLD** button. The LCD will display "Holding" indicating that the call is on hold. To continue the conversation, just press the **SPEAKER** button or pick up the handset.

*NOTE: In the HOLD mode, you can hang up the handset. To resume the conversation, just pick up the handset.*

## **REDIAL Function**

The phone supports 2 redial functions:

1. Last Number Redial – to redial the last dialed number, pickup the handset and press **REDIAL** button. The phone will automatically redial the last number dialed.
2. Memory Redial – the phone stores the last 15 dialed calls. To dial a call from memory, with handset on-hook, press the **REDIAL** button and use the **▲** and **▼** buttons to scroll through the dialed call records. When the number you want to redial is displayed, pick up handset and the number displayed on the LCD will be dialed.

## **SPEAKER Function**

Your phone features a speakerphone for ease of use and convenience during a phone conversation. Press the **SPEAKER** button to activate the speakerphone function. At any time during a conversation, you can lift the handset to stop using the speakerphone. Likewise, when you are using the handset, press the **SPEAKER** button and place the handset in the cradle to switch to speakerphone. You may adjust the volume of the speakerphone by using the **VOLUME** **◀** and **▶** buttons.

### **MUTE Function**

Pressing the **MUTE** button turns off the telephone's microphone so that the other party cannot hear you, but you can hear them. Pressing the **MUTE** button again restores connection to the microphone so the other party can again hear you. The LCD will display "MUTE" while the function is active.

### **FLASH Button**

If you subscribe to "Call Waiting" (a special telephone service) the **FLASH** button is used to connect the line to another incoming call or to establish a dial tone to make another call while still connected to the initial caller.

*Note: If you do not subscribe to Call Waiting, pressing the **FLASH** button during a call will disconnect the current call.*

### **Phone Book Function**

You can store 70 numbers and names in the phone book, refer to the "FUNCTION OPERATIONS", under the "PHONE BOOK" section for details.

### **HEADSET Function**

To use a headset, connect a headset with a 2.5mm connector into the headset jack. To make a call, press the **HEADSET** button. A dial tone will be heard on the headset and the phone may be dialed. To end the call, push the **HEADSET** button again.

### **Volume Function**

The volume level of the handset, headset and speakerphone can be set using the volume ◀ and ▶ buttons. To adjust, go off-hook with either the handset, headset or speakerphone. The LCD will display the volume setting information as it is adjusted.

### **Ringer Volume Switch**

Set the ringer volume switch to the desired position (HI/LOW/OFF). To have the maximum ringer volume, move the ringer volume switch to the HI position. To have a low ringer volume, move the ringer volume switch to the LOW position. If you would prefer the ringer not to disturb you, move the ringer volume switch to the OFF position.

### **Pulse/Tone Switch**

Set it to TONE if you have "touch tone dialing", or set it to PULSE if you have a "rotary dial phone".

### **▲ ▼ Buttons Function**

Use these buttons to scroll through menu functions, Caller ID, Dialed Calls and Phone book records.

**MESSAGE Button**

If you subscribe to "Voice Messaging" (a special telephone service), this function will operate in the following manner:

When the ☒ indicator is displayed on the LCD and the "Message Waiting" lamp is on, you can press the **MESSAGE** button to connect to your "Voice Messaging" service. When pressed, the phone will automatically dial \*98 (this is the default), which is the code to access "Voice Messaging" in many areas.

- **Re-Programming The MESSAGE Button**

Access codes for network services are not the same for all telephone companies. To store a different access number or to restore the access number to the appropriate button, do the following:

1. In the on-hook state enter your access number.
2. Press and hold the **MESSAGE** button until the LCD shows "SAVE OK".

## Function Operations

To access the function settings of this phone, press the **MENU** button and use the ▲ or ▼ buttons to select a function. *NOTE: The phone must be in the on-hook position to access the MENU mode settings.*

The setting sequence is PHONE BOOK - CALL WAITING - DATE FORMAT - HOUR FORMAT - SET FLASH - SET AREA CODE - SET LANGUAGE - SET TIME - LCD CONTRAST - BACK LIGHT - SET TALKING CID. After selecting the desired function, press the **ENTER** button to review or change settings. When complete, press the **MENU** button to exit.

### PHONE BOOK

#### ➔ To add number and name to the phone book:

1. Press the **MENU** button to select the PHONE BOOK menu then press **ENTER**; the LCD will show: "REVIEW >>". Press the ▲ or ▼ button to select the ADD >> menu, then press the **ENTER** button to enter the function for adding name and number to the PHONE BOOK.
2. Using the keypad, enter the phone number. To delete a number incorrectly entered, press the **DELETE** button to delete the incorrect digit(s) and reenter the correct digit(s). *NOTE: the maximum number of digits that can be entered is 20; if the number exceeds 20, the LCD will show "TOO LONG" and the exceeding digits will not be stored.*
3. After finishing the number setting, press and hold the **ENTER** button to enter the name setting (the cursor will move to the next line), then press the appropriate keys to get the following characters:

Key	Characters	Key	Characters
1	1 . , ? ! - " ' ( )	6	M N O m n o 6 Ö Ø Ñ
2	A B C a b c 2 Ä Å Æ	7	P Q R S p q r s 7
3	D E F d e f 3	8	T U V t u v 8 Ü
4	G H I g h i 4	9	W X Y Z w x y z 9
5	J K L j k l 5	0	0 + & @ / \$ %

If the next character is on the same button as the previous one, you press the **ENTER** button before entering the same letter again. *NOTE: To add a space between names press ENTER-TWICE.*

4. When the setting is completed, press and hold the **ENTER** button to store the record and go on to the next phone number you want to enter.

#### ➔ To review the number/name in phone book:

1. With the phone on-hook, press the **MENU** button to select the PHONE BOOK menu, then press **ENTER**, the LCD will show "REVIEW >>". Press the **ENTER** button to enter the function of reviewing the name/number. Use the ▲ or ▼ button to review. You can also quickly review the list by the first letter of the name. When pressing the first letter of the name, the LCD will display the matching name(s), then use the ▲ or ▼ button to select the right one.

2. With the phone on-hook, you may directly access the phone book by pressing the number **1** plus #. The LCD will show the first name/number entry in the phone book. Use the **▲** or **▼** button to scroll to the desired name/number. The contact displayed in the LCD can be automatically dialed by picking up the handset.

*NOTE: If the number is more than 13 digits, an arrow will show on the bottom right of LCD, press **▲** or **▼** button to review the other digits, press the **▲** or **▼** button again to review the next number.*

➔ **To speed dial the number from the phone book:**

**Off Hook** - With the phone in the off-hook state, press **MENU** then use the **▲** or **▼** button to select the name/number you want. When the LCD displays the contact you want to call, press the **ENTER** button.

**On-Hook** - Press the number **1** plus #, use the **▲** or **▼** button to select the contact you want to call. When the name/number is displayed, pick up the handset and the phone will automatically dial the number.

➔ **To delete a single entry in the phone book:**

During the reviewing process, use the **▲** or **▼** button to select the number you want to delete, press the **DELETE** button once, the LCD shows "DELETE?" Press the **DELETE** button again to delete it.

### CALL WAITING SETTING

Press the **MENU** button, using the **▲** or **▼** scroll to CALL WAITING - press **ENTER** and the current status will display. Press the **▲** or **▼** button to make a selection (ON/OFF). Press the **ENTER** button to confirm and the **MENU** button to exit.

### DATE FORMAT SETTING

Press the **MENU** button, using the **▲** or **▼** scroll to DATE FORMAT - press **ENTER** and the current date format will display. Press the **▲** or **▼** button to make a selection (DD/MM or MM/DD). Press the **ENTER** button to confirm and then press the **MENU** button to exit.

*Note:*

1. In the DD-MM mode, the time sequence is day-month;
2. In the MM-DD mode, the time sequence is month-day.

### HOURLY FORMAT SETTING

Press the **MENU** button, using the **▲** or **▼** scroll to HOUR FORMAT - press **ENTER** and the current time format will be displayed. Press the **▲** or **▼** button to make a selection (24 HOUR / 12 HOUR). Press the **ENTER** button to confirm and then press the **MENU** button to exit. *Note - If you subscribe to the Caller ID service, the Caller ID will automatically set time and date.*

### FLASH TIME SETTING

Press the **MENU** button, using the **▲** or **▼** scroll to SET FLASH - press **ENTER** button and the current flash time will show on the LCD. Use the **▲** or **▼** button to change the flash time (100ms/120ms/300ms/600ms). Press the **ENTER** button to confirm and then press the **MENU** button to exit.

## Function Operations

### AREA CODE SETTING

When you use this phone for the first time, or move to an area that has a different area code, you must enter your area code. This is necessary because the phone must distinguish local or long distance calls to properly dial calls from the Caller ID list and phone book.

1. Press the **MENU** button, using the ▲ or ▼ scroll to SET AREA CODE - press **ENTER** button.
2. LCD will Display "SET AREA CODE".
3. Using the keypad dial buttons, enter your area code. Press \* to move the cursor or press # to delete.
4. When the three-digit area code setting has been completed (for example: if your area code is 858 the display will show '858') then press **ENTER**
5. Phone will return to main menu

### LANGUAGE SELECTION

The phone supports multiple languages. Press the **MENU** button, using the ▲ or ▼ scroll to SET LANGUAGE - press **ENTER** to enter the language setting, then press the ▲ or ▼ button to select the language. Press the **ENTER** button to confirm and exit.

### TIME SETTING

If you have subscribed to Caller ID, the date and time will be automatically set when the first call is received. To set the time manually follow the instructions below:

Press the **MENU** button, using the ▲ or ▼ scroll to SET TIME - press **ENTER**, then using the keypad, enter the correct time, date and day of week. Press the **MENU** button to exit.

The setting sequence is hours - minutes - month - date - year - day of week.

After the year setting, the cursor for day of week will flash, you can use the ▲ or ▼ button to activate/deactivate this setting. If the flashing cursor is active, the day of week will set automatically, or if deactivated, the LCD will only show the "TOTAL CALLS XX" in the standby state.

### LCD CONTRAST SETTING

The phone features an LCD contrast control which can be adjusted for optimum viewing depending on phone angle and lighting. To change, press the **MENU** button, using the ▲ or ▼ scroll to LCD CONTRAST - press **ENTER**. The LCD shows "SET CONTRAST XX".

Press the ▲ or ▼ button to select the LCD contrast (up to 16 levels for choosing), press the **ENTER** button to confirm.

### BACK LIGHT/OFF HOOK LIGHT SETTING

Press the **MENU** button, using the ▲ or ▼ scroll to BACK LIGHT - press **ENTER**. Press the ▲ or ▼ button to select either BACK LIGHT TIME or OFF HOOK LIGHT.

**To adjust BACK LIGHT time:** The phone features a backlight LCD that is illuminated whenever you touch a key or remove the handset. When the LCD shows "BACK LIGHT TIME". Press **ENTER** and then the ▲ or ▼ button to select the time you would like the BACK LIGHT to remain illuminated, or select BACK LIGHT OFF if you do not want the LCD to illuminate. Press the **ENTER** button to confirm.

**To adjust OFF HOOK light time:** While in the BACK LIGHT mode press ▲ or ▼ and the LCD will display "OFF HOOK LIGHT" - When the LCD shows "OFF HOOK LIGHT". Press the **ENTER** then ▲ or ▼ button to select if you would like the BACK LIGHT to remain illuminated ALL THE TIME or FOR SECONDS (time chosen for the BACK LIGHT time). After selecting, press **ENTER** to confirm, then press **MENU** to exit.

### Talking Caller ID (TCID)

This feature allows you to know who is calling without looking at the display. When a call comes in, the phone will announce the caller's name displayed on the LCD after the second ring. To use this feature, you must subscribe to your telephone company's Caller ID service. If a call is received from an area or system where name display service is not available, "Number available" will be announced.

Please note:

- TCID announcement is heard after the second ring and between every ring thereafter.
- Caller ID supports names of up to 15 letters. If the caller's name has more than 15 letters, the name will not be displayed or announced correctly.
- If you subscribe to a distinctive ring service (such as IDENT-A-RING), your unit may mute one or more of the rings in order to announce the name of the caller.
- When you receive a call while on the phone, the 2nd caller's name will not be announced.

#### TALKING CID SETTING

Talking Caller ID is ON by default. To turn off Talking Caller ID, press **MENU** then press the ▲ or ▼ button to select SET TALKING CID and press **ENTER**. Choose VOICE TALKING and press **ENTER**. Then press the ▲ or ▼ button and choose OFF. Press the **ENTER** button to confirm and the **MENU** button to exit.

#### CALL FROM

When a call is received, the phone will announce "Call from..." before the CID. This feature is ON by default. To turn off the "Call from..." announcement, press **MENU** then press the ▲ or ▼ button to select SET TALKING CID and press **ENTER**. Choose CALL FROM and press **ENTER**. Then press the ▲ or ▼ button and choose OFF. Press the **ENTER** button to confirm and the **MENU** button to exit.

#### TALK VOLUME

To turn adjust the volume of the TCID announcement, press **MENU** then press the ▲ or ▼ button to select SET TALKING CID and press **ENTER**. Choose TALK VOLUME and press **ENTER**. Then press the ▲ or ▼ button to set the TCID volume level between four levels. Press the **ENTER** button to confirm and the **MENU** button to exit.

*Note: You can also adjust the TCID volume by pressing the ◀ ▶ buttons while the phone is in standby mode.*

## Talking Caller ID (TCID)

### PERSONALIZING TCID ANNOUNCEMENTS

You can personalize the way that a call is announced by simply entering a name and number in the Phone Book on the phone. The name stored in the Phone Book will override the name attached to the Caller ID record. For instance, if the name passed through with a Caller ID record is Smith Julie (or, for that matter, "Unknown Name", by adding this phone number to the phone book and entering a new name, the call can be announced as "The Smiths" or "Julie" (or whatever you choose to enter as a name associated with that Caller ID number.)

*Note: Caller ID on the LCD display is either the name provided by the phone company's CID or the name in your phone's phone book. The Talking Caller ID announcement is either the name provided by the phone company's CID or the phone's phone book.*

## Caller ID Call Waiting

When you subscribe to Caller ID/Call Waiting service from your local telephone company, the telephone will display the name and number of the second caller while you are having a conversation.

### Caller ID info displayed

Caller 1  
555-1234

### Caller two's information is displayed

Caller 1  
5  
Caller 2  
555-5678

1. When you are on the line, the telephone will display the name and number of the second caller.
2. Press the **FLASH** button to answer the second caller.
3. When you have finished, press the **FLASH** button to continue with your conversation with the first caller.



A caller ID record consists of the following information:

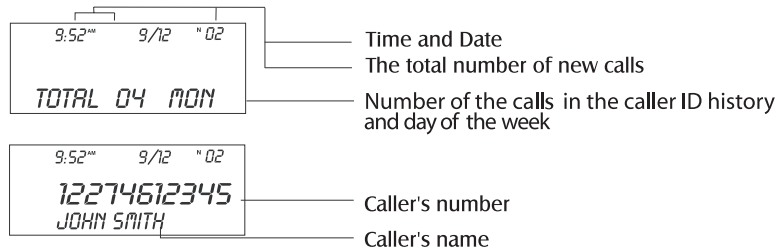

## Reviewing Display Messages

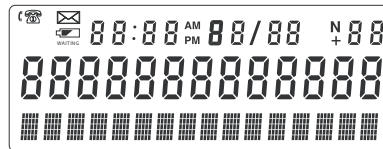

**MESSAGE WAITING** - If you have voice mail service from your telephone company and a message is left, the MESSAGE WAITING light will turn on and the message icon will appear in the upper left corner of the LCD. The MESSAGE WAITING light and message icon will remain illuminated until you have retrieved your voice mail and the MESSAGE WAITING will be saved as a call.

*NOTE: This function should be supported by your telephone company.*

**TOTAL & NEW CALLS** - This shows you the total and new calls to be reviewed. In this example, you have a total of 4 calls which include 2 new calls and it is MONDAY.

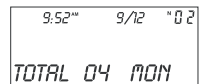

**PRIVATE CALLER** - If the caller has exercised the option to prevent his name and number from being sent, "PRIVATE CALLER" will show on the screen.

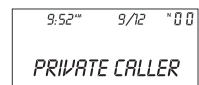

**REPEAT CALLS** - If a call comes repeatedly, the display will show the phone number of the caller plus the repeat icon (+) in the upper right corner of the LCD.

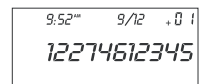

**END OF LIST** - This LCD displays "END OF LIST" when reaching the top (end) of the call history list. If there is no call, then LCD shows "NO CALL".

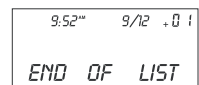

**OUT OF AREA** - This message will display when someone calls from an area where the telephone company is not offering the caller identification services or is not yet providing number delivery to your area.

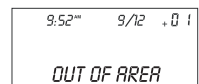

**BATTERY LOW INDICATOR** - If there is low battery, the battery low icon  will turn on and flash.

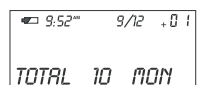

## Caller ID System Operations

Subscription to Caller ID service and/or voice mail service from your local phone company is required to experience these features.

- **New Voice Message Indicator** - The red indicator light above the LCD will flash to indicate that you have a new voice message waiting. The lamp will continue to flash until all the new calls have been reviewed.
- **Review Your Call Records** - Use the ▲ or ▼ button to scroll through the caller list. If the call is more than 13 digits, the arrow will show on the bottom right of LCD, press the ▲ or ▼ button once to review the other digits, press the ▲ or ▼ button again to review next call. At the end of the call record list, you will see the "END OF LIST" message. Press the ▲ or ▼ button to continue.
- **Save Call Records** - Your phone automatically stores up to 99 call records. Once the memory is full, the phone will automatically delete the oldest call record from the list. You can free up memory space by manually deleting calls from this record.
- **Delete Single or All Record Number(s)** - In the on-hook state, use the ▲ or ▼ button to select the number which you want to remove, press the **DELETE** button, the LCD will show "DELETE?" and then press the **DELETE** button again to remove this number, press any button to exit. If you press the **DELETE** button for about 6 seconds, the LCD will show "ALL DELETE?" and press the **DELETE** button to remove all numbers and the LCD will show "NO CALL".
- **Using The Call Back Feature**

*(NOTE: If the number is blocked or is not available, it can not be call backed.)*

**Call back an outgoing number:** The unit stores your most recent 15 dialed numbers.

1. In the on-hook state, press the **ENTER** button once, the last dialed number will show on the LCD, then use the ▲ or ▼ button to select the number that you want to dial out.
2. Pick up the handset, the phone number will be dialed out automatically.

**Call back an incoming number:** The unit stores a minimum of 99 incoming numbers.

1. In the on-hook state, use the ▲ or ▼ button to select the call you want to call return.
2. Pick up the handset, the phone number will be dialed out automatically.

If you have problems with your phone, please check below for helpful hints:

### **BLANK OR FAINT LCD**

- Check and adjust the LCD Contrast. Check the line cord. Connect the telephone cord. Check batteries, Check adapter power adapter connection to phone and wall.

### **PHONE WILL NOT RING**

- Check ringer switch on the back of the phone. If ringer is on, you may have too many communication devices hooked to a single line. A communication device can be a phone, modem or facsimile (FAX) machine. Contact your telephone company for help in calculating the limit for your residence or business line.

### **NO DIAL TONE**

- Verify that the line cord is plugged in correctly.
- Verify that the line cord connection is correct and tightly secured.

### **CALLER ID WILL NOT WORK PROPERLY/NO CALL DATA RECEIVED**

Caller ID data can take up to two rings to appear on the screen. If data does not appear, or does not appear correctly check the following:

- Call your telephone company to verify that your caller ID services are active.
- If you have an answering machine connected to this Phone, ensure that your answering machine is set to answer after at least two rings.
- Do not answer the call before two rings.
- Contact your telephone company if the problem continues for more than 24 hours. The telephone company may be experiencing temporary line problems.

### **NO RESPONSE ON LCD DISPLAY**

- If you have experienced a power failure or the AC adapter has not been connected to the phone for a period of time, the batteries for memory back up could become weak or dead. If the display screen does not respond after the power is restored and/or the AC adapter is reconnected, replace the batteries with new ones.

## Warranty

This product has a one-year over the counter warranty. For any inquiries after the warranty period, please contact IntelliTouch at (800) 400-5156. Hours are from 8:00 a.m. to 5:00 p.m. PST, Monday through Friday or visit [www.sbctelephones.com](http://www.sbctelephones.com).



In case of difficulties, visit our service center at  
**[www.sbctelephones.com](http://www.sbctelephones.com)** or call **800-400-5156**

© 2006 Intellitouch

All rights Reserved

SBC is a trademark of AT&T Knowledge Ventures, L.P,

Licensed to Intellitouch

Printed in China

Download from [Www.Somanuals.com](http://Www.Somanuals.com). All Manuals Search And Download.

## Free Manuals Download Website

<http://myh66.com>

<http://usermanuals.us>

<http://www.somanuals.com>

<http://www.4manuals.cc>

<http://www.manual-lib.com>

<http://www.404manual.com>

<http://www.luxmanual.com>

<http://aubethermostatmanual.com>

Golf course search by state

<http://golfingnear.com>

Email search by domain

<http://emailbydomain.com>

Auto manuals search

<http://auto.somanuals.com>

TV manuals search

<http://tv.somanuals.com>