

LCD PROJECTOR LENS

MODEL LNS-W32

LENS REPLACEMENT PROCEDURE

NOTE; Lens installation is different in cabinet design and lens attachment method (Type A, B and C). Before installation the lens, check cabinet design and proper installation should be made.

NOTES ON LENS REPLACEMENT

The ZOOM, FOCUS and LENS SHIFT adjustment on the Top Control or the Remote Control cannot be operated with this Lens.

Lens replacement should be performed by the qualified service personnel.

It should be followed by this procedure precisely.

Before attempt to replace the lens, confirm the model number (both the LCD projector and the lens) and use the proper lens.

The lens cover is on the lens for protection. Be sure to remove the lens cover before installation.

When installing or removing the lens, be careful not to stain, scratch or damage the lens.

PARTS LIST

Following parts are contained in the packing.

● LENS	1 piece
● LIGHT-BLOCK SHEET BASE	1 piece (Part No. 610 310 8001)
● DRIVER (3 mm, Green)	1 piece (Part No. 610 287 7328)
● DRIVER (4 mm, Yellow)	1 piece (Part No. 610 275 6029)
● LIGHT-BLOCK SHEET	1 piece Type PC1 (Part No. 610 310 7967) 1 piece Type PD1 (Part No. 610 294 3047)
● SCREW	2 pieces (Spare parts)

Following checks and confirmations should be taken for safety.

Check the following things by the time of the cabinet assembly after the lens replacement.

1. Check the lens is securely fixed.
2. Check no parts is missing, or no mounting part is loose.

Some parts are not used for installation or replacement. Keep these parts and drivers included in the lens for later use.

LENS REPLACEMENT PROCEDURE (FOR "A" TYPE)

NOTE; When installation of this lens to the "A" type, needs an additional Front Panel. Contact to our sales dealer for ordering.

Perform the steps **1** to **5** for lens replacement.

First set the lens at the center position with lens shift adjustment.

1 REMOVE THE LENS COVER AND LIGHT-BLOCK SHEET (See Figure-1 and 2)

1. Remove 2 screws-A.
2. Press the button (or remove 2 screws-B) on the lower of the front panel and remove the front panel.
3. Remove the light-block sheet from the light-block sheet base.

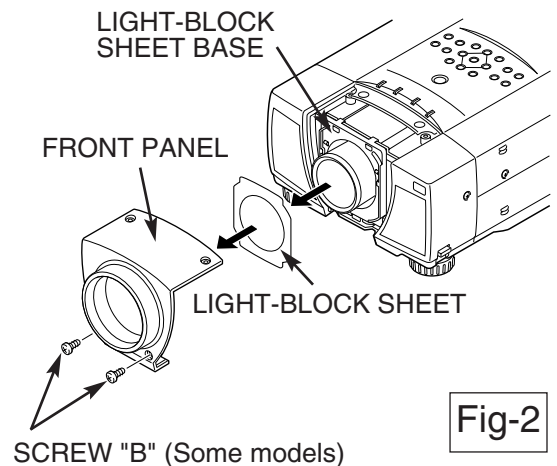
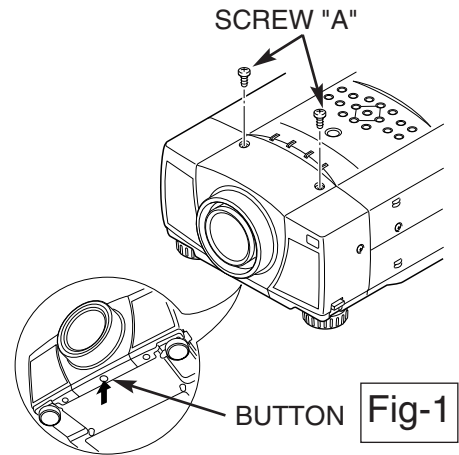

2 REMOVE THE LIGHT-BLOCK SHEET BASE (See Figure-3 and 4)

1. Slide the light-block sheet base upward.
2. Remove the light-block sheet base.

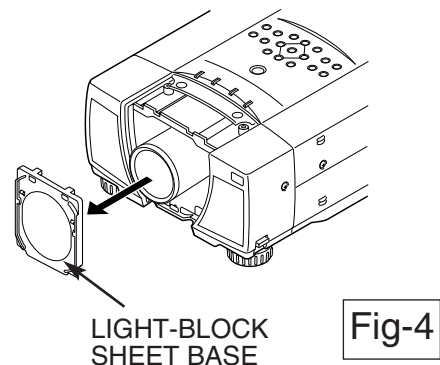
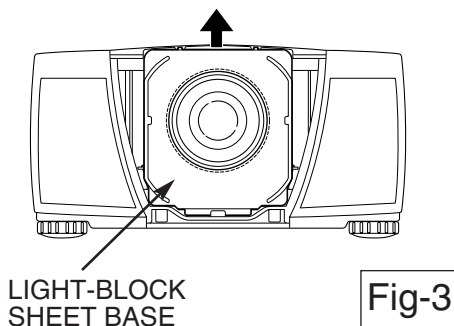

3 REMOVE THE LENS (See Figure-5 and 6)

1. Disconnect the Lens Shift connector "K16L" from the circuit board on cabinet left side.
2. Disconnect the Zoom and Focus connector "K16J" from the circuit board.

Remove the lens motor lead from lead holder.

3. Remove screws-C (4 screws) which fastens the lens and remove the lens. Use the driver (3 mm, Green) included with the lens to remove the screws.

Be careful not to drop the lens when removing the screws.

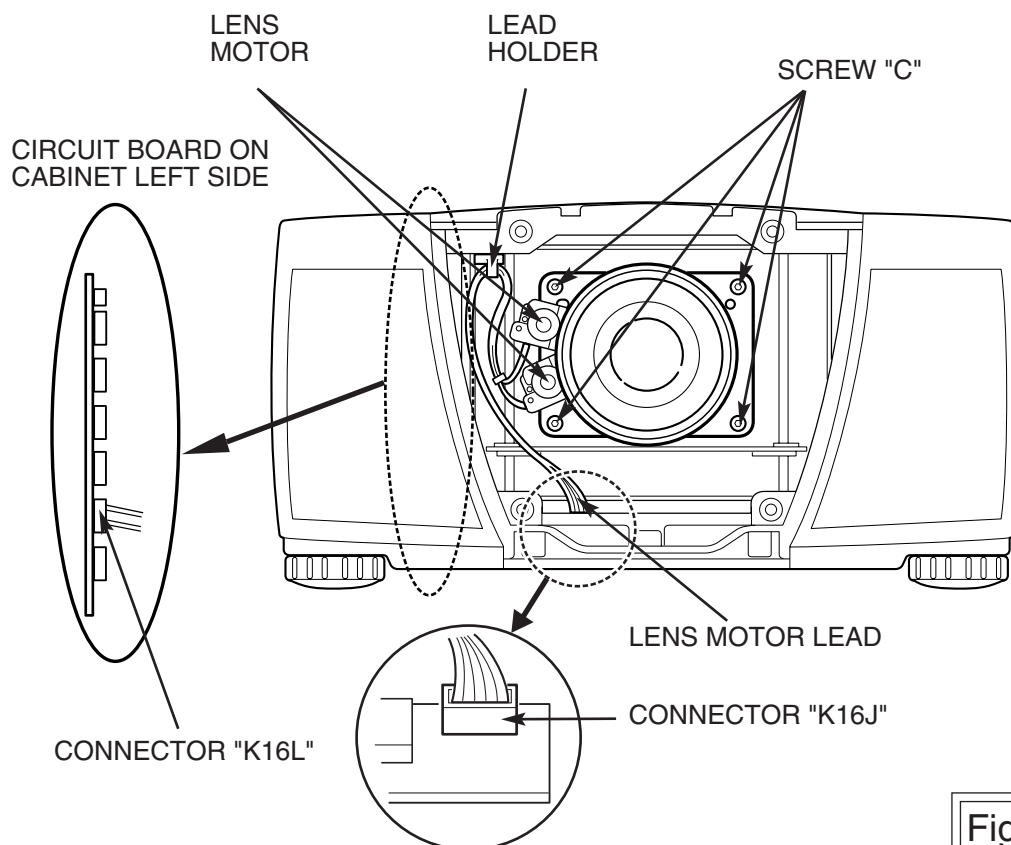

Fig-5

4 MOUNT THE LENS (See Figure-5 and 6)

1. Remove protective caps (front and back) on the lens.
2. Mount the lens on lens mounting bracket with 4 screws.

Use the driver (4 mm, Yellow) included with the lens to fasten the screws.

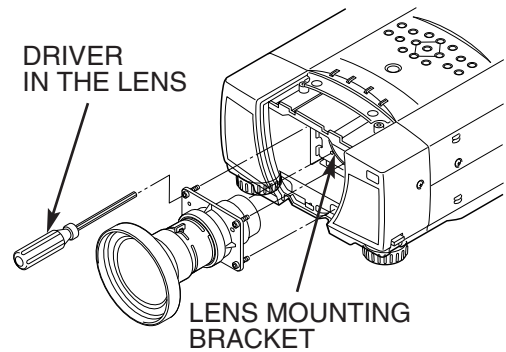

Fig-6

CONFIRM THE FOCUS

Project picture on screen and confirm the focus. If proper focus is not observed at screen, adjust focus following Focus Adjustment on this page.

5 MOUNT THE LIGHT-BLOCK SHEET AND FRONT PANEL (See Figure-7)

1. Mount the light-block sheet to the lens as shown in the Figure-7. Use the sheet included with the lens.
2. Make sure the part no. and mark (TOP and BACK) on Light-Block Sheet and set them properly.
3. Mount the Front Panel (Separately ordered) with the screws.

Light block sheet base is not used.

LIGHT-BLOCK SHEET
Type PD1
(Part No. 610 294 3047)

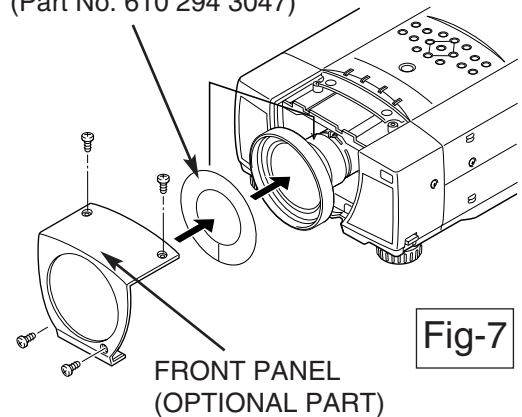

Fig-7

FOCUS ADJUSTMENT

Set up the projector and project image on the screen.

1. Loosen the Focus Lock Screw on the lens.
2. Rotate the lens to obtain proper focus on center area of the screen.
3. Tighten the Focus Lock Screw.

When proper focus is not observed at outer area of the screen, proceed to following adjustments.

4. Loosen the Focus Lock Ring of the lens. (Turn the Lock Ring to counter-clockwise.)
5. Rotate the lens to obtain proper focus on outer area of the screen.
6. Lock the Focus Lock Ring securely. (Turn the Lock Ring to clockwise.)

If proper focus is not observed entire screen, repeat above adjustment 1~ 6.

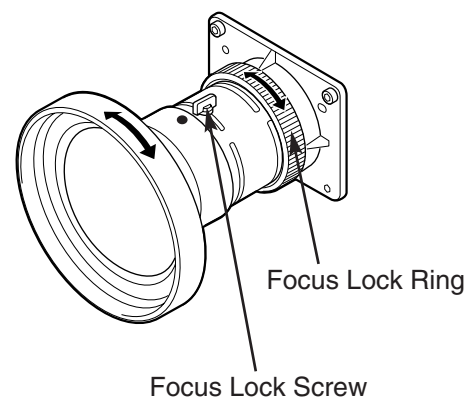

LENS REPLACEMENT PROCEDURE (FOR "B" TYPE)

Perform the steps **1** to **5** for lens replacement.

First set the lens at the fully lower position with lens shift adjustment.

1 REMOVE THE LENS COVER AND FRONT CABINET

1. Turn the lens cover to counter-clockwise and pull it toward front and remove the Lens Cover.
2. Remove 2 Screws-A.
3. Remove the front cabinet

See Figure-1-1 and 2.

1. Remove 3 Screws-A.
2. Remove the front cabinet

See Figure-1-2 and 2.

1. Pull Lens Cover toward front and remove it.
2. Remove 2 Screws-A.
3. Remove the front cabinet

See Figure-1-3 and 2.

2 REMOVE THE LIGHT-BLOCK SHEET BASE AND LIGHT-BLOCK SHEET (See Figure-2)

1. Slide the light-block sheet base upward and remove it.
2. Remove the light-block sheet from lens.

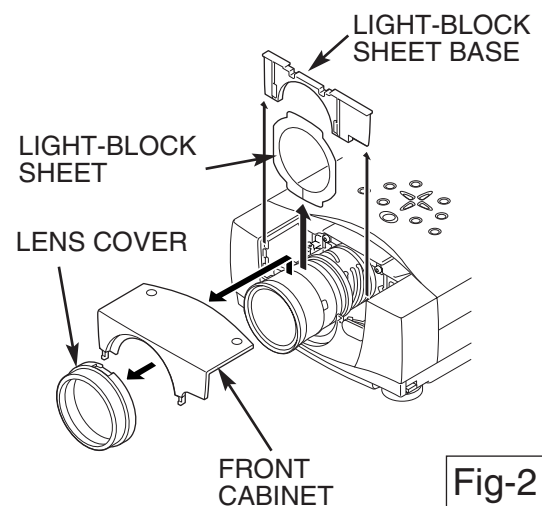
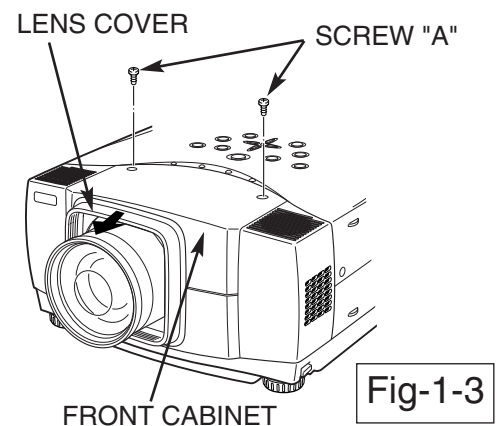
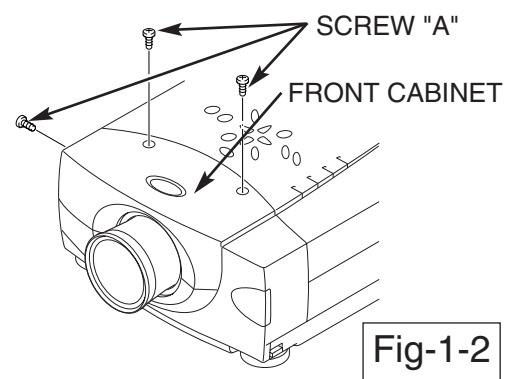
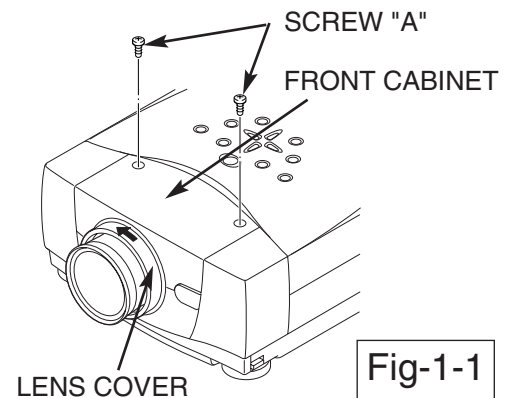

3 REMOVE THE LENS (See Figure-3 and 4)

1. Remove the lens motor connector from terminal.
2. Loosen the screws-B (2 screws) which fastens the lens. {Use the driver (4 mm, Yellow) included with the lens to loosen the screws.}
3. Slide the lens lock latches to "UNLOCK" position and remove the lens.

Be careful not to drop the lens when removing the screws. After using, save the driver for latter use.

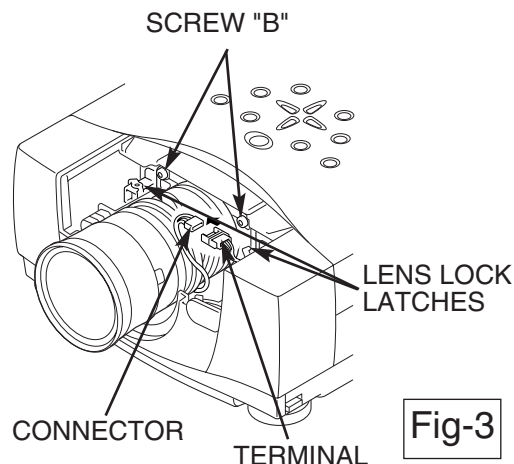

Fig-3

LENS LOCK LATCHES

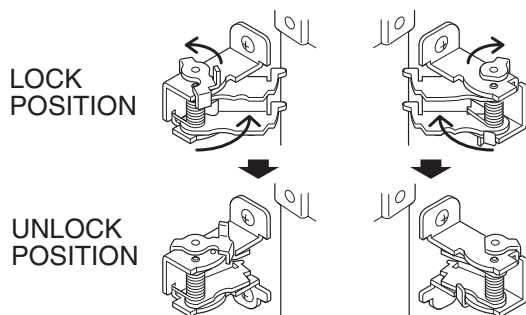

Fig-4

4 MOUNT THE LENS (See Figure-5)

1. Remove protective caps (front and back) on the lens.
2. Mount the lens on lens mounting bracket with Upper 2 screws.
Use the driver (4 mm, Yellow) included with the lens to fasten the screws.
Remove the lower 2 screws on the Lens. (Lower 2 screws are not used.)
3. Slide the lens lock latches to "LOCK" position and lock the lens. (See Figure-4)

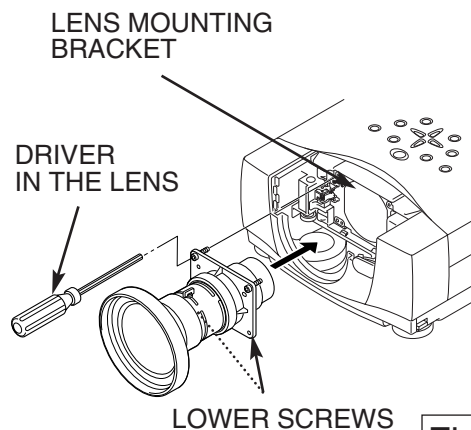

Fig-5

CONFIRM THE FOCUS

Project picture on screen and confirm the focus. If proper focus is not observed at screen, adjust focus following Focus Adjustment on next page.

5 MOUNT THE LIGHT-BLOCK SHEET AND LIGHT-BLOCK SHEET BASE (See Figure-6)

1. Mount the light-block sheet on the lens. (In the same position as the removed sheet has been placed). Use the sheet included with the lens.
Make sure the mark (TOP and BACK) on Light-Block Sheet and set them properly.
2. Mount the light-block sheet base included with the lens.

LIGHT-BLOCK SHEET

Type PC1
(Part No. 610 310 7967)

LIGHT-BLOCK SHEET BASE

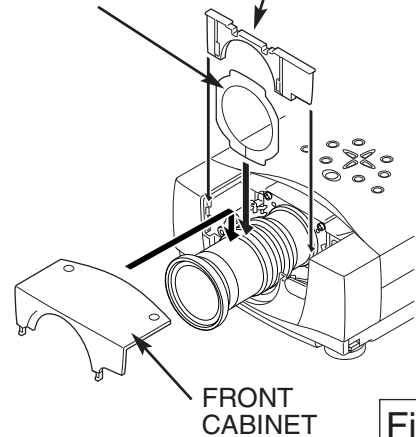

Fig-6

6 MOUNT THE FRONT CABINET AND LENS COVER (See Figure-7)

1. Mount the front cabinet with 2 screws.

Lens cover is not used.

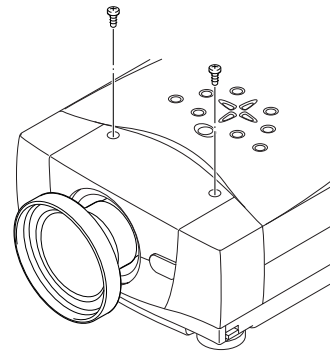

Fig-7

FOCUS ADJUSTMENT

Set up the projector and project image on the screen.

1. Loosen the Focus Lock Screw on the lens.
2. Rotate the lens to obtain proper focus on center area of the screen.
3. Tighten the Focus Lock Screw.

When proper focus is not observed at outer area of the screen, proceed to following adjustments.

4. Loosen the Focus Lock Ring of the lens. (Turn the Lock Ring to counter-clockwise.)
5. Rotate the lens to obtain proper focus on outer area of the screen.
6. Lock the Focus Lock Ring securely. (Turn the Lock Ring to clockwise.)

If proper focus is not observed entire screen, repeat above adjustment 1~ 6.

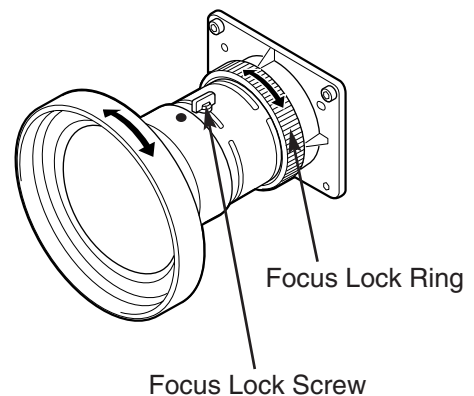

LENS REPLACEMENT PROCEDURE (FOR "C" TYPE)

Perform the steps **1** to **6** for lens replacement.

First set the lens at the fully lower position with lens shift adjustment.

1 REMOVE THE LENS COVER AND FRONT CABINET

1. Turn the lens cover to counter-clockwise and pull it toward front and remove the Lens Cover.
2. Remove 2 Screws-A.
3. Remove the front cabinet

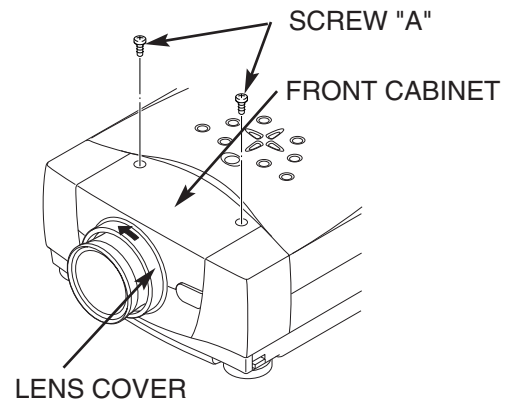

2 REMOVE THE LIGHT-BLOCK SHEET BASE AND LIGHT-BLOCK SHEET

1. Slide the light-block sheet base upward and remove it.
2. Remove the light-block sheet from lens.

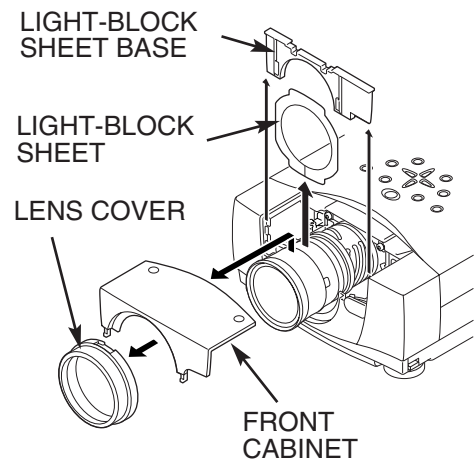

3 REMOVE THE LENS

1. Grasp the Lens Lock Lever and turn it fully upward. Remove the Lens into the projector.
2. Disconnect the lens motor lead connector to the socket on the lens attachment.
3. Remove 4 Screws and remove lens attachment.

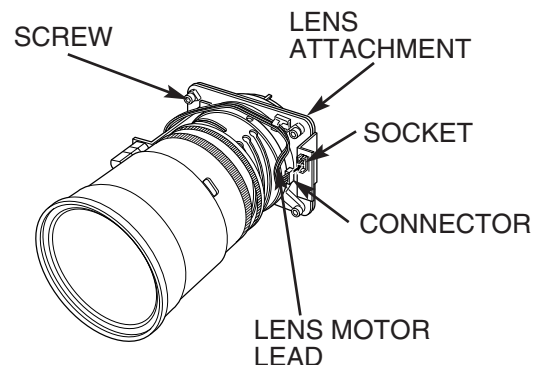
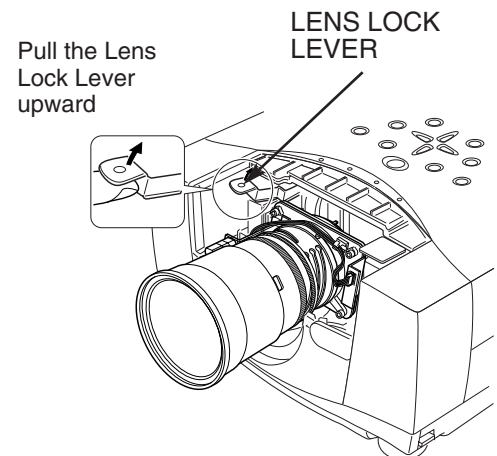

4 MOUNT THE LENS

1. Remove protective caps (front and back) on the optional lens.
2. Mount the lens on the lens attachment with 4 Screws.
3. Connect the lens motor lead connector to the socket on the lens attachment.
4. Grasp the Lens Lock Lever and turn it fully upward. Install the Lens into the projector. Turn the Lens Lock Lever fully downward until lever is Locked (clicked position) properly. After installing the lens, make sure the Lens is not loose and properly installed.

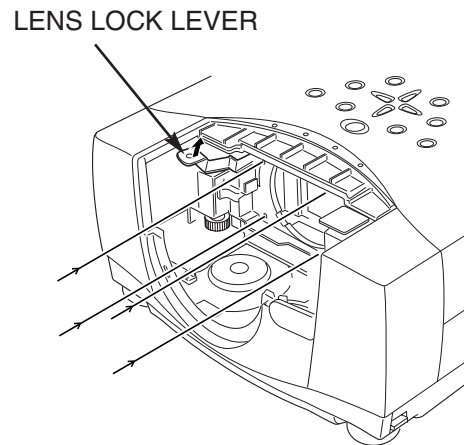
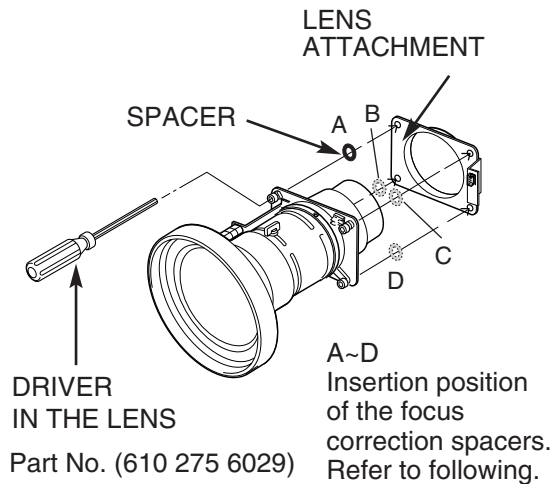

Push the Lens Lock Lever fully downward until it is locked (clicked).

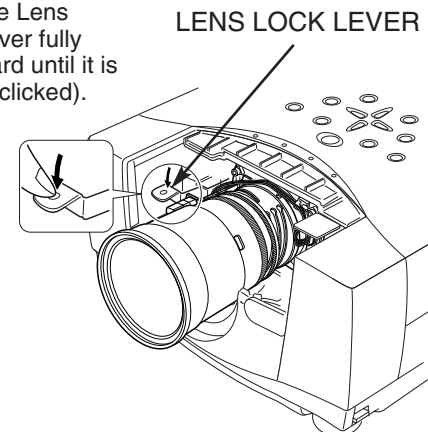





Correcting the focus

When the lens is attached to the projector and images are being projected onto the screen, the peripheral focus may be out of focus in some localized areas. If this happens, insert the spacer in between the lens attachment and the lens to correct the focus.

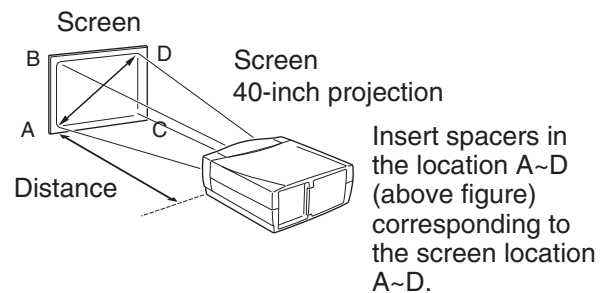
Inserting the spacers corrects the distance for best diagonal focus at the screen.

The corrected distance is determined by the thickness of the spacers that are used. As a guide, the distance is adjusted by approximately 30 mm for each 0.1-mm thickness of the spacers. There are three types of spacers provided, and there are four of each spacer type. Use these spacers to correct the distance as required.



	Spacer "1" Color; Clear Thickness; 0.1 mm	Correction distance 30 mm/for 40-inch projection
	Spacer "2" Color; Black Thickness; 0.2 mm	Correction distance 55 mm/for 40-inch projection
	Spacer "1" Color; Cream Thickness; 0.3 mm	Correction distance 80 mm/for 40-inch projection

5 MOUNT THE LIGHT-BLOCK SHEET AND LIGHT-BLOCK SHEET BASE

1. Mount the light-block sheet on the lens. (In the same position as the removed sheet has been placed). Use the sheet included with the lens.
Make sure the mark (TOP and BACK) on Light-Block Sheet and set them properly.
2. Mount the light-block sheet base included with the lens.

LIGHT-BLOCK SHEET

Type PC1
(Part No. 610 310 7967)

LIGHT-BLOCK SHEET BASE

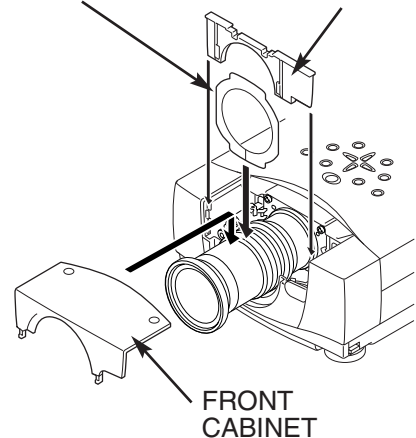

6 MOUNT THE FRONT CABINET AND LENS COVER

1. Mount the front cabinet with 2 screws.

Lens cover is not used.

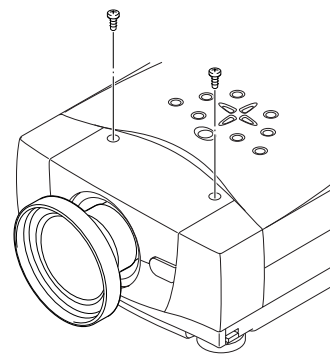

FOCUS ADJUSTMENT

Set up the projector and project image on the screen.

1. Loosen the Focus Lock Screw on the lens.
2. Rotate the lens to obtain proper focus on center area of the screen.
3. Tighten the Focus Lock Screw.

When proper focus is not observed at outer area of the screen, proceed to following adjustments.

4. Loosen the Focus Lock Ring of the lens. (Turn the Lock Ring to counter-clockwise.)
5. Rotate the lens to obtain proper focus on outer area of the screen.
6. Lock the Focus Lock Ring securely. (Turn the Lock Ring to clockwise.)

If proper focus is not observed entire screen, repeat above adjustment 1~ 6.

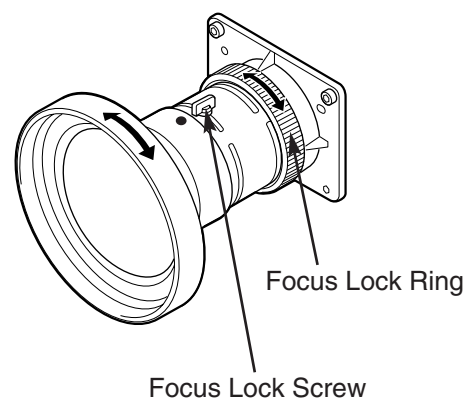

Free Manuals Download Website

<http://myh66.com>

<http://usermanuals.us>

<http://www.somanuals.com>

<http://www.4manuals.cc>

<http://www.manual-lib.com>

<http://www.404manual.com>

<http://www.luxmanual.com>

<http://aubethermostatmanual.com>

Golf course search by state

<http://golfingnear.com>

Email search by domain

<http://emailbydomain.com>

Auto manuals search

<http://auto.somanuals.com>

TV manuals search

<http://tv.somanuals.com>