



INSTRUCTION MANUAL

使用説明書

사용 설명서

取扱説明書

MICRO-COMPUTERIZED PRESSURE RICE COOKER

微電腦 壓力電飯鍋

마이컴 제어 압력 보온 밥솥

マイコン 圧力ジャー炊飯器

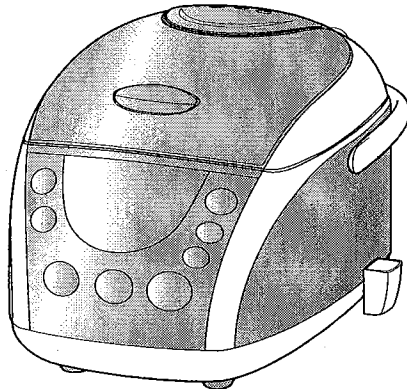

ECJ-PX50S

(5 Cups)

Thank you for your purchase of a Sanyo Pressure Rice Cooker. Please read these instructions carefully before use and save the manual for future reference.

Table of Contents	Page
Important Safeguards.....	2
Precautions.....	3-4
Names and Function of Parts.....	5
Controls/Display.....	6
Setting the Clock.....	7
Preparation for Cooking Rice.....	8
Cooking Rice.....	9-10
Tips for Cooking Rice.....	11
Timer Cooking.....	12-13
Important Things to Know.....	13
Keep Warm/Sleep.....	14
Steaming.....	15
Slow Cook/Specifications.....	16
Cleaning and Maintenance.....	17-18
Troubleshooting.....	19
Recipes.....	20-23
Warranty.....	24

HOUSEHOLD USE ONLY

IMPORTANT SAFEGUARDS

When using electrical appliances, follow basic safety precautions to reduce the risk of fire, electrical shock, and/or injury:

1. Read all instructions.
2. Do not touch HOT surfaces. Use handles or knobs.
3. To protect against fire, electrical shock, and personal injury, do not immerse cord, plugs or appliance in water or other liquid.
4. Close supervision is necessary when the appliance is used by or near children.
5. Unplug unit from outlet when not in use and before cleaning. Allow to cool before attaching or removing parts, and before cleaning the appliance.
6. Do not operate any appliance with a damaged cord or plug after the appliance malfunctions or has been damaged in any manner. Return appliance to an authorized service facility for examination, repair or adjustment.
7. To protect against risk of electrical shock, do not force any foreign objects, such as pins and wires, into any openings.
8. The use of accessory attachments not recommended by the appliance manufacturer may result in fire, electric shock or personal injury.
9. Do not use outdoors.
10. Do not let cord hang over edge of table or counter, or touch hot surfaces.
11. Do not place the appliance on or near a hot gas or electric burner, or in a heated oven.
12. Extreme caution must be used when moving an appliance containing hot oil or other liquids.
13. Do not clean the appliance with cleansers, steel wool pads, or other abrasive material.
14. Always press the **STOP/CANCEL** button, then remove power plug from electrical outlet.
15. Do not use appliance for other than intended use. This product is designed for household use only.
16. This appliance cooks under pressure. Improper use may result in scalding injury. Make sure unit is properly closed before operating.
17. Always check the pressure release devices for clogging before use. Please refer to pages 19-20.
18. Do not cook foods such as applesauce, cranberries, pearl barley, oatmeal or other cereals, split peas, noodles, macaroni, rhubarb or spaghetti. These foods tend to foam, froth or splatter and may block the pressure release device.
19. Do not open the pressure rice cooker until the unit has cooled and the internal pressure has been reduced.
20. Do not use this pressure cooker for pressure frying with oil.

SAVE THESE INSTRUCTIONS

Note:

- A. A short power cord is provided to reduce risks of becoming entangled in or tripping over a longer cord.
 - B. Extension cords are available and may be used if care is exercised in their use.
 - C. If extension cord is used:
 - (1) The marked electrical rating of the extension cord should be at least as great as the electrical rating of the appliance.
 - (2) The longer cord should be arranged so that it will not drape over the countertop or tabletop where it can be pulled on by children or tripped over.
- The appliance has a polarized plug (one blade is wider than the other is). As a safety feature, this plug will fit in a polarized outlet only one way. If the plug does not fit fully in the outlet, reverse the plug. If it still does not fit, contact a qualified electrician. Do not attempt to override this safety feature.











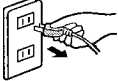



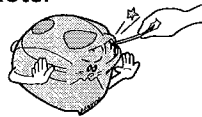

WARNING:

- Handling the cord on this product or cords associated with accessories sold with this product, will expose you to lead, a chemical known to the State of California to cause cancer, and birth defects or other reproductive harm. **Wash hands after handling.**
- **CALIFORNIA USA ONLY**
This rice cooker uses a Lithium Battery that contains Perchlorate Material-special handling may apply. See www.dtsc.ca.gov/hazardouswaste/perchlorate.

PRECAUTIONS

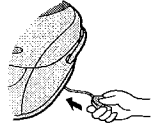
The important precautions described within this section must be followed carefully to prevent the possibility of personal injuries and/or property damage.

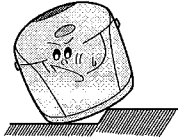
⚠ WARNING

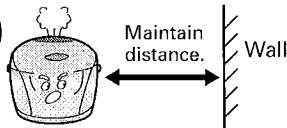
<ul style="list-style-type: none"> • Use only 120 Volt AC electrical current. 	<ul style="list-style-type: none"> • Do not attempt to plug in or unplug with wet hands.
<ul style="list-style-type: none"> • Always keep the power plug clean. If the power plug blades or plug surfaces become dirty, be sure that they are cleaned thoroughly. 	<ul style="list-style-type: none"> • Grasp only the power plug when unplugging the power cord.  
<ul style="list-style-type: none"> • Plug the appliance into a single electrical outlet only. Use only an electrical outlet rated at 15 amperes or more. Make sure that the power plug is firmly inserted into the electrical outlet. 	<ul style="list-style-type: none"> • Do not attempt to modify the appliance. All repairs must be performed by qualified technicians.
<ul style="list-style-type: none"> • Do not operate the appliance if the power cord or plug has been damaged. 	<ul style="list-style-type: none"> • Do not handle the power cord in a rough manner.
<ul style="list-style-type: none"> • Do not touch the steam vent. Do not place your face or hand near the steam vent.  	<ul style="list-style-type: none"> • Do not immerse the appliance in water and do not pour water onto it. This action may cause a short circuit or electric shock.  
<ul style="list-style-type: none"> • Do not allow children to use this appliance without adult supervision.  	<ul style="list-style-type: none"> • Do not insert any foreign objects into appliance openings or outlets.  
<ul style="list-style-type: none"> • Allow the appliance to cool off prior to cleaning. 	<ul style="list-style-type: none"> • Unplug the power plug from the outlet when the appliance is not being used.
<ul style="list-style-type: none"> • Do not touch the metal part on the inside of the lid or inner lid during or immediately after operation. This action may cause burn injuries.  	<ul style="list-style-type: none"> • Hold the power plug when retracting the power cord. If the power plug is not held, the uncontrolled moving cord may cause injury.  
<ul style="list-style-type: none"> • Do not operate the appliance near flames or wet areas. This action may cause electric shock or sparking. 	<ul style="list-style-type: none"> • Do not use any inner pot other than provided. Doing so may cause overheating and lead to a malfunction.
<ul style="list-style-type: none"> • Do not operate the appliance on an unstable surface or on any surface that is not resistant to heat. This operation may cause fire.  	<ul style="list-style-type: none"> • Do not place the appliance near walls or furniture (within 12"/30cm). Doing so may cause damage, possibly resulting in discoloration or disfiguration of the wall or furniture.  

PRECAUTIONS

BEFORE USE

Do not place the appliance in the following locations:

- Locations where hot cooking oil may splash onto the appliance.
- Locations where the appliance is exposed to direct sunlight.
- Locations without proper ventilation.

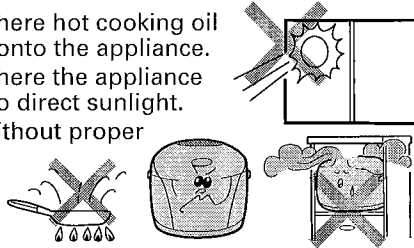

Do not use appliance if safety valve, pressure adjustment ball, or other inner lid areas are clogged.

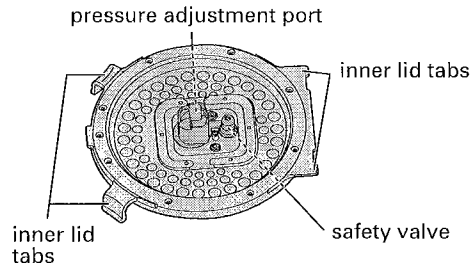

- If clogs are present, clean these areas before use.
- Do not operate appliance if upper or lower inner lid tabs are broken. Please refer to page 18.

Remove all foreign substances.

- Make sure that all rice grains and water drops on the appliance's inner wall, the outside of the inner pot, the heating element and the temperature sensor have been completely removed, before using appliance.

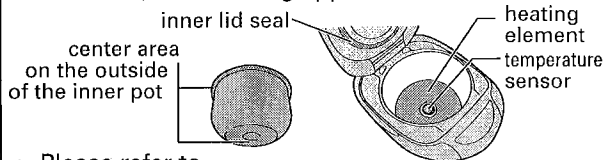

- Please refer to page 18 for care and maintenance for inner pot.

Do not use this appliance for cooking with oils, baking soda or flour.

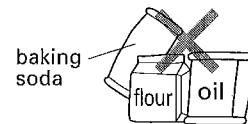

Do not add ingredients to inner pot above the MAX line.

- Overfilling may result in an overflow.



The gap between the outer lid and main unit is not a defect.

- This gap allows for pressure changes during use.

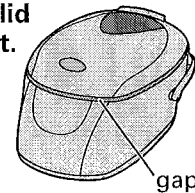

DURING USE

Avoid personal contact with steam vent.

- Escaping steam is HOT and may cause burns.
- Do not allow children near the steam vent.
- The appliance will feel hot-to-the-touch during and immediately following use. Use caution near appliance.

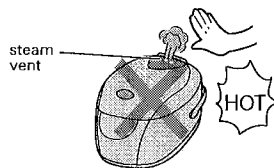

Do not open the outer lid during pressure cooking.

- The rice may not cook properly.
- If you must open the lid while cooking, please refer to page 13.

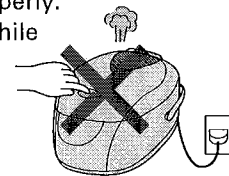

Do not carry the appliance by the handle.

- While rice is cooking, keep the handle folded down behind the appliance and do not carry it. Doing so may cause scalding burns or handle deformation due to escaping steam.
- If carrying the appliance immediately after use, use caution to avoid steam that is released from the steam vent.

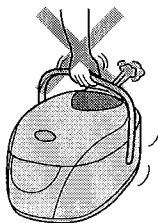

Do not operate appliance without any ingredients in inner pot.

- This will interfere with the micro-computerized program and may cause overheating.

Do not place a cloth or towels over the appliance during operation.

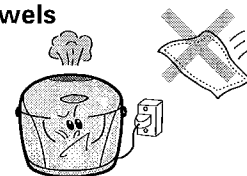

If appliance is damaged, stop using immediately and contact Sanyo Fisher Service.
Please refer to warranty, page 24.

NAMES AND FUNCTION OF PARTS

Steam Vent
(On top of the outer lid)

- Make sure that the steam vent has been firmly installed:
Do not touch the steam vent during or immediately after operation, as it becomes extremely hot.

Steam Vent Steam Holes

Lid Release

Press this button to open the outer lid. During pressure cooking, the outer lid will not open, even if this button is pressed. The lid seals closed once the pressure increases.

Inner Lid

For information about attaching and detaching the inner lid, please refer to page 6.

Precautions

Please read warnings and precautions thoroughly.

Pressure Adjustment Port
(Pressure Adjustment Ball)

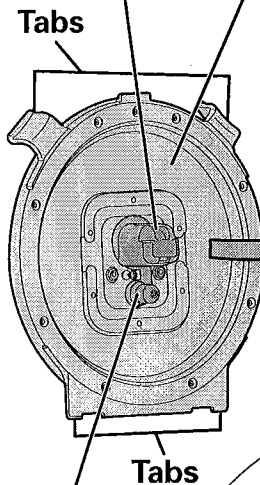

Outer Lid Handle

Safety Valve
Inner Pot

Main Unit

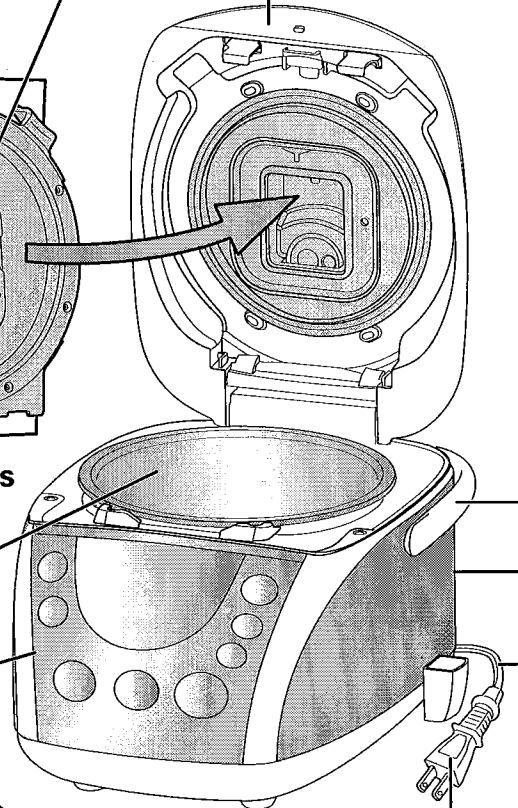

Accessories

Spatula

Measuring Cup (approximately 180ml)

Steamer Plate

Spatula Holder (Can be attached to either side of main unit)

To Attach: Insert the spatula holder into receptacle and push down.

To Detach: Grasp the spatula holder and pull upwards.

Receptacle

Power Plug

Power Cord

- **To pull out the power cord:** Hold the power plug and pull out the power cord. Do not pull power cord out beyond red mark.
- **To retract the power cord:** Pull power cord gently and release. It will retract automatically.

CONTROLS/DISPLAY

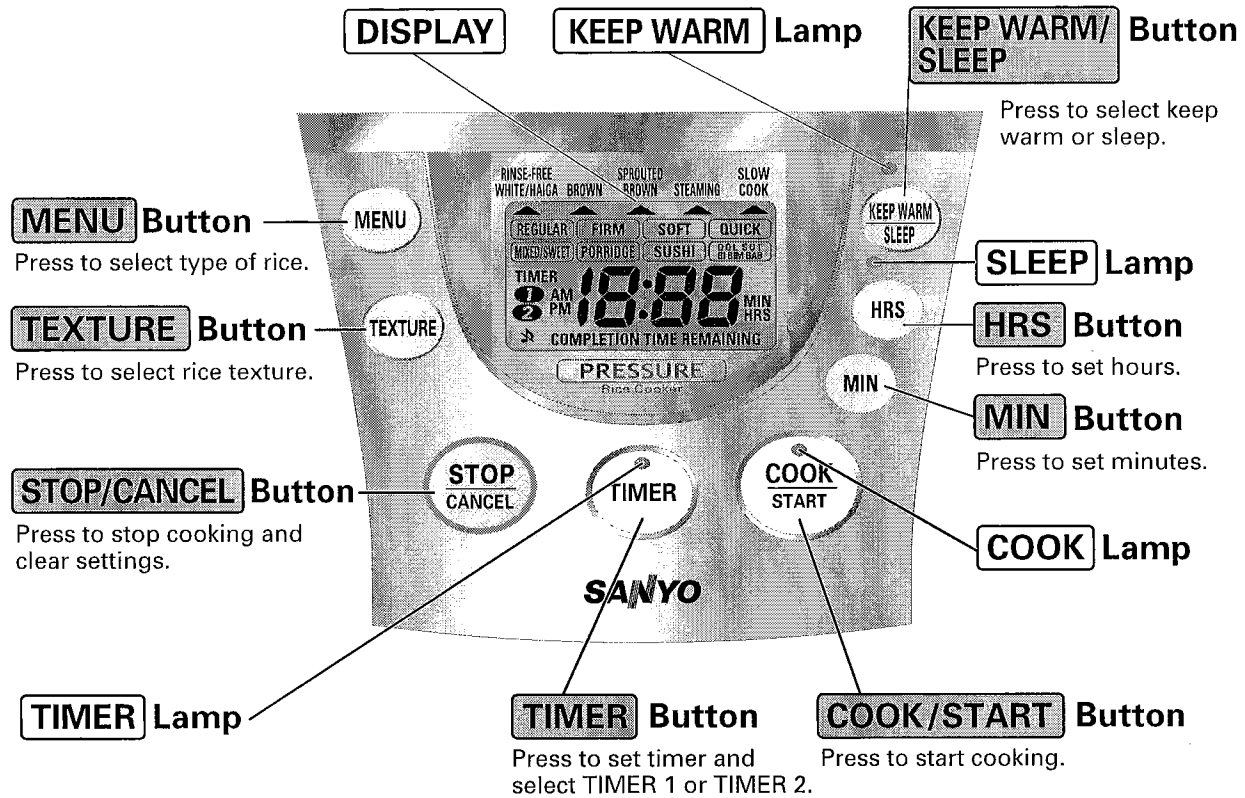

How to Attach and Detach the Inner Lid

To Detach:

Grasp one of the inner lid tabs with one hand. Pull the inner lid tab toward yourself, while at the same time pushing the locking flange upward with the other hand.

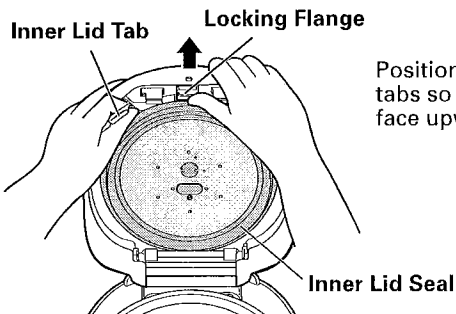

* Do not pull on the inner lid seal.

To Attach:

- ① Insert the protruding tabs into the spaces present in the lower part of the outer lid.
 - Make sure that the two protruding tabs are inserted into both of the appropriate spaces present in the outer lid.
- ② Push in the upper part of the inner lid until a "click" is heard.
 - Make sure that the inner lid is supported by the locking flange.

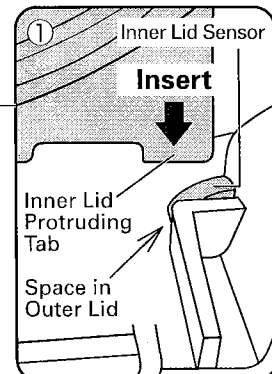
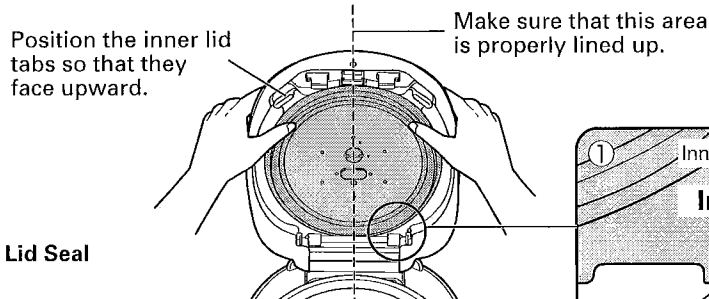

Caution!!

* Prior to rice cooking or keeping warm, make sure that the inner lid has been attached. The inner lid sensor detects the presence of the inner lid. If the inner lid is detached, the **COOK/START** button and the **KEEP WARM** button will not work. (This does not indicate a malfunction.) Make sure that all rice and foreign matter have been removed from around the inner lid sensor.

SETTING THE CLOCK

To set the correct time, follow the steps below.

EXAMPLE: When the current time is 8:00am, but the display shows 7:55am.

1 Insert the power plug into electrical outlet.

- The rice cooker uses a 12-hour clock.
12:00 midnight will be displayed as ^{AM} 0:00 and
12:00 noon will be displayed as ^{PM} 0:00.

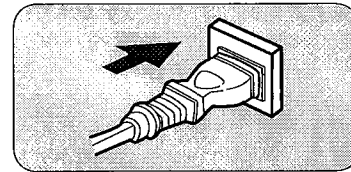

2 Press the **HRS** or **MIN** button until the time display begins to flash.

- The time display will begin flashing.

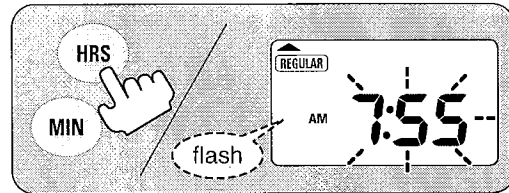

3 Press the **HRS** and **MIN** buttons to set the correct time.

- Press **HRS** to set "8". Press **MIN** to set "00".
- Holding down the buttons will allow the display to fast forward.
- The time display will stop flashing after 6 seconds.

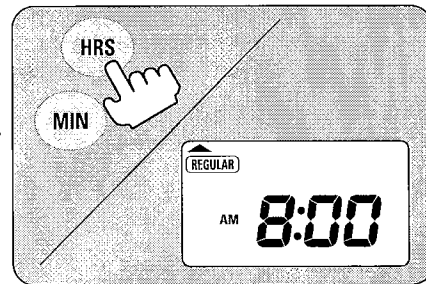

THE BUILT-IN LITHIUM BATTERY

- The appliance's internal lithium battery provides power to retain the time display and the timer setting, even when the power plug has been disconnected.
- The battery life expectancy is 4-5 years at a room temperature of 68°F/20°C. The battery may last longer when the appliance is plugged into the wall outlet because the battery power is not consumed.

SETTING THE INDICATOR BEEPS

Beeps will sound as an indicator that cooking is finished. Follow the steps below to turn this feature off. Beeps can be turned off ONLY during timer cooking.

- Insert the power plug into electrical outlet.

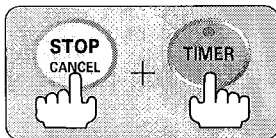

Press and hold the 2 buttons at the same time for 3 seconds or more.

- Press and hold the **STOP/CANCEL** button and **TIMER** button for more than 3 seconds.
- The display shows "⌘" and the indicator beeps are set OFF.

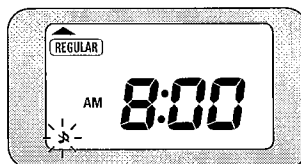

The indicator beeps are OFF.

- Press and hold the **STOP/CANCEL** button and **TIMER** button for more than 3 seconds.
- The display doesn't show "⌘" and the indicator beeps are set ON.

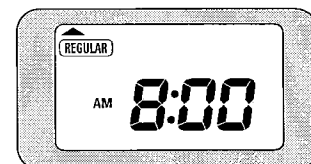

The indicator beeps are ON.

PREPARATION FOR COOKING RICE

1 Make sure that both the inner lid and the steam vent have been properly attached.

- When the **COOK/START** button is pressed and the inner lid is not attached, indicator beeps will sound.
- If the steam vent is not attached, it may cause the appliance to boil over while cooking.

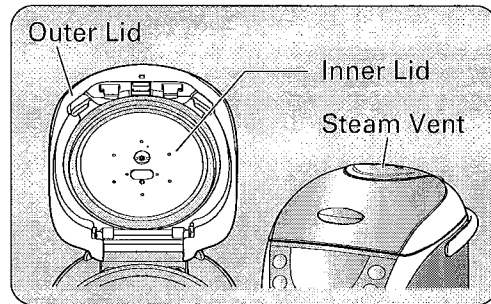

2 Measure the rice correctly. Wash the rice.

- Measure the rice using the measuring cup provided.
- The inner pot can be used to wash rice.
- Rinse quickly using a lot of water. Drain quickly.
- Gently rinse rice 2-3 times, until water becomes clear.

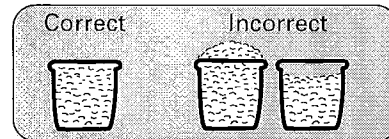

3 Add the appropriate level of water according to the menu setting selected and quantity of rice.

- The rice should be level.

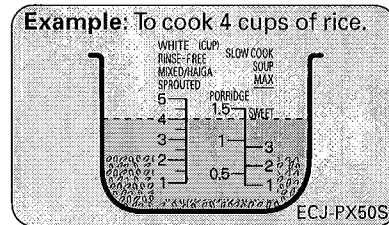

4 Place the inner pot into the main unit.

- Remove any water droplets or rice grains on the outside of the inner pot or on the inside of the main unit.
- Gently turn the inner pot from side to side so that it sits evenly on the heating element.

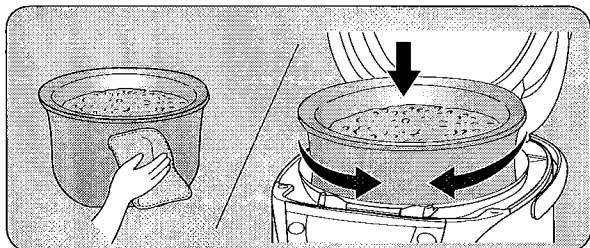

5 Close the outer lid. Insert the power plug into electrical outlet.

- Close the outer lid slowly and firmly by pushing down until you hear a click.
- You may feel slight resistance when closing the outer lid. This pressure rice cooker uses an air tight seal.

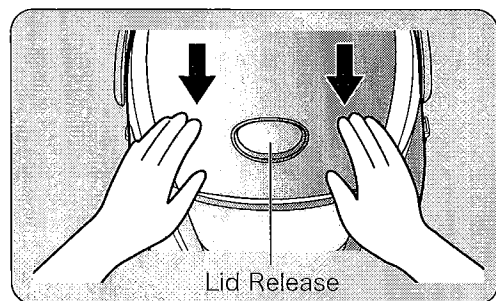

COOKING RICE

1 Select the type of rice and its texture by using the **MENU** button and the **TEXTURE** button.

- 1 Select the type of rice by pressing the **MENU** button.
 - Pressing the **MENU** button will move the ▲ mark and change the menu as shown.
- 2 Press the **TEXTURE** button to select rice texture.
 - The flashing menu setting indicates the current selection.
 - The texture options will vary depending on the type of rice selected. Please refer to charts on page 10 for type of rice and texture options.
 - Please refer to page 11, Tips for Cooking Rice.

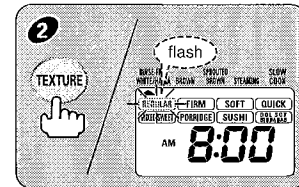
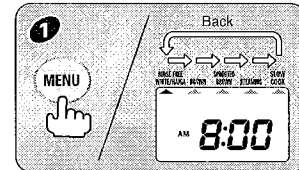
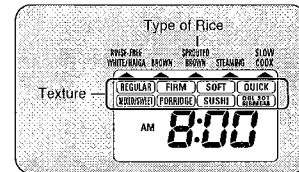

2 Press the **COOK/START** button.

- The **COOK** lamp lights and cooking begins.
- The display will show the current time.
- If the **COOK** lamp is not lit, press the **STOP/CANCEL** button to cancel cooking. Begin from step 1 above.
- The heating element will become very hot if the inner pot is not present inside the main unit.
- The remaining cooking time will be displayed beginning at 17 minutes. For PORRIDGE and SUSHI courses, it will be 10 minutes prior to completion. For DOL SOT BI BIM BAB course, 5 minutes prior to completion. For QUICK course, 12 minutes prior to completion.
- Steam will be released from the steam holes while rice is cooking.

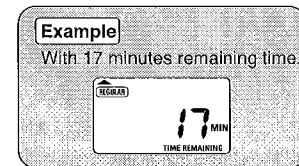
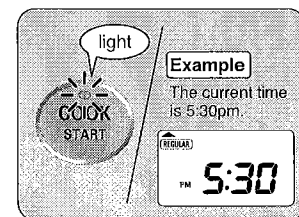

3 Stir the rice when cooking is finished.

- Indicator beeps will sound when cooking is finished and will automatically switch to the "Keep Warm" mode.
- The **KEEP WARM** lamp will light and the display will show the elapsed time that the rice has been in the "Keep Warm" mode.
- Do not unplug the appliance or remove inner lid while in the "Keep Warm" mode.
- Do not add rice or leave spatula inside inner pot while the rice is in the "Keep Warm" mode.
- Please refer to chart on page 10 for types of rice that can be kept warm.

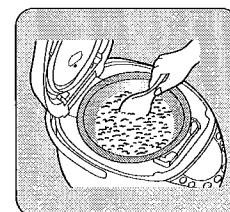
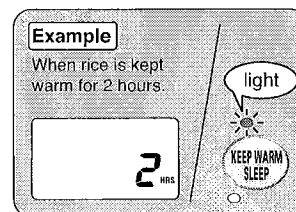

4 Press the **STOP/CANCEL** button and unplug the appliance after use.

- When the **STOP/CANCEL** button is pressed, the display will return to the menu showing the most recent rice texture selected.
- Press the **STOP/CANCEL** button and unplug the power cord after use. If this is not done, the appliance will enter the "Keep Warm" mode when it's plugged in the next time.

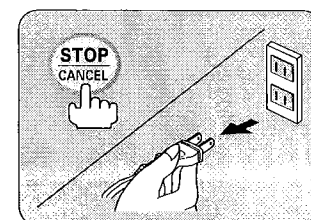

COOKING RICE

TYPE OF RICE AND KEEP WARM CHART

Menu/Texture	Regular	Firm	Soft	Quick	Mixed/Sweet	Porridge	Sushi	Dol sot bi bim bab
White	○	○	○	○	△	●	○	△
Rinse-Free	○	○	○	○	△	●	○	△
Brown	△	△	△	Can not cook		●	Can not cook	
Sprouted Brown	△	△	△			●		
Haiga	△	△	△	△	△	●	△	△

○ : Can keep warm.

△ : Do not keep warm as rice may develop an odor, turn yellow, or dry out.

● : Can not keep warm.

APPROXIMATE RICE COOKING TIMES (in minutes) (At room temperature 68°F/20°C and water temperature 64°F/18°C)

Menu/Texture	Regular	Firm	Soft	Porridge	Quick	Mixed	Sweet	Sushi
Capacity(cups)	1 - 5	1 - 5	1 - 5	0.5 - 1.5	1 - 5	1 - 3	1 - 3	1 - 5
White/Rinse-Free/Haiga	43 - 48	42 - 46	48 - 58	71 - 81	28 - 35	47 - 50	45 - 48	35 - 39
Capacity(cups)	1 - 4	1 - 4	1 - 4	0.5 - 1.5	Can not cook			
Brown	67 - 71	62 - 65	72 - 73	98 - 105				
Sprouted Brown	49 - 52	44 - 51	54 - 57	71 - 81				

RICE COOKING CHART

Menu/Texture	Regular	Firm	Soft	Quick	Mixed/Sweet	Porridge	Sushi	Dol sot bi bim bab
White/Rinse-Free/Haiga	◎	◎	◎	○	○	●	●	●
Brown	◎	◎	◎	Can not cook		●	Can not cook	
Sprouted Brown	○	○	○			●		

◎ : Variable Pressure Rice Cooking (Odoridaki) (1.2 Pressure ⇔ 1.0 Pressure) (Approx. 221°F/105°C ⇔ 212°F/100°C)
 ○ : Hi-Pressure Rice Cooking (1.2 Pressure, Approx. 221°F/105°C)
 ● : Unpressurized Rice Cooking (1.0 Pressure, Approx. 212°F/100°C)

HOW TO COOK DOL SOT BI BIM BAB

1 Place up to 4 cups of cooked rice into inner pot. Add the cooked ingredients of Dol Sot Bi Bim Bab on rice and stir gently.

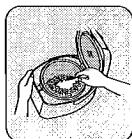

2 Press the **MENU** button to select **RINSE-FREE WHITE/HAIGA**.

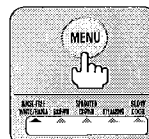

3 Press the **TEXTURE** button to select **DOL SOT BI BIM BAB**.



4 Press the **COOK/START** button. The **COOK** lamp lights and the cooking begins. Cooking takes approximately 12 to 20 minutes depending on temperature of the rice.



5 When cooking is finished, mix well and serve hot.

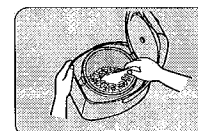

Note When cooking packaged convenience foods, follow the directions on package.

TIPS FOR COOKING RICE

- Evenly distribute the rice in the bottom of the inner pot to ensure even cooking.
- Wash the rice thoroughly. Newly harvested rice (fall season) usually requires less water for cooking than does rice that has been stored. As time goes by, rice has a tendency to become dehydrated, so more water is needed for cooking.

Note: Some brands of rice recommend not washing the rice before cooking to retain vitamins.

- Adjust the water level according to your own preference.
- The water level may be adjusted by up to 1/4 of a graduation level. If the amount of water is too great, it may boil over.

Example:
To cook 2 cups of rice.

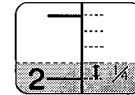

■ HOW TO COOK PORRIDGE

- The Porridge water lines in the inner pot are for cooking regular texture porridge. Adjust water level according to your own preference.
- Water Measurement Guidelines for Cooking Porridge:
Regular texture porridge:
Rice 1/2 cup, Water up to 0.5 cup mark.
Rice 1 cup, Water up to 1 cup mark.
Rice 1 1/2 cup, Water up to 1.5 cup mark.
Soft texture porridge:
Rice 1/2 cup, Water up to 1 cup mark.
- Select rice type from the menu. Select **PORRIDGE** from **TEXTURE**, and then begin cooking.

■ HOW TO COOK SUSHI RICE

- Cook white medium grain rice for sushi.
- Sushi course cooks rice that has a less sticky texture than normal, which is ideal for making sushi. If the rice is sticky type, add old rice to reduce stickiness.
- Measure water to the **SUSHI** line on inner pot.
- Select **WHITE/RINSE-FREE/HAIGA** from the menu. Select **SUSHI** from **TEXTURE**, and then begin cooking.

■ HOW TO COOK QUICK COURSE

- **QUICK** course is when you would like your rice cooked more quickly than a regular course.
- The rice may be slightly harder or may have a thin crust of rice form on the bottom of the inner pot.
- The rice may become softer if the rice is steamed a little longer in the "Keep Warm" mode after cooking.
- If softer rice is preferred, let the rice soak in water for at least 30 minutes before cooking.
- Measure water to the **WHITE/RINSE-FREE/HAIGA** line on inner pot.
- Select **WHITE/RINSE-FREE/HAIGA** from the menu. Select **QUICK** from **TEXTURE**, and then begin cooking.

■ HOW TO COOK RINSE-FREE RICE

- Measure water to the **RINSE-FREE** line on inner pot.
- Select **RINSE-FREE** from the menu. Select rice texture, and then begin cooking.

■ HOW TO COOK HAIGA RICE (short grain rice with nutritious rice germ)

- Measure water to the **HAIGA** line on inner pot.
- Select **HAIGA** from the menu.
- Select rice texture, and then begin cooking.

■ HOW TO COOK MIXED/SWEET RICE

- Wash rice and let sit until right before cooking.
- Mix all ingredients in a bowl.
- Excess ingredients may cause the rice to cook improperly.
- Use of seasonings when cooking rice causes the rice to burn more easily.
- Up to 3 cups of mixed rice or sweet rice can be cooked.
- Measure water to the **MIXED** or **SWEET** line on inner pot.
- Select **WHITE/RINSE-FREE/HAIGA** from the menu. Select **MIXED/SWEET** from **TEXTURE** and then begin cooking.
- After cooking rice mixed with other ingredients, a slight odor may remain. Wash the inner pot and inner lid thoroughly after each use.

■ HOW TO COOK BROWN RICE

- Up to 4 cups of brown rice can be cooked.
- Measure water to the **BROWN** line on inner pot.
- Select **BROWN** from the menu. Select rice texture, and then begin cooking.
- For more delicious results with brown rice, soak the rice in water for an hour or more before cooking.

■ HOW TO COOK SPROUTED BROWN RICE

- Mix washed white rice with sprouted brown rice.
- White rice to Sprouted Brown rice ratio: 2 cups of White rice to 1 cup of Sprouted Brown rice is the ideal ratio. Adjust the amount of rice based on personal preferences.
- Measure water to the **SPROUTED** line on inner pot.
- Select **SPROUTED BROWN** from the menu. Select rice texture, and then begin cooking.

TIMER COOKING

Rice cooking will be finished at a specific time when using Timer Cooking. Two times may be programmed using Timer Cooking.

1 Check that the current time is on the display. The rice cooker uses a 12-hour clock.

- If the clock has not been set to the correct time, Timer Cooking may not function properly.
- Timer Cooking will not work when the **COOK/START** lamp or **KEEP WARM** lamp is on. Press the **STOP/CANCEL** button to turn off the **COOK/START** lamp.

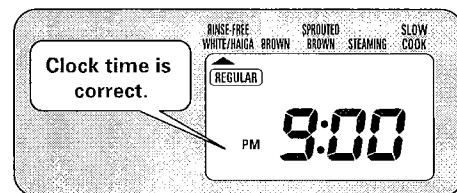

2 Select the type of rice and its texture by using the **MENU** button and the **TEXTURE** button.

- 1 Select the type of rice by pressing the **MENU** button.
 - Pressing the **MENU** button will move the ▲ mark and change the menu as shown.
- 2 Press the **TEXTURE** button to select rice texture.
 - The flashing menu setting indicates the current selection.
 - The texture options will vary depending on the type of rice selected.
 - Do not use Timer Cooking when the rice has seasoning or ingredients like MIXED or SWEET. The ingredients might sour or the rice might not be able to be cooked because of the seasoning sedimentation.

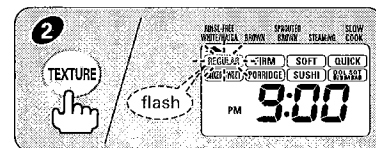
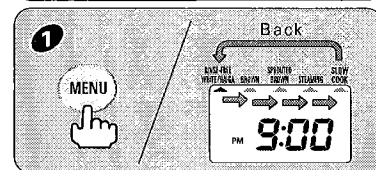
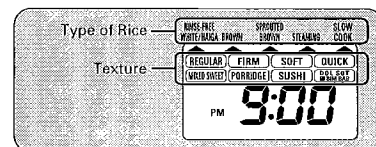

3 Select the time you would like the rice cooking to be completed.

- 1 Press the **TIMER** button.
 - The **TIMER** lamp will begin flashing.
- 2 Set the cooking timer using **HRS** button and **MIN** button.
 - **HRS** button can be set in 1 hour increments. **MIN** button can be set in 10 minute increments.
 - Two times may be programmed using **TIMER 1** and **TIMER 2**:
 - Each time the **TIMER** button is pressed, the display will alternate between **TIMER 1** and **TIMER 2**. Select the desired timer.
 - Timer cooking should be set to begin within 12 hours.
 - The cooked rice using Timer Cooking might be soft or scorched.

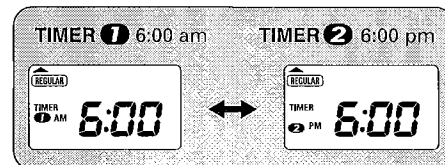
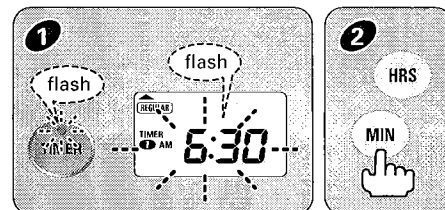

4 Press the **COOK/START** button.

- The **TIMER** lamp will stop flashing and the display will show the completion time.
- When cooking starts, the **TIMER** lamp turns off and then the **COOK** lamp turns on.
- When the **COOK/START** button is pressed and the inner lid is not attached, indicator beeps sound and the **COOK/START** button will not work.
- To turn off the indicator beeps, please refer to page 7.

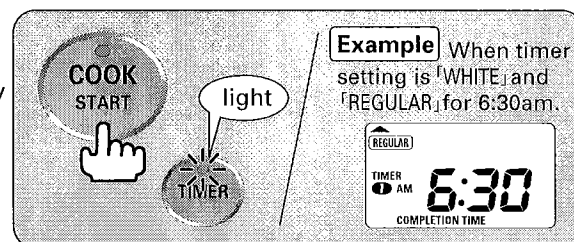

TIMER COOKING

Once the timer has been set, Timer Cooking can be performed in two steps.

- 1 Press the **TIMER** button to confirm MENU and TEXTURE selections.
- 2 Select TIMER 1 or TIMER 2 by pressing the **TIMER** button, and then pressing the **COOK/START** button.
 - Previous timer settings are stored in memory.

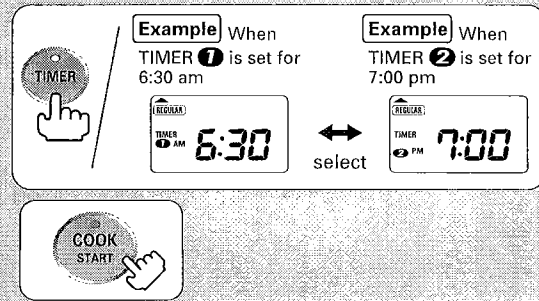

To change the settings for Timer Cooking:

First press the **STOP/CANCEL** button and then repeat steps 2-4.

To view current time while using Timer Cooking:

Press the **HRS** or **MIN** button. The display shows the current time for 2 seconds.

TIMER SETTINGS

Timer must be set for the minimum times listed below, otherwise cooking will start immediately.

	White, Rinse-Free, Haiga Rice	Brown Rice	Sprouted Brown Rice
Regular/Firm/Soft	1 hour and 10 minutes	1 hour and 30 minutes	1 hour and 10 minutes
Porridge	2 hours	2 hours	
Quick	1 hour	Can not cook	
Mixed/Sweet	1 hour and 10 minutes		
Sushi	1 hour		
Dol Sot Bi Bim Bab	Can not set a timer		

IMPORTANT THINGS TO KNOW

If you have to open the lid during operation:

1. Make sure there is nobody near the lid.
2. Press **STOP/CANCEL** button to cancel cooking. Be aware that steam is released from the lid.
3. Wait approximately 4 minutes to make sure there is no more steam released from the lid. Press **LID RELEASE** to open the lid.
 - To reset cooking, please refer to COOKING RICE, pages 9-10.
 - In this case, cooking is being halted, causing rice cooking to take longer or rice may not be properly cooked.

Results of cooked rice:

- Slight scorching may form on the bottom of the inner pot.
- Use of seasonings when cooking rice causes the rice to burn more easily. This causes slight scorching which may form on the bottom of the inner pot.

Continuous usage of the appliance:

- Allow the appliance to cool to room temperature. If the appliance is hot, the rice may not be properly cooked.

Power failure while the unit is in operation (includes times during operation when the plug is pulled or a circuit breaker goes out):

- If the power fails momentarily, the appliance will return to the same mode it was in prior to the failure.
- In the event of a longer power outage, the following will occur once power is restored:

During Cooking	<ul style="list-style-type: none"> • Cooking will continue, however, the rice may not be properly cooked. • If a little cooking time remains, the appliance may switch to the KEEP WARM mode.
While rice is being Kept Warm	<ul style="list-style-type: none"> • The appliance will continue to keep the rice warm.
During Timer Operation	<ul style="list-style-type: none"> • The appliance will immediately begin cooking if the time has passed the cooking start time. • The rice may not be cooked by the exact time programmed with the timer.

KEEP WARM/SLEEP

When the rice must be kept warm for a long time (i.e., overnight), the appliance uses a slightly lower temperature than usual, in order to keep the rice moist and to prevent odors from developing. The appliance will resume heating to normal temperatures after 8 hours.

*"Keep Warm/Sleep" can work only during "Keep Warm" mode.

1 Stir the rice, making it level.

- The **KEEP WARM** lamp is lit while the appliance is in "Keep Warm" mode.
- When only a small amount of rice must be kept warm, the rice should be placed in the center of the inner pot.
- Do not add cold rice as this may cause rice to develop an odor.

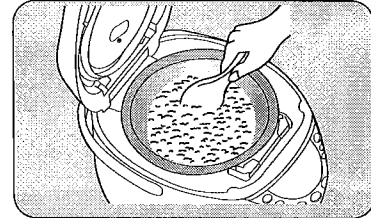

2 Close the outer lid and press the **KEEP WARM/SLEEP** button.

The **SLEEP** lamp turns on and switches to "Sleep" mode.

- Press the **STOP/CANCEL** button to cancel "Sleep" mode.
- Press the **KEEP WARM/SLEEP** button once more to switch back to "Keep Warm" mode. The display will show the elapsed warming time from 0 - hours.
- Even when the "Sleep" mode starts, the display shows the elapsed time from the starting time of "Keep Warm" mode.
- If the elapsed time for the "Keep Warm" function exceeds 24 hours, the "Keep Warm/Sleep" program will not operate.
- To view current time while using "Sleep" mode, press the **HRS** or **MENU** button. The display shows the current time for 2 seconds.

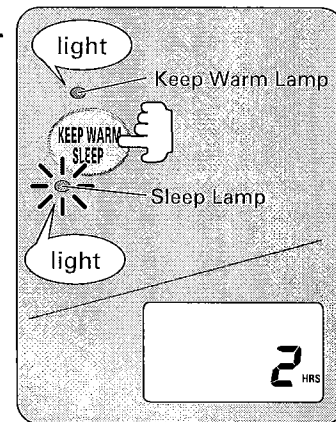

3 The "Sleep" operation lasts 8 hours.

- After 8 hours, the **SLEEP** lamp turns off and the **KEEP WARM** lamp remains on.
- The appliance will continue to display the elapsed time for the "Keep Warm" function. (The elapsed time includes 8 hours for the "Sleep" mode)
- If the elapsed time for the "Keep Warm" function exceeds 24 hours, the display will show the current time and the unit will continue the "Keep Warm" operation.
- Even if the elapsed time for the "Sleep" operation has not yet reached the 8-hour limit, if the elapsed time for the "Keep Warm" function exceeds 24 hours, the appliance will automatically revert to the standard "Keep Warm" mode. (The display will return to showing the current time.)

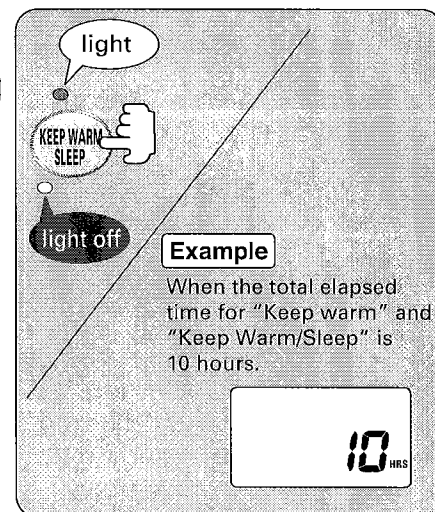

- Do not repeat the "Keep Warm/Sleep" operation more than one time for each batch of rice; as the rice may become discolored and develop an odor.
- Do not keep rice warm for more than 24 hours as rice may develop an odor, become discolored or dried out.

STEAMING

Select the **STEAMING** menu to steam food. The cooking times in chart below are approximate and should be used as a guideline.

1 Add approximately 1 1/2 measuring cups (9.13oz/270ml) of water into the inner pot.

- Use the measuring cup provided.
- Always add a minimum of one measuring cup of water.

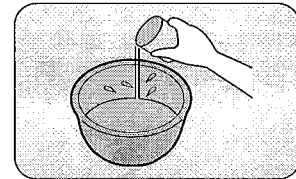

2 Place the inner pot into the main unit.

- Place the steaming plate in the inner pot.
- Place the food on the steaming plate.

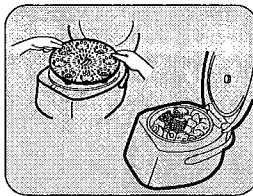

3 Close the outer lid and insert power plug into electrical outlet.

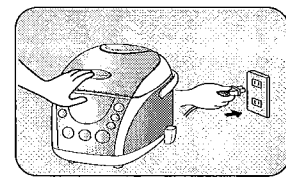

4 Press the **MENU** button to select **STEAMING**.

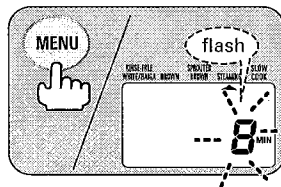

5 Set the steaming time using the **MIN** button.

- **MIN** button can be set for 8 - 58 minutes in 2 minute increments.



6 Press the **COOK/START** button.

- The **COOK** lamp lights and steaming begins.
- The display will show the remaining steaming time.
- When the time set is reached, indicator beeps will sound and unit will switch to the "Keep Warm" mode.
- Press **STOP/CANCEL** button and unplug the power cord after use.
- Some experimentation might be necessary to determine exact cooking times based on personal preferences for cooked vegetable tenderness or firmness.
- When water has completely evaporated, indicator beeps will sound and the time remaining display becomes 0. The **KEEP WARM** lamp will light and the unit will automatically switch from steaming to the "Keep Warm" mode.

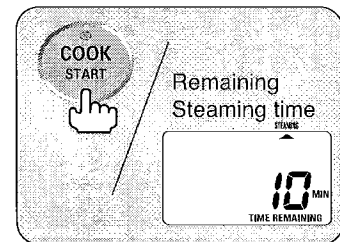

FOOD STEAMING CHART

Vegetable	Preparation	Quantity	Approx. Steaming Time
Artichokes	Cut in half	2-4	25-30 min.
Asparagus	Whole, stems trimmed	1 lb.	10-15 min.
Broccoli	Florets	1/2 lb.	10-15 min.
Beets	Peeled, cut into 1/4" slices	1 lb.	15-20 min.
Carrots	Cut, peeled	1 lb.	15-20 min.
Cauliflower	Florets	1 lb.	20-25 min.
Corn on the Cob	Husked, halved	2 med. ears	15-20 min.
Green Beans	Whole, trimmed	3/4 lb.	10-15 min.
Red Potatoes	Cut in half	1 lb.	25-30 min.
Snow Peas	Whole, trimmed	1/2 lb.	15-20 min.
Spinach	Leaves	1/2 lb.	8-10 min.
Sweet Potatoes or Yams	Cut in 1/2" pieces	1 lb.	20-25 min.
Zucchini	Cut in 1/4" rounds	1 lb.	10-15 min.
Eggs	Soft yolk (similar consistency to soft-boiled)	8	15 min.
	Hard yolk (similar consistency to hard-boiled)	8	23 min.

SLOW COOK

Select the **SLOW COOK** menu to make stew, soup or use slow cook recipes.

1 Put the ingredients and seasonings into the inner pot. Place it into the main unit.

- Do not add ingredients above the maximum **SLOW COOK/SOUP** line on inner pot. Doing so may cause the unit to overflow or the food may not be cooked properly.

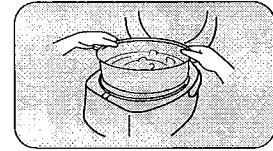

2 Close the outer lid and insert power plug into electrical outlet.

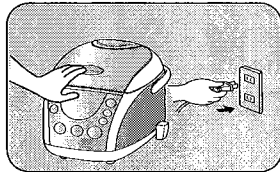

3 Press the **MENU** button to select **SLOW COOK**.

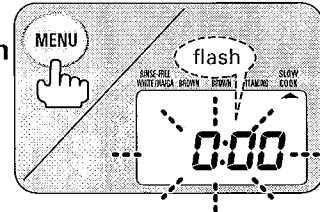

4 Press the **HRS** and **MIN** buttons to set the cooking time.

- HRS** button can be set for up to 8 hours in 1 hour increments.
- MIN** button can be set for up to 50 minutes in 10 minute increments.

Example: To set cooking time for 3 hours and 30 minutes.
Press **HRS** button to set 3 hours, then press **MIN** button to set 30 minutes.

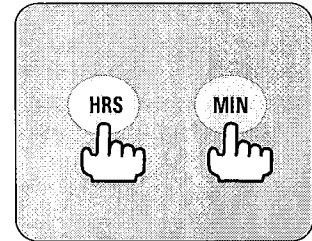

5 Press the **COOK/START** button.

- The **COOK** lamp lights and cooking begins.
- The display will show the remaining cooking time.
- When the time set is reached, indicator beeps will sound and the unit will switch to the "Keep Warm" mode.
- Press **STOP/CANCEL** button and unplug the power cord after use.
- Timer cooking can not be used for **SLOW COOK**.

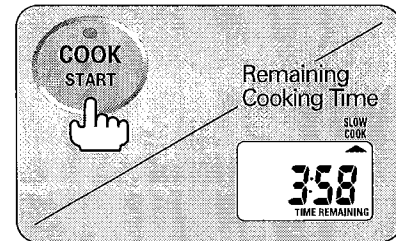

SPECIFICATIONS

Power Consumption		Cooking Capacity (Uncooked)		Dimensions				
Cooking	Keep Warm			Width	Depth	Height	Weight	Cord Length
650 W	28 Wh	White Rice	0.18~0.9 L (1~5 cups)	250mm (9 ¹³ / ₁₆ "	343mm (13 ¹ / ₂ "	229mm (9")	4.6 kg (10.2 lbs.)	Approx. 0.91m (35 ¹ / ₂ "
		Quick	0.18~0.9 L (1~5 cups)					
		Rinse-Free Rice	0.18~0.9 L (1~5 cups)					
		Haiga Rice	0.18~0.9 L (1~5 cups)					
		Sprouted Brown Rice	0.18~0.72 L (1~4 cups)					
		Brown Rice	0.18~0.72 L (1~4 cups)					
		Sweet Rice	0.18~0.54 L (1~3 cups)					
		Mixed Rice	0.18~0.54 L (1~3 cups)					
		Sushi Rice	0.18~0.9 L (1~5 cups)					
		Porridge	0.09~0.27 L (0.5~1.5 cups)					

CLEANING AND MAINTENANCE

- Always unplug the power cord from the electrical outlet and allow the unit to cool off completely prior to cleaning.
- When cleaning the unit, do not use cleaning powder, scrub brush, benzene or thinner.
- Do not wash Inner Pot, Steam Vent and Inner Lid in the dishwasher. This action may cause damage, discoloration or disfiguration.
- Attach the Steam Vent, Inner Lid, and Spatula Holder properly after each cleaning.

Steam Vent (upper surface of outer lid) *Make sure that the steam vent is washed after each use.

1. As shown in the figure, detach the steam vent by lifting it upward from the rear **1**.
2. Press the button **2** located on the front of the case, open the case, then rinse it with water.
*Do not remove the seal.
3. Align the hinge located at the rear and then close the case.
4. Attach the steam vent.

*Make sure that the steam vent has been inserted all the way to the bottom, by pushing down on the center of the steam vent.

Outer Lid/ Rice Cooker Main Unit
Wipe the main unit and outer lid clean, using a damp cloth.
*Do not use detergents.

Heating Element

Temperature Sensor
If any foreign material, such as rice grains, have become stuck to the sensor, polish the sensor lightly with fine sand paper (#320 grit) then wipe it clean with a damp cloth.

Lid Sensor
If the lid sensor becomes dirty, wipe it clean with a damp cloth.

Inner Lid Sensor
If any rice grains or foreign material clogs the sensor area, ensure that it is cleaned away.

Drip Receptacle
Excess moisture from the appliance may collect in the drip receptacle. Wipe the receptacle to ensure that any collected moisture is removed.

Latches
In the event that any foreign material, such as rice grains, enters these areas, ensure that such material is promptly removed. If too much foreign material begins to clog these areas, it may become difficult to open and close the outer lid and the lid may not latch properly.

Accessories

Wash accessories using a sponge and dishwashing detergent.

Inner Lid

***Wash inner lid after each use.**

Wash the inner lid using a sponge and dishwashing detergent.

Pressure Adjustment Filter / Pressure Adjustment Hole

To Detach:

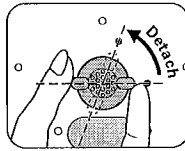

Pressure Adjustment Port

To Attach:

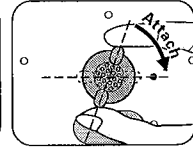
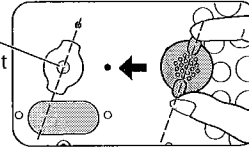

*Make sure that rice grains do not clog this hole. If clogging occurs, remove the rice grains using a skewer or a toothpick.

Negative Pressure Seal

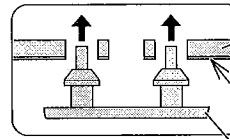

Inner Lid
Inner Pot side

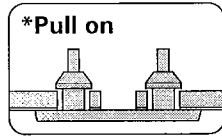

Negative Pressure Seal

Wash the inner lid with the seal attached. Do not pull on this seal.

Safety Valve

Depress the safety valve 2-3 times with your finger tip, to ensure that it moves smoothly and that no rice grains are stuck in the channel surrounding the shaft and spring.

If this area has become clogged, remove the rice grains using a skewer or a toothpick.

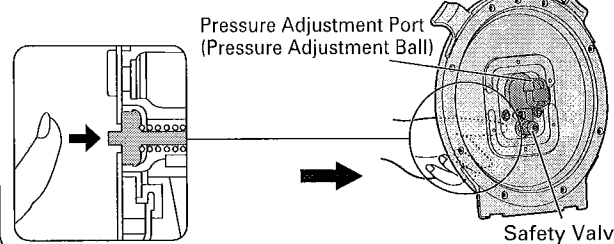

Inner Lid Seal

Wash the inner lid seal together with the inner lid. This seal is not removable, do not attempt to pull on it.

Inner Lid Tabs

Check that they are not bent or deformed.

Care and Maintenance for Inner Pot

Wash the inner pot using a sponge and dishwashing detergent.

CAUTION

- Make sure that the inner pot does not become deformed.
- Make sure that the following instructions are heeded, in order to avoid damaging the non-stick coating on the inner surface of the pot:
 - Do not wash rice in the inner pot using hard objects, such as whisks.
 - Always use the spatula that has been provided with the appliance.
 - Do not leave spoons or tableware in the inner pot.
 - Do not use vinegar for cleaning the pot.
 - Make sure that the inner pot is washed immediately after any rice with seasoning has been cooked.
- The inner pot may eventually become discolored during the course of normal usage. As any such discoloration is completely safe and will not affect the health at all, the pot may continue to be used without concern.
- Place the soft cloth underneath of the inner pot when the rice is washed in the inner pot. This will prevent from any damage on the bottom of the inner pot.
- Some discoloration of the outer side of the inner pot may occur through normal use. This discoloration is completely safe and poses no health hazard.

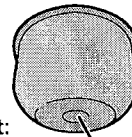

■ The center area on the outside bottom of the inner pot is an extremely important area, as it comes into direct contact with the temperature sensor. If this area is dirty or damaged, the rice may become scorched or burnt.

TROUBLESHOOTING

Check the following before requesting service.

Symptom	Possible Cause	Remedy
Outer lid is difficult to open.	Are any rice grains stuck in the latches or pressure adjustment port?	Remove any rice grains. See pages 17-18.
Outer lid does not close or can not attach the inner lid.	Is the inner lid attached properly?	Attach the inner lid properly. See page 6.
	Are any rice grains stuck in the latches?	Remove any rice grains. See page 17.
	Is the COOK lamp lit in red?	Press the STOP/CANCEL button. Wait approx. 4 minutes then close the outer lid. See page 13.
	Are the inner lid tabs damaged or deformed?	Do not use the appliance. Contact Sanyo Fisher Service for service. See page 24.
The control buttons won't work.	Is power cord plugged in properly?	Plug in the power cord.
	Is the inner lid attached properly?	Attach the inner lid. Otherwise, COOK/START or KEEP WARM/SLEEP function does not work. See pages 6 & 8.
Menu or Texture key function is disabled.	Is the correct menu and texture selected?	Refer to page 10 for the cooking Menu and Texture combinations.
Timer function won't work.	Is the time between the current time and preset time shorter than the actual cooking time?	Check the preset time. See page 13.
	Is the inner lid attached properly?	Attach the inner lid. The COOK/START button won't work without the inner lid attached. See pages 6 & 8.
Rice cooking does not complete at the preset time.	Is the current time set correctly?	Set current time correctly. See page 7.
Rice cooking takes too long (or too short).	Is the correct Menu and Texture selected? Is the water quantity correct?	Press the STOP/CANCEL button, and then reset the Menu and Texture after checking the water quantity.
The unit does not beep after cooking.	Is the "⚡" mark appearing on the LCD?	Set "⚡" mark off. See page 7.
There is noise in radio or TV.	Is the appliance too close to the radio or TV?	Maintain a distance more than 10' (3m).
There is noise during cooking.	The clicking sound is caused by the unit adjusting pressure while cooking. It is not a malfunction.	
	The sound is steam released from the steam vent during the pressure cooking. It is not a malfunction.	
The appliance smells resin.	Is the unit new?	The smells will lessen as the unit is used.
There are lines or connections on the plastic housing.	These are the connections between the housing parts. There is no trouble using it.	
Display is weak and the timer setting can not be maintained.	The battery is weak. Replace battery. Contact Sanyo Fisher Service. 800-421-5013 or visit www.sanyoservice.com .	

Possible Cause \ Symptom	Water boils over during cooking. Steam comes out from the outer lid.	Rice is hard, undercooked or soft.	Rice is scorched.	Rice becomes hard, discolored or develops an odor while in keep warm mode.	Reference Page #
Is the Inner Lid attached properly? Is the Outer Lid securely closed?	●	●		●	6, 8
Is the Steam Vent properly attached?	●			●	5, 8, 17
Is the rice and water amount correct?	●	●			8, 11
Is the correct Menu or Texture selected?	●	●	●		9, 10
Is there any damage on the Inner Lid Seal or Negative Pressure Seal?	●	●		●	18
Are there any foreign objects sticking to the Inner Lid Seal, Outer Inner Pot or Temperature Sensor?	●	●	●	●	4, 8, 17, 18
Is the rice washed thoroughly before cooking?	●		●	●	8, 11
Is the Outer Lid opened during cooking?		●			4, 13
Is the rice stirred thoroughly after cooking?		●		●	9, 14
Was seasoning used?			●	●	11, 12, 13
Was the rice kept warm more than 24 hours?				●	14
Was the rice kept warm with Spatula in inner pot? Was the cold rice kept warm or cold rice added?				●	9, 14
Is the power cord plugged in properly or has any power failure occurred?		●		●	13

RECIPES

TIPS FOR COOKING RECIPES

1. Use the provided measuring cup (6 oz. or 180 ml) for measuring rice.
2. Do not measure seasonings with the provided measuring cup. Use a standard measuring cup and spoons for seasonings.
3. Do not cook more than the unit allows for cooking certain types of rice or recipes.
4. Mix seasonings thoroughly such as soy sauce or salt with the broth, soup, or water, and add to inner pot right before cooking.
5. Excess ingredients or poor mixing of seasonings may cause the rice to cook improperly.
6. Use of seasonings when cooking rice causes the rice to burn more easily.
7. After cooking rice mixed with other ingredients, a slight odor may remain. Wash the inner pot and inner lid thoroughly after each use.

Rice with Meat and Vegetables (Kayaku Gohan)

MIXED RICE

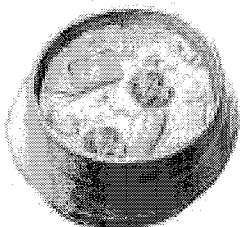

Makes 4-6 servings

Ingredients:

3 cups rice
1/3 cup burdock
1/3 cup chopped carrots
3 dried shiitake mushrooms
1.5 oz. yam cake (konnyaku)
1 sheet deep-fried tofu (abura-age)
2 oz. chicken
2 cups Japanese broth (dashi)
2 Tbs. light-colored soy sauce
3 Tbs. sake
1/2 tsp. salt
2 or 3 snow pea pods

Preparation:

1. Wash rice and let sit for 30-60 minutes.
2. Soak dried shiitake mushrooms in water and cut into thin strips.
3. Remove outer skin of the burdock, shred into fine strips, and soak in water.
4. Chop carrots into thin strips and cut chicken into small, bite-size pieces.
5. Cut yam cake into thin strips and boil briefly.
6. Briefly boil deep-fried tofu and cut into thin slices.
7. Make seasoning by adding soy sauce, sake, and salt to the Japanese broth (dashi) and mix well.
8. Drain rice and pour into inner pot. Add enough seasoning prepared in step ⑦ to fill up to **3** on the **WHITE/MIXED** water level line. Then mix ingredients from steps ② through ⑥ and place on top of rice.
9. Close outer lid and select **RINSE-FREE/WHITE/HAIGA** with the **MENU** button. Press the **TEXTURE** button and select **REGULAR**. Press the **COOK/START** button.
10. Briefly boil snow peas in salted water and cut into thin strips.
11. When rice is cooked, stir the rice. Place in bowl and garnish with snow pea pods.

Teriyaki Mushroom Sprouted Brown Rice

SPROUTED BROWN RICE



Makes 4-6 servings

Ingredients:

2 cups rice
1 cup sprouted rice
1 can (3 oz.) chunk chicken breast, break into small pieces
1 can (7 oz.) mushroom pieces & stems
1/2 can (10 1/2 oz.) condensed French onion soup
1 Tbs. sugar
4 Tbs. soy sauce
3 Tbs. butter or margarine

Preparation:

1. Wash rice and let sit for one hour.
2. Break chunk chicken breast into small bite sizes.
3. Drain rice and pour into inner pot. Add ②, the remaining ingredients and water up to **3** on the **WHITE/MIXED** water level line and mix well.
4. Close outer lid and select **SPROUTED BROWN** with the **MENU** button. Press the **TEXTURE** button and select **REGULAR**. Press the **COOK/START** button.
5. After approx. 20 minutes into cooking, carefully open the lid, quickly stir the rice, and close the lid. Continue cooking until rice is done.
6. When rice is cooked, stir the rice gently and place in bowl.

Seasoned Brown Rice

BROWN RICE

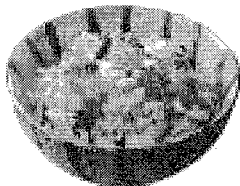

Makes 6 servings

Ingredients:

3 cups long-grain brown rice
2 cans (10.5 oz.) chicken broth
3 Tbs. margarine
1/2 tsp. crushed garlic (from jar)
1 tsp. dried parsley

Preparation:

1. For better results, wash brown rice and let sit for 2 hours.
2. Drain rice and pour into inner pot.
3. Add chicken broth, margarine and crushed garlic into inner pot and water up to **3** on the **BROWN** water level line and mix well.
4. Close outer lid and select **BROWN** with the **MENU** button. Press the **TEXTURE** button and select **REGULAR**. Press the **COOK/START** button.
5. When rice is cooked, add dried parsley and stir the rice gently. Add 1 teaspoon of Poultry Seasoning, if desired.

Rice with Red Beans (Sekihan)

SWEET RICE

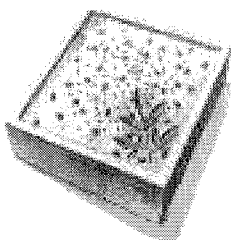

Makes 4-6 servings

Ingredients:

2 cups sweet rice (rice for making rice dumplings)
1 cup rice
1/2 cup red beans (azuki)
1 tsp. black sesame salt (gomashio)

Preparation:

1. Mix the two kinds of rice together, wash, and let sit for 30-60 minutes.
2. Heat red beans in a pot of water over strong flame. Bring to a boil and discard broth. Add another half quart of water and simmer until beans are slightly hard.
3. When red beans are cooked, separate beans from broth. Scoop broth with ladle and pour back into pot four or five times to air broth.
4. Drain rice and pour into inner pot. Add broth from step ③ and water up to **3** on the **SWEET** water level line. Place red beans on top of rice.
5. Close outer lid and select **RINSE-FREE/WHITE/HAIGA** with the **MENU** button. Press the **TEXTURE** button and select **MIXED/SWEET**. Press the **COOK/START** button.
6. When rice is cooked, stir the rice gently and place in bowl. Sprinkle with the black sesame salt.

Shrimp Pilaf

PILAF



Makes 4-6 servings

Ingredients:

3 cups rice
6 medium size shrimp (or 1/4 cup cocktail shrimp)
6 1/2 oz. can chopped clams, (optional, save the juice)
1/4 cup mixed vegetables (frozen or canned)
3 Tbs. olive oil
2 tsp. chicken bouillon
2 cups water
1/2 tsp. curry powder
Salt & pepper

Preparation:

1. Wash rice and drain well.
2. Cook shrimp in boiling water for 2-3 minutes. Peel and cut into bite-size pieces.
3. Heat 2 Tbs. olive oil in skillet. Sauté drained rice until rice becomes transparent. Remove from skillet and set aside.
4. Heat 1 Tbs. olive oil in skillet. Sauté chopped shrimp from step ②, clams or other seafood, and mixed vegetables. Season with salt, pepper, and curry powder.
5. Dissolve chicken bouillon in 2 cups of water. If the juice from the can of clams is available, reduce the water to make 2 cups of liquid.
6. Place the sautéed rice in step ③ into inner pot. Add the liquid from step ⑤ and enough water to fill up to **3** on the **WHITE/MIXED** water level line. Then place sautéed seafood from step ④ on top of rice.
7. Close outer lid and select **RINSE-FREE/WHITE/HAIGA** with the **MENU** button. Press the **TEXTURE** button and select **MIXED/SWEET**. Press the **COOK/START** button.
8. When rice is cooked, fluff the rice and serve.

Risotto

PORRIDGE



Makes 4-6 servings

Ingredients:

1 cup rice
1/2 medium onion, minced
4 stalks asparagus
1 clove garlic, minced
1/2 cup canned tuna (optional)
1 Tbs. olive oil
2 tsp. chicken bouillon
Salt & pepper
3 1/4 cups water

Preparation:

1. Wash rice and drain well.
2. Mince onion and garlic.
3. Cut asparagus diagonally into bite-size pieces and parboil. Drain and set aside.
4. Dissolve chicken bouillon in 3 1/4 cups of water.
5. Heat 1/2 Tbs. of olive oil in skillet. Sauté minced garlic well to bring out the flavor. Add minced onion and sauté well. Add tuna and season with salt and pepper. Remove from skillet and set aside.
6. Heat 1/2 Tbs. olive oil in skillet. Sauté drained rice in step ① until rice becomes transparent.
7. Place the sautéed rice in step ⑥ into inner pot. Add liquid from step ④ to fill up to 1 on the **PORRIDGE** water level line. Then place sautéed garlic, onion, and tuna from step ⑤ on top of rice.
8. Close outer lid and select **RINSE-FREE/WHITE/HAIGA** with the **MENU** button. Press the **TEXTURE** button and select **PORRIDGE**. Press the **COOK/START** button.
9. When rice is cooked, add parboiled asparagus from step ③ and mix well. Let it steam for a few minutes before serving.

Tangy Garlic Chicken

SLOW COOK

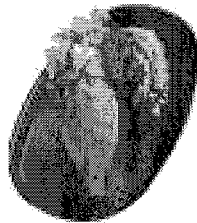

Makes 3-4 servings

Ingredients:

4 skinless, boneless chicken breast halves
1 tsp. salt
2 tsp. paprika
2 tsp. lemon pepper
1 large onion, sliced
10 garlic gloves (about 1 medium) peeled, but not chopped

Preparation:

1. Rinse chicken breasts and pat dry.
2. Mix together all dry seasonings.
3. Rub dry seasonings on chicken breasts.
4. Slice onion into thin slices.
5. Place sliced onions on bottom of inner pot.
6. Place seasoned breasts on top of onions.
7. Place garlic gloves on top of chicken breasts.
8. Close outer lid and select **SLOW COOK** with the **MENU** button. Set the time to cook for approximately 2 to 2 1/2 hours, depending on thickness of breasts. Press the **COOK/START** button.
9. The chicken is done when it reaches a minimum of 165° F.

French Onion Soup

SOUP



Makes 4 servings

Ingredients:

3 large onions, thinly sliced
1/2 cup butter or margarine
2 Tbs. instant beef bouillon cubes
4 cups hot water
1 tsp. worcestershire sauce
1/2 tsp. salt
4 slices toasted French bread
1/4 cup grated Parmesan cheese

Preparation:

1. In large skillet, cook onions in butter until lightly browned.
2. Mix hot water with beef bouillon cubes until dissolved.
3. Add cooked onions, butter, bouillon water, worcestershire sauce, and salt to Inner Pot and place in main unit.
4. Close outer lid and select **SLOW COOK** with the **MENU** button. Set time to cook for approximately 3 hours. Press the **COOK/START** button.
5. Top each bowl with toasted French bread sprinkled with Parmesan cheese.

California Roll (Inside Out)

SUSHI

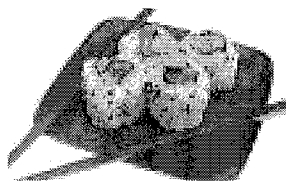

Makes 4-6 servings

Ingredients:

3 cups white rice (short or medium grain)
1/3 cup rice vinegar
3 Tbs. sugar
1 tsp. salt
4 sheets of dried seaweed
1 avocado
1 cucumber
1 cup crab meat (or imitation crab meat)
Mayonnaise
Toasted sesame seeds
Wasabi (green mustard)

Preparation:

1. Wash rice and drain well.
2. Pour rice into inner pot. Add water up to **3** on the **WHITE/MIXED** water level line.
3. Close outer lid and select **RINSE-FREE/WHITE/HAIGA** with the **MENU** button. Press the **TEXTURE** button and select **SUSHI**. Press the **COOK/START** button.
4. Peel and slice avocado and cucumber in strips.
5. Transfer cooked rice to a large bowl. Combine rice vinegar, sugar and salt in a bowl. Sprinkle the vinegar mixture over the rice and gently fold with spatula.
6. Lay 1/2 sheet of seaweed on bamboo mat. With damp hands spread a thin layer of sushi rice over the entire sheet of seaweed and press firmly. Lift sushi sheet from mat, place damp kitchen towel on mat, turn the sushi sheet over on the damp towel so that the seaweed is facing up.
7. Place cucumber, avocado, mayonnaise, wasabi and crab meat lengthwise on the seaweed.
8. Roll the bamboo mat and towel forward, pressing the ingredients inside. Press the roll firmly with your hands shaping a tight cylinder. Pull off towel carefully.
9. Sprinkle with sesame seeds and cut into eight pieces with a sharp knife.

Dol Sot Bi Bim Bab

DOL SOT BI BIM BAB



Makes 4-6 servings

Ingredients:

3 cups cooked rice
1/4 lb. thin sliced or ground beef
1/2 bunch spinach
1/2 lb. bean sprouts
1 medium carrot
1 Tbs. sugar
1 Tbs. soy sauce
1 Tbs. minced green onion
1 tsp. crushed garlic
1 Tbs. ground sesame seeds
2 1/2 Tbs. sesame oil
2-3 eggs, fried over-easy or sunny-side up
1/2 Tbs. Ko-chu-jang, Korean chili bean paste (available in Korean grocery)

Preparation:

1. In a bowl, combine 1 Tbs. sugar, 1 Tbs. soy sauce, 1 Tbs. minced green onion, and 1 tsp. crushed garlic. Marinate beef in the mixture for one hour. Heat 1/2 Tbs. sesame oil in skillet. Cook beef until browned and liquid is absorbed.
2. Cut carrot into fine strips. Boil carrot, spinach, and bean sprouts individually until vegetables are tender. Drain and squeeze out water. Cut spinach into 1-inch pieces. Season each individually boiled vegetable with 1 tsp. ground sesame seeds and 1 tsp. sesame oil.
3. Spread 1 Tbs. sesame oil in inner pot. Add cooked rice into inner pot. Arrange seasoned vegetables from step ② and meat from step ① over the rice.
4. Close outer lid and select **RINSE-FREE/WHITE/HAIGA** with the **MENU** button. Press the **TEXTURE** button and select **DOL SOT BI BIM BAB**. Press the **COOK/START** button.
5. After cooking is done, add fried eggs and Ko-chu-jang. Mix well and serve hot.

Tips for making Ko-chu-jang (Korean chili bean paste)

Ingredients:

1/3 cup soy sauce
1/2 cup miso, soy bean paste
1/4 cup sugar
1/2 tsp. salt
1/2 tsp. cayenne pepper powder

Preparation:

In a sauce pan, cook soy sauce, miso, and sugar. Mix well and remove from heat when it starts bubbling. Add salt and cayenne pepper to taste. Allow to cool.

SANYO RICE COOKER/WARMER ECJ-PX50S LIMITED WARRANTY

OBLIGATIONS

In order to obtain factory warranty service, call the toll-free number below. The unit must be packed in the original carton or a well-padded sturdy carton in order to avoid shipping damage.

Note: Do not return this unit to the retail store for service.

To obtain factory warranty service, product operation information or for problem resolution, call
1-800-421-5013
Weekdays 8:00 AM – 5:00 PM Pacific Time
Or visit web at www.sanyoservice.com

THIS WARRANTY IS VALID ONLY ON SANYO PRODUCTS PURCHASED AND USED IN THE UNITED STATES OF AMERICA. THIS WARRANTY APPLIES ONLY TO THE ORIGINAL RETAIL USER AND DOES NOT APPLY TO PRODUCTS USED FOR ANY INDUSTRIAL, PROFESSIONAL OR COMMERCIAL PURPOSE. THE ORIGINAL DATED BILL OF SALE OR SALES SLIP MUST BE SUBMITTED TO THE AUTHORIZED SANYO SERVICE CENTER AT THE TIME WARRANTY SERVICE IS REQUESTED.

Subject to the OBLIGATIONS above and EXCLUSIONS below, SANYO FISHER COMPANY (SFC) warrants this SANYO product against defects in materials and workmanship for the periods of LABOR and PARTS specified below. SFC will repair or replace (at its option) the product and any of its parts which fail to conform to this warranty. The warranty period commences on the date the product was first purchased at retail.

LABOR	PARTS
1 YEAR	1 YEAR

EXCLUSIONS

This warranty does not cover (A) the adjustment of customer-operated controls as explained in the appropriate model's instruction manual, or (B) the repair of any product whose serial number has been altered, defaced or removed.

This warranty shall not apply to setup, installation, removal or the product for repair or reinstallation of the product after repair.

This warranty does not apply to repairs or replacements necessitated by any cause beyond the control of SFC including, but not limited to, any malfunction, defect or failure caused by or resulting from unauthorized service or parts, improper maintenance, operation contrary to furnished instructions, shipping or transit accidents, modification or repair by the user, abuse, misuse, neglect, accident, incorrect power line voltage, fire, flood or other Acts of God, or normal wear and tear.

The foregoing is in lieu of all other expressed warranties and SFC does not assume or authorize any party to assume for it any other obligation or liability.

THE DURATION OF ANY WARRANTIES WHICH MAY BE IMPLIED BY LAW (INCLUDING THE WARRANTIES OF MERCHANTABILITY AND FITNESS) IS LIMITED TO THE TERM OF THIS WARRANTY. IN NO EVENT SHALL SFC BE LIABLE FOR SPECIAL, INCIDENTAL OR CONSEQUENTIAL DAMAGES ARISING FROM OWNERSHIP OR USE OF THIS PRODUCT, OR FOR ANY DELAY IN THE PERFORMANCE OF ITS OBLIGATIONS UNDER THIS WARRANTY DUE TO CAUSES BEYOND ITS CONTROL. SOME STATES DO NOT ALLOW LIMITATIONS ON HOW LONG AN IMPLIED WARRANTY LASTS AND/OR DO NOT ALLOW THE EXCLUSION OR LIMITATION OF CONSEQUENTIAL DAMAGES, SO THE ABOVE LIMITATIONS AND EXCLUSIONS MAY NOT APPLY TO YOU.

THIS WARRANTY GIVES YOU SPECIFIC LEGAL RIGHTS. YOU MAY HAVE OTHER RIGHTS, WHICH VARY FROM STATE TO STATE.

For your protection in the event of theft or loss of this product, please fill in the information below for your own personal records.

Model No. _____ Serial No. _____

(Located on back or bottom side of unit)

Date of Purchase _____ Purchase Price _____

Where Purchased _____

Free Manuals Download Website

<http://myh66.com>

<http://usermanuals.us>

<http://www.somanuals.com>

<http://www.4manuals.cc>

<http://www.manual-lib.com>

<http://www.404manual.com>

<http://www.luxmanual.com>

<http://aubethermostatmanual.com>

Golf course search by state

<http://golfingnear.com>

Email search by domain

<http://emailbydomain.com>

Auto manuals search

<http://auto.somanuals.com>

TV manuals search

<http://tv.somanuals.com>