

## PARTS LIST

## Vacuum Cleaner

## SC-KT17 (U.S.A.)

### Specifications

Power source	: AC 120 V 60 Hz	
Power consumption	: 5.5 A	
Motor revolution	: 32,500 r.p.m.	
Vacuum	: 2,000 mmAq	
Dimensions	(Handy)	(Upright)
L X W X H	13 - 19/32" X 7 - 3/32" X 8 - 27/32"	14 - 3/16" X 11 - 13/16" X 43 - 5/16"
	(354 X 180 X 225 mm)	(360 X 300 X 1,100 mm)
Net weight	: 8 lbs. 6 ozs. ( 3.8 Kg )	
Attachment	: Hose, Floor nozzle, Extension pipe, Crevice tool	

PRODUCT CODE NO.

1 - 326 562 57 ( P )

### Wiring Diagram

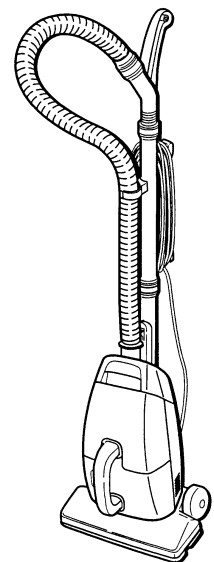
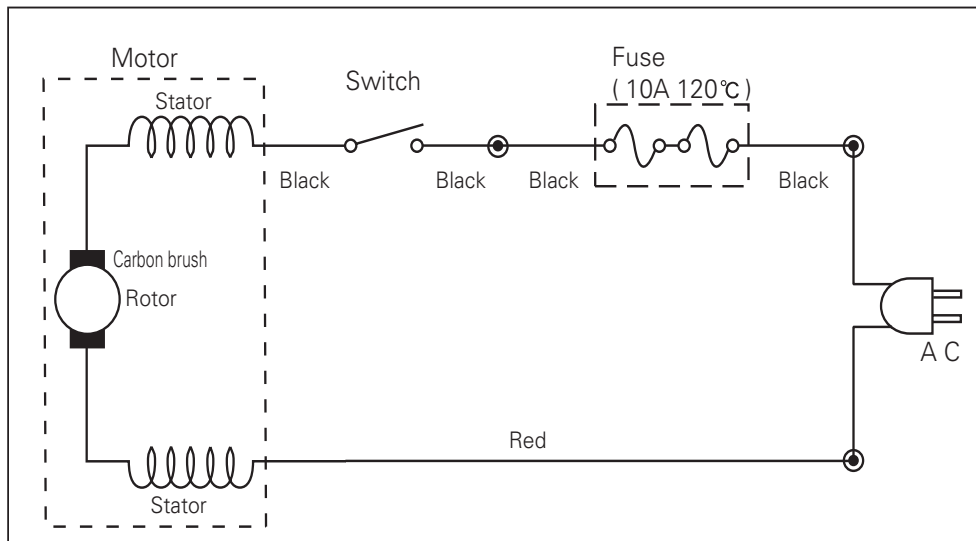

**Exploded View  
(Main unit)**

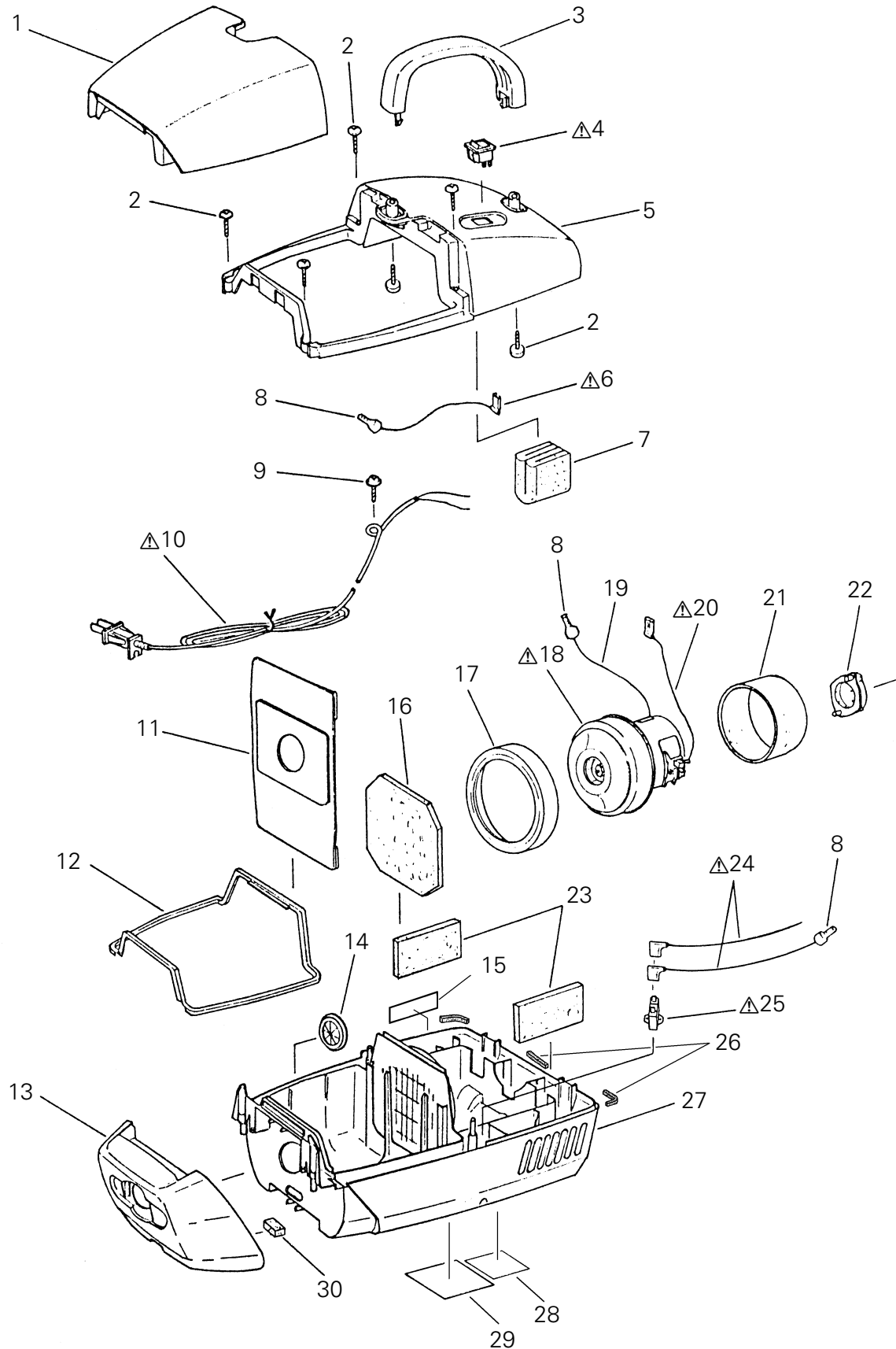

NOTE: The parts marked with  $\triangle$  have special characteristics of safety, if replace the  $\triangle$  mark parts, use only SANYO specified parts.

**SC-KT17 (U.S.A.)**

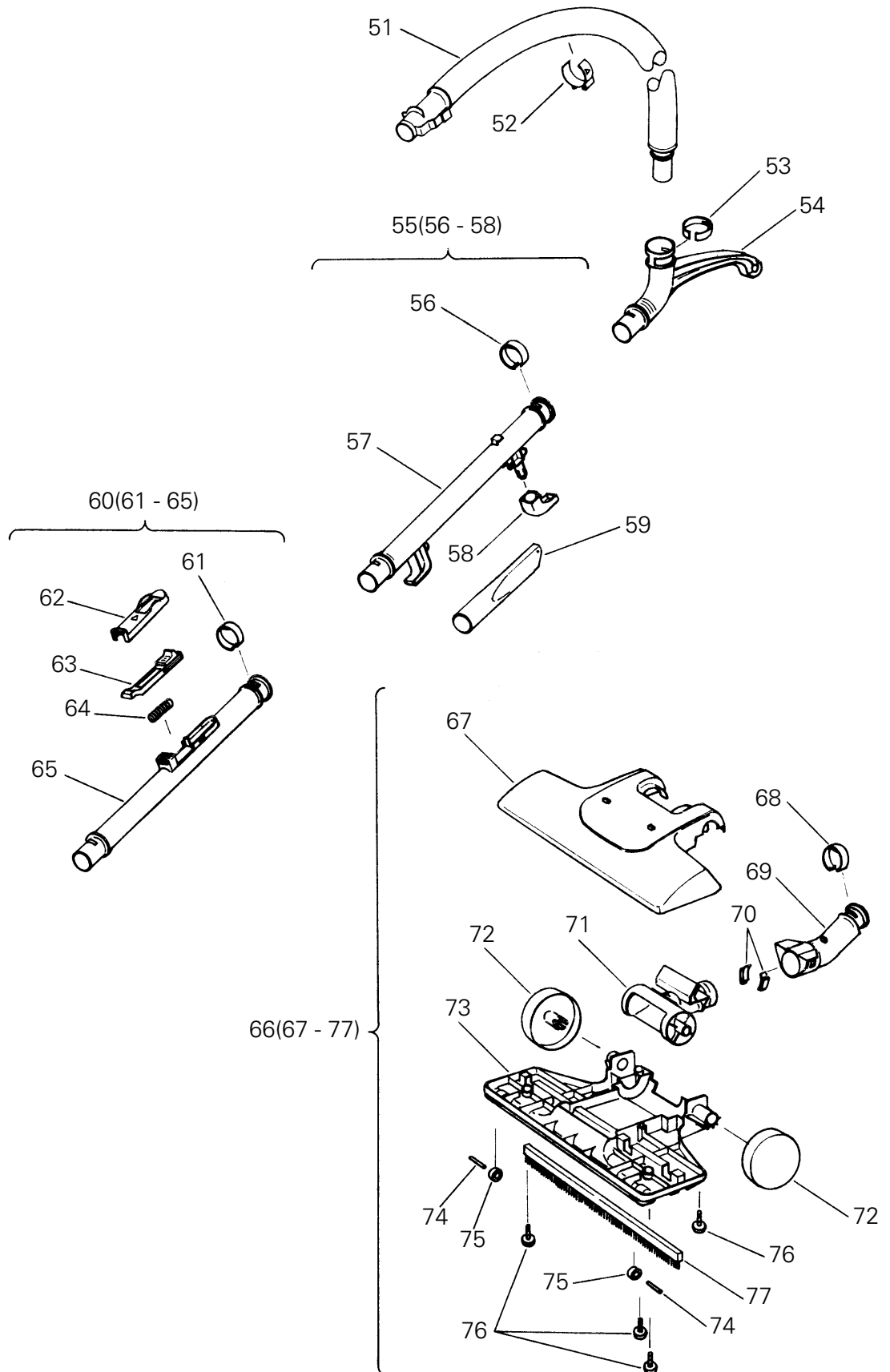











# Parts List

NOTE: The parts marked with  have special characteristics of safety,  
if replace the  mark parts, use only SANYO specified parts.

**SC-KT17 (U.S.A.)**

Key No.	Parts No.	Description	Q'ty	Key No.	Parts No.	Description	Q'ty
	(Main unit)				(Attachment)		
1	649 000 4610	DUST BOX COVER (P-141)	1	51	649 000 3347	HOSE ASSEMBLY (L=750)	1
2	411 006 8301	SCR TPG PAN 4X20	6	52	649 000 3354	HOSE HOLDER (NN-B)	1
3	649 000 3132	HANDLE (NN-B)	1	53	649 000 4665	ROTARY BEND SET RING	1
	4 649 000 3149	SWITCH	1	54	649 000 3378	GRIP (NN-B)	1
5	649 000 4627	CASE UPPER (P-141)	1	55	649 000 4672	EXTENSION PIPE ASSEMBLY B KEYNO.56-58	1
	6 649 000 3163	CORD ASSEMBLY (BLACK) L=300	1	56	649 000 4689	PIPE SET RING (P-141)	1
7	649 000 2586	SUB-FILTER	1	57	649 000 3408	EXTENSION PIPE B (NN-B)	1
8	649 000 0520	WIRE CONNECTOR (CE-230)	3	58	649 000 3415	CORD STORAGE HOOK (NN-B)	1
9	649 000 2654	SCREW 4X16	1	59	649 000 3422	CREVICE TOOL (NN-B)	1
	10 649 000 3170	POWER CORD (UL)	1	60	649 000 4696	EXTENSION PIPE ASSEMBLY A KEYNO.61-64	1
11	649 000 4634	PAPER BAG (SC-P11)	1	61	649 000 4689	PIPE SET RING (P-141)	1
12	649 000 3194	DUST BOX PACKING	1	62	649 000 3446	PIPE COVER (NN-B)	1
13	649 000 3200	FRONT COVER (NN-B)	1	63	649 000 4702	BUTTON (PIPE) (P-141)	1
14	649 000 3217	AIR INLET PACKING (NN-B)	1	64	649 000 3460	CLAMP SPRING	1
15	649 000 3811	CAUTION LABEL	1	65	649 000 3477	EXTENSION PIPE A (NN-B)	1
16	649 000 3224	ELECTROSTATIC MICRON FILTER	1	66	649 000 4719	FLOOR NOZZLE COMP. KEYNO.67-77	1
17	649 000 3231	MOTOR CUSHION FRONT	1	67	649 000 4726	FLOOR NOZZLE CASE (P-141)	1
	18 649 000 3774	MOTOR COMP. (AC 120V)	1	68	649 000 4689	PIPE SET RING (P-141)	1
	649 000 3255	CARBON BRUSH ASSEMBLY	2	69	649 000 3507	ROTARY BEND (NN-B)	1
19	649 000 3262	LEAD WIRE (RED) L=250	1	70	649 000 3514	BEND SET PIECE (NN-B)	2
	20 649 000 3279	CORD ASSEMBLY (BLACK) L=350	1	71	649 000 3521	ROTARY PIPE (NN-B)	1
21	649 000 3286	SILENCER PIPE	1	72	649 000 3538	FLOOR NOZZLE ROLLER (NN-B)	2
22	649 000 3293	MOTOR CUSHION REAR	1	73	649 000 3545	FLOOR NOZZLE BASE (NN-B)	1
23	649 000 3798	OUTLET FILTER	2	74	649 000 3552	SHAFT FRONT	2
	24 649 000 1800	CORD ASSEMBLY (BLACK) L=200	2	75	649 000 4733	WHEEL SMALL ASSEMBLY (NN-B)	2
	25 649 000 3606	FUSE ASSEMBLY (10A 120°C)	1	76	411 007 0700	SCR TPG TRS 4X16	4
26	649 000 0643	AIR SPREADER G	3	77	649 000 3576	BRUSH BASE ASSEMBLY	1
27	649 000 3316	CASE LOWER (NN-B)	1				
28	649 000 4641	STICKER	1				
29	649 000 4658	NAME PLATE	1				
30	649 000 3330	INDICATOR FILTER	1				

COLOR CODE:P-141(PINK),NN-B(BLACK)

For Parts or Service Contact  
SANYO FISHER SERVICE CORPORATION.  
21605 Plummer Street,  
Chatsworth, CA 91311

## Free Manuals Download Website

<http://myh66.com>

<http://usermanuals.us>

<http://www.somanuals.com>

<http://www.4manuals.cc>

<http://www.manual-lib.com>

<http://www.404manual.com>

<http://www.luxmanual.com>

<http://aubethermostatmanual.com>

Golf course search by state

<http://golfingnear.com>

Email search by domain

<http://emailbydomain.com>

Auto manuals search

<http://auto.somanuals.com>

TV manuals search

<http://tv.somanuals.com>