

SCAG[®]

POWER EQUIPMENT

MODEL GC-STT



THIS MANUAL CONTAINS THE OPERATING INSTRUCTIONS AND SAFETY INFORMATION FOR YOUR SCAG ACCESSORY. READING THIS MANUAL WILL PROVIDE YOU WITH MAINTENANCE AND ADJUSTMENT PROCEDURES TO KEEP YOUR ACCESSORY PERFORMING TO MAXIMUM EFFICIENCY. THE SPECIFIC MODELS THAT THIS BOOK COVERS ARE CONTAINED ON THE INSIDE COVER. BEFORE OPERATING YOUR MACHINE, PLEASE READ ALL THE INFORMATION ENCLOSED.

OPERATOR'S MANUAL

PART NUMBER 03138



WARNING

FAILURE TO FOLLOW SAFE OPERATING PRACTICES MAY RESULT IN SERIOUS INJURY.

- * Keep all safety shields in place.
- * Before performing any maintenance or service, stop the machine and remove the spark plug wire.
- * If a mechanism becomes clogged, stop the engine and wait for all moving parts to come to a complete halt before cleaning.
- * Keep hands, feet and clothing away from power-driven parts.
- * Read this manual completely as well as the Operator's Manual that came with your mower.
- * Keep others off the tractor (only one person at a time).

REMEMBER - YOUR MOWER IS ONLY AS SAFE AS THE OPERATOR!

Hazard control and accident prevention are dependent upon the awareness, concern, prudence, and proper training of the personnel involved in the operation, transport, maintenance, and storage of the equipment.

This manual covers the operating instructions
and illustrated parts list for:

GC-STT-52 with a serial number of 9510001 to 9519999

GC-STT-61 with a serial number of 9520001 to 9529999

GC-STT-72 with a serial number of 9530001 to 9539999

1.1 INTRODUCTION

This manual has been prepared to provide the information you need to correctly assemble, operate, and maintain this grass catcher. Read it carefully and keep it for future reference.

The replacement of any part on this product by other than the manufacturer's authorized replacement part may adversely affect the performance, durability or safety of this product.

USE OF OTHER THAN ORIGINAL SCAG REPLACEMENT PARTS WILL VOID THE WARRANTY.

If additional information or service is needed that is not outlined in this manual, please contact your Scag Power Equipment dealer. Scag dealers are trained in the latest service methods and carry a full line of Scag replacement parts.

When ordering parts, always provide the complete model and serial number of your catcher.

All information provided in this manual is based upon information available at the time of printing. Scag Power Equipment reserves the right to make changes at any time without notice or obligation.

1.2 DIRECTION REFERENCE

The "Right" and "Left", "Front" and "Rear" of the machine are referenced from the normal operating position.

2.1 SAFETY AND OPERATING INSTRUCTIONS

-NOTE-

To avoid personal injury, it is imperative that all safety instructions be observed.

1. **Read this operator's manual and the operator's manual that is supplied with the machine this attachment is used on.**

A replacement manual is available from your authorized Scag Service Dealer or by contacting: Scag Power Equipment, Service Department at P.O. Box 152, Mayville, WI 53050. You may also contact us through our website at www.scag.com. Please indicate the complete model and serial number of your Scag product when ordering a replacement manual.



2. Before removing the grass bags, disengage the mower, stop the engine and wait for all movement to stop.
3. **ALWAYS** turn the engine **OFF**, remove the key and wait for all movement to stop before servicing or cleaning the mower or the grass catcher.
4. Do not modify or alter any component of the grass catcher attachment or mower.
5. Do not allow any passengers to ride on the grass catcher attachment or on the mower.

3.1 ASSEMBLY INSTRUCTIONS FOR 52" CUTTER DECKS

-NOTE-

Use the illustrated parts list as a part number reference when following the assembly instructions.

1. Remove all packaging materials. Lay out the mounting hardware and the catcher assembly parts for easy access. Prepare the work area making sure that it is a clean, safe environment.
2. Remove the discharge chute from the cutter deck. See Figure 3-1.

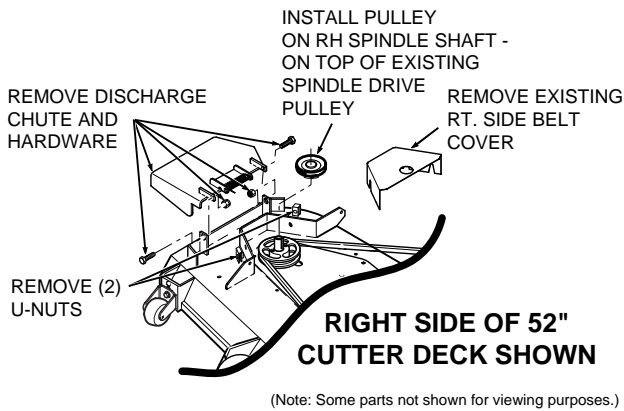

FIGURE 3-1

-NOTE-

Do not discard the discharge chute or mounting hardware. The discharge chute **MUST** be reinstalled anytime the grass catcher has been removed from the machine.

3. When installing this grass catcher on a machine with a serial number below 8619999, you will need to remove the discharge baffle from the bottom of the cutter deck. See Figure 3-2. Replace the discharge baffle with the new baffle provided with this grass catcher. Secure using the following hardware:

- (1) 04001-12 Hex Head Bolt 5/16-18 x 1-3/4"
- (1) 04001-09 Hex Head Bolt 5/16-18 x 1"
- (3) 04040-15 Flatwasher
- (3) 04021-10 Nut, Elastic Stop 5/16-18

When installing this grass catcher on an Advantage deck, install the front baffle to the cutter deck. See Figure 3-2. Secure using the following hardware:

- (2) 04017-05 Bolt, Hex Head 1/4-20 x 3/4"
- (2) 04019-02 Nut, Serrated Flange 1/4-20
- (2) 04003-23 Bolt, Carriage 3/8-16 x 1"
- (2) 04041-07 Flatwasher
- (2) 04021-09 Nut, Elastic Stop 3/8-16

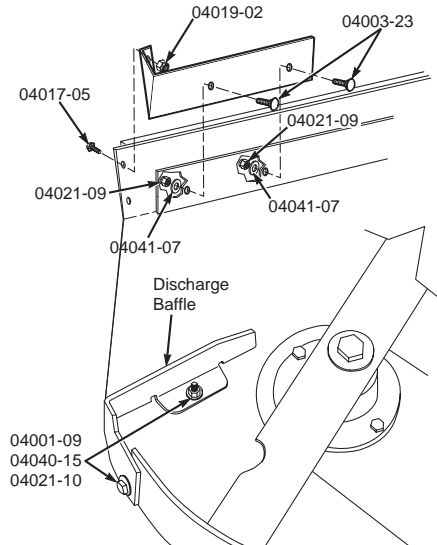

FIGURE 3-2

4. Remove the right side belt cover to gain access to the spindle assembly. Remove the u-nuts from the front and rear of the cutter deck bracket. See Figure 3-1.
5. Install the grass catcher pulley onto the spindle assembly. Apply loctite to both pulley setscrews and tighten. See Figure 3-1.

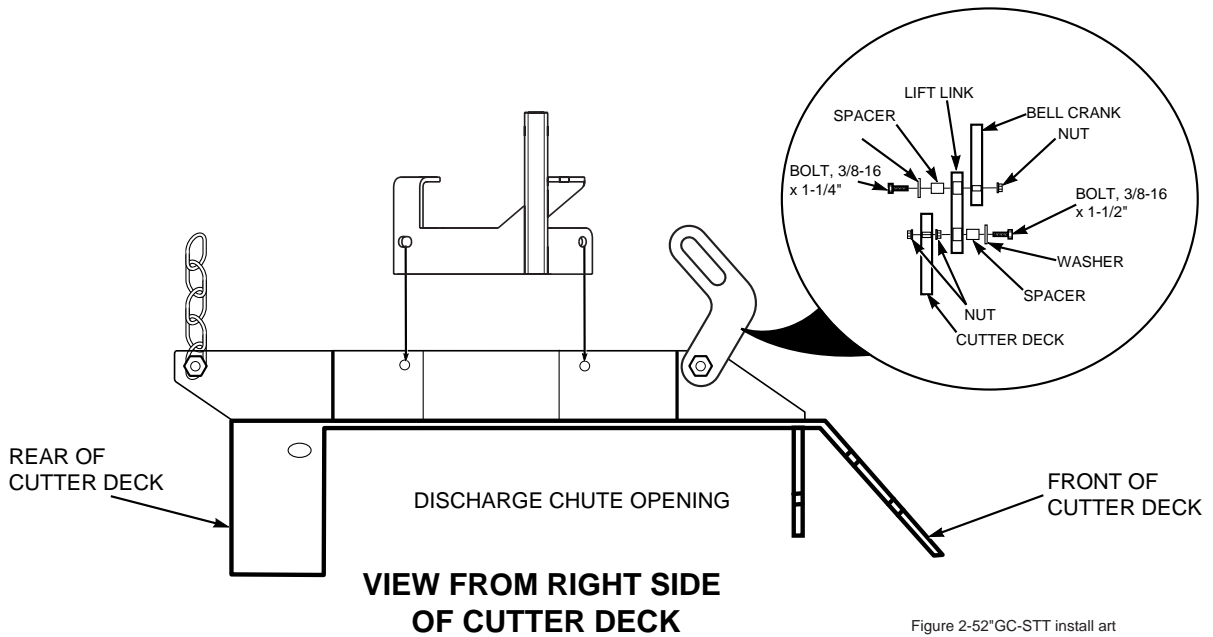

FIGURE 3-3

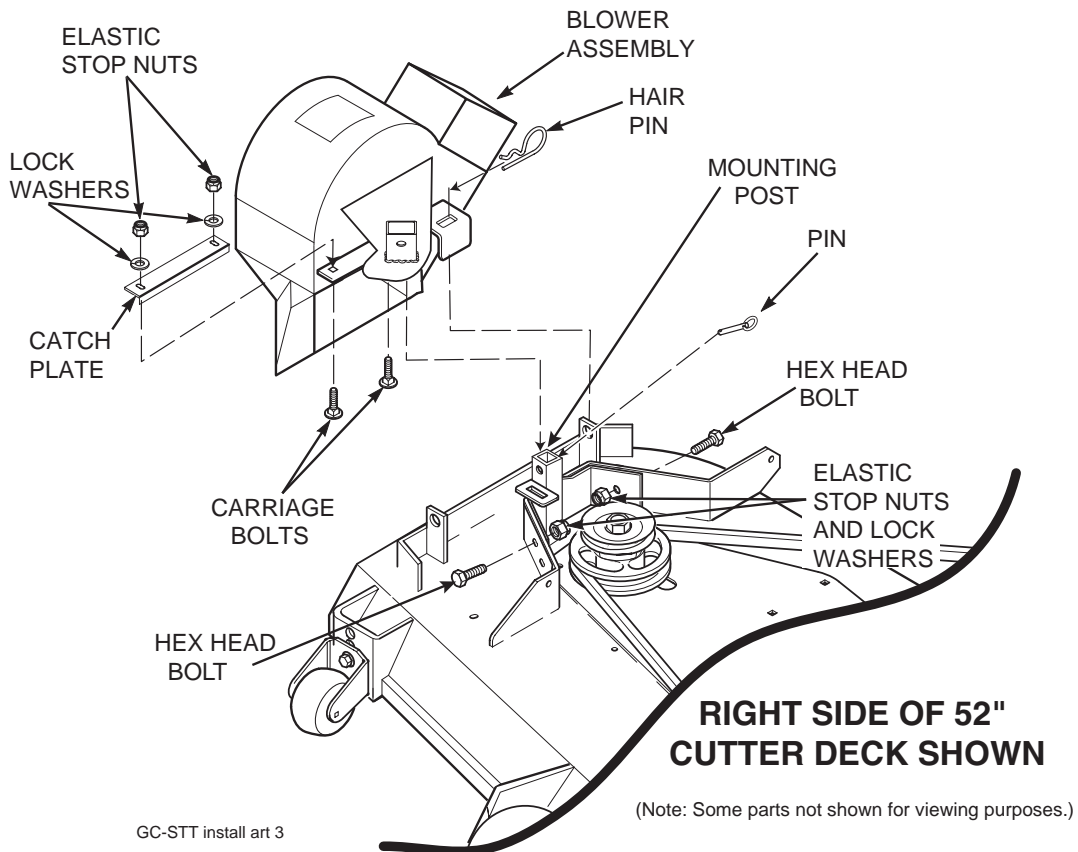
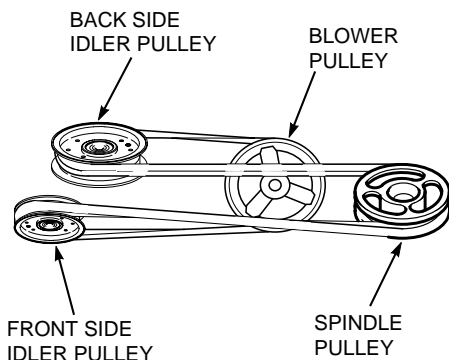

FIGURE 3-4

6. Install the blower mounting bracket to the deck using 1/2-13 x 1-1/2" hex head bolts (p/n 04001-71), 1/2" spring lockwashers (p/n 04030-06), and 1/2-13 elastic stop nuts (p/n 04021-07). See Figure 3-3, Page 3. Do not fully tighten the hardware at this time.
7. Block the right front side on the cutter deck and remove the hang chain. Install the deck lift link. Secure using hex head bolts (p/n 04001-32, 04001-20), flatwashers (p/n 04041-07), spacers (p/n 43212), and serrated flange nuts (p/n 04019-04). See Figure 3-3.
8. Install the new belt cover from the cutter deck to the blower mounting bracket and secure with one of the original belt cover plastic wing nuts.
9. Install the catch plate (p/n 423297) to the blower assembly using 3/8-16 x 1-1/4" carriage bolts (p/n 04003-11) facing upward. Secure with 3/8" spring lockwashers (p/n 04030-04) and 3/8-16 elastic stop nuts (p/n 04021-09). Do not fully tighten the hardware at this time.
10. Install the blower assembly to the mounting bracket and secure with the mounting pin. See Figure 3-4, Page 3.
11. Align the blower assembly with the discharge opening of the cutter deck. Tighten the hardware for the mounting bracket. Then tighten the hardware for the catch plate.
12. Install the belt to the spindle pulley. When replacing the belt, see figure below.



13. Install the plastic belt cover and secure with the plastic wing nuts. See Page 18 of the Illustrated Parts List for proper installation.
14. Install the hopper mounting brackets (p/n 451512) to the outside of the frame on the rear of the machine using 3/8-16 x 1" hex head bolts (p/n 04001-19) and 3/8-16 elastic stop nuts (p/n 04021-09). See Figure 5-6, Page 13.
15. Install the hopper hood assembly onto the catcher frame assembly and secure with 3/8-16 x 2-1/4" hex head bolts (p/n 04001-46) and 3/8-16 elastic stop nuts (p/n 04021-09) in the mounting holes. See Figure 5-6, Page 13.
16. Install the catcher support bracket onto the rear of the machine and secure with 5/16-18 x 1" carriage bolts (p/n 04003-04) and 5/16-18 serrated flange nuts (p/n 04019-03) See Figure 3-5.

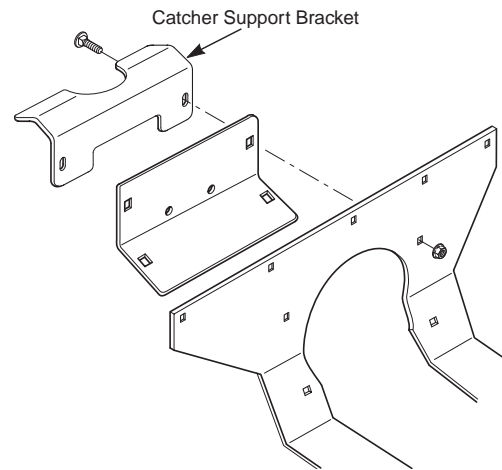

FIGURE 3-5

17. Install the heat shield to the hopper hood assembly and catcher frame assembly. Secure using the hardware specified in Figure 5-6, Page 13.
18. Install adapter (p/n 461419) to the blower assembly and secure with the strap.

19. Install the hose from the blower assembly to the hopper hood. Secure using the 8-1/2" clamps.

-NOTE-

When installing this catcher on machines equipped with an air cooled engine the discharge hose should be shortened to 56" in length.

20. Install the bag assemblies.
21. Install the weight support bar to the front of the machine by resting it directly on top of the caster support arms and sliding it tight against the frame of the machine. Secure the weight bar to the machine using (2) bar clamps, (4) 3/8-16 x 1-1/2" bolts and (4) 3/8-16 elastic stop nuts. See Figure 3-6.
22. Install the weight assemblies to the weight support bar and secure them to the bar using the 1/2"x 6-1/4" pin and lanyard. See Figure 3-6.

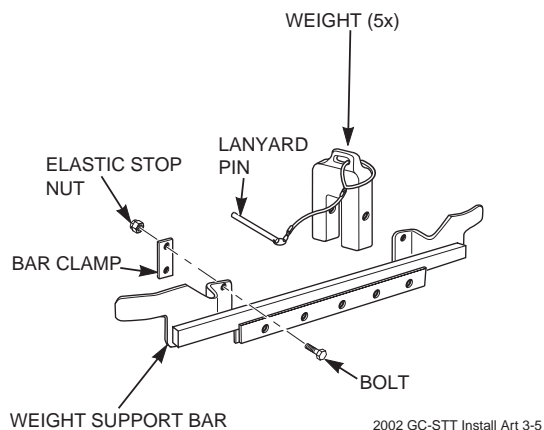

FIGURE 3-6

23. Operate and test.

4.1 ASSEMBLY INSTRUCTIONS FOR 61" CUTTER DECKS

-NOTE-

Use the illustrated parts list as a part number reference when following the assembly instructions.

1. Remove all packaging materials. Lay out the mounting hardware and the catcher assembly parts for easy access. Prepare the work area making sure that it is a clean, safe environment.
2. Remove the discharge chute from the cutter deck. See Figure 4-1.

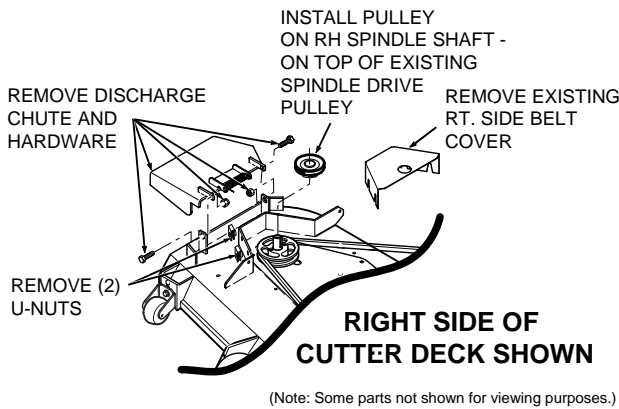

FIGURE 4-1

-NOTE-

Do not discard the discharge chute or mounting hardware. The discharge chute **MUST** be reinstalled anytime the grass catcher has been removed from the machine.

3. When installing this grass catcher on a machine with a serial number below 8619999, you will need to remove the discharge baffle from the bottom of the cutter deck. See Figure 4-2. Replace the discharge baffle with the new baffle provided with this grass catcher. Secure using the following hardware:

- (1) 04001-12 Hex Head Bolt 5/16-18 x 1-3/4"
- (1) 04001-09 Hex Head Bolt 5/16-18 x 1"
- (3) 04040-15 Flatwasher
- (3) 04021-10 Nut, Elastic Stop 5/16-18

When installing this grass catcher on an Advantage deck, install the front baffle to the cutter deck. See Figure 4-2. Secure using the following hardware:

- (2) 04017-05 Bolt, Hex Head 1/4-20 x 3/4"
- (2) 04019-02 Nut, Serrated Flange 1/4-20
- (2) 04003-23 Bolt, Carriage 3/8-16 x 1"
- (2) 04041-07 Flatwasher
- (2) 04021-09 Nut, Elastic Stop 3/8-16

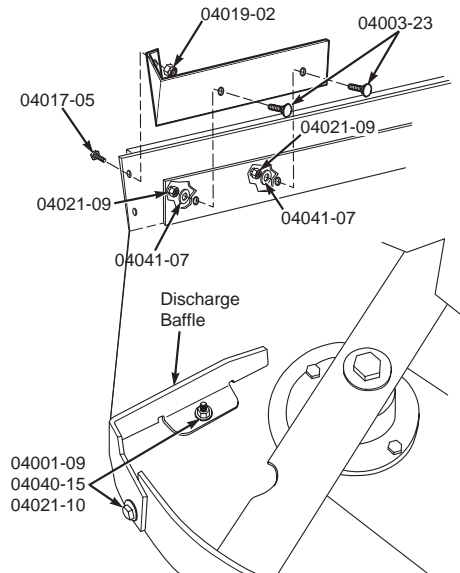

FIGURE 4-2

4. Remove the right side belt cover to gain access to the spindle assembly. Remove the two front u-nuts from the cutter deck bracket. See Figure 4-1.
5. Install the grass catcher pulley onto the spindle assembly. Apply loctite to both pulley setscrews and tighten. See Figure 4-1.

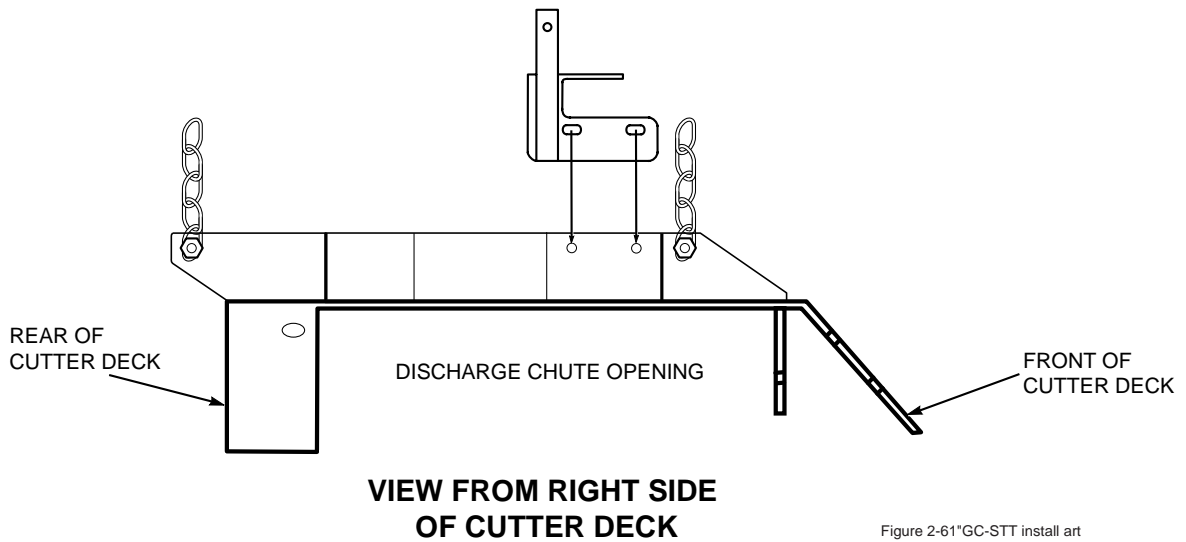

FIGURE 4-3

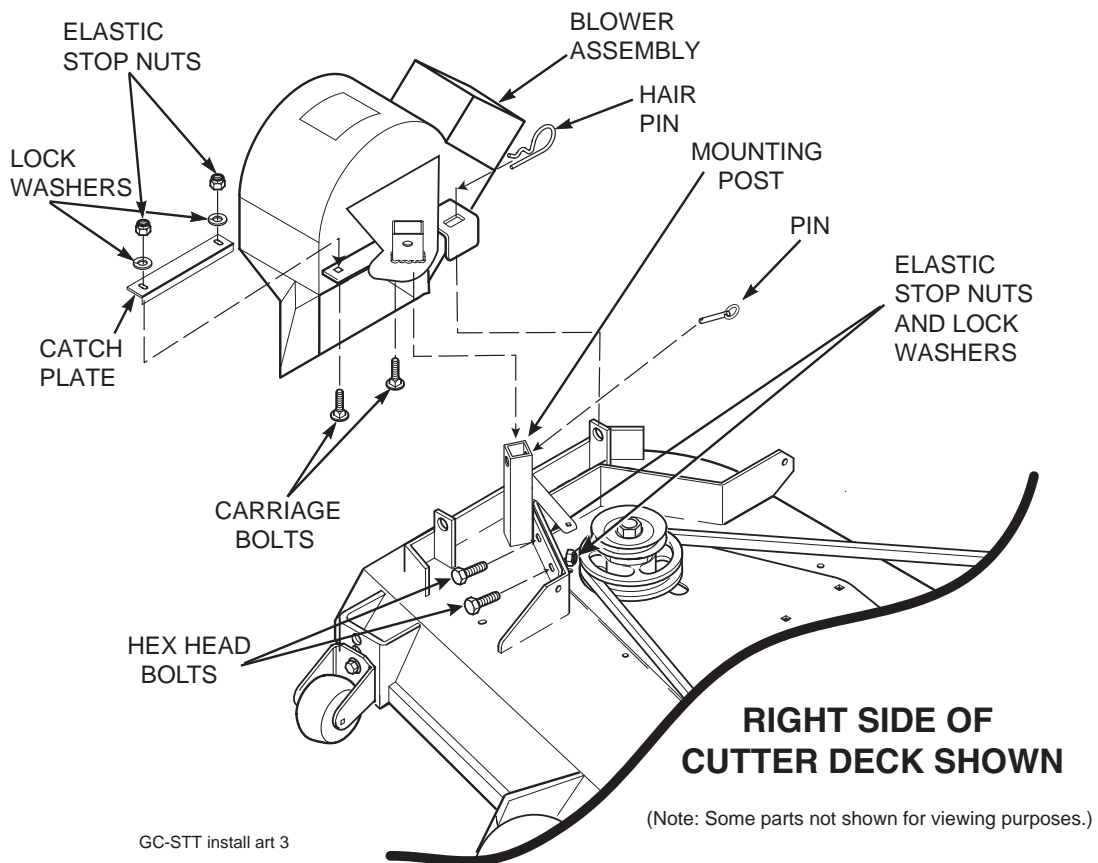
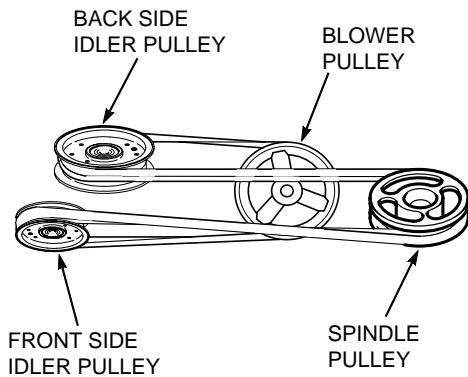

FIGURE 4-4

6. Install the blower mounting bracket to the deck using 1/2-13 x 1-1/2" hex head bolts (p/n 04001-71), 1/2" spring lockwashers (p/n 04030-06), and 1/2-13 elastic stop nuts (p/n 04021-07). See Figure 4-3, Page 7. Do not fully tighten the hardware at this time.
7. Install the catch plate (p/n 423297) to the blower assembly using 3/8-16 x 1-1/4" carriage bolts (p/n 04003-11) facing upward. See Figure 4-4, Page 7. Secure with 3/8" spring lockwashers (p/n 04030-04) and 3/8-16 elastic stop nuts (p/n 04021-09). Do not fully tighten the hardware.
8. Install the blower assembly to the mounting bracket and secure with the mounting pin. See Figure 4-4, Page 7.
9. Align the blower assembly with the discharge opening of the cutter deck. Tighten the hardware for the mounting bracket. Then tighten the hardware for the catch plate.
10. Install the belt to the spindle pulley. When replacing the belt, see figure below.



11. Install the new belt covers and secure with the plastic wing nuts. See Page 18 of the Illustrated Parts List for proper installation.
12. Install the hopper mounting brackets (p/n 451512) to the outside of the frame on the rear of the machine using 3/8-16 x 1" hex head bolts (p/n 04001-19) and 3/8-16 elastic stop nuts (p/n 04021-09). See Figure 5-6, Page 13.

13. Install the hopper hood assembly onto the catcher frame assembly and secure with 3/8-16 x 2-1/4" hex head bolts (p/n 04001-46) and 3/8-16 elastic stop nuts (p/n 04021-09). See Figure 5-6, Page 13.
14. Install the catcher support bracket onto the rear of the machine and secure with 5/16-18 x 1" carriage bolts (p/n 04003-04) and 5/16-18 serrated flange nuts (p/n 04019-03). See Figure 4-5.

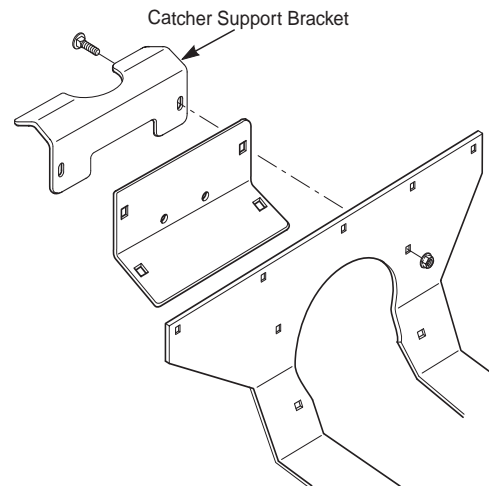

FIGURE 4-5

15. Install the heat shield to the hopper hood assembly and catcher frame assembly. Secure using the hardware specified in Figure 5-6, Page 13.
16. Install the catcher frame assembly onto the rear of the machine and secure with the quick pins (p/n 04066-03) See Figure 5-6, Page 13.
17. Install adapter (p/n 461419) to the blower assembly and secure with the strap.

18. Install the hose from the blower assembly to the hopper hood. Secure using the 8-1/2" clamps.

-NOTE-

When installing this catcher on machines equipped with an air cooled engine the discharge hose should be shortened to 56" in length.

19. Install the bag assemblies.
20. Install the weight support bar to the front of the machine by resting it directly on top of the caster support arms and sliding it tight against the frame of the machine. Secure the weight bar to the machine using (2) bar clamps, (4) 3/8-16 x 1-1/2" bolts and (4) 3/8-16 elastic stop nuts. See Figure 4-6.
21. Install the weight assemblies to the weight support bar and secure them to the bar using the 1/2"x 6-1/4" pin and lanyard. See Figure 4-6.

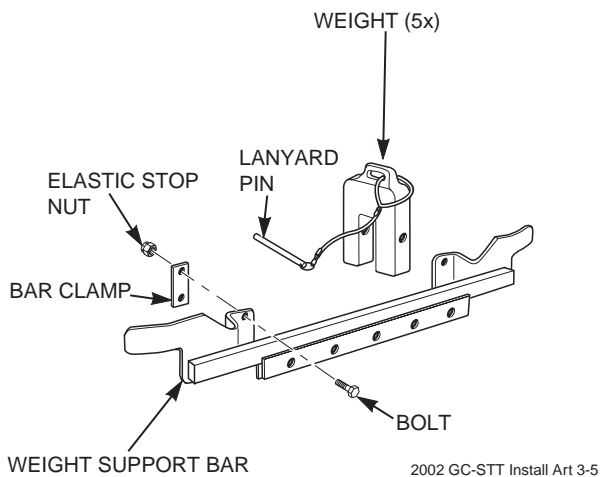

FIGURE 4-6

22. Operate and test.

5.1 ASSEMBLY INSTRUCTIONS FOR 72" CUTTER DECKS

-NOTE-

Use the illustrated parts list as a part number reference when following the assembly instructions.

1. Remove all packaging materials. Lay out the mounting hardware and the catcher assembly parts for easy access. Prepare the work area making sure that it is a clean, safe environment.
2. Remove the discharge chute from the cutter deck. See Figure 5-1.

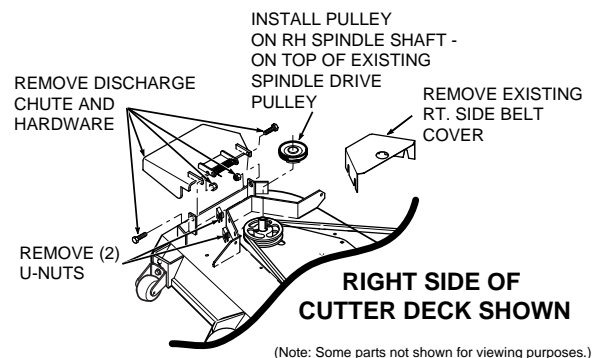

FIGURE 5-1

-NOTE-

Do not discard the discharge chute or mounting hardware. The discharge chute **MUST** be reinstalled anytime the grass catcher has been removed from the machine.

! WARNING

DO NOT OPERATE WITHOUT DISCHARGE CHUTE, MULCHING KIT, OR ENTIRE GRASS CATCHER INSTALLED

- When installing this grass catcher on a machine with a serial number below 8619999, you will need to remove the discharge baffle from the bottom of the cutter deck. See Figure 5-2. Replace the discharge baffle with the new baffle provided with this grass catcher. Secure using the following hardware:

- (1) 04001-12 Hex Head Bolt 5/16-18 x 1-3/4"
- (1) 04001-09 Hex Head Bolt 5/16-18 x 1"
- (3) 04040-15 Flatwasher
- (3) 04021-10 Nut, Elastic Stop 5/16-18

When installing this grass catcher on an Advantage deck, install the front baffle to the cutter deck. See Figure 5-2. Secure using the following hardware:

- (2) 04017-05 Bolt, Hex Head 1/4-20 x 3/4"
- (2) 04019-02 Nut, Serrated Flange 1/4-20
- (2) 04003-23 Bolt, Carriage 3/8-16 x 1"
- (2) 04041-07 Flatwasher
- (2) 04021-09 Nut, Elastic Stop 3/8-16

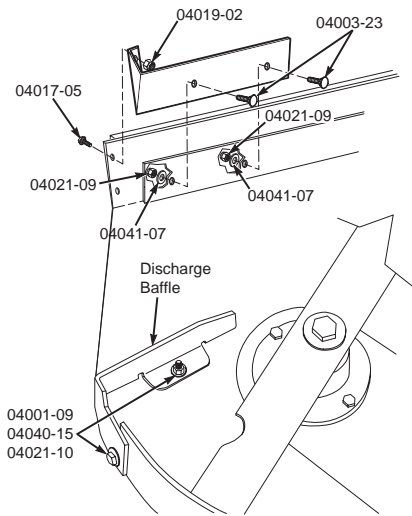
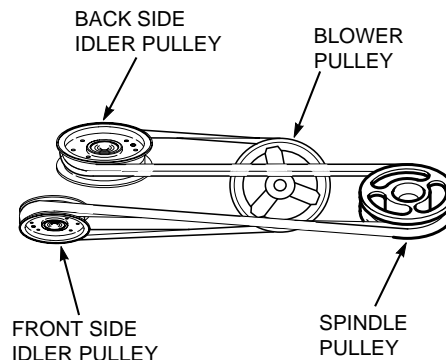

FIGURE 5-2

- Remove the right side belt cover to gain access to the spindle assembly. Remove the two front u-nuts from the cutter deck bracket. See Figure 5-1, Page 9.
- Install the grass catcher pulley onto the spindle assembly. Apply loctite to both pulley setscrews and tighten. See Figure 5-1.

- Install the blower mounting bracket to the deck using 1/2-13 x 1-1/2" hex head bolts (p/n 04001-71), 1/2" spring lockwashers (p/n 04030-06), and 1/2-13 elastic stop nuts (p/n 04021-07). See Figure 5-3, Page 11. Do not fully tighten the hardware at this time.
- Install the new belt cover from the cutter deck to the blower mounting bracket and secure with one of the original belt cover plastic wing nuts.
- Install the catch plate (p/n 423297) to the blower assembly using 3/8-16 x 1-1/4" carriage bolts (p/n 04003-11) facing upward. See Figure 5-3, Page 11. Secure with 3/8" spring lockwashers (p/n 04030-04) and 3/8-16 elastic stop nuts (p/n 04021-09). Do not fully tighten the hardware at this time.
- Install the blower assembly to the mounting bracket and secure with the mounting pin and large hair pin. See Figure 5-3, Page 11.
- Align the blower assembly with the discharge opening of the cutter deck. Tighten the hardware for the mounting bracket. Then tighten the hardware for the catch plate.
- Install the belt to the spindle pulley. When replacing the belt, see figure below.



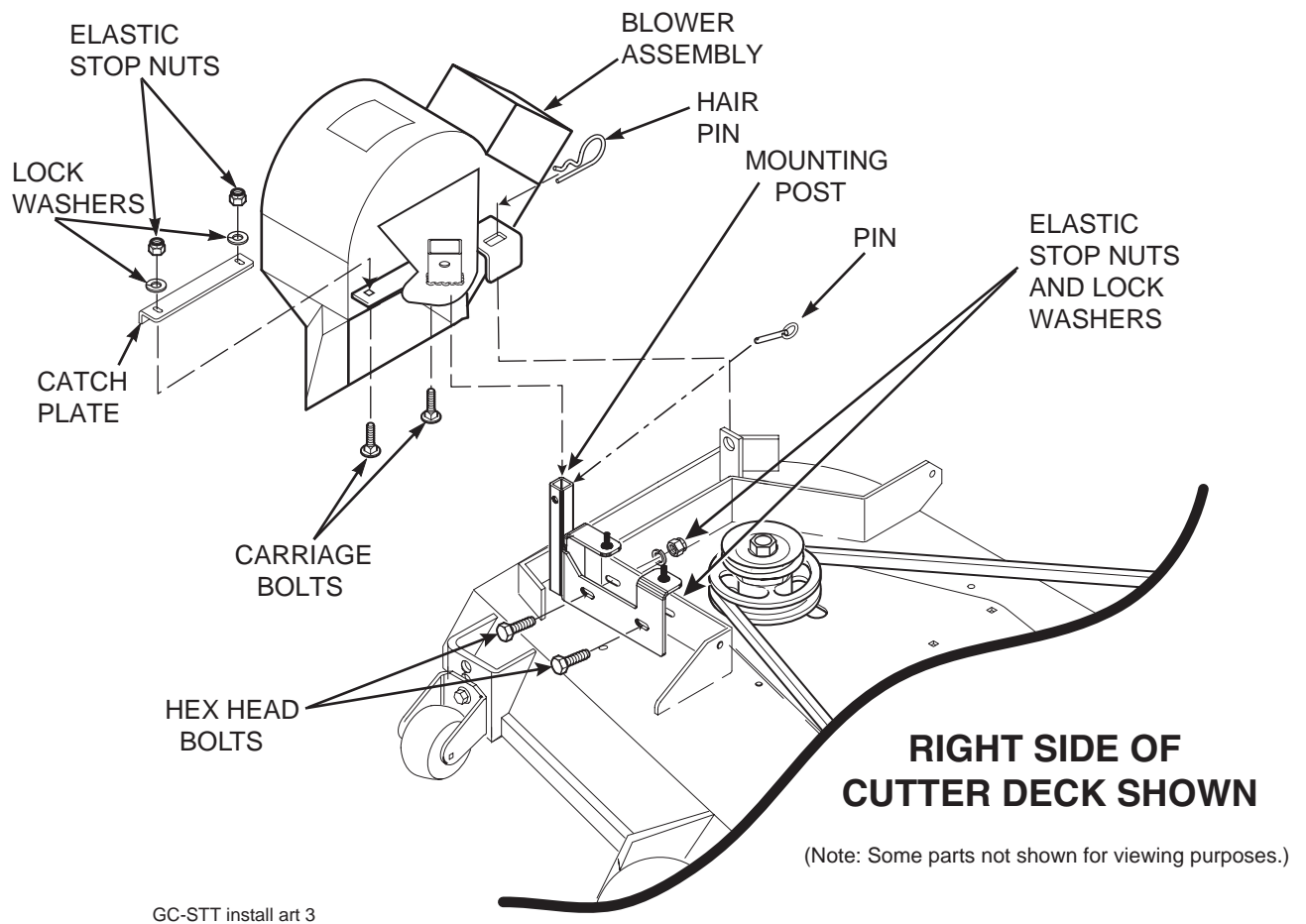

FIGURE 5-3

12. Install the plastic belt cover and secure with the plastic wing nuts. See Page 18 of the Illustrated Parts List for proper installation.

13. Install the hopper mounting brackets (p/n 451512 & p/n 451595) to the outside of the frame on the rear of the machine using 3/8-16 x 1" hex head bolts (p/n 04001-19) and 3/8-16 elastic stop nuts (p/n 04021-09). See Figure 5-6, Page 13.

14. Install the catcher support bracket onto the rear of the machine and secure with 5/16-18 x 1" carriage bolts (p/n 04003-04) and 5/16-18 serrated flange nuts (p/n 04019-03) See Figure 5-4.

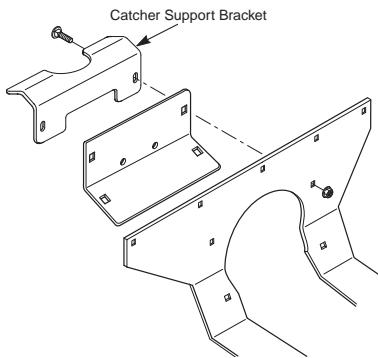

FIGURE 5-4

15. Install the heat shield to the hopper hood assembly and catcher frame assembly. Secure using the hardware specified in Figure 5-6, Page 13.

16. Install the catcher frame assembly onto the rear of the machine and secure with the quick pins (p/n 04066-03) See Figure 5-6, Page 13.

17. Install adapter (p/n 461419) to the blower assembly and secure with the strap.

18. Install the hose from the blower assembly to the hopper hood. Secure using the 8-1/2" clamps.

-NOTE-

When installing this catcher on machines equipped with an air cooled engine the discharge hose should be shortened to 56" in length.

19. Install the bag assemblies.

20. Install the weight support bar to the front of the machine by resting it directly on top of the caster support arms and sliding it tight against the frame of the machine. Secure the weight bar to the machine using (2) bar clamps, (4) 3/8-16 x 1-1/2" bolts and (4) 3/8-16 elastic stop nuts. See Figure 5-5

21. Install the weight assemblies to the weight support bar and secure them to the bar using the 1/2" x 6-1/4" pin and lanyard. See Figure 5-5.

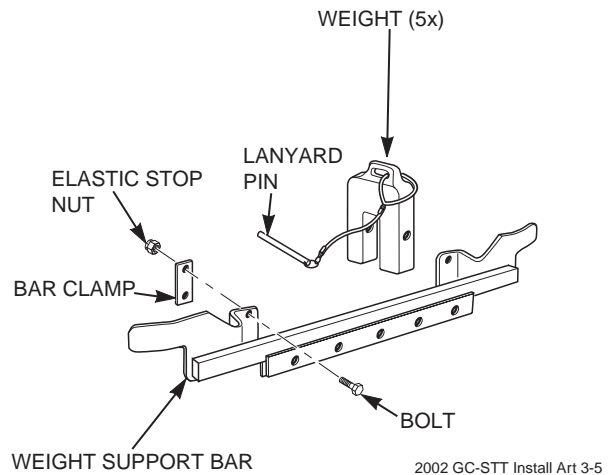
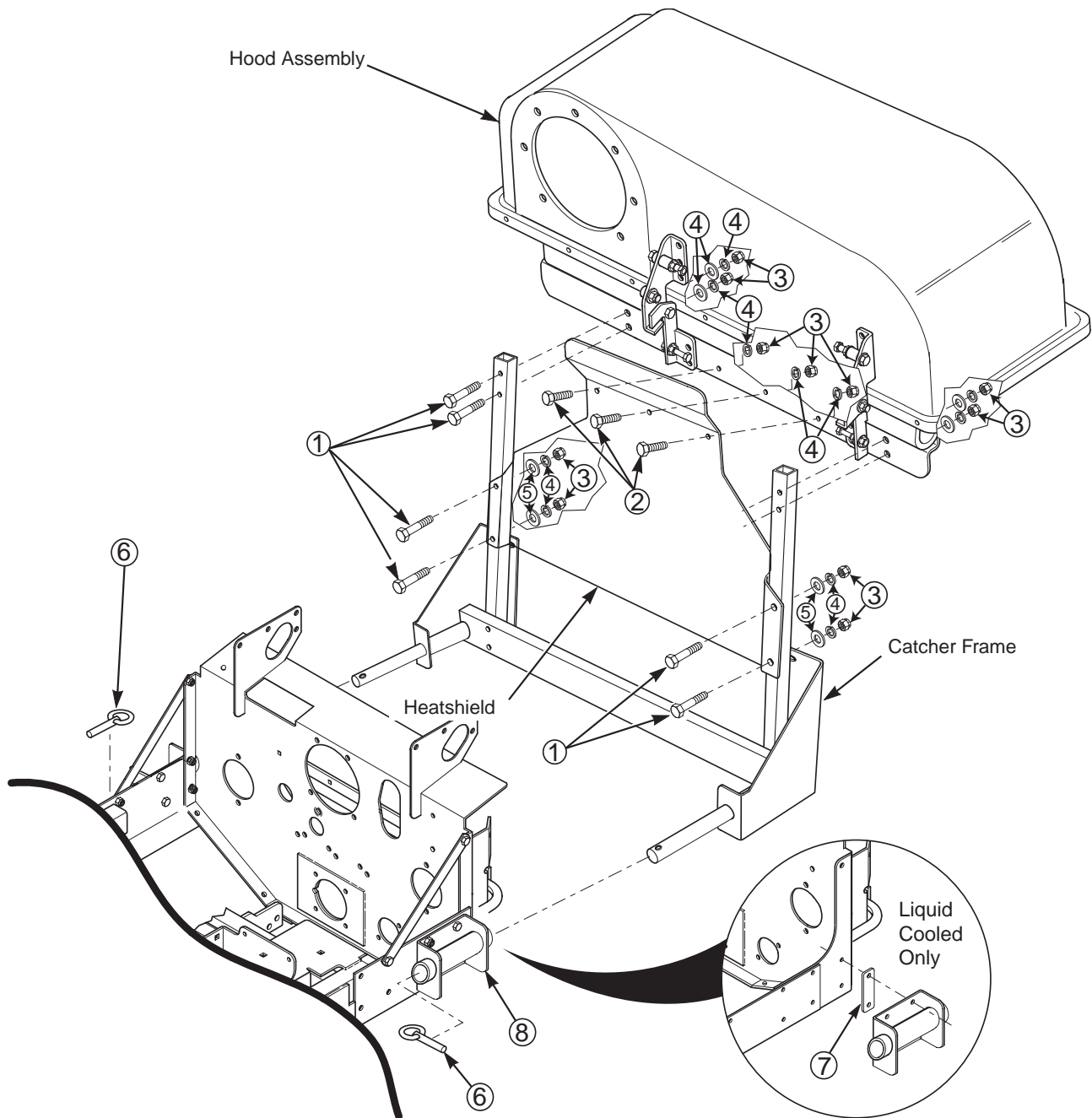

FIGURE 5-5

22. Operate and test.



Item #	Part #	Description
1	04001-46	Bolt, Hex Head 3/8-16 x 2-1/4"
2	04001-19	Bolt, Hex Head 3/8-16 x 1"
3	04021-09	Nut, Elastic Stop 3/8-16
4	04030-04	Lockwasher, 3/8 Spring
5	04041-07	Flatwasher, 3/8-.391 x .938 x .105
6	04066-03	Quick Pin
7	423670	Spacer, Hitch
8	451512	Hitch Bracket Weldment

FIGURE 5-6

6.1 GRASS CATCHER REMOVAL INSTRUCTIONS

1. Prepare the work area making sure that it is a clean, safe environment.
2. Remove the bag assemblies from the grass catcher.
3. Remove the rubber strap holding the adapter to the blower assembly. See Figure 6-1.
4. Remove the belt from the spindle pulley.
4. Remove the pin holding the blower assembly to the mounting bracket on the cutter deck and remove the blower assembly. See Figure 6-1.

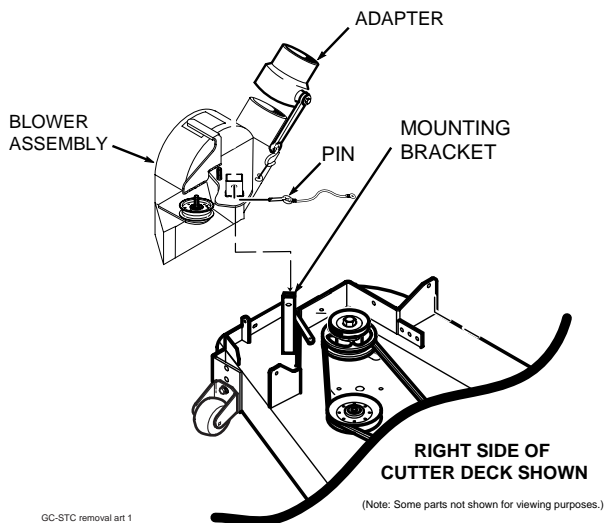

Figure 6-1

5. Remove the two (2) pins holding the hood assembly to the mounting brackets on the rear of the machine. See Figure 6-2.

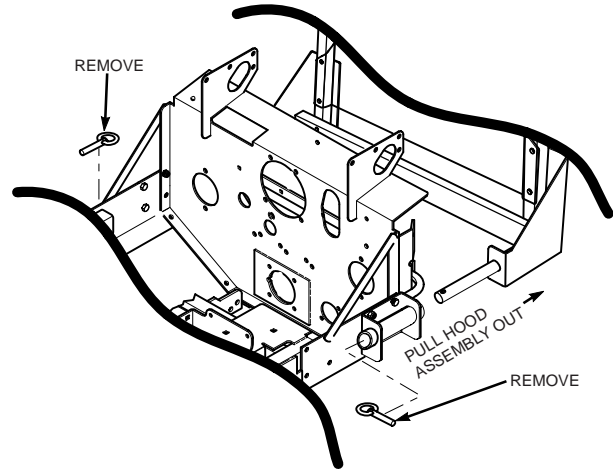

Figure 6-2

6. Remove the hood assembly.
7. Remove the front weights by removing the quick pins.
8. Re-install the side discharge chute to the opening on the cutter deck. Replace the two (2) outside mounting bolts on the discharge chute with the clevis pins (p/n 04064-15) and rue cotter pins (p/n 04069-03). See Figure 6-3.

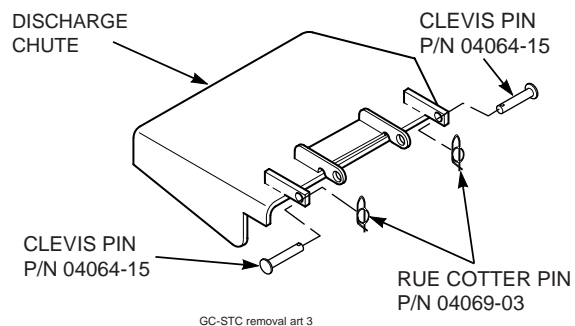

Figure 6-3

⚠ WARNING

DO NOT OPERATE WITHOUT DISCHARGE CHUTE, MULCHING KIT, OR ENTIRE GRASS CATCHER INSTALLED 482165

NOTES

GC-STT BLOWER HOUSING ASSEMBLY

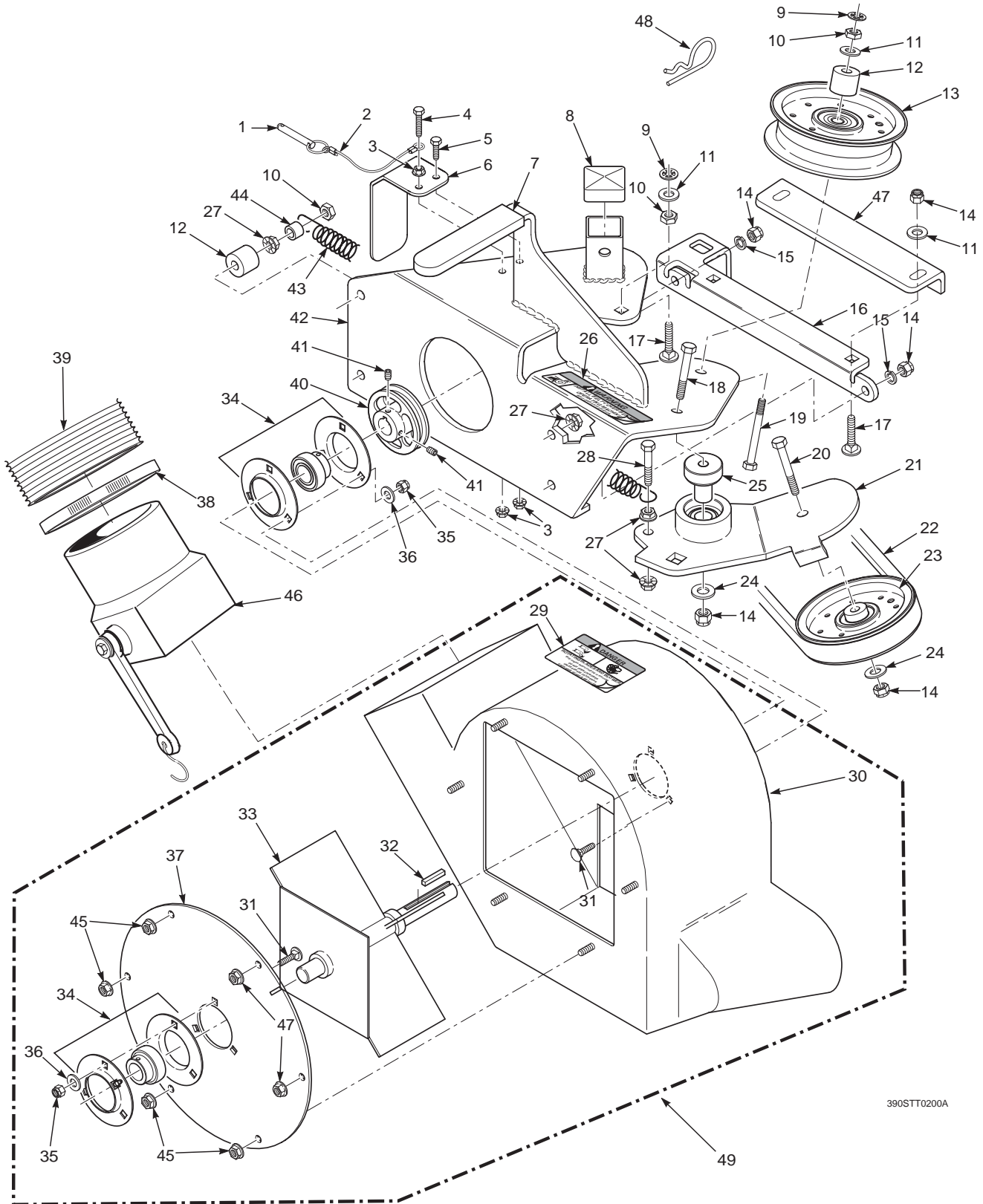

390STT0200A

GC-STT BLOWER HOUSING ASSEMBLY

Ref. No.	Part Number	Description	Ref. No.	Part Number	Description
1	04067-07	Pin, Ring 2-1/4" Long	25	43504	Pivot, Idler - 52"
2	481547	Lanyard, Deck Height Pin		43575	Pivot, Idler - 61"
3	04019-02	Nut, Serr. Flange 1/4-20	26	481039	Decal, Belt Cover
4	04001-59	Bolt, Hex Head 1/4-20 x 1-1/4"	27	04019-04	Nut, Serr. Flange 3/8-16
5	04001-01	Bolt, Hex Head 1/4-20 x 3/4"	28	04001-136	Bolt, Hex Head 3/8-16 x 1-1/2 Gr. 8
6	423298	Belt Cover, Rear	29	482293	Decal, Danger
7	481428	Grip, Blower Lever	30	461681	Blower Housing Assembly
8	482300	Cap, Square	31	04003-12	Bolt, Carr. 5/16-18 x 3/4" Gr. 5
9	04024-02	Nut, Push On 3/8 Thread	32	04063-06	Key, 1/4 x 1/4 x 1-1/2"
10	04021-05	Lock Nut, 3/8-16	33	451420	Fan Weldment
11	04041-07	Flatwasher, 3/8-.391 x .938 x .105	34	48915	Bearing Assembly
12	43277	Spacer	35	04021-10	Nut, Elastic Stop 5/16-18
13	481048	Pulley, Idler 3" Dia. - 52" Cutter Deck	36	04040-04	Flatwasher, 5/16-.344 x .688 x .065
	482299	Pulley, Idler 4" Dia. - 61" Cutter Deck	37	421319	Cover, Blower Housing
14	04021-09	Nut, Elastic Stop 3/8-16	38	48136-02	Clamp, 8-5/8" Max Dia.
15	04030-04	Lockwasher, 3/8-16	39	48135-13	Hose, 8.00" Dia. x 56.00" Long
16	423933	Plate, Catch Mounting		48135-15	Hose, 8.00" Dia. x 68.00" Long - 72A
	423952	Plate, Catch Mounting - 72"	40	482298	Pulley, 4-3/4" O.D. - 1" Bore
17	04003-05	Bolt, Carr. 3/8-16 x 1-1/2"	41	04012-04	Set Screw, 5/16-18 x 3/8"
18	04001-54	Bolt, Hex Head 3/8-16 x 3" - 52"	42	461683	Frame, Blower Mount - 52"
	04001-46	Bolt, Hex Head 3/8-16 x 2-1/4" - 61"		461684	Frame, Blower Mount - 61"
19	04001-81	Bolt, Hex Head 3/8-16 x 3-1/2"		451685	Frame, Blower Mount - 72"
20	04001-21	Bolt, Hex Head 3/8-16 x 1-3/4"	43	481522	Spring, Main Drive
21	461427	Idler Arm Assembly, GC-STT 52"	44	43212	Spacer
	461389	Idler Arm Assembly, GC-STT 61"	45	04019-03	Nut, Serr. Flange 5/16-18
22	482428	Belt, GC-STT 52"	46	461419	Adapter w/Strap\
	482379	Belt, GC-STT 61"	47	423297	Plate, Blower Catch
	482831	Belt, GC-STT 72"		423939	Plate, Blower Catch - 72"
23	482079	Pulley, 3" O.D., GC-STT 52"	48	04062-05	Hair Pin Cotter, .243 x 4"
	482062	Pulley, 4" O.D., GC-STT 61"	49	461680	Blower Housing Assembly, GC-STT
24	04043-04	Washer, 3/8 Hardened			

GC-STT BLOWER MOUNTING COMPONENTS

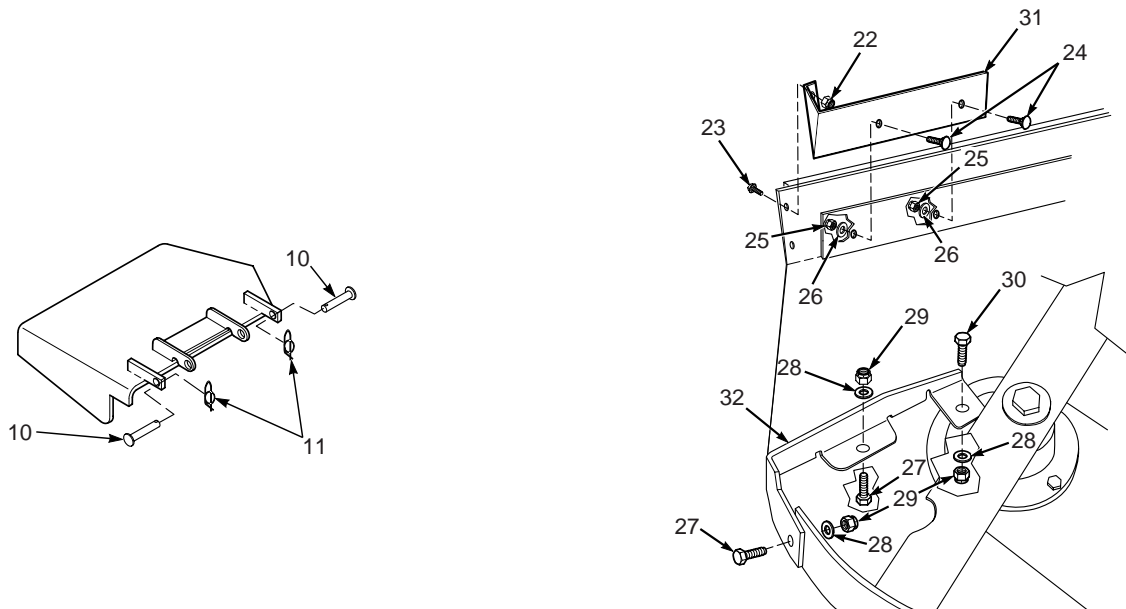

**UNDER SIDE OF
CUTTER DECK SHOWN**

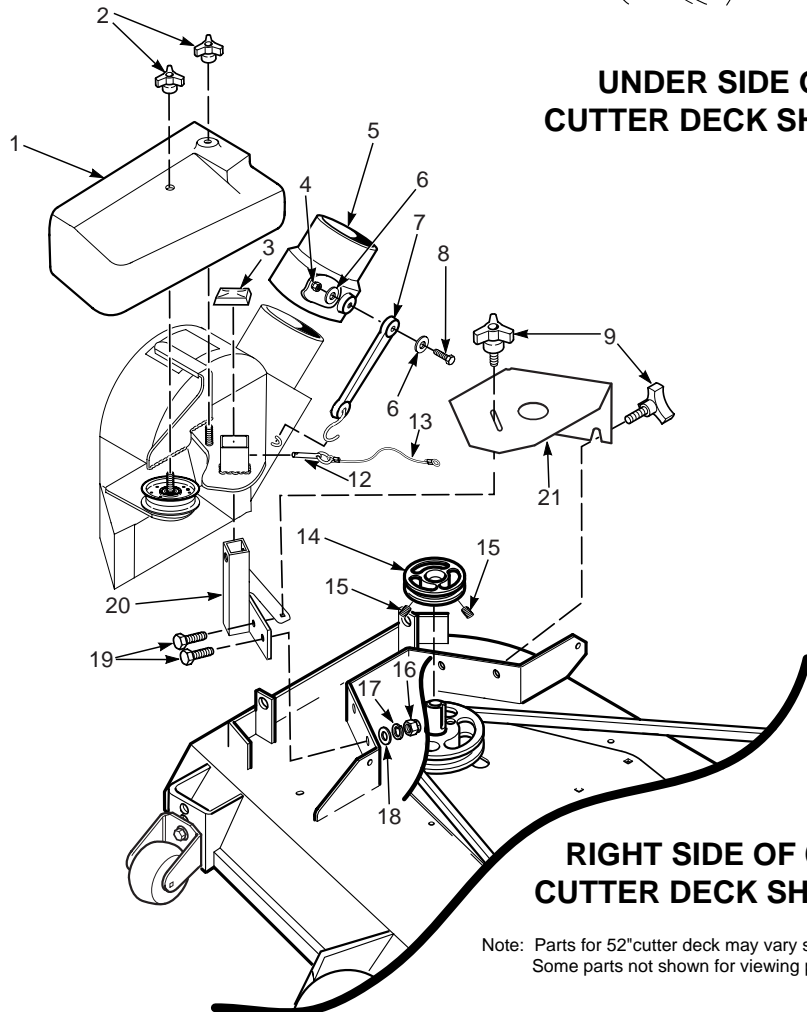

**RIGHT SIDE OF 61"
CUTTER DECK SHOWN**

Note: Parts for 52" cutter deck may vary slightly from illustration.
Some parts not shown for viewing purposes.

390STT0203

GC-STT BLOWER MOUNTING COMPONENTS

Ref. No.	Part Number	Description
1	482406	Belt Cover, GC-STT - 52"
	482378	Belt Cover, GC-STT - 61" & 72"
2	04029-04	Wingnut, Plastic 3/8 Small
3	482300	Cap, Square Vinyl
4	04021-08	Nut, Elastic Stop 1/4-20
5	461419	Adapter, Blower GC-STT
6	04040-14	Flatwasher, 1/4-.312 x .750 x .065
7	48137-04	Rubber Strap 7-3/4"
8	04001-59	Bolt, Hex Head 1/4-20 x 1-1/4"
9	481625-01	Knob W/Stud, 3/8-16 x 1-1/4"
10	04064-15	Clevis Pin, 5/16 x 1-1/2"
11	04069-03	Pin, Rue Cotter 5/16 Dia.
12	04067-07	Pin, Ring 1/2 x 2-1/4"
13	481547	Lanyard
14	482427	Pulley, 4-1/2" for 52" Deck
	482377	Pulley, 5-1/2" for 61" Deck
	482830	Pulley, 6-1/4" for 72" Deck
15	04012-04	Setscrew, 5/16-18 x 3/8"
16	04021-07	Nut, Elastic Stop 1/2-13
17	04030-06	Lockwasher, 1/2"
18	04040-07	Flatwasher, 1/2-.531 x 1.062 x .095
19	04001-71	Bolt, Hex Head 1/2-13 x 1-1/2" Grade 5
20	461418	Mounting Post Weldment, Blower - 52"
	451413	Mounting Post Weldment, Blower - 61"
	451657	Mounting Post Weldment, Blower - 72"
21	423427	Belt Cover, - 52"
	423446	Belt Cover, - 61"
	423940	Belt Cover, - 72"
22	04019-02	Nut, Serrated Flange 1/4-20
23	04017-05	Bolt, Hex Head 1/4-20 x 3/4"
24	04003-23	Bolt, Carriage 3/8-16 x 1"
25	04021-09	Nut, Elastic Stop 3/8-16
26	04041-07	Flatwasher, 3/8-.391 x .938 x .105
27	04001-09	Bolt, Hex Head 5/16-18 x 1"
28	04040-15	Flatwasher, 5/16-.375 x .875 x .083
29	04021-10	Nut, Elastic Stop 5/16-18
30	04001-12	Bolt, Hex Head 5/16-18 x 1-3/4"
31	423629	Baffle, 52"
	423448	Baffle, 61"
	423932	Baffle, 72"
32	423956	Baffle, 52" Deck
	423957	Baffle, 61" Deck
	423958	Baffle, 72" Deck

GC-STT BUCKET SUPPORT COMPONENTS

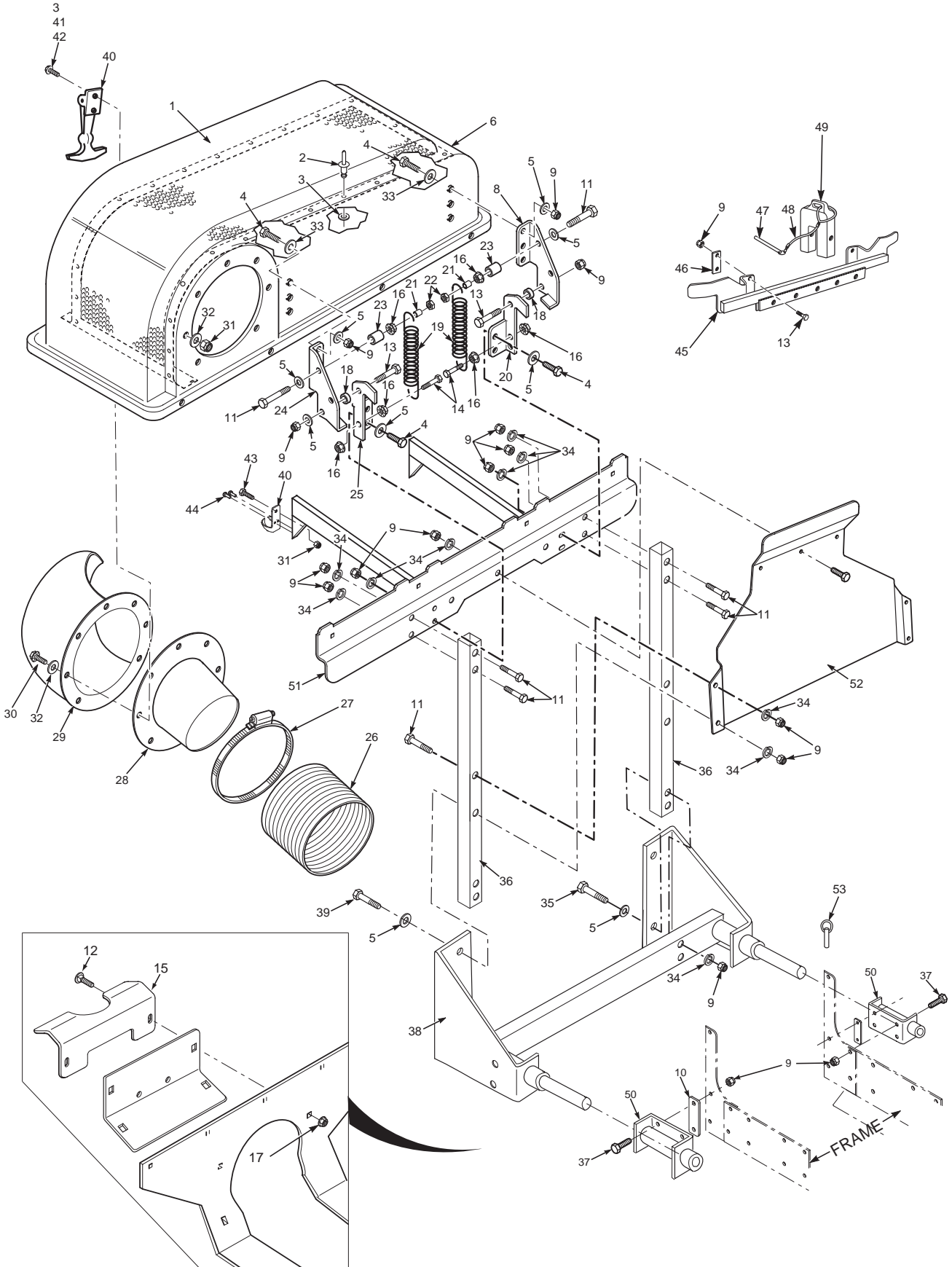

GC-STT BUCKET SUPPORT COMPONENTS

Ref. No.	Part Number	Description
1	423302	Screen, Catcher Hood
2	04090-02	Pop Rivet, 3/16 x .652
3	04041-19	Flatwasher, 3/16-.196 x .469 x .048
4	04001-32	Bolt, Hex Head 3/8-16 x 1-1/4"
5	04041-07	Flatwasher, 3/8-.391 x .938 x .105
6	461408	Hood Assembly, GC-STT (includes item 1 and items 2 & 4 on page 17)
7	04001-161	Bolt, Hex Head 3/8-16 x 2-3/4"
8	423258	Hinge, Upper LH
9	04021-09	Nut, Elastic Stop 3/8-16
10	423670	Spacer, Hitch
11	04001-46	Bolt, Hex Head 3/8-16 x 2-1/4"
12	04003-04	Bolt, Carriage 5/16-18 x 1.00
13	04001-20	Bolt, Hex Head 3/8-16 x 1-1/2"
14	04001-135	Bolt, Hex Head 3/8-16 x 1-3/4" Grade 8
15	423690	Support Bracket, Catcher
16	04019-04	Nut, Serrated Flange 3/8-16
17	04019-03	Nut, Hex Serrated Flange 5/16-18
18	43546	Bushing, Hopper Pivot
19	482304	Spring, Hood Hinge
20	423436	Hinge, Lower LH
21	43212	Spacer
22	04021-05	Locknut, 3/8-16
23	43277	Spacer
24	423259	Hinge, Upper RH
25	423261	Hinge, Lower RH
26	48135-14	Hose, 8" Dia. x 60.5"
27	48136-02	Clamp, 8-5/8" Max Dia.
28	482422	Tube, Filler GC-STT
29	482421	Elbow, GC-STT
30	04001-10	Bolt, Hex Head 5/16-18 x 1-1/4"
31	04021-10	Nut, Elastic Stop 5/16-18
32	04040-15	Flatwasher, 5/16-.375 x .875 x .083
33	04041-11	Flatwasher, 3/8-.406 x 1-1/2" x .179
34	04030-04	Lockwasher, 3/8 Spring
35	04001-51	Bolt, Hex Head 3/8-16 x 3-3/4"
36	423426	Tube, Upright
37	04001-19	Bolt, Hex Head 3/8-16 x 1"
38	451511	Frame Weldment
39	04001-31	Bolt, Hex Head 3/8-16 x 2-1/2"
40	482409	Latch
41	04010-25	Screw, #10-32 x 3/4"
42	04021-01	Nut, Elastic Stop #10-32
43	04001-08	Bolt, Hex Head 5/16-18 x 3/4"
44	04090-03	Rivet, 3/16 x .402 POP
45	451026	Support Weldment, Front Weights
46	422586	Clamp, Bar
47	04067-06	Pin, 1/2 x 6-1/4"
48	481737	Lanyard, Weight Pin
49	9009	Weight Assembly
50	451512	Hitch Bracket Weldment
51	451516	Support Weldment, Bag Frame
52	423435	Heat Shield
53	04066-03	Quick Pin

-NOTE-

Some of the hardware is common hardware and you may purchase it locally. Be sure that all bolts purchased locally are a grade 5.

GC-STT BAG SUPPORT BRACKET AND SEAL

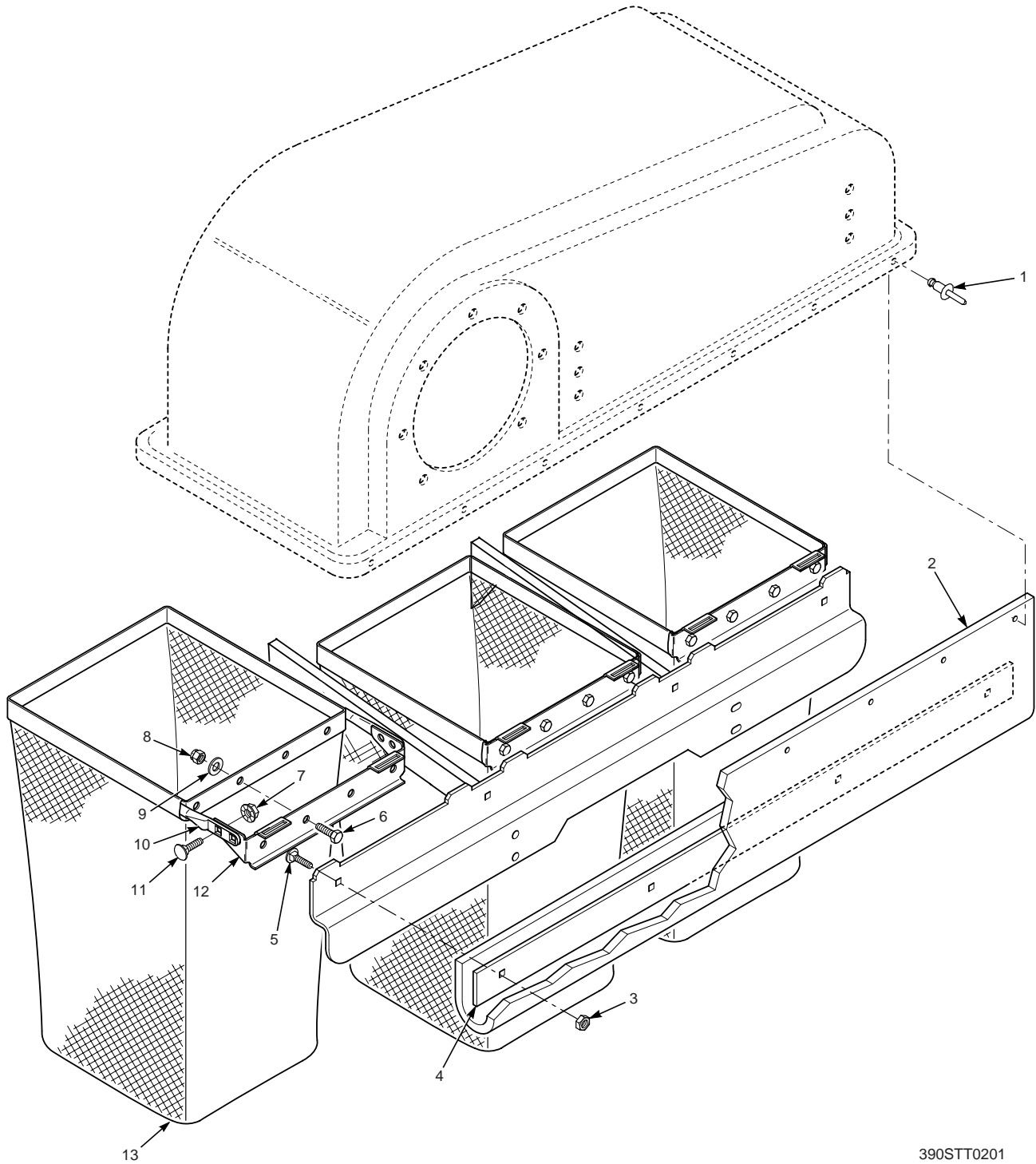

390STT0201

GC-STT BAG SUPPORT BRACKET AND SEAL

Ref. No.	Part Number	Description
1	04090-02	Pop Rivet, 3/16 x .652
2	482321	Seal, Hood
3	04021-02	Lock Nut, 1/4-20 Center Lock
4	423312	Retainer, Seal
5	04003-02	Bolt, Carr. 1/4-20 x 3/4"
6	04001-08	Bolt, Hex Head 5/16-18 x 3/4"
7	04019-03	Nut, Serrated Flange 5/16-18
8	04021-10	Nut, Elastic Stop 5/16-18
9	04040-15	Flatwasher, 5/16-.375 x .875 x .083
10	423197	Tube, Bag Support
11	04003-12	Bolt, Carr. 5/16-18 x 3/4"
12	423198	Mount, Bag Frame Tube
13	482569	Bag Assembly, GC-STT

-NOTE-

Some of the hardware is common hardware and you may purchase it locally. Be sure that all bolts purchased locally are a grade 5.

GC-STT DECALS

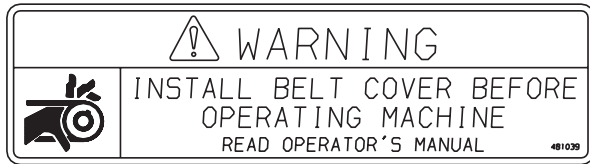

481039

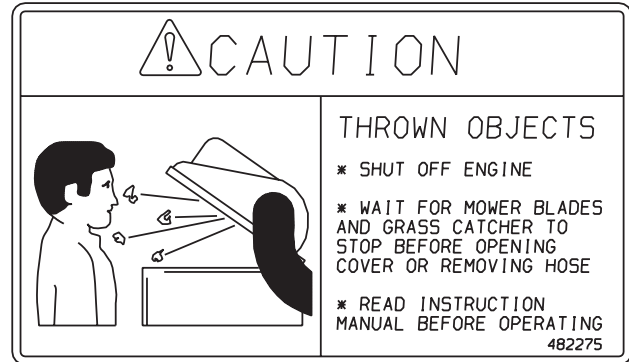

482275



481327

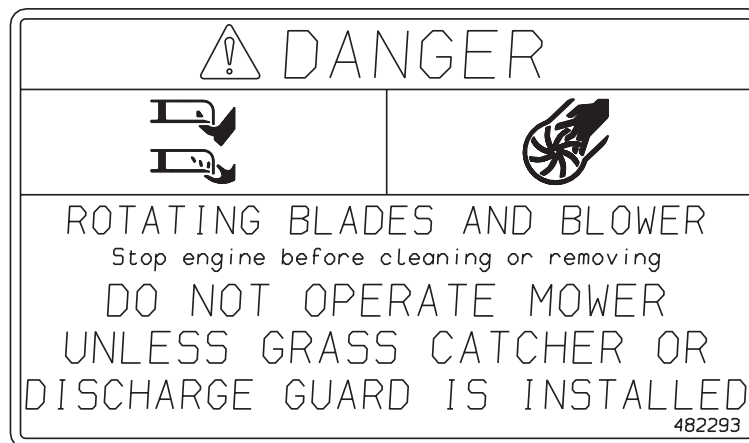

482293

NOTES

LIMITED WARRANTY- COMMERCIAL ACCESSORY

Any part of the Scag commercial accessory manufactured by Scag and found, in the reasonable judgment of Scag, to be defective in material or workmanship, will be repaired or replaced by an Authorized Scag Service Dealer without charge for parts and labor.

The Scag accessory, including any defective part, must be returned to an Authorized Scag Service Dealer within the warranty period. The expense of delivering the accessory to the dealer for warranty work and the expense of returning it back to the owner after repair or replacement will be paid for by the owner. Scag's responsibility in respect to claims is limited to making the required repairs or replacements, and no claim of breach of warranty shall be cause for cancellation or rescission of the contract of sale of any Scag machine. Proof of purchase will be required by the dealer to substantiate any warranty claim. All warranty work must be performed by an Authorized Scag Service Dealer.

This warranty is limited to 90 days from the date of original retail purchase for any Scag accessory that is used for commercial purposes, or any other income-producing purpose including rental use.

This warranty does not cover any accessory that has been subject to misuse, neglect, negligence, or accident, or that has been operated in any way contrary to the operating instructions as specified in the Operator's Manual. The warranty does not apply to any damage to the accessory that is the result of improper maintenance, or to any accessory or parts that have not been assembled or installed as specified in the Operator's Manual.

The warranty does not cover any accessory that has been altered or modified. In addition, the warranty does not extend to repairs made necessary by normal wear, or by the use of parts or accessories which, in the reasonable judgment of Scag, are either incompatible with the Scag mower or adversely affect its operation, performance or durability. This warranty does not cover engines and electric starters, which are warranted separately by their manufacturer.

Scag Power Equipment reserves the right to change or improve the design of any accessory without assuming any obligation to modify any accessory previously manufactured.

All other implied warranties are limited in duration to the 90 day warranty period. Accordingly, any such implied warranties including merchantability, fitness for a particular purpose, or otherwise, are disclaimed in their entirety after the expiration of the appropriate ninety day warranty period. Scag's obligation under this warranty is strictly and exclusively limited to the repair or replacement of defective parts and Scag does not assume or authorize anyone to assume any other obligation for them. Some states do not allow limitations on how long an implied warranty lasts, so the above limitation may not apply to you.

Scag assumes no responsibility for incidental, consequential or other damages including, but not limited to, expense for gasoline, oil, expense of delivering the machine to an Authorized Scag Service Dealer and expense of returning it back to the owner, mechanic's travel time, telephone or telegram charges, rental of a like product during the time warranty repairs are being performed, travel, loss or damage to personal property, loss of revenue, loss of use of the mower, loss of time, or inconvenience. Some states do not allow the exclusion or limitation of incidental or consequential damages, so the above limitation or exclusion may not apply to you.

This warranty gives you specific legal rights, and you may also have other rights which vary from state to state.

**© 2003
SCAG POWER EQUIPMENT
DIVISION OF METALCRAFT OF MAYVILLE, INC
WWW.SCAG.COM**

**PART NO. 03138
PRINTED 8-2003
PRINTED IN USA**

Free Manuals Download Website

<http://myh66.com>

<http://usermanuals.us>

<http://www.somanuals.com>

<http://www.4manuals.cc>

<http://www.manual-lib.com>

<http://www.404manual.com>

<http://www.luxmanual.com>

<http://aubethermostatmanual.com>

Golf course search by state

<http://golfingnear.com>

Email search by domain

<http://emailbydomain.com>

Auto manuals search

<http://auto.somanuals.com>

TV manuals search

<http://tv.somanuals.com>