

CE

GB

USE AND MAINTENANCE MANUAL

BC 90 (1+1)

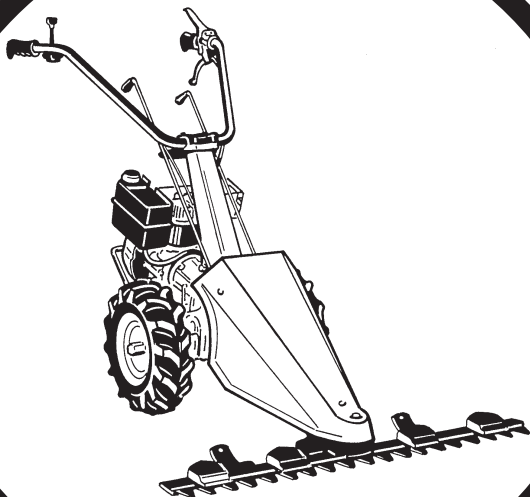

S.E.P.<sup>®</sup>

# ASSEMBLING INSTRUCTION FOR MOTOR-MOWER

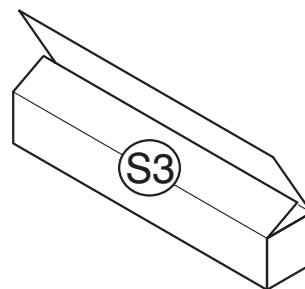
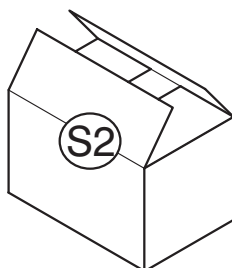
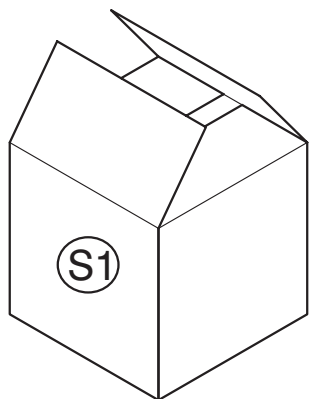

BOX	CONTENTS	WEIGHT (kg)
(S1)	MACHINE	46,5 ÷ 47
(S2)	BAR MECHANISM	9,8 ÷ 12,5
(S3)	SICKLE BAR	14 ÷ 21,5

## A POSITION THE HANDLEBAR TIGHTEN THE 4 SCREW

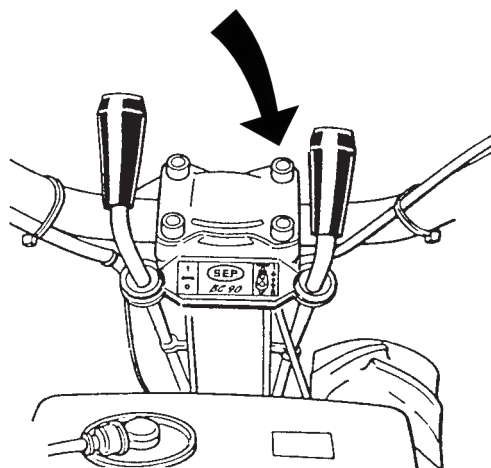
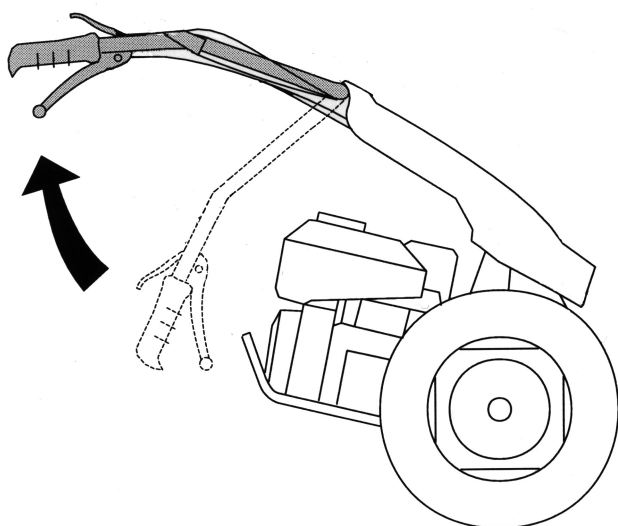

## B CONNECT SICKLE BAR

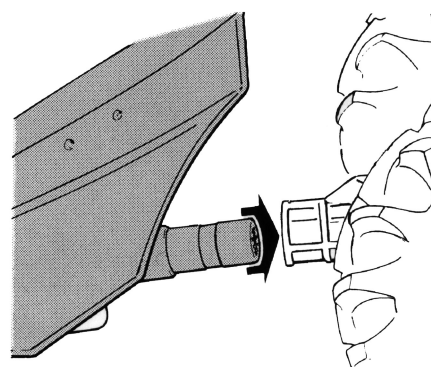
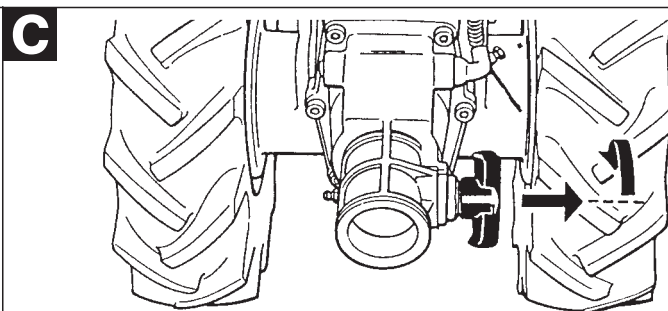
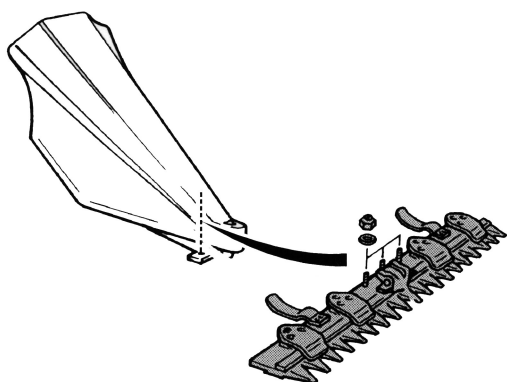

## MOTOR-MOWER

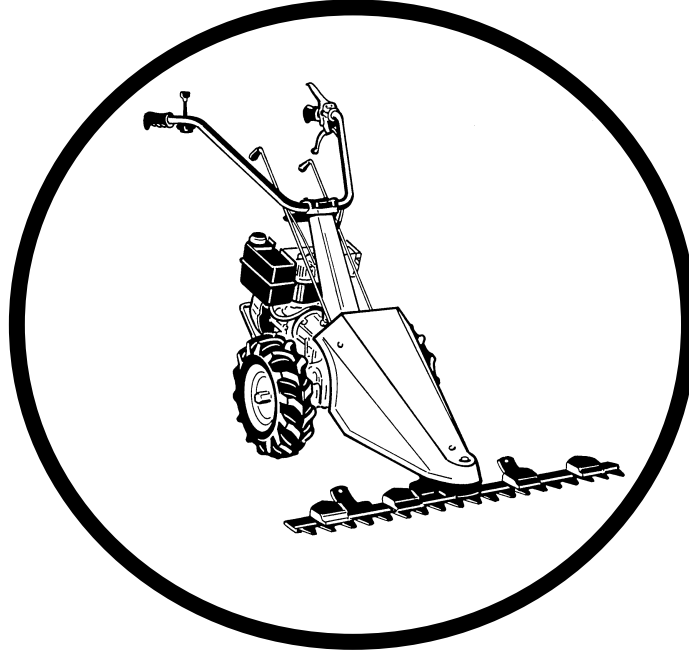

**BC 90 (1+1)**



**BEFORE USING THE MOTOR-MOWER  
CAREFULLY READ THE INSTRUCTIONS  
GIVEN IN THIS MANUAL**

---

## TABLE OF CONTENTS

	Page		Page
<b>INTRODUCTION</b> .....	<b>3</b>	<b>TRANSFER PRINTING - INSTRUCTIONS AND SAFETY</b> .....	<b>7</b>
<b>SAFETY REGULATIONS</b> .....	<b>3</b>	<b>MOTOR-MOWER CONTROLS</b> .....	<b>8</b>
GENERAL NOTICES .....	3	<b>OPERATING THE CONTROLS</b> .....	<b>8</b>
STARTING THE ENGINE .....	3	<b>OPERATING THE MOTOR-MOWER</b> .....	<b>10</b>
OPERATING OF THE MOTOR-MOWER.....	4	STARTING THE ENGINE.....	10
OPERATING OF ATTACHMENTS .....	4	STOPPING THE ENGINE .....	10
MAINTENANCE.....	4	<b>COUPLING ATTACHMENTS TO THE PTO</b> .....	<b>10</b>
<b>IDENTIFICATION DATA</b> .....	<b>5</b>	<b>MOUNTING THE 2<sup>ND</sup> WHEEL (UPON REQUEST)</b> .....	<b>11</b>
MOTOR-MOWER IDENTIFICATION .....	5	<b>MAINTENANCE</b> .....	<b>11</b>
ENGINE IDENTIFICATION.....	5	ENGINE .....	11
<b>EC MARKING</b> .....	<b>5</b>	OIL BATH AIR FILTER .....	11
<b>TECHNICAL SPECIFICATIONS</b> .....	<b>6</b>	GEARBOX AND TRANSMISSION .....	11
<b>ENGINE</b> .....	<b>6</b>	POWER TAKE OFF .....	12
STARTING.....	6	<b>CHECKS AND ADJUSTMENTS</b> .....	<b>12</b>
CLUTCH.....	6	CLUTCH LEVER.....	12
GEARS .....	6	<b>CUTTER BAR MOWER</b> .....	<b>13</b>
TRANSMISSION .....	6	GENERAL .....	13
POWER TAKE OFF (P.T.O.) .....	6	CUTTER BAR MOWER	
COUPLING OF ATTACHMENTS .....	6	TECHNICAL SPECIFICATIONS .....	13
HANDLEBARS .....	6	OPERATING CUTTER BAR MOWERS.....	13
WHEELS .....	6	CUTTER BAR MOWER ADJUSTMENTS.....	13
ACCESSORIES.....	6	CUTTER BAR MOWER MAINTENANCE .....	14
MASS .....	6	<b>EC CERTIFICATE OF CONFORMITY</b>	
DIMENSIONS.....	6		
<b>SAFETY DEVICE</b> .....	<b>7</b>		

## INTRODUCTION

- This manual provides Use and Maintenance instructions, technical specifications, and safety precautions for motor-mower:
  - model BC 90 (1+1)
 in the versions with gasoline engines.
- For the sake of clarity and ease of identification, the different motor-mower models are identified in this manual by means of the following codes:
  - **90** identifies motor-mower.
- The first section of this manual provides technical specifications and gives instructions relevant to the machine. The second section of the manual gives further details on individual attachments, and provides all specific operating instructions.
- Read this **USE** and **MAINTENANCE** Manual carefully before using your new motor-mower. This manual provides the most up-to-date information on your motor-mower available at the time of going to press. Manufacturer reserves the right to modify this document at any time without prior notice.
- **AFTER-SALES SERVICE.** Use only original spare parts. The use of non-original parts voids the warranty. When ordering spare parts, specify:
  - motor-mower serial number;
  - part code of spare part required;
  - quantity or number of parts required.

## SAFETY REGULATIONS

### GENERAL NOTICES

Any engine driven machine can become dangerous if used incorrectly.

Pay particular attention to the instructions in this manual marked:



#### WARNING

This symbol means that failure to observe the regulation could cause injury or even death to the operator.



#### PRUDENCE



Prudence is the Golden Rule to prevent accidents.



#### TRAINING

The motor-mower must only be used by responsible persons trained in the use of the machine and duly authorized to use it.



#### MACHINE AND ENGINE MANUALS



Read those **MANUALS** carefully before starting, using, servicing, refuelling or carrying out any work on the motor-mower.



#### DECALS

Read all the decals attached to the motor-mower and follow their prescriptions before starting, driving, refuelling or servicing the machine. Replace immediately any damaged or illegible decals.



#### SUITABLE CLOTHING

- Do not wear wide and flapping clothes that could be caught in moving parts.
- Always wear robust gloves when servicing the motor-mower or coupling attachments.
- Do not operate your motor-mower barefoot, wearing sandals or shorts. Wear heavy shoes and trousers.



#### PHYSICAL CONDITION

Do not drive the motor-mower if your physical condition is not suitable.



#### NOISE



In order to reduce the problems deriving from the noise of the machine:

- Do not work with the engine at maximum RPM range.
- Keep the blade head and the blade holder adjusted.
- When using the machine for a long time, use ear protections.



#### ENGINE RPM

Do not change the injection system in an attempt of increase maximum engine RPM.



#### FIRST AID



It is good operating practice to have a first aid box on the motor-mower.



## STARTING THE ENGINE

- Disengage all control levers before starting the motor. Keep your feet clear of the attachments fitted to the machine.
- Do not run the engine in a closed ambient where the exhaust gases can collect. They contain carbon monoxide that is highly toxic.
- Do not interfere with safety device (engine shut-off). Do not use the motor-mower if this safety device is missing or defective.
- Oil bath air filter (if fitted) - When delivered new, there is no oil in the air filter. Before using your motor-mower, add motor oil up to the marked level.



## OPERATING OF THE MOTOR-MOWER

- First of all, make sure that you know how to stop the engine in an emergency. Familiarize yourself with the controls and learn how to use your motor-mower correctly.
- Do not allow children or inexperienced persons to operate it.
- Do not use your motor-mower in proximity of other people, and in particular of children. Do not use it close to animals. Bear in mind that you are responsible for any damage or injury caused to persons or things.
- Keep your hands and feet clear of the cutter bar when in motion.
- Use your motor-mower only in daylight or with good artificial lighting. Operate it at walking pace. Do not run.
- Take particular care on slopes; operate only under safe and stable conditions. Do not work uphill or downhill; move across the slope instead. Take special care when turning.
- For obvious reasons, never work on slopes steeper than 30°.
- To ensure that gasoline fuelled engines are correctly lubricated, avoid working for long periods on slopes steeper than 20°.
- Do not operate the motor-mower if hoods or other safety devices are missing or defective.
- Keep your hands and feet clear of all attachments.
- Do not lift or transport your motor-mower with the engine running.
- Do not leave your motor-mower in closed ambients with fuel in the tank. Fuel vapor is a potential source of danger.
- Keep your motor-mower clean. Do not let grass and oil residues build up: these are a fire hazard.



## OPERATING OF ATTACHMENTS

- Check that the attachment coupled to the PTO functions correctly before starting the motor.

- Never use attachments coupled to the PTO in proximity of children or animals.
- Keep your hands and feet well clear of the attachment coupled to the PTO.



## MAINTENANCE

- Stop the engine and disconnect, for gasoline engines, the spark plug lead:
  - before checking or repairing your motor-mower;
  - in case of excessive vibrations (investigate cause immediately).
- Stop the engine before adjusting attachments.
- Periodically check that all nuts and bolts are tight.
- **Fuel is highly flammable.** Store fuel only in specifically designed containers. Refuel your motor-mower in the open. Do not smoke while refuelling.
- Complete refuelling before starting the engine. Do not remove the fuel cap or refuel when the engine is running or hot. In case of fuel spillage, do not start the engine. Push your motor-mower some distance away from where the spillage occurred before starting it.
- Replace the exhaust pipe if it becomes worn or damaged.

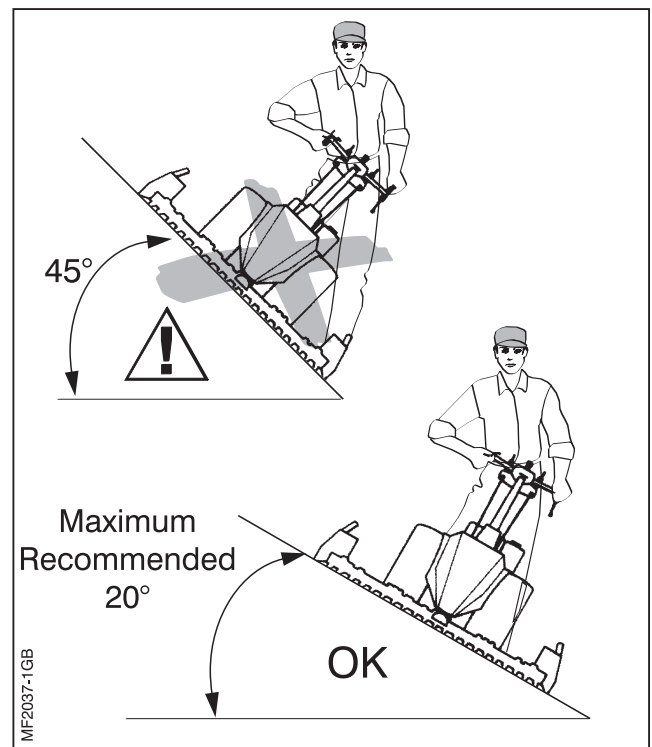
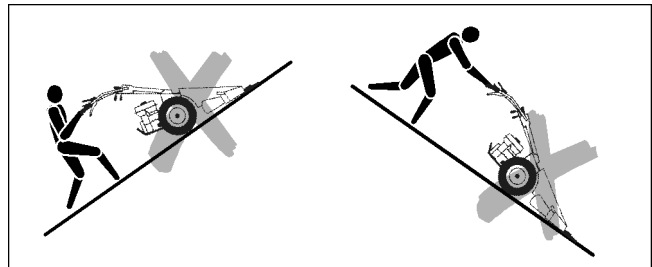

## IDENTIFICATION DATA

### MOTOR-MOWER IDENTIFICATION

The serial number is stamped on the engine side of the gear box of your motor-mower (see figure 1, item 1).

### ENGINE IDENTIFICATION





Refer to the engine Operation and Maintenance Manual.

### EC MARKING

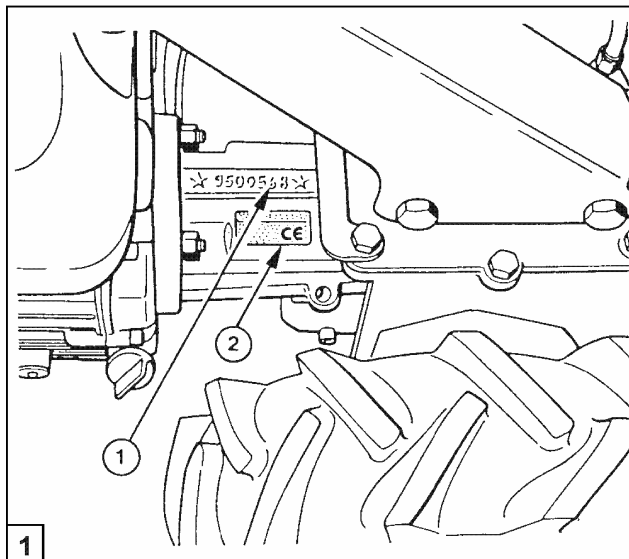
The motor-mower is marked EC in compliance with the Directive of the European Community Council 89/392/EEC and further amendments (see figure 1, part 2).

The summary of the EC marking related to 90 model is indicated below.



<p>(GB)</p> <p><b>TYPE OF MARKING</b> MOTOR-MOWER BC 90 (1+1)</p>	<p><b>NOISE AND VIBRATIONS</b></p> <p>Test conditions: - P.T.O.: Engaged</p>		
<p>Model: <b>BC 90 (1+1)</b> Progressiv unit number starting from <b>H301096</b> to <b>H301754</b> Progressiv unit number starting from <b>BA00001</b> (punched on the gearbox)</p>	<p><b>Sound pressure on operator's ears</b> <b>dB(A)</b></p>	<p><b>Acoustic power</b> <b>dB(A)</b></p>	<p><b>Acceleration on handgrip</b> <b>EN 1033 - 28662/1</b> <b>m/sec<sup>2</sup></b></p>
<p>(machine stationary on a grass surface)</p>	<p>(machine stationary on a concrete surface with an interposed elastic layer)</p>	<p>(machine running on a concrete surface with an interposed elastic layer)</p>	
<p>  VALPADANA S.p.A. 42018 SAN MARTINO IN RIO REGGIO EMILIA - ITALY                      Modello tipo: <b>BC 90 (1+1)</b>                      N. Serie: <b>AG30X00000</b>                      Mot.: <b>GC 160</b>                      Potenza: <b>3,7 kW/ 3600 rpm</b>                      Anno di Fabbricazione:                      Massa: <b>67,000 kg</b>  </p> <p>                     Engine:  <b>HONDA GC 160</b>                      Mass (weight):  <b>with wheels 3.50-6</b>  <b>with sickle bar mower</b>  <b>cm. 97</b> </p>	<p>88</p>	<p>104,5</p>	<p>13,5</p>
<p>  VALPADANA S.p.A. 42018 SAN MARTINO IN RIO REGGIO EMILIA - ITALY                      Modello tipo: <b>BC 90 (1+1)</b>                      N. Serie: <b>AG30X00000</b>                      Mot.: <b>LGA 226</b>                      Potenza: <b>4 kW/ 3600 rpm</b>                      Anno di Fabbricazione:                      Massa: <b>69,000 kg</b>  </p> <p>                     Engine:  <b>LOMBARDINI LGA 226</b>                      Mass (weight):  <b>with wheels 3.50-6</b>  <b>with sickle bar mower</b>  <b>cm. 97</b> </p>	<p>89</p>	<p>102,5</p>	<p>11,97</p>

S/N reading:      **AG30** type of machine  
                          **X**    year of manufacturing  
                          **00000** week of production  
                          **00000** progressive N° of production

## IDENTIFICATION DATA

### MOTOR-MOWER IDENTIFICATION

The serial number is stamped on the engine side of the gear box of your motor-mower (see figure 1, item 1).

### ENGINE IDENTIFICATION





Refer to the engine Operation and Maintenance Manual.

### EC MARKING

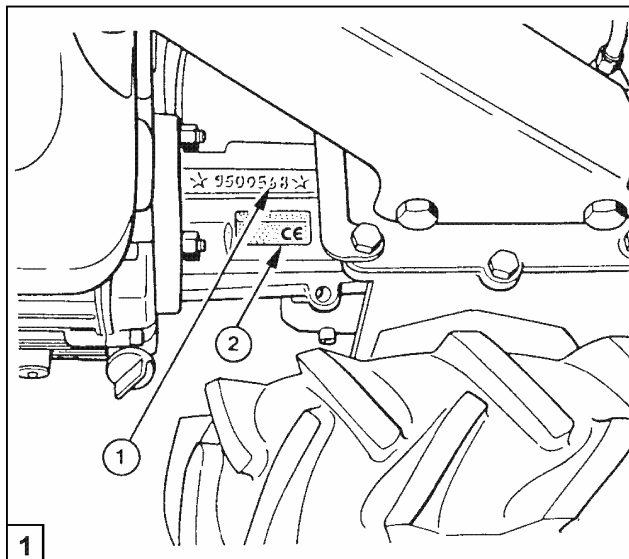
The motor-mower is marked EC in compliance with the Directive of the European Community Council 89/392/EEC and further amendments (see figure 1, part 2).

The summary of the EC marking related to 90 model is indicated below.



 <b>TYPE OF MARKING</b> <b>MOTOR-MOWER BC 90 (1+1)</b>	<b>NOISE AND VIBRATIONS</b>  Test conditions: - P.T.O.: Engaged		
Model: <b>BC 90 (1+1)</b> Progressiv unit number starting from <b>H301096</b> to <b>H301754</b> Progressiv unit number starting from <b>BA00001</b> (punched on the gearbox)	<b>Sound pressure on operator's ears dB(A)</b>	<b>Acoustic power dB(A)</b>	<b>Acceleration on handgrip EN 1033 - 28662/1 m/sec<sup>2</sup></b>
<div style="border: 1px solid black; padding: 5px;">            VALPADANA S.p.A.            42018 SAN MARTINO IN RIO            REGGIO EMILIA - ITALY  <hr/>           Modello tipo: <b>BC 90 (1+1)</b>            N. Serie: <b>AG30X00000</b>            Mot.: <b>GC 160</b>            Potenza: <b>3,7 kW/ 3600 rpm</b>            Anno di Fabbricazione:            Massa: <b>67,000 kg</b> </div> <div style="float: right; text-align: center;">             Engine:  <b>HONDA GC 160</b>            Mass (weight):  <b>with wheels 3.50-6</b>  <b>with sickle bar mower</b>  <b>cm. 97</b> </div>	88  <small>(machine stationary on a grass surface)</small>	104,5  <small>(machine stationary on a concrete surface with an interposed elastic layer)</small>	13,5  <small>(machine running on a concrete surface with an interposed elastic layer)</small>
<div style="border: 1px solid black; padding: 5px;">            VALPADANA S.p.A.            42018 SAN MARTINO IN RIO            REGGIO EMILIA - ITALY  <hr/>           Modello tipo: <b>BC 90 (1+1)</b>            N. Serie: <b>AG30X00000</b>            Mot.: <b>LGA 226</b>            Potenza: <b>4 kW/ 3600 rpm</b>            Anno di Fabbricazione:            Massa: <b>69,000 kg</b> </div> <div style="float: right; text-align: center;">             Engine:  <b>LOMBARDINI LGA 226</b>            Mass (weight):  <b>with wheels 3.50-6</b>  <b>with sickle bar mower</b>  <b>cm. 97</b> </div>	89	102,5	11,97

S/N reading:      **AG30** type of machine  
                          **X**    year of manufacturing  
                          **00000** week of production  
                          **00000** progressive N° of production



## TECHNICAL SPECIFICATIONS

### ENGINE

The motor-mower may be fitted with the following engines:

- HONDA GC 160; 4 stroke benzina;  
3,7 kW (5 HP); 160 cm<sup>3</sup>.
- LOMBARDINI LGA 226; 4 stroke benzina;  
4 kW (5,4 HP); 220 cm<sup>3</sup>.

### STARTING

Auto-winder device.

### CLUTCH

Cone type in oil bath with control lever on handlebars.

### GEARS

One forward gears and one reverse gear; gears are engaged through a lever fitted on handlebars.

VELOCITÀ MASSIMA IN km/h		
MODELLO	MARCIA	
	I	RM
(Pneumatici 3.50-6)	2,5	1,4

### TRANSMISSION

Oil bath gear box.

### POWER TAKE OFF

Mounted attachments are driven via an independent, single speed PTO engaged by a control lever on the handlebars.

Maximum PTO speed: 923 rpm (clockwise rotation).

## COUPLING OF ATTACHMENTS

Coupling of attachments to the PTO is obtained through a quick change fitting that provides for fast installation of the attachments, and does not require the use of bolts.

### HANDLEBARS

Adjustable in height with dampers.

### WHEELS

- Pneumatic tires with agricultural tread.
- Type and available sizes:  
**Tractor type:** 3.50-6
- Inflation pressure: 1,2 bar.

### ACCESSORIES

The motor-mower can be fitted with a wide range of additional easy-to-fit accessories.

These are, for instance, several types of iron wheels, watering pumps and sprayers, snowploughs, ploughs, trailers, water sprinkling trolleys, etc.

Refer to our catalogue for details about the various accessories available.

### MASS

Refer to the plate installed on the machine.

### DIMENSIONS

The overall dimensions of the motor-mower are shown in fig. 2.

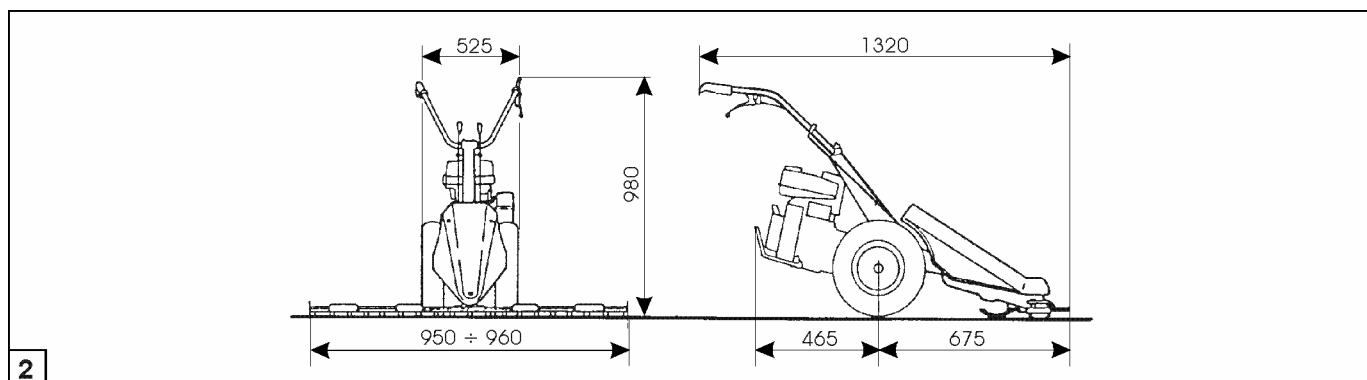

## SAFETY DEVICE

The machine is fitted with an engine shut-off device to ensure maximum safety in machine operation:

- Engine shut-off is an electrical device which stops the engine instantly if the handlebars are released.



### WARNING

Do not interfere with safety device (engine shut-off). Do not use the motor-mower if the safety device is missing or defective.

## TRANSFER PRINTING - INSTRUCTIONS AND SAFETY

Please find below the adhesive transfer printing shown on the machine.

For accident prevention purposes, they must always be clearly readable. Should they be damaged, it is compulsory to replace them by requesting the original spare part from the Manufacturer.

<p><b>STANDARD MACHINE</b></p> <p style="text-align: center;">Cod. 218181</p> <div style="display: flex; justify-content: center; align-items: center; gap: 10px;"> <div style="border: 1px solid black; padding: 5px; text-align: center;">1 ▲ 0</div> <div style="border: 1px solid black; padding: 5px; text-align: center;">   <i>BC 90</i> </div> <div style="border: 1px solid black; padding: 5px; text-align: center;">               1 ▲ 0 ▼ R         </div> </div> <p style="text-align: center;">CONTROL</p>		
<p style="text-align: center;">Cod. 219409</p> <div style="border: 1px solid black; padding: 5px; display: flex; justify-content: space-around;"> </div> <p style="text-align: center;">ACCIDENT PREVENTION</p>	<p style="text-align: center;">Cod. 219379</p> <div style="text-align: center;"> </div> <p style="text-align: center;">NOISE</p>	<p style="text-align: center;">Cod. 212813</p> <div style="border: 1px solid black; padding: 5px; text-align: center;"> <p style="font-size: 8px; margin: 0;">ADJUSTABLE KNIFE HEAD MESSERKOPF REGISTRIERBAR TÊTE DE LAME REGLABLE TESTA DI LAMA REGISTRABILE</p> </div> <p style="text-align: center;">KNIFE HEAD</p>

### SYMBOLS



Machine manual



Engine manual



Keep safety distance



Cutter bar



Direction



Be careful of tool cutting edges. Risk of accident

## MOTOR-MOWER CONTROLS

See fig. 3.

1. Clutch lever.
2. Engine stop lever.

3. Gear lever.
4. PTO control lever.
5. Throttle control lever.
6. PTO instant adaptor.

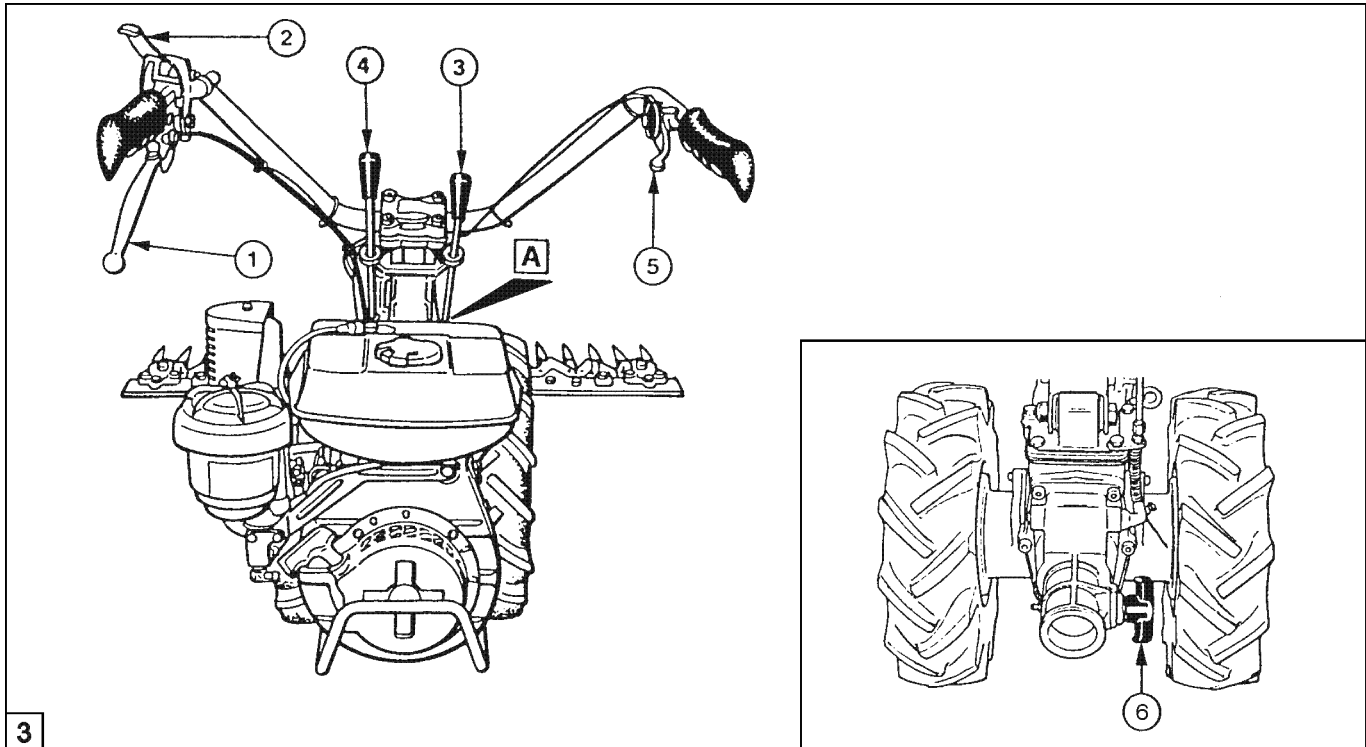

## OPERATING THE CONTROLS

### Clutch lever

(See figure 4)

- Lever (1) pulled up: clutch disengaged.
- Lever (1) released: clutch engaged.

### Engine stop lever

(See figure 4)

- Lever (2) pressed down: engine running.
- Lever (2) released: engine stopped.

Some gasoline motors can be stopped by means of a button (see the engine Operating and Maintenance manual); to stop the engine, for example with the lever of the motorstop locked in low position, press this button.

### Gear lever

Use the gear lever as instructed below (see figure 5):

- a. Turn the throttle control lever to idle position.
- b. Pull up clutch lever.
- c. Move the gear lever (1) to the required position (see the plate illustrated in detail A), and release it as soon as the gear is engaged.

- d. Gradually release the clutch lever while accelerating the engine.
- e. To disengage gear, pull up the clutch lever and move gear lever (1) to the neutral position.

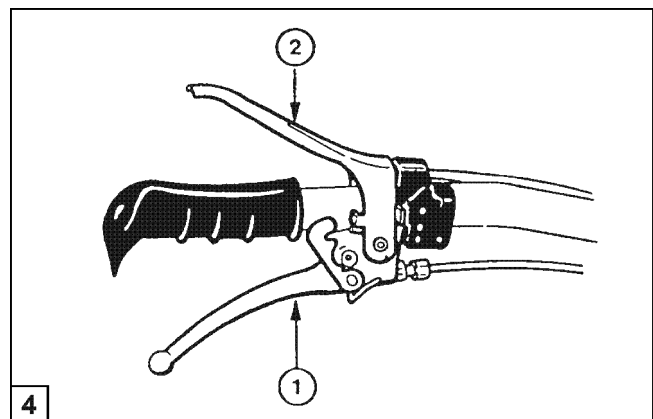

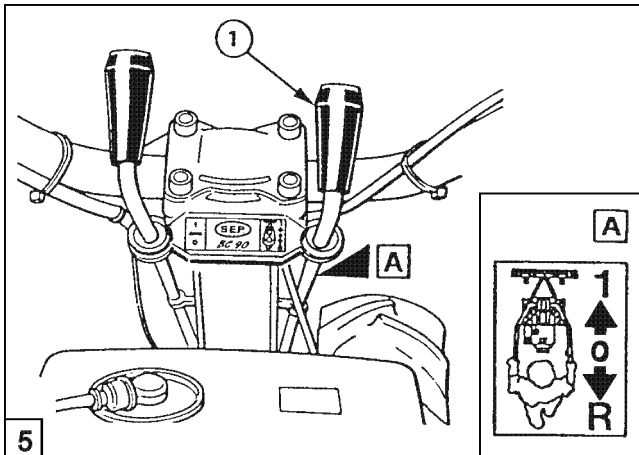

### Power Take Off (PTO) control lever

The Power Take Off (PTO) control lever engages the drive to the attachment.

To engage and disengage drive, proceed as follows (see fig. 6):

- Turn throttle control lever to idle position.
- Pull up clutch lever.
- Pull PTO control lever (1) and release it when drive is engaged (see plate in detail A.)
- Release the clutch lever while accelerating the engine.

#### CAUTION

The clutch lever must be released slowly to prevent damage to the drive. Do not start working with attachment loaded (into the soil).



#### WARNING

Check that the attachment fitted to the PTO is working correctly before you start the engine. Do not operate the PTO in proximity of children and/or animals.

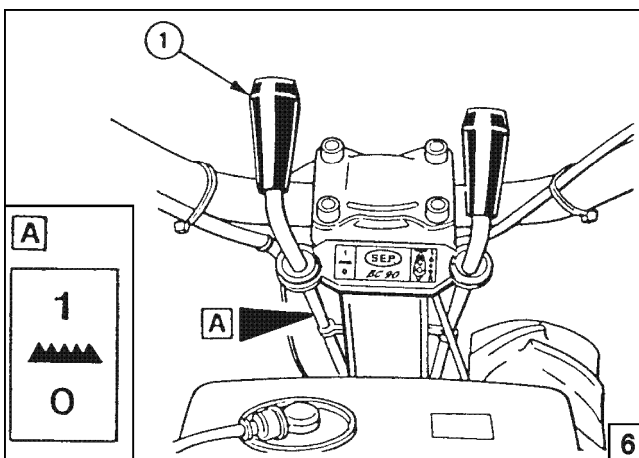

### Throttle control lever

(See figure 7)

- Lever (1) in up position: engine at idle.
- Lever (1) in down position: max engine rpm.

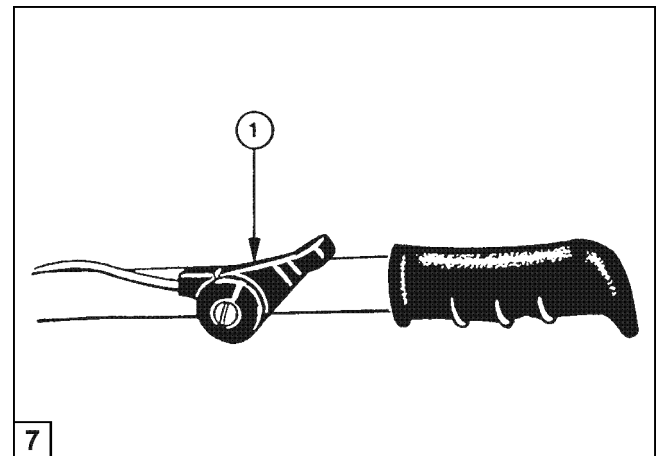

### Instant adaptor device for quick fit of the attachments to the PTO

It allows the instant fitting of the attachments to the PTO without using any wrench.

The knob (1) has 2 positions (see fig. 8):

- Free position: pull the knob (1) and lock it by rotating at 90°.
- Locking position: rotate at 90° the knob (1); if the coupling with the attachment is correct, the knob returns automatically in its original position locking the attachment itself.

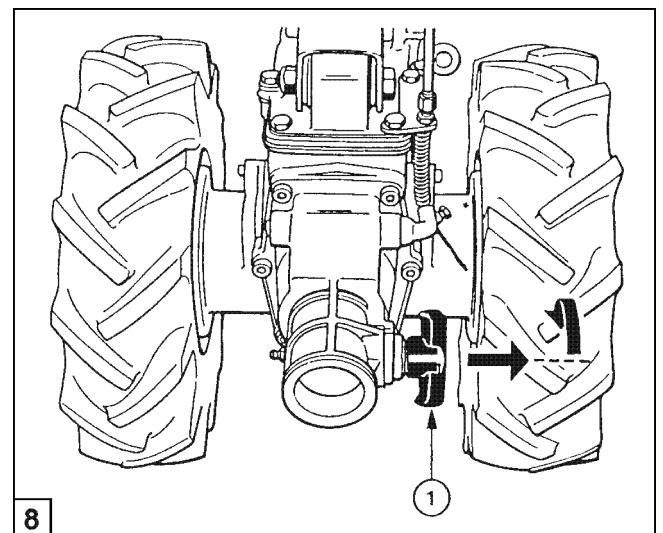

## OPERATING THE MOTOR-MOWER

### STARTING THE ENGINE

#### NOTE

See the engine Operating and Maintenance manual for all information regarding the engine.

#### CAUTION

**Oil bath air filter (if fitted)** - When delivered new, there is no oil in the air filter. Before using your motor-mower, add motor oil up to the marked level.

- Disengage all control levers before starting the engine
- Gasoline engines:** open the fuel cock.
- If cold starting the engine, use the choke.
- Press down the engine stop lever (figure 9, item 1).
- Pull clutch lever (2) fully up.
- Lock the clutch lever (1) in down position with locking device (3).
- Turn throttle control lever (4) a 1/4 turn.
- Grip the pull-rope handle and pull firmly and quickly. When the engine starts, allow the rope to wind back onto the reel slowly.

#### NOTE

Do not leave the clutch lever pulled up for an extended length of time after the engine has started. This could cause damage to the clutch.

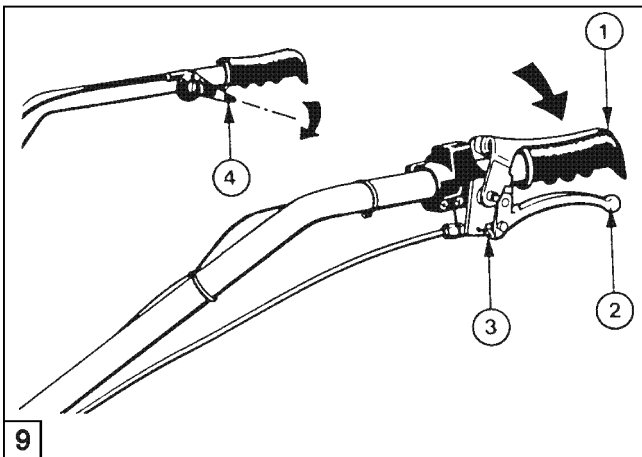

### STOPPING THE ENGINE

- Turn throttle control lever (figure 10, item 1) to idle position.
- Release the engine stop lever (2).
- Gasoline engines:** if you plan not to use your motor-mower for a long time, shut off the fuel cock.

- Gasoline engines:** if you plan not to use your motor-mower for a long time (over a week), drain the carburettor bowl.



#### WARNING

The engine stop lever (2) also operates as a safety device (emergency stop), and stops the engine as soon as it is released.

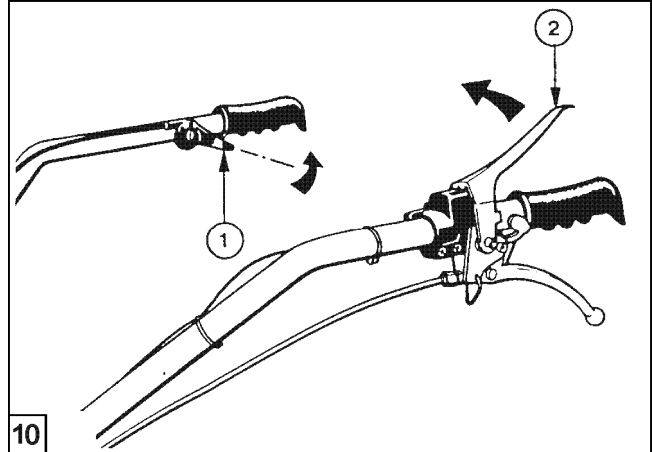

### COUPLING ATTACHMENTS TO THE PTO

The PTO is fitted with an instant adaptor device to fit attachments quickly and easily. Proceed as follows to fit your attachments (see fig. 11):

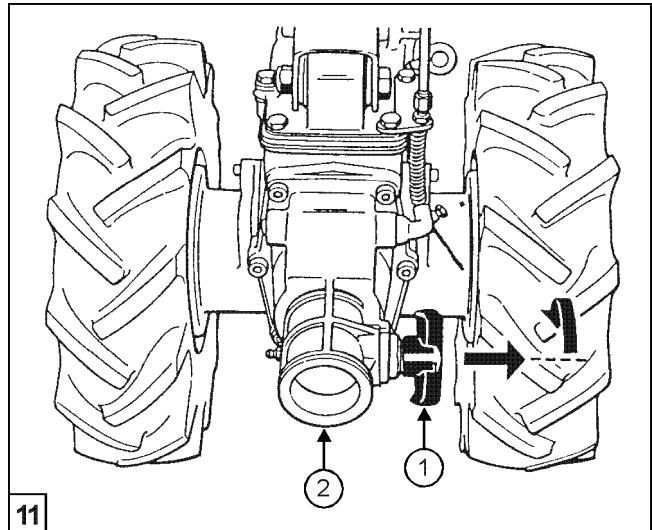

- Check that lever (1) is in disengaged position.
- Push the shaft of the attachment (1) into the PTO (2). Make sure that it engages fully.
- Raise the lever (1) to the engaged position. Check that the attachment is correctly locked.

## MOUNTING THE 2<sup>ND</sup> WHEEL (UPON REQUEST)

To mount the 2<sup>nd</sup> wheel kit, follow the below steps:

- Insert there spacer (3) into the wheel hexagon (1) and fix it by the safety pin (4).
- Install the second wheel (2) and fix it by its screw (6) and washer (5).
  - This procedure has to be done on both wheels.

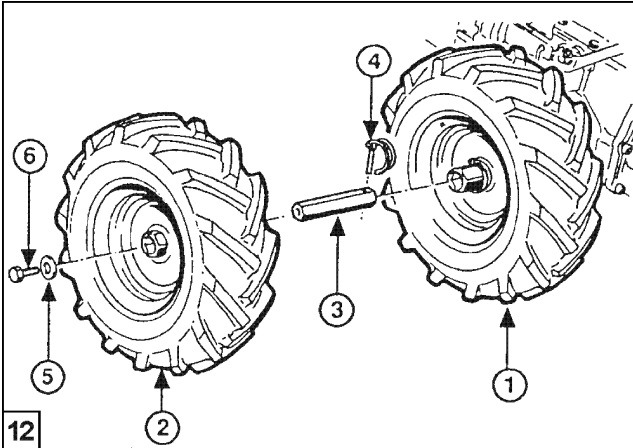

## MAINTENANCE

To ensure continuing reliability, use only original spare parts when overhauling or repairing your motor-mower.

### ENGINE

Make sure you do comply with the safety precautions contained in the engine Operation and Maintenance Manual.

#### During the first 50 hours (running in)

For the first 50 hours do not use the machine for heavy duty work. The following additional instructions must also be complied with during the running in period.

### DRY AIR FILTER

#### Every 8 hours

Clean carefully the cartridge and if is necessary replace it.

### GEARBOX AND TRANSMISSION

#### After the first 50 hours (running in)

Change the gear/transmission oil (see figure 13). Change the oil when the engine is hot to facilitate draining of oil.

- Remove the left wheel.
- Remove the oil dip-stick (1).

- Remove the oil drain plug (2) from the bottom of the gearbox (right side) and let the exhausted oil drain out. When fully drained, reinstall the plug (2).
- Fill up with new oil (1.2 litres) of the following types:
  - SAE 90 for ambient temperatures between -6 and +32°C;
  - SAE 140 for ambient temperatures between +32 and +60°C.

#### Every 20 hours

Check the level of the oil in the gearbox. The level must reach between the maximum and minimum notch on the dip-stick (1).

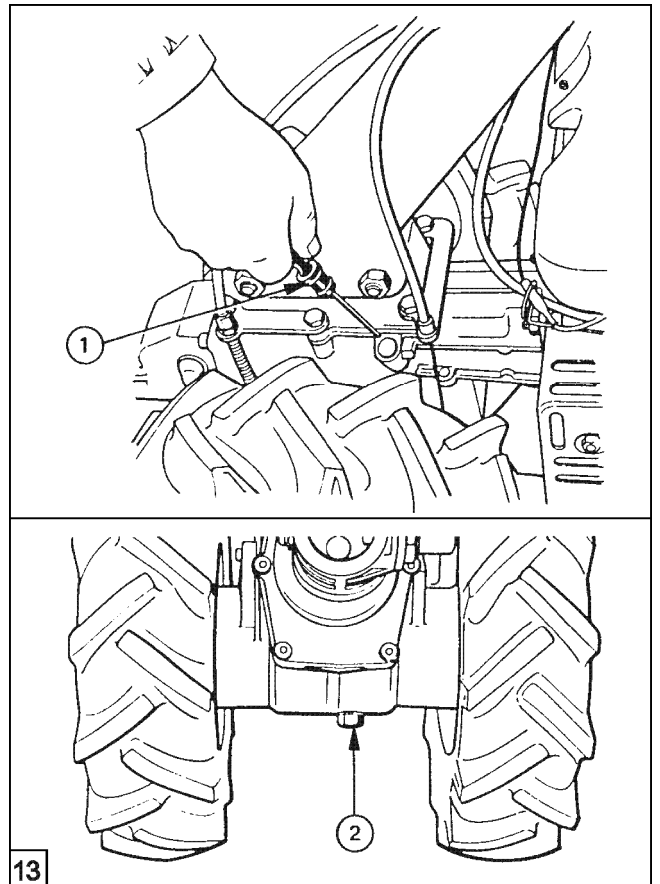

#### NOTE

Check the oil level with the motor cold and with the motor-mower on level ground.

**Every 300 hours**

Change the gearbox and transmission oil following the instructions given above in the paragraph covering running in.

**POWER TAKE OFF****Every 8 hours**

Grease the PTO (see figure 14, item 1).

Also grease the PTO every time you fit a new attachment.

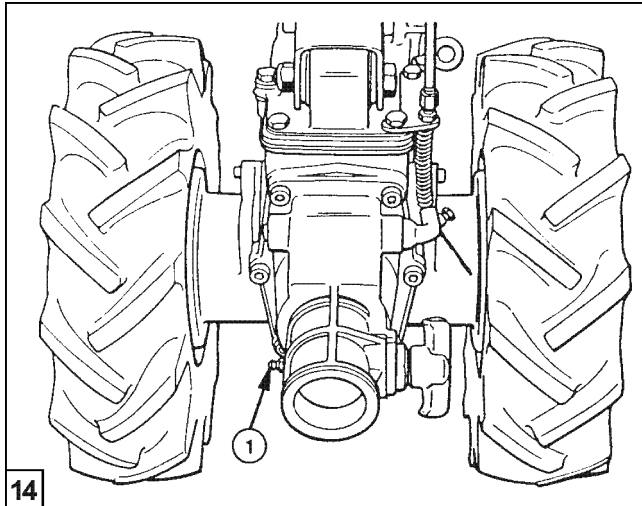
**CHECKS AND ADJUSTMENTS****CLUTCH LEVER**

The clutch lever must have a free play of about 5 to 6 mm before the clutch starts to disengage.

Insufficient play can cause clutch slip, while excess play can lead to failure to disengage fully. Adjust play by means of cable adjuster (see fig. 15, item. 1).

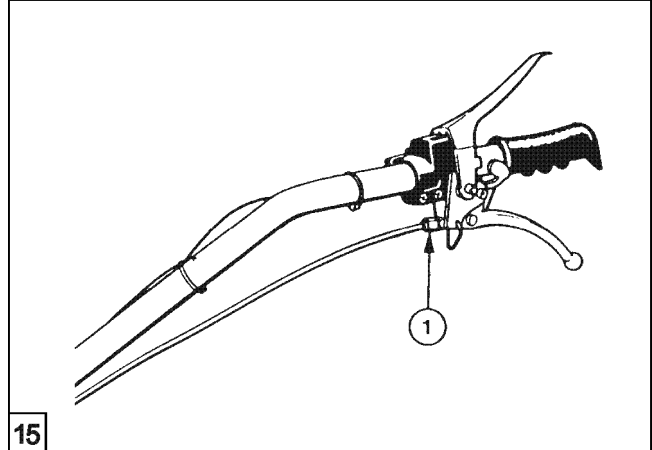

## CUTTER BAR MOWER



### WARNING

- When you transport your machine, and when you finish work, always fit the knife guard over the cutter bar.
- Keep your hands and feet clear of the cutter bar when in motion.
- Do not operate the motor-mower in proximity of children and/or animals.
- Stop the engine before cleaning the attachment.
- Stop the engine before adjusting the knife wear plate.



## GENERAL

Cutter bar mowers are available in various models and sizes and are ideal for mowing lawns of all types. Light weight and maneuverability make this attachment ideal for mowing large areas.

The cutter bar mower can be fitted with cutter bars finger type or E.S.M. type, all with grease mechanical drive.

## CUTTER BAR MOWER TECHNICAL SPECIFICATIONS

### Mechanical con-rod drive

- Sickle bar mowers  
cutting width: 95cm.
- E.S.M. bar mowers  
cutting width: 97cm.

### Sickle bar mower with cam mechanism

- Mulching bar mowers  
cutting width: 90cm.

## OPERATING CUTTER BAR MOWERS

The cutter bar attachment is driven via the PTO. Operate the PTO control lever as follows:

- Turn throttle control lever to idle position.
- Pull up clutch lever and engage first speed with gear lever.
- Pull PTO control lever. Release the lever when drive is engaged.

- Release the clutch slowly to start mowing and at the same time accelerate engine speed by means of throttle.

### CAUTION

Release the clutch gradually; do not release it when load is applied to the mower.

## CUTTER BAR MOWER ADJUSTMENT

The cutter bar mower requires a number of adjustments. The wear plate must be adjusted periodically to ensure efficient cutting.

The shoes can be adjusted to give the required cutting height. The knife mechanism can also be adjusted to minimize vibration and noise.

### Wear plate adjustment

At regular intervals check the play between the wear plate and the cutting knife.

Proceed as follows to reduce the gap if necessary.

### MULCHING TYPE BAR MOWERS (fig. 1)

- Loosen the two nuts (1) securing each of the four wear plates (2).
- Turn adjuster nut (3) of each wear plate to obtain correct knife movement.
- Tighten again the two securing nuts (1).

### SICKLE BAR MOWERS (fig. 2)

- Loosen the two screws (1) and (2) that secure each of the four wear plates (3).



- b. Loosen lock nut (5) and turn wear plate adjuster screw (4) to obtain correct sliding movement of the knife.
- c. Tighten again the securing nut (5) and the screws (1) and (2).

**MOWING BAR E.S.M. type S**

**NOTE**

The mowing bar type E.S.M. type S does not require any special adjustment as it is self-adjusting.

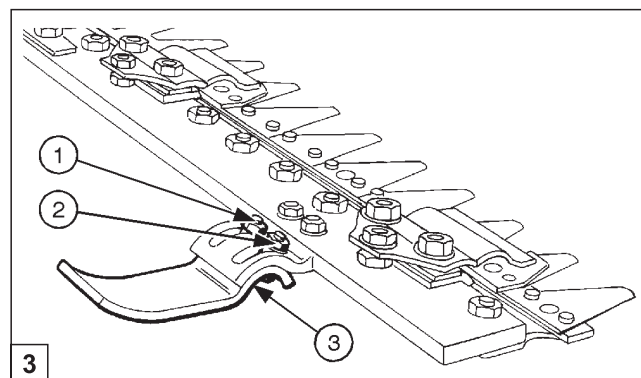
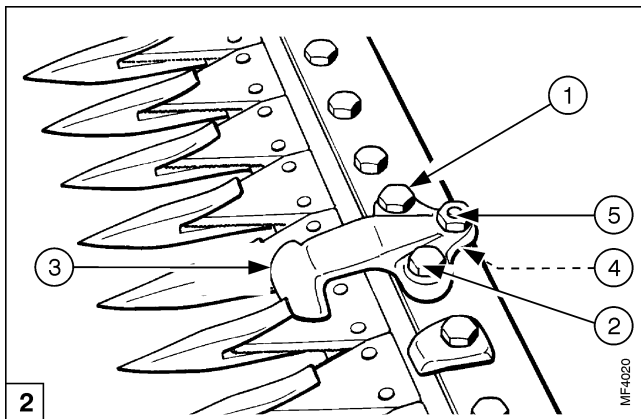
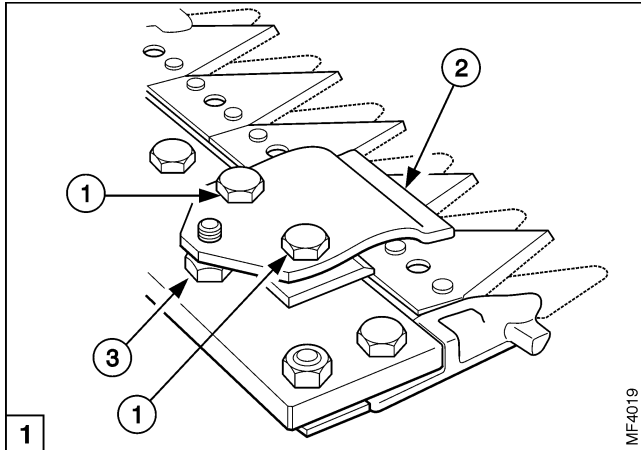

**Cutting height adjustment**

Proceed as follows to adjust cutting height (see fig. 2).

- a. Loosen the two screws (1) and (2) that fasten each skid.
- b. Adjust the two skids (3) as necessary to set the required cutting height.
- c. Tighten again the screws (1) and (2) fastening each skid.

**Knife mechanism adjustment**

At regular intervals check the play between the knife and the roller.

If play becomes excessive, adjust as follows (see figure 3):

- a. Loosen bolts (1).
- b. Turn adjuster screws (2) until play between roller (3) and push-rod is as required.
- c. Tighten bolts (1) again.

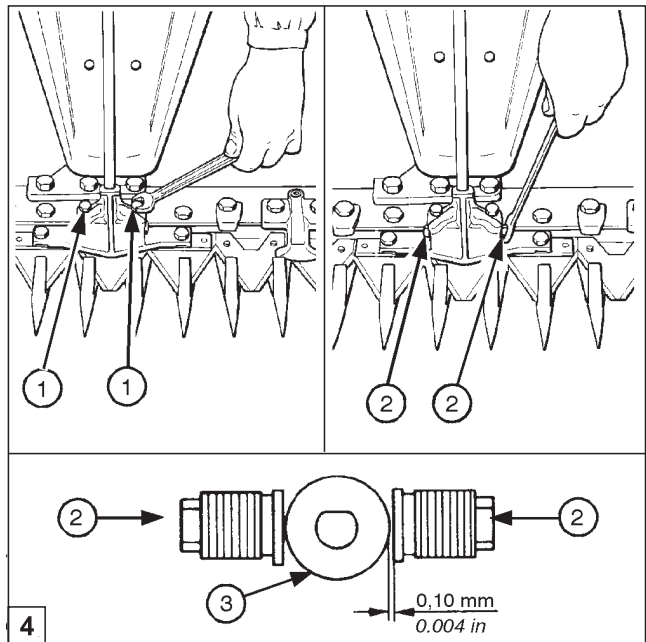

**Cam mechanism movement**

The coupling between roller and knife mechanism does not have adjustment; in case of excessive free play the wear parts must be substitute.

## CUTTER BAR MOWERS MAINTENANCE

### MECHANICAL CON-ROD DRIVE

#### Lubrication

**After the first 5 hours of work, and subsequently after every 10 hours, grease the mower mechanism at points (1) and (2) as shown in fig.5.**

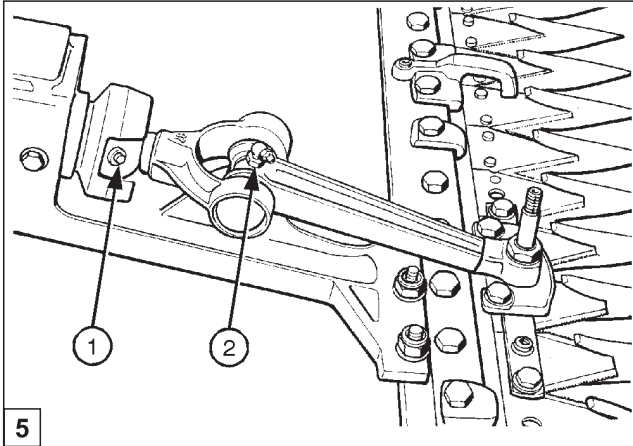

### CAM MECHANISM MOVEMENT

#### Lubrication

Greasing or lubrication points are not available in this system; it is however suggested to clean the coupling between roller and knife mechanism after its use. In order to avoid oxidation during long period of not use of the sickle bar it is suggested to lubricate roller and knife mechanism before storage.

# CE

(GB)

## EC Certificate of Conformity

According to ECC 89/392 Directives and successive modifications

**VALPADANA S.p.A.**  
**42018 SAN MARTINO IN RIO (RE) ITALY**

Declare on their own responsibility, that the machine

**MOTOR-MOWER**

Brand: **S.E.P.**

Type: **BC 90 (1+1)**

from machine serial n° **AG30X00000**◇

from machine chassis n° **H301096** a **H301754\***

from machine chassis n° **BA00001\***

(◇ see EC plate)

(\* see punching)

Conforms to the basic Safety and Health Requirements as stated in  
**ECC 89/392 Directives**, and successive modifications.

In order to verify the correct application of the aforementioned  
Directives, the following Conforming Standards were consulted:  
**pr EN 12733**

San Martino in Rio, 01.11.2001

**VALPADANA S.p.A.**  
**Il Legale Rappresentante**  
Petit Bon Eros



**VALPADANA S.p.A.**  
Società unipersonale appartenete al Gruppo Industriale Argo S.p.A.  
**42018 SAN MARTINO IN RIO (RE) ITALY**  
**Via Don Pasquino Borghi, 6**  
**Tel. 0522 73.17.11 - Fax 0522 73.17.31**



®

**VALPADANA S.p.A.**

Società unipersonale appartenente al Gruppo Industriale Argo S.p.A.

42018 S. MARTINO IN RIO (RE) ITALY

Via Don Pasquino Borghi, 6

TEL. 0522 73.17.11 - FAX 0522 73.17.31

E-MAIL: [infosep@sep.it](mailto:infosep@sep.it) - <http://www.sep.it>



A R G O

**Gruppo Industriale ARGO**

## Free Manuals Download Website

<http://myh66.com>

<http://usermanuals.us>

<http://www.somanuals.com>

<http://www.4manuals.cc>

<http://www.manual-lib.com>

<http://www.404manual.com>

<http://www.luxmanual.com>

<http://aubethermostatmanual.com>

Golf course search by state

<http://golfingnear.com>

Email search by domain

<http://emailbydomain.com>

Auto manuals search

<http://auto.somanuals.com>

TV manuals search

<http://tv.somanuals.com>