



SE4

ROTARY MOWER

Rev 09-05

S/N 16874 -Current

Part No.00760866P

PART'S MANUAL



An Operator's Manual was shipped with the equipment in the Manual Canister. This Operator's Manual is an integral part of the safe operation of this machine and must be maintained with the unit at all times. **READ, UNDERSTAND, and FOLLOW** the Safety and Operation Instructions contained in this manual before operating the equipment. If the Operator's Manual is not with the equipment, contact your dealer or Servis-Rhino (800-446-5158) to obtain a Free copy before operating the equipment.

ATENCIÓN!

LEA EL INSTRUCTIVO

Si No Lee Ingles, Pida Ayuda a Alguien Que Si Lo Lea Para Que le Traduzca las Medidas de Seguridad.



RHINO®

1020 S. Sangamon Ave.
Gibson City, IL 60936
800-446-5158

Email: parts@servis-rhino.com

© 2005 Alamo Group Inc.



TO THE OWNER/OPERATOR/DEALER





All implements with moving parts are potentially hazardous. There is no substitute for a cautious, safe-minded operator who recognizes the potential hazards and follows reasonable safety practices. The manufacturer has designed this implement to be used with all its safety equipment properly attached to minimize the chance of accidents.

BEFORE YOU START!! Read the safety messages on the implement and shown in your manual.
Observe the rules of safety and common sense!



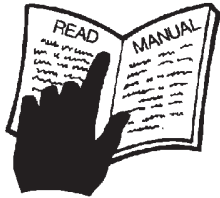



DANGER

FAILING TO FOLLOW SAFETY MESSAGES AND OPERATING INSTRUCTIONS CAN CAUSE SERIOUS BODILY INJURY OR EVEN DEATH TO OPERATOR AND OTHERS IN THE AREA.

| | | | |
|---|--|---|---|
| <p>1. </p> | <p>2. NO RIDERS, NO CHILDREN OPERATORS </p> | <p>3. USE SAFETY SHOES, HARD HAT, SAFETY GLASSES, SEAT BELTS, & ROPS </p> | <p>4. BLOCK UP SECURELY BEFORE WORKING UNDER. </p> |
|---|--|---|---|

- Study and understand Operator's Manuals, Safety Signs, and Instructional Decals for tractor & flail mower to prevent misuse, abuse, & accidents. Practice before operating mower in a confined area or near passersby.
 - Learn how to stop engine suddenly in an emergency. Be alert for passersby and especially children.
- Allow no children on or near implement or tractor. Allow no riders on tractor or implement. Falling off can cause serious injury or death from being runover by tractor or mower or contact with Flail Mower Blades.
- Operate only with tractor having Roll-Over Protective Structure (ROPS) and with seatbelt fastened securely and snugly to prevent injury and possible death from falling off or tractor overturn. Personal Protective Equipment such as Hard Hat, Safety Glasses, Safety Shoes, and Ear Plugs are recommended.
- Block up or support raised machine and all lifted components securely before putting hands or feet under or working underneath any lifted component to prevent crushing injury or death from sudden dropping or inadvertent operation of controls. Make certain that area is clear before lowering or folding.
- Before transporting, put Lift Lever in detent or full-lift position. Install Transport Safety Devices securely on folding implements. Slow down when turning and on hillsides.
 - Install **Restrictor in folding circuit to slow down lowering and unfolding if action is faster than is desirable.
- Make certain that SMV sign, Warning Lights, and Reflectors are clearly visible. Follow local traffic codes.
- Never operate with Flail Mower or Folding Section raised if passersby, bystanders or traffic are in the area to reduce possibility of injury or death from objects thrown by Blades under Shields or implement structure.
- Before dismounting, secure flail mower in transport position or lower to ground.
 - Put tractor in park or set brake, disengage PTO, stop engine, remove key, and wait until noise of rotation has ceased to prevent entanglement in rotating parts which may cause injury or death.
 - Never mount or dismount a moving vehicle. Crushing from runover may cause injury or death.

| | | | |
|--|--|--|--|
| <p>5. TRANSPORT SAFELY, LOCK UP. </p> | <p>6. USE SMV, LIGHTS, & REFLECTORS. </p> | <p>7. DO NOT OPERATE WITH MOWER OR WING RAISED. </p> | <p>8. DO NOT MOUNT OR DISMOUNT WHILE MOVING. </p> |
|--|--|--|--|

WARRANTY INFORMATION:

Read and understand the complete Warranty Statement found in this Manual. Fill out the Warranty Registration Form in full and return it within 30 Days. Make certain the Serial Number of the Machine is recorded on the Warranty Card and on the Warranty Form that you retain. The use of "will-fit" parts will void your warranty and can cause catastrophic failure with possible injury or death.

PARTS SECTION

PARTS ORDERING GUIDE

The following instructions are offered to help eliminate needless delay and error in processing purchase orders for the equipment in this section.

1. The Parts Section is prepared in logical sequence and grouping of parts that belong to the basic machine featured in this manual. Part Numbers and Descriptions are given to help locate the parts and quantities required.
2. The Purchase Order must include the name and address of the person or organization ordering the parts, who should be charged, and if possible, the serial number of the machine for which the parts are ordered.
3. The Purchase Order must clearly list the quantity of each part, the complete and correct part number (be sure to include all periods), and the basic name of the part.
4. The Manufacturer reserves the right to substitute parts where applicable.
5. Some parts are unlisted items which are special production items not normally stocked and are subject to special handling. Request a quotation for such parts before sending a Purchase Order.
6. The Manufacturer reserves the right to change prices without prior notice.

NOTE: Please refer to The Safety Section in the front of this Manual for the proper Part Number when ordering Replacement Safety Decals.



For maximum safety and to guarantee optimum product reliability, always use genuine Servis-Rhino Parts. The use of inferior replacement parts may cause premature or catastrophic failure which could result in serious injury or death. Direct any questions regarding parts to:



RHINO®
1020 S. Sangamon Ave.
Gibson City, IL 60936
800-446-5158
Email: parts@servis-rhino.com

PART NAME INDEX

| | |
|---|----|
| DRIVELINE ASSEMBLY S/N 16873 -BELOW Rev 10-04 | 8 |
| DRIVELINE ASSEMBLY S/N 16874 -CURRENT Rev 09-05 | 10 |
| FRONT DEFLECTORS ASSEMBLY | 11 |
| GEARBOX ASSEMBLY | 6 |
| HYDRAULIC RELIEF ASSEMBLY (OPTION) | 13 |
| MAIN ASSEMBLY | 4 |
| OFFSET ADAPTER (OPTION) | 14 |
| REAR DEFLECTORS ASSEMBLY | 12 |
| SAFETY DECAL SHEETS | 15 |

MAIN ASSEMBLY

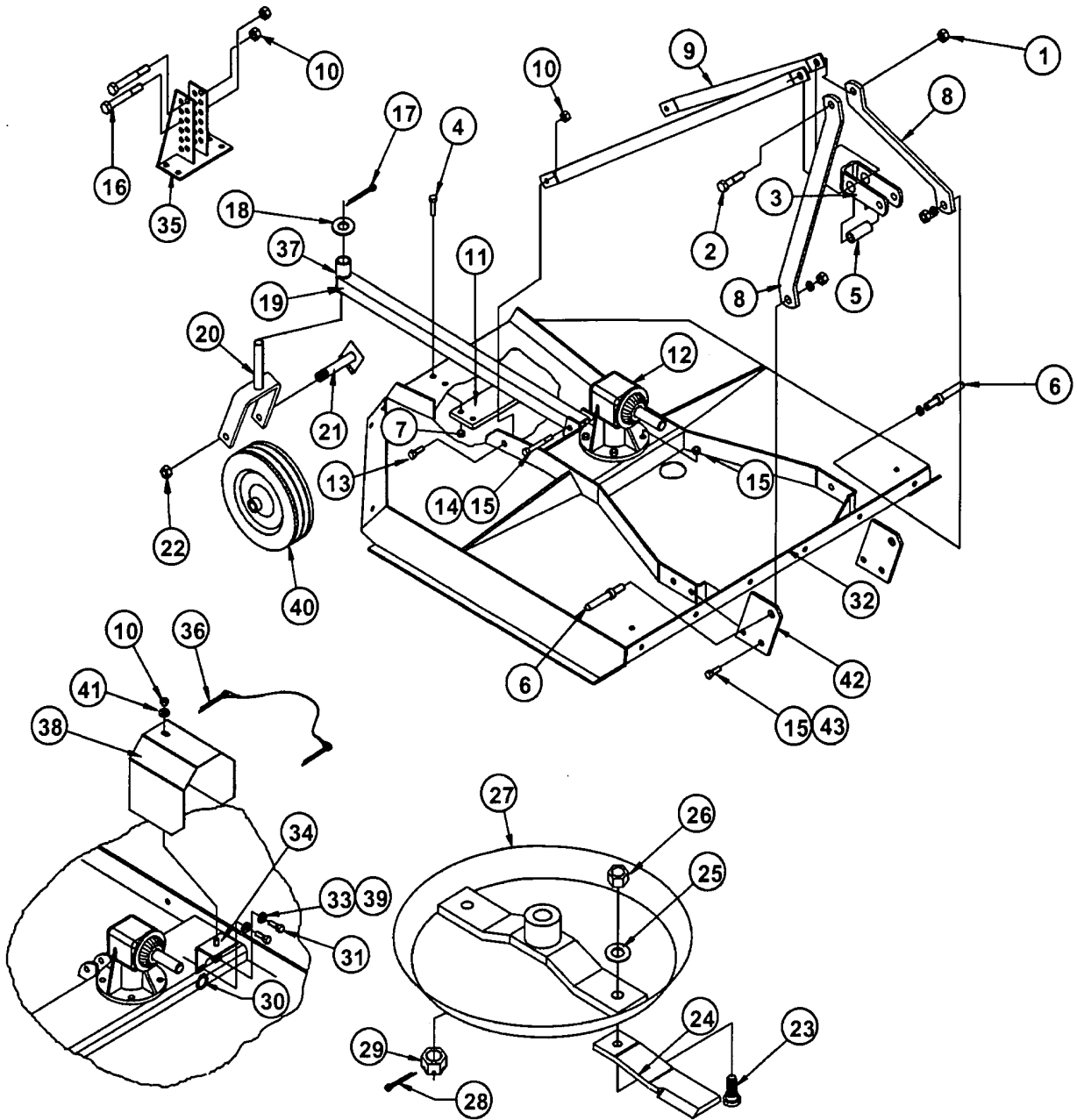

MAIN ASSEMBLY

| ITEM | PART NO. | QTY. | DESCRIPTION |
|------|-----------------|------|----------------------|
| | 00773753 | - | MAIN ASSEMBLY |
| 1 | 00770773 | 1 | LOCKNUT |
| 2 | 00770772 | 1 | BOLT |
| 3 | 00757949R | 1 | BAR TOP LINK |
| 4 | 00770781 | 4 | BOLT |
| 5 | 00766542 | 1 | BUSHING |
| 6 | 00603500 | 2 | HITCH PIN (CAT 1) |
| 7 | 00770777 | 4 | LOCKNUT |
| 8 | 00766505 | 2 | A-FRAME BAR |
| 9 | 00773564 | 2 | REAR BRACE |
| 10 | 00755881 | 5 | LOCKNUT |
| 11 | 00766610 | 1 | MOUNTING FLAT |
| 12 | 00761655P | 1 | GEARBOX |
| 13 | 00762365 | 2 | BOLT |
| 14 | 02957510 | 1 | BOLT |
| 15 | 00768968 | 9 | LOCKNUT |
| 16 | 02963669 | 2 | BOLT |
| 17 | 00036900 | 1 | COTTER PIN |
| 18 | 15B2000 | 1 | WASHER |
| 19 | 00773768 | 1 | TAILWHEEL BEAM |
| 20 | 00773565R | 1 | CASTER FORK |
| 21 | 00773566 | 1 | SPINDLE |
| 22 | 9143009 | 1 | LOCKNUT |
| 23 | 00761402 | 2 | BLADE BOLT |
| 24 | 00773812 | 2 | SUCTION BLADE |
| 25 | 00761535 | 2 | WASHER |
| 26 | 00750226 | 2 | LOCKNUT |
| 27 | 00766590R | 1 | DISHPAN |
| 28 | 00606000 | 1 | COTTER PIN |
| 29 | 00758692 | 1 | SLOTTED NUT |
| 30 | 7192 | 1 | SNAP RING |
| 31 | 02958784 | 2 | BOLT |
| 32 | 00773755R | 1 | MAIN FRAME |
| 33 | 00762423 | 2 | WASHER |
| 34 | 00772590 | 1 | SHIELD BRACKET |
| 35 | 00766611 | 1 | GAUGE WHEEL MOUNT |
| 36 | 00770066 | 1 | CABLE & PINS ASSY |
| 37 | 001465 | 1 | GREASE FITTING |
| 38 | 00772588 | 1 | SHIELD PLATE |
| 39 | 03101646 | 2 | LOCKWASHER |
| 40 | 00773567 | 1 | TIRE RIM ASSEMBLY |
| 41 | 00766086 | 1 | FLATWASHER |
| 42 | 00772291 | 2 | HITCH LUG |
| 43 | 02958788 | 4 | BOLT |

SE4 (Oct-04) S/N 16874 -Current Rev 09-05

GEARBOX ASSEMBLY

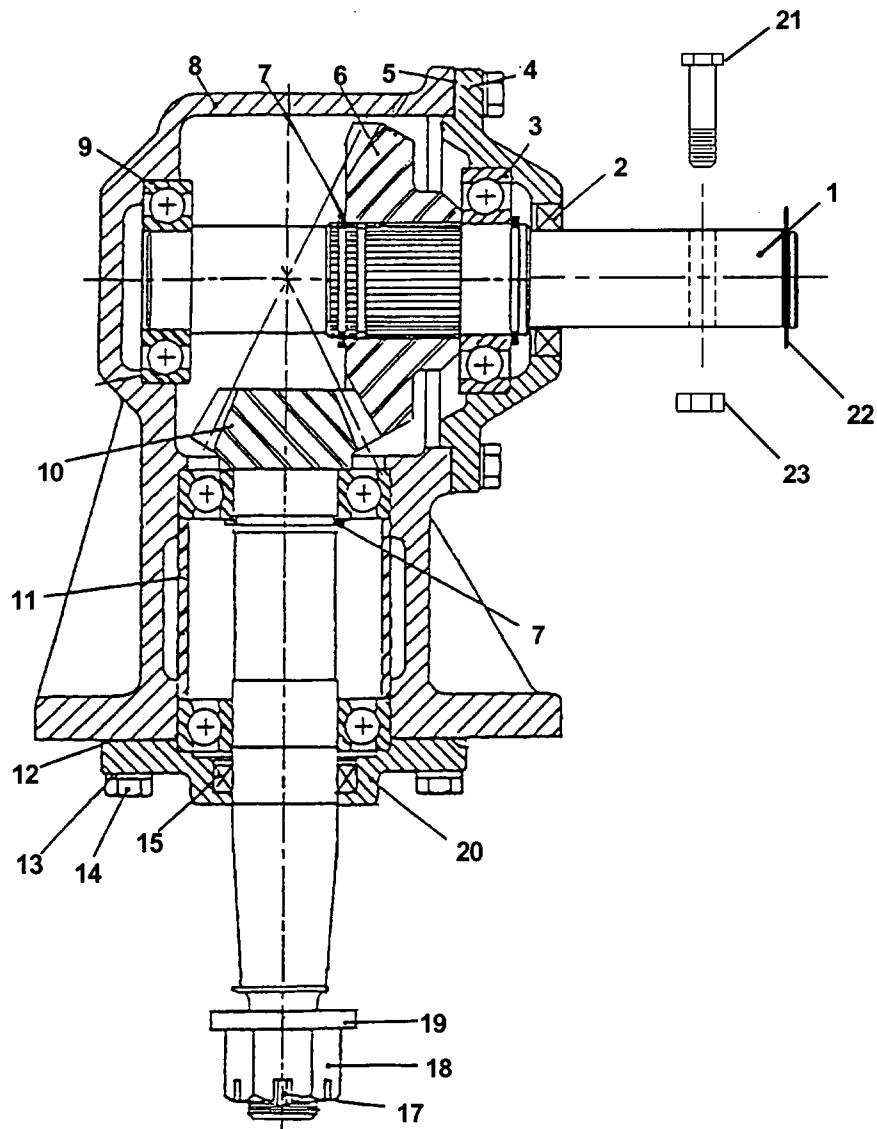

GEARBOX ASSEMBLY

| ITEM | PART NO. | QTY. | DESCRIPTION |
|------|-----------------|------|------------------------|
| | 00761655 | - | GEARBOX ASSY |
| 1 | 00564700 | 1 | INPUT SHAFT |
| 2 | 00564200 | 1 | SEAL |
| 3 | 00563700 | 3 | BALL BEARING |
| 4 | 00564300 | 1 | INPUT CAP |
| 5 | 00564400 | AR | GASKET |
| 6 | 00752481 | 1 | INPUT GEAR |
| 7 | 00564100 | 3 | RETAINING RING |
| 8 | 00563900 | 1 | HOUSING |
| 9 | 00564800 | 1 | BEARING |
| 10 | 00752480 | 1 | OUTPUT PINION & SHAFT |
| 11 | 00757682 | 1 | BEARING SPACER |
| 12 | 00760928 | AR | GASKET .25 |
| | 00760929 | AR | GASKET .10 |
| 13 | 02161100 | 10 | LOCKWASHER |
| 14 | 00011400 | 10 | BOLT |
| 15 | 00563500 | 1 | SEAL |
| 17 | 00606000 | 1 | COTTER PIN |
| 18 | 7202 | 1 | SLOTTED NUT |
| 19 | 6192 | 1 | WASHER |
| 20 | 00757683 | 1 | OUTPUT CAP |
| 21 | 7A81324 | 1 | BOLT |
| 22 | 7192 | 1 | RETAINING RING |
| 23 | 00001800 | 1 | LOCKNUT |
| | 00765444 | 1qt | QT,ALAMO 000 GEAR LUBE |

SE4 (Oct-04) S/N 16874 -Current Rev 09-05

DRIVELINE ASSEMBLY S/N 16873 -BELOW Rev 10-04

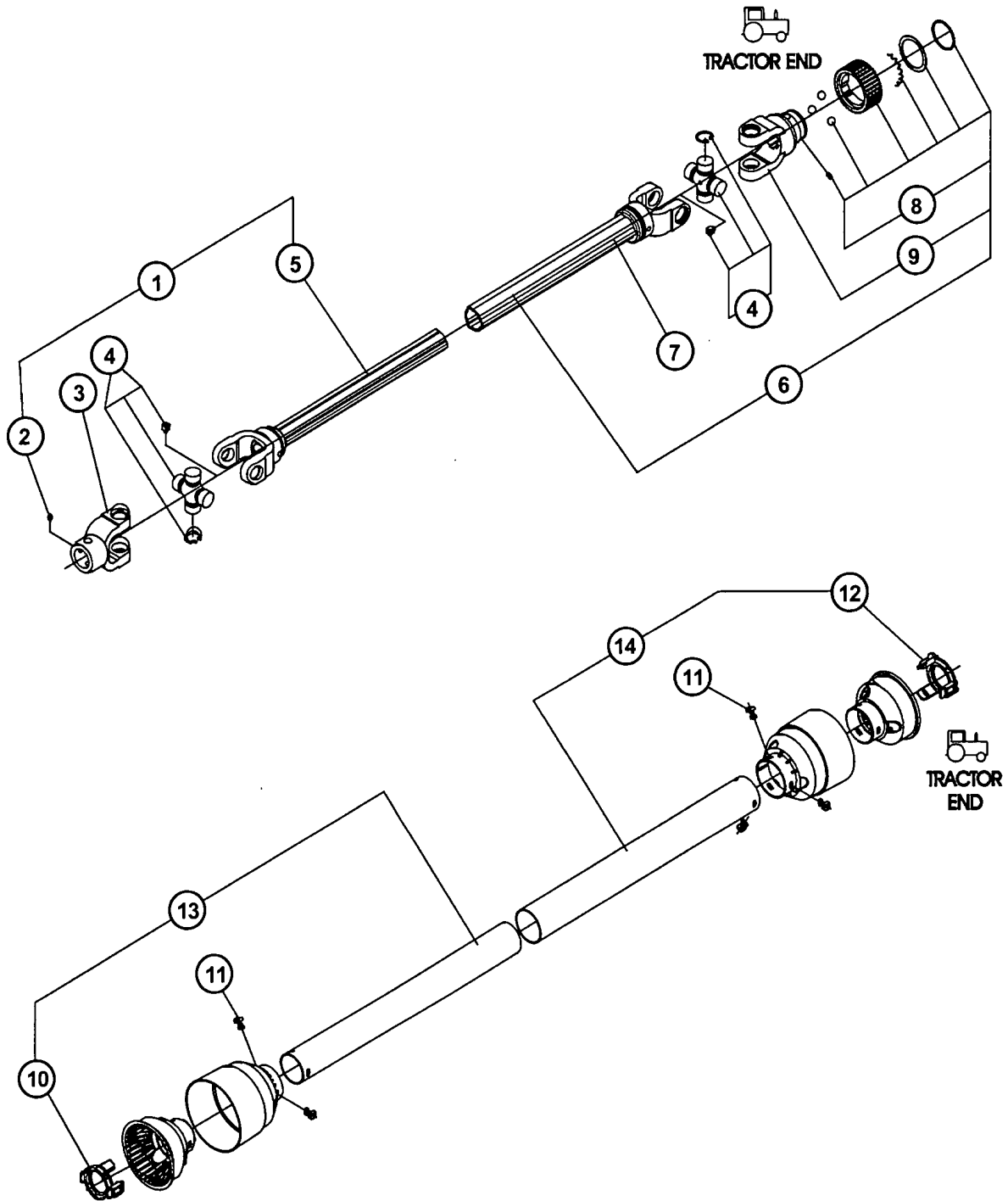

DRIVELINE ASSEMBLY S/N 16873 -BELOW Rev 10-04

| ITEM | PART NO. | QTY. | DESCRIPTION |
|------|------------------|------|----------------------------|
| | 00759161B | - | DRIVELINE ASSEMBLY |
| 1 | 00768296 | 1 | INNER SHAFT & SHIELD ASSY |
| 2 | 001465 | 1 | GREASE FITTING |
| 3 | 00768257 | 1 | SHEAR BOTL YOKE |
| 4 | 00756231 | 2 | CROSS & BEARING KIT |
| 5 | 00768295 | 1 | INNER TUBE ASSEMBLY |
| 6 | 00768294 | 1 | OUTER SHAFT & SHIELD ASSY |
| 7 | 00768293 | 1 | OUTER TUBE ASSEMBLY |
| 8 | 00770391 | 1 | TWIST COLLAR KIT |
| 9 | 00759170 | 1 | YOKE ASSEMBLY |
| 10 | 00764506 | 1 | INNER TUBE BEARING |
| 11 | 00754330 | 6 | LOCKING PIN |
| 12 | 00764507 | 1 | OUTER TUBE BEARING |
| 13 | 00775112 | 1 | INNER HALF SHIELD ASSEMBLY |
| 14 | 00775113 | 1 | OUTER HALF SHIELD ASSEMBLY |

SE4 (Oct-04) S/N 16874 -Current Rev 09-05

DRIVELINE ASSEMBLY S/N 16874 -CURRENT Rev 09-05

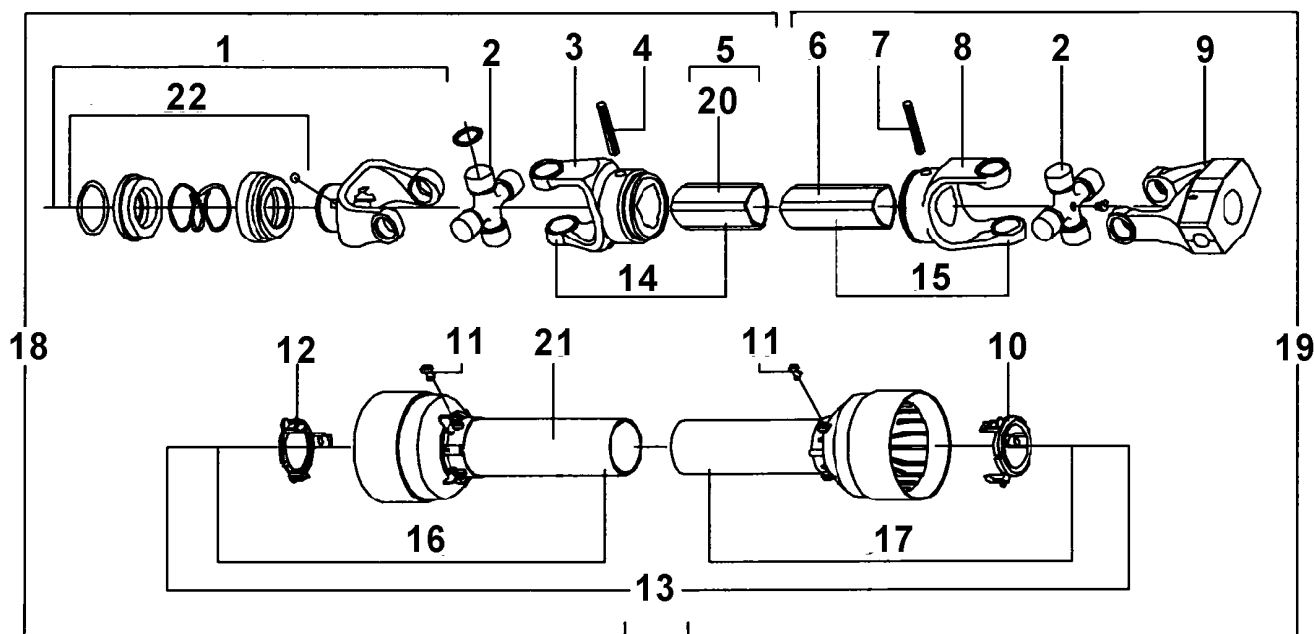

| ITEM | PART NO. | QTY. | DESCRIPTION |
|------|------------------|------|-----------------------------------|
| | 00759161C | - | DRIVELINE |
| 1 | 00764500A | 1 | ASY,YOKE COLLAR - COMPLETE |
| 2 | 00756231 | 2 | CROSS & BEARING KIT SERIES 40 |
| 3 | ----- | 1 | OUTER YOKE |
| 4 | 00759169 | 1 | PIN ROLL 8mm X 60mm |
| 5 | ----- | 1 | OUTER TUBE WITH LABEL |
| 6 | ----- | 1 | INNER TUBE |
| 7 | 00759165 | 1 | PIN ROLL INNER TUBE |
| 8 | ----- | 1 | INNER YOKE |
| 9 | 00777329A | 1 | YOKE, 1-3/8 BORE SP |
| 10 | 00764506 | 1 | COLLAR-INNER-GUARD-RETAINER |
| 11 | 00754330 | 6 | BOLT, NYLON - SAFETY SHIELD] |
| 12 | 00764507 | 1 | COLLAR-OUTER-GUARD-RETAINER |
| 13 | 00768342 | 1 | SHIELD, ASY, CMLPT |
| 14 | ----- | 1 | FEMALE TUBE YOKE WITH LABEL |
| 15 | ----- | 1 | MALE TUBE YOKE |
| 16 | ----- | 1 | HALF FEMALE GUARD |
| 17 | ----- | 1 | HALF FEMALE GUARD |
| 18 | 00768294 | 1 | SHAFT, ASY, OUTER W/SHIELD |
| 19 | 00768296 | 1 | SHAFT, ASY, INNER W/SHIELD |
| 20 | ----- | 1 | DANGER LABEL FOR OUTER TUBE |
| 21 | ----- | 1 | DANGER LABEL FOR OUTER GUARD TUBE |
| 22 | 00774079 | 1 | KIT,SLIDE COLLAR REPAIR |

FRONT DEFLECTORS ASSEMBLY

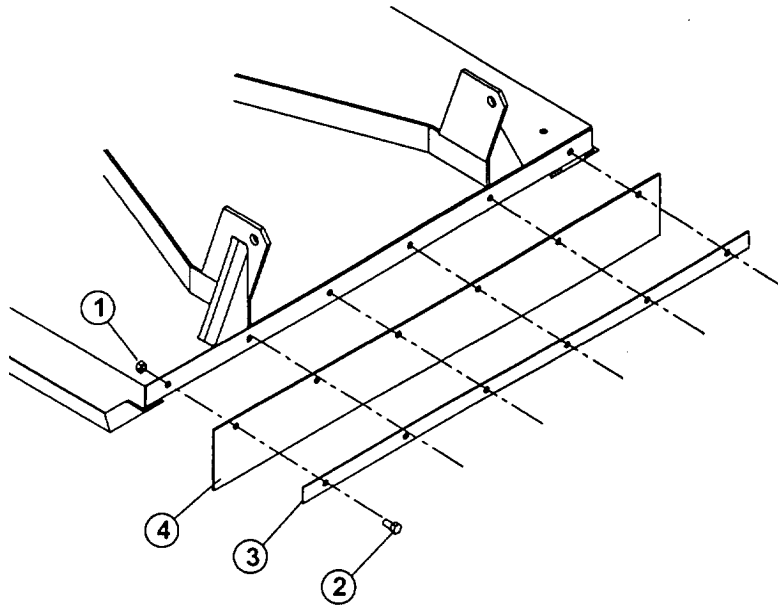

FRONT

| ITEM | PART NO. | QTY. | DESCRIPTION |
|------|-----------------|------|-----------------------------|
| | 00773940 | - | FRONT DEFLECTOR ASSY |
| 1 | 00001800 | 6 | LOCKNUT |
| 2 | 00748823 | 6 | BOLT |
| 3 | 00773944 | 1 | DEFLECTOR STRAP |
| 4 | 00773943 | 1 | DEFLECTOR |

REAR DEFLECTORS ASSEMBLY

REAR

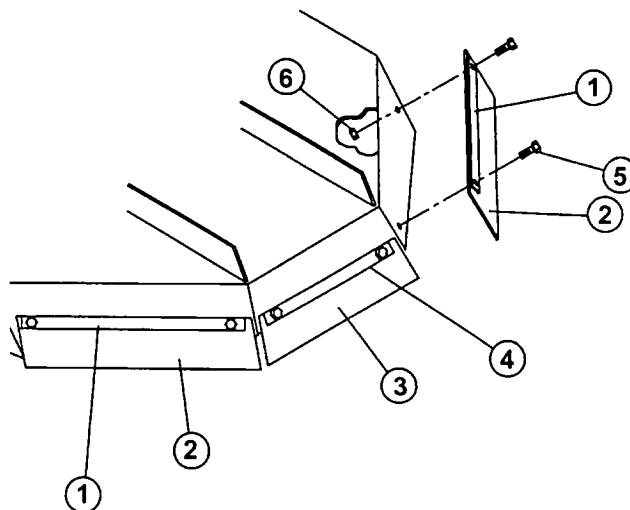

| ITEM | PART NO. | QTY. | DESCRIPTION |
|------|-----------------|------|----------------------------|
| | 00761603 | - | REAR DEFLECTOR ASSY |
| 1 | 00761597 | 2 | SIDE STRAP |
| 2 | 00761596 | 2 | SIDE DEFLECTOR |
| 3 | 00761598 | 1 | CENTER DEFLECTOR |
| 4 | 00761599 | 1 | CENTER STRAP |
| 5 | 7A181310 | 6 | BOLT |
| 6 | 00001800 | 6 | LOCKNUT |

HYDRAULIC RELIEF ASSEMBLY (OPTION)

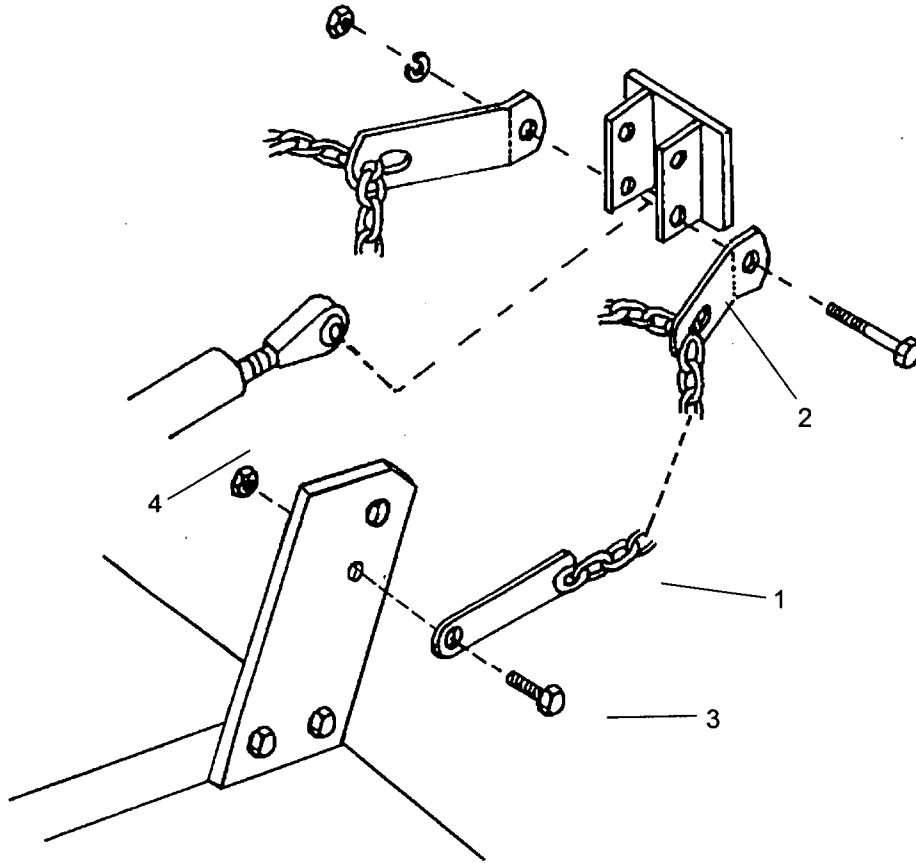

| ITEM | PART NO. | QTY. | DESCRIPTION |
|------|----------|------|----------------|
| 1 | 8709 | 2 | CHAIN ASSEMBLY |
| 2 | 8708 | 2 | BRACKET |
| 3 | 02845500 | 2 | BOLT |
| 4 | 00695100 | 2 | NUT |

OFFSET ADAPTER (OPTION)

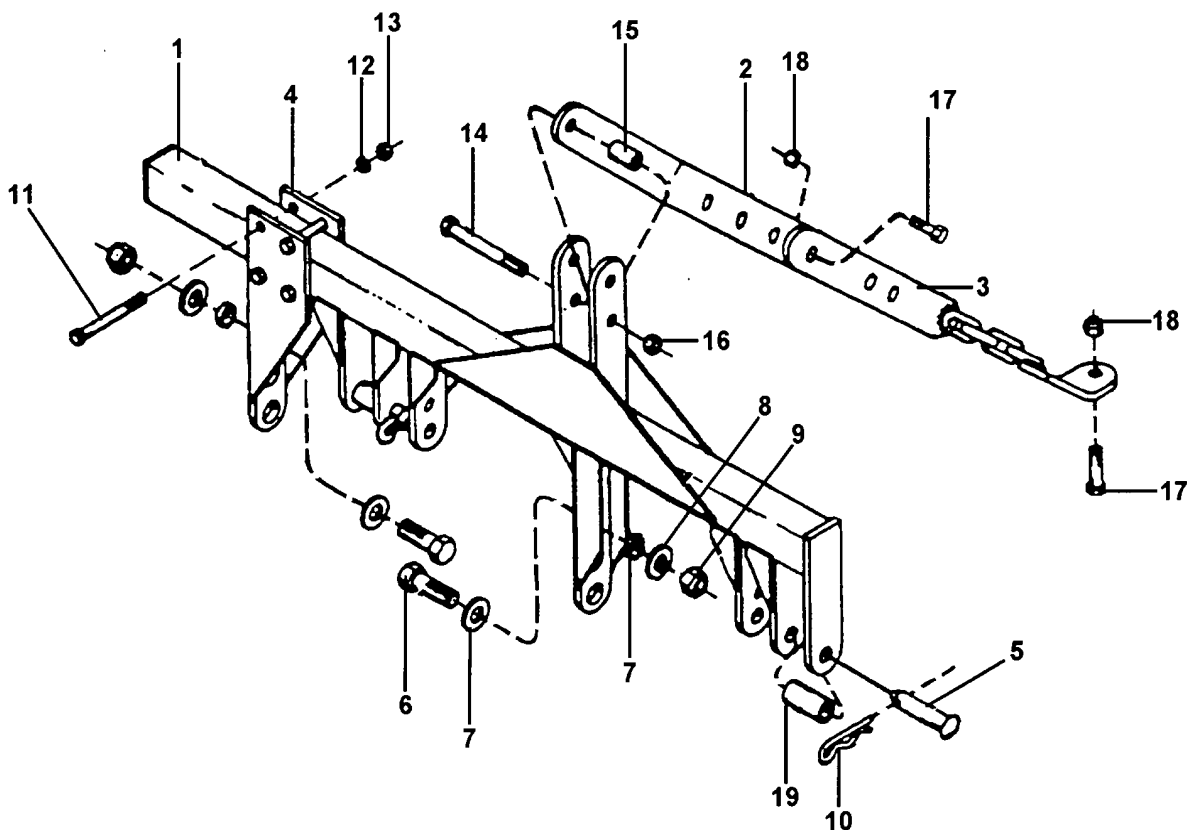

| ITEM | PART NO. | QTY. | DESCRIPTION |
|------|-------------------|------|-----------------------|
| | 0702310000 | - | OFFSET ADAPTER |
| 1 | 0702310100 | 1 | ADAPTER MAINFRAME |
| 2 | 0702310001 | 1 | BRACE BAR |
| 3 | 0702310300 | 1 | BRACE LUG AND CHAIN |
| 4 | 0702310200 | 1 | ADJUSTABLE LIFT LUG |
| 5 | 511027 | 2 | WRIST PIN |
| 6 | 7A14924 | 2 | BOLT |
| 7 | 15B1400 | 4 | WASHER |
| 8 | 423013 | 4 | BUSHING |
| 9 | 5JRC1490 | 2 | LOCKNUT |
| 10 | 3W6 | 2 | RETAING PIN |
| 11 | 02030400 | 4 | BOLT |
| 12 | 00001300 | 4 | LOCKWASHER |
| 13 | 00001200 | 4 | HEX NUT |
| 14 | 7AH5121636 | 1 | BOLT |
| 15 | 595062 | 1 | SPACER |
| 16 | 00748539 | 1 | LOCKNUT |
| 17 | 7AH5101816 | 2 | BOLT |
| 18 | 00749136 | 2 | LOCKNUT |
| 19 | 743013 | 2 | BUSHING |

SAFETY DECAL SHEETS



2

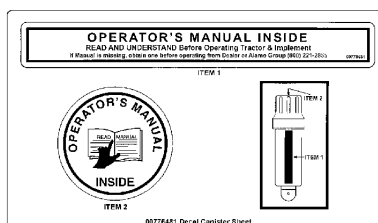

1

| ITEM | PART NO. | QTY. | DESCRIPTION |
|------|----------|------|---|
| 1 | 00776481 | 1 | SHEET, MANUAL CANISTER DECAL |
| 2 | 00773310 | 1 | KIT, DECAL SHEET SE-4 |
| 3 | 2738332 | 2 | DECAL, RED OBLONG REFLECTOR (NOT SHOWN) |

SERVIS-RHINO

LIMITED WARRANTY

1. LIMITED WARRANTIES

- 1.01. Servis-Rhino warrants for one year from the purchase date to the original non-commercial, governmental, or municipal purchaser ("Purchaser") and warrants for six months to the original commercial or industrial purchaser ("Purchaser") that the goods purchased are free from defects in material or workmanship.
- 1.02. Manufacturer will replace for the Purchaser any part or parts found, upon examination at one of its factories, to be defective under normal use and service due to defects in material or workmanship.
- 1.03. This limited warranty does not apply to any part of the goods which has been subjected to improper or abnormal use, negligence, alteration, modification, or accident, damaged due to lack of maintenance or use of wrong fuel, oil, or lubricants, or which has served its normal life. This limited warranty does not apply to any part of any internal combustion engine, or expendable items such as blades, shields, guards, or pneumatic tires except as specifically found in your Operator's Manual.
- 1.04. Except as provided herein, no employee, agent, Dealer, or other person is authorized to give any warranties of any nature on behalf of Manufacturer.

2. REMEDIES AND PROCEDURES.

- 2.01. This limited warranty is not effective unless the Purchaser returns the Registration and Warranty Form to Manufacturer within 30 days of purchase.
- 2.02. Purchaser claims must be made in writing to the Authorized Dealer ("Dealer") from whom Purchaser purchased the goods or an approved Authorized Dealer ("Dealer") within 30 days after Purchaser learns of the facts on which the claim is based.
- 2.03. Purchaser is responsible for returning the goods in question to the Dealer.
- 2.04. If after examining the goods and/or parts in question, Manufacturer finds them to be defective under normal use and service due to defects in material or workmanship, Manufacturer will:
 - (a) Repair or replace the defective goods or part(s) or
 - (b) Reimburse Purchaser for the cost of the part(s) and reasonable labor charges (as determined by Manufacturer) if Purchaser paid for the repair and/or replacement prior to the final determination of applicability of the warranty by Manufacturer.The choice of remedy shall belong to Manufacturer.
- 2.05. Purchaser is responsible for any labor charges exceeding a reasonable amount as determined by Manufacturer and for returning the goods to the Dealer, whether or not the claim is approved. Purchaser is responsible for the transportation cost for the goods or part(s) from the Dealer to the designated factory.

3. LIMITATION OF LIABILITY.

- 3.01. MANUFACTURER DISCLAIMS ANY EXPRESS (EXCEPT AS SET FORTH HEREIN) AND IMPLIED WARRANTIES WITH RESPECT TO THE GOODS INCLUDING, BUT NOT LIMITED TO, MERCHANTABILITY AND FITNESS FOR A PARTICULAR PURPOSE.
- 3.02. MANUFACTURER MAKES NO WARRANTY AS TO THE DESIGN, CAPABILITY, CAPACITY, OR SUITABILITY FOR USE OF THE GOODS.
- 3.03. EXCEPT AS PROVIDED HEREIN, MANUFACTURER SHALL HAVE NO LIABILITY OR RESPONSIBILITY TO PURCHASER OR ANY OTHER PERSON OR ENTITY WITH RESPECT TO ANY LIABILITY, LOSS, OR DAMAGE CAUSED OR ALLEGED TO BE CAUSED DIRECTLY OR INDIRECTLY BY THE GOODS INCLUDING, BUT NOT LIMITED TO, ANY INDIRECT, SPECIAL, CONSEQUENTIAL, OR INCIDENTAL DAMAGES RESULTING FROM THE USE OR OPERATION OF THE GOODS OR ANY BREACH OF THIS WARRANTY. NOT WITHSTANDING THE ABOVE LIMITATIONS AND WARRANTIES, MANUFACTURER'S LIABILITY HEREUNDER FOR DAMAGES INCURRED BY PURCHASER OR OTHERS SHALL NOT EXCEED THE PRICE OF THE GOODS.
- 3.04. NO ACTION ARISING OUT OF ANY CLAIMED BREACH OF THIS WARRANTY OR TRANSACTIONS UNDER THIS WARRANTY MAY BE BROUGHT MORE THAN TWO (2) YEARS AFTER THE CAUSE OF ACTION HAS OCCURRED.

4. MISCELLANEOUS.

- 4.01. Proper Venue for any lawsuits arising from or related to this limited warranty shall be only in Guadalupe County, Texas.
- 4.02. Manufacturer may waive compliance with any of the terms of this limited warranty, but no waiver of any terms shall be deemed to be a waiver of any other term.
- 4.03. If any provision of this limited warranty shall violate any applicable law and is held to be unenforceable, then the invalidity of such provision shall not invalidate any other provisions herein.
- 4.04. Applicable law may provide rights and benefits to purchaser in addition to those provided herein.

KEEP FOR YOUR RECORDS

ATTENTION: Purchaser should fill in the blanks below for his reference when buying repair parts and/or for proper machine identification when applying for warranty.

Servis-Rhino Implement Model _____ Serial Number _____

Date Purchased _____ Dealer _____

ATTENTION:
READ YOUR OPERATOR'S MANUAL

RHINO[®]
1020 S. Sangamon Ave.
Gibson City, IL 60936
800-446-5158
Email: parts@servis-rhino.com





TO THE OWNER/OPERATOR/DEALER

To keep your implement running efficiently and safely, read your manual thoroughly and follow these directions and the Safety Messages in this Manual. The Table of Contents clearly identifies each section where you can easily find the information you need.

The OCCUPATIONAL SAFETY AND HEALTH ACT (1928.51 Subpart C) makes these minimum safety requirements of tractor operators:

REQUIRED OF THE OWNER:

1. Provide a Roll-Over-Protective Structure that meets the requirements of this Standard; and
2. Provide Seatbelts that meet the requirements of this paragraph of this Standard and SAE J4C; and
3. Ensure that each employee uses such Seatbelt while the tractor is moving; and
4. Ensure that each employee tightens the Seatbelt sufficiently to confine the employee to the protected area provided by the ROPS.

REQUIRED OF THE OPERATOR

1. Securely fasten seatbelt if the tractor has a ROPS.
2. Where possible, avoid operating the tractor near ditches, embankments, and holes.
3. Reduce speed when turning, crossing slopes, and on rough, slick, or muddy surfaces.
4. Stay off slopes too steep for safe operation.
5. Watch where you are going - especially at row ends, on roads, and around trees.
6. Do not permit others to ride.
7. Operate the tractor smoothly - no jerky turns, starts, or stops.
8. Hitch only to the drawbar and hitch points recommended by the tractor manufacturer.
9. When the tractor is stopped, set brakes securely and use park lock, if available.



Keep children away from danger all day, every day...



Equip tractors with rollover protection (ROPS) and keep all machinery guards in place...



Please work, drive, play and live each day with care and concern for your safety and that of your family and fellow citizens.



Free Manuals Download Website

<http://myh66.com>

<http://usermanuals.us>

<http://www.somanuals.com>

<http://www.4manuals.cc>

<http://www.manual-lib.com>

<http://www.404manual.com>

<http://www.luxmanual.com>

<http://aubethermostatmanual.com>

Golf course search by state

<http://golfingnear.com>

Email search by domain

<http://emailbydomain.com>

Auto manuals search

<http://auto.somanuals.com>

TV manuals search

<http://tv.somanuals.com>