

Shark[®]

NV100

Owner's Guide

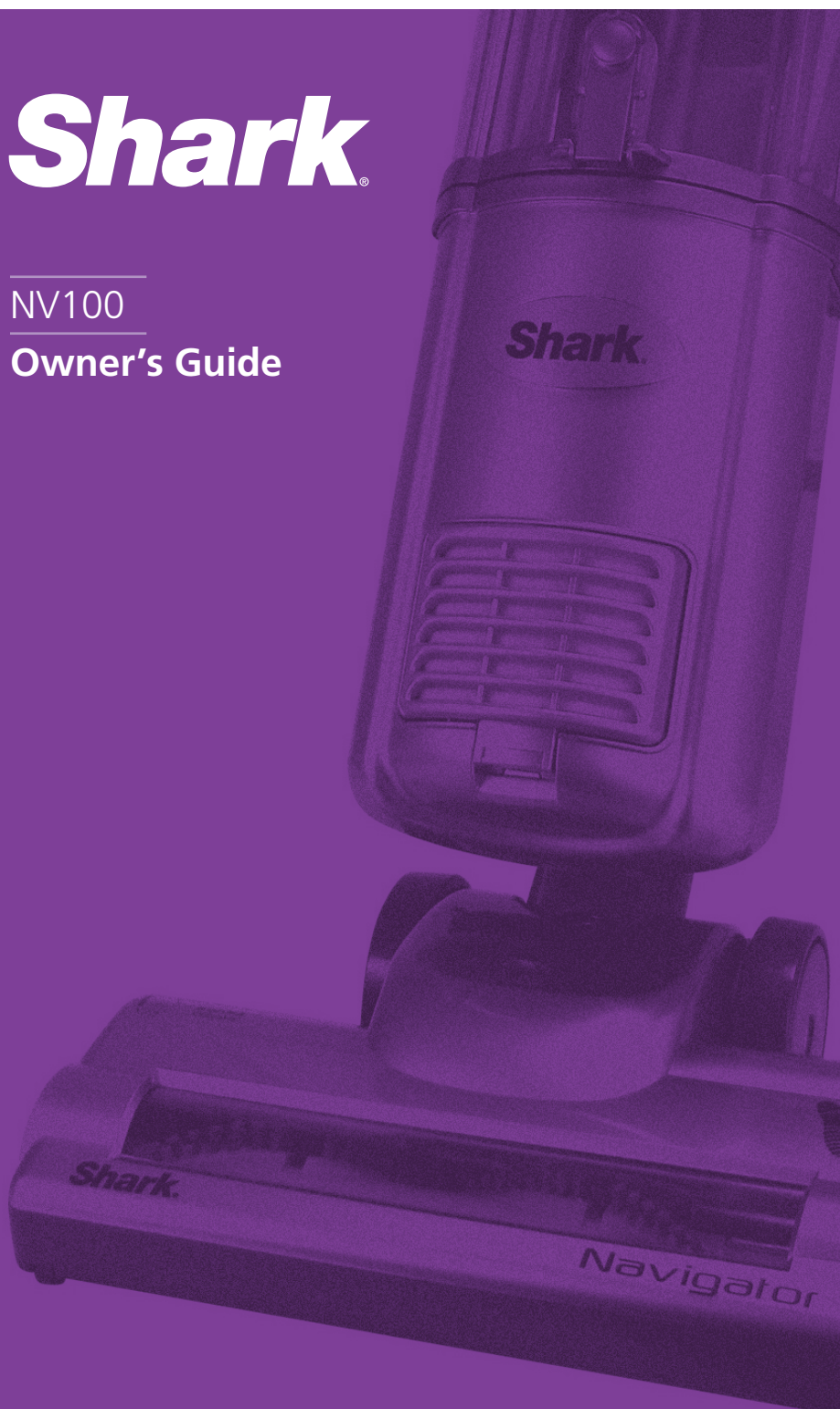

Contents

Thank you for
purchasing
the Shark[®]
Navigator[™]
Vacuum.

| | |
|---------------------------------------|----|
| Important Safety Instructions | 2 |
| Getting Started | 4 |
| Assembly | 4 |
| Using the Vacuum | 6 |
| Emptying the Dust Cup Assembly | 7 |
| Proper Care of Your Vacuum | 8 |
| Troubleshooting | 9 |
| Checking for Blockages | 10 |
| Maintenance | 11 |
| Warranty and Registration | 13 |

This manual covers model:

NV100 26

TECHNICAL SPECIFICATIONS

Voltage: 120V.

Watts: 700W

Amps: 5.83A

Hertz: 60Hz



TOLL FREE: 1-800-798-7398

www.sharkclean.com

IMPORTANT SAFETY INSTRUCTIONS

For Household Use Only

WHEN USING YOUR SHARK® NAVIGATOR™ VACUUM, BASIC SAFETY PRECAUTIONS SHOULD ALWAYS BE FOLLOWED, INCLUDING THE FOLLOWING:

READ ALL INSTRUCTIONS BEFORE USING YOUR SHARK® NAVIGATOR™ VACUUM.

POLARIZED PLUG:

This appliance has a polarized plug (one blade is wider than the other). As a safety feature, this plug will fit into a polarized outlet only one way.

Do not force into the outlet or try to modify the plug to fit.

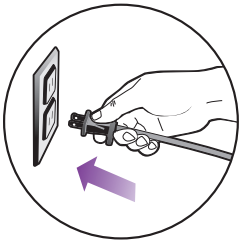

⚠ WARNING:
TO REDUCE THE RISK OF ELECTRIC SHOCK OR INJURY DO NOT USE OUTDOORS OR ON WET SURFACES.

GENERAL ELECTRICAL SAFETY:

1. Unplug from electrical outlet when not in use and before servicing.
2. **DO NOT** use vacuum with a damaged cord or plug.
3. **DO NOT** pull or carry vacuum by the cord.
4. **DO NOT** unplug by pulling on cord; to unplug, grasp the plug, not the cord.
5. **DO NOT** handle plug or vacuum cleaner with wet hands.
6. **DO NOT** run the vacuum over the power cord.
7. **DO NOT** close a door on the cord.
8. **DO NOT** pull cord around sharp edges or corners.
9. **DO NOT** leave appliance when plugged in.
10. Keep power cord away from heated surfaces.
11. Turn off all controls before plugging or unplugging vacuum cleaner.

GENERAL USE:

12. Use only as described in this manual.
13. **DO NOT** put any objects into openings.
14. Keep your work area well lit.
15. Keep the vacuum moving over the carpet surface at all times to avoid damaging the carpet fibers.
16. **DO NOT** place vacuum on unstable surfaces such as chairs or tables.
17. **DO NOT** allow young children to operate the vacuum or use as a toy.
18. Close attention is necessary when used by or near children.
19. **DO NOT** use vacuum cleaner if the appliance is not working as it should, has a damaged plug or cord, if the unit has been dropped, damaged, left outdoors or submerged in water. Return to EURO-PRO Operating LLC for examination, repair or adjustment.

GENERAL CLEANING:

20. **DO NOT** run the vacuum over large-sized objects.
21. **DO NOT** pick up hard or sharp objects such as glass, nails, screws or coins that could damage the vacuum cleaner.
22. **DO NOT** pick up smoking or burning objects such as hot coals, cigarette butts or matches.
23. **DO NOT** pick up flammable or combustible materials such as lighter fluid, gasoline, kerosene or use in areas where they may be present.
24. **DO NOT** pick up toxic solutions such as chlorine bleach, ammonia or drain cleaner.
25. **DO NOT** use in an enclosed space where vapors are present from paint, paint thinner, moth-proofing substances, flammable dust or other explosive or toxic materials.
26. **DO NOT** vacuum up any liquids.
27. **DO NOT** immerse vacuum cleaner in water or other liquids.
28. **DO NOT** use outdoors or on wet surfaces; use only on dry surfaces.
29. Use extra care when cleaning on stairs.
30. Before turning on the vacuum:
 - Make sure that dust cup, and all filters are in place after routine maintenance.
 - Make sure that all components and filters are thoroughly dry after routine cleaning.
 - Only use filters and accessories provided by EURO-PRO Operating LLC [Failure to do so will void the warranty]

HOSE ATTACHMENTS:

31. **DO NOT** put any object into openings. Do not use with any opening blocked. Keep free of lint, hair and anything that may reduce airflow.
32. **DO NOT** use if air flow is restricted; if the air paths, the hose or the extension tube become blocked, turn the vacuum cleaner off. Remove all obstructions before you turn on the unit again.
33. Keep the end of the hose, wands and other openings away from face, body and loose clothing.
34. Keep rotating brush and suction openings away from hair, face, fingers, uncovered feet or loose clothing.
35. Only use manufacturer's recommended attachments.

SAVE THESE INSTRUCTIONS

Getting Started

ASSEMBLY

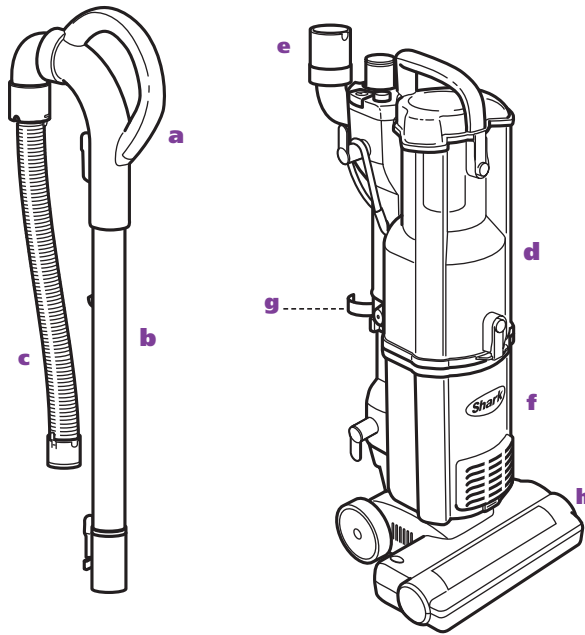

FIRST THING'S FIRST, YOU NEED TO KNOW WHAT'S IN THE BOX YOU JUST OPENED:

- a** Handle
- b** Extension Wand
- c** Stretch Hose
- d** Dust Cup
- e** Hose Connector
- f** Vacuum Body
- g** Accessory Holder
- h** Power Nozzle

Optional tools are available for sale for any NV100 model. To order additional parts or accessories go to www.sharkclean.com.

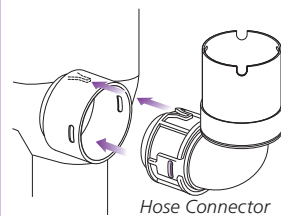

Fig. 1

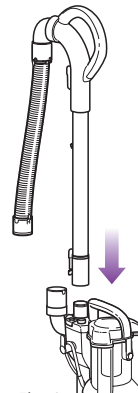

Fig. 2

YOUR SHARK® NAVIGATOR™ IS EASY TO ASSEMBLE:

- 1** Place your vacuum body upright on a level surface.
- 2** Insert the hose connector into the opening on the back of the vacuum body. **(Fig. 1)**
NOTE: Once the hose connector has been inserted, it cannot be removed.
- 3** Insert the handle with the extension wand into the top of the vacuum until secure. **(Fig. 2)**

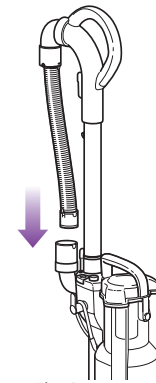

Fig. 3

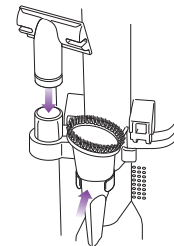

Fig. 4

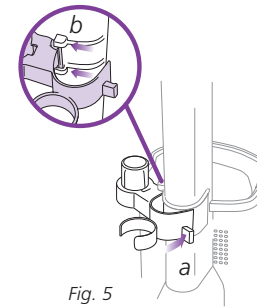

Fig. 5

⚡ Not all accessories are available on all models.

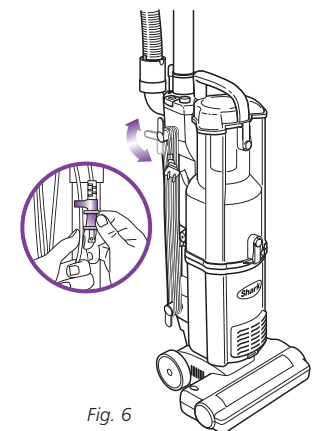

Fig. 6

- 4** Insert the stretch hose into the hose connector on the back of the unit. Make sure that it snaps in place. **(Fig. 3)**
- 5** Store your on-board tools onto the accessory holder located on the back of the unit. **(Fig. 4)**
NOTE: The accessory holder is removable. In order to remove or attach the accessory holder, you must remove the dust cup first. To remove the accessory holder, just hold the tab **(a)**, rotate left and pull out. To replace, align the pins into the hinges **(b)** on the vacuum. Rotate it fully to secure. **(Fig. 5)**
- 6** When storing your vacuum, wind the power cord around the two cord holders and secure with cord clip. **(Fig. 6)**
- 7** There is a Quick Cord Release on the top cord holder. Simply turn to the left or right to release the power cord. To store the unit, the cord holder should be in the upright position.
⚠ IMPORTANT: For suction to reach the motorized floor brush, the extension wand and stretch hose must be attached securely on the vacuum body.
- 8 TO CARRY THE VACUUM:**
With the unit in the standing position, lift by the Dust Cup Handle (carry handle).
⚠ CAUTION: When lifting or carrying, **DO NOT** press Dust Cup release button.

Using the Vacuum

⚠ For suction to reach the power nozzle, the extension wand and stretch hose must be attached securely on the vacuum body.

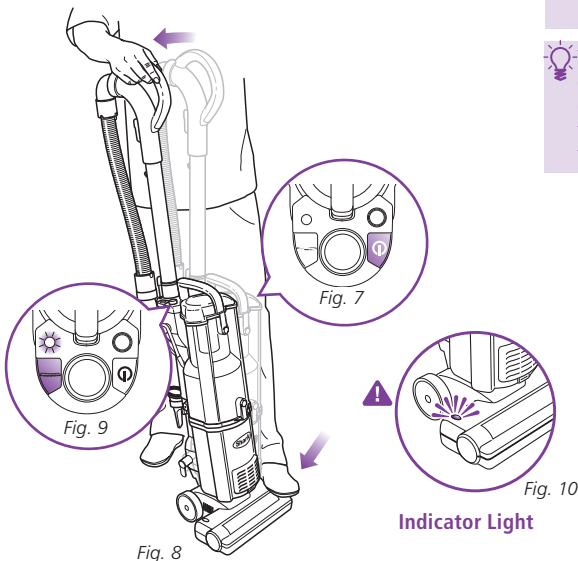

Fig. 8

Your Shark® Navigator™ can be used to clean all surface types.

- 1 Plug in the vacuum.
- 2 Push the Power button (⏻). (Fig. 7)
- 3 Place your foot on the power nozzle and pull the handle back towards you. (Fig. 8)

NOTE: This vacuum has a separate brushroll button (↔) on the top of the vacuum. (Fig. 9)

4 CLEAN CARPETS:

Engage the brushroll by pushing the brushroll button (↔) to the "ON" position. The brushroll light will turn green. (Fig. 9)

⚠ **DO NOT** pull vacuum cleaner around by the hose.

DO NOT over-extend the hose. Always hold the vacuum so that it does not tip over.

💡 The height of your power nozzle has been optimized for easy pushing and superior cleaning on all floor types. There is no need to make any height adjustments as you transition to different floor & carpet types.

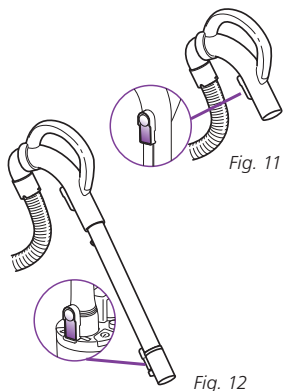

Fig. 12

⚠ **IMPORTANT:** To protect your carpets, the brushroll will only turn on when you have pulled the handle back towards you and released the power nozzle.

⚠ **IMPORTANT:** The brushroll indicator light on the power nozzle will illuminate solid red if there is a blockage. (Fig. 10) This feature is designed to protect your Lifetime Belt that powers your brushroll. See **Checking for Blockages on page 11.**

5 CLEAN BARE FLOORS:

For cleaning bare floors or to clean with the hose, push the brushroll button (↔) to the "OFF" position for suction only. The brushroll light will turn off. The brushroll will not spin in this mode.

6 CLEAN ABOVE-FLOORS WITH HOSE:

You can attach the accessories onto the handle or onto the extension wand for a longer reach.

- a Stand the vacuum into upright position.
- b To remove the handle only, press the handle release button. (Fig. 11)
- c To remove the handle with the extension wand, press the extension wand release button on the back of the vacuum. (Fig. 12)
- d Push the selected tool into the end of the handle or handle with extension wand for longer reach and begin cleaning.

To order additional parts and accessories, go to www.sharkclean.com.

Emptying the Dust Cup Assembly

💡 For best results empty the Dust Cup Assembly after each use; or as needed during prolonged usage; or when it reaches the **MAX** fill line.

DO NOT OVERFILL.

Turn vacuum off before emptying.

Dust cup Release Button

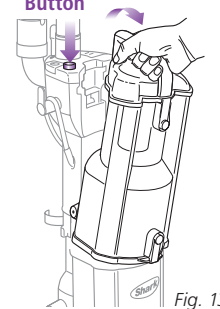

Fig. 13

Fig. 15

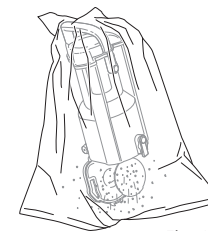

Fig. 16



Fig. 14

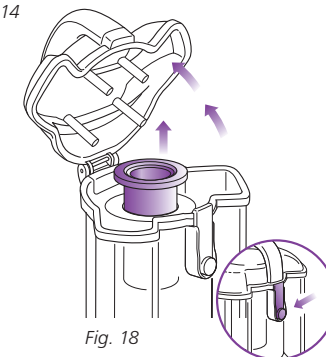

Fig. 18

Fig. 17

TO EMPTY THE DUST CUP ASSEMBLY:

- 1 Press the Dust Cup release button and remove the dust cup from the vacuum. (Fig. 13)
 - 2 Grip carry handle and press the bottom Dust Cup Door release button. (Fig. 14)
 - 3 **Option A:** for Quick Empty: Insert Dust Cup Assembly deep inside trash receptacle to contain dust and debris. (Fig. 15)
Press the bottom Dust Cup Door release button; tap container gently to dislodge and release dust and debris.
Close the bottom door until it snaps in place.
- ⚠ **Important:** If the Dust Cup Door does not swing open freely after pressing the release button, push the door open using the bottom door tabs.

- 4 **Option B:** For Allergy Sufferers: Wrap a trash bag around the Dust Cup Assembly leaving space at the bottom for the door to swing open. (Fig. 16)

Locate the Dust Cup Door release button within the trash bag and press to release as you shake the dust cup to empty dust and debris.

Close the bottom door until it snaps in place.

- ⚠ **Note:** Option B can also be performed outside of the home to further minimize releasing dust back into the air. Carry just the Dust Cup Assembly and trash bag outside.

- ⚠ **Note:** It may become necessary to occasionally clean the metal screen inside the dust cup. To clean, press the top dust cup release button (Fig. 17), pull out the metal screen and remove any excess dirt. Then replace the metal screen inside the dust cup and close the top lid. (Fig. 18)

Proper Care of Your Shark® Upright Vacuum

| COMPONENT | MAINTENANCE SCHEDULE |
|-------------------------|--|
| 1 Dust Cup | Empty each time you vacuum. |
| 2 Pre-Motor Foam Filter | Rinse and air dry every 3 months under normal use. |
| 3 Pre-Motor Felt Filter | Rinse and air dry every 3 months under normal use. |
| 4 Post-Motor Filter | Clean once every 12 months under normal use. |

! DO NOT put the filters in the washing machine or dishwasher.

NOTE: The material in the filter will discolor over time. This is **NORMAL** and will not affect the performance of the filter.

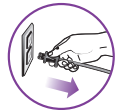

! CAUTION: Unplug the vacuum while cleaning filters; failure to do so might result in electric shock.

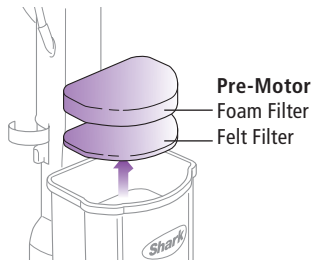

Fig. 18

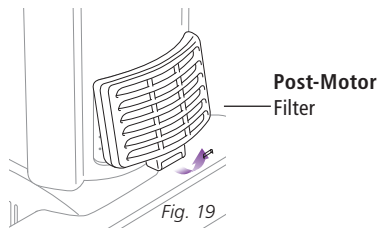

Fig. 19

CLEANING THE PRE-MOTOR FILTERS

- 1 Remove the dust cup.
- 2 Pull the 2 filters out from the top of the motor base. **(Fig. 18)**
- 3 Rinse the filters thoroughly in lukewarm water until the water runs clear.
- 4 Squeeze out excess water and let air-dry for at least 24 hours before replacing. Do not use a hair dryer or other heating methods to dry.
- 5 Place the felt filter in first, then the foam filter.
- 6 Replace the dust cup.

CLEANING THE POST-MOTOR FILTER

- 1 Remove the filter cover from the front of the vacuum by pulling up on the tab and pulling the cover away from the vacuum. **(Fig. 19)**
- 2 Remove the filter from the frame and wash the filter under the tap using lukewarm water.
- 4 Allow the filter to air dry for 24 hours. Do not use a hair dryer or other heating methods to dry.
- 5 Once the filter is dry, replace it back into the vacuum.
- 6 Replace the cover by inserting the two tabs into the holes at the top and then swinging the cover down until it clicks into place.

NOTE: Filters may appear dirty but frequent cleaning of these is not necessary. See maintenance schedule above.

Troubleshooting



WARNING:

To reduce the risk of electric shock, the power cord must be disconnected before performing maintenance/troubleshooting checks.

| PROBLEM | POSSIBLE REASONS & SOLUTIONS |
|--|---|
| Vacuum will not run. | <p>Check to see if the vacuum is plugged in properly.</p> <p>Check the circuit breaker/fuse.</p> <p>Check the On/Off button.</p> |
| Vacuum is not picking up dirt. | <p>Check filters to see if they need cleaning. Follow instructions for rinsing and drying the filters before re-inserting back into the vacuum. (See "Maintenance" sections for instructions.)</p> <p>Dust cup may be full; empty dust cup.</p> <p>Check hose and hose connections for blockages; clear blockages if required.</p> <p>If dust cup is empty, and attachment inlets are clear, check for other blockages. (See "Checking for Blockages" for instructions.)</p> |
| Airflow is restricted. No suction or light suction. | <p>Check filters to see if they need cleaning. Follow instructions for rinsing and drying the filters before re-inserting back into the vacuum. (See "Maintenance" sections for instructions.)</p> <p>Dust cup may be full; empty dust cup.</p> <p>Check hose, hose connections, nozzles and accessories for blockages; clear blockages if required.</p> <p>If dust cup is empty, and attachment inlets are clear, check for other blockages. (See "Checking for Blockages" for instructions.)</p> |
| Bush roll does not turn on. | <p>Press the brushroll button (↔) to the "ON" position. The brushroll light near this button will illuminate green when "ON".</p> <p>Place your foot on the floor brush and pull the handle back to engage the brushroll.</p> <p>If the red light on the power nozzle is illuminated, see the section on Checking for Blockages.</p> |
| Vacuum turns off on its own. | <p>This vacuum cleaner is equipped with a motor protective thermostat. If for some reason your vacuum overheats, the thermostat will automatically turn the unit off. Should this occur, perform the following steps to restart the motor thermostat:</p> <ol style="list-style-type: none"> 1. Press the power button (⏻) to the (Off) position. 2. Unplug the vacuum. 3. Empty the dust cup and clean filters. (See "Maintenance" sections for instructions.) 4. Check for blockages in hose, accessories and inlet openings. (See "Checking for Blockages" for instructions.) 5. Allow the unit to cool for a minimum of 45 minutes. 6. Plug in the vacuum. 7. Press the power button (⏻) to the (On) position to restart the vacuum. <p>Note: If vacuum still does not start, contact Customer Service at: 1-800-798-7398.</p> |

To purchase replacement parts, please visit our website: www.sharkclean.com.

Checking for Blockages

Blockages may cause your vacuum to overheat and shut down. If this occurs, clear the blockages, then follow the instructions for **Resetting the Motor Thermostat** on page 11.

IMPORTANT: Never insert sharp objects into any opening to clear an obstruction. Damages caused while clearing or attempting to clear blockages are not covered under your product's limited warranty.

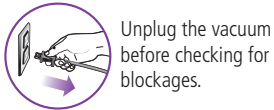

Unplug the vacuum before checking for blockages.

Reassemble all parts securely before operating vacuum.

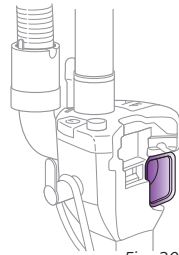
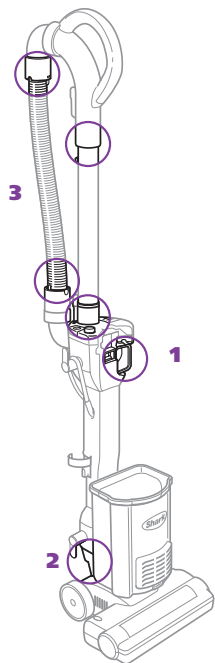

Fig. 20

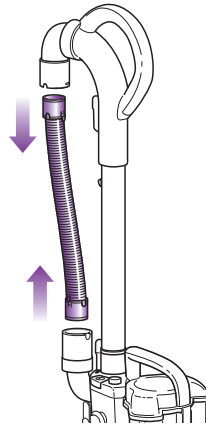

Fig. 22

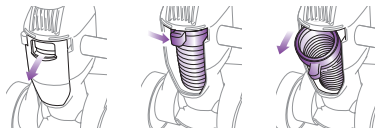

Fig. 21

1 DUST CUP AIR DUCT:

Stand vacuum upright.

Remove Dust Cup Assembly and empty Dust Cup if necessary.

Check Air Duct behind Dust Cup for clogs; clear before replacing Dust Cup Assembly. (Fig. 20)

2 HOSE INTAKE OPENING:

Hold the top of the hose access door and pull firmly to remove. Slide the knob to the center and pull out the hose. (Fig. 21)

Remove any obstructions and push the hose back in.

Slide the knob to the left and snap the hose access door shut.

3 HOSE:

Disconnect the Stretch Hose by gently pressing the tabs together and pulling away from the hose connector.

Remove hose from both the unit and handle ends. (Fig. 22)

Inspect the length of the hose and remove any obstructions.

Maintenance

Resetting the Motor Thermostat

Your Shark® Navigator™ is equipped with a protective Motor Thermostat. If the motor should overheat, the thermostat shuts off the power.

TO RESET THE MOTOR THERMOSTAT:

Press the Power Button (⏻) to turn the unit "Off".

Unplug the vacuum.

Check for clogged hose or filter; unclog hose and replace filter. Refer to **Checking for Blockages** on page 11.

Wait 45 minutes for vacuum to cool; then plug in the vacuum.

Press the Power Switch (⏻) to start the vacuum.

NOTE: If vacuum still does not start, contact Customer Service at: 1-800-798-7398.

Get even more cleaning from your Shark® Navigator™ by checking out our cleaning accessories assortment at www.sharkclean.com.

Bookmark the page and check back often to take advantage of the latest products, promotions and prices!



ADDITIONAL ACCESSORIES:

CREVICE TOOL

Reach deep into narrow spaces and clean between cushions, under radiators and baseboards and in hard to reach crevices and corners.

MULTI-TOOL

This unique tool combines a dusting brush and a crevice tool into one.

PET/UPHOLSTERY TOOL

This tool will remove hair from upholstery and stairs.

NOTE: Some accessories may be included with your purchase.

To order Additional Parts & Accessories go to www.sharkclean.com.

| PART | PART NO. |
|---------------------|----------|
| Stretch Hose | 126FFJ |
| Multi-Tool | 127FFJ |
| Foam & Felt Filter | XFL100 |
| Extension Wand | 1116-FC |
| 24" Crevice Tool | 122FFJ |
| 11" Crevice Tool | 129FFJ |
| Pet/Upholstery Tool | 128FFJ |

Euro-Pro Three-Year (3) Limited Warranty

EURO-PRO Operating LLC warrants this product to be free from defects in material and workmanship for a period of three (3) years from the date of the original purchase, when utilized for normal household use, subject to the following conditions, exclusions and exceptions.

If your appliance fails to operate properly while in use under normal household conditions within the warranty period, return the complete appliance and accessories, freight prepaid to:

- **U.S.: EURO-PRO Operating LLC**
For customer service support call 1-800-798-7398 or visit www.sharkclean.com
- **Canada: EURO-PRO Operating LLC**
4400 Bois Franc, St. Laurent, Québec H4S 1A7

If the appliance is found to be defective in material or workmanship, **EURO-PRO Operating LLC** will repair or replace it free of charge. Proof of purchase date and \$16.99 to cover the cost of return shipping and handling must be included.*

Non-durable parts including, without limitation, filters, brushes and electrical parts which normally require replacement are specifically excluded from warranty.

The liability of **EURO-PRO Operating LLC** is limited solely to the cost of the repair or replacement of the unit at our option. This warranty does not cover normal wear of parts and does not apply to any unit that has been tampered with or used for commercial purposes. This limited warranty does not cover damage caused by misuse, abuse, negligent handling or damage due to faulty packaging or mishandling in transit. This warranty does not cover damage or defects caused by or resulting from damages from shipping or repairs, service or alterations to the product or any of its parts, which have been performed by a repair person not authorized by **EURO-PRO Operating LLC**.

This warranty is extended to the original purchaser of the unit and excludes all other legal and/or conventional warranties. The responsibility of **EURO-PRO Operating LLC** if any, is limited to the specific obligations expressly assumed by it under the terms of the limited warranty. In no event is **EURO-PRO Operating LLC** liable for incidental or consequential damages of any nature whatsoever. Some states do not permit the exclusion or limitation of incidental or consequential damages, so the above may not apply to you.

This warranty gives you specific legal rights, and you may also have other rights which vary from state to state or province to province.

***IMPORTANT: Carefully pack item to avoid damage in shipping. Be sure to include proof of purchase date and to attach tag to item before packing with your name, complete address and phone number with a note giving purchase information, model number and what you believe is the problem with item. We recommend you insure the package (as damage in shipping is not covered by your warranty). Mark the outside of your package "ATTENTION CUSTOMER SERVICE". We are constantly striving to improve our products, therefore the specifications contained herein are subject to change without notice.**

Product Registration

Please visit www.sharkclean.com or call **1-800-798-7398** to register your new Shark® product within ten (10) days of purchase. You will be asked to provide the store name, date of purchase and model number along with your name and address.

The registration will enable us to contact you in the unlikely event of a product safety notification. By registering you acknowledge to have read and understood the instructions for use, and warnings set forth in the accompanying instructions.

Euro-Pro Operating LLC
Newton, MA 02459

English: 1-800-798-7398

www.sharkclean.com

Copyright © Euro-Pro Operating LLC 2011

Printed in China

Illustrations may differ from actual product.

NV100.26.E.110317.2

Free Manuals Download Website

<http://myh66.com>

<http://usermanuals.us>

<http://www.somanuals.com>

<http://www.4manuals.cc>

<http://www.manual-lib.com>

<http://www.404manual.com>

<http://www.luxmanual.com>

<http://aubethermostatmanual.com>

Golf course search by state

<http://golfingnear.com>

Email search by domain

<http://emailbydomain.com>

Auto manuals search

<http://auto.somanuals.com>

TV manuals search

<http://tv.somanuals.com>