

MODEL

HT-SB602

SOUND BAR HOME THEATRE SYSTEM

OPERATION MANUAL

Thank you for purchasing this SHARP product. To obtain the best performance from this product, please read this manual carefully. It will guide you in operating your SHARP product.

HT-SB602 Sound Bar Home Theatre system consisting of HT-SB602 (sound bar system) and CP-SW602 (active subwoofer system).

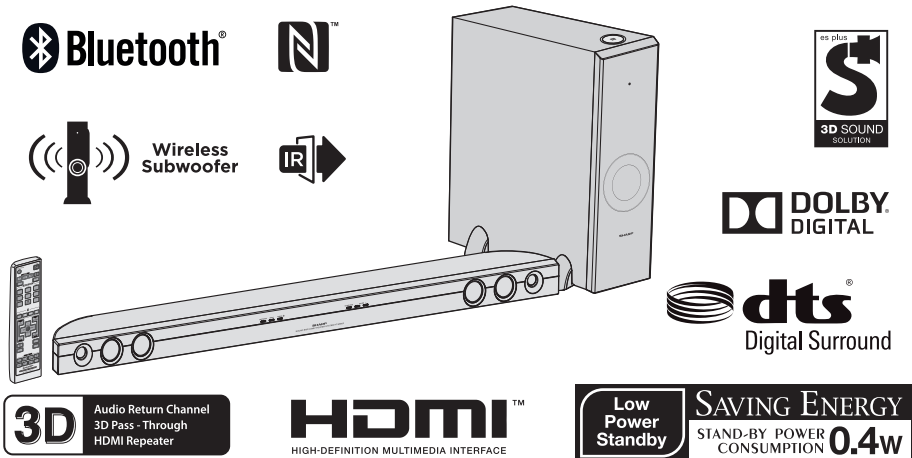

Note:
This product is recommended for 60" or larger flat panel TV (LED, LCD and Plasma).









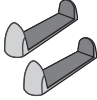
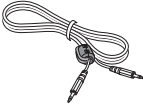

TINSEA467AWZZ

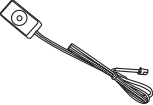
SHARP CORPORATION

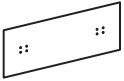
Accessories

The following accessories are included.

				
Remote Control (RRMCGA331AWSA)	Subwoofer Stand x 2	Audio Cable x 1	HDMI Cable x 1	IR Transmitter x 1
				
Wall Mount Angle x 2	Pattern Paper	NFC tag x 1	Velcro tape (hook type) x 1	Velcro tape (loop type) x 2
				
"AAA" size battery (UM-4, R03, HP-16 or similar) x 2				

Special Notes

For DTS patents, see <http://patents.dts.com>. Manufactured under license from DTS Licensing Limited. DTS, the Symbol, & DTS and the Symbol together are registered trademarks, and DTS Digital Surround is a trademark of DTS, Inc. © DTS, Inc. All Rights Reserved.

Manufactured under license from Dolby Laboratories. Dolby and the double-D symbol are trademarks of Dolby Laboratories.

HDMI, the HDMI Logo, and High-Definition Multimedia Interface are trademarks or registered trademarks of HDMI Licensing LLC in the United States and other countries.

Warning:

- When the ON/STANDBY button is set at STANDBY position, mains voltage is still present inside the unit. When the ON/STANDBY button is set at STANDBY position, the unit may be brought into operation by the timer mode or remote control.
- This unit contains no user serviceable parts. Never remove covers unless qualified to do so. This unit contains dangerous voltages, always remove mains plug from the socket before any service operation and when not in use for a long period.
- To prevent fire or shock hazard, do not expose this appliance to dripping or splashing. No objects filled with liquids, such as vases, shall be placed on the apparatus.

The *Bluetooth*® word mark and logos are registered trademarks owned by Bluetooth SIG, Inc. and any use of such marks by SHARP is under license. Other trademarks and trade names are those of their respective owners.

The N Mark is a trademark or registered trademark of NFC Forum, Inc. in the United States and in other countries.

Precautions

General

- Keep your equipment at least 10 cm of free space along the sides, top and back for proper ventilation.

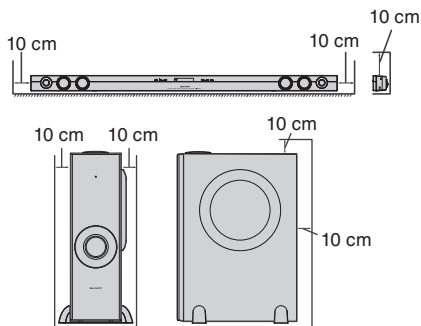

- Use the unit on a firm, level surface free from vibration.
- Keep the unit away from direct sunlight, strong magnetic fields, excessive dust, humidity and electronic/electrical equipment (home computers, facsimiles, etc.) which generate electrical noise.
- Do not place anything on top of the unit.
- Do not expose the unit to moisture, to temperatures higher than 60°C (140°F) or to extremely low temperatures.
- If the unit does not work properly, unplug and plug it in again. Then turn on the unit.
- In case of an electrical storm, unplug the unit for safety.
- Hold the AC power plug by the head when removing it from the wall socket, as pulling the lead can damage internal wires.

- The AC power plug is used as a disconnect device and shall always remain readily operable.
- **Do not remove the outer cover, as this may result in electric shock. Refer internal service to your local SHARP service facility.**
- The ventilation should not be impeded by covering the ventilation openings with items, such as newspapers, tablecloths, curtains, etc.
- No naked flame sources, such as lighted candles, should be placed on the apparatus.
- Attention should be drawn to the environmental aspects of battery disposal.
- This unit should only be used within the range of 5°C - 35°C (41°F - 95°F).
- SHARP is not responsible for damage due to improper use. Refer all servicing to a SHARP authorised service centre.

Warnings:

- The voltage used must be the same as that specified on this unit. Using a higher voltage is dangerous and may result in a fire or other type of accident causing damage. SHARP will not be held responsible for any damage resulting from such usage.
- In case of repairing, please bring the entire system set to the service centre.

Volume control

The sound level at a given volume setting depends on speaker efficiency, location and various other factors. It is advisable to avoid exposure to high volume levels, which occurs whilst turning the unit on with the volume control setting up high, or whilst continually listening at high volumes.

Controls and indicators

Sound Bar Front Panel

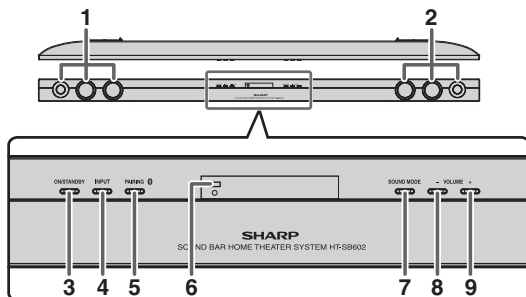

1. Left Channel Speakers
2. Right Channel Speakers
3. On/Standby Button
4. INPUT Button
5. Pairing Button
6. Remote Sensor
7. Sound Mode Button
8. Volume Down Button
9. Volume Up Button

Controls and indicators (continued)

■ Display

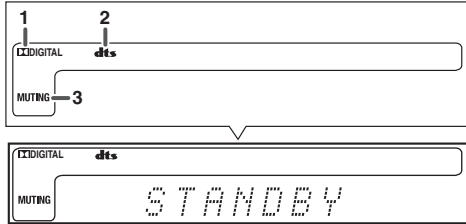

1. Dolby Digital Indicator
2. DTS Indicator
3. Muting Indicator

■ Subwoofer

FRONT VIEW

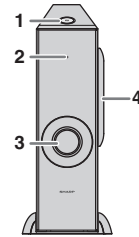

REAR VIEW

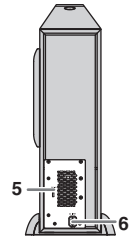

1. NFC detection area
2. Power/Pairing Indicator
3. Bass Reflect Duct
4. Woofer
5. SW LINK (Subwoofer Link) button
6. AC Power Lead

■ Sound Bar Rear Panel

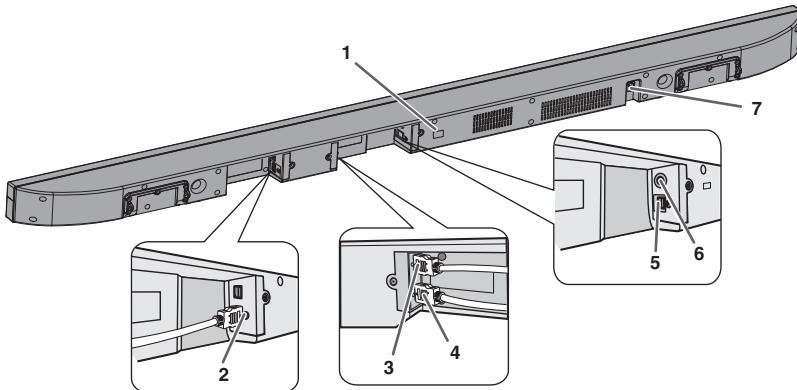

1. IR OUT Terminal
2. HDMI OUT (TV ARC) Socket
3. HDMI IN 1 Socket
4. HDMI IN 2 Socket
5. Optical IN Socket
6. Audio IN Terminal
7. AC Power Lead



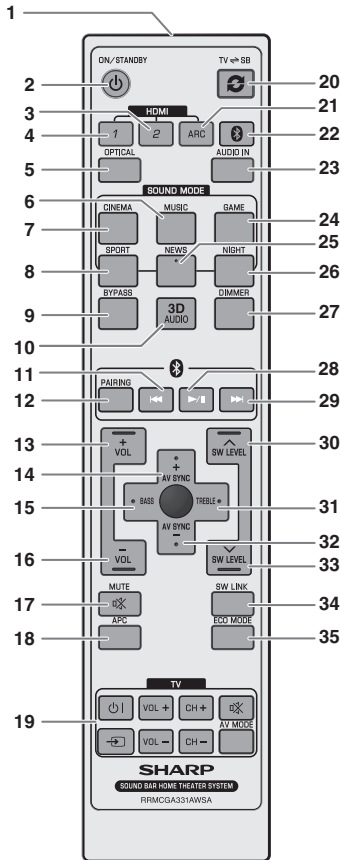





Controls and indicators (continued)



Remote Control

1. Remote Control Transmitter
2. ON/STANDBY Button
3. HDMI 2 Button
4. HDMI 1 Button
5. OPTICAL Button
6. MUSIC (Sound Mode) Button
7. CINEMA (Sound Mode) Button
8. SPORT (Sound Mode) Button
9. BYPASS Button
10. 3D AUDIO Button
11. Bluetooth Skip Down Button
12. Bluetooth Pairing Button
13. Volume Up Button
14. AV SYNC Up Button
15. BASS Button
16. Volume Down Button
17. MUTE Button
18. APC Button
19. TV Operation Button
20. TV \rightleftarrows SB () Speaker Select Button
21. ARC Button
22.  (Bluetooth) Button
23. AUDIO IN Button
24. GAME (Sound Mode) Button
25. NEWS (Sound Mode) Button
26. NIGHT (Sound Mode) Button
27. DIMMER Button
28. Bluetooth Play/Pause Button
29. Bluetooth Skip Up Button
30. SW (Subwoofer) Level Up Button
31. TREBLE Button
32. AV SYNC Down Button
33. SW (Subwoofer) Level Down Button
34. SW (Subwoofer) LINK Button
35. ECO MODE Button

TV Operation Buttons (Only SHARP TV):

On/Standby Button 	Sets the TV power to "ON" or "STANDBY".	Input Select Button (TV) 	Press the button to switch the input source.
Channel Up and Down Buttons  	Switch up/down the TV channels.	Volume Up and Down Buttons  	Turn up/down the TV volume.
AV Mode Button 	Press the button to switch AV mode.	MUTE Button 	Press the button to mute the TV volume.

Note:

Some models of SHARP TV may not be operable.

Sound bar preparation

To mount the sound bar on the wall

Caution:

- Be very careful to prevent the sound bar 3.7 kg from falling when mounting on the wall.
- Before mounting, check the wall strength. (Do not put on the veneer plaster or whitewashed wall. The sound bar may fall.) If unsure, consult a qualified service technician.
- Mounting screws are not supplied. Use appropriate ones.
- Check all wall mount angle screws for looseness.
- Select a good location. If not, accidents may occur or the sound bar may get damaged.
- **SHARP is not responsible for accidents resulting from improper installation.**

■ Driving screws

SHARP designed the sound bar so you may hang them on the wall. Use proper screws (not supplied). See below for size and type.

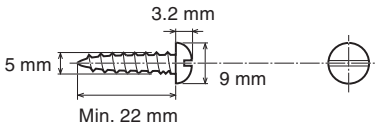

■ Fixing wall mount angle (Horizontal position)

- 1 Fix the pattern paper to the wall in horizontal position as below.

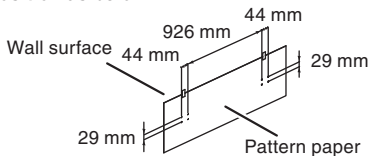

- 2 Make a hole on the wall following the screw point marks on the pattern paper by using a drill.

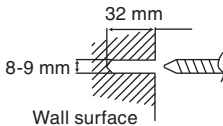

- 3 Fix a wall mount plug (not supplied) into the hole using a hammer, until it is flush with the wall surface.

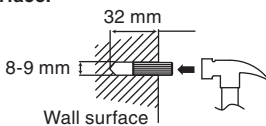

- 4 Screw the wall mount angle to the wall as shown in the illustration. (Total screw is 8 pieces)

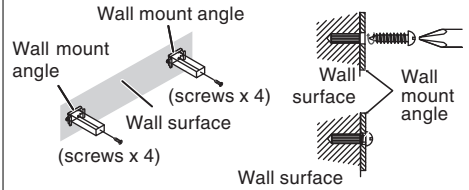

Note:

Make sure all screws are fully tightened. (screws are not supplied)

■ Installing the sound bar

- 1 Align the wall mount slot at the sound bar to the wall mount angle.
- 2 Slot the sound bar into the wall mount angle.
- 3 Fix them securely.

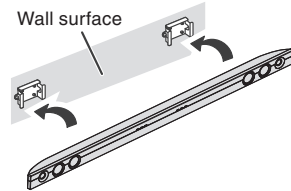

Falling prevention

- Safety wires (not supplied) are useful to prevent the sound bar from falling off.
- 2 persons are required to perform this procedure.

When mounting on the wall

- 1** Loop the safety wires (not supplied) into each hole of the wall mount angle as shown.

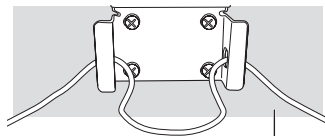

Wall surface

- 2** Loop the safety wires from wall mount angle into each hole of sound bar as shown.

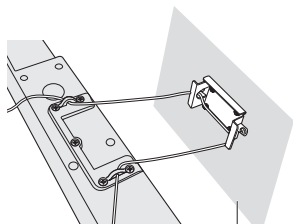

Wall surface

- 3** Align and fix the sound bar to wall mount angle.

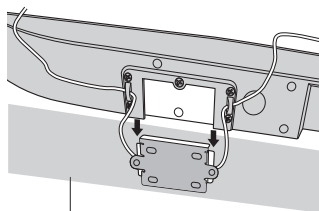

Wall surface

- 4** Tie the safety wires tightly.

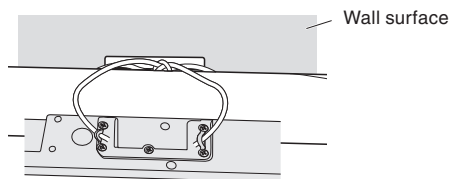

Wall surface

When placing on the shelf/table

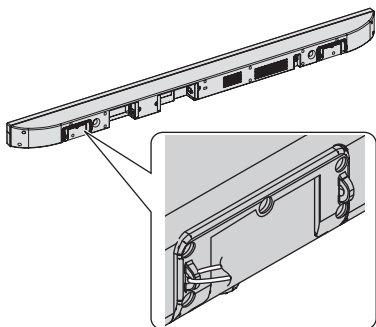

Loop the safety wires (not supplied) into each hole as shown and tie the safety wires to the LCD TV stand.

Placing the system

Installation image:

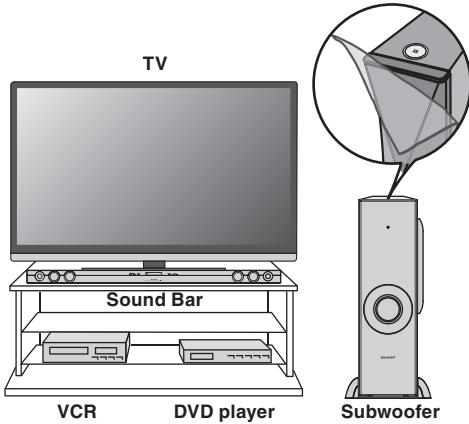

Place the system as shown.

Remove the protective film covering the sound bar and subwoofer before turn on the system.

Notes:

- The front panel of the sound bar is not removable.
- The transmission distance of the wireless signal between the subwoofer and sound bar is about 10 m (32 feet), but may vary depending on your operating environment. If a steel-concrete or metallic wall is between the subwoofer and the sound bar, the system may not operate at all, because the wireless signal cannot penetrate metal.

Caution:

- Do not change the installation direction when the sound bar is turned on.
- Do not stand or sit on the sound bar and subwoofer as you may be injured.
- Do not allow any objects to fall into or to be placed in the bass reflex duct.

Placing the stand

Place the stand as shown.

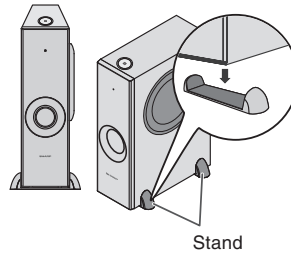

System connections

Make sure to unplug the AC power lead before making any connections.

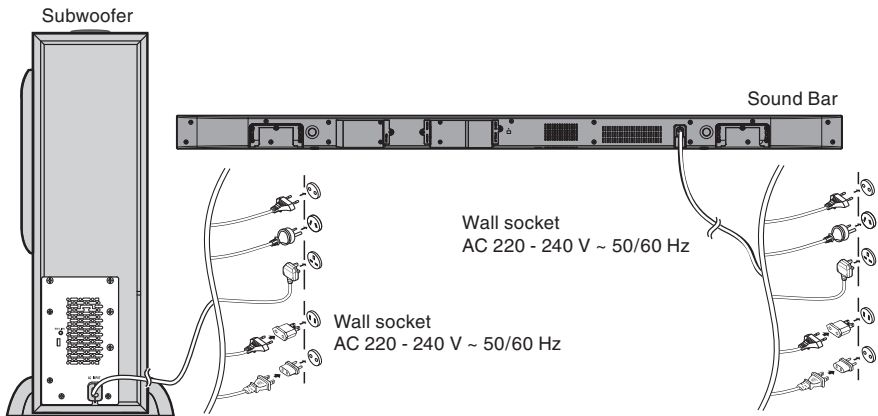

System connections (continued)

IR (Infrared) transmitter connection

If the TV's remote sensor is blocked by the sound bar, use the IR transmitter to relay the signal to the TV.

1. Connect the IR transmitter to IR out terminal to allow the TV's remote signal to pass through.
2. Place the infrared emitter near TV's remote sensor (refer the operation manual of the TV for the location of the sensor).
Point the TV's remote control at the sound bar remote sensor and operate the TV.
You may need to move the IR transmitter until the TV operates correctly.
Then secure the IR transmitter onto the sound bar using the double sided tape provided.

Note:

- Do not use the IR transmitter if the TV's remote control sensor is not blocked by the sound bar.

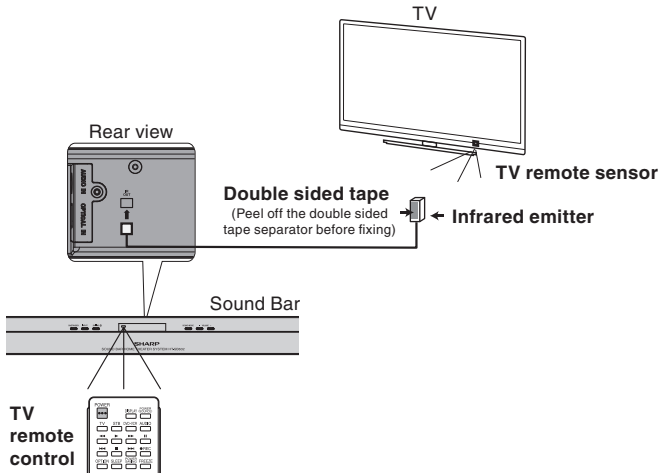

HDMI Connection

Caution:

Turn off all other equipment before making this connection.

The illustration below shows the flows of the signals.

Audio and Video signal



1. Method 1

This connection is for HDMI TV with ARC (Audio Return Channel).

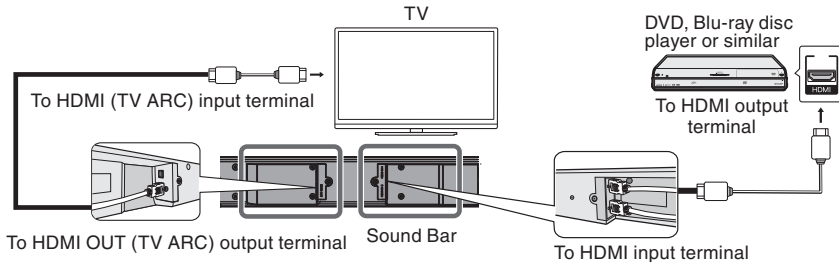

System connections (continued)

2. Method 2

This connection is for HDMI TV without ARC (Audio Return Channel).

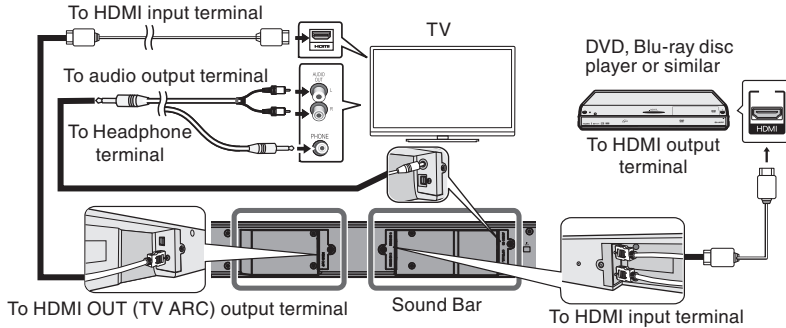

To select HDMI 1, 2 or TV ARC function (Source):

Sound bar operation: Press INPUT button repeatedly until "HDMI 1", "HDMI 2" or "TV ARC" appears on the display.

Remote control operation: Press the desired HDMI button to select.

Notes:

- This sound bar supports HDMI which enables ARC (Audio Return Channel).
- To enable ARC make sure to use High Speed HDMI™ cable (with ARC).
- This ARC feature requires TV that supports ARC. Refer the operation manual of the TV to determine which terminal supports ARC.
- To listen to the sound from a non-ARC-compatible TV, connect the audio output from TV to this system's. (refer this page)
- This sound bar can be operated (power on/off or volume up/down) via a TV or similar component which supports HDMI CEC (Consumer Electronics Control). If this does not work, it does not mean this system is faulty. Refer to the operation manual of the respective component on how to activate the CEC.
Example: Go to the Menu of the component to search and enable the CEC. Different brands may have different naming for the CEC. For SHARP LCD TV, it is named as AQUOS LINK.
- **The system will automatically power off if TV or similar component which supports HDMI CEC, is turned off.**
- CEC is not available during Low power consumption mode.
- **To listen to the sound from this system, you will need to press the TV ⇌ SB () button (refer page 12) or adjust the speaker output settings within the TV menu.**
- For details, refer to the operation manual of the TV.
- **If you are unable to select external speaker setting from the TV menu (E.g. For SHARP LCD TV, it is named as AQUOS AUDIO SP), turn the CEC OFF and ON again.**
- To enjoy 3D images, this system must be connected to a 3D-compatible TV and components (3D BD player, etc.) via High Speed HDMI cables. Put on the 3D glasses, otherwise 3D images may not be viewed properly.
- If you want to use HDMI IN 1 socket, please use the supplied HDMI cable.

Audio connections to TVs, DVD players, VCRs, etc.

■ Other connection (without HDMI)

The illustration below shows the flows of audio and video signals.

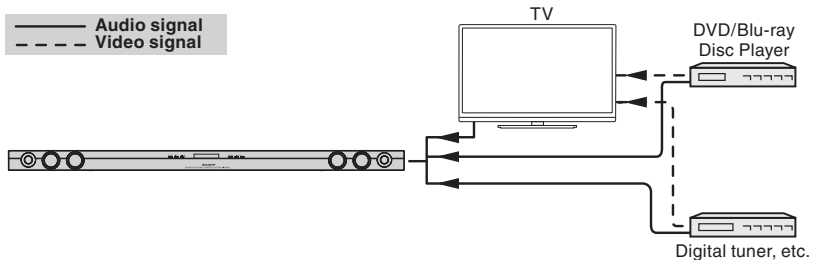

Notes:

- Refer to the operation manual of the equipment to be connected.
- Fully insert the plugs to avoid fuzzy pictures or noises.
- Connecting via this method may disable TV internal speakers.
- In some cases, a small background noise could emit from the sound bar, when you use the RCA audio output terminal connection from a TV-Set/DVD/Blu-ray Disc Player. In such case, please change the connection to the HDMI/ARC or headphone terminal connection. This effect depends on the used TV/DVD/Blu-ray Disc Player-Brand, model and age, and it is not a quality matter from the sound bar.

Audio connections to TVs, DVD players, VCRs, etc. (continued)

■ Connecting a TV, or DVD player, etc.

Connect to the TV using an optical digital cable or an audio cable.

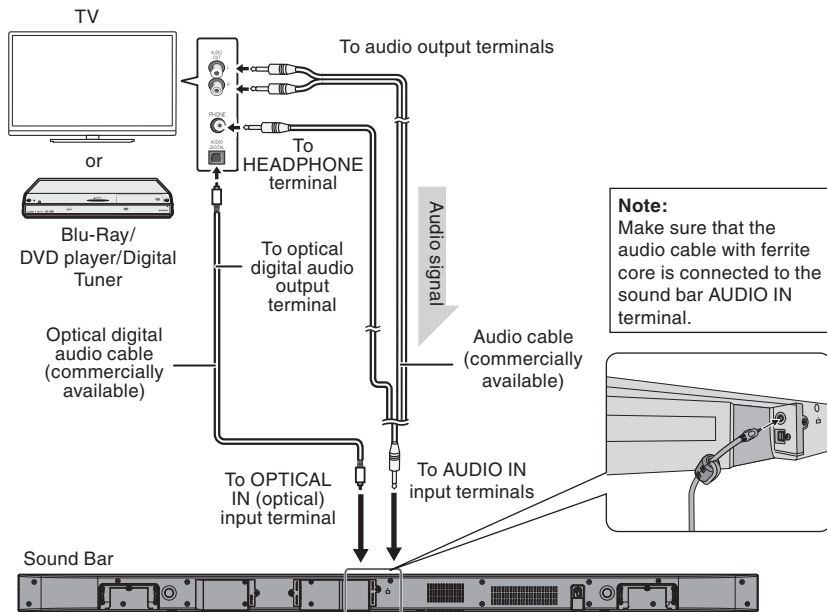

To select OPTICAL function:

Sound bar operation: Press INPUT button repeatedly until "OPTICAL" appears on the display.

Remote control operation: Press the "OPTICAL" button.

To select AUDIO IN function:

Sound bar operation: Press INPUT button repeatedly until "AUDIO IN" appears on the display.

Remote control operation: Press the "AUDIO IN" button.

Remote control

■ Battery installation

- 1 Open the battery cover.
- 2 Insert the batteries according to the direction indicated in the battery compartment.
When inserting or removing the battery, push them towards the ⊖ battery terminals.
- 3 Close the battery cover.

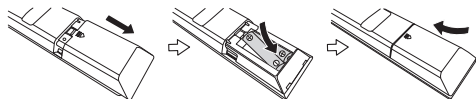

Caution:

- Remove the battery if the sound bar will not be used for a long period of time. This will prevent potential damage due to battery leakage.
- Do not use rechargeable battery (nickel-cadmium battery, etc.).
- Installing the battery incorrectly may cause the sound bar to malfunction.
- Batteries (battery pack or battery installed) shall not be exposed to excessive heat such as sunshine, fire or the like.

Notes concerning use:

- Replace the battery if the operating distance is reduced or if the operation becomes erratic. Purchase 2 "AAA" size battery (UM-4, R03, HP-16 or similar).
- Periodically clean the transmitter on the remote control and the sensor on the sound bar with a soft cloth.
- Exposing the sensor on the sound bar to strong light may interfere with operation. Change the lighting or the direction of the sound bar.
- Keep the remote control away from moisture, heat, shock, and vibrations.

Remote control (continued)

Test of the remote control

Point the remote control directly at the remote sensor on the sound bar.

The remote control can be used within the range shown below:

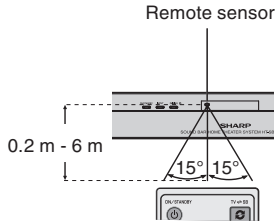

General control

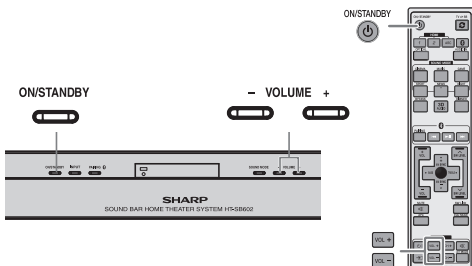

Make sure to enable the HDMI CEC when making HDMI connection. For details, refer to the operation manual of the TV.

To turn the power on

Press the ON/STANDBY button on the sound bar or the remote control.

- The power turns on and the subwoofer indicator turns blue. If the power does not turn on, check whether the AC power lead is plugged in properly.
- The system will automatically power on if TV or similar component which supports HDMI CEC, is turned on.

To set the sound bar to standby mode:

Press the ON/STANDBY button again on the sound bar or the remote control and the subwoofer indicator turns red.

Notes:

- A slight audio delay after TV is turned ON does not mean that the system is faulty. This is normal.
- "AQUOS speaker is enabled" message will be displayed if SHARP LCD TV does not detect HT-SB602 during power on. However the message "AQUOS audio with AQUOS LINK is enabled" will be displayed soon as HT-SB602 is detected. These messages may vary for other TV model.

Standby mode

- The first time the unit is plugged in, it will enter the STANDBY mode.
- To cancel the STANDBY mode, press and hold the ECO MODE button (remote control) during power standby mode. The unit will enter the low power consumption mode.
- To return to the STANDBY mode, press the ECO MODE button again.
- During STANDBY condition, NFC function is activated once your device touches the supplied NFC tag when there is no HDMI connection.

Connecting the wireless Subwoofer

The sound bar and subwoofer will link automatically (wirelessly) when turned on as it is already pre-linked at the factory. If the link cannot be established, please set the connection by the following method.

1. Press and hold the PAIRING button on the sound bar or SW LINK on the remote control for more than 3 seconds.
 2. Within 2 minutes, press and hold the SW LINK button on the subwoofer for more than 3 seconds.
- During pairing process:
On sound bar: "SW LINK" will blink.
On subwoofer: indicator will blink in blue.
 - When pairing is successful:
On sound bar: "SW LINK" disappears.
On subwoofer: indicator turns blue.

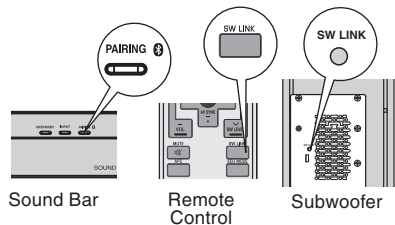

Notes:

- If a device such as microwave oven, wireless LAN card, Bluetooth device or any other device that uses the same 2.4GHz frequency near the system, some sound interruption may be heard due to interference.
- The transmission distance of the wireless signal between the subwoofer and sound bar is about 10m (32 feet), but may vary depending on your operating environment. If a steel-concrete or metallic wall is between the subwoofer and the sound bar, the system may not operate at all, because the wireless signal cannot penetrate metal.

Caution:

- Keep the subwoofer away from water and moisture.
- To get the optimum listening performance, make sure the area around the sound bar and subwoofer is clear of any obstacles.

General control (continued)

■ Display brightness control

Press the DIMMER button to adjust the brightness of the display.



■ Volume auto fade-in

If you turn off and on the sound bar with the volume set to 80 or higher, the volume starts at 40 and fades in to the last set level.

■ Volume control

Sound bar operation:

Press the VOLUME + button to increase the volume and the VOLUME – button for decreasing.

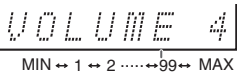

Remote control operation:

Press the VOL + button to increase the volume and the VOL – button to decrease the volume.

■ Muting

The volume is muted temporarily when pressing the (MUTE) button on the remote control. Press again to restore the volume.

Note:

When the sound bar is turned off and back on again, muting is cancelled.

■ Sound Mode

Sound bar operation:

To change to a different mode, press the SOUND MODE button repeatedly until the desired sound mode is displayed.

Remote control operation:

Press the desired sound mode button.

CINEMA	(for cinema sound effect)
MUSIC	(for standard sound effect)
GAME	(for game sound effect)
SPORT	(for sport broadcasting)
NEWS	(for news)
NIGHT	(for night)
BYPASS	(for flat sound effect)

■ Bass and Treble Control

Bass and Treble control is applicable during BYPASS mode only.

Bass Control

1. Press the BASS button.
2. Within 5 seconds, press the VOL (+ or –) button to adjust the bass.

Treble Control

1. Press the TREBLE button.
2. Within 5 seconds, press the VOL (+ or –) button to adjust the treble.

■ Subwoofer level control

The subwoofer level can be adjusted.

To increase the level, press the SW LEVEL ^ button.

To decrease the level, press the SW LEVEL v button.

Notes:

- When sound from the speaker is distorted, decrease the subwoofer level.
- When changing the subwoofer level, the output level of the subwoofer is also changed.

■ AV SYNC level control

The AV SYNC level can be adjusted.

To increase the level, press the AV SYNC + button.

To decrease the level, press the AV SYNC – button.

■ Speaker output selection (HDMI connection)

Press TV button on the remote control until "TV SPEAKER" or "SB SPEAKER" appears on the display to toggle sound output between this sound bar or TV.

■ Function

HDMI 1 → HDMI 2 → TV ARC → OPTICAL → AUDIO IN → BLUETOOTH

Sound bar operation:

Press the INPUT button repeatedly to select the desired input source.

Remote control operation:

Press the desired function button.

Note:

The backup function will protect the memorised function mode for a few hours should there be a power failure or the AC power lead becomes disconnected.

Bluetooth one touch connection via NFC

About NFC technology

Near Field Communication (NFC) is a set of standards for devices (smartphones/tablets) to establish radio communication with each other by touching/tapping them together or bringing them into close proximity.

Using NFC in this product simplifies the pairing method of Bluetooth connectivity.

- This audio system supports NFC-enabled device with Android 4.1, Jelly Bean and higher.
- For device with a lower Android version, refer the operation manual of the device for recommended app (application).

Unlike other wireless technology, NFC requires no discovery or pairing.

Simply tap the source device to the NFC detection area on the subwoofer or NFC tag to instantly enjoy seamless connectivity between your smart device and the audio system.

NFC detection area

NFC detection area location may vary depending on the device (smartphone / tablet). Refer operation manual of the device for detail.

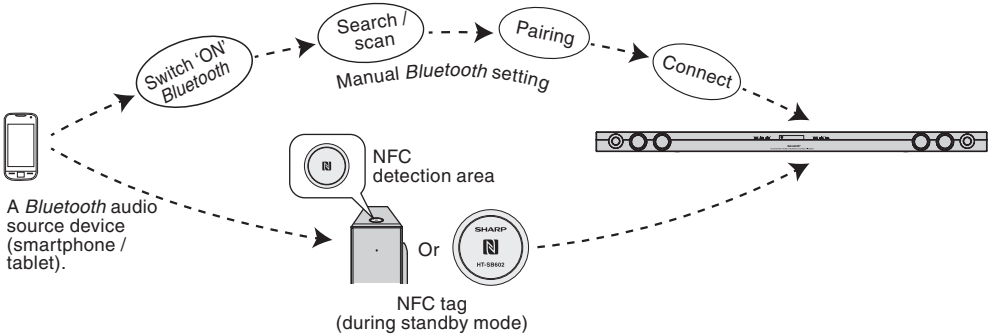

NFC tag set up

The NFC tags can be placed anywhere convenient to you. The velcro tapes supplied will help to secure the tags onto the desired location.

Caution :

- Make sure that the NFC tag is placed on a flat and level surface.
- If you choose not to use the velcro tape, do not place the NFC tag near metal surface to avoid connection interference during tagging.

Important:

- NFC tag provided has unique ID for each sound bar.
- SHARP will not be held liable for the damages caused by rewriting the tags.

Keep all small parts away from children as they may be accidentally swallowed.

- 1 Peel the separator off the velcro tape (loop type) and stick it on a desired surface.

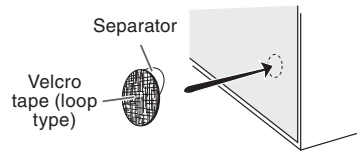

- 2 Peel the separator off the velcro tape (hook type) and stick it to the rear of the NFC tag. Then place the tag onto the desired location.

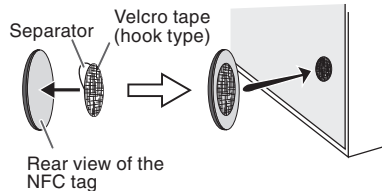

Bluetooth one touch connection via NFC (continued)

NFC connection for audio playback

Check that:

- Your device (smartphone / tablet) has an NFC function.
- NFC function on your device is turned on.
- Screen lock function of the device is off.
- This unit is not in Eco mode.

- 1 Touch your device to the NFC detection area on the subwoofer or supplied NFC tag.

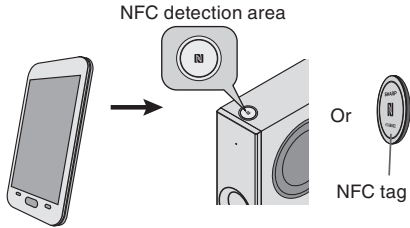

- 2 A pop-up window asking whether to proceed with the Bluetooth connection appears on the device. Select <YES>.
- The 'connected' message appears when the connection is complete.

- 3 Playback will start automatically. Otherwise, press play (on remote control or source device).

- Sound will be heard from the speakers of this unit via audio streaming.
- Your device must be within 10 meters from the sound bar.

Bluetooth operation buttons (remote control only)

	Press the button to play or pause.
	Press the button to skip up. Press and hold to fast forward.
	Press the button to skip down. Press and hold to fast reverse.

Notes:

- To disconnect, simply touch your device to the NFC detection area on the subwoofer or NFC tag again.
- To listen to audio via Bluetooth connectivity without NFC tag - refer "Pairing with other Bluetooth source devices" on page 16.
- It takes about 6-8 seconds for a Bluetooth enabled device (eg. smartphone) to establish Bluetooth connection with this unit via NFC or manual connection.

Listening to Bluetooth enabled devices

Bluetooth

Bluetooth wireless technology is a short-range radio technology that enables wireless communication between various types of digital devices, such as mobile phone or computer. It operates within a range of about 10 meters (30 feet) without the hassle of having to use cables to connect these devices.

This unit supports the following:

Communication System: Bluetooth Specification version 2.1 Bluetooth + Enhanced Data Rate (EDR).
Support Profile : A2DP (Advanced Audio Distribution Profile) and AVRCP (Audio/Video Remote Control Profile)

Notes when using unit with a mobile phone

- This unit cannot be used to talk over the telephone even when there is a Bluetooth connection made to a mobile phone.
- Please refer to the operating manual supplied with the mobile phone for details on operation of your mobile phone whilst transmitting the sound using a Bluetooth connection.

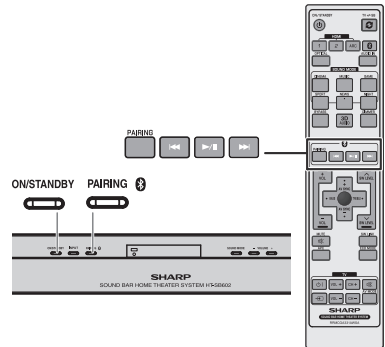

Pairing Bluetooth devices

Bluetooth devices need to be initially paired first before they can exchange data. Once paired, it is not necessary to pair them again unless:

- Pairing is made with more than 8 devices. Pairing can only be made one device at a time. This unit can be paired to a maximum of 8 devices. If subsequent device is paired, the oldest device paired, will be deleted and replaced with the new one.
- This unit is reset. All pairing information is deleted when unit is reset.
- Pairing information is deleted whilst re-pairing, etc.

Listening to Bluetooth enabled devices (continued)

Indicators:

Indicator	Condition	Bluetooth status
▶ ◀	Blinks	In waiting or pairing mode
▶ ● ◀	Lights up	Connected
No indication		Unconnected

However, the indication status is not displayed during standby mode.

■ Pairing with other Bluetooth source devices

- 1 Press the POWER ON/STANDBY button to turn the power on.
- 2 Press the INPUT button (sound bar) repeatedly or **ⓑ** (Bluetooth) button (remote control) to select Bluetooth function. "BLUETOOTH" appears on the display.

3 Sound bar operation: Press PAIRING button.

Remote control operation: Press and hold the PAIRING button for 3 seconds or more.

"START PAIRING" appears on the display. The unit is now in pairing mode and is ready to be paired with other Bluetooth source device.

- 4 Perform pairing procedure on the source device to detect this unit. "HT-SB602 SHARP" will appear in the detected devices list (if available) in the source device. (Refer the source device operating manual for details).

Notes:

- Place the devices to be paired within 1 meter (3 feet) of each other when pairing.
- Some source devices are unable to display lists of detected devices. To pair this unit with the source device, refer to the source device operating manual for details.

- 5 Select "HT-SB602 SHARP" from the source list. If Passcode* is required, enter "0000".
* Passcode may be called PIN Code, Passkey, PIN number or Password.
- 6 "CONNECTED" appears on the display once the unit is successfully paired with the source device. (Pairing information is now memorised in the unit.) Some audio source devices may connect with the unit automatically after pairing is completed, otherwise follow the instructions in the source device operating manual to start connection.
- 7 Press the play button on sound bar, remote control or source device to start Bluetooth streaming playback.

Notes:

- If a device such as microwave oven, wireless LAN card, Bluetooth device or any other device that uses the same 2.4 GHz frequency near the system some sound interruption may be heard.
- The transmission distance of the wireless signal between the device and the sound bar is about 10 m (32 feet), but may vary depending on your operating environment. If a steel concrete or metallic wall is between the device and the sound bar, the system may not operate at all, because the wireless signal cannot penetrate metal.

- If this unit or the source device is turned off before Bluetooth connection is completed, pairing will not be completed and the pairing information will not be memorised. Repeat step 1 onwards to start pairing again.
- To pair with other devices, repeat steps 1 - 5 for each device. This unit can be paired to a maximum of 8 devices. If subsequent device is paired, the oldest device paired, will be deleted and replaced with the new one.
- Once a device is ousted or deleted from the pairing list, the pairing information for the device is also deleted. To listen to the sound from the device again, it needs to be re-paired. Perform steps 1 - 5 to pair the device again.

■ Listening to the sound

Check that:

- The source device Bluetooth functionality is ON.
- Pairing of this unit and the source device is completed.
- Unit is in connected mode.

- 1 Press the POWER ON/STANDBY button to turn the power on.
- 2 Press the INPUT button (sound bar) repeatedly or **ⓑ** (Bluetooth) button (remote control) to select Bluetooth function.
- 3 Start the Bluetooth connection from the Bluetooth stereo audio source device.
- 4 Press the Bluetooth **▶/||** button.

Notes:

- For various Bluetooth operations, refer "NFC connection for audio playback" on page 15.
- If the source device has an extra bass function or equalizer function, set them to off to avoid sound distortion.

Note:

- Make the Bluetooth connection again if the source device is not turned on, or its Bluetooth functionality is off or is in sleep mode.

■ To disconnect the Bluetooth device

Perform any of the followings.

- Disconnect the Bluetooth connection on the audio source device. Refer the operating manual supplied with the device.
- Turn off the Bluetooth stereo audio source device.
- Turn off this unit.

Note:

The volume of this unit may not be controlled as intended depending on the device.

■ Auto power on

During Standby mode, when music is played from your device, the unit will automatically power on when the Bluetooth connection has been set up between the sound bar and your device. They remain connected if there is no HDMI connection.

Note:

This function is not applicable during ECO mode.

Operating the TV with the remote control



You can operate Sharp TVs with this system's remote control.

■ Watching TV

Point the remote control at the TV.

- 1 Press the TV (⏻) ON/STANDBY button to turn on the TV.**
- 2 Pressing the TV CH + or – button enables TV channel switching.**
- 3 Press the TV VOL + or – button to adjust the TV volume.**

Other operable button

Input Select Button	
Mute (TV)	
AV mode	

Troubleshooting chart

Many potential problems can be resolved by the owner without calling a service technician.

If something is wrong with this product, check the following before calling your authorized SHARP dealer or service centre.

■ General

Symptom	Possible cause
<ul style="list-style-type: none"> ● No sound is heard. 	<ul style="list-style-type: none"> ● Is the input signal (selection) set properly? ● Is the volume level set to "MIN"? ● Is muting activated? ● Is HDMI compliant equipment being used? ● Is the HDMI cable connected correctly? Connect the HDMI cable correctly and then perform the reset procedure. (refer page 18) ● Do not connect or disconnect an HDMI cable whilst power is on. This may lead to operation problems.
<ul style="list-style-type: none"> ● The sound from subwoofer is not well balanced. 	<ul style="list-style-type: none"> ● Is the subwoofer level set to the minimum or maximum level?
<ul style="list-style-type: none"> ● Power turns off suddenly. 	<ul style="list-style-type: none"> ● Is the HDMI cable connected correctly? Connect the HDMI cable correctly and then perform the reset procedure.
<ul style="list-style-type: none"> ● Noise is heard during playback. 	<ul style="list-style-type: none"> ● Move the speaker away from any computers or mobile phones.
<ul style="list-style-type: none"> ● When a button is pressed, the sound bar does not respond. 	<ul style="list-style-type: none"> ● Set the sound bar to the standby mode and then turn it back on.
<ul style="list-style-type: none"> ● The power is not turned on. 	<ul style="list-style-type: none"> ● Is the sound bar unplugged? ● The protection circuit may be activated. Unplug and plug in the power lead again after 5 minutes or more.
<ul style="list-style-type: none"> ● 3D images not displayed on the TV. 	<ul style="list-style-type: none"> ● Depending on the TV and Video component, 3D images may not be displayed. Check the operation manual of the respective component. ● HDMI cable not support 3D image.
<ul style="list-style-type: none"> ● Background noise appears when connecting with RCA audio output terminal connection from a TV-set/ DVD/Blu-ray Disc Player. 	<ul style="list-style-type: none"> ● Please change to HDMI/ARC or headphone terminal from TV-Set/ DVD/Blu-ray Disc Player. This effect may occur depending on TV/DVD/Blu-ray Disc Player-Brand, model and age, and it is not the sound bar problem.
<ul style="list-style-type: none"> ● Wireless connection cannot be established. 	<ul style="list-style-type: none"> ● Check the distance between the sound bar and subwoofer (less than 10m (32 feet)). ● Make sure there is no other wireless devices near the unit.

Troubleshooting chart (continued)

Symptom	Possible cause
<ul style="list-style-type: none"> ● Wireless connection cannot be established. 	<ul style="list-style-type: none"> ● Make sure there is no obstacles (especially metal) blocking between the sound bar and subwoofer. ● Manually re-link the sound bar and subwoofer (refer page 11).

■ If problem occurs during operation

When this product is subject to strong external interference (mechanical shock, excessive static electricity, abnormal supply voltage due to lightning, etc.) or if it is operated incorrectly, it may malfunction.

If such a problem occurs, do the following:

1. Set the sound bar to the standby mode and turn the power on again.
2. If the sound bar is not restored in the previous operation, unplug and plug in the sound bar again, and then turn the power on.

■ Factory reset, clearing all memory

Make sure to disconnect all output and input cables attached to the sound bar before performing the factory reset.

1. Press the ON/STANDBY button to enter the power standby mode.
2. Whilst pressing the SOUND MODE button, press and hold the ON/STANDBY button until "RESET" appears.



Caution:

This operation will erase all data stored in memory.

■ NFC / Bluetooth

Symptom	Possible cause
<ul style="list-style-type: none"> ● No sound is heard. 	<ul style="list-style-type: none"> ● The unit is too far from the <i>Bluetooth</i> stereo audio source device. ● The unit is not paired with the <i>Bluetooth</i> stereo audio source device.
<ul style="list-style-type: none"> ● <i>Bluetooth</i> sound is interrupted or distorted. 	<ul style="list-style-type: none"> ● The unit is too near to a device that generates electromagnetic radiation. ● There is an obstacle between the unit and the <i>Bluetooth</i> stereo audio source device.
<ul style="list-style-type: none"> ● NFC-enabled device cannot connect to <i>Bluetooth</i> via NFC tag. 	<ul style="list-style-type: none"> ● Sound bar is not in <i>Bluetooth</i> pairing mode. Perform "NFC connection for audio playback". (Refer page 15.)

■ Remote control

Symptom	Possible cause
<ul style="list-style-type: none"> ● The remote control does not operate properly. 	<ul style="list-style-type: none"> ● Is the battery polarity correct? ● Is the battery dead? ● Is the distance or angle incorrect? ● Are there any obstructions in front of the sound bar? ● Is there a strong light shining on the remote sensor? ● Is the remote control for another equipment used simultaneously?
<ul style="list-style-type: none"> ● The sound bar cannot be turned on with the remote control. 	<ul style="list-style-type: none"> ● Is the AC power lead of the sound bar plugged in? ● Is the battery inserted?

■ Condensation

Sudden temperature changes, storage or operation in an extremely humid environment may cause condensation inside the cabinet or on the transmitter on the remote control. Condensation can cause the sound bar to malfunction. If this happens, leave the power on until normal playback is possible (about 1 hour). Wipe off any condensation on the transmitter with a soft cloth before operating the sound bar.

Maintenance

■ Cleaning the cabinet



Periodically wipe the cabinet with a soft cloth.

Caution:

- Do not use chemicals for cleaning (petrol, paint thinner, etc.). It may damage the cabinet finish.
- Do not apply oil to the inside of each component. It may cause malfunctions.

Error indicators and warnings

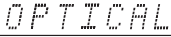
When you fail to perform operations properly, the following messages are displayed on the sound bar.

Display	Meaning
 (Display blinks)	<ul style="list-style-type: none"> ● When there is no input signal. Play back the connected equipment. ● Nonstandard signal. Cannot be recognized. ● Signals other than DOLBY DIGITAL, DTS, Linear PCM cannot be recognized. ● Poor connection of the digital audio input terminal. ● Turn off the sound bar and check if the cable is connected properly.
 Error indicator (blinks red)	<ul style="list-style-type: none"> ● When the protection circuit is activated.

(*): Should the same message appear even if the speaker is unplugged and plugged in, or is set to the standby mode and on again, contact your local dealer where you purchased the sound bar.

Specifications

As part of our policy of continuous improvement, SHARP reserves the right to make design and specification changes for product improvement without prior notice. The performance specification figures indicated are nominal values of production unit. There may be some deviations from these values in individual unit.

■ Sound Bar

Power source	AC 220 - 240 V ~ 50/60 Hz
Power consumption	Power on: 38 W Power standby: 0.4 W (*1) Power standby: < 6 W (*2)
Dimension	Width: 1386 mm Height: 74 mm Depth: 68 mm
Weight	3.7 kg

Output power	MPO: 160W (80W + 80W) (10% T.H.D.) RMS: Total 160 watts RMS: 160 W (80 W + 80 W) (10% T.H.D.) RMS: 120 W (60 W + 60 W) (1% T.H.D.)
Output terminal	HDMI™ output: (audio/video support up to 1080p) x 1
Input terminal	500 mV / 47 kohms Optical digital input (OPTICAL): Square type x 1 HDMI input: (audio/video support up to 1080p) x 2
Type	2 Way speaker system 5.7 cm woofer 2.5 cm Soft Dome
Bluetooth Frequency band	2.400GHz - 2.480GHz
Compatible Bluetooth Profile	A2DP (Advanced Audio Distribution Profile), AVRCP (Audio/Video Remote Control Profile) <i>Bluetooth 2.1 +EDR</i>
Maximum input power	160 W
Rated input power	80 W
Impedance	4 ohms

(*1): This power consumption value is obtained when the sound bar is in low power consumption mode.

(*2): This power consumption value is obtained in the STANDBY mode.

■ Subwoofer

Power source	AC 220 - 240 V ~ 50/60 Hz
Power consumption	Power on: 33 W Power standby: 0.4 W (*1) Power standby: 0.4 W (*2)
Output power	MPO: 150W (10% T.H.D.) RMS: 150 W (10% T.H.D.) RMS: 120 W (1% T.H.D.)
Type	Subwoofer system 16 cm woofer
Maximum input power	300 W
Rated input power	150 W
Impedance	3 ohms
Dimensions	Width: 144 mm Height: 432 mm Depth: 306 mm
Weight	6.1 kg

SHARP

FOR LOCATION ENQUIRIES WITHIN

AUSTRALIA

REGARDING YOUR LOCAL

SHARP APPROVED SERVICE CENTRE

VISIT OUR WEBSITE AT

www.sharp.net.au

OR CALL SHARP CUSTOMER CARE

1300 135 022

(LOCAL CALL COSTS APPLY WITHIN AUSTRALIA)

SHARP CORPORATION OF AUSTRALIA PTY LTD

SHARP

FOR LOCATION ENQUIRIES WITHIN

NEW ZEALAND

REGARDING YOUR LOCAL

SHARP APPROVED SERVICE CENTRE

VISIT OUR WEBSITE AT

www.sharp.net.nz

CONTACT YOUR SELLING DEALER/RETAILER

OR CALL

SHARP CUSTOMER SERVICES

TELEPHONE: 09 573 0111

FACSIMILE: 09 573 0113

SHARP CORPORATION OF NEW ZEALAND LIMITED

SHARP

WARRANTY

Consumer Electronic Products

Congratulations on Your Purchase!

This Sharp product is warranted against faults in material and manufacture for the period as stated in the table below.

If service is required during the warranty period, please contact your nearest Sharp Approved Service Centre. These repairs would be carried out at no charge to the owner, subject to the conditions specified herein.

This warranty does not extend to defects or injuries caused by or resulting from causes not attributable to faulty parts or the manufacture of the product, including but not limited to, defect or injury caused by or resulting from misuse, abuse, neglect, lack of maintenance, accidental damage, improper voltage, liquid spillage, vermin infestation, software, or any alterations made to the product which are not authorised by Sharp.

Please retain your sales documentation, as this should be produced to validate a warranty claim. This warranty is in addition to and in no way limits, varies or excludes any implied rights and remedies under any relevant legislation in the country of sale.

This warranty does not cover transportation to and from the Sharp Approved Service Centre. Goods presented for repair may be replaced by refurbished goods of the same type rather than being repaired. Refurbished parts may be used to repair the goods. The repair of your goods may result in the loss of user generated data, please ensure that you have saved this data elsewhere prior to repair.

Australian customers: Our goods come with guarantees that cannot be excluded under the Australian Consumer Law. You are entitled to a replacement or refund for a major failure and for compensation for any other reasonably foreseeable loss or damage. You are also entitled to have the goods repaired or replaced if the goods fail to be of acceptable quality and the failure does not amount to a major failure. The criteria of a major failure is defined in the Australian Consumer Law. Should you require any assistance with a major failure please contact Sharp Customer Care.

WARRANTY PERIODS

Home Theatre Projector	12 months (excluding lamps and air filters)
Audio/Home Theatre	12 months
Microwave Oven	12 months
Steam Oven	12 months
Refrigerator	24 months
DVD/Blu-ray	12 months
Air Conditioner	60 months
Portable Air Conditioner	12 months
LCD Television	12 months
Air Purifier	12 months
Vacuum Cleaner	24 months

SHARP
SHARP CORPORATION OF
AUSTRALIA PTY. LIMITED
ABN 60 003 939 405
1 Huntingwood Drive
Huntingwood NSW 2148

SHARP CORPORATION OF
NEW ZEALAND LIMITED
59 Hugo Johnston Drive
Penrose, Auckland

SP4errm 040 (JUNE 2012)

IMPORTANT NOTICE: This warranty applies only to products sold in Australia & New Zealand

SHARP®

SHARP CORPORATION

Free Manuals Download Website

<http://myh66.com>

<http://usermanuals.us>

<http://www.somanuals.com>

<http://www.4manuals.cc>

<http://www.manual-lib.com>

<http://www.404manual.com>

<http://www.luxmanual.com>

<http://aubethermostatmanual.com>

Golf course search by state

<http://golfingnear.com>

Email search by domain

<http://emailbydomain.com>

Auto manuals search

<http://auto.somanuals.com>

TV manuals search

<http://tv.somanuals.com>