

# ***SYLVANIA*** **SERVICE MANUAL**

## **32" COLOR TELEVISION SRT2232X**

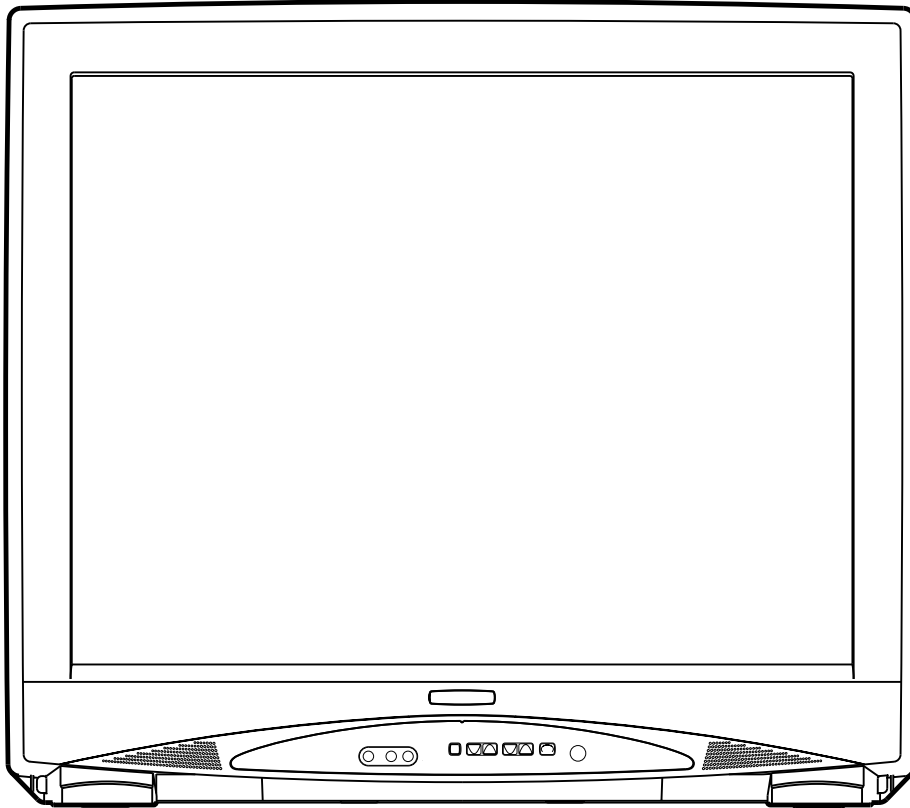

# IMPORTANT SAFETY NOTICE

Proper service and repair is important to the safe, reliable operation of all Funai Equipment. The service procedures recommended by Funai and described in this service manual are effective methods of performing service operations. Some of these service special tools should be used when and as recommended.

It is important to note that this service manual contains various CAUTIONS and NOTICES which should be carefully read in order to minimize the risk of personal injury to service personnel. The possibility exists that improper service methods may damage the equipment. It also is important to understand that these CAUTIONS and NOTICES ARE NOT EXHAUSTIVE. Funai could not possibly know, evaluate and advise the service trade of all conceivable ways in which service might be done or of the possible hazardous consequences of each way. Consequently, Funai has not undertaken any such broad evaluation. Accordingly, a servicer who uses a service procedure or tool which is not recommended by Funai must first use all precautions thoroughly so that neither his safety nor the safe operation of the equipment will be jeopardized by the service method selected.

## TABLE OF CONTENTS

Specifications .....	1-1	CBA Views and Test Points.....	7-11
Important Safety Precautions.....	2-1	Wave Forms .....	8-1
Standard Notes for Servicing .....	3-1	Wiring Diagram.....	9-1
Disassembly Instructions .....	4-1	IC Pin Function .....	10-1
Electrical Adjustment Instructions .....	5-1	Cabinet Exploded View .....	11-1
Block Diagram.....	6-1	Packing Exploded View .....	11-3
Schematic Diagram / CBA's and Test Points .....	7-1	Mechanical Parts List .....	12-1
Schematic Diagram .....	7-3	Electrical Parts List.....	13-1

# SPECIFICATIONS

## <TUNER>

ANT. Input ----- 75ohm Unbal., F type  
 Reference Level ----- 20Vp-p (CRT Green Cathode)  
 Test Input Signal ----- 400Hz 30% modulation

Description	Condition	Unit	Nominal	Limit
1. Intermediate Freq.	Picture	MHz	45.75	—
	Sound	MHz	41.25	—
2. Peak Picture Sens	VHF	dB $\mu$ V	15	30
	CATV	dB $\mu$ V	15	30
	UHF	dB $\mu$ V	15	40
3. AFT Pull In Range (10mV input)	—	MHz	$\pm$ 2.2	$\pm$ 0.7

## <DEFLECTION>

Description	Condition	Unit	Nominal	Limit
1. Deflection Freq.	Horizontal	KHz	15.734	—
	Vertical	Hz	60	—
2. Linearity	Horizontal	%	—	$\pm$ 15
	Vertical	%	—	$\pm$ 10
3. Over Scan	—	%	10	—
4. High Voltage	—	KV	29	—

## <VIDEO & CHROMA>

Description	Condition	Unit	Nominal	Limit
1. Misconvergence	Center	mm	—	0.4
	Side	mm	—	1.5
	Corner	mm	—	2.1
2. Brightness	APL 100%	Ft-L	20	15
3. Color Temperature	—	$^{\circ}$ K	9200 $^{\circ}$ K	—
4. Resolution	Horizontal	Line	250	—
	Vertical	Line	300	—

## <AUDIO>

All items are measured across 8 $\Omega$  load at speaker output terminal.

Description	Condition	Unit	Nominal	Limit
1. Audio Output Power	10% THD	W	3	2.4
2. Audio Distortion (w/LPF)	500mW	%	1.0	7
3. Audio Freq. Response	-3dB	Hz	90~11K	—

### Note:

Nominal specifications represent the design specifications. All units should be able to approximate these. Some will exceed and some may drop slightly below these specifications. Limit specifications represent the absolute worst condition that still might be considered acceptable. In no case should a unit fail to meet limit specifications.

# IMPORTANT SAFETY PRECAUTIONS

Prior to shipment from the factory, our products are strictly inspected for recognized product safety and electrical codes of the countries in which they are to be sold. However, in order to maintain such compliance, it is equally important to implement the following precautions when a set is being serviced.

## Safety Precautions for TV Circuit

1. **Before returning an instrument to the customer**, always make a safety check of the entire instrument, including, but not limited to, the following items:

- a. Be sure that no built-in protective devices are defective and have been defeated during servicing.  
(1) Protective shields are provided on this chassis to protect both the technician and the customer. Correctly replace all missing protective shields, including any removed for servicing convenience.  
(2) When reinstalling the chassis and/or other assembly in the cabinet, be sure to put back in place all protective devices, including but not limited to, nonmetallic control knobs, insulating fishpapers, adjustment and compartment covers/shields, and isolation resistor/capacitor networks. **Do not operate this instrument or permit it to be operated without all protective devices correctly installed and functioning. Servicers who defeat safety features or fail to perform safety checks may be liable for any resulting damage.**
- b. Be sure that there are no cabinet openings through which an adult or child might be able to insert their fingers and contact a hazardous voltage. Such openings include, but are not limited to, (1) spacing between the picture tube and the cabinet mask, (2) excessively wide cabinet ventilation slots, and (3) an improperly fitted and/or incorrectly secured cabinet back cover.
- c. **Antenna Cold Check** - With the instrument AC plug removed from any AC source, connect an electrical jumper across the two AC plug prongs. Place the instrument AC switch in the on position. Connect one lead of an ohmmeter to the AC plug prongs tied together and touch the other ohmmeter lead in turn to each tuner antenna input exposed terminal screw and, if applicable, to the coaxial connector. If the measured resistance is less than 1.0 megohm or greater than 5.2 megohm, an abnormality exists that must be corrected before the instrument is returned to the customer. Repeat this test with the instrument AC switch in the off position.
- d. **Leakage Current Hot Check** - With the instrument completely reassembled, plug the AC line cord directly into a 120V AC outlet. (Do not use an isolation transformer during this test.) Use a leak-

age current tester or a metering system that complies with American National Standards Institute (ANSI) C101.1 Leakage Current for Appliances and Underwriters Laboratories (UL) 1410, (50.7). With the instrument AC switch first in the on position and then in the off position, measure from a known earth ground (metal water pipe, conduit, etc.) to all exposed metal parts of the instrument (antennas, handle brackets, metal cabinet, screw heads, metallic overlays, control shafts, etc.), especially any exposed metal parts that offer an electrical return path to the chassis. Any current measured must not exceed 0.5 milli-ampere. Reverse the instrument power cord plug in the outlet and repeat the test.

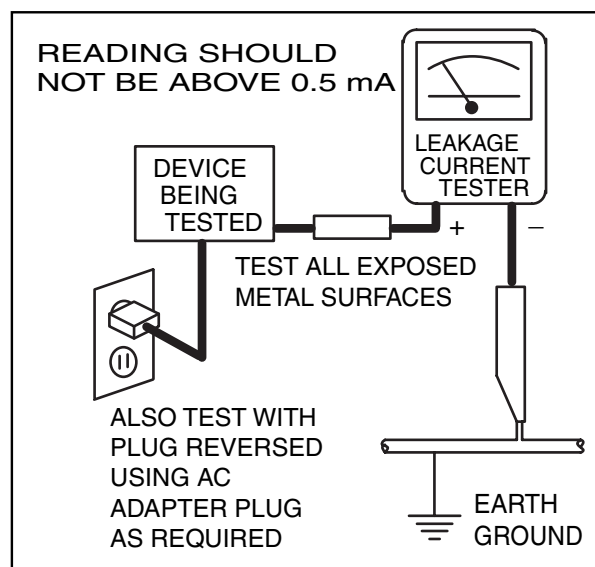

**ANY MEASUREMENTS NOT WITHIN THE LIMITS SPECIFIED HEREIN INDICATE A POTENTIAL SHOCK HAZARD THAT MUST BE ELIMINATED BEFORE RETURNING THE INSTRUMENT TO THE CUSTOMER OR BEFORE CONNECTING THE ANTENNA OR ACCESSORIES.**

- e. **X-Radiation and High Voltage Limits** - Because the picture tube is the primary potential source of X-radiation in solid-state TV receivers, it is specially constructed to prohibit X-radiation emissions. For continued X-radiation protection, the replacement picture tube must be the same type as the original. Also, because the picture tube shields and mounting hardware perform an X-radiation protection function, they must be correctly in place. High voltage must be measured each time servic-

ing is performed that involves B+, horizontal deflection or high voltage. Correct operation of the X-radiation protection circuits also must be reconfirmed each time they are serviced. (X-radiation protection circuits also may be called "horizontal disable" or "hold down.") Read and apply the high voltage limits and, if the chassis is so equipped, the X-radiation protection circuit specifications given on instrument labels and in the Product Safety & X-Radiation Warning note on the service data chassis schematic. High voltage is maintained within specified limits by close tolerance safety-related components/adjustments in the high-voltage circuit. If high voltage exceeds specified limits, check each component specified on the chassis schematic and take corrective action.

2. Read and comply with all caution and safety-related notes on or inside the receiver cabinet, on the receiver chassis, or on the picture tube.

3. **Design Alteration Warning** - Do not alter or add to the mechanical or electrical design of this TV receiver. Design alterations and additions, including, but not limited to circuit modifications and the addition of items such as auxiliary audio and/or video output connections, might alter the safety characteristics of this receiver and create a hazard to the user. Any design alterations or additions will void the manufacturer's warranty and may make you, the servicer, responsible for personal injury or property damage resulting therefrom.

4. **Picture Tube Implosion Protection Warning** - The picture tube in this receiver employs integral implosion protection. For continued implosion protection, replace the picture tube only with one of the same type number. Do not remove, install, or otherwise handle the picture tube in any manner without first putting on shatterproof goggles equipped with side shields. People not so equipped must be kept safely away while picture tubes are handled. Keep the picture tube away from your body. Do not handle the picture tube by its neck. Some "in-line" picture tubes are equipped with a permanently attached deflection yoke; because of potential hazard, do not try to remove such "permanently attached" yokes from the picture tube.

5. **Hot Chassis Warning** -

a. Some TV receiver chassis are electrically connected directly to one conductor of the AC power cord and maybe safety-serviced without an isolation transformer only if the AC power plug is inserted so that the chassis is connected to the ground side of the AC power source. To confirm that the AC power plug is inserted correctly, with an AC voltmeter, measure between the chassis and a known

earth ground. If a voltage reading in excess of 1.0V is obtained, remove and reinsert the AC power plug in the opposite polarity and again measure the voltage potential between the chassis and a known earth ground.

b. Some TV receiver chassis normally have 85V AC(RMS) between chassis and earth ground regardless of the AC plug polarity. This chassis can be safety-serviced only with an isolation transformer inserted in the power line between the receiver and the AC power source, for both personnel and test equipment protection.

c. Some TV receiver chassis have a secondary ground system in addition to the main chassis ground. This secondary ground system is not isolated from the AC power line. The two ground systems are electrically separated by insulation material that must not be defeated or altered.

6. Observe original lead dress. Take extra care to assure correct lead dress in the following areas:a. near sharp edges,b. near thermally hot parts-be sure that leads and components do not touch thermally hot parts,c. the AC supply,d. high voltage, and,e. antenna wiring. Always inspect in all areas for pinched, out of place, or frayed wiring. Check AC power cord for damage.

7. Components, parts, and/or wiring that appear to have overheated or are otherwise damaged should be replaced with components, parts, or wiring that meet original specifications. Additionally, determine the cause of overheating and/or damage and, if necessary, take corrective action to remove any potential safety hazard.

8. **Product Safety Notice** - Some electrical and mechanical parts have special safety-related characteristics which are often not evident from visual inspection, nor can the protection they give necessarily be obtained by replacing them with components rated for higher voltage, wattage, etc.. Parts that have special safety characteristics are identified by a (▲) on schematics and in parts lists. Use of a substitute replacement that does not have the same safety characteristics as the recommended replacement part might create shock, fire, and/or other hazards. The product's safety is under review continuously and new instructions are issued whenever appropriate. Prior to shipment from the factory, our products are strictly inspected to confirm they comply with the recognized product safety and electrical codes of the countries in which they are to be sold. However, in order to maintain such compliance, it is equally important to implement the following precautions when a set is being serviced.

## Precautions during Servicing

**A.** Parts identified by the (  ) symbol are critical for safety.

Replace only with part number specified.

**B.** In addition to safety, other parts and assemblies are specified for conformance with regulations applying to spurious radiation. These must also be replaced only with specified replacements.

Examples: RF converters, RF cables, noise blocking capacitors, and noise blocking filters, etc.

**C.** Use specified internal wiring. Note especially:

- 1) Wires covered with PVC tubing
- 2) Double insulated wires
- 3) High voltage leads

**D.** Use specified insulating materials for hazardous live parts. Note especially:

- 1) Insulation Tape
- 2) PVC tubing
- 3) Spacers
- 4) Insulators for transistors.

**E.** When replacing AC primary side components (transformers, power cord, etc.), wrap ends of wires securely about the terminals before soldering.

**F.** Observe that the wires do not contact heat producing parts (heatsinks, oxide metal film resistors, fusible resistors, etc.)

**G.** Check that replaced wires do not contact sharp edged or pointed parts.

**H.** When a power cord has been replaced, check that 5~6 kg of force in any direction will not loosen it.

**I.** Also check areas surrounding repaired locations.

**J.** Use care that foreign objects (screws, solder droplets, etc.) do not remain inside the set.

**K.** Crimp type wire connector

The power transformer uses crimp type connectors which connect the power cord and the primary side of the transformer. When replacing the transformer, follow these steps carefully and precisely to prevent shock hazards.

Replacement procedure

1) Remove the old connector by cutting the wires at a point close to the connector.

Important: Do not re-use a connector (discard it).

2) Strip about 15 mm of the insulation from the ends of the wires. If the wires are stranded, twist the strands to avoid frayed conductors.

3) Align the lengths of the wires to be connected. Insert the wires fully into the connector.

4) Use the crimping tool to crimp the metal sleeve at the center position. Be sure to crimp fully to the complete closure of the tool.

**L.** When connecting or disconnecting the internal connectors, first, disconnect the AC plug from the AC supply outlet.

## Safety Check after Servicing

Examine the area surrounding the repaired location for damage or deterioration. Observe that screws, parts and wires have been returned to original positions. Afterwards, perform the following tests and confirm the specified values in order to verify compliance with safety standards.

### 1. Clearance Distance

When replacing primary circuit components, confirm specified clearance distance ( $d$ ) and ( $d'$ ) between soldered terminals, and between terminals and surrounding metallic parts. (See Fig. 1)

**Table 1 : Ratings for selected area**

AC Line Voltage	Region	Clearance Distance ( $d$ ) ( $d'$ )
110 to 130 V	USA or CANADA	$\geq 3.2$ mm (0.126 inches)

**Note:** This table is unofficial and for reference only. Be sure to confirm the precise values.

### 2. Leakage Current Test

Confirm the specified (or lower) leakage current between B (earth ground, power cord plug prongs) and externally exposed accessible parts (RF terminals, antenna terminals, video and audio input and output terminals, microphone jacks, earphone jacks, etc.) is lower than or equal to the specified value in the table below.

#### Measuring Method : (Power ON)

Insert load Z between B (earth ground, power cord plug prongs) and exposed accessible parts. Use an AC voltmeter to measure across both terminals of load Z. See Fig. 2 and following table.

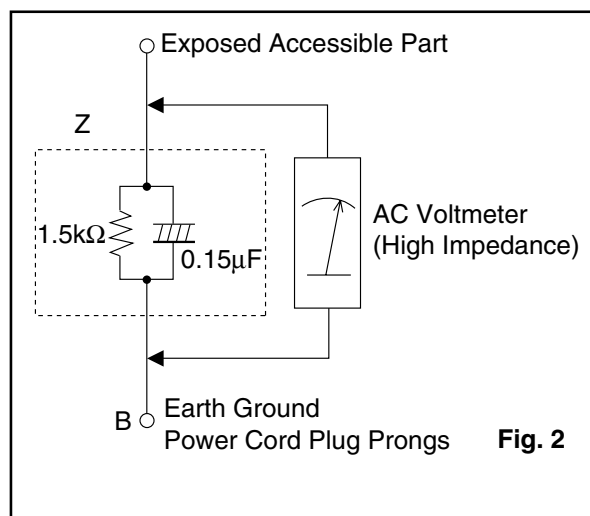
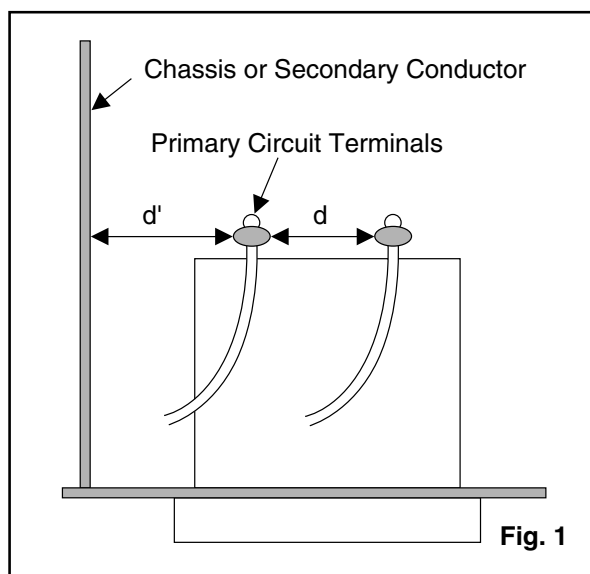

**Table 2 : Leakage current ratings for selected areas**

AC Line Voltage	Region	Load Z	Leakage Current ( $i$ )	Earth Ground (B) to:
110 to 130 V	USA	0.15 $\mu$ F CAP. & 1.5k $\Omega$ RES. connected in parallel	$i \leq 0.5$ mA rms	Exposed accessible parts

**Note:** This table is unofficial and for reference only. Be sure to confirm the precise values.

# STANDARD NOTES FOR SERVICING

## Circuit Board Indications

- a. The output pin of the 3 pin Regulator ICs is indicated as shown.

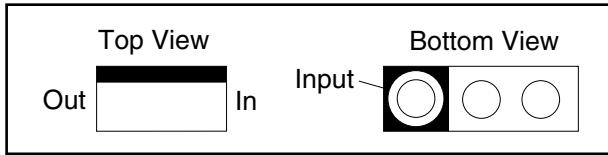

- b. For other ICs, pin 1 and every fifth pin are indicated as shown.

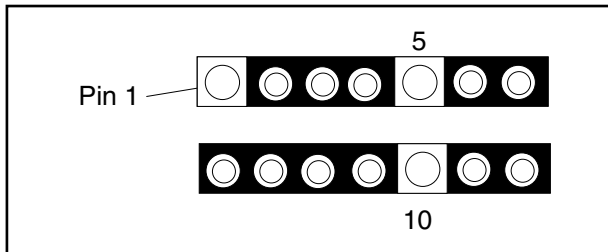

- c. The 1st pin of every male connector is indicated as shown.

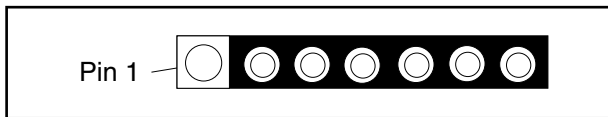

## How to Remove / Install Flat Pack-IC

### 1. Removal

#### With Hot-Air Flat Pack-IC Desoldering Machine:

- (1) Prepare the hot-air flat pack-IC desoldering machine, then apply hot air to the Flat Pack-IC (about 5 to 6 seconds). (Fig. S-1-1)

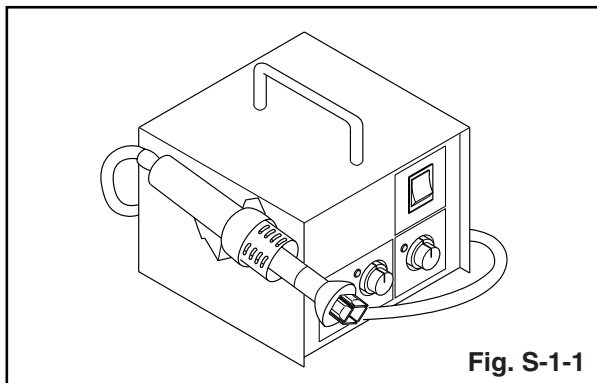

- (2) Remove the flat pack-IC with tweezers while applying the hot air.
- (3) Bottom of the flat pack-IC is fixed with glue to the CBA; when removing entire flat pack-IC, first apply soldering iron to center of the flat pack-IC and heat up. Then remove (glue will be melted). (Fig. S-1-6)
- (4) Release the flat pack-IC from the CBA using tweezers. (Fig. S-1-6)

### Caution:

1. Do not supply hot air to the chip parts around the flat pack-IC for over 6 seconds because damage to the chip parts may occur. Put masking tape around the flat pack-IC to protect other parts from damage. (Fig. S-1-2)
2. The flat pack-IC on the CBA is affixed with glue, so be careful not to break or damage the foil of each pin or the solder lands under the IC when removing it.

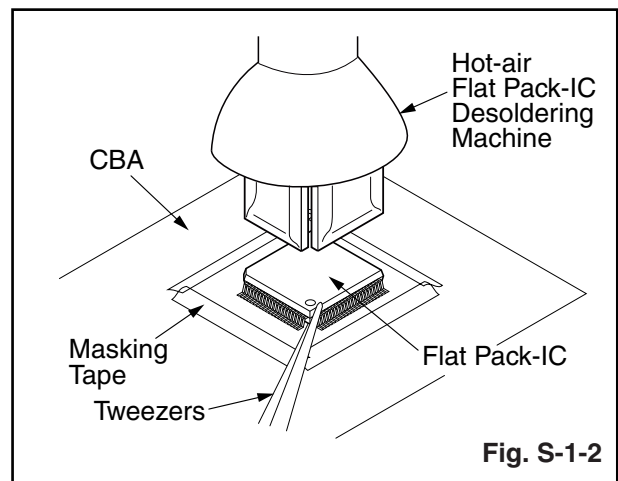



### With Soldering Iron:

- (1) Using desoldering braid, remove the solder from all pins of the flat pack-IC. When you use solder flux which is applied to all pins of the flat pack-IC, you can remove it easily. (Fig. S-1-3)

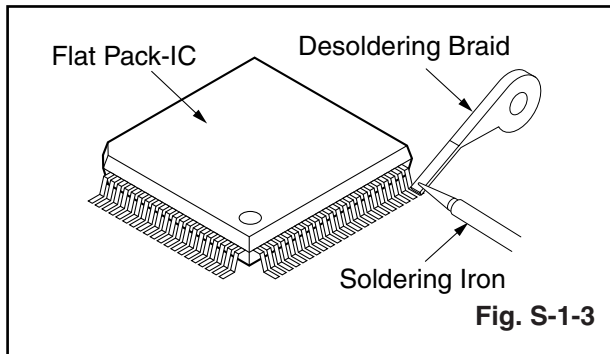

- (2) Lift each lead of the flat pack-IC upward one by one, using a sharp pin or wire to which solder will not adhere (iron wire). When heating the pins, use a fine tip soldering iron or a hot air desoldering machine. (Fig. S-1-4)

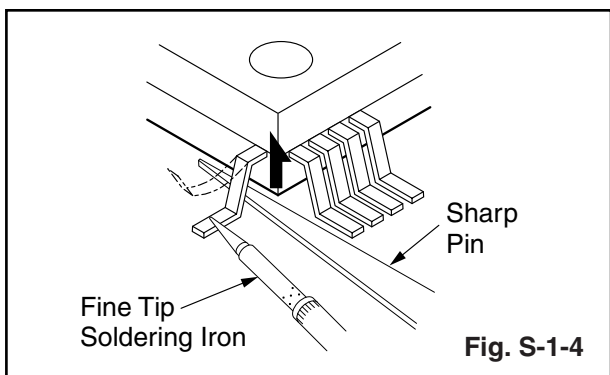

- (3) Bottom of the flat pack-IC is fixed with glue to the CBA; when removing entire flat pack-IC, first apply soldering iron to center of the flat pack-IC and heat up. Then remove (glue will be melted). (Fig. S-1-6)
- (4) Release the flat pack-IC from the CBA using tweezers. (Fig. S-1-6)

### With Iron Wire:

- (1) Using desoldering braid, remove the solder from all pins of the flat pack-IC. When you use solder flux which is applied to all pins of the flat pack-IC, you can remove it easily. (Fig. S-1-3)
- (2) Affix the wire to a workbench or solid mounting point, as shown in Fig. S-1-5.
- (3) While heating the pins using a fine tip soldering iron or hot air blower, pull up the wire as the solder melts so as to lift the IC leads from the CBA contact pads as shown in Fig. S-1-5.
- (4) Bottom of the flat pack-IC is fixed with glue to the CBA; when removing entire flat pack-IC, first apply

soldering iron to center of the flat pack-IC and heat up. Then remove (glue will be melted). (Fig. S-1-6)

- (5) Release the flat pack-IC from the CBA using tweezers. (Fig. S-1-6)

### Note:

When using a soldering iron, care must be taken to ensure that the flat pack-IC is not being held by glue. When the flat pack-IC is removed from the CBA, handle it gently because it may be damaged if force is applied.

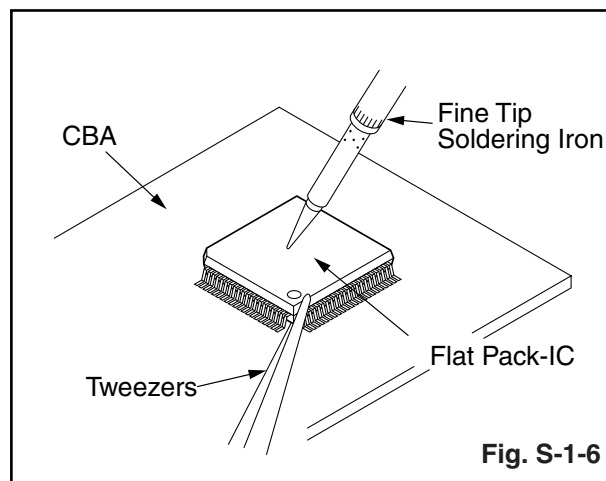
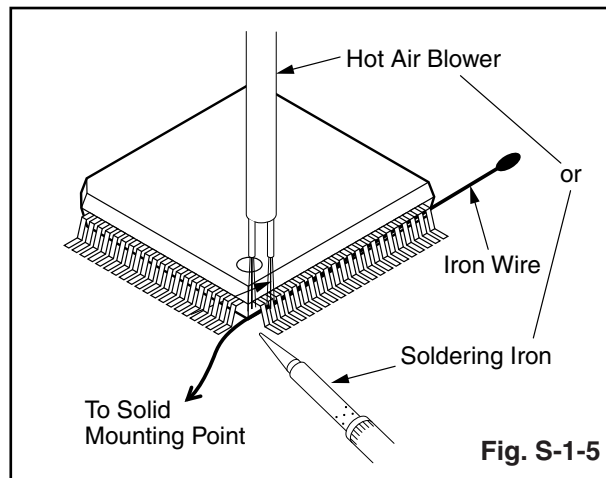

## 2. Installation

- (1) Using desoldering braid, remove the solder from the foil of each pin of the flat pack-IC on the CBA so you can install a replacement flat pack-IC more easily.
- (2) The "●" mark on the flat pack-IC indicates pin 1. (See Fig. S-1-7.) Be sure this mark matches the 1 on the PCB when positioning for installation. Then pre-solder the four corners of the flat pack-IC. (See Fig. S-1-8.)
- (3) Solder all pins of the flat pack-IC. Be sure that none of the pins have solder bridges.

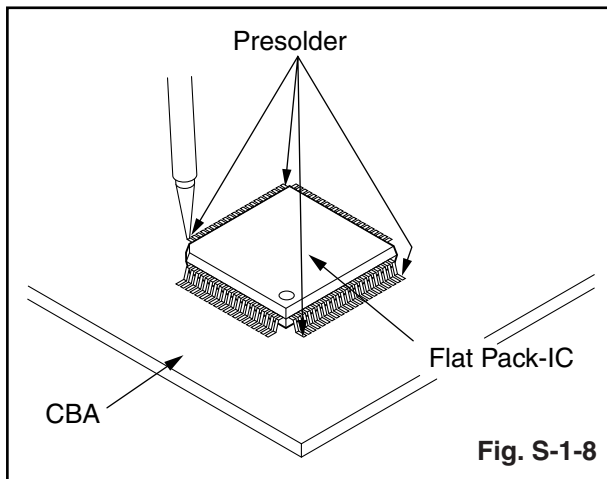
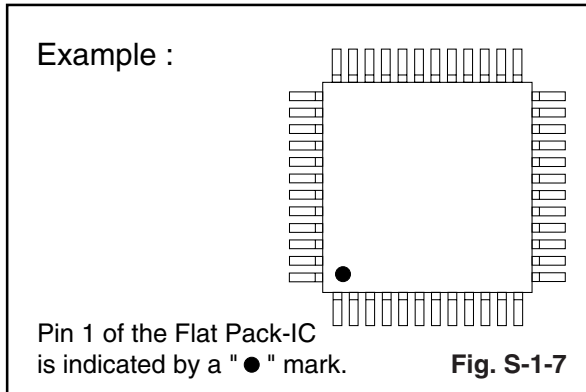

## Instructions for Handling Semiconductors

Electrostatic breakdown of the semiconductors may occur due to a potential difference caused by electrostatic charge during unpacking or repair work.

### 1. Ground for Human Body

Be sure to wear a grounding band ( $1M\Omega$ ) that is properly grounded to remove any static electricity that may be charged on the body.

### 2. Ground for Workbench

Be sure to place a conductive sheet or copper plate with proper grounding ( $1M\Omega$ ) on the workbench or other surface, where the semiconductors are to be placed. Because the static electricity charge on clothing will not escape through the body grounding band, be careful to avoid contacting semiconductors with your clothing.

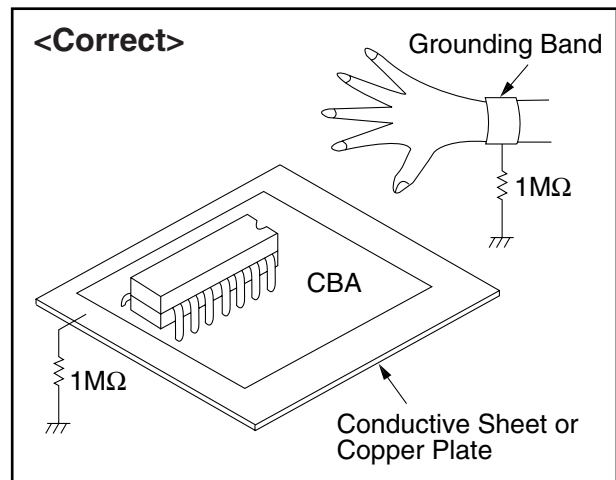
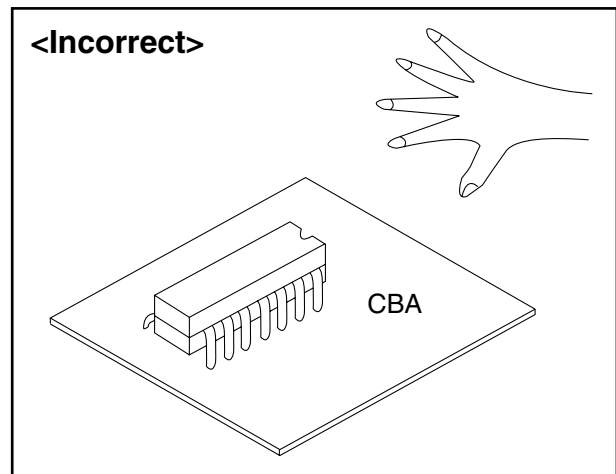

# CABINET DISASSEMBLY INSTRUCTIONS

## 1. Disassembly Flowchart

This flowchart indicates the disassembly steps for the cabinet parts, and the CBA in order to gain access to item(s) to be serviced. When reassembling, follow the steps in reverse order. Bend, route and dress the cables as they were.

### Caution !

When removing the CRT, be sure to discharge the Anode Lead of the CRT with the CRT Ground Wire before removing the Anode Cap.

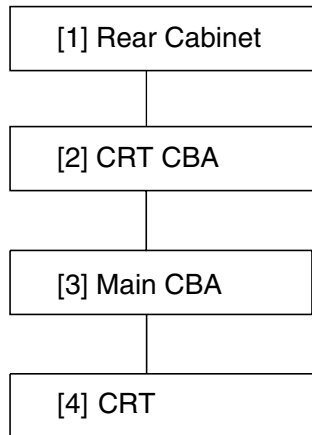

## 2. Disassembly Method

Step/ Loc. No.	Part	Removal		
		Fig. No	Remove/*unlock/ release/unplug/ unclamp/desolder	Note
[1]	Rear Cabinet	1,2	7(S-1), 1(S-2), 3(S-4)	1
[2]	CRT CBA	4,5	CN1501	2
[3]	Main CBA	3,5	CN571, CN801, CN802, CN691, Anode Cap	3
[4]	CRT	4	4(S-3)	4

↓            ↓            ↓            ↓            ↓  
 (1)        (2)        (3)            (4)            (5)

### Note:

- (1) Order of steps in procedure. When reassembling, follow the steps in reverse order. These numbers are also used as the Identification (location) No. of parts in figures.
- (2) Parts to be removed or installed.
- (3) Fig. No. showing procedure of part location
- (4) Identification of part to be removed, unhooked, unlocked, released, unplugged, unclamped, or desoldered.  
S=Screw, P=Spring, L=Locking Tab, CN=Connector, \*=Unhook, Unlock, Release, Unplug, or Desolder  
2(S-2) = two Screws (S-2)
- (5) Refer to the following "Reference Notes in the Table."

### Reference Notes in the Table

1. Removal of the Rear Cabinet. Remove screws 7(S-1), 1(S-2) and 3(S-4) then slide the Rear Cabinet backward.
2. Removal of the CRT CBA. Disconnect CN1501 then pull the CRT CBA backward.

### Caution !

Discharge the Anode Lead of the CRT with the CRT Ground Wire before removing the Anode Cap.

3. Removal of the Main CBA. First, disconnect CN571, CN801, CN802, and CN691 on the Main CBA. Second, remove Anode Cap. then slide the Main CBA backward.
4. Removal of the CRT. Remove screws 4(S-3) then slide the CRT backward.

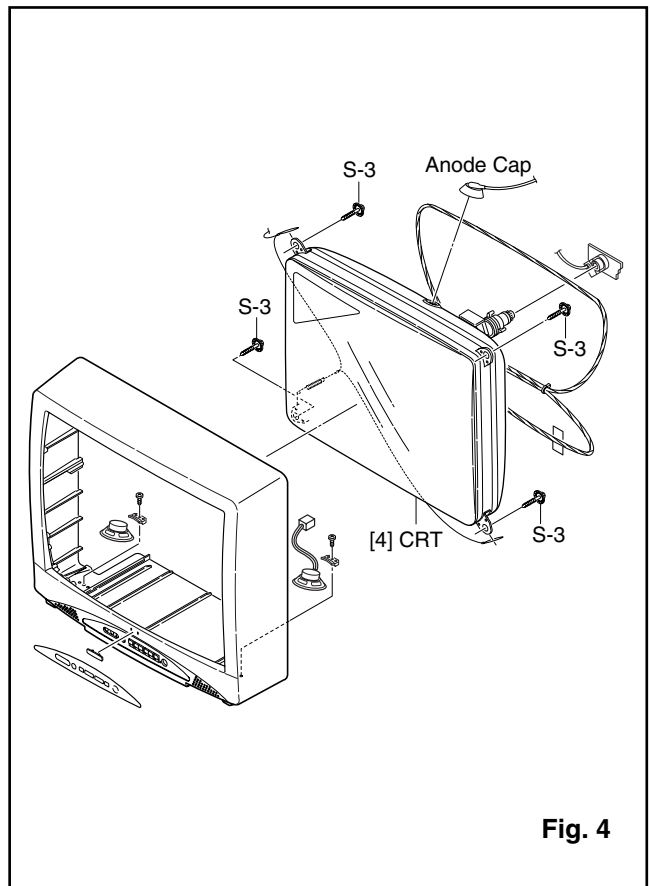
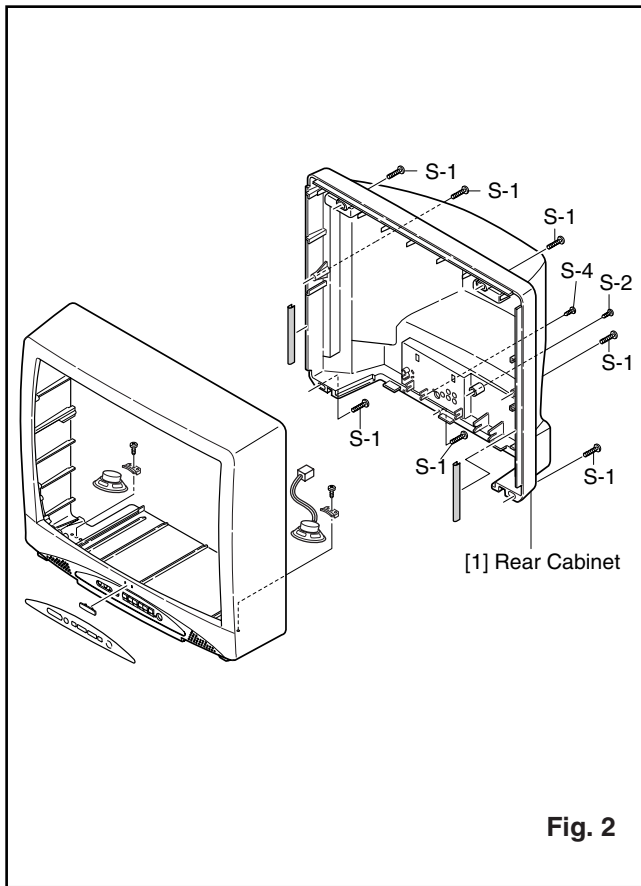
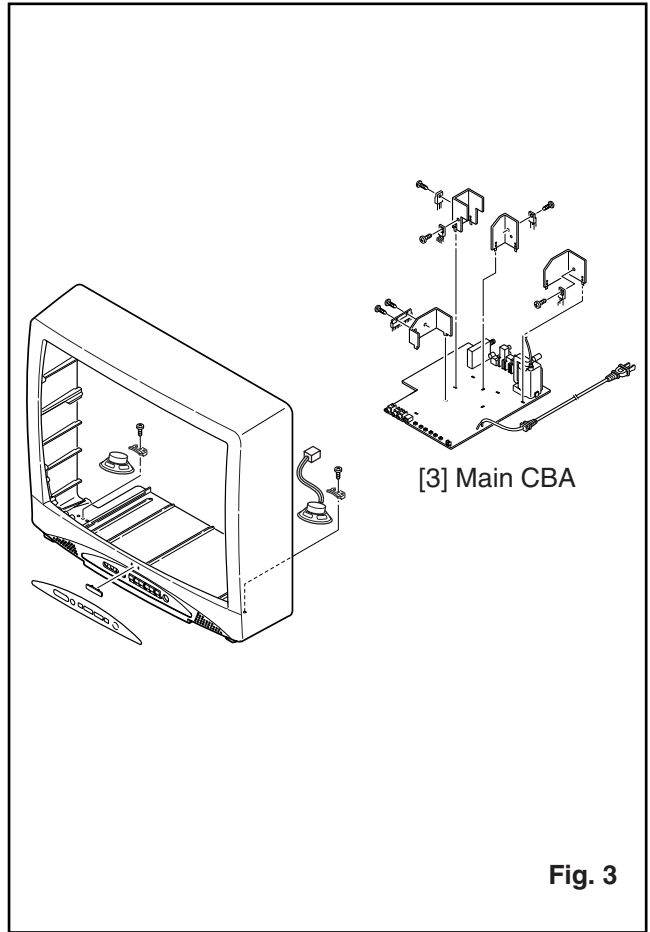
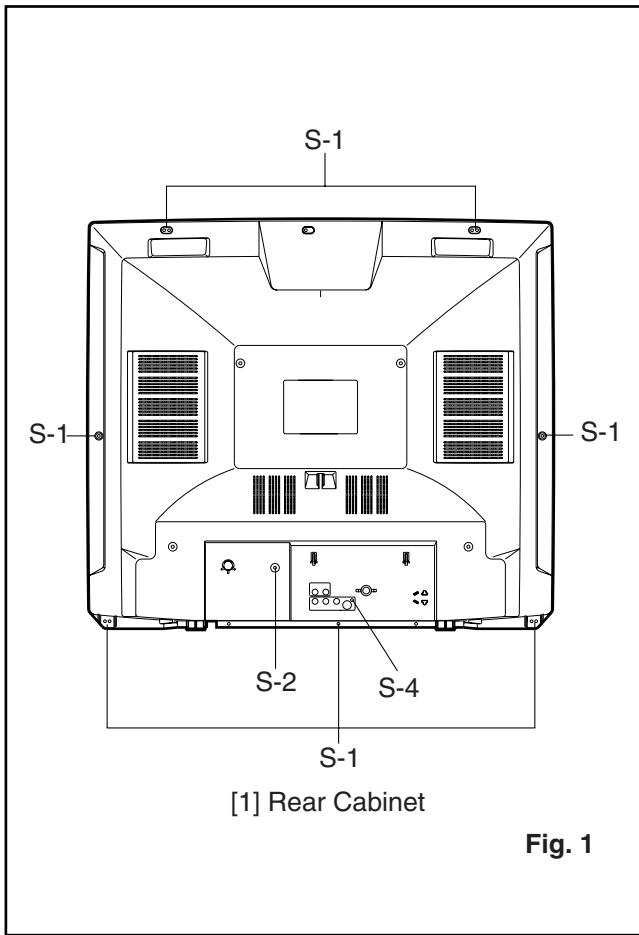

# TV Cable Wiring Diagram

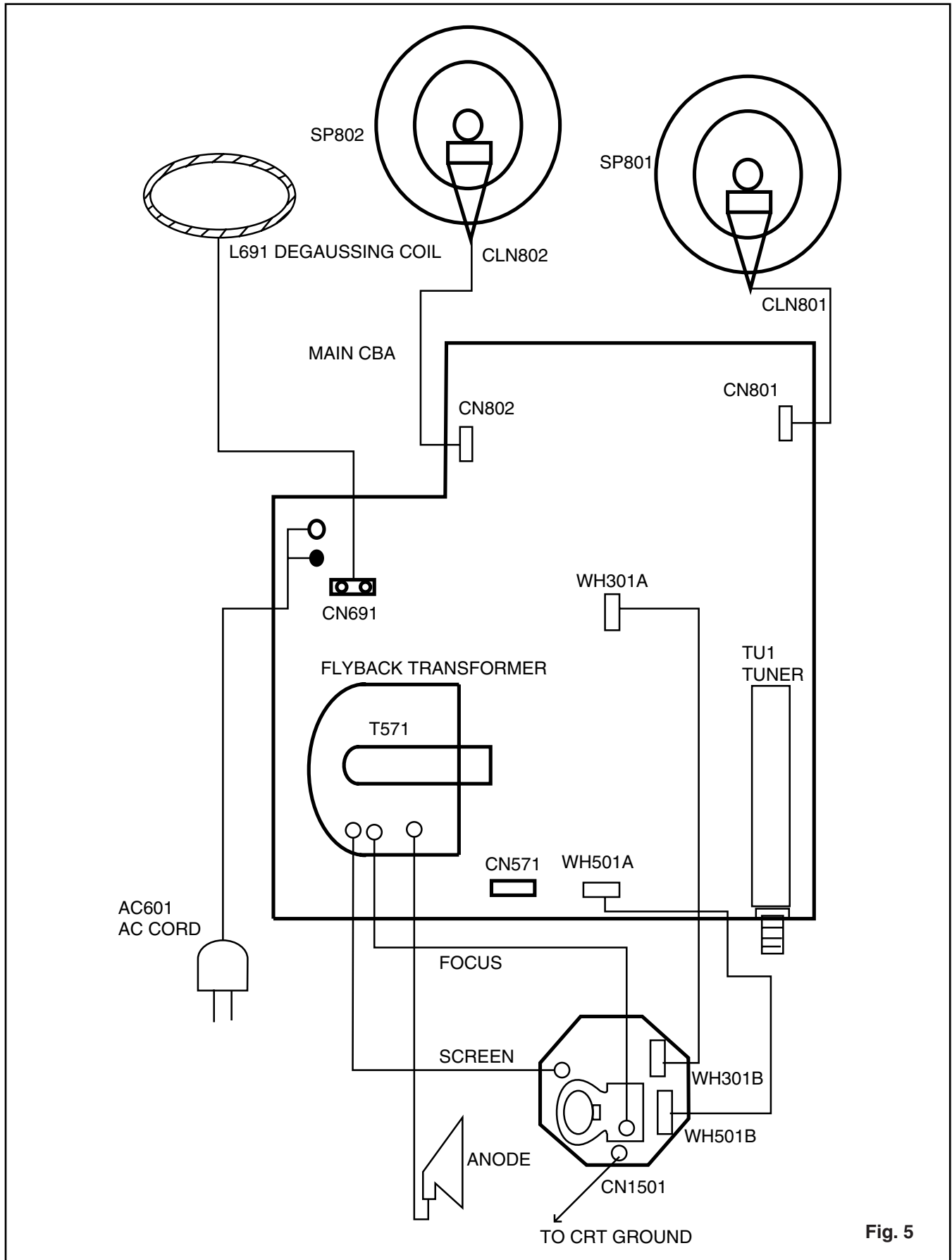

# ELECTRICAL ADJUSTMENT INSTRUCTIONS

## General Note:

"CBA" is abbreviation for "Circuit Board Assembly."

## NOTE:

Electrical adjustments are required after replacing circuit components and certain mechanical parts. It is important to perform these adjustments only after all repairs and replacements have been completed.

Also, do not attempt these adjustments unless the proper equipment is available.

## Test Equipment Required

1. NTSC Pattern Generator (Color Bar W/White Window, Red Color, Dot Pattern, Gray Scale, Monoscope, Multi-Burst)
2. DC Voltmeter
3. Oscilloscope: Dual-trace with 10:1 probe, V-Range:0.001~50V/Div, F-Range: DC~AC-60MHz
4. Plastic Tip Driver
5. Remote control unit: Part No. N0138UD or N0139UD
6. DC power supply 13.2V/5A

## How to make Service remote control unit:

1. Prepare normal remote control unit. (Part No. N0138UD or N0139UD) Remove 3 Screws from the back lid. (Fig. 1-1)
2. Added J1 (Jumper Wire) to the remote control CBA. (Fig. 1-2)

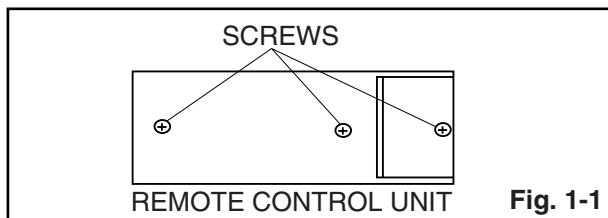

Fig. 1-1

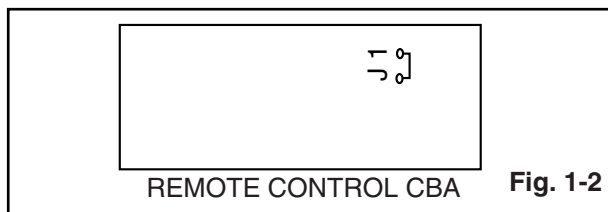

Fig. 1-2

## Notes:

1. The service remote control unit that be made in above method is usable in the electrical adjustment of the following models.  
SRT2313/2319, SRT2213B/2219B, SRT2227X, SRT2223X, SRT2223B, SRT2232X, SRT2220P, SRT4127P
2. The attached remote control unit can not be used as service remote control unit.

## How to set up the service mode:

### Service mode:

1. Use the service remote control unit.
2. Turn the power on. (Use main power on the TV unit.)
3. Press "SLEEP" button on the service remote control unit. Version of micro computer will display on the CRT. (Ex: 054-0.05)
4. Check the display on the lower left is "3815" and if it is not "3815," set it at "3815" according to "2. Initial Setting."

## 1. +B Adjustment

**Purpose:** To obtain correct operation.

**Symptom of Misadjustment:** The picture is dark and the unit does not operate correctly.

Test Point	Adj. Point	Mode	Input
TP601(+B) TP300(GND)	VR661	---	---
<b>Tape</b>	<b>M. EQ.</b>	<b>Spec.</b>	
---	DC Voltmeter	+132±0.5V DC.	

**Note:** TP601, TP300(GND), VR661 --- Main CBA

1. Connect DC Volt Meter to TP601 and TP300(GND).
2. Adjust VR661 so that the voltage of TP601 becomes +132±0.5V DC.

## 2. Initial Setting

### General

1. Enter the Service mode. (See page 5-1)
2. Press "VOL ▼" button on the service remote control unit. Display changes "C/D," "7F," "LANGUAGE," "ACCESS CODE," "SOUND TYPE," "VIDEO TONE," "FM MODE," "V-OUT," "VIDEO," "AV MEMO," "STABLE SOUND," "FILTER," "300," and "YUV MEMORY" cyclically when "VOL ▼" button is pressed.
3. To set the following each data value, press "CH ▲ / ▼" buttons on the service remote control unit.

**7F --- Set to "FF."**

**LANGUAGE --- Set to "SPA."**

**ACCESS CODE --- Set to "ON."**

**SOUND TYPE --- Set to "MTS."**

**VIDEO TONE --- Set to "ON."**

**FM-MODE --- Set to "OFF."**

**V-OUT --- Set to "OFF."**

**VIDEO --- Set to "V1/V2."**

**AV MEMO --- Set to "ON."**

**STABLE SOUND --- Set to "OFF."**

**FILTER --- Set to "ON."**

**Adjusting the monitoring time --- Set to "500."**

**YUV MEMORY --- Set to "OFF."**

## 3. AV Memory Setting data

### General

1. Enter the Service mode. (See page 5-1)
2. When "AV MEMORY" setting to "ON" (refer to "2-1. Setting for 7F, CHROMA, LANGUAGE, STEREO TYPE, ACCESS CODE, STABLE SOUND, COMB FILTER, COMPONENT and AV MEMORY data Values"), press "VOL ▲" button on the service remote control unit. Display changes "SPORT CNT," "SPORT CLR," "SPORT SRP," "NEWS CNT," "NEWS CLR," "NEWS SRP," "MOVIE CNT," "MOVIE CLR," and "MOVIE SRP" cyclically when "VOL ▲" button is pressed.
3. To set the following each data value, press "CH ▲ / ▼" buttons on the service remote control unit.

**SPORT CNT--- Set to "48."**

**SPORT CLR--- Set to "30."**

**SPORT SRP--- Set to "34."**

**NEWS CNT--- Set to "39."**

**NEWS CLR--- Set to "30."**

**NEWS SRP--- Set to "28."**

**MOVIE CNT--- Set to "43."**

**MOVIE CLR--- Set to "26."**

**MOVIE SRP--- Set to "24."**

## 4. Setting for BRIGHT, CONTRAST, COLOR, TINT and SHARPNESS data Values

### General

1. Enter the Service mode. (See page 5-1)
2. Press "MENU" button on the service remote control unit. Display changes "BRT," "CNT," "CLR," "S-CLR," "C-CLR," "TNT," "V-TNT," "S-TNT," "C-TNT," "SHARP," "S-SRP," and "C-SRP" cyclically when "MENU" button is pressed.

### CNT

1. Press "MENU" button on the service remote control unit. Then select "CONTRAST" (CNT) display.
2. Press "CH ▲/▼" buttons on the service remote control unit so that the value of "CONTRAST" (CNT) becomes 84.

### CLR

1. Press "MENU" button on the service remote control unit. Then select "COLOR" (CLR) display.
2. Press "CH ▲/▼" buttons on the service remote control unit so that the value of "COLOR" (CLR) becomes 56.

### S-CLR

1. Press "MENU" button on the service remote control unit. Then select "S-COLOR" (S-CLR) display.
2. Press "CH ▲/▼" buttons on the service remote control unit so that the value of "S-COLOR" (S-CLR) becomes 56.

### C-CLR

1. Press "MENU" button on the service remote control unit. Then select "COMPONENT COLOR" (C-CLR) display.
2. Press "CH ▲/▼" buttons on the service remote control unit so that the value of "COMPONENT COLOR" (C-CLR) becomes 56.

### TNT

1. Press "MENU" button on the service remote control unit. Then select "TINT" (TNT) display.
2. Press "CH ▲/▼" buttons on the service remote control unit so that the value of "TINT" (TNT) becomes 62.

### V-TNT

1. Press "MENU" button on the service remote control unit. Then select "V-TINT" (V-TNT) display.
2. Press "CH ▲/▼" buttons on the service remote control unit so that the value of "V-TINT" (V-TNT) becomes 62.

### S-TNT

1. Press "MENU" button on the service remote control unit. Then select "S-TINT" (S-TNT) display.
2. Press "CH ▲/▼" buttons on the service remote control unit so that the value of "S-TINT" (S-TNT) becomes 59.

### C-TNT

1. Press "MENU" button on the service remote control unit. Then select "COMPONENT TINT" (C-TNT) display.
2. Press "CH ▲/▼" buttons on the service remote control unit so that the value of "COMPONENT TINT" (C-TNT) becomes 58.

### SHARP

1. Press "MENU" button on the service remote control unit. Then select "SHARPNESS" (SHARP) display.
2. Press "CH ▲/▼" buttons on the service remote control unit and select "47."

### S-SRP

1. Press "MENU" button on the service remote control unit. Then select "S-SHARPNESS" (S-SRP) display.
2. Press "CH ▲/▼" buttons on the service remote control unit and select "47."

### C-SRP

1. Press "MENU" button on the service remote control unit. Then select "COMPONENT SHARPNESS" (C-SRP) display.
2. Press "CH ▲/▼" buttons on the service remote control unit and select "47."

**Note:** BRIGHT data value does not need to be adjusted at this moment.



## 5. Black Stretch Control Adjustment

**Purpose:** To show the fine black color.

**Symptom of Misadjustment:** Black color will not appear correctly.

**Note:** Use service remote control unit.

1. Enter the Service mode. (See page 5-1)
2. Press "6" button on the service remote control unit. "B-S" is indicated.
3. Press "CH ▲ / ▼" buttons on the service remote control unit so that display will change "OFF," "0," and "1." Then choose "B-S OFF."
4. Press "6" button on the service remote control unit. "B-S2" is indicated.
5. Press "CH ▲ / ▼" buttons on the service remote control unit so that display will change "0" and "1." Then choose "B-S2 0."
6. Turn the power off and on again, using the main power button on the TV unit.

## 6. Purity Check

1. Enter the Service mode. (See page 5-1)
2. Press "7" button on the remote control unit. Each time pressing 7" button on the remote control unit, display changes Red mode, Green mode, Blue mode, and White mode cyclically.
3. Select White mode.
4. Turn the power off and on again. (Main power button on the TV unit.)

## 7. SD Check Mode

1. Enter the Service mode. (See page 5-1)
2. Press "1" button on the remote control unit. The unit enter the SD-Check mode.
3. The unit starts selecting the added channel from first channel according to the memorized CH ADD/ DELL data and CATV/TV data in RAM.

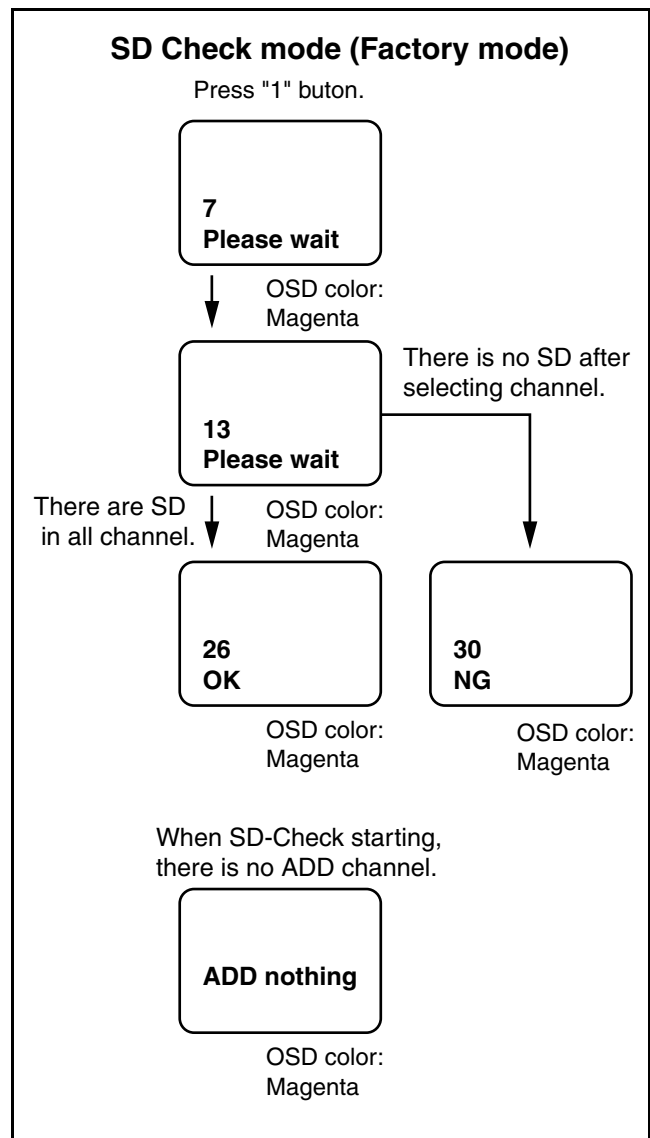

## 8. H. Position Adjustment

**Purpose:** To obtain correct horizontal position of screen image.

**Symptom of Misadjustment:** If H. Position is incorrect, horizontal position of image on the screen may not be properly displayed.

Test Point	Adj. Point	Mode	Input
---	CH ▲ / ▼ buttons	RF	Monoscope
<b>Tape</b>	<b>M. EQ.</b>	<b>Spec.</b>	
---	Monoscope	90±5%	

**Note:** Use service remote control unit

1. Operate the unit for at least 20 minutes.
2. Enter the Service mode. (See page 5-1)
3. Receive the monoscope pattern.
4. Press "8" button on the remote control unit. "H-P" is indicated.
5. Press "CH ▲/▼" buttons on the service remote control unit so that the monoscope pattern will be 90±5% of display size and the circle is round.
6. Turn the power off and on again. (Main power button on the TV unit.)

## 9. V. Size Adjustment

**Purpose:** To obtain correct vertical width of screen image.

**Symptom of Misadjustment:** If V. Size is incorrect, vertical size of image on the screen may not be properly displayed.

Test Point	Adj. Point	Mode	Input
---	CH ▲ / ▼ buttons	RF	Monoscope
<b>Tape</b>	<b>M. EQ.</b>	<b>Spec.</b>	
---	Monoscope	90±5%	

**Note:** Use service remote control unit.

1. Operate the unit for at least 20 minutes.
2. Enter the Service mode. (See page 5-1)
3. Receive the monoscope pattern.
4. Press "9" button on the service remote control unit and select "V-S" mode. (Display changes "V-S" and "V-P" cyclically when "9" button is pressed).
5. Press "CH ▲/▼" buttons on the service remote control unit so that the monoscope pattern will be 90±5% of display size and the circle is round.
6. Turn the power off and on again. (Main power button on the TV unit.)

## 10. V. Position Adjustment

**Purpose:** To obtain correct vertical width of screen image.

**Symptom of misadjustment:** If V. Position is incorrect, vertical height of image on the screen may not be properly displayed.

Test Point	Adj. Point	Mode	Input
---	CH ▲ / ▼ buttons	RF	Monoscope
<b>Tape</b>	<b>M. EQ.</b>	<b>Spec.</b>	
---	Monoscope	See below.	

**Note:** Use service remote control unit

1. Operate the unit for at least 20 minutes.
2. Enter the Service Mode. (See page 5-1)
3. Receive the monoscope pattern.
4. Press "9" button on the service remote control unit and select "V-P" mode. (Display change "V-S" and "V-P" cyclically when "9" button is pressed).
5. Press "CH ▲/▼" buttons on the service remote control unit so that the top and bottom of the monoscope pattern will be equal of each other.
6. Turn the power off and on again. (Main power button on the TV unit.)

## 11. U-Pedestal Adjustment

1. In VIDEO mode of V1, V2, or YUV, press "3" button on the service remote control unit and select "U-PED" mode. (Display changes "U-PED" and "V-PED" cyclically when "3" button is pressed).
2. Switch the VIDEO mode to YUV. (Refer to "2. Initial Setting.")
3. To select one appropriate value in "0" to "15," press "CH ▲ / ▼" buttons on the remote control unit.
4. Switch the VIDEO mode to previous mode.
5. Turn the power off and on again. (Main power button on the TV unit.)

## 12. V-Pedestal Adjustment

1. In VIDEO mode of V1, V2, or YUV, press "3" button on the service remote control unit and select "V-PED" mode. (Display changes "U-PED" and "V-PED" cyclically when "3" button is pressed).
2. Switch the VIDEO mode to YUV. (Refer to "2. Initial Setting.")
3. To select one appropriate value in "0" to "15," press "CH ▲ / ▼" buttons on the remote control unit.
4. Switch the input mode to previous mode.
5. Turn the power off and on again. (Main power button on the TV unit.)

## 13. Software Reset

To reset software, press "5" button on the remote control unit for at least 5 seconds after pressing "CH RETURN" button on the remote control unit.

## 14. H. Size Adjustment

**Purpose:** To obtain correct horizontal size of screen image.

**Symptom of Misadjustment:** If H. Size is incorrect, horizontal size of image on the screen may not be properly displayed.

Test Point	Adj. Point	Mode	Input
---	VR562	RF	Monoscope
Tape	M. EQ.	Spec.	
---	Monoscope	90±5%	

**Note:** Use service remote control unit

1. Operate the unit for at least 20 minutes.
2. Receive the Monoscope Pattern.
3. Adjust VR562 so that the monoscope pattern will be 90±5% of display size and circle is round.
4. Turn the Power off and on again. (Main power button on the TV unit.)

## 15. PIN Cushion Adjustment

**Purpose:** To obtain correct straight vertical line of screen image.

**Symptom of Misadjustment:** If H.Pin cushion is incorrect, vertical line of image on the screen may not be properly displayed.

Test Point	Adj. Point	Mode	Input
---	VR561	RF	Cross hatch
Tape	M. EQ.	Spec.	
---	Cross hatch		

**Note:** Use service remote control unit

1. Operate the unit for at least 20 minutes.
2. Receive the Cross hatch Pattern.
3. Adjust VR561 so that the cross hatch pattern will be straight line of display.
4. Turn the Power off and on again. (Main power button on the TV unit.)

## 16. Cut-off Adjustment

**Purpose:** To adjust the beam current of R, G, B, and screen voltage.

**Symptom of Misadjustment:** White color may be reddish, greenish or bluish.

Test Point	Adj. Point	Mode	Input
---	Screen-Control CH ▲ / ▼ buttons	RF	Black Raster
<b>Tape</b>	<b>M. EQ.</b>	<b>Spec.</b>	
---	Pattern Generator	See Reference Notes below.	

**Figure**

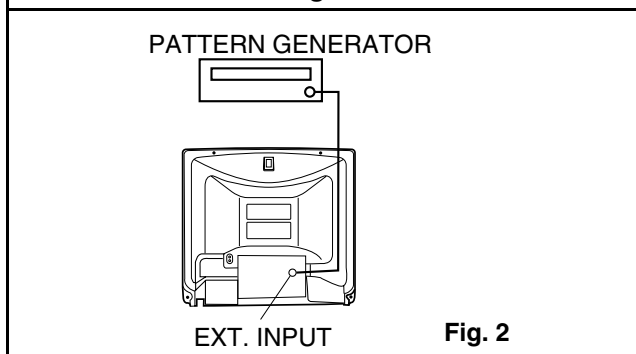

**Fig. 2**

**Note:** Screen Control FBT --- Main CBA  
F.B.T= Fly Back Transformer  
Use service remote control unit

1. Degauss the CRT and allow CRT to operate for 20 minutes before starting the alignment.
2. Input the Black Raster Signal from RF Input.
3. Enter the Service mode. (See page 5-1)
4. Press "VOL ▼" button on the service remote control unit and select "C/D" mode. (Display changes "C/D," "7F," "LANGUAGE," "ACCESS CODE," "SOUND TYPE," "VIDEO TONE," "FM MODE," "V-OUT," "VIDEO," "AV MEMO," "STABLE SOUND," "FILTER," "500," and "YUV MEMORY" cyclically when "VOL ▼" button is pressed.) then press "1." The display will momentarily show "CUT OFF R" (R= Red). Now there should be a horizontal line across the center of the picture tube. If needed gradually turn the screen control on the fly-back, clockwise until the horizontal line appears. Adjust the Red Cut off by pressing the "CH ▲/▼" buttons. Proceed to Step 5 when the Red Cut off adjustment is done.
5. Press the "2" button. The display will momentarily show "CUT OFF G" (G=Green). Adjust the Green Cut off by pressing the "CH ▲/▼" buttons. Proceed to step 6 when the Green Cut off adjustment is done.
6. Press the "3" button. The display will momentarily show "CUT OFF B" (B=Blue). Adjust the Blue cut off by pressing the "CH ▲/▼" buttons. When done with steps 4, 5 and 6 the horizontal line should be pure white if not, then attempt the Cut off adjustment again.

## 17. White Balance Adjustment

**Purpose:** To mix red, green and blue beams correctly for pure white.

**Symptom of Misadjustment:** White becomes bluish or reddish.

Test Point	Adj. Point	Mode	Input
Screen	CH ▲ / ▼ buttons	RF	White Raster (APL 100%)
<b>Tape</b>	<b>M. EQ.</b>	<b>Spec.</b>	
---	Pattern Generator, Color analyzer	See below	

**Figure**

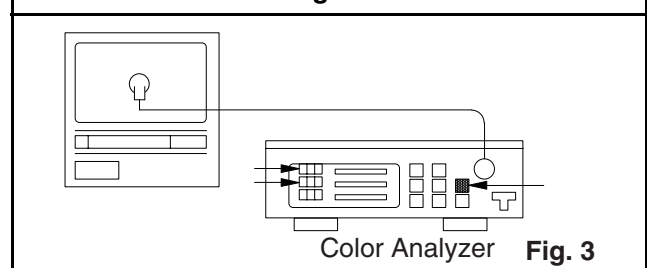

**Fig. 3**

**Note:** Use service remote control unit

1. Operate the unit more than 20 minutes.
2. Face the unit to east. Degauss the CRT using Degaussing Coil.
3. Input the White Raster (APL 100%).
4. Set the color analyzer to the CHROMA mode and after zero point calibration, bring the optical receptor to the center on the tube surface (CRT).
5. Enter the Service mode. Press "VOL ▼" button on the service remote control unit and select "C/D" mode. (Display changes "C/D," "7F," "LANGUAGE," "ACCESS CODE," "SOUND TYPE," "VIDEO TONE," "FM MODE," "V-OUT," "VIDEO," "AV MEMO," "STABLE SOUND," "FILTER," "500," and "YUV MEMORY" cyclically when "VOL ▼" button is pressed.) then Press No. 8 button on the service remote control Unit.
6. Press No. 4 button on the service remote control unit for Red adjustment. Press NO. 5 button on the service remote control unit for Blue adjustment.
7. In each color mode, Press "CH ▲/▼" button to adjust the values of color.
8. Adjusting Red and Blue color so that the temperature becomes 9200K (x: 286 / y: 294)±3%.
9. At this time, Re-check that Horizontal line is white. If not, Re-adjust Cut-off Adjustment until the Horizontal Line becomes pure white.
10. Turn off and on again to return to normal mode. Receive APL 100% white signal and Check Chroma temperatures become 9200K (x: 286 / y: 294)±3%.

**Note:** Confirm that Cut Off Adj. is correct after this adjustment, and attempt Cut Off Adj. if needed.

## 18. Sub-Brightness Adjustment

**Purpose:** To get proper brightness.

**Symptom of Misadjustment:** If Sub-Brightness is incorrect, proper brightness cannot be obtained by adjusting the Brightness Control.

Test Point	Adj. Point	Mode	Input
---	CH ▲ / ▼ buttons	RF	IQW
<b>Tape</b>	<b>M. EQ.</b>	<b>Spec.</b>	
---	Pattern Generator	See below	
<b>Figure</b>			

**Note:** IQW Setup level --- 7.5 IRE

Use service remote control unit

1. Enter the Service mode. (See page 5-1)  
Then input IQW signal from RF Input.
2. Press "MENU" button on the service remote control unit and Select "BRT" mode. (Display changes "BRT," "CNT," "CLR," "S-CLR," "TNT," "V-TNT," "S-TNT," "SHARP," and "S-SRP" cyclically when "MENU" button is pressed). Press "CH ▲/▼" buttons so that the bar is just visible (See above figure).
3. Turn the power off and on again. (Main power button on the TV unit.)

## 19. Focus Adjustment

**Purpose:** Set the optimum Focus.

**Symptom of Misadjustment:** If Focus Adjustment is incorrect, blurred images are shown on the display.

Test Point	Adj. Point	Mode	Input
---	Focus Control	---	Monoscope
<b>Tape</b>	<b>M. EQ.</b>	<b>Spec.</b>	
---	Pattern Generator	See below	

**Note:** Focus VR (FBT) - Main CBA,  
FBT=Fly Back Transformer

1. Operate the unit more than 30 minutes.
2. Face the unit to the East and Degauss the CRT using Degaussing Coil.
3. Input the Monoscope Pattern.

4. Adjust the Focus Control on the FBT to obtain clear picture.

**The following adjustments normally are not attempted in the field. Only when replacing the CRT then adjust as a preparation.**

## 20. Purity Adjustment

**Purpose:** To obtain pure color.

**Symptom of Misadjustment:** If Color Purity Adjustment is incorrect, large areas of color may not be properly displayed.

Test Point	Adj. Point	Mode	Input
---	Deflection Yoke Purity Magnet	---	Red Color
<b>Tape</b>	<b>M. EQ.</b>	<b>Spec.</b>	
---	Pattern Generator	See below.	
<b>Figure</b>			

1. Set the unit facing east.
2. Operate the unit for over 30 minutes before adjusting.
3. Fully degauss the unit using an external degaussing coil.
4. Loosen the screw on the Deflection Yoke Clamper and pull the Deflection Yoke back away from the screen. (See Fig. 6)
5. Loosen the Ring Lock and adjust the Purity Magnets so that a red field is obtained at the center of the screen. Tighten Ring Lock. (See Fig. 5,6)
6. Slowly push the Deflection Yoke toward bell of CRT and set it where a uniform red field is obtained.
7. Tighten the clamp screw on the Deflection Yoke.

## 21. Convergence Adjustment

**Purpose:** To obtain proper convergence of red, green and blue beams.

**Symptom of Misadjustment:** If Convergence Adjustment is incorrect, the edge of white letters may have color edges.

Test Point	Adj. Point	Mode	Input
---	C.P. Magnet (RB), C.P. Magnet (RB-G), Deflection Yoke	---	Dot Pattern or Crosshatch
Tape	M. EQ.	Spec.	
---	Pattern Generator	See below.	

### Figures

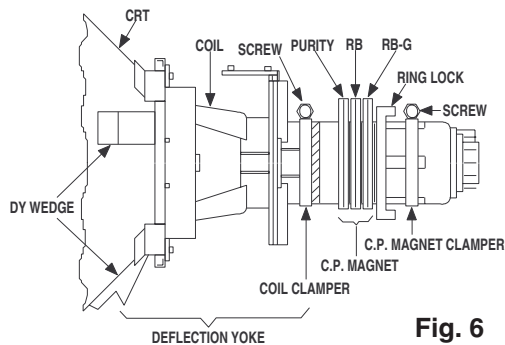

Fig. 6

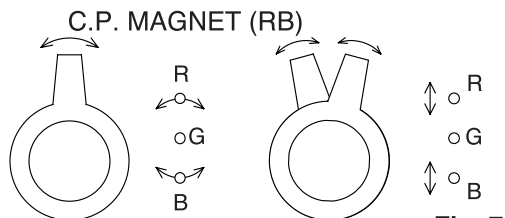

Fig. 7

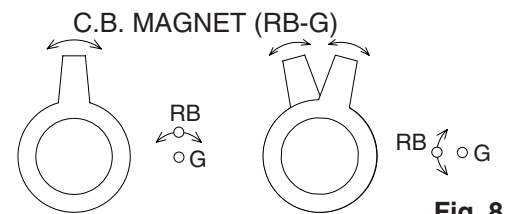
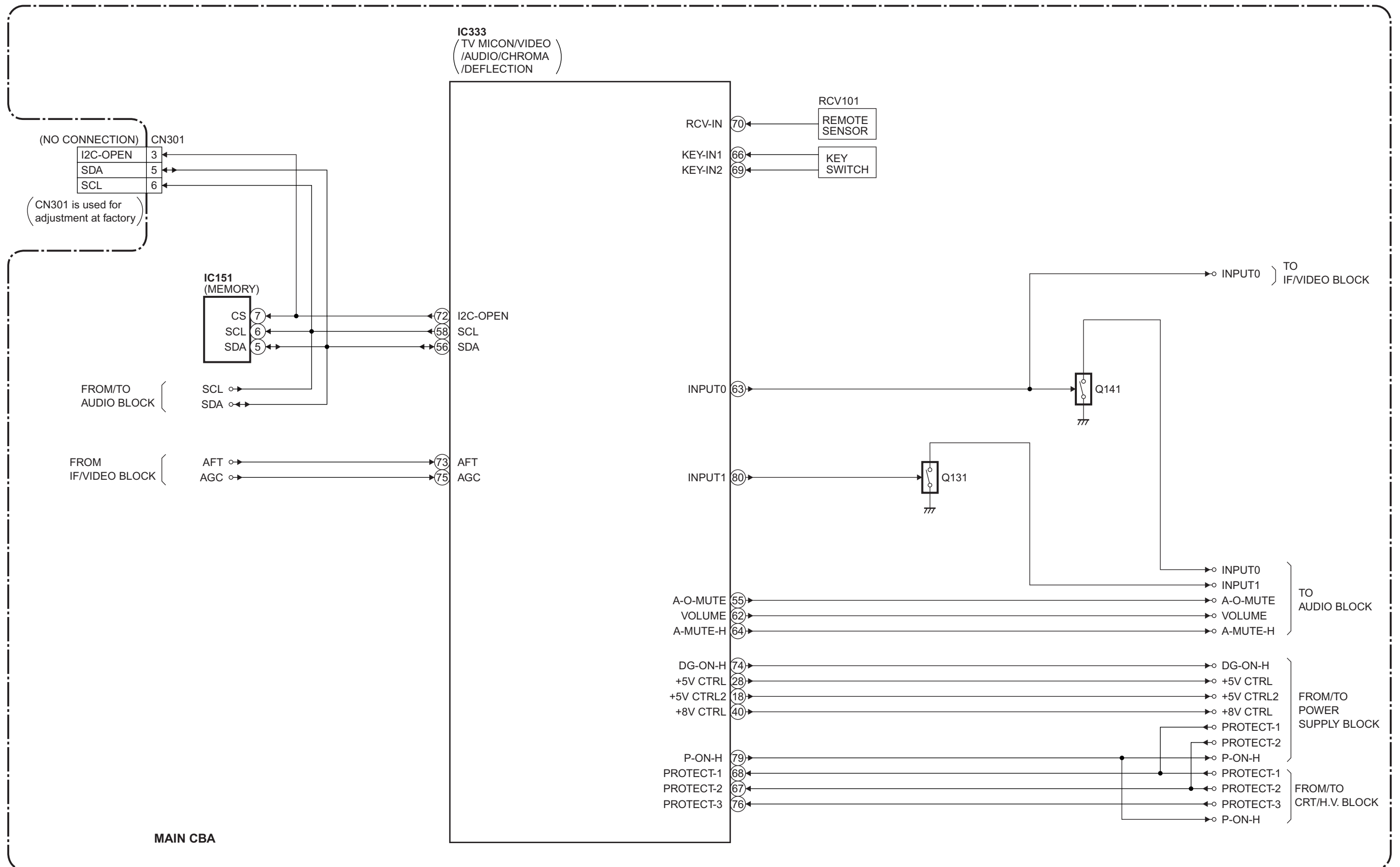

Fig. 8

1. Loosen the Ring Lock and align red with blue dots or Crosshatch at the center of the screen by rotating (RB) C.P. Magnets. (See Fig. 7)
2. Align red / blue with green dots at the center of the screen by rotating (RB-G) C.P. Magnet. (See Fig. 8)
3. Paintlock the C.P. Magnets after adjustment.
4. Remove the DY Wedges and slightly tilt the Deflection Yoke horizontally and vertically to obtain the best overall convergence.
5. Fix the Deflection Yoke by carefully inserting the DY Wedges between CRT and Deflection Yoke.

# BLOCK DIAGRAMS

## System Control Block Diagram



# IF/Video Block Diagram

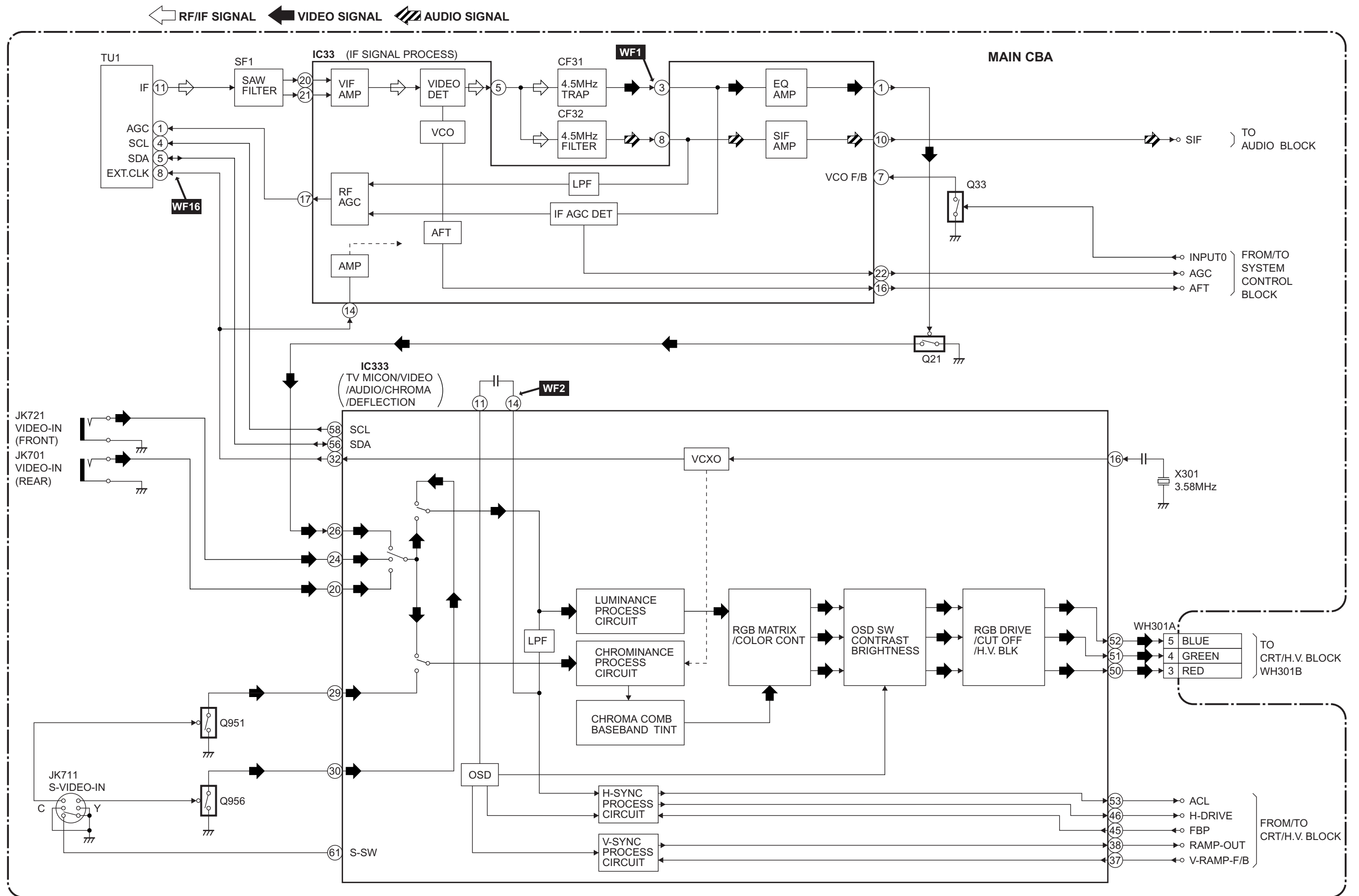



# Audio Block Diagram

 AUDIO SIGNAL

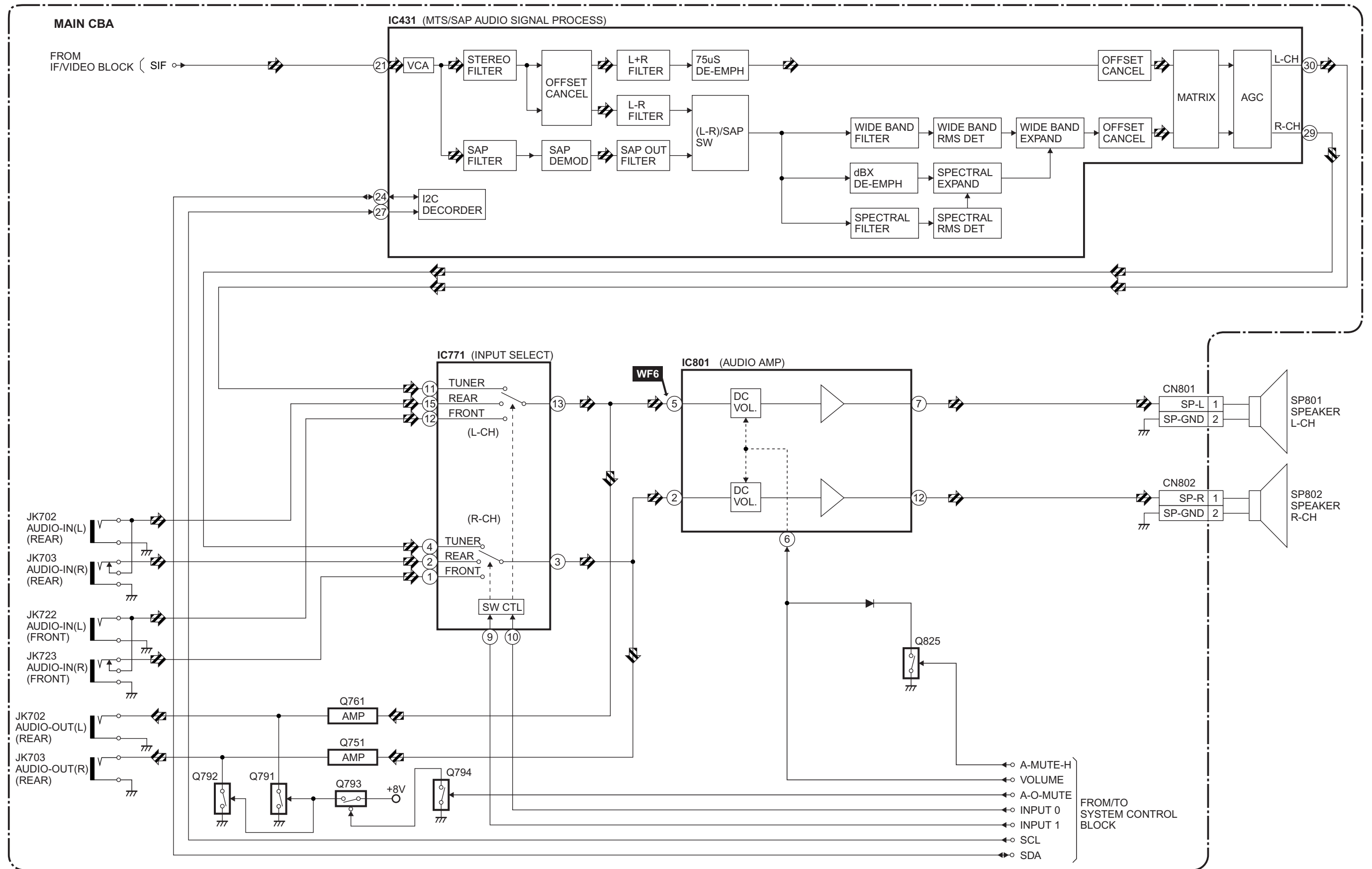

# CRT/H.V. Block Diagram

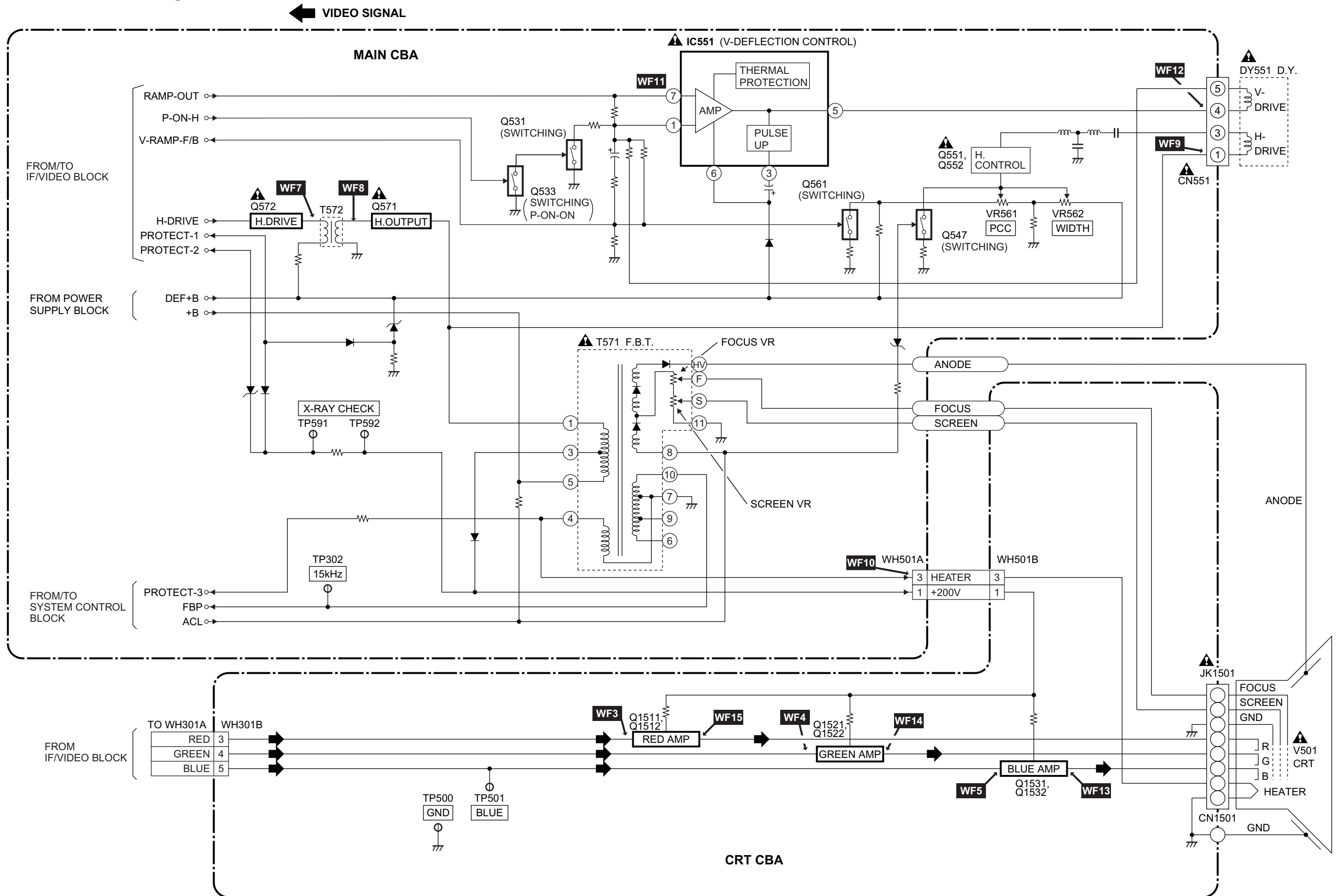

# Power Supply Block Diagram

**CAUTION !**

Fixed voltage ( or Auto voltage selectable ) power supply circuit is used in this unit. If Main Fuse (F601) is blown, check to see that all components in the power supply circuit are not defective before you connect the AC plug to the AC power supply. Otherwise it may cause some components in the power supply circuit to fail.

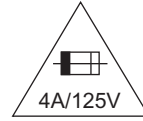

**CAUTION:** FOR CONTINUED PROTECTION AGAINST RISK OF FIRE, REPLACE ONLY WITH SAME TYPE 4 A, 125V FUSE.  
**ATTENTION:** UTILISER UN FUSIBLE DE RECHANGE DE MÊME TYPE DE 4A, 125V.

**NOTE :**  
 The voltage for parts in hot circuit is measured using hot GND as a common terminal.

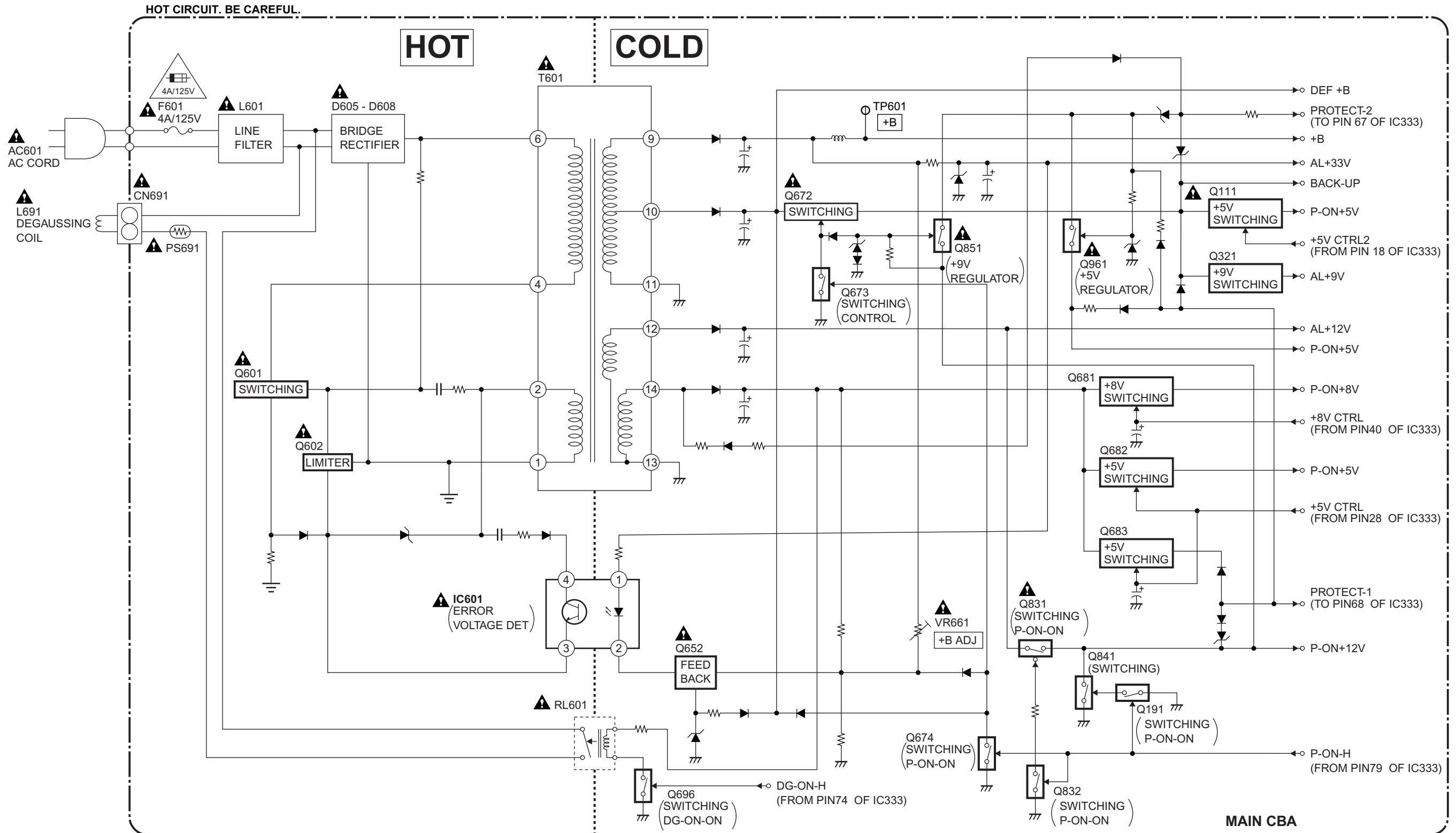

# SCHEMATIC DIAGRAMS / CBA'S AND TEST POINTS

## Standard Notes

Many electrical and mechanical parts in this chassis have special characteristics. These characteristics often pass unnoticed and the protection afforded by them cannot necessarily be obtained by using replacement components rated for higher voltage, wattage, etc. Replacement parts that have these special safety characteristics are identified in this manual and its supplements; electrical components having such features are identified by the mark "▲" in the schematic diagram and the parts list. Before replacing any of these components, read the parts list in this manual carefully. The use of substitute replacement parts that do not have the same safety characteristics as specified in the parts list may create shock, fire, or other hazards.

### Note:

1. Do not use the part number shown on these drawings for ordering. The correct part number is shown in the parts list, and may be slightly different or amended since these drawings were prepared.
2. All resistance values are indicated in ohms ( $K=10^3$ ,  $M=10^6$ ).
3. Resistor wattages are 1/4W or 1/6W unless otherwise specified.
4. All capacitance values are indicated in  $\mu F$  ( $P=10^{-6}\mu F$ ).
5. All voltages are DC voltages unless otherwise specified.

### Note of Capacitors:

ML --- Mylar Cap. PP --- Metallized Film Cap. SC --- Semiconductor Cap. L --- Low Leakage type

### Temperature Characteristics of Capacitors are noted with the following:

B ---  $\pm 10\%$  CH ---  $0\pm 60\text{ppm}/^\circ\text{C}$  CSL ---  $+350\sim -1000\text{ppm}/^\circ\text{C}$

### Tolerance of Capacitors are noted with the following:

Z ---  $+80\sim -20\%$

### Note of Resistors:

CEM --- Cement Res. MTL --- Metal Res. F --- Fuse Res.

### Capacitors and transistors are represented by the following symbols.

#### CBA Symbols

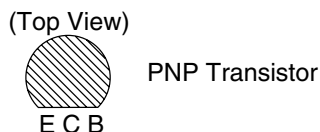
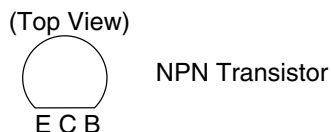
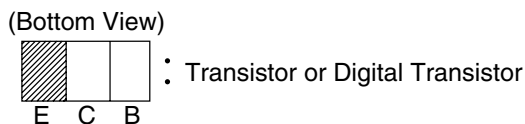
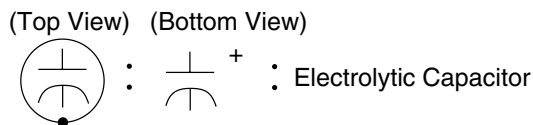

#### Schematic Diagram Symbols

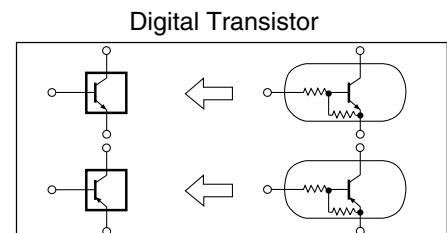

## LIST OF CAUTION, NOTES, AND SYMBOLS USED IN THE SCHEMATIC DIAGRAMS ON THE FOLLOWING PAGES:

1. **CAUTION:** FOR CONTINUED PROTECTION AGAINST RISK OF FIRE, REPLACE ONLY WITH SAME TYPE\_A,\_V FUSE.

**ATTENTION:** UTILISER UN FUSIBLE DE RECHANGE DE MÊME TYPE DE\_A,\_V.

### 2. CAUTION:

Fixed Voltage (or Auto voltage selectable) power supply circuit is used in this unit.

If Main Fuse (F601) is blown, first check to see that all components in the power supply circuit are not defective before you connect the AC plug to the AC power supply. Otherwise it may cause some components in the power supply circuit to fail.

### 3. Note:

(1) Do not use the part number shown on the drawings for ordering. The correct part number is shown in the parts list, and may be slightly different or amended since the drawings were prepared.

(2) To maintain original function and reliability of repaired units, use only original replacement parts which are listed with their part numbers in the parts list section of the service manual.

### 4. Wire Connectors

(1) Prefix symbol "CN" means "connector" (can disconnect and reconnect).

(2) Prefix symbol "CL" means "wire-solder holes of the PCB" (wire is soldered directly).

5. **Note:** Mark "●" is a leadless (chip) component.

### 6. Voltage indications on the schematics are as shown below:

Plug the TV power cord into a standard AC outlet.:

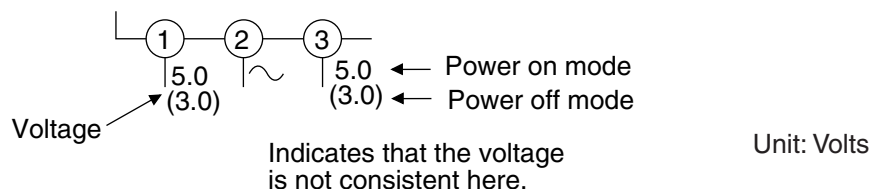

### 7. How to read converged lines

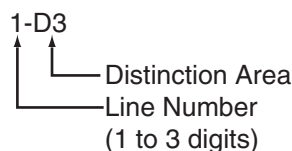

Examples:

1. "1-D3" means that line number "1" goes to area "D3".

2. "1-B1" means that line number "1" goes to area "B1".

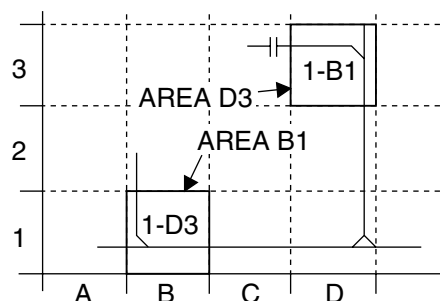

### 8. Test Point Information

⊙ : Indicates a test point with a jumper wire across a hole in the PCB.

□→ : Used to indicate a test point with a component lead on foil side.

⊘ : Used to indicate a test point with no test pin.

● : Used to indicate a test point with a test pin.



# Main 2/4 Schematic Diagram

VIDEO SIGNAL

AUDIO SIGNAL

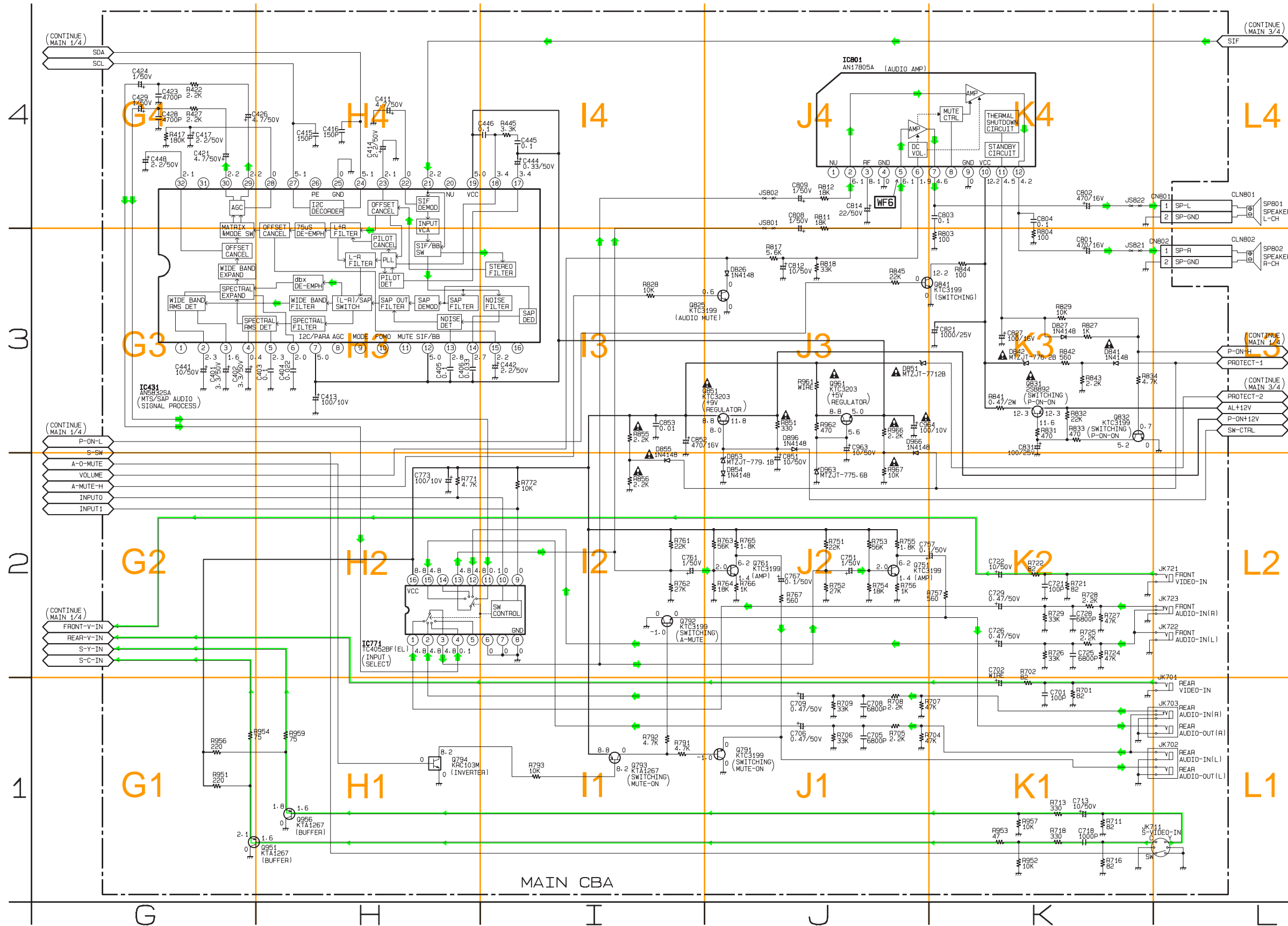

MAIN 2/4

Ref No.	Position
ICS	
IC431	G-3
IC771	H-2
IC801	J-4
TRANSISTORS	
Q751	J-2
Q761	J-2
Q791	J-1
Q792	I-2
Q793	I-1
Q794	H-1
Q825	J-3
Q831	K-3
Q832	K-3
Q841	K-3
Q851	J-3
Q951	H-1
Q961	J-3
CONNECTORS	
CN801	L-4
CN802	L-3





# Main 4/4 & CRT Schematic Diagram

MAIN 4/4

Ref No.	Position	Ref No.	Position	Ref No.	Position
IC		TRANSISTORS		TEST POINTS	
IC551	S-3	Q571	U-2	TP591	U-2
TRANSISTORS		Q572	T-2	TP592	U-2
Q531	S-2	CONNECTORS		TP601	U-2
Q533	S-2	CN571	T-3	VARIABLE RESISTORS	
Q547	U-2	WH301A	V-2	VR561	U-3
Q551	T-3	WH501A	V-3	VR562	U-3
Q552	T-3	TEST POINTS			
Q561	U-3	TP302	V-2		

CRT

Ref No.	Position
TRANSISTORS	
Q1511	W-1
Q1512	W-2
Q1521	W-1
Q1522	W-2
Q1531	W-1
Q1532	W-2
CONNECTORS	
CN1501	X-2
WH301B	V-2
WH501B	V-3
TEST POINTS	
TP500	W-1
TP501	W-2

VIDEO SIGNAL

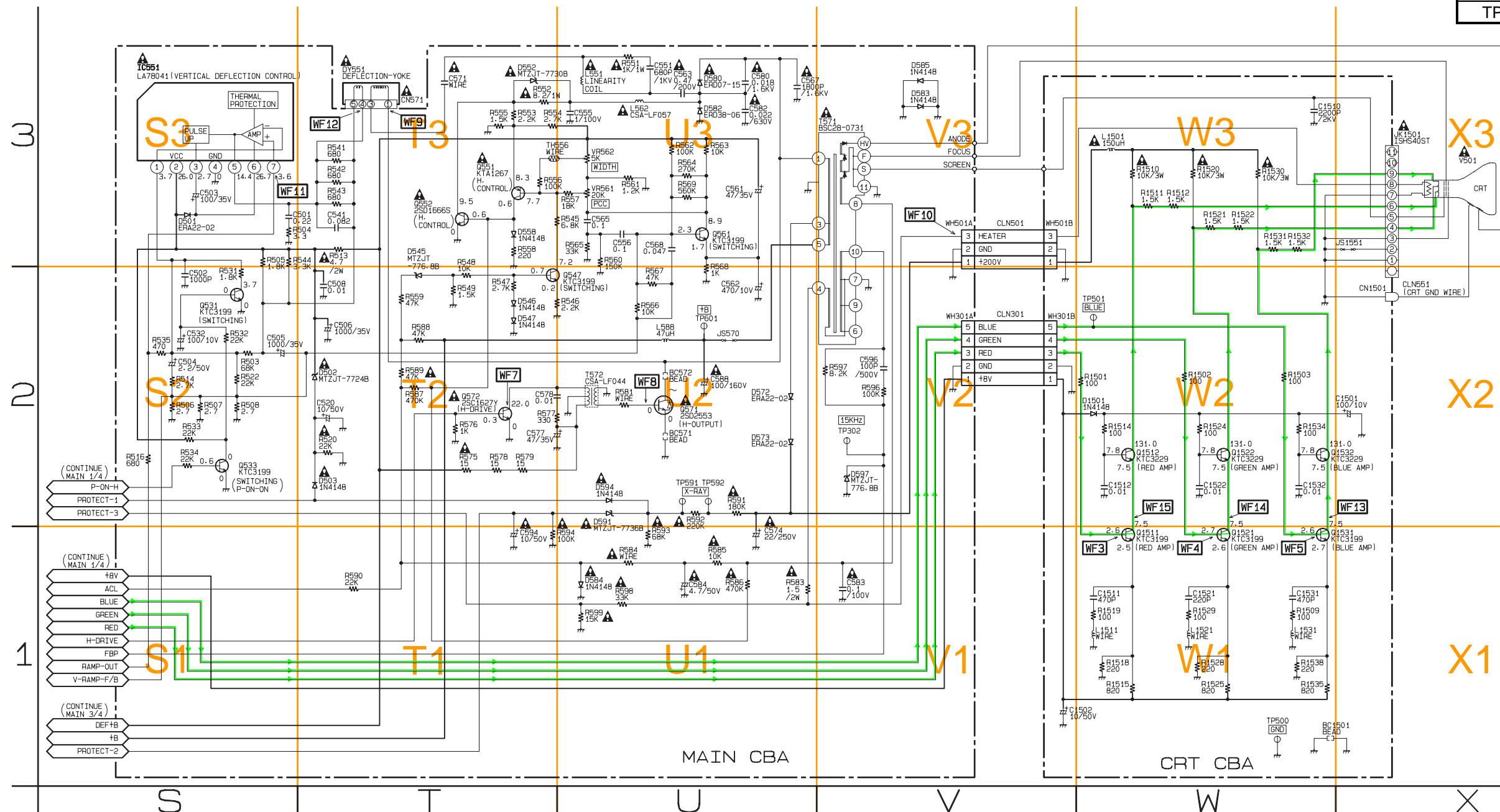

# Main CBA Top View

## CAUTION !

Fixed voltage ( or Auto voltage selectable ) power supply circuit is used in this unit.  
 If Main Fuse ( F601 ) is blown, check to see that all components in the power supply circuit are not defective before you connect the AC plug to the AC power supply.  
 Otherwise it may cause some components in the power supply circuit to fail.

## NOTE :

The voltage for parts in hot circuit is measured using hot GND as a common terminal.

**BECAUSE A HOT CHASSIS GROUND IS PRESENT IN THE POWER SUPPLY CIRCUIT, AN ISOLATION TRANSFORMER MUST BE USED. ALSO, IN ORDER TO HAVE THE ABILITY TO INCREASE THE INPUT SLOWLY, WHEN TROUBLESHOOTING THIS TYPE POWER SUPPLY CIRCUIT, A VARIABLE ISOLATION TRANSFORMER IS REQUIRED.**



**CAUTION:** FOR CONTINUED PROTECTION AGAINST RISK OF FIRE, REPLACE ONLY WITH SAME TYPE 4A, 125V FUSE.  
**ATTENTION:** UTILISER UN FUSIBLE DE RECHANGE DE MÊME TYPE DE 4A, 125V.

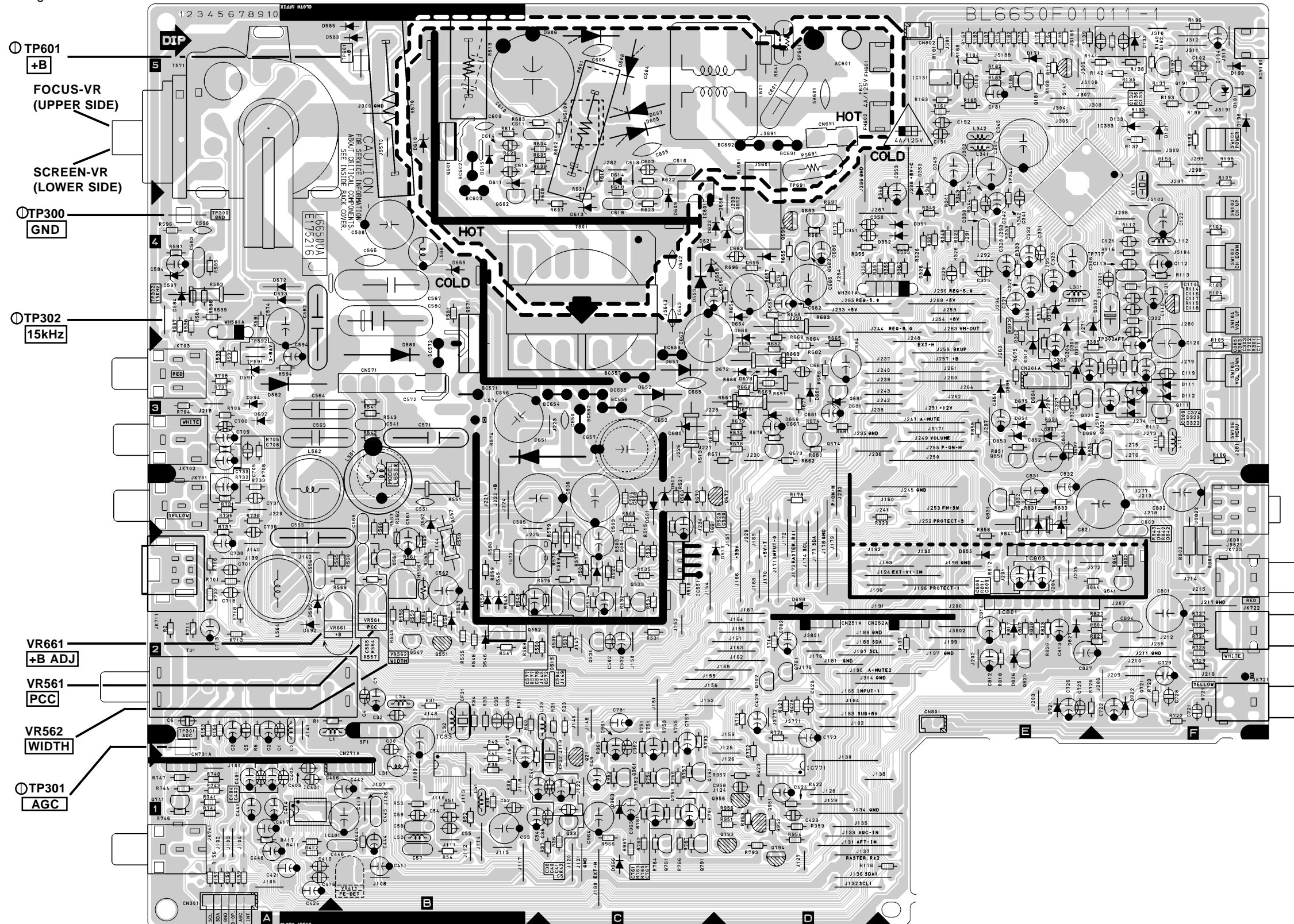

MAIN CBA

Ref No.	Position	Ref No.	Position
IC33		TRANSISTORS	
IC33	B-2	Q751	C-1
IC151	E-5	Q761	C-1
IC333	F-5	Q791	C-1
IC431	A-1	Q792	C-1
IC551	C-2	Q793	D-1
IC601	C-4	Q794	D-1
IC771	D-1	Q825	E-2
IC801	E-2	Q831	E-3
TRANSISTORS		Q832	F-3
Q21	C-1	Q841	F-2
Q33	C-1	Q851	E-3
Q111	F-3	Q951	D-1
Q131	F-4	Q956	D-1
Q141	E-5	Q961	C-1
Q191	F-5	CONNECTORS	
Q321	E-3	CN301	A-1
Q531	C-2	CN571	B-3
Q533	C-2	CN691	D-5
Q547	B-2	CN801	E-2
Q551	B-2	CN802	E-5
Q552	B-2	WH301A	D-4
Q561	B-2	WH501A	A-4
Q571	B-4	TEST POINTS	
Q572	C-2	TP300	A-4
Q601	B-1	TP301	A-2
Q602	B-4	TP302	A-4
Q652	D-4	TP591	A-3
Q672	D-3	TP592	A-3
Q673	D-3	TP601	B-5
Q674	D-3	VARIABLE RESISTOR	
Q681	D-3	VR561	B-2
Q682	D-4	VR562	B-2
Q683	D-4	VR661	B-2
Q696	D-4		

# Main CBA Bottom View

## CAUTION !

Fixed voltage ( or Auto voltage selectable ) power supply circuit is used in this unit.  
If Main Fuse (F601) is blown, check to see that all components in the power supply circuit are not defective before you connect the AC plug to the AC power supply.  
Otherwise it may cause some components in the power supply circuit to fail.



**CAUTION:** FOR CONTINUED PROTECTION AGAINST RISK OF FIRE, REPLACE ONLY WITH SAME TYPE 4A, 125V FUSE.  
**ATTENTION:** UTILISER UN FUSIBLE DE RECHANGE DE MÊME TYPE DE 4A, 125V.

## NOTE :

The voltage for parts in hot circuit is measured using hot GND as a common terminal.

**BECAUSE A HOT CHASSIS GROUND IS PRESENT IN THE POWER SUPPLY CIRCUIT, AN ISOLATION TRANSFORMER MUST BE USED. ALSO, IN ORDER TO HAVE THE ABILITY TO INCREASE THE INPUT SLOWLY, WHEN TROUBLESHOOTING THIS TYPE POWER SUPPLY CIRCUIT, A VARIABLE ISOLATION TRANSFORMER IS REQUIRED.**

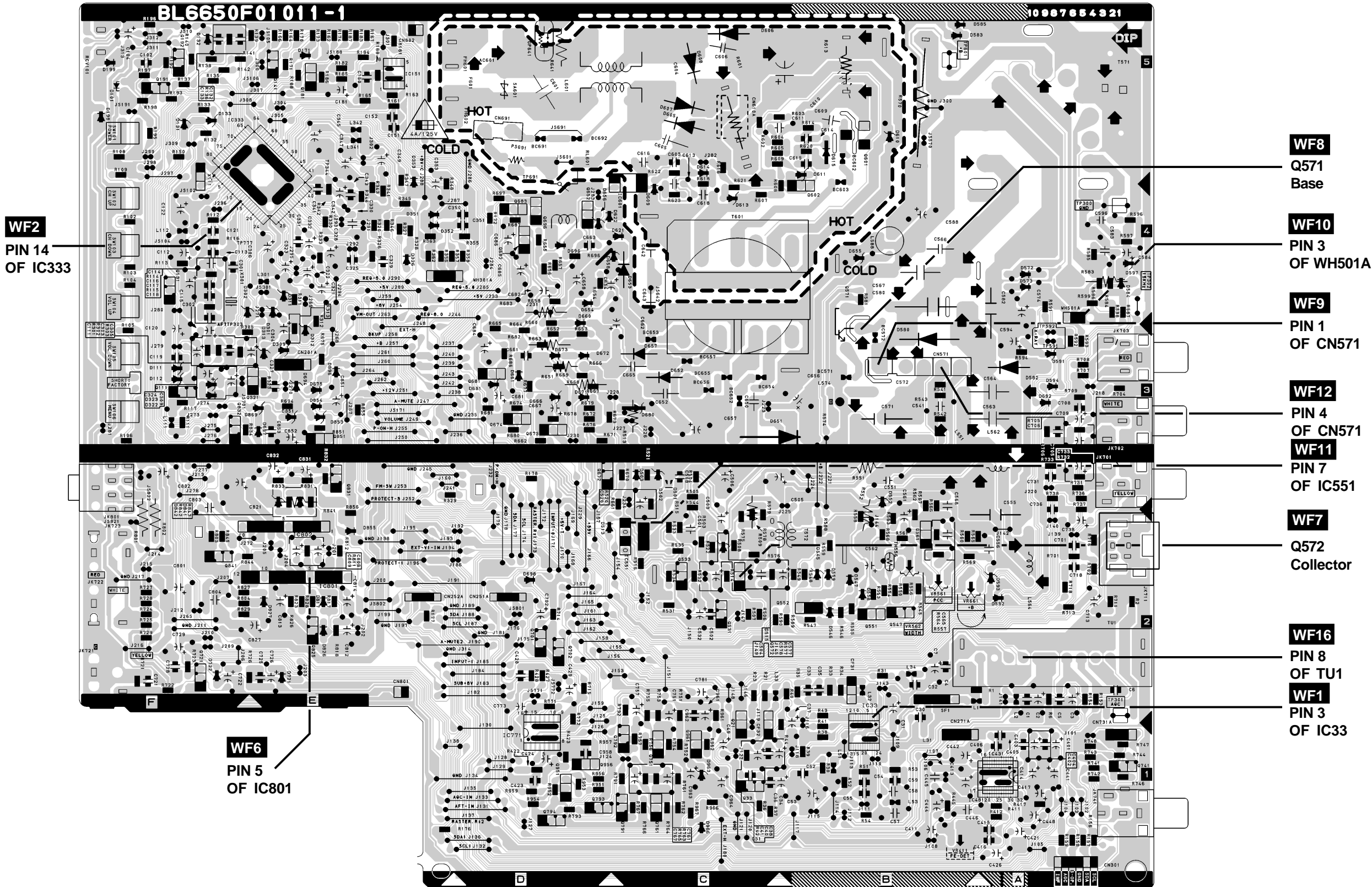

**WF2**  
PIN 14  
OF IC333

**WF6**  
PIN 5  
OF IC801

**WF8**  
Q571  
Base

**WF10**  
PIN 3  
OF WH501A

**WF9**  
PIN 1  
OF CN571

**WF12**  
PIN 4  
OF CN571

**WF11**  
PIN 7  
OF IC551

**WF7**  
Q572  
Collector

**WF16**  
PIN 8  
OF TU1

**WF1**  
PIN 3  
OF IC33

# CRT CBA Top View

# CRT CBA Bottom View

CRT CBA

Ref No.	Position
TRANSISTORS	
Q1511	C-1
Q1512	C-1
Q1521	C-1
Q1522	C-1
Q1531	B-1
Q1532	B-1
CONNECTORS	
CN1501	A-2
WH301B	B-2
WH501B	A-2
TEST POINTS	
TP500	B-2
TP501	B-2

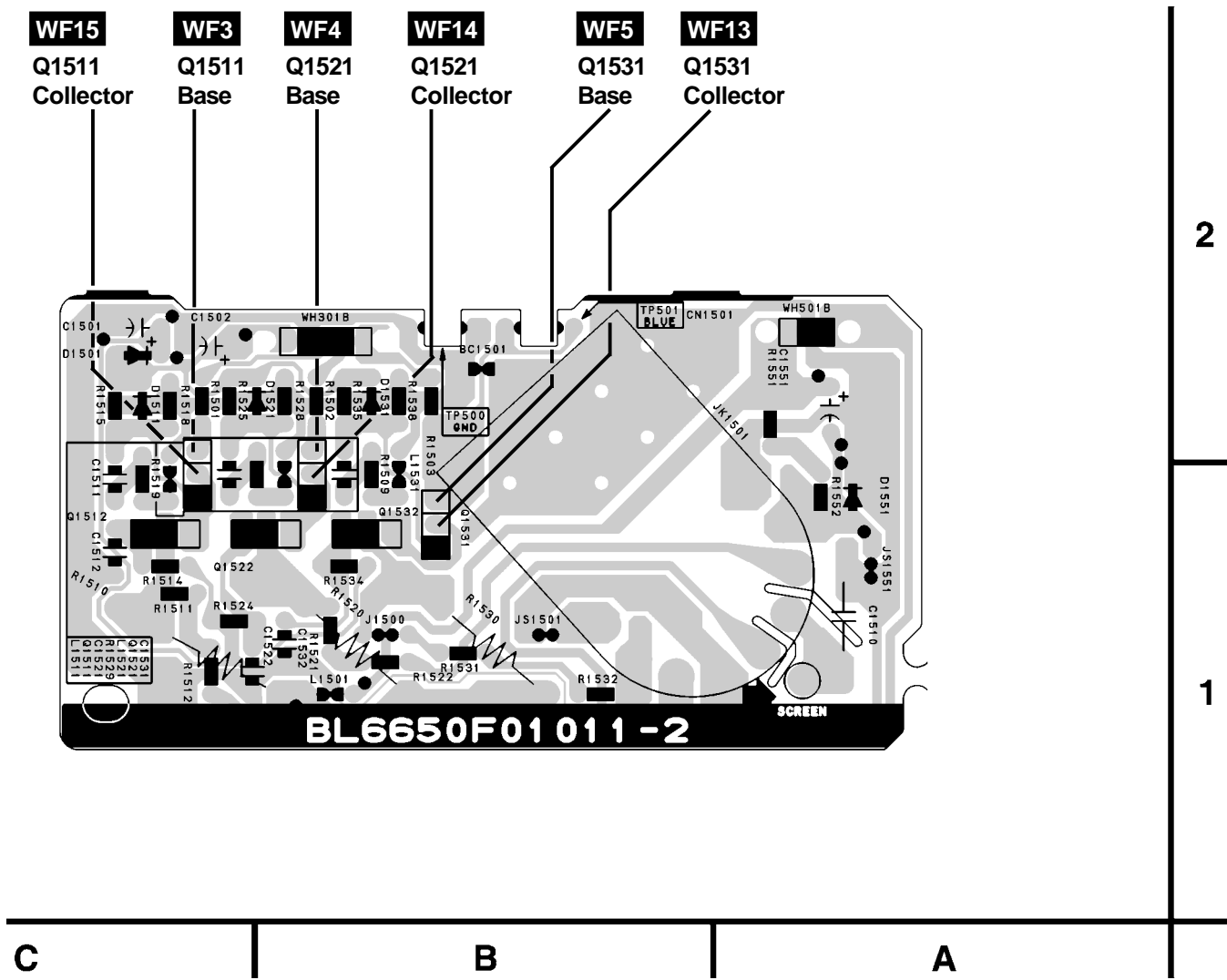
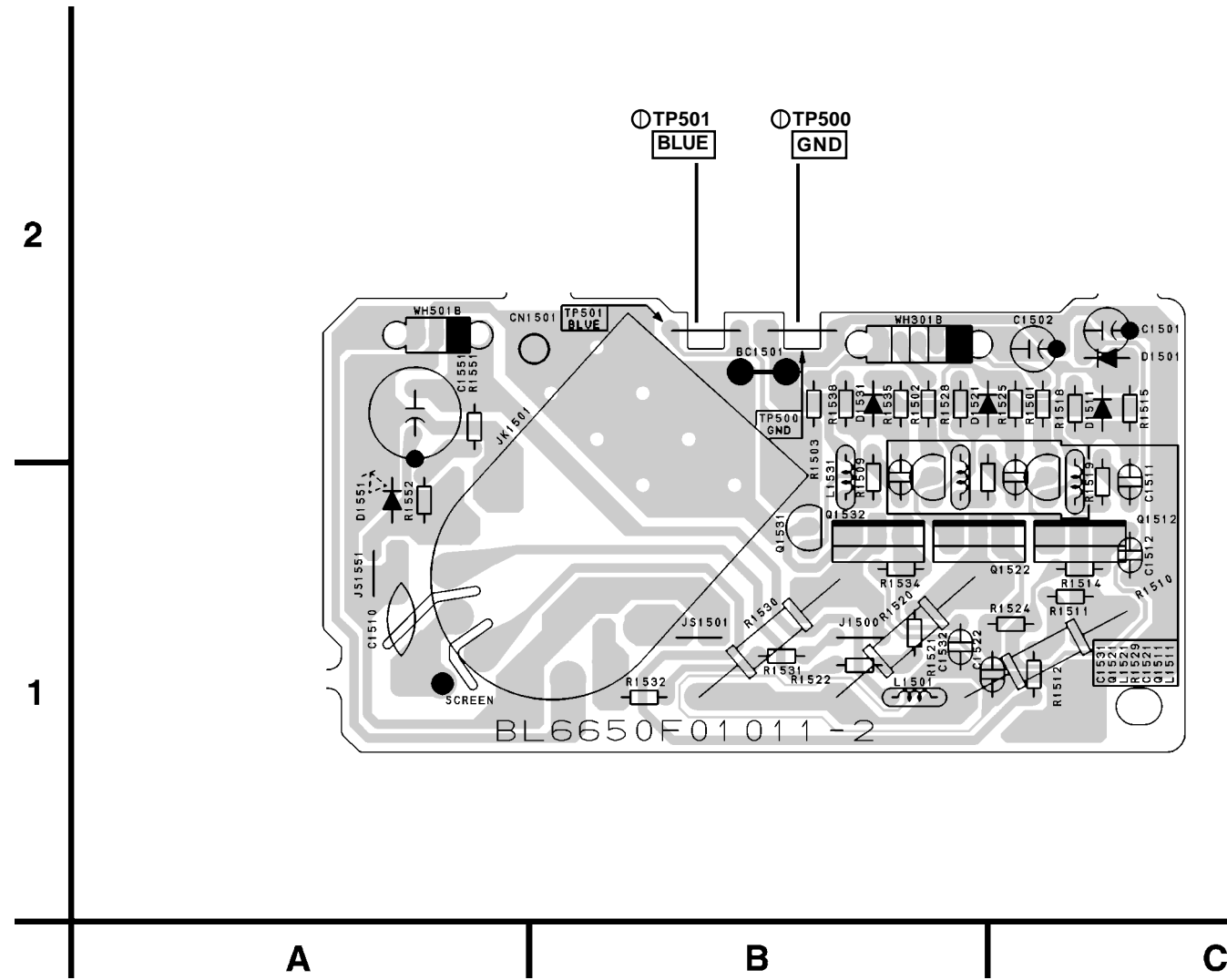

# WAVEFORMS

WF1 ~ WF16 = Waveforms to be observed at Waveform check points. (Shown in Schematic Diagram.)

**Input:** NTSC Color Bar Signal (with 1kHz Audio Signal)  
**INITIAL POSITION:** Unplug unit from AC outlet for at least 5 minutes. reconnect to AC outlet and then turn power on.  
 (Brightness---Center Color---Center Tint --- Center Contrast---Approx 70%)

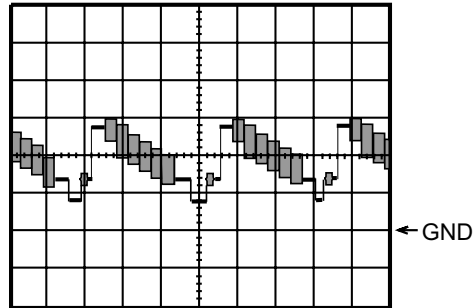

**WF1** 1DIV: 0.5V 20μsec  
IC 33 Pin 3

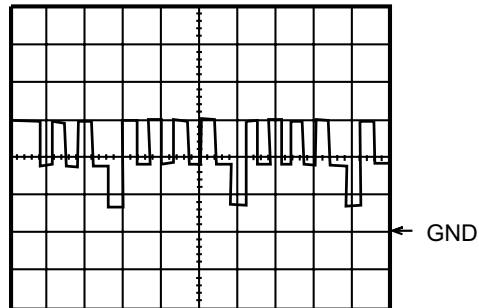

**WF5** 1DIV: 2V 20μsec  
Q 1531 Base

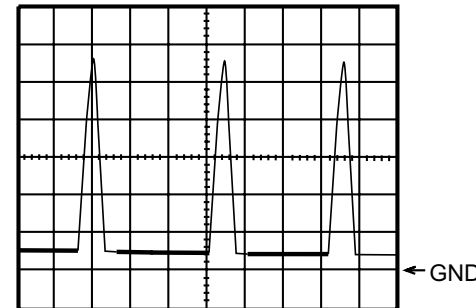

**WF9** 1DIV: 200V 20μsec  
CN 571 Pin 1

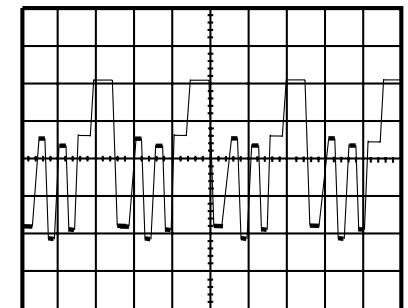

**WF13** 1DIV: 20V 20μsec  
Q 1531 Collector

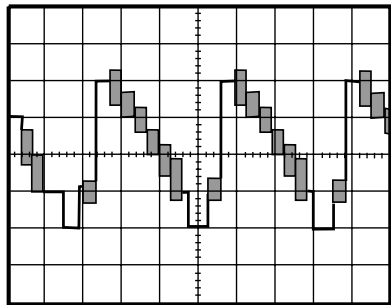

**WF2** 1DIV: 0.5V 20μsec  
IC 333 Pin 14

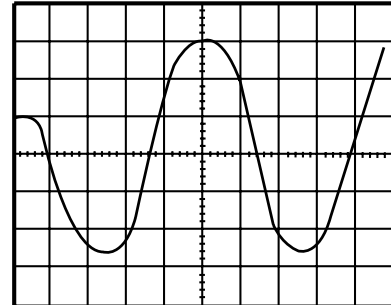

**WF6** 1DIV: 0.2V 20msec  
IC 801 Pin 5

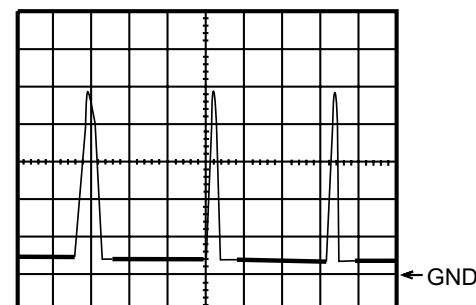

**WF10** 1DIV: 5V 20μsec  
WH501A Pin 3

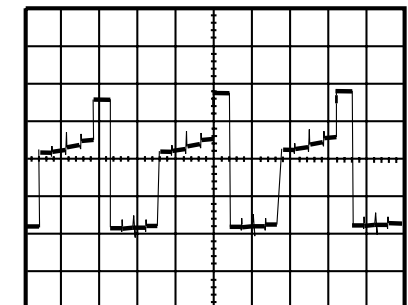

**WF14** 1DIV: 20V 20μsec  
Q 1521 Collector

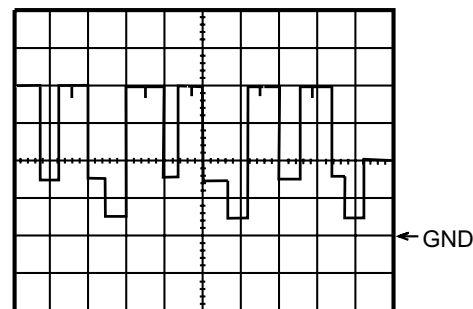

**WF3** 1DIV: 2V 20μsec  
Q 1511 Base

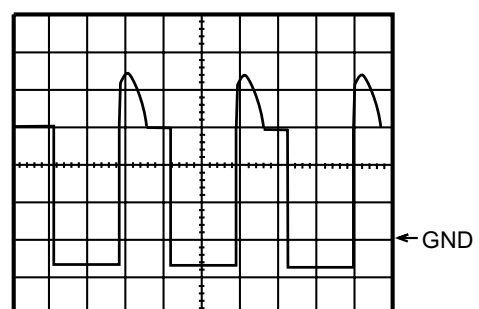

**WF7** 1DIV: 10V 20μsec  
Q 572 Collector

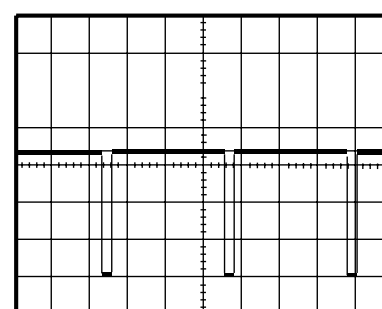

**WF11** 1DIV: 2V 5msec  
IC 551 Pin 7

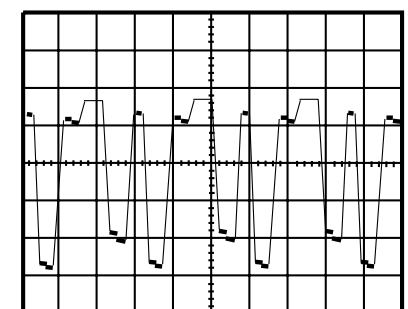

**WF15** 1DIV: 20V 20μsec  
Q 1511 Collector

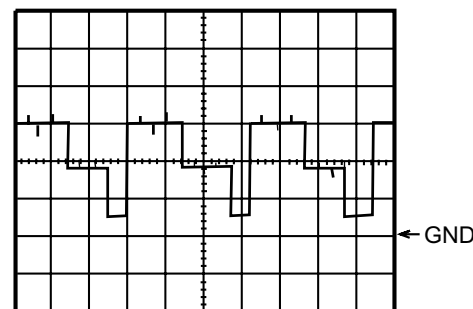

**WF4** 1DIV: 2V 20μsec  
Q 1521 Base

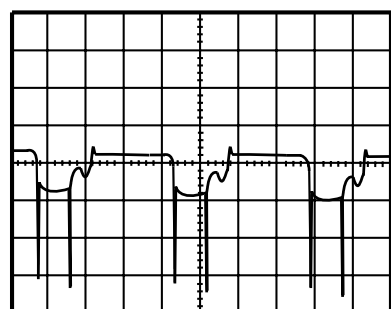

**WF8** 1DIV: 5V 20μsec  
Q 571 Base

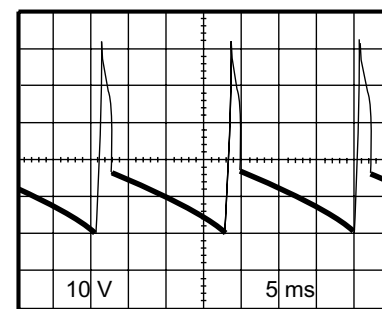

**WF12** 1DIV: 10V 5msec  
CN 571 Pin 4

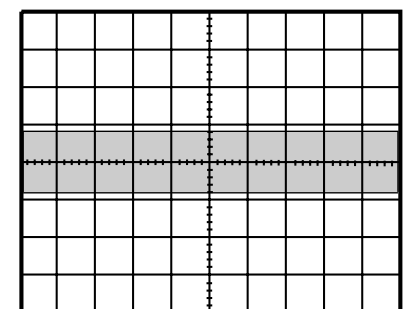

**WF16** 1DIV: 0.2V 20μsec  
TU 1 Pin 8

# WIRING DIAGRAM

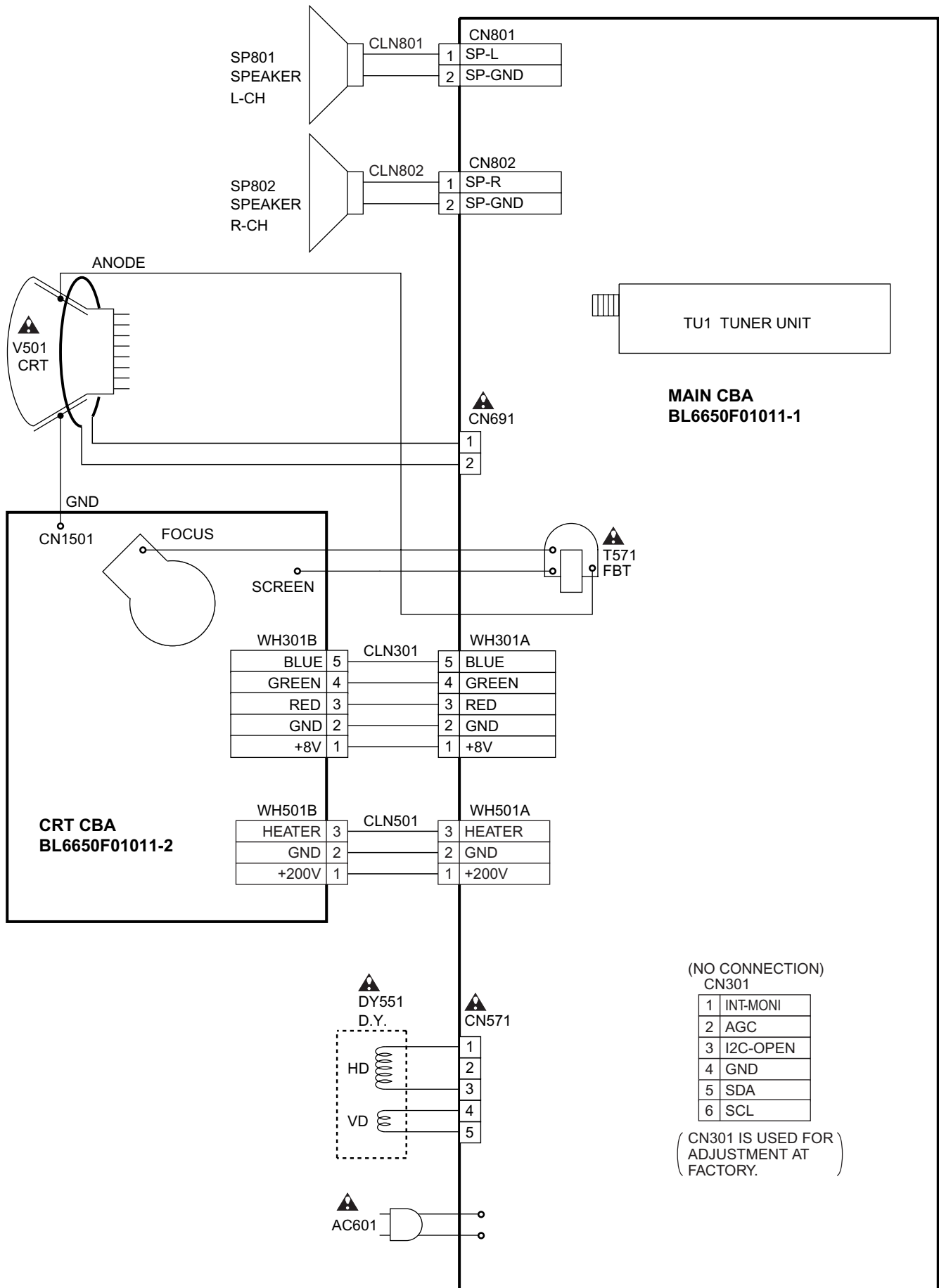

# IC PIN FUNCTIONS

## IC333 (TV Micro Computer)

Pin No.	Signal Name	Function
1	GND	GND
2	N.U.	Not Used
3	N.U.	Not Used
4	N.U.	Not Used
5	GND	GND
6	VCC	AL+5V
7	N.U.	Not Used
8	FILT	FILT
9	HLF	Filter for CCD
10	VHOLD	VHOLD
11	CVIN	Input for Video Signal
12	RESET	RESET
13	MCU RESET OUT	RESET Signal Output
14	Y-SW OUT	Composite Signal Output
15	GND	GND
16	3.58 X'TAL	3.58MHz Crystal
17	C-APC	CHROMINANCE APC
18	MCU 5.7REG OUT	Micro controller Control Voltage Output
19	N.U.	Not Used
20	CVBS IN 3	Composite Signal Input 3
21	N.U.	Not Used
22	VCC	VCC
23	N.U.	(GND)
24	CVBS IN2	Composite Signal Input 2
25	N.U.	Not Used
26	CVBS IN1	Composite Signal Input 1
27	N.U.	Not Used
28	5.7V REG OUT	5.7V Output
29	C(Y/C) IN	Chrominance Signal Input
30	Y(Y/C) IN	Luminance Signal Input
31	V REG VCC	DC 8.7V Input
32	FSC OUT	Clock Output 3.58MHz
33	MONITOR OUT	Monitor Out
34	N.U.	Not Used

Pin No.	Signal Name	Function
35	N.U.	Not Used
36	N.U.	Not Used
37	V RAMP F/B	V Ramp Feed Back
38	V RAMP OUT	Vertical Output
39	V RAMP CAP	V Ramp OSC Capacitor
40	8.7 VREG OUT	DC 8.7V Output
41	N.U.	Not Used
42	H VCO F/B	H Vco Feed Back
43	AFC FILT	Horizontal AFC Filter
44	GND	GND
45	FBP IN	Flyback Pulse Input
46	H-OUT	H Pulse Output
47	VCC	Vcc
48	VCC	Vcc
49	VCC	Vcc
50	R OUT	Red Output
51	G OUT	Green Output
52	B OUT	Blue Output
53	ACL	IB-Input
54	N.U.	Not Used
55	A-O-MUTE	Mute Signal of Audio Output
56	SDA	I2C-BUS Controller Interface (Data)
57	N.U.	Not Used
58	SCL	I2C-BUS Controller Interface (Clock)
59	N.U.	(GND)
60	N.U.	Not Used
61	S-SW	Detecting S-VIDEO Jack Connection
62	VOLUME	Volume
63	INPUTO	Input Select 0
64	A-MUTE-H	Audio Mute
65	N.U.	Not Used
66	KEY-IN 1	Key Input 1 (Main)
67	PROTECT-2	Power Supply Protection
68	PROTECT-1	Power Supply Protection
69	KEY-IN 2	Key Input 2 (Main)

<b>Pin No.</b>	<b>Signal Name</b>	<b>Function</b>
70	RCV-IN	Input For Remote Control
71	N.U.	Not Used
72	I2C OPEN	White Balance Adjustment Judgement
73	AFT	AFT Voltage Input
74	DG-ON-H	Degaussing Coil Control
75	AGC	AGC Voltage Input
76	PROTECT 3	Power Supply Protection
77	N.U.	Not Used
78	FM-SW	Switching IF IC VCO
79	P-ON-H	Output for P-ON-H
80	INPUT 1	Input Select 1



# EXPLODED VIEWS

## Cabinet

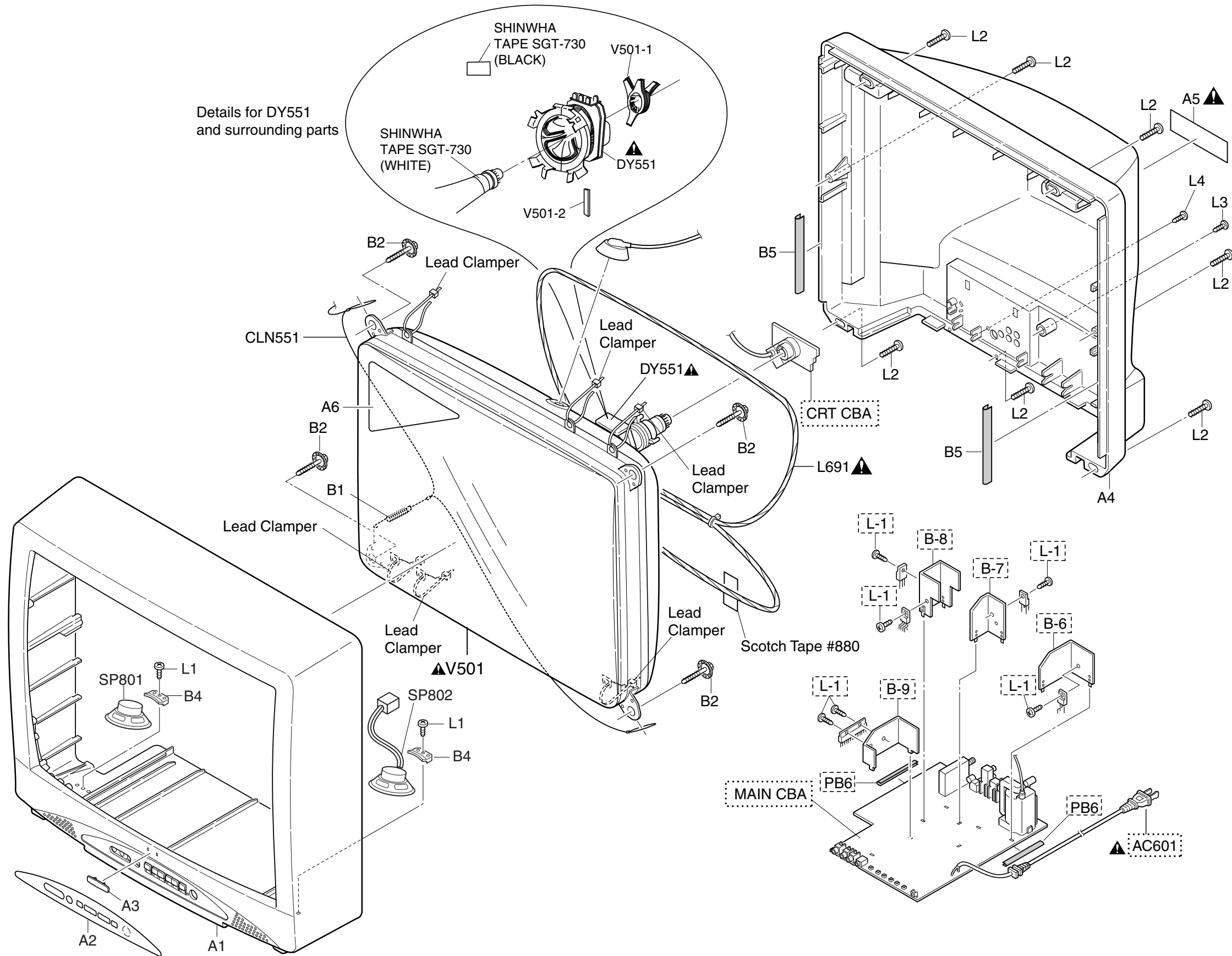

Details for DY551 and surrounding parts

# Packing

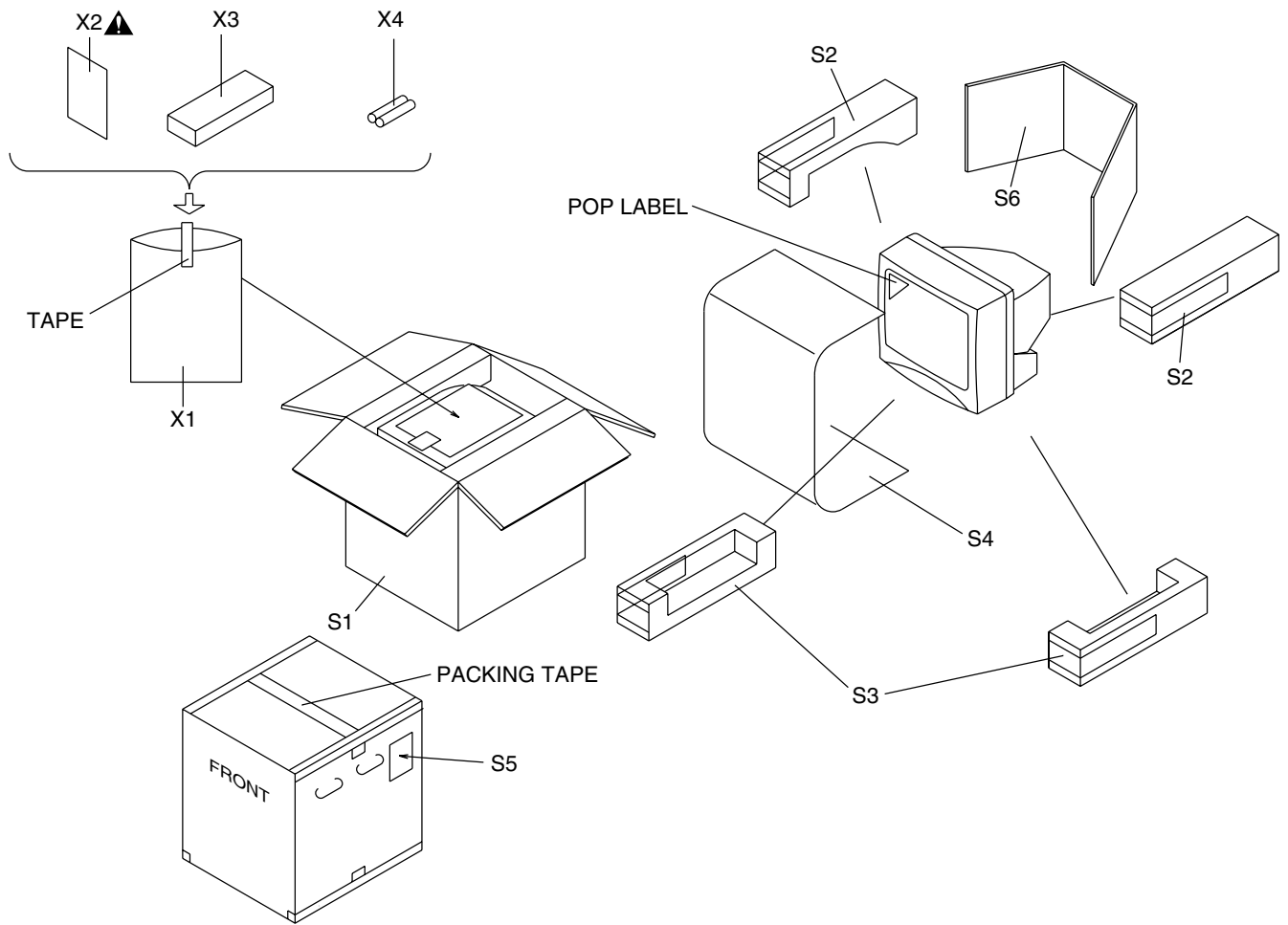

# MECHANICAL PARTS LIST

**PRODUCT SAFETY NOTE:** Products marked with a **▲** have special characteristics important to safety. Before replacing any of these components, read carefully the product safety notice in this service manual. Don't degrade the safety of the product through improper servicing.

**NOTE:**

Parts that are not assigned part numbers (-----) are not available.

Ref. No.	Description	Part No.
A1	FRONT CABINET L6250UA	0EM000625
A2	CONTROL PLATE L6250UA	0EM201570
A3	BRAND PLATE T5307UH:SYLVANIA	0EM407053
A4	REAR CABINET L6250UA	0EM000681
A5▲	RATING LABEL L6650UA	-----
A6	POP LABEL L6650UA	-----
B1	TENSION SPRING B0080B0:EM40808	26WH006
B2	M7 CRT SCREW(D22) T7205UF	0EM406573
B4	SPEAKER HOLDER L1200UA	0EM405691
B5	CLOTH 190X15XT0.5	TS7623
CLN551	CRT GND WIRE CRT GND WIRE	WX1L6250-005
L1	SCREW, P-TIGHT 3X12 BIND HEAD+	GBMP3120
L2	SCREW, P-TIGHT 4X18 BIND HEAD +	GBMP4180
L3	SCREW TAPPING M4X14	DBU14140
L4	SCREW, P-TIGHT 3X10 BIND HEAD+	GBKP3100
L691▲	DEGAUSSING COIL F-L1232V	LLBH00ZTM047
SP801	SPEAKER S08F16-J	DSD0808XQ009
SP802	SPEAKER S08F26-J	DSD0808XQ008
<b>Note:</b> 1. V501 (CRT) HAS COUPLE OF SUBSTITUTIONAL PARTS AND EACH PARTS ALSO HAS MATCHING COMBINATION WITH DY551. PLEASE SEE TABLE 1 FOR DETAILS OF MATCHING COMBINATION. 2. DY551 (DEFLECTION YOKE) HAS MATCHING COMBINATION WITH V501. PLEASE SEE TABLE 1 FOR DETAILS OF MATCHING COMBINATION.		
<b>CRT TYPE A</b>		
DY551▲	DEFLECTION YOKE 6150Z-1050M	LLBY00ZGS006
V501▲	CRT A80QCF340X	TCRT190GS041
V501-1	PCM 325LT-022	XM04000BV014
V501-2	WEDGE FT-00110W or	XV10000T4001
	WEDGE DB25SR	XV10000D9001
<b>CRT TYPE B</b>		
V501▲	CRT A80QCF340X03	TCRT190GS042
<b>CRT TYPE C</b>		
V501▲	CRT A80LJF30X11(CT)	TCRT190SEG01
<b>PACKING</b>		
S1	CARTON L6650UA	0EM407898
S2	STYROFOAM TOP ASSEMBLY L6250UA	0EM407000
S3	STYROFOAM BOTTOM ASSEMBLY L6250UA	0EM407001
S4	SET SHEET PCEC:003502019816	0EM403887
S5	SERIAL NO. LABEL L6650UA	-----
S6	HOLD PAD L6250UA	0EM407005
<b>ACCESSORIES</b>		
X1	POLYETHYLENE BAG F8626B5	Z325350
X2▲	OWNER'S MANUAL L6650UA	0EMN02090
X3	REMOTE CONTROL 130/ERC001/N0147UD	N0147UD
X4	DRY BATTERY R6P UM3 or	XB0M451GH001

Ref. No.	Description	Part No.
	DRY BATTERY R6P/2S or	XB0M451T0001
	DRY BATTERY(SUNRISE) R6SSE/2S or	XB0M451MS002
	DRY BATTERY R6P(AR)2PX or	XB0M451HU002
	DRY BATTERY R6P(AR)2P X ICI	XB0M451HU003

**Table 1 (V501 and DY551 Combination)**

**Note 1:** Purity and Convergence Adjustments must be performed following CRT replacement. Refer to Electrical Adjustment Instructions.

**Note 2:** Please confirm CRT Type No. on the CRT Warning Label which is located on the CRT. Then See the Table 1 for V501 and DY551 combination chart. Please refer this CRT, Deflection Yoke combination chart for parts order.

V501: CRT Type No.	V501: CRT Part No.	DY551: Deflection Yoke Part No.
CRT A80QCF340X	TCRT190GS041	LLBY00ZGS006
CRT A80QCF340X03	TCRT190GS042	-----
CRT A80LJF30X11(CT)	TCRT190SEG01	-----

**CRT Warning Label Location**

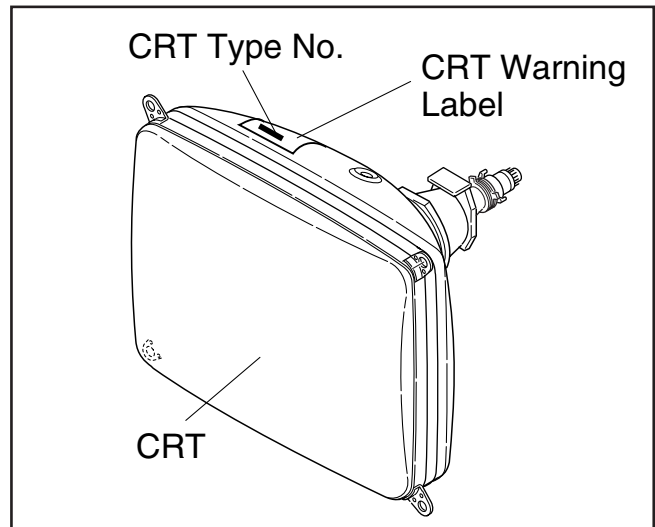

# ELECTRICAL PARTS LIST

**PRODUCT SAFETY NOTE:** Products marked with a  have special characteristics important to safety. Before replacing any of these components, read carefully the product safety notice in this service manual. Don't degrade the safety of the product through improper servicing.

## NOTES:

- Parts that are not assigned part numbers (-----) are not available.
- Tolerance of Capacitors and Resistors are noted with the following symbols.

C.....±0.25%    D.....±0.5%    F.....±1%  
 G.....±2%    J.....±5%    K.....±10%  
 M.....±20%    N.....±30%    Z.....+80/-20%

## MMA CBA

Ref. No.	Description	Part No.
	MMA-406 CBA Consists of the following	0ESA05248
	MAIN CBA	-----
	CRT CBA	-----

## MAIN CBA

Ref. No.	Description	Part No.
	MAIN CBA Consists of the following	-----
<b>CAPACITORS</b>		
C1	CERAMIC CAP.(AX) F Z 0.01µF/25V	CDA1EZT0F103
C2	ELECTROLYTIC CAP. 100µF/10V M or ELECTROLYTIC CAP. 100µF/10V M	CE1AMASTL101 CE1AMASDL101
C3	ELECTROLYTIC CAP. 4.7µF/50V M or ELECTROLYTIC CAP. 4.7µF/50V M	CE1JMASTL4R7 CE1JMASDL4R7
C4	CERAMIC CAP.(AX) F Z 0.01µF/50V	CA1J103TU014
C7	ELECTROLYTIC CAP. 1µF/50V M or ELECTROLYTIC CAP. 1µF/50V M or ELECTROLYTIC CAP. 1µF/50V M or ELECTROLYTIC CAP. 1µF/50V M	CE1JMASTL1R0 CE1JMASTL010 CE1JMASDL1R0 CE1JMASDL010
C30	PCB JUMPER D0.6-P5.0	JW5.0T
C31	ELECTROLYTIC CAP. 100µF/10V M or ELECTROLYTIC CAP. 100µF/10V M	CE1AMASTL101 CE1AMASDL101
C32	CERAMIC CAP.(AX) F Z 0.01µF/25V	CDA1EZT0F103
C34	ELECTROLYTIC CAP. 0.47µF/50V M or ELECTROLYTIC CAP. 0.47µF/50V M	CE1JMASTL4R7 CE1JMASDL4R7
C35	CERAMIC CAP.(AX) CH J 56pF/50V	CA1J560TU008
C36	CERAMIC CAP.(AX) B K 1000pF/50V	CCA1JKTOB102
C37	ELECTROLYTIC CAP. 1µF/50V M or ELECTROLYTIC CAP. 1µF/50V M or ELECTROLYTIC CAP. 1µF/50V M or ELECTROLYTIC CAP. 1µF/50V M	CE1JMASTL1R0 CE1JMASTL010 CE1JMASDL1R0 CE1JMASDL010
C38	ELECTROLYTIC CAP. 10µF/50V M or ELECTROLYTIC CAP. 10µF/50V M	CE1JMASTL100 CE1JMASDL100
C41	ELECTROLYTIC CAP. 0.47µF/50V M or	CE1JMASTL4R7

Ref. No.	Description	Part No.
	ELECTROLYTIC CAP. 0.47µF/50V M	CE1JMASDLR47
C49	ELECTROLYTIC CAP. 4.7µF/50V M or ELECTROLYTIC CAP. 4.7µF/50V M	CE1JMASTL4R7 CE1JMASDL4R7
C51	CERAMIC CAP.(AX) B K 1000pF/50V	CCA1JKTOB102
C52	CERAMIC CAP.(AX) F Z 0.01µF/25V	CDA1EZT0F103
C53	ELECTROLYTIC CAP. 100µF/10V M or ELECTROLYTIC CAP. 100µF/10V M	CE1AMASTL101 CE1AMASDL101
C54	CERAMIC CAP.(AX) B K 1000pF/50V	CCA1JKTOB102
C55	CERAMIC CAP.(AX) F Z 0.01µF/25V	CDA1EZT0F103
C57	FILM CAP.(P) 0.047µF/50V J or FILM CAP.(P) 0.047µF/50V J or FILM CAP.(P) 0.047µF/50V J TV or MYLAR CAP. 0.047µF/50V K	CMA1JJS00473 CA1J473MS029 CMB1JJS00473 2250473S
C58	FILM CAP.(P) 0.033µF/50V J or FILM CAP.(P) 0.033µF/50V J or FILM CAP.(P) 0.033µF/50V J TV	CMA1JJS00333 CA1J333MS029 CMB1JJS00333
C104	ELECTROLYTIC CAP. 10µF/50V M or ELECTROLYTIC CAP. 10µF/50V M	CE1JMASTL100 CE1JMASDL100
C111	ELECTROLYTIC CAP. 47µF/16V M or ELECTROLYTIC CAP. 47µF/16V M	CE1CMASTL470 CE1CMASDL470
C112	ELECTROLYTIC CAP. 4.7µF/50V M or ELECTROLYTIC CAP. 4.7µF/50V M	CE1JMASTL4R7 CE1JMASDL4R7
C113	CERAMIC CAP. F Z 0.1µF/25V	CDA1EZT0F104
C114	FILM CAP.(P) 0.001µF/50V J or FILM CAP.(P) 0.001µF/50V J or FILM CAP.(P) 0.001µF/50V J TV or MYLAR CAP. 0.001µF/50V K	CMA1JJS00102 CA1J102MS029 CMB1JJS00102 2250102S
C115	ELECTROLYTIC CAP. 0.1µF/50V M or ELECTROLYTIC CAP. 0.1µF/50V M	CE1JMASTLR10 CE1JMASDLR10
C116	CERAMIC CAP.(AX) B K 220pF/50V	CCA1JKTOB221
C117	CERAMIC CAP.(AX) Y K 0.01µF/16V	CDA1CKT0Y103
C119	CERAMIC CAP.(AX) F Z 0.01µF/25V	CDA1EZT0F103
C120	ELECTROLYTIC CAP. 100µF/10V M or ELECTROLYTIC CAP. 100µF/10V M	CE1AMASTL101 CE1AMASDL101
C122	ELECTROLYTIC CAP. 100µF/10V M or ELECTROLYTIC CAP. 100µF/10V M	CE1AMASTL101 CE1AMASDL101
C132	CERAMIC CAP. F Z 0.1µF/25V	CDA1EZT0F104
C133	CERAMIC CAP.(AX) F Z 0.01µF/25V	CDA1EZT0F103
C150	CERAMIC CAP. F Z 0.1µF/25V	CDA1EZT0F104
C151	CERAMIC CAP.(AX) B K 220pF/50V	CCA1JKTOB221
C152	CERAMIC CAP.(AX) B K 220pF/50V	CCA1JKTOB221
C301	CERAMIC CAP.(AX) CH J 120pF/50V	CA1J121TU008
C302	ELECTROLYTIC CAP. 1µF/50V M or ELECTROLYTIC CAP. 1µF/50V M or ELECTROLYTIC CAP. 1µF/50V M	CE1JMASTL1R0 CE1JMASTL010 CE1JMASDL1R0
C303	CERAMIC CAP.(AX) B K 0.015µF/50V	CA1J153TU011
C305	ELECTROLYTIC CAP. 0.1µF/50V M or ELECTROLYTIC CAP. 0.1µF/50V M	CE1JMASTLR10 CE1JMASDLR10
C306	ELECTROLYTIC CAP. 100µF/10V M or ELECTROLYTIC CAP. 100µF/10V M	CE1AMASTL101 CE1AMASDL101
C309	ELECTROLYTIC CAP. 0.1µF/50V M or ELECTROLYTIC CAP. 0.1µF/50V M	CE1JMASTLR10 CE1JMASDLR10
C322	ELECTROLYTIC CAP. 0.47µF/50V M or ELECTROLYTIC CAP. 0.47µF/50V M	CE1JMASTL4R7 CE1JMASDLR47
C324	ELECTROLYTIC CAP. 10µF/50V M or ELECTROLYTIC CAP. 10µF/50V M	CE1JMASTL100 CE1JMASDL100

Ref. No.	Description	Part No.
C325	CERAMIC CAP.(AX) SL J 12pF/50V	CCA1JUTSL120
C328	ELECTROLYTIC CAP. 10μF/50V M or	CE1JMASTL100
	ELECTROLYTIC CAP. 10μF/50V M	CE1JMASDL100
C329	CERAMIC CAP.(AX) F Z 0.01μF/25V	CDA1EZT0F103
C330	STACKED FILM CAP. 0.47μF/50V J or	CMA1JJS00474
	FILM CAP.(P) 0.47μF/50V J	CA1J474MS029
C331	CERAMIC CAP.(AX) B K 1000pF/50V	CCA1JKT0B102
C332	ELECTROLYTIC CAP. 10μF/50V M or	CE1JMASTL100
	ELECTROLYTIC CAP. 10μF/50V M	CE1JMASDL100
C341	CERAMIC CAP.(AX) B K 0.01μF/50V	CA1J103TU011
C342	ELECTROLYTIC CAP. 1μF/50V M or	CE1JMASTL1R0
	ELECTROLYTIC CAP. 1μF/50V M or	CE1JMASTL010
	ELECTROLYTIC CAP. 1μF/50V M or	CE1JMASDL1R0
	ELECTROLYTIC CAP. 1μF/50V M	CE1JMASDL010
C343	CERAMIC CAP.(AX) B K 0.01μF/50V	CA1J103TU011
C345	ELECTROLYTIC CAP. 2200μF/10V M or	CE1AMZNTL222
	ELECTROLYTIC CAP. 2200μF/10V M	CE1AMZNDL222
C347	ELECTROLYTIC CAP. 470μF/10V M or	CE1AMASTL471
	ELECTROLYTIC CAP. 470μF/10V M	CE1AMASDL471
C349	ELECTROLYTIC CAP. 470μF/10V M or	CE1AMASTL471
	ELECTROLYTIC CAP. 470μF/10V M	CE1AMASDL471
C353	ELECTROLYTIC CAP. 1μF/50V M or	CE1JMASTL1R0
	ELECTROLYTIC CAP. 1μF/50V M or	CE1JMASTL010
	ELECTROLYTIC CAP. 1μF/50V M or	CE1JMASDL1R0
	ELECTROLYTIC CAP. 1μF/50V M	CE1JMASDL010
C401	ELECTROLYTIC CAP. 3.3μF/50V M or	CE1JMASTL3R3
	ELECTROLYTIC CAP. 3.3μF/50V M	CE1JMASDL3R3
C402	ELECTROLYTIC CAP. 3.3μF/50V M or	CE1JMASTL3R3
	ELECTROLYTIC CAP. 3.3μF/50V M	CE1JMASDL3R3
C403	CERAMIC CAP.(AX) F Z 0.1μF/50V or	CA1J104TU014
	CERAMIC CAP.(AX) F Z 0.1μF/50V	CCA1JZT0F104
C404	CERAMIC CAP.(AX) B K 0.022μF/50V	CA1J223TU011
C405	CERAMIC CAP. F Z 0.1μF/25V	CDA1EZT0F104
C406	CERAMIC CAP.(AX) B K 0.033μF/50V	CA1J333TU011
C411	ELECTROLYTIC CAP. 4.7μF/50V M or	CE1JMASTL4R7
	ELECTROLYTIC CAP. 4.7μF/50V M	CE1JMASDL4R7
C413	ELECTROLYTIC CAP. 100μF/10V M or	CE1AMASTL101
	ELECTROLYTIC CAP. 100μF/10V M	CE1AMASDL101
C414	ELECTROLYTIC CAP. 2.2μF/50V M or	CE1JMASTL2R2
	ELECTROLYTIC CAP. 2.2μF/50V M	CE1JMASDL2R2
C415	CERAMIC CAP.(AX) B K 150pF/50V	CCA1JKT0B151
C416	CERAMIC CAP.(AX) B K 150pF/50V	CCA1JKT0B151
C417	ELECTROLYTIC CAP. 2.2μF/50V M or	CE1JMASTL2R2
	ELECTROLYTIC CAP. 2.2μF/50V M	CE1JMASDL2R2
C421	ELECTROLYTIC CAP. 4.7μF/50V M or	CE1JMASTL4R7
	ELECTROLYTIC CAP. 4.7μF/50V M	CE1JMASDL4R7
C423	CERAMIC CAP.(AX) X K 4700pF/16V	CDA1CKT0X472
C424	ELECTROLYTIC CAP. 1μF/50V M or	CE1JMASTL1R0
	ELECTROLYTIC CAP. 1μF/50V M or	CE1JMASTL010
	ELECTROLYTIC CAP. 1μF/50V M or	CE1JMASDL1R0
	ELECTROLYTIC CAP. 1μF/50V M	CE1JMASDL010
C426	ELECTROLYTIC CAP. 4.7μF/50V M or	CE1JMASTL4R7
	ELECTROLYTIC CAP. 4.7μF/50V M	CE1JMASDL4R7
C428	CERAMIC CAP.(AX) X K 4700pF/16V	CDA1CKT0X472
C429	ELECTROLYTIC CAP. 1μF/50V M or	CE1JMASTL1R0
	ELECTROLYTIC CAP. 1μF/50V M or	CE1JMASTL010
	ELECTROLYTIC CAP. 1μF/50V M or	CE1JMASDL1R0
	ELECTROLYTIC CAP. 1μF/50V M	CE1JMASDL010
C441	ELECTROLYTIC CAP. 10μF/50V M or	CE1JMASTL100
	ELECTROLYTIC CAP. 10μF/50V M	CE1JMASDL100
C442	ELECTROLYTIC CAP. 2.2μF/50V M or	CE1JMASTL2R2

Ref. No.	Description	Part No.
	ELECTROLYTIC CAP. 2.2μF/50V M	CE1JMASDL2R2
C444	ELECTROLYTIC CAP. 0.33μF/50V M or	CE1JMASTL3R3
	ELECTROLYTIC CAP. 0.33μF/50V M	CE1JMASDL3R3
C445	FILM CAP.(P) 0.1μF/50V J or	CMA1JJS00104
	FILM CAP.(P) 0.1μF/50V J or	CA1J104MS029
	FILM CAP.(P) 0.1μF/50V J TV or	CMB1JJS00104
	MYLAR CAP. 0.1μF/50V K	2250104S
C446	FILM CAP.(P) 0.1μF/50V J or	CMA1JJS00104
	FILM CAP.(P) 0.1μF/50V J or	CA1J104MS029
	FILM CAP.(P) 0.1μF/50V J TV or	CMB1JJS00104
	MYLAR CAP. 0.1μF/50V K	2250104S
C448	ELECTROLYTIC CAP. 2.2μF/50V M or	CE1JMASTL2R2
	ELECTROLYTIC CAP. 2.2μF/50V M	CE1JMASDL2R2
C501	FILM CAP. 0.22μF/50V J or	122Z313S
	TF CAP. 0.22μF/50V J	CT1J224MS045
C502	CERAMIC CAP.(AX) B K 1000pF/50V	CCA1JKT0B102
C503	ELECTROLYTIC CAP. 100μF/35V M or	CE1GMASTL101
	ELECTROLYTIC CAP. 100μF/35V M	CE1GMASDL101
C504	ELECTROLYTIC CAP. 2.2μF/50V M LL or	CE1JMASTL2R2
	ELECTROLYTIC CAP. 2.2μF/50V LL	CE1JMASLH2R2
C505	ELECTROLYTIC CAP. 1000μF/35V M or	CE1GMZNTL102
	ELECTROLYTIC CAP. 1000μF/35V M or	CE1GMZNDL102
	ELECTROLYTIC CAP. 1000μF/35V M	CE1GMZADL102
C506	ELECTROLYTIC CAP. 1000μF/35V M or	CE1GMZNTL102
	ELECTROLYTIC CAP. 1000μF/35V M or	CE1GMZNDL102
	ELECTROLYTIC CAP. 1000μF/35V M	CE1GMZADL102
C508	CERAMIC CAP.(AX) F Z 0.01μF/25V	CDA1EZT0F103
C520	ELECTROLYTIC CAP. 10μF/50V M or	CE1JMASTL100
	ELECTROLYTIC CAP. 10μF/50V M	CE1JMASDL100
C532	ELECTROLYTIC CAP. 100μF/10V M or	CE1AMASTL101
	ELECTROLYTIC CAP. 100μF/10V M	CE1AMASDL101
C541	FILM CAP.(P) 0.082μF/50V J or	CMA1JJS00823
	FILM CAP.(P) 0.082μF/50V J	CA1J823MS029
C551	CERAMIC CAP. B K 680pF/1KV or	CCD3AKD0B681
	CERAMIC CAP. B K 680pF/1KV or	CCD3AKP0B681
	CERAMIC CAP. B K 680pF/1KV	CA3A681MR028
C555	METALIZED PLYESTER CAP. 1μF/100V J	CT2A105MS065
C556	FILM CAP.(P) 0.1μF/50V J or	CMA1JJS00104
	FILM CAP.(P) 0.1μF/50V J or	CA1J104MS029
	FILM CAP.(P) 0.1μF/50V J TV or	CMB1JJS00104
	MYLAR CAP. 0.1μF/50V K	2250104S
C561	ELECTROLYTIC CAP. 47μF/35V M or	CE1GMASTL470
	ELECTROLYTIC CAP. 47μF/35V M	CE1GMASDL470
C562	ELECTROLYTIC CAP. 470μF/10V M or	CE1AMASTL471
	ELECTROLYTIC CAP. 470μF/10V M	CE1AMASDL471
C563▲	PP.CAP 0.47μF/200 J or	CA2D474VC012
▲	PP CAP 0.47μF/250V J	CT2E474MS041
C565	FILM CAP.(P) 0.1μF/50V J or	CMA1JJS00104
	FILM CAP.(P) 0.1μF/50V J or	CA1J104MS029
	FILM CAP.(P) 0.1μF/50V J TV or	CMB1JJS00104
	MYLAR CAP. 0.1μF/50V K	2250104S
C567▲	PP CAP 0.0018μF/1.6KV J or	CA3C182VC010
▲	PP CAP 0.0018μF/1.6KV J	CT3C182MS039
C568	FILM CAP.(P) 0.047μF/50V J or	CMA1JJS00473
	FILM CAP.(P) 0.047μF/50V J or	CA1J473MS029
	FILM CAP.(P) 0.047μF/50V J TV or	CMB1JJS00473
	MYLAR CAP. 0.047μF/50V K	2250473S
C571▲	PCB JUMPER D0.6-P10.0	JW10.0T
C574▲	ELECTROLYTIC CAP. 22μF/250V M or	CE2EMZPTL220
▲	ELECTROLYTIC CAP. 22μF/250V M	CE2EMZNDL220
C577	ELECTROLYTIC CAP. 47μF/35V M or	CE1GMASTL470

Ref. No.	Description	Part No.
	ELECTROLYTIC CAP. 47µF/35V M	CE1GMASDL470
C578	FILM CAP.(P) 0.01µF/50V J or	CMA1JJS00103
	FILM CAP.(P) 0.01µF/50V J or	CA1J103MS029
	FILM CAP.(P) 0.01µF/50V J TV or	CMB1JJS00103
	MYLAR CAP. 0.01µF/50V K	2250103S
C580▲	PP CAP. 0.018µF/1.6KV J or	CA3C183VC010
▲	PP CAP. 0.018µF/1.6KV J	CT3C183MS039
C582▲	P.P. CAPACITOR 0.022µF/630V J or	CBP2KJD00223
▲	P.P. CAPACITOR 0.022µF/630V J or	CT2K223KF011
▲	P.P. CAPACITOR 0.022µF/630V J	CBP2KKD00223
C583▲	FILM CAP.(P) 0.1µF/100V J or	CMA2AJS00104
▲	FILM CAP.(P) 0.1µF/100V J TV	CMB2AJS00104
C584▲	ELECTROLYTIC CAP. 4.7µF/50V M or	CE1JMASTL4R7
▲	ELECTROLYTIC CAP. 4.7µF/50V M	CE1JMASDL4R7
C588▲	ELECTROLYTIC CAP. 100µF/160V M W/F or	CE2CMZNTL101
▲	ELECTROLYTIC CAP. 100µF/160V M	CE2CMZPDL101
C594▲	ELECTROLYTIC CAP. 10µF/50V M or	CE1JMASTL100
▲	ELECTROLYTIC CAP. 10µF/50V M	CE1JMASDL100
C596	CERAMIC CAP. B K 100pF/500V	CCD2JKS0B101
C601▲	METALLIZED FILM CAP. 0.1µF/250V or	CT2E104MS037
▲	METALLIZED FILM CAP. 0.1µF/275V K or	CT2E104HJE06
▲	FILM CAP.(MP) 0.1µF/250V K or	CT2E104DC011
▲	METALLIZED FILM CAP. 0.1µF/275V K	CT2E104HJE06
C603	CERAMIC CAP.(AX) B K 470pF/50V	CCA1JKT0B471
C605	CERAMIC CAP. F Z 0.01µF/500V or	CCD2JZP0F103
	CERAMIC CAP. 0.01µF/AC250V	CCD2EZA0F103
C606	CERAMIC CAP. F Z 0.01µF/500V or	CCD2JZP0F103
	CERAMIC CAP. 0.01µF/AC250V	CCD2EZA0F103
C609	CERAMIC CAP. B K 680pF/2KV or	CCD3DKD0B681
	CERAMIC CAP. B K 680pF/2KV	CCD3DKP0B681
C610▲	ELECTROLYTIC CAP. 470µF/200V M or	CE2DMZNTL471
▲	ELECTROLYTIC CAP. 470µF/200V M or	CE2DMZNDL471
▲	ELECTROLYTIC CAP. 470µF/200V	CA2D471NC013
C611	FILM CAP.(P) 0.068µF/50V J or	CMA1JJS00683
	FILM CAP.(P) 0.068µF/50V J or	CA1J683MS029
	FILM CAP.(P) 0.068µF/50V J TV or	CMB1JJS00683
	MYLAR CAP. 0.068µF/50V K	2250683S
C613	FILM CAP.(P) 0.056µF/50V J or	CMA1JJS00563
	FILM CAP.(P) 0.056µF/50V J or	CA1J563MS029
	FILM CAP.(P) 0.056µF/50V J TV or	CMB1JJS00563
	MYLAR CAP. 0.056µF/50V KT	2250563S
C615	CERAMIC CAP.(AX) B K 100pF/50V	CCA1JKT0B101
C616	FILM CAP.(P) 0.1µF/50V J or	CMA1JJS00104
	FILM CAP.(P) 0.1µF/50V J or	CA1J104MS029
	FILM CAP.(P) 0.1µF/50V J TV or	CMB1JJS00104
	MYLAR CAP. 0.1µF/50V K	2250104S
C618	FILM CAP.(P) 0.1µF/50V J or	CMA1JJS00104
	FILM CAP.(P) 0.1µF/50V J or	CA1J104MS029
	FILM CAP.(P) 0.1µF/50V J TV or	CMB1JJS00104
	MYLAR CAP. 0.1µF/50V K	2250104S
C642▲	SAFETY CAP. 4700pF/250V or	CCG2EMA0F472
▲	SAFETY CAP. E M 4700pF/250V KH or	CCG2EMP0E472
▲	CERAMIC CAP. 0.0047µF F CS	CCG2HMN0F472
C650	CERAMIC CAP. LB 560pF/2KV or	CA3D561KG004
	CERAMIC CAP. BN 560pF/2KV or	CCD3DKA0B561
	CERAMIC CAP. 560pF/2KV	CA3D561PAN04
C654	ELECTROLYTIC CAP. 1µF/50V M or	CE1JMASTL1R0
	ELECTROLYTIC CAP. 1µF/50V M or	CE1JMASTL010
	ELECTROLYTIC CAP. 1µF/50V M or	CE1JMASDL1R0
	ELECTROLYTIC CAP. 1µF/50V M	CE1JMASDL010
C656	ELECTROLYTIC CAP. 100µF/160V M W/F or	CE2CMZNTL101

Ref. No.	Description	Part No.
	ELECTROLYTIC CAP. 100µF/160V M	CE2CMZPDL101
C657▲	ELECTROLYTIC CAP. 2200µF/35V M or	CE1GMZNTL222
▲	ELECTROLYTIC CAP. 2200µF/35V M	CE1GMZNDL222
C658▲	ELECTROLYTIC CAP. 1000µF/16V M(VR/HC) or	CE1CMZNTL102
▲	ELECTROLYTIC CAP. 1000µF/16V M or	CE1CMZNDL102
▲	ELECTROLYTIC CAP. 1000µF/16V M	CE1CMZAD102
C661	CERAMIC CAP.(AX) F Z 0.01µF/25V	CDA1EZT0F103
C662▲	ELECTROLYTIC CAP. 1000µF/25V M or	CE1EMZNTL102
▲	ELECTROLYTIC CAP. 1000µF/25V M	CE1EMZPDL102
C667	ELECTROLYTIC CAP. 1µF/50V M or	CE1JMASTL1R0
	ELECTROLYTIC CAP. 1µF/50V M or	CE1JMASTL010
	ELECTROLYTIC CAP. 1µF/50V M or	CE1JMASDL1R0
	ELECTROLYTIC CAP. 1µF/50V M	CE1JMASDL010
C681	ELECTROLYTIC CAP. 10µF/50V M or	CE1JMASTL100
	ELECTROLYTIC CAP. 10µF/50V M	CE1JMASDL100
C682	ELECTROLYTIC CAP. 100µF/10V M or	CE1AMASTL101
	ELECTROLYTIC CAP. 100µF/10V M	CE1AMASDL101
C684	ELECTROLYTIC CAP. 470µF/10V M or	CE1AMASTL471
	ELECTROLYTIC CAP. 470µF/10V M	CE1AMASDL471
C685	ELECTROLYTIC CAP. 1000µF/10V M or	CE1AMASTL102
	ELECTROLYTIC CAP. 1000µF/10V M	CE1AMASDL102
C686	ELECTROLYTIC CAP. 100µF/10V M or	CE1AMASTL101
	ELECTROLYTIC CAP. 100µF/10V M	CE1AMASDL101
C701	CERAMIC CAP.(AX) B K 100pF/50V	CCA1JKT0B101
C702	PCB JUMPER D0.6-P5.0	JW5.0T
C705	CERAMIC CAP.(AX) X K 6800pF/16V	CDA1CKT0X682
C706	ELECTROLYTIC CAP. 0.47µF/50V M or	CE1JMASTLR47
	ELECTROLYTIC CAP. 0.47µF/50V M	CE1JMASDLR47
C708	CERAMIC CAP.(AX) X K 6800pF/16V	CDA1CKT0X682
C709	ELECTROLYTIC CAP. 0.47µF/50V M or	CE1JMASTLR47
	ELECTROLYTIC CAP. 0.47µF/50V M	CE1JMASDLR47
C713	ELECTROLYTIC CAP. 10µF/50V M or	CE1JMASTL100
	ELECTROLYTIC CAP. 10µF/50V M	CE1JMASDL100
C718	CERAMIC CAP.(AX) B K 1000pF/50V	CCA1JKT0B102
C721	CERAMIC CAP.(AX) B K 100pF/50V	CCA1JKT0B101
C722	ELECTROLYTIC CAP. 10µF/50V M or	CE1JMASTL100
	ELECTROLYTIC CAP. 10µF/50V M	CE1JMASDL100
C725	CERAMIC CAP.(AX) X K 6800pF/16V	CDA1CKT0X682
C726	ELECTROLYTIC CAP. 0.47µF/50V M	CE1JMASTLR47
C728	CERAMIC CAP.(AX) X K 6800pF/16V or	CDA1CKT0X682
	CERAMIC CAP.(AX) X K 3300pF/16V	CDA1CKT0X332
C729	ELECTROLYTIC CAP. 0.47µF/50V M or	CE1JMASTLR47
	ELECTROLYTIC CAP. 0.47µF/50V M	CE1JMASDLR47
C751	ELECTROLYTIC CAP. 1µF/50V M or	CE1JMASTL1R0
	ELECTROLYTIC CAP. 1µF/50V M or	CE1JMASTL010
	ELECTROLYTIC CAP. 1µF/50V M or	CE1JMASDL1R0
	ELECTROLYTIC CAP. 1µF/50V M	CE1JMASDL010
C757	ELECTROLYTIC CAP. 0.1µF/50V M or	CE1JMASTLR10
	ELECTROLYTIC CAP. 0.1µF/50V M	CE1JMASDLR10
C761	ELECTROLYTIC CAP. 1µF/50V M or	CE1JMASTL1R0
	ELECTROLYTIC CAP. 1µF/50V M or	CE1JMASTL010
	ELECTROLYTIC CAP. 1µF/50V M or	CE1JMASDL1R0
	ELECTROLYTIC CAP. 1µF/50V M	CE1JMASDL010
C767	ELECTROLYTIC CAP. 0.1µF/50V M or	CE1JMASTLR10
	ELECTROLYTIC CAP. 0.1µF/50V M	CE1JMASDLR10
C773	ELECTROLYTIC CAP. 100µF/10V M or	CE1AMASTL101
	ELECTROLYTIC CAP. 100µF/10V M	CE1AMASDL101
C781	ELECTROLYTIC CAP. 10µF/50V M or	CE1JMASTL100
	ELECTROLYTIC CAP. 10µF/50V M	CE1JMASDL100
C801	ELECTROLYTIC CAP. 470µF/25V M or	CE1EMASTL471
	ELECTROLYTIC CAP. 470µF/25V M	CE1EMASDL471

Ref. No.	Description	Part No.
C802	ELECTROLYTIC CAP. 470µF/25V M or ELECTROLYTIC CAP. 470µF/25V M	CE1EMASTL471 CE1EMASDL471
C803	FILM CAP.(P) 0.1µF/50V J or FILM CAP.(P) 0.1µF/50V J or FILM CAP.(P) 0.1µF/50V J TV or MYLAR CAP. 0.1µF/50V K	CMA1JJS00104 CA1J104MS029 CMB1JJS00104 2250104S
C804	FILM CAP.(P) 0.1µF/50V J or FILM CAP.(P) 0.1µF/50V J or FILM CAP.(P) 0.1µF/50V J TV or MYLAR CAP. 0.1µF/50V K	CMA1JJS00104 CA1J104MS029 CMB1JJS00104 2250104S
C808	ELECTROLYTIC CAP. 1µF/50V M or ELECTROLYTIC CAP. 1µF/50V M or ELECTROLYTIC CAP. 1µF/50V M or ELECTROLYTIC CAP. 1µF/50V M	CE1JMASTL1R0 CE1JMASTL010 CE1JMASDL1R0 CE1JMASDL010
C809	ELECTROLYTIC CAP. 1µF/50V M or ELECTROLYTIC CAP. 1µF/50V M or ELECTROLYTIC CAP. 1µF/50V M or ELECTROLYTIC CAP. 1µF/50V M	CE1JMASTL1R0 CE1JMASTL010 CE1JMASDL1R0 CE1JMASDL010
C812	ELECTROLYTIC CAP. 10µF/50V M or ELECTROLYTIC CAP. 10µF/50V M	CE1JMASTL100 CE1JMASDL100
C814	ELECTROLYTIC CAP. 22µF/50V M or ELECTROLYTIC CAP. 22µF/50V M	CE1JMASTL220 CE1JMASDL220
C821	ELECTROLYTIC CAP. 1000µF/25V M or ELECTROLYTIC CAP. 1000µF/25V M	CE1EMZNTL102 CE1EMZPDL102
C827	ELECTROLYTIC CAP. 100µF/16V M or ELECTROLYTIC CAP. 100µF/16V M	CE1CMASTL101 CE1CMASDL101
C831	ELECTROLYTIC CAP. 100µF/25V M or ELECTROLYTIC CAP. 100µF/25V M	CE1EMASTL101 CE1EMASDL101
C851	ELECTROLYTIC CAP. 10µF/50V M or ELECTROLYTIC CAP. 10µF/50V M	CE1JMASTL100 CE1JMASDL100
C852	ELECTROLYTIC CAP. 470µF/16V M or ELECTROLYTIC CAP. 470µF/16V M	CE1CMASTL471 CE1CMASDL471
C853	CERAMIC CAP.(AX) F Z 0.01µF/25V	CDA1EZT0F103
C963	ELECTROLYTIC CAP. 10µF/50V M or ELECTROLYTIC CAP. 10µF/50V M	CE1JMASTL100 CE1JMASDL100
C964▲	ELECTROLYTIC CAP. 100µF/10V M or ▲ ELECTROLYTIC CAP. 100µF/10V M	CE1AMASTL101 CE1AMASDL101
<b>CONNECTORS</b>		
CN301	CONNECTOR BASE, 6P TUC-P06P-B1	J3TUA06TG001
CN571▲	CONNECTOR BASE, 5P TV-50P-05-V3 or ▲ CONNECTOR BASE, 5P RTB-1.5-5P or ▲ CONNECTOR BASE, 5P W-P3005-02	J3TVC05TG002 J3RTC05JG001 1730812
CN691▲	CONNECTOR BASE, 2P TV-50P-02-V3 or ▲ CONNECTOR BASE, 2P RTB-1.5-2P	J3TVC02TG002 J3RTC02JG001
CN801	STRAIGHT CONNECTOR BASE 00 8283 0212 00 000 or STRAIGHT PIN HEADER, 2P 173981-2	J383C02UG002 1770258
CN802	STRAIGHT CONNECTOR BASE 00 8283 0212 00 000 or STRAIGHT PIN HEADER, 2P 173981-2	J383C02UG002 1770258
<b>DIODES</b>		
D131	ZENER DIODE MTZJT-775.1B or ZENER DIODE DZ-5.1BSBT265	QDTB0MTZJ5R1 NDTB0DZ5R1BS
D171	SWITCHING DIODE 1SS133(T-77) or SWITCHING DIODE 1N4148 or DIODE 1SS176TPA7	QDTZ001SS133 NDTZ001N4148 1SS176T
D322	SWITCHING DIODE 1SS133(T-77) or SWITCHING DIODE 1N4148 or DIODE 1SS176TPA7	QDTZ001SS133 NDTZ001N4148 1SS176T
D323	ZENER DIODE MTZJT-779.1B or ZENER DIODE DZ-9.1BSBT265	QDTB0MTZJ9R1 NDTB0DZ9R1BS

Ref. No.	Description	Part No.
D326	SWITCHING DIODE 1SS133(T-77) or SWITCHING DIODE 1N4148 or DIODE 1SS176TPA7	QDTZ001SS133 NDTZ001N4148 1SS176T
D351	SWITCHING DIODE 1SS133(T-77) or SWITCHING DIODE 1N4148 or DIODE 1SS176TPA7	QDTZ001SS133 NDTZ001N4148 1SS176T
D352	SWITCHING DIODE 1SS133(T-77) or SWITCHING DIODE 1N4148 or DIODE 1SS176TPA7	QDTZ001SS133 NDTZ001N4148 1SS176T
D353	SWITCHING DIODE 1SS133(T-77) or SWITCHING DIODE 1N4148 or DIODE 1SS176TPA7	QDTZ001SS133 NDTZ001N4148 1SS176T
D501	DIODE FR104-B or RECTIFIER DIODE ERA22-02 or RECTIFIER DIODE 10ELS2	NDLZ000FR104 QDPZ0ERA2202 QDQZ0010ELS2
D502▲	ZENER DIODE MTZJT-7724B or ▲ ZENER DIODE DZ-24BSBT265	QDTB00MTZJ24 NDTB00DZ24BS
D503▲	SWITCHING DIODE 1SS133(T-77) or ▲ SWITCHING DIODE 1N4148 or ▲ DIODE 1SS176TPA7	QDTZ001SS133 NDTZ001N4148 1SS176T
D545	ZENER DIODE MTZJT-776.8B or ZENER DIODE DZ-6.8BSBT265	QDTB0MTZJ6R8 NDTB0DZ6R8BS
D546	SWITCHING DIODE 1SS133(T-77) or SWITCHING DIODE 1N4148 or DIODE 1SS176TPA7	QDTZ001SS133 NDTZ001N4148 1SS176T
D547	SWITCHING DIODE 1SS133(T-77) or SWITCHING DIODE 1N4148 or DIODE 1SS176TPA7	QDTZ001SS133 NDTZ001N4148 1SS176T
D552▲	ZENER DIODE MTZJT-773.0B or ▲ ZENER DIODE DZ-3.0BSBT265	QDTB0MTZJ3R0 NDTB0DZ3R0BS
D558	SWITCHING DIODE 1SS133(T-77) or SWITCHING DIODE 1N4148 or DIODE 1SS176TPA7	QDTZ001SS133 NDTZ001N4148 1SS176T
D572	RECTIFIER DIODE ERA22-02 or RECTIFIER DIODE 10ELS2	QDPZ0ERA2202 QDQZ0010ELS2
D573	RECTIFIER DIODE ERA22-02 or RECTIFIER DIODE 10ELS2	QDPZ0ERA2202 QDQZ0010ELS2
D580▲	DIODE ERD07-15	QDLZ0ERD0715
D582	FAST RECOVERY DIODE ERD38-06	QDQZ0ERD3806
D583	SWITCHING DIODE 1SS133(T-77) or SWITCHING DIODE 1N4148 or DIODE 1SS176TPA7	QDTZ001SS133 NDTZ001N4148 1SS176T
D584▲	SWITCHING DIODE 1SS133(T-77) or ▲ SWITCHING DIODE 1N4148 or ▲ DIODE 1SS176TPA7	QDTZ001SS133 NDTZ001N4148 1SS176T
D585	SWITCHING DIODE 1SS133(T-77) or SWITCHING DIODE 1N4148 or DIODE 1SS176TPA7	QDTZ001SS133 NDTZ001N4148 1SS176T
D591▲	ZENER DIODE MTZJT-7736B or ▲ ZENER DIODE DZ-36BSBT265	QDTB00MTZJ36 NDTB00DZ36BS
D594▲	SWITCHING DIODE 1SS133(T-77) or ▲ SWITCHING DIODE 1N4148 or ▲ DIODE 1SS176TPA7	QDTZ001SS133 NDTZ001N4148 1SS176T
D597	ZENER DIODE MTZJT-776.8B or ZENER DIODE DZ-6.8BSBT265	QDTB0MTZJ6R8 NDTB0DZ6R8BS
D605▲	DIODE 1N5406	NDLZ001N5406
D606▲	DIODE 1N5406	NDLZ001N5406
D607▲	DIODE 1N5406	NDLZ001N5406
D608▲	DIODE 1N5406	NDLZ001N5406
D609	SWITCHING DIODE 1SS133(T-77) or SWITCHING DIODE 1N4148 or	QDTZ001SS133 NDTZ001N4148

Ref. No.	Description	Part No.
	DIODE 1SS176TPA7	1SS176T
D611▲	ZENER DIODE MTZJT-7720B or	QDTB00MTZJ20
▲	ZENER DIODE DZ-20BSBT265	NDTB00DZ20BS
D613	ZENER DIODE MTZJT-778.2B or	QDTB00MTZJ8R2
	ZENER DIODE DZ-8.2BSBT265	NDTB00DZ8R2BS
D614	SWITCHING DIODE 1SS133(T-77) or	QDTZ001SS133
	SWITCHING DIODE 1N4148 or	NDTZ001N4148
	DIODE 1SS176TPA7	1SS176T
D615	SWITCHING DIODE 1N4148 T-77	QDTZ001N4148
D621	BEAD INDUCTORS FBA04HA600VB-00	LLBF00STU026
D651▲	FAST RECOVERY DIODE 30DF6 or	QDWZ00030DF6
▲	DIODE ERD29-06J or	QD4Z0ERD2906
▲	FAST RECOVERY DIODE FE201-6	QDLZ00FE2016
D652▲	DIODE FR154 or	NDLZ000FR154
▲	FAST RECOVERY DIODE ERB44-02	QDPZ0ERB4402
D653▲	DIODE FR154 or	NDLZ000FR154
▲	FAST RECOVERY DIODE ERB44-02	QDPZ0ERB4402
D654▲	SWITCHING DIODE 1SS133(T-77) or	QDTZ001SS133
▲	SWITCHING DIODE 1N4148 or	NDTZ001N4148
▲	DIODE 1SS176TPA7	1SS176T
D655	ZENER DIODE 1ZB180	QDQZ001ZB180
D656▲	ZENER DIODE MTZJT-776.8B or	QDTB00MTZJ6R8
▲	ZENER DIODE DZ-6.8BSBT265	NDTB00DZ6R8BS
D657▲	DIODE FR154 or	NDLZ000FR154
▲	FAST RECOVERY DIODE ERB44-02	QDPZ0ERB4402
D658▲	DIODE 1ZC18 or	QDQZ0001ZC18
▲	ZENER DIODE RD18F	QDQZ000RD18F
D660	SWITCHING DIODE 1SS133(T-77) or	QDTZ001SS133
	SWITCHING DIODE 1N4148 or	NDTZ001N4148
	DIODE 1SS176TPA7	1SS176T
D661	SWITCHING DIODE 1SS133(T-77) or	QDTZ001SS133
	SWITCHING DIODE 1N4148 or	NDTZ001N4148
	DIODE 1SS176TPA7	1SS176T
D666	ZENER DIODE MTZJT-7736B or	QDTB00MTZJ36
	ZENER DIODE DZ-36BSBT265	NDTB00DZ36BS
D671▲	SWITCHING DIODE 1SS133(T-77) or	QDTZ001SS133
▲	SWITCHING DIODE 1N4148 or	NDTZ001N4148
▲	DIODE 1SS176TPA7	1SS176T
D672	SWITCHING DIODE 1SS133(T-77) or	QDTZ001SS133
	SWITCHING DIODE 1N4148 or	NDTZ001N4148
	DIODE 1SS176TPA7	1SS176T
D673	SWITCHING DIODE 1SS133(T-77) or	QDTZ001SS133
	SWITCHING DIODE 1N4148 or	NDTZ001N4148
	DIODE 1SS176TPA7	1SS176T
D675▲	SWITCHING DIODE 1SS133(T-77) or	QDTZ001SS133
▲	SWITCHING DIODE 1N4148 or	NDTZ001N4148
▲	DIODE 1SS176TPA7	1SS176T
D692▲	SWITCHING DIODE 1SS133(T-77) or	QDTZ001SS133
▲	SWITCHING DIODE 1N4148 or	NDTZ001N4148
▲	DIODE 1SS176TPA7	1SS176T
D694▲	ZENER DIODE MTZJT-7715B or	QDTB00MTZJ15
▲	ZENER DIODE DZ-15BSBT265	NDTB00DZ15BS
D696	SWITCHING DIODE 1SS133(T-77) or	QDTZ001SS133
	SWITCHING DIODE 1N4148 or	NDTZ001N4148
	DIODE 1SS176TPA7	1SS176T
D697▲	SWITCHING DIODE 1SS133(T-77) or	QDTZ001SS133
▲	SWITCHING DIODE 1N4148 or	NDTZ001N4148
▲	DIODE 1SS176TPA7	1SS176T
D698▲	SWITCHING DIODE 1SS133(T-77) or	QDTZ001SS133
▲	SWITCHING DIODE 1N4148 or	NDTZ001N4148
▲	DIODE 1SS176TPA7	1SS176T

Ref. No.	Description	Part No.
D826	SWITCHING DIODE 1SS133(T-77) or	QDTZ001SS133
	SWITCHING DIODE 1N4148 or	NDTZ001N4148
	DIODE 1SS176TPA7	1SS176T
D827	SWITCHING DIODE 1SS133(T-77) or	QDTZ001SS133
	SWITCHING DIODE 1N4148 or	NDTZ001N4148
	DIODE 1SS176TPA7	1SS176T
D841▲	SWITCHING DIODE 1SS133(T-77) or	QDTZ001SS133
▲	SWITCHING DIODE 1N4148 or	NDTZ001N4148
▲	DIODE 1SS176TPA7	1SS176T
D842▲	ZENER DIODE MTZJT-776.2B or	QDTB00MTZJ6R2
▲	ZENER DIODE DZ-6.2BSBT265	NDTB00DZ6R2BS
D851▲	ZENER DIODE MTZJT-7712B or	QDTB00MTZJ12
▲	ZENER DIODE DZ-12BSBT265	NDTB00DZ12BS
D853	ZENER DIODE MTZJT-779.1B or	QDTB00MTZJ9R1
	ZENER DIODE DZ-9.1BSBT265	NDTB00DZ9R1BS
D854	SWITCHING DIODE 1SS133(T-77) or	QDTZ001SS133
	SWITCHING DIODE 1N4148 or	NDTZ001N4148
	DIODE 1SS176TPA7	1SS176T
D855	SWITCHING DIODE 1SS133(T-77) or	QDTZ001SS133
	SWITCHING DIODE 1N4148 or	NDTZ001N4148
	DIODE 1SS176TPA7	1SS176T
D896	SWITCHING DIODE 1SS133(T-77) or	QDTZ001SS133
	SWITCHING DIODE 1N4148 or	NDTZ001N4148
	DIODE 1SS176TPA7	1SS176T
D963	ZENER DIODE MTZJT-775.6B or	QDTB00MTZJ5R6
	ZENER DIODE DZ-5.6BSBT265	NDTB00DZ5R6BS
D966	SWITCHING DIODE 1SS133(T-77) or	QDTZ001SS133
	SWITCHING DIODE 1N4148 or	NDTZ001N4148
	DIODE 1SS176TPA7	1SS176T
<b>ICS</b>		
IC33	IC:VIF/SIF DETECTOR M61111FP	QSZBA0SMB010
IC151	IC:MEMORY AT24C02N-10SC or	NSMMA0SAZ012
	IC(EEPROM) M24C02-MN6 or	NSMMA0SSS028
	IC:MEMORY BR24C02F-W or	QSMBA0SRM003
	IC:MEMORY BR24C02F or	QSMMA0SRM003
	IC:MEMORY S524C20D21 or	NSZBA0SSM028
	IC(EEP-ROM) M24C02-WMN6	NSZAA0SSS004
IC333	IC M61272M8-054FP	QSZAA0RMB130
IC431	IC:MTS RECORDER AN5832SA	QSZBA0TMS003
IC551▲	IC:VERTICAL OUTPUT LA78041	QSZBA0SSY006
IC601▲	PHOTOCOUPLER LTV-817B-F or	NPEB0LTV817F
▲	PHOTOCOUPLER LTV-817C-F	NPEC0LTV817F
IC771	IC:SWITCHING TC4052BF(EL) or	QSZBA0TSS096
	IC:SWITCHING CD4052BCSJX	NSZBA0TF3079
IC801	AUDIO POWER IC AN17805A	QSZBA0SMS007
<b>COILS</b>		
L1	PCB JUMPER D0.6-P5.0	JW5.0T
L2	INDUCTOR 22μH-K-5FT or	LLARKBSTU220
	INDUCTOR 22μH-K	LLARKDQKA220
L32	INDUCTOR 15μH-J-26T or	LLAXJATTU150
	INDUCTOR 15μH-K-26T	LLAXKDTKA150
L33	INDUCTOR 22μH-J-26T or	LLAXJATTU220
	INDUCTOR 22μH-K-26T	LLAXKDTKA220
L34	PCB JUMPER D0.6-P5.0	JW5.0T
L51	INDUCTOR 100μH-J-5FT or	LLARJCASTU101
	INDUCTOR 100μH-K	LLARKDQKA101
L111	INDUCTOR 22μH-K-5FT or	LLARKBSTU220
	INDUCTOR 22μH-K	LLARKDQKA220
L112	INDUCTOR 22μH-K-5FT or	LLARKBSTU220
	INDUCTOR 22μH-K	LLARKDQKA220



Ref. No.	Description	Part No.
L301	INDUCTOR 100μH-J-5FT or	LLARJCSU101
	INDUCTOR 100μH-K	LLARKDQKA101
L341	PCB JUMPER D0.6-P5.0	JW5.0T
L342	PCB JUMPER D0.6-P5.0	JW5.0T
L551▲	LINEARITY COIL ELH5L6136N	LLBD00PMS008
L562▲	CHOKE COIL ELC18B681LK or	LLC681KMS001
▲	CHOKE COIL CSA-LF057	LLBD00ZSA001
L588	CHOKE COIL 47μH-K or	LLBD00PKV007
	POT COIL 47μH K	LLBD**DMM001
L601▲	LINE FILTER MS036 or	LLBG00ZY2009
▲	LINE FILTER JLB2808	LLBG00ZXB004
<b>TRANSISTORS</b>		
Q21	TRANSISTOR 2SA1175(F) or	QQSF02SA1175
	TRANSISTOR KTA1267(GR) or	NQS10KTA1267
	TRANSISTOR KTA1266(GR) or	NQS40KTA1266
	TRANSISTOR 2SA1318(T)-AANP or	2SA1318TZ
	TRANSISTOR 2SA1318(U)-AANP or	2SA1318UZ
	TRANSISTOR 2SA1015-GR(TPE2)	QQS102SA1015
Q33	TRANSISTOR 2SC2785(F) or	QQSF02SC2785
	TRANSISTOR 2SC2785(H) or	QQSH02SC2785
	TRANSISTOR 2SC2785(J) or	QQSJ02SC2785
	TRANSISTOR KTC3199(GR) or	NQS10KTC3199
	TRANSISTOR KTC3198(GR) or	NQS40KTC3198
	TRANSISTOR 2SC3331(T)-AANP or	2SC3331TZ
	TRANSISTOR 2SC3331(U)-AANP or	2SC3331UZ
	TRANSISTOR 2SC1815-GR(TPE2)	QQS102SC1815
Q111▲	TRANSISTOR 2SC2785(F) or	QQSF02SC2785
▲	TRANSISTOR 2SC2785(H) or	QQSH02SC2785
▲	TRANSISTOR 2SC2785(J) or	QQSJ02SC2785
▲	TRANSISTOR KTC3199(GR) or	NQS10KTC3199
▲	TRANSISTOR KTC3198(GR) or	NQS40KTC3198
▲	TRANSISTOR 2SC3331(T)-AANP or	2SC3331TZ
▲	TRANSISTOR 2SC3331(U)-AANP or	2SC3331UZ
▲	TRANSISTOR 2SC1815-GR(TPE2)	QQS102SC1815
Q131	RES. BUILT-IN TRANSISTOR BA1F4M-T or	QQSZ00BA1F4M
	RES. BUILT-IN TRANSISTOR KRC103M	NQSZ0KRC103M
Q141	RES. BUILT-IN TRANSISTOR BA1F4M-T or	QQSZ00BA1F4M
	RES. BUILT-IN TRANSISTOR KRC103M	NQSZ0KRC103M
Q191	TRANSISTOR 2SC2785(F) or	QQSF02SC2785
	TRANSISTOR 2SC2785(H) or	QQSH02SC2785
	TRANSISTOR 2SC2785(J) or	QQSJ02SC2785
	TRANSISTOR KTC3199(GR) or	NQS10KTC3199
	TRANSISTOR KTC3198(GR) or	NQS40KTC3198
	TRANSISTOR 2SC3331(T)-AANP or	2SC3331TZ
	TRANSISTOR 2SC3331(U)-AANP or	2SC3331UZ
	TRANSISTOR 2SC1815-GR(TPE2)	QQS102SC1815
Q321	TRANSISTOR 2SC2785(F) or	QQSF02SC2785
	TRANSISTOR 2SC2785(H) or	QQSH02SC2785
	TRANSISTOR 2SC2785(J) or	QQSJ02SC2785
	TRANSISTOR KTC3199(GR) or	NQS10KTC3199
	TRANSISTOR KTC3198(GR) or	NQS40KTC3198
	TRANSISTOR 2SC3331(T)-AANP or	2SC3331TZ
	TRANSISTOR 2SC3331(U)-AANP or	2SC3331UZ
	TRANSISTOR 2SC1815-GR(TPE2)	QQS102SC1815
Q531	TRANSISTOR 2SC2785(F) or	QQSF02SC2785
	TRANSISTOR 2SC2785(H) or	QQSH02SC2785
	TRANSISTOR 2SC2785(J) or	QQSJ02SC2785
	TRANSISTOR KTC3199(GR) or	NQS10KTC3199
	TRANSISTOR KTC3198(GR) or	NQS40KTC3198
	TRANSISTOR 2SC3331(T)-AANP or	2SC3331TZ

Ref. No.	Description	Part No.
	TRANSISTOR 2SC3331(U)-AANP or	2SC3331UZ
	TRANSISTOR 2SC1815-GR(TPE2)	QQS102SC1815
Q533	TRANSISTOR 2SC2785(F) or	QQSF02SC2785
	TRANSISTOR 2SC2785(H) or	QQSH02SC2785
	TRANSISTOR 2SC2785(J) or	QQSJ02SC2785
	TRANSISTOR KTC3199(GR) or	NQS10KTC3199
	TRANSISTOR KTC3198(GR) or	NQS40KTC3198
	TRANSISTOR 2SC3331(T)-AANP or	2SC3331TZ
	TRANSISTOR 2SC3331(U)-AANP or	2SC3331UZ
	TRANSISTOR 2SC1815-GR(TPE2)	QQS102SC1815
Q547	TRANSISTOR 2SC2785(F) or	QQSF02SC2785
	TRANSISTOR 2SC2785(H) or	QQSH02SC2785
	TRANSISTOR 2SC2785(J) or	QQSJ02SC2785
	TRANSISTOR KTC3199(GR) or	NQS10KTC3199
	TRANSISTOR KTC3198(GR) or	NQS40KTC3198
	TRANSISTOR 2SC3331(T)-AANP or	2SC3331TZ
	TRANSISTOR 2SC3331(U)-AANP or	2SC3331UZ
	TRANSISTOR 2SC1815-GR(TPE2)	QQS102SC1815
Q551▲	TRANSISTOR 2SA1175(F) or	QQSF02SA1175
▲	TRANSISTOR KTA1267(GR) or	NQS10KTA1267
▲	TRANSISTOR KTA1266(GR) or	NQS40KTA1266
▲	TRANSISTOR 2SA1318(T)-AANP or	2SA1318TZ
▲	TRANSISTOR 2SA1318(U)-AANP or	2SA1318UZ
▲	TRANSISTOR 2SA1015-GR(TPE2)	QQS102SA1015
Q552▲	TRANSISTOR KTD2059(O) or	NQ400KTD2059
▲	TRANSISTOR KTD2059(Y) or	NQ4Y0KTD2059
▲	TRANSISTOR 2SD1666S	QQE502SD1666
Q561	TRANSISTOR 2SC2785(F) or	QQSF02SC2785
	TRANSISTOR 2SC2785(H) or	QQSH02SC2785
	TRANSISTOR 2SC2785(J) or	QQSJ02SC2785
	TRANSISTOR KTC3199(GR) or	NQS10KTC3199
	TRANSISTOR KTC3198(GR) or	NQS40KTC3198
	TRANSISTOR 2SC3331(T)-AANP or	2SC3331TZ
	TRANSISTOR 2SC3331(U)-AANP or	2SC3331UZ
	TRANSISTOR 2SC1815-GR(TPE2)	QQS102SC1815
Q571▲	TRANSISTOR 2SD2553 or	QQWZ02SD2553
▲	TRANSISTOR 2SC5902	QQWZ02SC5902
Q572▲	TRANSISTOR 2SC1627Y-TPE2	QQSY02SC1627
Q601▲	FET 2SK3407	QFFZ02SK3407
Q602▲	TRANSISTOR 2SC2120-O-TPE2 or	QQS002SC2120
▲	TRANSISTOR 2SC2120-Y(TPE2)	QQSY02SC2120
Q652▲	TRANSISTOR 2SC2785(F) or	QQSF02SC2785
▲	TRANSISTOR 2SC2785(H) or	QQSH02SC2785
▲	TRANSISTOR 2SC2785(J) or	QQSJ02SC2785
▲	TRANSISTOR KTC3199(GR) or	NQS10KTC3199
▲	TRANSISTOR KTC3198(GR) or	NQS40KTC3198
▲	TRANSISTOR 2SC3331(T)-AANP or	2SC3331TZ
▲	TRANSISTOR 2SC3331(U)-AANP or	2SC3331UZ
▲	TRANSISTOR 2SC1815-GR(TPE2)	QQS102SC1815
Q672▲	TRANSISTOR 2SA950(O)	Q2SA9500TPE2
Q673	TRANSISTOR 2SC2785(F) or	QQSF02SC2785
	TRANSISTOR 2SC2785(H) or	QQSH02SC2785
	TRANSISTOR 2SC2785(J) or	QQSJ02SC2785
	TRANSISTOR KTC3199(GR) or	NQS10KTC3199
	TRANSISTOR KTC3198(GR) or	NQS40KTC3198
	TRANSISTOR 2SC3331(T)-AANP or	2SC3331TZ
	TRANSISTOR 2SC3331(U)-AANP or	2SC3331UZ
	TRANSISTOR 2SC1815-GR(TPE2)	QQS102SC1815
Q674	TRANSISTOR 2SC2785(F) or	QQSF02SC2785
	TRANSISTOR 2SC2785(H) or	QQSH02SC2785
	TRANSISTOR 2SC2785(J) or	QQSJ02SC2785

Ref. No.	Description	Part No.
	TRANSISTOR KTC3199(GR) or	NQS10KTC3199
	TRANSISTOR KTC3198(GR) or	NQS40KTC3198
	TRANSISTOR 2SC3331(T)-AANP or	2SC3331TZ
	TRANSISTOR 2SC3331(U)-AANP or	2SC3331UZ
	TRANSISTOR 2SC1815-GR(TPE2)	QQS102SC1815
Q681	TRANSISTOR 2SC2120-O-TPE2 or	QQS002SC2120
	TRANSISTOR 2SC2120-Y(TPE2) or	QQSY02SC2120
	TRANSISTOR KTC3203(Y)	NQSY0KTC3203
Q682	TRANSISTOR 2SC2120-O-TPE2 or	QQS002SC2120
	TRANSISTOR 2SC2120-Y(TPE2) or	QQSY02SC2120
	TRANSISTOR KTC3203(Y)	NQSY0KTC3203
Q683	TRANSISTOR 2SC2120-O-TPE2 or	QQS002SC2120
	TRANSISTOR 2SC2120-Y(TPE2) or	QQSY02SC2120
	TRANSISTOR KTC3203(Y)	NQSY0KTC3203
Q696	RES. BUILT-IN TRANSISTOR BA1F4M-T or	QQSZ00BA1F4M
	RES. BUILT-IN TRANSISTOR KRC103M	NQSZ0KRC103M
Q751	TRANSISTOR 2SC2785(F) or	QQSF02SC2785
	TRANSISTOR 2SC2785(H) or	QQSH02SC2785
	TRANSISTOR 2SC2785(J) or	QQSJ02SC2785
	TRANSISTOR KTC3199(GR) or	NQS10KTC3199
	TRANSISTOR KTC3198(GR) or	NQS40KTC3198
	TRANSISTOR 2SC3331(T)-AANP or	2SC3331TZ
	TRANSISTOR 2SC3331(U)-AANP or	2SC3331UZ
	TRANSISTOR 2SC1815-GR(TPE2)	QQS102SC1815
Q761	TRANSISTOR 2SC2785(F) or	QQSF02SC2785
	TRANSISTOR 2SC2785(H) or	QQSH02SC2785
	TRANSISTOR 2SC2785(J) or	QQSJ02SC2785
	TRANSISTOR KTC3199(GR) or	NQS10KTC3199
	TRANSISTOR KTC3198(GR) or	NQS40KTC3198
	TRANSISTOR 2SC3331(T)-AANP or	2SC3331TZ
	TRANSISTOR 2SC3331(U)-AANP or	2SC3331UZ
	TRANSISTOR 2SC1815-GR(TPE2)	QQS102SC1815
Q791	TRANSISTOR 2SC2785(F) or	QQSF02SC2785
	TRANSISTOR 2SC2785(H) or	QQSH02SC2785
	TRANSISTOR 2SC2785(J) or	QQSJ02SC2785
	TRANSISTOR KTC3199(GR) or	NQS10KTC3199
	TRANSISTOR KTC3198(GR) or	NQS40KTC3198
	TRANSISTOR 2SC3331(T)-AANP or	2SC3331TZ
	TRANSISTOR 2SC3331(U)-AANP or	2SC3331UZ
	TRANSISTOR 2SC1815-GR(TPE2)	QQS102SC1815
Q792	TRANSISTOR 2SC2785(F) or	QQSF02SC2785
	TRANSISTOR 2SC2785(H) or	QQSH02SC2785
	TRANSISTOR 2SC2785(J) or	QQSJ02SC2785
	TRANSISTOR KTC3199(GR) or	NQS10KTC3199
	TRANSISTOR KTC3198(GR) or	NQS40KTC3198
	TRANSISTOR 2SC3331(T)-AANP or	2SC3331TZ
	TRANSISTOR 2SC3331(U)-AANP or	2SC3331UZ
	TRANSISTOR 2SC1815-GR(TPE2)	QQS102SC1815
Q793	TRANSISTOR 2SA1175(F) or	QQSF02SA1175
	TRANSISTOR KTA1267(GR) or	NQS10KTA1267
	TRANSISTOR KTA1266(GR) or	NQS40KTA1266
	TRANSISTOR 2SA1318(T)-AANP or	2SA1318TZ
	TRANSISTOR 2SA1318(U)-AANP or	2SA1318UZ
	TRANSISTOR 2SA1015-GR(TPE2)	QQS102SA1015
Q794	RES. BUILT-IN TRANSISTOR BA1F4M-T or	QQSZ00BA1F4M
	RES. BUILT-IN TRANSISTOR KRC103M	NQSZ0KRC103M
Q825	TRANSISTOR 2SC2785(F) or	QQSF02SC2785
	TRANSISTOR 2SC2785(H) or	QQSH02SC2785
	TRANSISTOR 2SC2785(J) or	QQSJ02SC2785
	TRANSISTOR KTC3199(GR) or	NQS10KTC3199
	TRANSISTOR KTC3198(GR) or	NQS40KTC3198

Ref. No.	Description	Part No.
	TRANSISTOR 2SC3331(T)-AANP or	2SC3331TZ
	TRANSISTOR 2SC3331(U)-AANP or	2SC3331UZ
	TRANSISTOR 2SC1815-GR(TPE2)	QQS102SC1815
Q831 ▲	TRANSISTOR 2SB892(S) or	QQSS002SB892
▲	TRANSISTOR 2SB892(T)	QQST002SB892
Q832	TRANSISTOR 2SC2785(F) or	QQSF02SC2785
	TRANSISTOR 2SC2785(H) or	QQSH02SC2785
	TRANSISTOR 2SC2785(J) or	QQSJ02SC2785
	TRANSISTOR KTC3199(GR) or	NQS10KTC3199
	TRANSISTOR KTC3198(GR) or	NQS40KTC3198
	TRANSISTOR 2SC3331(T)-AANP or	2SC3331TZ
	TRANSISTOR 2SC3331(U)-AANP or	2SC3331UZ
	TRANSISTOR 2SC1815-GR(TPE2)	QQS102SC1815
Q841	TRANSISTOR 2SC2785(F) or	QQSF02SC2785
	TRANSISTOR 2SC2785(H) or	QQSH02SC2785
	TRANSISTOR 2SC2785(J) or	QQSJ02SC2785
	TRANSISTOR KTC3199(GR) or	NQS10KTC3199
	TRANSISTOR KTC3198(GR) or	NQS40KTC3198
	TRANSISTOR 2SC3331(T)-AANP or	2SC3331TZ
	TRANSISTOR 2SC3331(U)-AANP or	2SC3331UZ
	TRANSISTOR 2SC1815-GR(TPE2)	QQS102SC1815
Q851 ▲	TRANSISTOR 2SC2120-O-TPE2 or	QQS002SC2120
▲	TRANSISTOR 2SC2120-Y(TPE2) or	QQSY02SC2120
▲	TRANSISTOR KTC3203(Y)	NQSY0KTC3203
Q951	TRANSISTOR 2SA1175(F) or	QQSF02SA1175
	TRANSISTOR KTA1267(GR) or	NQS10KTA1267
	TRANSISTOR KTA1266(GR) or	NQS40KTA1266
	TRANSISTOR 2SA1318(T)-AANP or	2SA1318TZ
	TRANSISTOR 2SA1318(U)-AANP or	2SA1318UZ
	TRANSISTOR 2SA1015-GR(TPE2)	QQS102SA1015
Q956	TRANSISTOR 2SA1175(F) or	QQSF02SA1175
	TRANSISTOR KTA1267(GR) or	NQS10KTA1267
	TRANSISTOR KTA1266(GR) or	NQS40KTA1266
	TRANSISTOR 2SA1318(T)-AANP or	2SA1318TZ
	TRANSISTOR 2SA1318(U)-AANP or	2SA1318UZ
	TRANSISTOR 2SA1015-GR(TPE2)	QQS102SA1015
Q961 ▲	TRANSISTOR 2SC2120-O-TPE2 or	QQS002SC2120
▲	TRANSISTOR 2SC2120-Y(TPE2) or	QQSY02SC2120
▲	TRANSISTOR KTC3203(Y)	NQSY0KTC3203
<b>RESISTORS</b>		
R23	CARBON RES. 1/4W J 1k Ω or	RCX4JATZ0102
	CARBON RES. 1/6W J 1k Ω	RCX6JATZ0102
R31	CARBON RES. 1/4W J 22k Ω	RCX4JATZ0223
R33	CARBON RES. 1/4W J 270 Ω or	RCX4JATZ0271
	CARBON RES. 1/6W J 270 Ω	RCX6JATZ0271
R34	CARBON RES. 1/4W J 220 Ω or	RCX4JATZ0221
	CARBON RES. 1/6W J 220 Ω	RCX6JATZ0221
R36	CARBON RES. 1/4W J 10k Ω	RCX4JATZ0103
R37	CARBON RES. 1/4W J 220 Ω or	RCX4JATZ0221
	CARBON RES. 1/6W J 220 Ω	RCX6JATZ0221
R38	CARBON RES. 1/4W J 3.3k Ω	RCX4JATZ0332
R39	CARBON RES. 1/4W J 27k Ω	RCX4JATZ0273
R40	CARBON RES. 1/4W J 100k Ω	RCX4JATZ0104
R43	CARBON RES. 1/4W J 12k Ω	RCX4JATZ0123
R44	CARBON RES. 1/4W J 100 Ω or	RCX4JATZ0101
	CARBON RES. 1/6W J 100 Ω	RCX6JATZ0101
R51	CARBON RES. 1/4W J 220k Ω	RCX4JATZ0224
R52	CARBON RES. 1/4W J 220k Ω	RCX4JATZ0224
R54	CARBON RES. 1/4W J 22k Ω	RCX4JATZ0223
R102	CARBON RES. 1/4W J 1.5k Ω	RCX4JATZ0152

Ref. No.	Description	Part No.
R103	CARBON RES. 1/4W J 2.2k Ω	RCX4JATZ0222
R104	CARBON RES. 1/4W J 2.7k Ω	RCX4JATZ0272
R105	CARBON RES. 1/4W J 4.7k Ω	RCX4JATZ0472
R108	CARBON RES. 1/4W J 10k Ω	RCX4JATZ0103
R109	CARBON RES. 1/4W J 10k Ω	RCX4JATZ0103
R111	CARBON RES. 1/4W J 100 Ω or	RCX4JATZ0101
	CARBON RES. 1/6W J 100 Ω	RCX6JATZ0101
R112	CARBON RES. 1/4W J 10k Ω	RCX4JATZ0103
R113	CARBON RES. 1/4W J 470k Ω	RCX4JATZ0474
R114	CARBON RES. 1/4W J 1k Ω or	RCX4JATZ0102
	CARBON RES. 1/6W J 1k Ω	RCX6JATZ0102
R116	PCB JUMPER D0.6-P5.0	JW5.0T
R132	PCB JUMPER D0.6-P5.0	JW5.0T
R133	PCB JUMPER D0.6-P5.0	JW5.0T
R135	CARBON RES. 1/4W J 2.2k Ω	RCX4JATZ0222
R136	CARBON RES. 1/4W J 100k Ω	RCX4JATZ0104
R137	CARBON RES. 1/4W J 100 Ω or	RCX4JATZ0101
	CARBON RES. 1/6W J 100 Ω	RCX6JATZ0101
R138	CARBON RES. 1/4W J 220k Ω	RCX4JATZ0224
R139	CARBON RES. 1/4W J 22k Ω	RCX4JATZ0223
R140	CARBON RES. 1/4W J 1k Ω or	RCX4JATZ0102
	CARBON RES. 1/6W J 1k Ω	RCX6JATZ0102
R141	PCB JUMPER D0.6-P5.0	JW5.0T
R142	CARBON RES. 1/4W J 470 Ω or	RCX4JATZ0471
	CARBON RES. 1/6W J 470 Ω	RCX6JATZ0471
R150	PCB JUMPER D0.6-P5.0	JW5.0T
R153	CARBON RES. 1/4W J 100 Ω or	RCX4JATZ0101
	CARBON RES. 1/6W J 100 Ω	RCX6JATZ0101
R154	CARBON RES. 1/4W J 100 Ω or	RCX4JATZ0101
	CARBON RES. 1/6W J 100 Ω	RCX6JATZ0101
R156	CARBON RES. 1/4W J 100 Ω or	RCX4JATZ0101
	CARBON RES. 1/6W J 100 Ω	RCX6JATZ0101
R157	CARBON RES. 1/4W J 100 Ω or	RCX4JATZ0101
	CARBON RES. 1/6W J 100 Ω	RCX6JATZ0101
R158	CARBON RES. 1/4W J 1k Ω or	RCX4JATZ0102
	CARBON RES. 1/6W J 1k Ω	RCX6JATZ0102
R159	CARBON RES. 1/4W J 100 Ω or	RCX4JATZ0101
	CARBON RES. 1/6W J 100 Ω	RCX6JATZ0101
R161	CARBON RES. 1/4W J 470 Ω or	RCX4JATZ0471
	CARBON RES. 1/6W J 470 Ω	RCX6JATZ0471
R163	CARBON RES. 1/4W J 470 Ω or	RCX4JATZ0471
	CARBON RES. 1/6W J 470 Ω	RCX6JATZ0471
R164	CARBON RES. 1/4W J 10k Ω	RCX4JATZ0103
R165	CARBON RES. 1/4W J 4.7k Ω	RCX4JATZ0472
R166	CARBON RES. 1/4W J 6.8k Ω	RCX4JATZ0682
R167	CARBON RES. 1/4W J 22k Ω	RCX4JATZ0223
R168	CARBON RES. 1/4W J 4.7k Ω	RCX4JATZ0472
R170	CARBON RES. 1/4W J 5.6k Ω	RCX4JATZ0562
R171	CARBON RES. 1/4W J 3.9k Ω	RCX4JATZ0392
R172	PCB JUMPER D0.6-P5.0	JW5.0T
R173	CARBON RES. 1/4W J 22k Ω	RCX4JATZ0223
R174	CARBON RES. 1/4W J 10k Ω	RCX4JATZ0103
R176	CARBON RES. 1/4W J 100 Ω or	RCX4JATZ0101
	CARBON RES. 1/6W J 100 Ω	RCX6JATZ0101
R177	CARBON RES. 1/4W J 100 Ω or	RCX4JATZ0101
	CARBON RES. 1/6W J 100 Ω	RCX6JATZ0101
R178	CARBON RES. 1/4W J 470 Ω or	RCX4JATZ0471
	CARBON RES. 1/6W J 470 Ω	RCX6JATZ0471
R193	CARBON RES. 1/4W J 22k Ω	RCX4JATZ0223
R195	CARBON RES. 1/4W J 2.2k Ω	RCX4JATZ0222
R196	CARBON RES. 1/4W J 100 Ω or	RCX4JATZ0101

Ref. No.	Description	Part No.
	CARBON RES. 1/6W J 100 Ω	RCX6JATZ0101
R198	PCB JUMPER D0.6-P5.0	JW5.0T
R301	CARBON RES. 1/4W J 6.8k Ω	RCX4JATZ0682
R302	CARBON RES. 1/4W J 100 Ω or	RCX4JATZ0101
	CARBON RES. 1/6W J 100 Ω	RCX6JATZ0101
R303	CARBON RES. 1/4W J 470 Ω or	RCX4JATZ0471
	CARBON RES. 1/6W J 470 Ω	RCX6JATZ0471
R305	CARBON RES. 1/4W J 470 Ω or	RCX4JATZ0471
	CARBON RES. 1/6W J 470 Ω	RCX6JATZ0471
R320	CARBON RES. 1/4W J 10k Ω	RCX4JATZ0103
R323	CARBON RES. 1/4W J 2.2k Ω	RCX4JATZ0222
R326	CARBON RES. 1/4W J 100 Ω or	RCX4JATZ0101
	CARBON RES. 1/6W J 100 Ω	RCX6JATZ0101
R327	PCB JUMPER D0.6-P5.0	JW5.0T
R328	CARBON RES. 1/4W J 3.3k Ω	RCX4JATZ0332
R329	CARBON RES. 1/4W J 56k Ω	RCX4JATZ0563
R330	CARBON RES. 1/4W J 1k Ω or	RCX4JATZ0102
	CARBON RES. 1/6W J 1k Ω	RCX6JATZ0102
R333	CARBON RES. 1/4W J 330 Ω or	RCX4JATZ0331
	CARBON RES. 1/6W J 330 Ω	RCX6JATZ0331
R342	PCB JUMPER D0.6-P5.0	JW5.0T
R344	CARBON RES. 1/4W J 6.8k Ω	RCX4JATZ0682
R345	CARBON RES. 1/4W J 10k Ω	RCX4JATZ0103
R346	CARBON RES. 1/4W J 1k Ω or	RCX4JATZ0102
	CARBON RES. 1/6W J 1k Ω	RCX6JATZ0102
R347	PCB JUMPER D0.6-P5.0	JW5.0T
R348	CARBON RES. 1/4W J 27k Ω	RCX4JATZ0273
R355	CARBON RES. 1/4W J 15k Ω	RCX4JATZ0153
R356	CARBON RES. 1/4W J 100 Ω or	RCX4JATZ0101
	CARBON RES. 1/6W J 100 Ω	RCX6JATZ0101
R357	CARBON RES. 1/4W J 100 Ω or	RCX4JATZ0101
	CARBON RES. 1/6W J 100 Ω	RCX6JATZ0101
R358	CARBON RES. 1/4W J 100 Ω or	RCX4JATZ0101
	CARBON RES. 1/6W J 100 Ω	RCX6JATZ0101
R362	PCB JUMPER D0.6-P5.0	JW5.0T
R417	CARBON RES. 1/4W J 180k Ω	RCX4JATZ0184
R422	CARBON RES. 1/4W J 2.2k Ω	RCX4JATZ0222
R427	CARBON RES. 1/4W J 2.2k Ω	RCX4JATZ0222
R445	CARBON RES. 1/4W J 3.3k Ω	RCX4JATZ0332
R503	CARBON RES. 1/4W J 68k Ω	RCX4JATZ0683
R504	CARBON RES. 1/4W J 3.3 Ω or	RCX4JATZ03R3
	CARBON RES. 1/6W J 3.3 Ω	RCX6JATZ03R3
R505	CARBON RES. 1/4W J 1.8k Ω	RCX4JATZ0182
R506	CARBON RES. 1/4W J 2.7 Ω or	RCX4JATZ02R7
	CARBON RES. 1/6W J 2.7 Ω	RCX6JATZ02R7
R507	CARBON RES. 1/4W J 2.7 Ω or	RCX4JATZ02R7
	CARBON RES. 1/6W J 2.7 Ω	RCX6JATZ02R7
R508	CARBON RES. 1/4W J 2.7 Ω or	RCX4JATZ02R7
	CARBON RES. 1/6W J 2.7 Ω	RCX6JATZ02R7
R513▲	METAL OXIDE FILM RES. 2W J 4.7 Ω or	RN024R7ZU001
▲	METAL OXIDE FILM RES. 2W J 4.7 Ω	RN024R7DP004
R514	CARBON RES. 1/4W J 2.7k Ω	RCX4JATZ0272
R516	CARBON RES. 1/4W J 680 Ω or	RCX4JATZ0681
	CARBON RES. 1/6W J 680 Ω	RCX6JATZ0681
R520▲	CARBON RES. 1/4W J 22k Ω	RCX4JATZ0223
R522	CARBON RES. 1/4W J 22k Ω	RCX4JATZ0223
R531	CARBON RES. 1/4W J 1.8k Ω	RCX4JATZ0182
R532	CARBON RES. 1/4W J 22k Ω	RCX4JATZ0223
R533	CARBON RES. 1/4W J 22k Ω	RCX4JATZ0223
R534	CARBON RES. 1/4W J 22k Ω	RCX4JATZ0223
R535	CARBON RES. 1/4W J 470 Ω or	RCX4JATZ0471

Ref. No.	Description	Part No.
	CARBON RES. 1/6W J 470 Ω	RCX6JATZ0471
R541	CARBON RES. 1/4W J 680 Ω or	RCX4JATZ0681
	CARBON RES. 1/6W J 680 Ω	RCX6JATZ0681
R542	CARBON RES. 1/4W J 680 Ω or	RCX4JATZ0681
	CARBON RES. 1/6W J 680 Ω	RCX6JATZ0681
R543	CARBON RES. 1/4W J 680 Ω or	RCX4JATZ0681
	CARBON RES. 1/6W J 680 Ω	RCX6JATZ0681
R545	CARBON RES. 1/4W J 6.8k Ω	RCX4JATZ0682
R546	CARBON RES. 1/4W J 2.2k Ω	RCX4JATZ0222
R547	CARBON RES. 1/4W J 2.7k Ω	RCX4JATZ0272
R548	CARBON RES. 1/4W J 10k Ω	RCX4JATZ0103
R549	CARBON RES. 1/4W J 1.5k Ω	RCX4JATZ0152
R551▲	METAL OXIDE FILM RES. 1W J 1k Ω or	RN01102ZU001
▲	METAL OXIDE FILM RES. 1W J 1k Ω	RN01102DP003
R552▲	METAL OXIDE FILM RES. 1W J 8.2 Ω or	RN018R2ZU001
▲	METAL OXIDE FILM RES. 1W J 8.2 Ω	RN018R2DP003
R553	CARBON RES. 1/4W J 2.2k Ω	RCX4JATZ0222
R554	CARBON RES. 1/4W J 3.3k Ω	RCX4JATZ0332
R555▲	CARBON RES. 1/4W J 1.5k Ω	RCX4JATZ0152
R556	CARBON RES. 1/4W J 100k Ω	RCX4JATZ0104
R557	CARBON RES. 1/4W J 18k Ω	RCX4JATZ0183
R558	CARBON RES. 1/4W J 220 Ω or	RCX4JATZ0221
	CARBON RES. 1/6W J 220 Ω	RCX6JATZ0221
R559	CARBON RES. 1/4W J 47k Ω	RCX4JATZ0473
R560	CARBON RES. 1/4W J 150k Ω	RCX4JATZ0154
R561	CARBON RES. 1/4W J 1.2k Ω	RCX4JATZ0122
R562	CARBON RES. 1/4W J 100k Ω	RCX4JATZ0104
R563	CARBON RES. 1/4W J 10k Ω	RCX4JATZ0103
R564	CARBON RES. 1/4W J 270k Ω	RCX4JATZ0274
R565	CARBON RES. 1/4W J 33k Ω	RCX4JATZ0333
R566	CARBON RES. 1/4W J 10k Ω	RCX4JATZ0103
R567	CARBON RES. 1/4W J 47k Ω	RCX4JATZ0473
R568	CARBON RES. 1/4W J 1k Ω or	RCX4JATZ0102
	CARBON RES. 1/6W J 1k Ω	RCX6JATZ0102
R569	CARBON RES. 1/4W J 560k Ω	RCX4JATZ0564
R575▲	CARBON RES. 1/4W J 15 Ω or	RCX4JATZ0150
▲	CARBON RES. 1/6W J 15 Ω	RCX6JATZ0150
R576	CARBON RES. 1/4W J 1k Ω or	RCX4JATZ0102
	CARBON RES. 1/6W J 1k Ω	RCX6JATZ0102
R577	CARBON RES. 1/4W J 330 Ω or	RCX4JATZ0331
	CARBON RES. 1/6W J 330 Ω	RCX6JATZ0331
R578	CARBON RES. 1/4W J 15 Ω or	RCX4JATZ0150
	CARBON RES. 1/6W J 15 Ω	RCX6JATZ0150
R579	CARBON RES. 1/4W J 15 Ω or	RCX4JATZ0150
	CARBON RES. 1/6W J 15 Ω	RCX6JATZ0150
R581	PCB JUMPER D0.6-P5.0	JW5.0T
R583▲	METAL OXIDE FILM RES. 2W J 1.5 Ω or	RN021R5ZU001
▲	METAL OXIDE FILM RES. 2W J 1.5 Ω	RN021R5DP004
R584▲	PCB JUMPER D0.6-P5.0	JW5.0T
R585▲	CARBON RES. 1/4W J 10k Ω	RCX4JATZ0103
R586▲	CARBON RES. 1/4W J 470k Ω	RCX4JATZ0474
R587	CARBON RES. 1/4W J 470k Ω	RCX4JATZ0474
R588	CARBON RES. 1/4W J 47k Ω	RCX4JATZ0473
R589▲	CARBON RES. 1/4W J 47k Ω	RCX4JATZ0473
R590	CARBON RES. 1/4W J 22k Ω	RCX4JATZ0223
R591▲	CARBON RES. 1/4W J 180k Ω	RCX4JATZ0184
R592▲	CARBON RES. 1/4W J 220k Ω	RCX4JATZ0224
R593▲	CARBON RES. 1/4W J 68k Ω	RCX4JATZ0683
R594▲	CARBON RES. 1/4W J 100k Ω	RCX4JATZ0104
R596	CARBON RES. 1/4W J 100k Ω	RCX4JATZ0104
R597	CARBON RES. 1/4W J 8.2k Ω	RCX4JATZ0822

Ref. No.	Description	Part No.
R598▲	CARBON RES. 1/4W J 33k Ω	RCX4JATZ0333
R599▲	CARBON RES. 1/4W J 15k Ω	RCX4JATZ0153
R601▲	CEMENT RES. 7W K 0.56 Ω or	RW07R56DP007
▲	CEMENT RESISTOR 7W K 0.56 Ω H=10MM	RW07R56PG001
R602	CARBON RES. 1/4W J 820k Ω	RCX4JATZ0824
R603	CARBON RES. 1/4W J 820k Ω	RCX4JATZ0824
R604	CARBON RES. 1/4W J 820k Ω	RCX4JATZ0824
R605	CARBON RES. 1/4W J 820k Ω	RCX4JATZ0824
R607	CARBON RES. 1/4W J 220 Ω or	RCX4JATZ0221
	CARBON RES. 1/6W J 220 Ω	RCX6JATZ0221
R608	CARBON RES. 1/4W J 220 Ω or	RCX4JATZ0221
	CARBON RES. 1/6W J 220 Ω	RCX6JATZ0221
R609	CARBON RES. 1/4W J 820k Ω	RCX4JATZ0824
R613▲	CEMENT RES. 5W K 0.27 Ω or	RW05R27DP005
▲	CEMENT RESISTOR 5W K 0.27 Ω	RW05R27PG001
R616	CARBON RES. 1/4W J 10k Ω	RCX4JATZ0103
R618	CARBON RES. 1/4W J 390 Ω or	RCX4JATZ0391
	CARBON RES. 1/6W J 390 Ω	RCX6JATZ0391
R620▲	CARBON RES. 1/4W J 100 Ω or	RCX4JATZ0101
▲	CARBON RES. 1/6W J 100 Ω	RCX6JATZ0101
R621	CARBON RES. 1/4W J 1.5k Ω	RCX4JATZ0152
R622	CARBON RES. 1/4W J 47 Ω or	RCX4JATZ0470
	CARBON RES. 1/6W J 47 Ω	RCX6JATZ0470
R623	CARBON RES. 1/4W J 39 Ω or	RCX4JATZ0390
	CARBON RES. 1/6W J 39 Ω	RCX6JATZ0390
R651▲	METAL OXIDE FILM RES. 2W J 15k Ω or	RN02153ZU001
▲	METAL OXIDE FILM RES. 2W J 15k Ω	RN02153DP004
R652	CARBON RES. 1/4W J 15k Ω	RCX4JATZ0153
R653	CARBON RES. 1/4W J 22k Ω	RCX4JATZ0223
R654▲	CARBON RES. 1/4W J 2.7k Ω	RCX4JATZ0272
R655	CARBON RES. 1/4W J 1k Ω or	RCX4JATZ0102
	CARBON RES. 1/6W J 1k Ω	RCX6JATZ0102
R656▲	CARBON RES. 1/4W J 15k Ω	RCX4JATZ0153
R657	CARBON RES. 1/4W J 15k Ω	RCX4JATZ0153
R658	CARBON RES. 1/4W J 470k Ω	RCX4JATZ0474
R660	CARBON RES. 1/4W J 1k Ω or	RCX4JATZ0102
	CARBON RES. 1/6W J 1k Ω	RCX6JATZ0102
R661▲	CARBON RES. 1/4W J 100k Ω	RCX4JATZ0104
R662▲	CARBON RES. 1/4W J 82k Ω	RCX4JATZ0823
R663▲	PCB JUMPER D0.6-P5.0	JW5.0T
R664▲	CARBON RES. 1/4W J 12k Ω	RCX4JATZ0123
R665▲	CARBON RES. 1/4W J 5.6k Ω	RCX4JATZ0562
R666▲	METAL OXIDE FILM RES. 1W J 100k Ω or	RN01104ZU001
▲	METAL OXIDE FILM RES. 1W J 100k Ω	RN01104DP003
R667▲	CARBON RES. 1/4W J 33k Ω	RCX4JATZ0333
R668▲	CARBON RES. 1/4W J 33k Ω	RCX4JATZ0333
R669▲	CARBON RES. 1/4W J 33k Ω	RCX4JATZ0333
R670▲	CARBON RES. 1/4W J 100k Ω	RCX4JATZ0104
R671▲	CARBON RES. 1/4W J 3.3k Ω	RCX4JATZ0332
R672▲	CARBON RES. 1/4W J 3.3k Ω	RCX4JATZ0332
R673▲	CARBON RES. 1/4W J 100k Ω	RCX4JATZ0104
R674	CARBON RES. 1/4W J 22k Ω	RCX4JATZ0223
R676	CARBON RES. 1/4W J 10k Ω	RCX4JATZ0103
R677	CARBON RES. 1/4W J 15k Ω	RCX4JATZ0153
R678	CARBON RES. 1/4W J 47k Ω	RCX4JATZ0473
R679▲	CARBON RES. 1/4W J 3.3k Ω	RCX4JATZ0332
R680	CARBON RES. 1/4W J 10k Ω	RCX4JATZ0103
R681▲	CARBON RES. 1/4W J 12 Ω or	RCX4JATZ0120
▲	CARBON RES. 1/6W J 12 Ω	RCX6JATZ0120
R682▲	METAL OXIDE FILM RES. 2W J 33 Ω or	RN02330ZU001
▲	METAL OXIDE FILM RES. 2W J 33 Ω	RN02330DP004

Ref. No.	Description	Part No.
R683▲	METAL RESISTOR 2W J 39 Ω or	RN02390ZU001
▲	METAL OXIDE FILM RES. 2W J 39 Ω	RN02390DP004
R686	CARBON RES. 1/4W J 100 Ω or	RCX4JATZ0101
	CARBON RES. 1/6W J 100 Ω	RCX6JATZ0101
R687	CARBON RES. 1/4W J 10 Ω or	RCX4JATZ0100
	CARBON RES. 1/6W J 10 Ω	RCX6JATZ0100
R694▲	CARBON RES. 1/4W J 4.7k Ω	RCX4JATZ0472
R696▲	CARBON RES. 1/4W J 10 Ω or	RCX4JATZ0100
▲	CARBON RES. 1/6W J 10 Ω	RCX6JATZ0100
R697	PCB JUMPER D0.6-P5.0	JW5.0T
R701	CARBON RES. 1/4W J 82 Ω or	RCX4JATZ0820
	CARBON RES. 1/6W J 82 Ω	RCX6JATZ0820
R702	CARBON RES. 1/4W J 82 Ω or	RCX4JATZ0820
	CARBON RES. 1/6W J 82 Ω	RCX6JATZ0820
R704	CARBON RES. 1/4W J 47k Ω	RCX4JATZ0473
R705	CARBON RES. 1/4W J 2.2k Ω	RCX4JATZ0222
R706	CARBON RES. 1/4W J 33k Ω	RCX4JATZ0333
R707	CARBON RES. 1/4W J 47k Ω	RCX4JATZ0473
R708	CARBON RES. 1/4W J 2.2k Ω	RCX4JATZ0222
R709	CARBON RES. 1/4W J 33k Ω	RCX4JATZ0333
R711	CARBON RES. 1/4W J 82 Ω or	RCX4JATZ0820
	CARBON RES. 1/6W J 82 Ω	RCX6JATZ0820
R713	CARBON RES. 1/4W J 330 Ω or	RCX4JATZ0331
	CARBON RES. 1/6W J 330 Ω	RCX6JATZ0331
R716	CARBON RES. 1/4W J 82 Ω or	RCX4JATZ0820
	CARBON RES. 1/6W J 82 Ω	RCX6JATZ0820
R718	CARBON RES. 1/4W J 330 Ω or	RCX4JATZ0331
	CARBON RES. 1/6W J 330 Ω	RCX6JATZ0331
R721	CARBON RES. 1/4W J 82 Ω or	RCX4JATZ0820
	CARBON RES. 1/6W J 82 Ω	RCX6JATZ0820
R722	CARBON RES. 1/4W J 82 Ω or	RCX4JATZ0820
	CARBON RES. 1/6W J 82 Ω	RCX6JATZ0820
R724	CARBON RES. 1/4W J 47k Ω	RCX4JATZ0473
R725	CARBON RES. 1/4W J 2.2k Ω	RCX4JATZ0222
R726	CARBON RES. 1/4W J 33k Ω	RCX4JATZ0333
R727	CARBON RES. 1/4W J 47k Ω	RCX4JATZ0473
R728	CARBON RES. 1/4W J 2.2k Ω	RCX4JATZ0222
R729	CARBON RES. 1/4W J 33k Ω	RCX4JATZ0333
R751	CARBON RES. 1/4W J 22k Ω	RCX4JATZ0223
R752	CARBON RES. 1/4W J 27k Ω	RCX4JATZ0273
R753	CARBON RES. 1/4W J 56k Ω	RCX4JATZ0563
R754	CARBON RES. 1/4W J 18k Ω	RCX4JATZ0183
R755	CARBON RES. 1/4W J 1.8k Ω	RCX4JATZ0182
R756	CARBON RES. 1/4W J 1k Ω or	RCX4JATZ0102
	CARBON RES. 1/6W J 1k Ω	RCX6JATZ0102
R757	CARBON RES. 1/4W J 560 Ω or	RCX4JATZ0561
	CARBON RES. 1/6W J 560 Ω	RCX6JATZ0561
R761	CARBON RES. 1/4W J 22k Ω	RCX4JATZ0223
R762	CARBON RES. 1/4W J 27k Ω	RCX4JATZ0273
R763	CARBON RES. 1/4W J 56k Ω	RCX4JATZ0563
R764	CARBON RES. 1/4W J 18k Ω	RCX4JATZ0183
R765	CARBON RES. 1/4W J 1.8k Ω	RCX4JATZ0182
R766	CARBON RES. 1/4W J 1k Ω or	RCX4JATZ0102
	CARBON RES. 1/6W J 1k Ω	RCX6JATZ0102
R767	CARBON RES. 1/4W J 560 Ω or	RCX4JATZ0561
	CARBON RES. 1/6W J 560 Ω	RCX6JATZ0561
R771	CARBON RES. 1/4W J 4.7k Ω	RCX4JATZ0472
R772	CARBON RES. 1/4W J 10k Ω	RCX4JATZ0103
R791	CARBON RES. 1/4W J 4.7k Ω	RCX4JATZ0472
R792	CARBON RES. 1/4W J 4.7k Ω	RCX4JATZ0472
R793	CARBON RES. 1/4W J 10k Ω	RCX4JATZ0103

Ref. No.	Description	Part No.
R803	CARBON RES. 1/4W J 100 Ω or	RCX4JATZ0101
	CARBON RES. 1/6W J 100 Ω	RCX6JATZ0101
R804	CARBON RES. 1/4W J 100 Ω or	RCX4JATZ0101
	CARBON RES. 1/6W J 100 Ω	RCX6JATZ0101
R811	CARBON RES. 1/4W J 18k Ω	RCX4JATZ0183
R812	CARBON RES. 1/4W J 18k Ω	RCX4JATZ0183
R817	CARBON RES. 1/4W J 5.6k Ω	RCX4JATZ0562
R818	CARBON RES. 1/4W J 33k Ω	RCX4JATZ0333
R827	CARBON RES. 1/4W J 1k Ω or	RCX4JATZ0102
	CARBON RES. 1/6W J 1k Ω	RCX6JATZ0102
R828	CARBON RES. 1/4W J 10k Ω	RCX4JATZ0103
R829	CARBON RES. 1/4W J 10k Ω	RCX4JATZ0103
R831	CARBON RES. 1/4W J 470 Ω or	RCX4JATZ0471
	CARBON RES. 1/6W J 470 Ω	RCX6JATZ0471
R832	CARBON RES. 1/4W J 22k Ω	RCX4JATZ0223
R833	CARBON RES. 1/4W J 470 Ω or	RCX4JATZ0471
	CARBON RES. 1/6W J 470 Ω	RCX6JATZ0471
R834	CARBON RES. 1/4W J 4.7k Ω	RCX4JATZ0472
R841	METAL OXIDE FILM RES. 2W J 0.47 Ω or	RN02R47ZU001
	METAL OXIDE FILM RES. 2W J 0.47 Ω	RN02R47DP004
R842	CARBON RES. 1/4W J 560 Ω or	RCX4JATZ0561
	CARBON RES. 1/6W J 560 Ω	RCX6JATZ0561
R843	CARBON RES. 1/4W J 2.2k Ω	RCX4JATZ0222
R844	CARBON RES. 1/4W J 100 Ω or	RCX4JATZ0101
	CARBON RES. 1/6W J 100 Ω	RCX6JATZ0101
R845	CARBON RES. 1/4W J 22k Ω	RCX4JATZ0223
R851▲	CARBON RES. 1/4W J 330 Ω or	RCX4JATZ0331
▲	CARBON RES. 1/6W J 330 Ω	RCX6JATZ0331
R855▲	CARBON RES. 1/4W J 2.2k Ω	RCX4JATZ0222
R856▲	CARBON RES. 1/4W J 2.2k Ω	RCX4JATZ0222
R951	CARBON RES. 1/4W J 220 Ω or	RCX4JATZ0221
	CARBON RES. 1/6W J 220 Ω	RCX6JATZ0221
R952	CARBON RES. 1/4W J 10k Ω	RCX4JATZ0103
R953	CARBON RES. 1/4W J 47 Ω or	RCX4JATZ0470
	CARBON RES. 1/6W J 47 Ω	RCX6JATZ0470
R954	CARBON RES. 1/4W J 75 Ω or	RCX4JATZ0750
	CARBON RES. 1/6W J 75 Ω	RCX6JATZ0750
R956	CARBON RES. 1/4W J 220 Ω or	RCX4JATZ0221
	CARBON RES. 1/6W J 220 Ω	RCX6JATZ0221
R957	CARBON RES. 1/4W J 10k Ω	RCX4JATZ0103
R959	CARBON RES. 1/4W J 75 Ω or	RCX4JATZ0750
	CARBON RES. 1/6W J 75 Ω	RCX6JATZ0750
R961	PCB JUMPER D0.6-P5.0	JW5.0T
R962	CARBON RES. 1/4W J 470 Ω or	RCX4JATZ0471
	CARBON RES. 1/6W J 470 Ω	RCX6JATZ0471
R966▲	CARBON RES. 1/4W J 2.2k Ω	RCX4JATZ0222
R967▲	CARBON RES. 1/4W J 10k Ω	RCX4JATZ0103
<b>SWITCHES</b>		
SW101	TACT SWITCH SKQSAB or	SST0101AL038
	TACT SWITCH KSM0612B or	SST0101HH003
	TACT SWITCH SKHHAM	SST0101AL029
SW102	TACT SWITCH SKQSAB or	SST0101AL038
	TACT SWITCH KSM0612B or	SST0101HH003
	TACT SWITCH SKHHAM	SST0101AL029
SW103	TACT SWITCH SKQSAB or	SST0101AL038
	TACT SWITCH KSM0612B or	SST0101HH003
	TACT SWITCH SKHHAM	SST0101AL029
SW104	TACT SWITCH SKQSAB or	SST0101AL038
	TACT SWITCH KSM0612B or	SST0101HH003
	TACT SWITCH SKHHAM	SST0101AL029

Ref. No.	Description	Part No.
SW105	TACT SWITCH SKQSAB or	SST0101AL038
	TACT SWITCH KSM0612B or	SST0101HH003
	TACT SWITCH SKHHAM	SST0101AL029
SW106	TACT SWITCH SKQSAB or	SST0101AL038
	TACT SWITCH KSM0612B or	SST0101HH003
	TACT SWITCH SKHHAM	SST0101AL029
<b>MISCELLANEOUS</b>		
AC601▲	AC CORD LA-2413	WAC0172LW007
B-6	HEAT SINK(PGM)ASSEMBLY L6250UA	0EM407156
B-7	HEAT SINK(PFN)ASSEMBLY L1520UZ	0EM406353
B-8	HEAT SINK(PGN)ASSEMBLY L6250UA	0EM407158
B-9	HEAT SINK(PGO) L6250UA	0EM407159
BC571	BEAD INDUCTORS FBA04HA600VB-00	LLBF00STU026
BC572	BEAD INDUCTORS FBA04HA600VB-00	LLBF00STU026
BC602	PCB JUMPER D0.6-P5.0	JW5.0T
BC603	BEAD INDUCTORS FBR07HA121TB-00	LLBF00ZTU021
BC652	BEAD INDUCTORS FBR07HA121TB-00	LLBF00ZTU021
BC653	PCB JUMPER D0.6-P5.0	JW5.0T
BC654	BEAD INDUCTORS FBR07HA121TB-00	LLBF00ZTU021
BC655	BEAD INDUCTORS FBR07HA121TB-00	LLBF00ZTU021
BC656	BEAD INDUCTORS FBR07HA121TB-00	LLBF00ZTU021
BC657	BEAD INDUCTORS FBR07HA121TB-00	LLBF00ZTU021
BC691	BEAD INDUCTORS FBR07HA121TB-00	LLBF00ZTU021
BC692	BEAD INDUCTORS FBR07HA121TB-00	LLBF00ZTU021
CF31	CERAMIC TRAP 4.5MHz or	FBE455PMR003
	CERAMIC TRAP 4.5MHz	FBE455PMS001
CF32	CERAMIC FILTER SFSRA4M50CF00-B0 or	FBB455PMR004
	CERAMIC FILTER 4.5MHz	FBB455PMS001
CLN1	LEAD WIRE UL1007 AWG22 BLACK 140MM	WX3001A2FF14
CLN301	WIRE ASSEMBLY WX1L1520-103	WX1L1520-103
CLN501	WIRE ASSEMBLY WX1L1520-101	WX1L1520-101
F601▲	FUSE 4A/125V 237 TYPE or	PAGJ20CAG402
▲	FUSE TDS4A125VU/C or	PAGD20CW3402
▲	FUSE STC4A125V U/CT or	PAGE20CW3402
▲	FUSE 4.00A/125V	PAGG20CNG402
FH601	FUSE HOLDER MSF-015 or	XH01Z00LY001
	FUSE HOLDER FH-V-03078 or	XH01Z00DK001
	HOLDER, FUSE CNT41-0014	1790424
FH602	FUSE HOLDER MSF-015 or	XH01Z00LY001
	FUSE HOLDER FH-V-03078 or	XH01Z00DK001
	HOLDER, FUSE CNT41-0014	1790424
GP641▲	GAP. FNR-G3.10D	FAZ000LD6005
JK701	RCA JACK(YELLOW) MSP-281V4-B	JXRL010LY003
JK702	RCA JACK 2P MSP-282V13 PBSN	JXRL020LY045
JK703	RCA JACK 2P(SW) MSP-292V07 PBSN	JYRL020LY011
JK711	Y/C JACK 1P(SW) MDC-070V1-A	JYEL040LY002
JK721	RCA JACK(YELLOW) MTJ-032-06B-20 or	JXRL010LY050
	RCA JACK 1P AV-8.4-9Y	JXRL010RP010
JK722	RCA JACK(WHITE) MTJ-032-06B-22 or	JXRL010LY052
	RCA JACK 1P AV-8.4-9W	JXRL010RP011
JK723	RCA JACK(RED) MTJ-032-06A-21 or	JYRL010LY014
	RCA JACK 1P(RED)WITH SW ITCH AV1-09S-2	JYRL010RP008
JS102	PCB JUMPER D0.6-P5.0	JW5.0T
JS104	PCB JUMPER D0.6-P5.0	JW5.0T
JS105	PCB JUMPER D0.6-P5.0	JW5.0T
JS171	PCB JUMPER D0.6-P15.0	JW15.0T
JS191	PCB JUMPER D0.6-P5.0	JW5.0T
JS301	PCB JUMPER D0.6-P5.0	JW5.0T
JS570	PCB JUMPER D0.6-P5.0	JW5.0T
JS642	PCB JUMPER D0.6-P10.0	JW10.0T

Ref. No.	Description	Part No.
JS801	PCB JUMPER D0.6-P5.0	JW5.0T
JS802	PCB JUMPER D0.6-P10.0	JW10.0T
JS821	PCB JUMPER D0.6-P5.0	JW5.0T
JS822	PCB JUMPER D0.6-P7.5	JW7.5T
L-1	SCREW, B-TIGHT M3X8 BIND HEAD+	GBMB3080
PB6	CLOTH(65) L7735TR.65X10X0.5T	0EM402149
PS691▲	THERMISTOR ZPB58BL7R0F	QNQZ58BL7R0F
RCV101	REMOCON RECEIVE UNIT MIM-93M8DKL or	USESJRSUNT02
	REMOCON RECEIVE UNIT PIC-37042SR or	USESJRSKK034
	REMOCON RECEIVE UNIT PIC-26042SR-2	USESJRSKK032
RL601▲	POWER RELAY SDT-S-112LMR	MRNDC12QN014
▲	POWER RELAY RPEF-12-901 or	MRNDC12KB002
▲	RELAY GD12D1-Q(M)-II or	MRNDC12DEC02
▲	RELAY ALKS321	MRNDC12MS013
SA601▲	SURGE ABSORBER AVR-S07D471KAAS or	QVQZ0AVRS07D
▲	SURGE ABSORBER JVR-07N471K or	NVQZVR07N471
▲	SURGE ABSORBER CNR-10D471K or	NVQZR10D471K
▲	SURGE ABSORBER CNR-07D471K or	NVQZ07D471K
▲	SURGE ABSORBER PVR-07D471KB	NVQZ07D471KB
SF1	SAW FILTER SAFGM45M7VHHzCOB03	FBB456PMR008
T571▲	FLYBACK TRANS BSC28-0731 or	LTF00CPP1019
▲	FLYBACK TRANSFORMER JF0501-2189	LTF00CPXB038
T572	HORIZONTAL DRAIVE TRANS Y2004 or	LTH00CPY2004
	HORIZONTAL DRAIVE TRANS CSA-LF044	LTH00CPSA002
T601▲	SWITCHING TRANS KD-L12-32V	LTT00CPKT095
TH556	PCB JUMPER D0.6-P5.0	JW5.0T
TP300	PCB JUMPER D0.6-P10.0	JW10.0T
TP301	PCB JUMPER D0.6-P7.5	JW7.5T
TP302	PCB JUMPER D0.6-P7.5	JW7.5T
TP500	PCB JUMPER D0.6-P7.5	JW7.5T
TP501	PCB JUMPER D0.6-P7.5	JW7.5T
TP591	PCB JUMPER D0.6-P5.0	JW5.0T
TP592	PCB JUMPER D0.6-P5.0	JW5.0T
TP601	PCB JUMPER D0.6-P7.5	JW7.5T
TU1	TUNER UNIT TEQH9-001A	UTUNNTUAL032
VR561	CARBON P.O.T. 20k Ω B or	VRCB203KA011
	CARBON P.O.T. 20k Ω B	VRCB203HH014
VR562	CARBON P.O.T. 5k Ω B or	VRCB502KA011
	CARBON P.O.T. 5k Ω B	VRCB502HH014
VR661▲	CARBON P.O.T. 50k Ω B or	VRCB503KA011
▲	CARBON P.O.T. 50k Ω B	VRCB503HH014
X301	XTAL 3.579545 MHz	FXD355LLN003

## CRT CBA

Ref. No.	Description	Part No.
	CRT CBA Consists of the following	-----
<b>CAPACITORS</b>		
C1501	ELECTROLYTIC CAP. 100μF/10V M or	CE1AMASTL101
	ELECTROLYTIC CAP. 100μF/10V M	CE1AMASDL101
C1502	ELECTROLYTIC CAP. 10μF/50V M or	CE1JMASL100
	ELECTROLYTIC CAP. 10μF/50V M	CE1JMASDL100
C1510	CERAMIC CAP. B K 2200pF/2KV or	CCD3DKD0B222
	CERAMIC CAP. B K 2200pF/2KV or	CCD3DKP0B222
	CERAMIC CAP. B K 2200pF/2KV	CA3D222MR030
C1511	CERAMIC CAP.(AX) B K 470pF/50V	CCA1JKT0B471
C1512	CERAMIC CAP.(AX) B K 0.01μF/50V	CA1J103TU011
C1521	CERAMIC CAP.(AX) B K 220pF/50V	CCA1JKT0B221
C1522	CERAMIC CAP.(AX) B K 0.01μF/50V	CA1J103TU011

Ref. No.	Description	Part No.
C1531	CERAMIC CAP.(AX) B K 470pF/50V	CCA1JKT0B471
C1532	CERAMIC CAP.(AX) B K 0.01µF/50V	CA1J103TU011
<b>CONNECTORS</b>		
CN1501	PIN CONNECTOR 005P-5100	JTEA001TG001
<b>DIODES</b>		
D1501	SWITCHING DIODE 1SS133(T-77) or	QDTZ001SS133
	SWITCHING DIODE 1N4148 or	NDTZ001N4148
	DIODE 1SS176TPA7	1SS176T
<b>COILS</b>		
L1501▲	INDUCTOR 150µH-J-5FT or	LLARJCSJU151
▲	INDUCTOR 150µH-K	LLARKDQKA151
L1511	PCB JUMPER D0.6-P5.0	JW5.0T
L1521	PCB JUMPER D0.6-P5.0	JW5.0T
L1531	PCB JUMPER D0.6-P5.0	JW5.0T
<b>TRANSISTORS</b>		
Q1511	TRANSISTOR 2SC2785(F) or	QQSF02SC2785
	TRANSISTOR 2SC2785(H) or	QQSH02SC2785
	TRANSISTOR 2SC2785(J) or	QQSJ02SC2785
	TRANSISTOR KTC3199(GR) or	NQS10KTC3199
	TRANSISTOR KTC3198(GR) or	NQS40KTC3198
	TRANSISTOR 2SC3331(T)-AANP or	2SC3331TZ
	TRANSISTOR 2SC3331(U)-AANP or	2SC3331UZ
	TRANSISTOR 2SC1815-GR(TPE2)	QQS102SC1815
Q1512	TRANSISTOR 2SC5360 or	QQ9Z02SC5360
	TRANSISTOR 2SC4544 or	QQ9Z02SC4544
	TRANSISTOR KTC3229	NQ5Z0KTC3229
Q1521	TRANSISTOR 2SC2785(F) or	QQSF02SC2785
	TRANSISTOR 2SC2785(H) or	QQSH02SC2785
	TRANSISTOR 2SC2785(J) or	QQSJ02SC2785
	TRANSISTOR KTC3199(GR) or	NQS10KTC3199
	TRANSISTOR KTC3198(GR) or	NQS40KTC3198
	TRANSISTOR 2SC3331(T)-AANP or	2SC3331TZ
	TRANSISTOR 2SC3331(U)-AANP or	2SC3331UZ
	TRANSISTOR 2SC1815-GR(TPE2)	QQS102SC1815
Q1522	TRANSISTOR 2SC5360 or	QQ9Z02SC5360
	TRANSISTOR 2SC4544 or	QQ9Z02SC4544
	TRANSISTOR KTC3229	NQ5Z0KTC3229
Q1531	TRANSISTOR 2SC2785(F) or	QQSF02SC2785
	TRANSISTOR 2SC2785(H) or	QQSH02SC2785
	TRANSISTOR 2SC2785(J) or	QQSJ02SC2785
	TRANSISTOR KTC3199(GR) or	NQS10KTC3199
	TRANSISTOR KTC3198(GR) or	NQS40KTC3198
	TRANSISTOR 2SC3331(T)-AANP or	2SC3331TZ
	TRANSISTOR 2SC3331(U)-AANP or	2SC3331UZ
	TRANSISTOR 2SC1815-GR(TPE2)	QQS102SC1815
Q1532	TRANSISTOR 2SC5360 or	QQ9Z02SC5360
	TRANSISTOR 2SC4544 or	QQ9Z02SC4544
	TRANSISTOR KTC3229	NQ5Z0KTC3229
<b>RESISTORS</b>		
R1501	CARBON RES. 1/4W J 100 Ω or	RCX4JATZ0101
	CARBON RES. 1/6W J 100 Ω	RCX6JATZ0101
R1502	CARBON RES. 1/4W J 100 Ω or	RCX4JATZ0101
	CARBON RES. 1/6W J 100 Ω	RCX6JATZ0101
R1503	CARBON RES. 1/4W J 100 Ω or	RCX4JATZ0101
	CARBON RES. 1/6W J 100 Ω	RCX6JATZ0101
R1509	CARBON RES. 1/4W J 100 Ω or	RCX4JATZ0101
	CARBON RES. 1/6W J 100 Ω	RCX6JATZ0101
R1510▲	METAL RESISTOR 3W J 10k Ω or	RN03103ZU001
▲	FIXED METAL OXIDE FILM RES. 3W J 10k Ω	RN03103DP005
R1511	CARBON RES. 1/4W J 1.5k Ω	RCX4JATZ0152

Ref. No.	Description	Part No.
R1512	CARBON RES. 1/4W J 1.5k Ω	RCX4JATZ0152
R1514	CARBON RES. 1/4W J 100 Ω or	RCX4JATZ0101
	CARBON RES. 1/6W J 100 Ω	RCX6JATZ0101
R1515	CARBON RES. 1/4W J 820 Ω or	RCX4JATZ0821
	CARBON RES. 1/6W J 820 Ω	RCX6JATZ0821
R1518	CARBON RES. 1/4W J 220 Ω or	RCX4JATZ0221
	CARBON RES. 1/6W J 220 Ω	RCX6JATZ0221
R1519	CARBON RES. 1/4W J 100 Ω or	RCX4JATZ0101
	CARBON RES. 1/6W J 100 Ω	RCX6JATZ0101
R1520▲	METAL RESISTOR 3W J 10k Ω or	RN03103ZU001
▲	FIXED METAL OXIDE FILM RES. 3W J 10k Ω	RN03103DP005
R1521	CARBON RES. 1/4W J 1.5k Ω	RCX4JATZ0152
R1522	CARBON RES. 1/4W J 1.5k Ω	RCX4JATZ0152
R1524	CARBON RES. 1/4W J 100 Ω or	RCX4JATZ0101
	CARBON RES. 1/6W J 100 Ω	RCX6JATZ0101
R1525	CARBON RES. 1/4W J 820 Ω or	RCX4JATZ0821
	CARBON RES. 1/6W J 820 Ω	RCX6JATZ0821
R1528	CARBON RES. 1/4W J 220 Ω or	RCX4JATZ0221
	CARBON RES. 1/6W J 220 Ω	RCX6JATZ0221
R1529	CARBON RES. 1/4W J 100 Ω or	RCX4JATZ0101
	CARBON RES. 1/6W J 100 Ω	RCX6JATZ0101
R1530▲	METAL RESISTOR 3W J 10k Ω or	RN03103ZU001
▲	FIXED METAL OXIDE FILM RES. 3W J 10k Ω	RN03103DP005
R1531	CARBON RES. 1/4W J 1.5k Ω	RCX4JATZ0152
R1532	CARBON RES. 1/4W J 1.5k Ω	RCX4JATZ0152
R1534	CARBON RES. 1/4W J 100 Ω or	RCX4JATZ0101
	CARBON RES. 1/6W J 100 Ω	RCX6JATZ0101
R1535	CARBON RES. 1/4W J 820 Ω or	RCX4JATZ0821
	CARBON RES. 1/6W J 820 Ω	RCX6JATZ0821
R1538	CARBON RES. 1/4W J 220 Ω or	RCX4JATZ0221
	CARBON RES. 1/6W J 220 Ω	RCX6JATZ0221
<b>MISCELLANEOUS</b>		
BC1501	BEAD INDUCTORS FBR07HA121TB-00	LLBF00ZTU021
JK1501▲	CRT SOCKET ISHS40ST or	JSCC290PK006
▲	CRT SOCKET HPS0521-012212	JSCC290HD012
JS1551	PCB JUMPER D0.6-P5.0	JW5.0T

SRT2232X

L6650UA

Printed in Japan  
2003-03-20 HO



## Free Manuals Download Website

<http://myh66.com>

<http://usermanuals.us>

<http://www.somanuals.com>

<http://www.4manuals.cc>

<http://www.manual-lib.com>

<http://www.404manual.com>

<http://www.luxmanual.com>

<http://aubethermostatmanual.com>

Golf course search by state

<http://golfingnear.com>

Email search by domain

<http://emailbydomain.com>

Auto manuals search

<http://auto.somanuals.com>

TV manuals search

<http://tv.somanuals.com>