



3825 Ohio Avenue, St. Charles, Illinois 60174
 1-800-SENSOR2, FAX: 630-377-6495
 www.systemsensor.com

DH500ACDC Intelligent Air Duct Smoke Detector Housing

Specifications

Length:	14.5 inches	(36.7 cm.)
Width:	5 inches	(12.7 cm.)
Depth:	4 inches	(10.2 cm.)
Weight:	4 lbs.	(1.8 kg.)
Operating Temperature Range:	32° to 120°F (0° to 49°C)	
Operating Humidity Range:	10% to 93% Relative Humidity	
Duct Air Velocity:	500 – 4000 ft./min. (91.4 – 1219.2 m/min.)	

Power Supply Electrical Ratings For DH500ACDC

Power Requirements	120 VAC (102 - 132) mA rms MAX.		240 VAC (204 - 264) mA rms MAX.		24 VAC (20.6 - 26.4) mA rms MAX.		24 VDC (20 - 30) mA DC MAX.	
	Standby	Alarm	Standby	Alarm	Standby	Alarm	Standby	Alarm
Device								
DH500ACDC	44	52	25	30	65	182	26	87
PA400*	--	3	--	1.5	--	29	--	15
RA400ZA*	--	1.5	--	1	--	17.3	--	10
RTS451/RTS451KEY*	--	1.5	--	1	--	17.3	--	10
RTS451**/RTS451KEY	11.5	13	5.5	6.5	140	157	95	103

The currents shown for the DH500ACDC are maximum values with no accessories.

* All accessory currents are additional to DH500ACDC. There are no additional currents for accessories in standby.

** RTS451/RTS451KEY when the magnet is held in place to initiate an alarm.

24V output maximum load is 80 mA; auxiliary alarm output maximum load is 20 mA.

Auxiliary Relay Contacts

Minimum contact current must be greater than 500 mA at 24 VDC
 10 amps maximum at 30 VDC
 10 amps maximum at 250 VAC

Before Installing

Please thoroughly read the System Sensor Manual I56-473-XX, *Guide for Proper Use of Smoke Detectors in Duct Applications*, which provides detailed information on detector spacing, placement, zoning, wiring, and special applications. Copies of this manual are available at no charge from System Sensor. NFPA Standards 72 and 90A should also be referenced for detailed information.

NOTICE: This manual should be left with the owner/user of this equipment.

IMPORTANT: This detector must be tested and maintained regularly following NFPA 72 requirements. The detector should be cleaned at least once a year.

General Description

An HVAC system supplies conditioned air to virtually every area of a building. Smoke introduced into this air duct system will be distributed to the entire building. Smoke detectors designed for use in air duct systems are used to sense the presence of smoke in the duct.

The DH500ACDC Air Duct Detector Housings are used with System Sensor’s Model 1551 ionization detector heads and Model 2551 photoelectronic detector heads (purchased separately). These two smoke detection methods are combined with an efficient housing design that samples air passing through a duct and allows detection of a developing hazardous condition. When sufficient smoke is sensed, an alarm signal is initiated at the fire control panel monitoring the detector, and appropriate action can be taken to shut off fans and blowers, change over air handling systems, etc. This can prevent the distribution of toxic smoke and fire gases throughout the areas served by the duct system.

Figure 1:

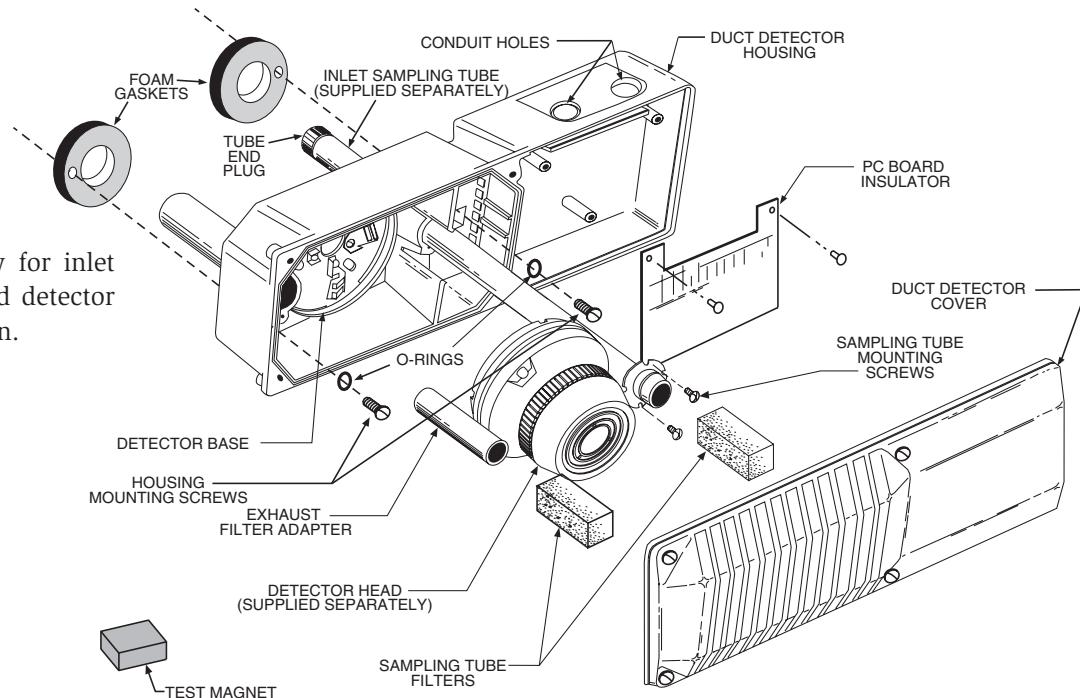

See Note 1 below for inlet sampling tube and detector supply information.

H0309-00

The DH500ACDCs are built to operate on 120/240 VAC or 24 VAC/DC. Two form-C (SPDT) relay contacts are available for control purposes. Two LEDs on each detector latch on to provide a local alarm indication. Remote alarm indication is made possible by using the auxiliary alarm output (see Figure 5). The duct detector can be tested and alarm can be reset by using the correct respective code commands from the panel. See panel instructions for details.

Contents Of The Duct Detector Housing Kit

The DH500ACDC Air Duct Detector Housings consist of the following items: (See Figure 1.)

1. Complete housing base and cover assembly.
2. Two #10 sheet metal mounting screws.
3. Two sampling tube filters.
4. One test magnet.
5. Drilling template.
6. Two 5/16-inch O-rings.
7. Two foam gaskets.
8. Four #6 self-tapping mounting screws for the sampling tube.
9. One filter adapter.
10. One inlet tube end plug.
11. Two #10 speed nuts.

NOTE: The inlet sampling tube must be ordered separately. It must be the correct length for the width of the duct where it will be installed. See Table 1 to determine the inlet tube required for different duct widths. A smoke detector head (1551 ionization or 2551 for photoelectric) must be ordered separately.

Installation Sequence

Page

Step 1. Verify duct air flow direction and velocity.....	2
Step 2. Drill the mounting holes.....	2
Step 3. Mount duct housing.....	3
Step 4. Install the inlet tube.....	3
Step 5. Complete the field wiring.....	5
Step 6. Install the filters.....	7
Step 7. Perform detector check.....	7
Step 8. Install the cover.....	9
Step 9. Perform the final system check (Testing).....	9

Step 1. Verify Duct Air Flow Direction And Velocity

The DH500ACDCA is designed to be used in air handling systems having air velocities up to 500 feet per minute. Be sure to check engineering specifications to ensure that the air velocity in the duct falls within these parameters. If necessary, use a velocity meter to check the air velocity in the duct.

Step 2. Drill The Mounting Holes

Remove the paper backing from the drilling template. Affix the template to the air duct at the desired mounting location. Make sure the template lies flat and smooth on the air duct. Center punch hole targets and remove the template. Drill the holes as indicated on the template. Slide the two speed nuts over the two small holes (Hole A) next to the sampling tube bushing holes (Hole B) previously drilled in the duct. (See Figure 2.)

Location of detectors mounted in or on air ducts should be at least six duct widths downstream from any duct openings, deflection plates, sharp bends, or branch connections.

Figure 2. Speed nut mounting location:

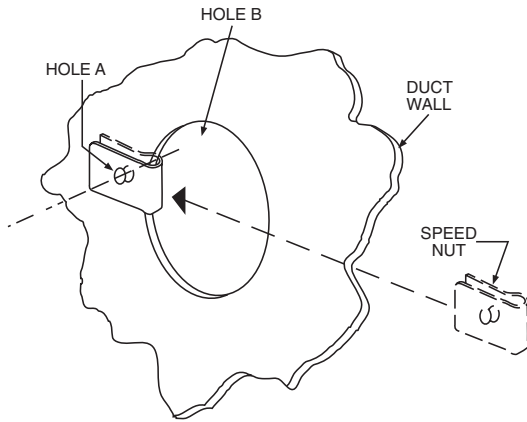

H0116-00

Figure 2A. Installation of foam gaskets over sampling tube bushings:

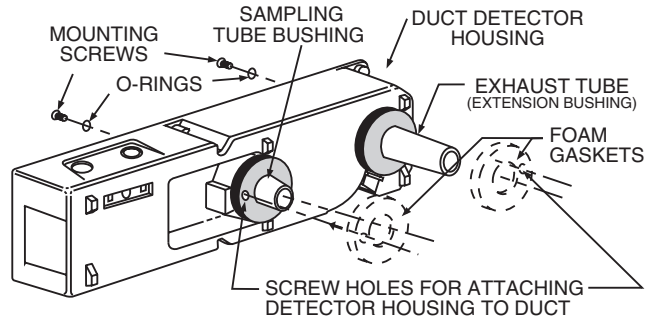

H0117-00

CAUTION: Do not overtighten the screws.

Exception: Where it is physically impossible to locate the detector accordingly, the detector can be positioned closer than six duct widths, but as far as possible from the opening, bend, or deflection plates.

Step 3. Mount Duct Housing

Remove the duct housing cover. Slide the foam gaskets over the tube bushings as shown in Figure 2A. Make sure the two small holes in the gaskets line up with the two duct housing mounting holes. Put one 5/16-inch O-ring over each of the two #10 sheet metal screws. Use the two sheet metal screws to secure the duct housing to the duct.

Table 1. Sampling (Inlet) Tubes

TUBE	OUTSIDE DUCT WIDTH	
ST-1.5	1 to 2 ft.	(0.3 to 0.6 m)
ST-3	2 to 4 ft.	(0.6 to 1.2 m)
ST-5	4 to 8 ft.	(1.2 to 2.4 m)
ST-10	8 to 12 ft.	(2.4 to 3.7 m)

Step 4. Install The Inlet Tube

The inlet tube (shown in Figure 3) is identified by a series of air inlet holes on the tube. This tube must be purchased separately. Order the correct length, as specified in Table 1, for the width of the duct where it will be installed. The exhaust tube is molded into the base of the duct housing.

The inlet tube should be installed in the inlet sampling tube bushing located in the center of the duct detector housing. (See Figure 2A.) The air inlet holes must face into the air flow. To assure proper installation, the tube mounting flange is marked with arrows. Mount the inlet tube so that the arrows point into the air flow. Figure 4 shows the various combinations of duct detector and tube mounting configurations with respect to air flow.

Figure 3. Air duct detector inlet sampling tube:

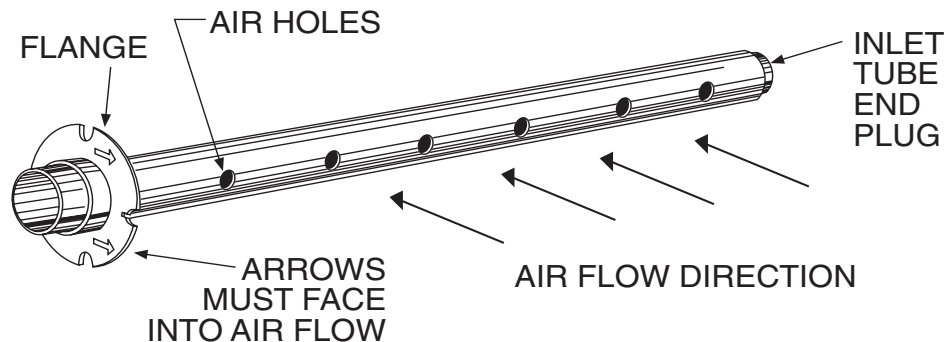

H0108-00

Figure 4. Tube mounting configurations with varying air flow direction and orientation of detector housing. Vertical as well as horizontal mounting is acceptable.

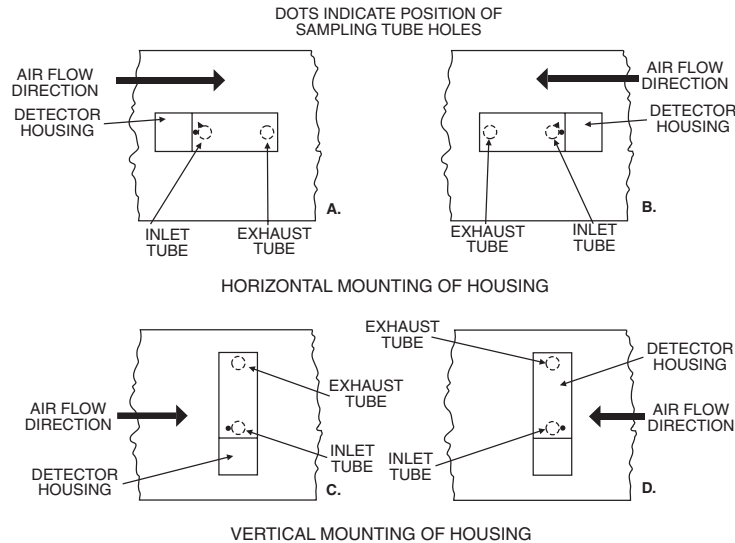

H0109-00

A. Installation for Ducts Less Than 8 Feet Wide

1. If the inlet tube is longer than the width of the air duct, drill a 3/4-inch hole in the duct directly opposite the hole already cut for the inlet tube.

If the inlet tube is shorter than the width of the air duct, install the end cap into the inlet tube as shown in Figure 3.

- Slide the inlet tube into the bushing located in the center of the duct housing. Position the tube so that the arrows point into the air flow.
- Secure the tube flange to the housing bushing with the two #6 self-tapping screws.
- For tubes longer than the width of the air duct, the tube should extend through the opposite side of the duct. If there are more than 2 holes in the section of the tube extending from the duct, select a different tube length using Table 1. Otherwise, trim the end of the tube protruding through the duct so that 1 to 2 inches of the tube extends outside the duct. Plug this end with the tube end plug and tape closed any holes in the protruding section of the tube. Be sure to seal the duct when the tube protrudes.
- Any inlet tube over 3 feet long must be supported on the opposite side of the duct detector housing.



In no case should more than 2 air inlet holes be cut off the tube. There must be a minimum of 10 holes in the tube exposed to the air stream.

B. Installation for Ducts More Than 8 Feet Wide

NOTE: To install inlet tubes in ducts more than 8 feet wide, work must be performed inside the air duct. Sampling of air in ducts wider than 8 feet is accomplished by using the ST-10 inlet sampling tube.

Install the inlet tube as follows:

- Drill a 3/4-inch hole in the duct directly opposite the hole already drilled for the inlet tube.
- Slide the inlet tube into the bushing located in the center of the duct housing. Position the tube so that the arrows point into the air flow. Secure the tube flange to the housing bushing with the two #6 self-tapping screws.
- From inside the duct, couple the other section of the inlet tube to the section already installed using the 1/2-inch conduit fitting supplied. Make sure that the holes on both of the air inlet tubes are lined up facing the direction of air flow.
- Trim the end of the tube protruding through the duct so that 1 to 2 inches of the tube extends outside the duct. Plug this end with the tube end plug and tape closed any holes in the protruding section of the tube. Be sure to seal the duct when the tube protrudes.
- Any tube (over 3 feet long) that doesn't protrude through the duct (on the side opposite the housing) must be supported by other means.

NOTE: An alternate method to using the ST-10 is to use two ST-5 inlet tubes. Remove the flange from one of the tubes and install as described above. After the installation, use electrician's tape to close off some of the sampling holes so that there are a total of 12 holes spaced as evenly as possible across the width of the duct.

NOTE: Air currents inside the duct may cause excessive vibration. This vibration can slowly open the seal around the tube and permit air to escape. To prevent this from occurring, a 3-inch floor flange,

available at most plumbing supply houses, may be used. This flange/connector mounting technique makes the initial installation easier because a 1-inch to 1-1/4-inch hole may be drilled where the flange/connector will be used. It is easier to push the inlet tube through the larger hole.

Modification Of Inlet Sampling Tubes

There may be situations where duct widths are not as specified for the installation. In such cases, it is permissible to modify an inlet sampling tube that is longer than necessary to span the duct width.

Use a 0.193-inch diameter (#11) drill and add the appropriate number of holes so that the total number of holes exposed to the air flow in the duct is 10 to 12. Space the additional holes as evenly as possible over the length of the tube.

Step 5. Field Wiring

Wiring Installation Guidelines

All wiring must be installed in compliance with the National Electrical Code and the local codes having jurisdiction, using the proper wire size(s). The conductors used to connect smoke detectors to control panels and accessory devices should be color-coded to reduce the likelihood of wiring errors. Improper connections can prevent a system from responding properly in the event of a fire.

For signal wiring, (the wiring between interconnected detectors or from detectors to auxiliary devices), it is recommended that single-conductor wire be no smaller than 18 gauge. The duct detector terminals accommodate wire sizes up to 14 gauge. The last foot or so of conduit should be flexible steel conduit (available in electrical supply houses) which facilitates installation and puts less strain on the conduit holes in the housing. Solid conduit connections may be used, if desired.

Smoke detectors and alarm system control panels have specifications for allowable loop resistance. Consult the control panel manufacturer's specifications for the total loop resistance allowed for the control panel being used before wiring the detector loop.

Wiring Instructions

The DH500ACDC is designed for easy wiring. The housing provides a terminal strip with clamping plates. Wiring connections are made by stripping approximately 3/8-inch of insulation from the end of the wire, sliding this bare end under the plate, and tightening the clamping plate screw.

The DH500ACDC is built for 120/240 VAC or 24 VAC/DC to operate auxiliary functions. See Figure 5A for operating and wiring details.

Notes on Jumper Wire J5 (See Figure 5A):

1. When the detector is used in a 4-wire application (relay circuit is being used to control fans, dampers, etc.), jumper wire J5, located between the two terminal strips on the printed circuit board, must be cut to insure power supply supervision.
2. When the detector is used in a 2-wire application (relay control is not being used for any control of fans, dampers, etc.), jumper wire J5 must be left in place.

120/240 VAC Operation

To complete the wiring for 110/120 VAC operation, connect the power supply wires to terminals 15 and 16 (see Figure 5A). If 220/240 VAC operation is preferred, connect the power supply wires to terminals 16 and 17.

24 VAC/DC Operation

To complete the wiring for 24 VAC or DC, connect the power supply wires to terminals 7 and 8. Polarity is not important.

Step 6. Install the Filters

Most duct installations are subject to dust accumulation. System filters remove a large percentage of this contamination, but cannot remove all of it. Dust inside the duct detector causes problems. First, very fine particles of dust can enter the detector sensing chamber and cause the unit to alarm. Second, the accumulation of dust and dirt necessitates a more frequent periodic cleaning schedule, which can result in substantial cost and/or down time.

Disposable sampling tube filters can greatly reduce the nuisance alarms caused by dust, and can also significantly extend the maintenance interval. To install the sampling tube filters, insert the filter adapter into the exhaust tube and push the filter onto the adapter tube on the left, as shown in Figure 6. Then, install the other filter over the end of the inlet sampling tube.

CAUTION

Filters require periodic cleaning or replacement, depending on the amount of dust and dirt accumulated. Inspect the filters at least quarterly – more often if dust accumulation warrants it. Replacement filters can be ordered from Notifier. (Exhaust tube/intake tube filter P/N F36-05-00.)

Filters rarely have a significant effect on the behavior of smoke. As a result, even a filter that is as much as 90% clogged does not significantly affect the entry of smoke into the duct detector housing. Therefore, visual inspection is usually all that is necessary to determine if filters need replacement.

Figure 5. Wiring diagram:

ACCESSORY CURRENT LOADS AT 24VDC			
DEVICE	STANDBY	ALARM	
PA400	0mA	15mA MAX	
RA400Z	0mA	10mA MAX	
RTS451/RTS451KEY	0mA *	10mA MAX *	

ANY COMBINATION OF ACCESSORIES MAY BE USED SUCH THAT THE GIVEN CURRENT LOADS TOTAL:

STANDBY STATE: 30mA OR LESS

ALARM STATE: 80mA MAX, 24 VDC (TERMINALS 3 & 6)

20mA MAX; AUXILIARY ALARM OUTPUT (TERMINALS 2 & 6).

*NOTE: WHEN INITIATING AN ALARM, THE RTS451/RTS451KEY REQUIRES 95mA MAXIMUM IN PRE-ALARM AND 103mA MAXIMUM IN ALARM. NOMINAL STANDBY CURRENT IS 0mA. ALARM CURRENT IS 8mA MAXIMUM WHEN TEST MAGNET IS REMOVED.

Figure 5B

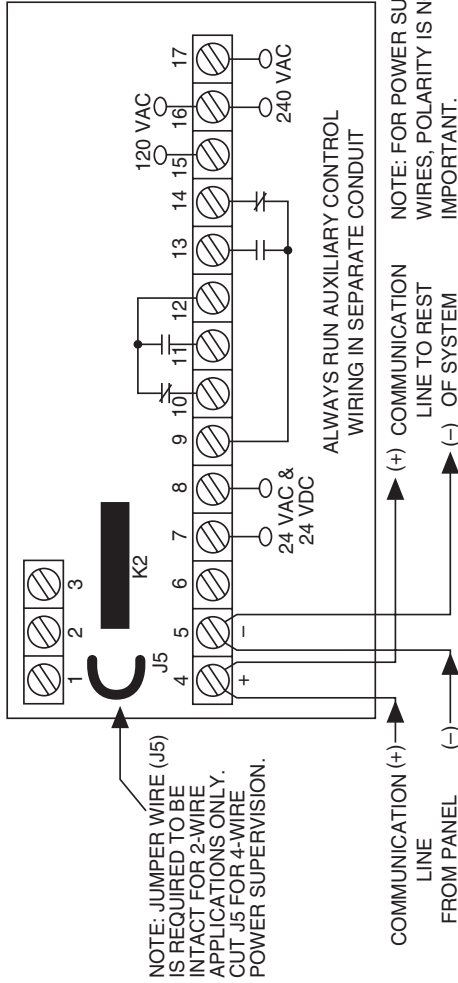

Figure 5A

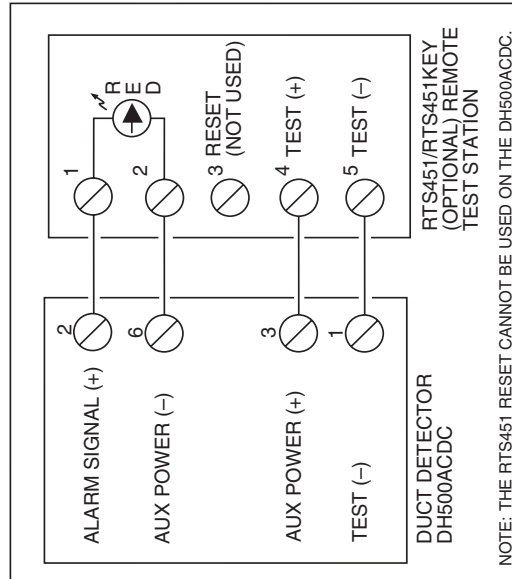

Figure 5C

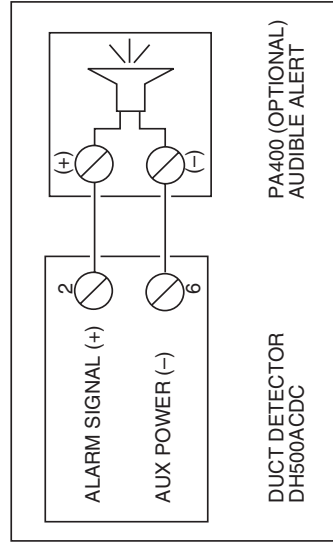

Figure 5D

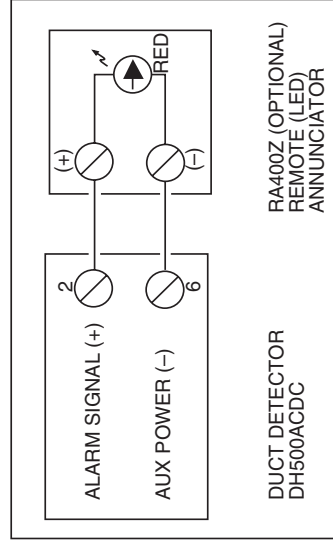

Figure 5E

NOTE: Auxiliary devices (RA400Z, PA400, RTS451/RTS451KEY) and auxiliary control contacts will not function without auxiliary power. See Figure 5A for voltage/termination.

Step 7. Perform Detector Check

7.1 Air Flow

1. To verify sufficient sampling of ducted air, use a manometer to measure the differential pressure created from air flow across the sampling tubes. The pressure should measure no less than 0.01 inches of water and no greater than 1.20 inches of water.
2. To determine that smoke is capable of entering the sensing chamber, conduct a visual examination to note any obscurations around the sensing chamber. If a smoke test is required, blow smoke from a cigarette, cotton wick, or punk directly at the smoke detector head. It is important to plug the exhaust and sampling tube hole to prevent ducted air from blowing smoke away from the smoke detector head. Record all test records in the Detector Test Log at the end of this manual.

CAUTION

Remove the plugs after testing or the detector will not sense smoke in the air duct.

7.2 Alarm Tests

Before replacing the duct housing cover, check the detector interconnections. Check the DH500ACDC as follows:

- A. M02-04-00 Magnet Test
 1. Make sure power is applied to the detector.
 2. Position the painted surface of the test magnet against the housing next to the rib molded onto the outside of the housing (see Figure 7).
 3. The LEDs on the detector should latch on as should any accessories (PA400, RA400ZA, RTS451) and the alarm condition verified at the control panel. The control panel must be active to initiate an alarm.

Figure 6. Sampling tube filter installation:

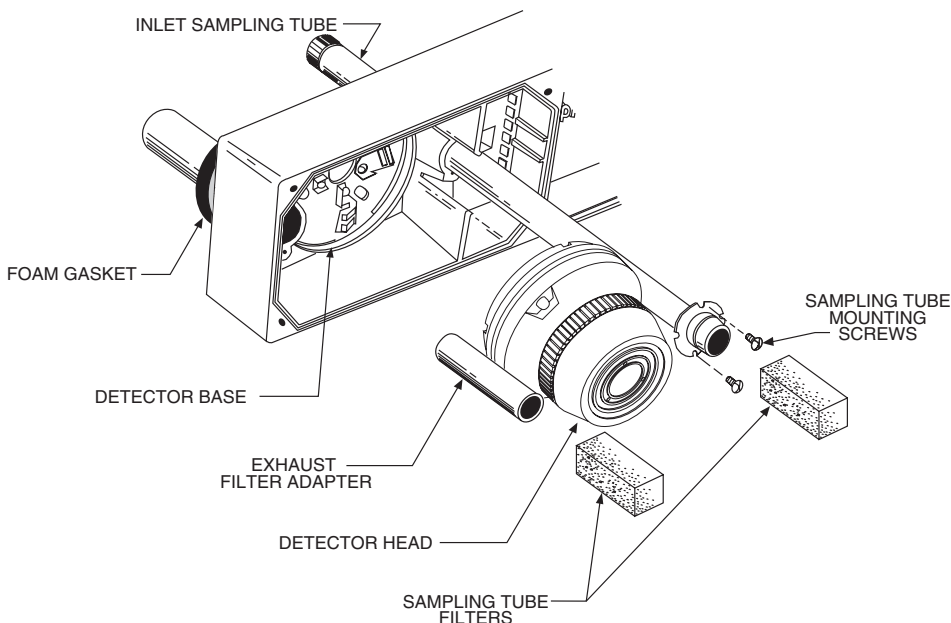

H0239-00

B. RTS451/RTS451KEY Remote Test Station

The RTS451/RTS451KEY Remote Test Station facilitates testing of the duct detector alarm capability. The DH500ACDC duct detector cannot be reset by the RTS451/RTS451KEY. It must be reset at the system control panel.

To install the RTS451/RTS451KEY test coil, connect the device as shown in Figure 9. Place the coil in the detector housing with the arrow facing up and pointing toward the detector as in Figure 9. Attach the coil leads to the housing terminals as shown; polarity is not important. Firmly screw the test coil mounting bracket in place over the test coil. The resistance of the wire connecting the remote test station to the duct detector must be less than 25 ohms.

7.3 MOD400R Sensitivity Test

After verification of alarm capability, use a MOD400R test module with a voltmeter to check detector sensitivity as described in the MOD400R installation manual. The housing cover must be removed to perform this test.

If the MOD400R readings indicate that the sensor head is outside of the acceptable range, the sensor heads require cleaning (refer to **Periodic Maintenance Requirements**).

7.4 Trouble Test

The capability of trouble detection is tested by removing the detector head from the duct housing. The detector head is removed by rotating it counterclockwise about 10 degrees (Figure 8). The system control panel should indicate a trouble condition. Reinstalling the detector head should clear the trouble condition.

Figure 7. Testing detector alarm:

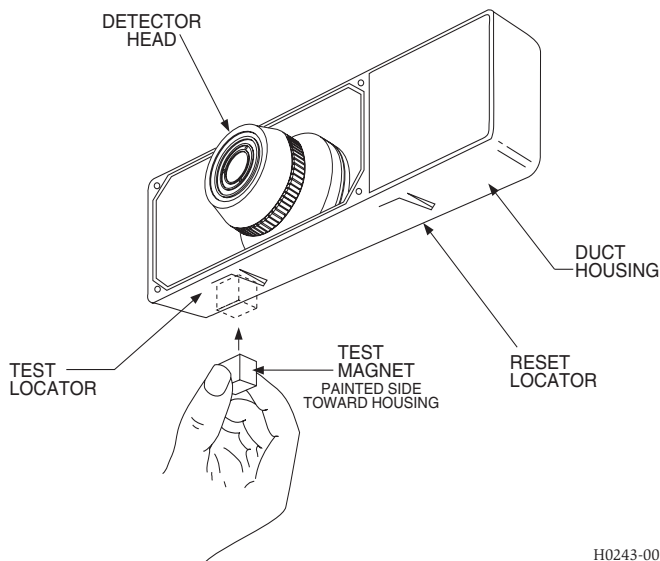

H0243-00

Figure 8. Detector head removal:

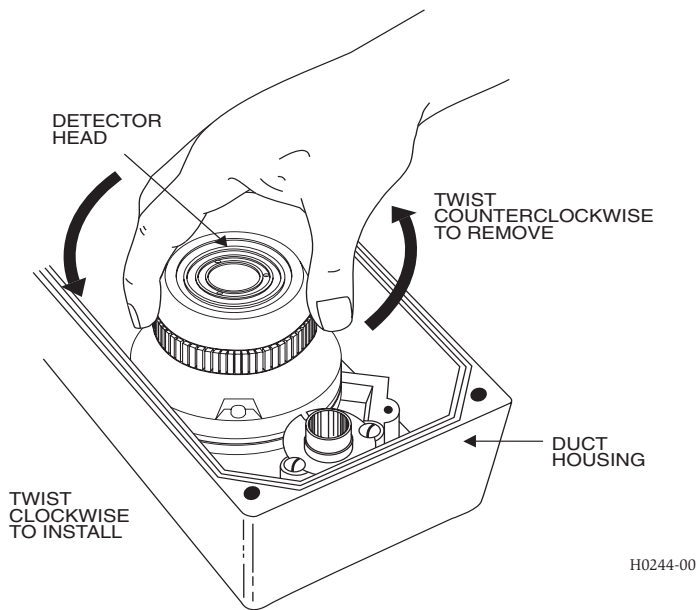

H0244-00

Step 8. Install the Cover

Install the cover using the four screws. Be certain filters are installed as specified in Step 6. Make sure that the cover fits into the base groove and that all gaskets are in their proper positions. Tighten the four cover screws to 10 in-lbs.

Step 9. Perform the Final System Check

Position the test magnet as shown in Figure 7. The LEDs on the detector should light. Any accessory LED(s) should also light and the system control panel should indicate an alarm condition.

Periodic Maintenance Requirements

Air duct smoke detectors should be maintained at least once a year – more often if the detector heads become obviously dirty. The detectors must also be cleaned immediately after a fire. Failure to properly maintain air duct smoke detectors may cause unnecessary false alarms.

It is recommended that a permanent Detector Test Log be set up and maintained, with a record for each individual smoke detector in each building. Each detector should be clearly described, with information on the type of detector, the model number, the serial number (if any), the location, and the type of environment. Data entries should include test dates, type of test mode, test results, maintenance, and comments. A Detector Test Log is included at the end of this manual.

Recommended Detector Maintenance Procedure

NOTE: Notify the proper authorities that the smoke detector system is undergoing maintenance and will be temporarily out of service. Disable the zone or system undergoing maintenance to prevent unwanted alarms and possible dispatch of the fire department.

Figure 9. RTS451/RTS451KEY Test Coil Installation:

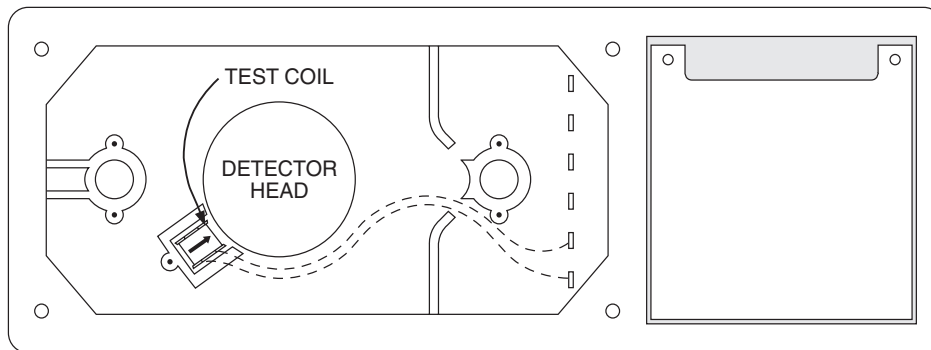

H0245-0

1. Turn off power to the system.
2. Remove and inspect sampling tube filters.
3. If filters are heavily coated with dirt, replace them with new filters. If they are not heavily coated, use a vacuum cleaner or compressed air nozzle to remove dust, then install the filters.
4. Remove the detector from the housing. (See Figure 8.)

Photo Units

5. Remove the detector cover by inserting a small-bladed screwdriver into the slot located approximately 90 degrees from the MOD400 test jack. Rotate the cover counterclockwise to remove it. See Figure 10.
6. Lift the screen from the photo chamber. Vacuum the screen and cover before using clean, compressed air to loosen and blow out any remaining debris (replacement screens are available, part no. RS24).
7. Vacuum the photo chamber. Then, use clean compressed air to blow it clean.
8. Replace the screen by aligning the arrow on top with the test slot in the base of the detector. Press the screen into place. It should fit tightly in the chamber.

Ion Units

9. See Figure 11. Remove the cover and screen assembly by depressing the three lock prongs on the top of the cover and rotating the cover counterclockwise. The CRT400 Cover Removal Tool makes cover removal easier.
10. Carefully pull the screen out of the cover.
11. Clean the screen thoroughly with a soft brush or vacuum cleaner (replacement screens, part no. RS14).

12. Brush or vacuum the inside of the cover. The cover may then be blown out using clean compressed air.
13. Vacuum the sensing chamber before using clean, compressed air to loosen and blow out any remaining debris.
14. Press the screen back into the cover.
15. Replace the detector cover on the sensing chamber. Rotate it clockwise to lock it in place.

Both Types Of Units

16. Reinstall the detector in its housing.
17. Restore system power.
18. Put detector into alarm using appropriate method described in STEP 7.

Perform Detector Check

19. Notify the proper authorities that testing has been completed and the smoke detector system is back in operation.
20. Other checks that should be made during maintenance procedures:
 - Holes or cracks in duct work near vicinity of detector.
 - Air leaks where detector housing or sampling tubes are attached to duct.
 - Dust accumulations in or on sampling tubes.
 - Wiring terminal screw tightness.

Figure 10. Photo head exploded view:

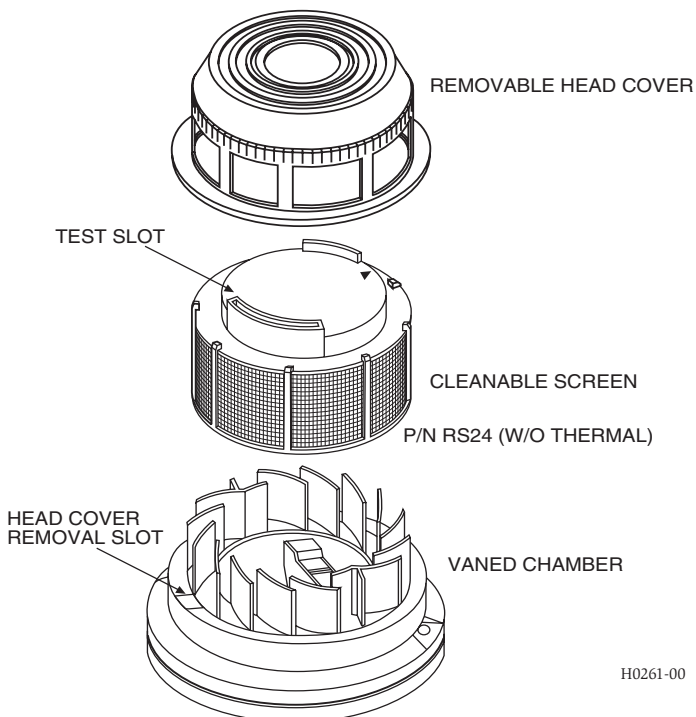
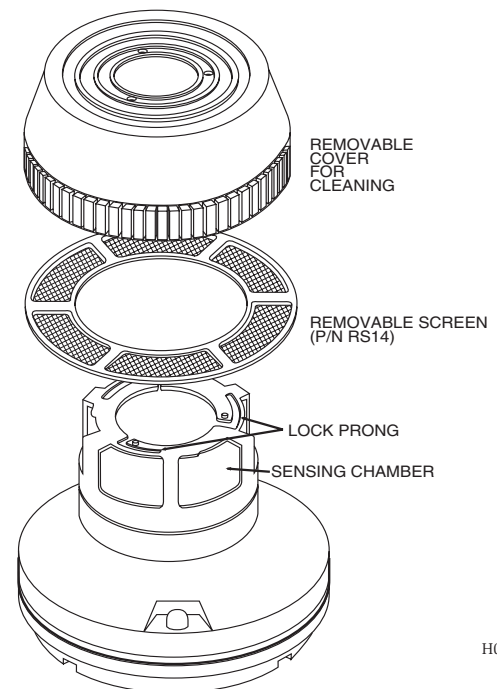

Figure 11. Ion head, exploded view:



Accessories

	Part No.
Remote LED	RA400ZA
Piezo Alert Sounder	PA400
Replacement Filters	F36-05-00
Magnet	M02-04-00
End Plug For Sampling Tube	P48-21-00
Installation Kit (Parts bag)	A2650-01
Ionization Replacement Screen	RS14
Sensitivity Test Kit	MOD400R
Ionization Cover Removal Tool	CRT400
Remote Test Station	RTS451/RTS451KEY

Programming Specifications/Requirements For Intelligent System Control Panels



Models 1551 and 2551 can be used with the DH500ACDC if the following constraints are observed.

1. There may be a limit to the number of devices per zone that can have their LEDs latched on. The number of devices is determined by the control panel and its ability to supply LED current. If more than the maximum number of devices is on the same loop, do NOT use the DH500ACDC for control purposes. Control for duct applications would need to come directly from the control panel or by using control modules.

2. The duct control circuitry (auxiliary relay contacts and auxiliary alarm output) may change states if the sensor is tested and the LED is turned on for more than 4 seconds. If the LED is latched on for less than 4 seconds, the control circuitry of the DH500ACDC will NOT operate.
3. The panel must not poll the same unit for more than 4 seconds continuously or the auxiliary relay and auxiliary alarm output may switch states. After 4 seconds of continual polling of a device, the panel must wait a minimum of 100ms before polling or communicating to that same device.
4. Communications must not cease for more than 3 seconds without an additional clock pulse (after Pulse Width 5) to turn off the LED on the sensor.
5. To allow the auxiliary relay and auxiliary alarm output to return to a standby condition, (after being in alarm) the panel must wait a minimum of 100ms after turning off the sensor LED before communicating to that device again.

Please refer to insert for the Limitations of Fire Alarm Systems

Three-Year Limited Warranty

System Sensor warrants its enclosed air duct smoke detector to be free from defects in materials and workmanship under normal use and service for a period of three years from date of manufacture. System Sensor makes no other express warranty for this air duct smoke detector. No agent, representative, dealer, or employee of the Company has the authority to increase or alter the obligations or limitations of this Warranty. The Company's obligation of this Warranty shall be limited to the repair or replacement of any part of the air duct smoke detector which is found to be defective in materials or workmanship under normal use and service during the three year period commencing with the date of manufacture. After phoning System Sensor's toll free number 800-SENSOR2 (736-7672) for a Return Authorization number, send defective units postage prepaid to: System Sensor, Repair Department, RA # _____, 3825 Ohio

Avenue, St. Charles, IL 60174. Please include a note describing the malfunction and suspected cause of failure. The Company shall not be obligated to repair or replace units which are found to be defective because of damage, unreasonable use, modifications, or alterations occurring after the date of manufacture. In no case shall the Company be liable for any consequential or incidental damages for breach of this or any other Warranty, expressed or implied whatsoever, even if the loss or damage is caused by the Company's negligence or fault. Some states do not allow the exclusion or limitation of incidental or consequential damages, so the above limitation or exclusion may not apply to you. This Warranty gives you specific legal rights, and you may also have other rights which vary from state to state.

Free Manuals Download Website

<http://myh66.com>

<http://usermanuals.us>

<http://www.somanuals.com>

<http://www.4manuals.cc>

<http://www.manual-lib.com>

<http://www.404manual.com>

<http://www.luxmanual.com>

<http://aubethermostatmanual.com>

Golf course search by state

<http://golfingnear.com>

Email search by domain

<http://emailbydomain.com>

Auto manuals search

<http://auto.somanuals.com>

TV manuals search

<http://tv.somanuals.com>