

TAMRON

AF 70~300 mm F/4-5.6

Di LD Macro 1:2

(Model A17)



Thank you for purchasing the Tamron lens as the latest addition to your photographic equipment. Di II lens (Digitally Integrated) series are designed for digital SLR cameras with image sensors equivalent to APS-C size. Before using your new lens, please read the contents of this Owner's Manual thoroughly to familiarize yourself with your lens and the proper techniques for creating the highest quality images possible. With proper handling and care, your Tamron lens will give you many years of photographing beautiful and exciting pictures.

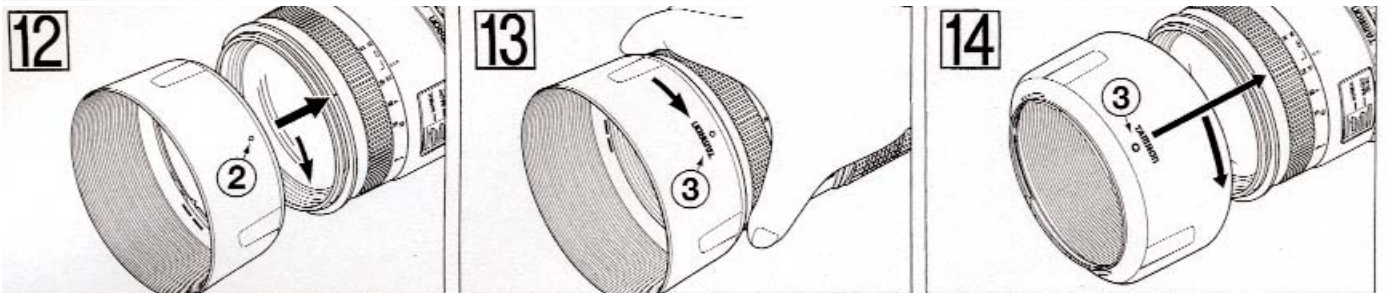
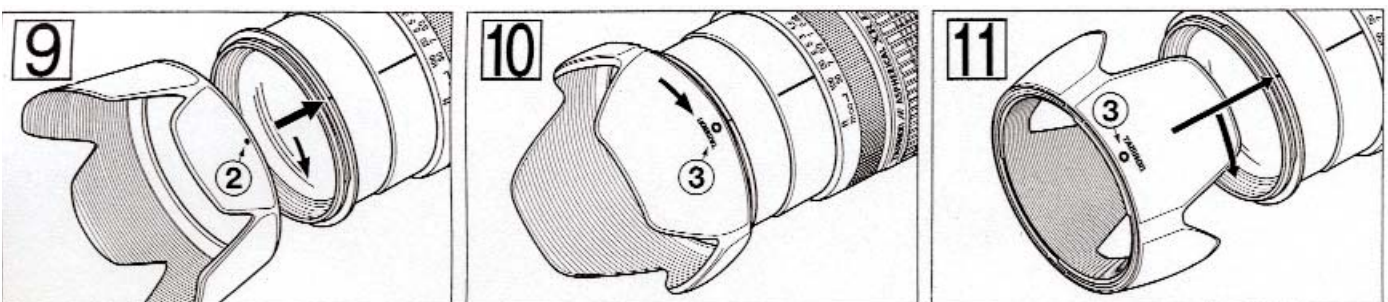
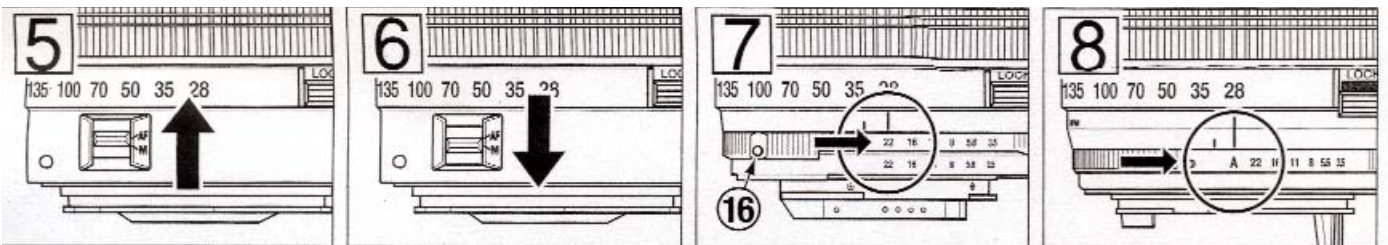
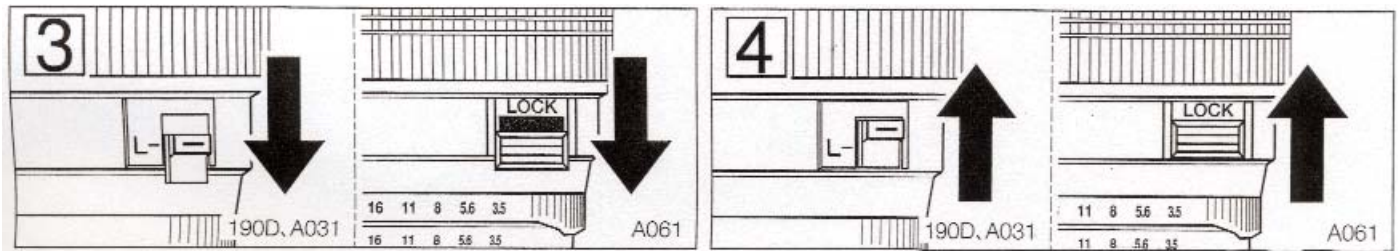
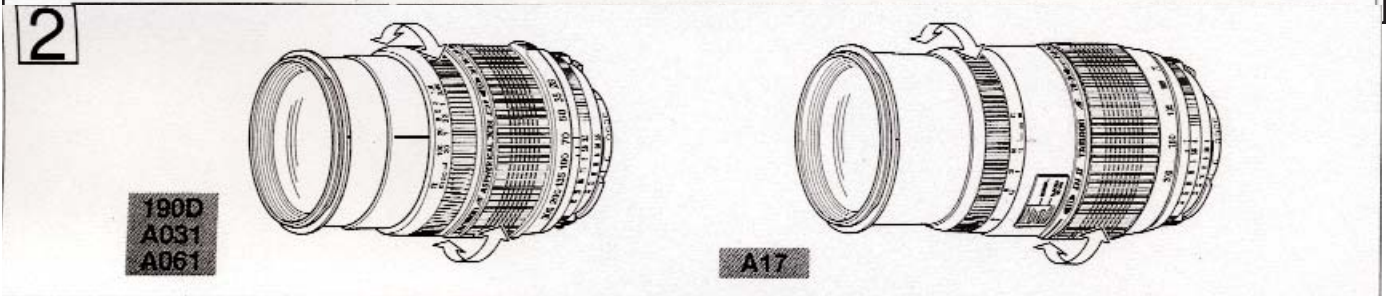
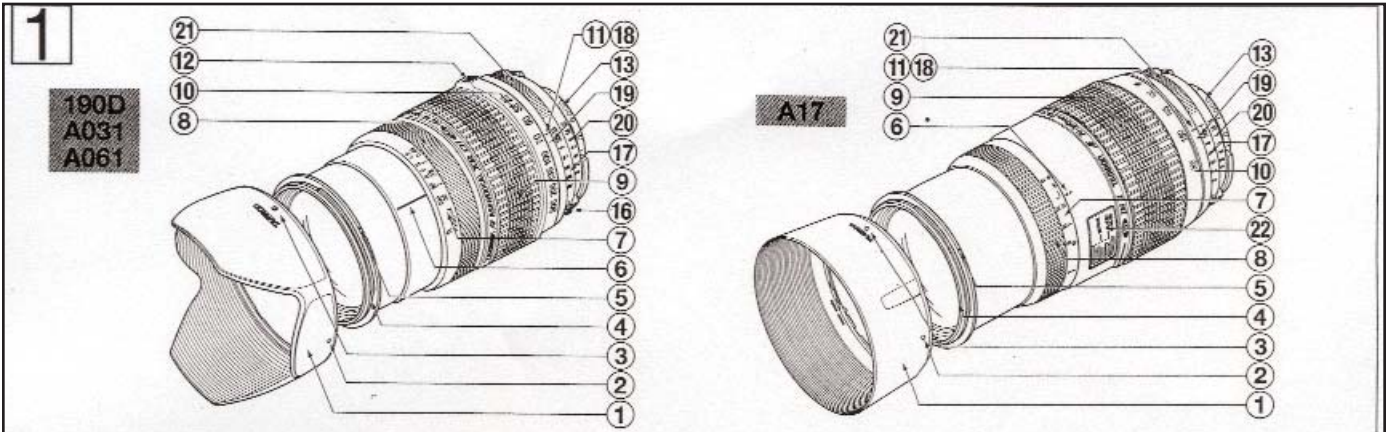

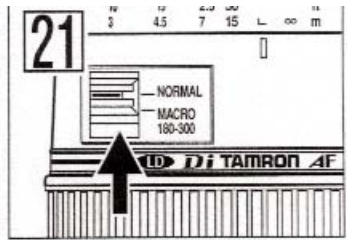
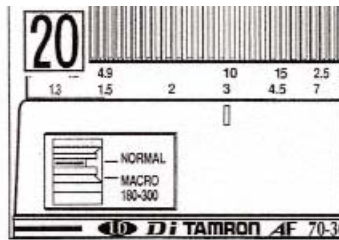
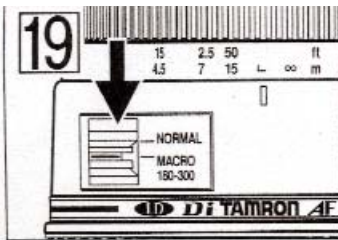
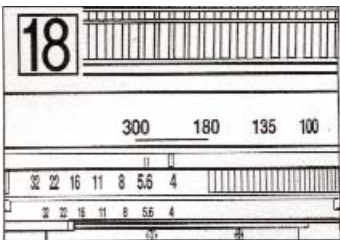
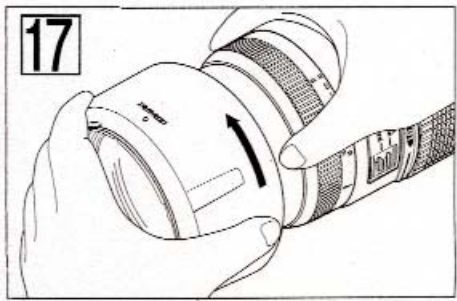
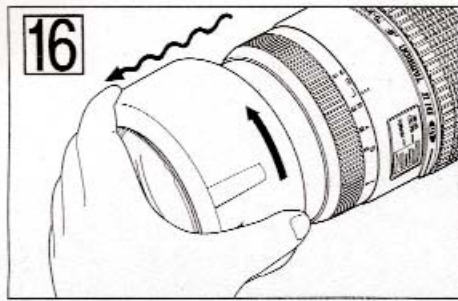
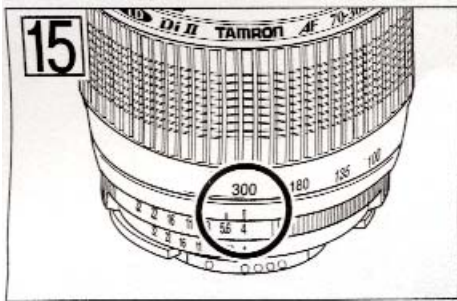

NOMENCLATURE

1. Lens Hood
2. Hood attaching alignment mark
3. Hood attaching indicator
4. Filter Ring
5. Hood attaching bayonet ring
6. Distance index
7. Distance scale
8. Focusing ring
9. Zooming ring
10. Focal length scale
11. Zoom index mark
12. Zoom lock switch
13. Lens mount/Lens mount contacts (Nikon)
14. AF-MF altering switch (Canon Fig 5 & 6)
15. Lens attachment mark
16. AE (minimum aperture) lock
17. Aperture scale
18. Aperture index
19. F-number index mark for long focal lengths (Nikon, Pentax)
20. F-number scale for finder display (Nikon)
21. Aperture ring
22. Macro selector switch

SPECIFICATIONS

	A17
Focal Length	70-300mm
Maximum Aperture	F/4-5.6
Angle of View	34° 21' - 8° 15'
Lens Construction	9/13
Minimum Focus Distance	1.5m
Max. Magnifications Ratio	1:3.9
Filter Size	62mm
Length	116.5mm
Diameter	76.6mm
Weight	435g
Hood	DA17

* Lengths and weights listed in lens specifications are for lenses with Nikon mounts.
* Features and cosmetic designs of lenses listed in this owner's manual may be revised without notice.

ATTACHING AND REMOVING THE LENS

How to mount the lens

Remove the rear cap of the lens. Align the lens attachment mark (15) on the lens barrel with its counterpart on the camera mount and insert the lens. Rotate the lens clockwise until it click-locks. For Nikon, Sony and Pentax models, align the lens attachment mark on the camera and zoom index (11) on the lens to attach the lens. For Nikon models, align the lens attachment mark with the dot on the camera and rotate the lens counter-clockwise until it click-locks.

How to detach the lens

Pressing the lens release button on the camera down, turn the lens counter-clockwise (in case of Nikon lens, clockwise), and lift the lens off the camera's lens mount.

For further details, please read the instruction manual of your camera.

FOCUSING (Autofocus) (Ref. Figs 1 & 2)

Switch the focusing mode switch of the camera to Auto focusing mode (AF) in case of Nikon, Sony, or Pentax. In case of Canon camera, switch the AF/MF switch (14) on the lens to AF. (Fig. 5). Press the shutter button lightly while viewing through the camera's viewfinder, the lens focuses automatically. An in-focus mark will light when the lens focuses on the main subject sharply. Press the shutter button further to photograph.

When set on AF mode, interfering with focusing ring (8) may cause serious damage to the lens mechanism.

For further details, please read the instruction manual of your camera.

FOCUSING (Manual focus) (Ref. Figs 1, 2 & 6)

Switch the focusing mode switch of the camera to manual focusing mode (MF) in case of Nikon, Sony, or Pentax. In case of Canon camera, switch the AF/MF switch (14) on the lens to MF. (Fig. 6). Focus manually by rotating the focusing ring while viewing through the camera's viewfinder. The main subject in the viewfinder will be sharp when the lens is focused correctly.

Even in the MF mode, turning the focusing ring (8) while pressing the shutter button halfway the focus aid function lamp lights up when the picture is in focus.

At infinity, make sure the image in the viewfinder appears sharp. The infinity position is made with certain allowances to insure proper focus under a variety of conditions.

For further details, please read the instruction manual of your camera.

ZOOMING (Ref. Figs.1 & 2)

Rotate zooming ring (9) of the lens while viewing through the camera's viewfinder and compose your image at the chosen focal length.

LENS APERTURE AND AE MODE (Ref. Figs. 1, 7, & 8)

Setting lens f-numbers with Canon & Sony cameras

Set the f-number with aperture setting device of the camera body in accordance with the selected photographing mode.

For further details, please read the instruction manual of your camera.

Setting lens f-numbers with Nikon & Pentax cameras

Photographing in a programmed-AE or a shutter-speed-priority-AE mode. Rotate the lens aperture ring (21) to the minimum aperture position, in case of Nikon camera, and set on the "A" position in case of a Pentax camera. The aperture ring will be locked in position automatically. When shooting in an aperture-priority-AE or manual-exposure mode, release the lens aperture ring lock button.

The lens aperture varies with zooming movement. Cameras read the different lens openings and automatically adjust the exposure properly.

For further details, please read the instruction manual of your camera.

If your camera is a Nikon F401 or F50, you can set the aperture to any desired f-number, leaving the aperture ring at the minimum opening position.

Lens Hood (Ref. Figs. 1, 12 to 17)

When attaching and detaching the lens hood for the A17, be sure to set your camera or lens to MF mode. The hood attaching bayonet ring (5) turns as the the focusing ring (8) turns. Trying to attach the lens hood when the camera or lens is set in AF mode forces the focusing ring (8) to turn and will damage the camera or lens.

Attaching the Lens Hood (Ref. Figs. 12 & 13)

1. For Nikon, Sony, or Pentax cameras, set the camera to the MF mode. For Canon cameras, set the AF-MF switch (14) on the lens to the MF position.
2. Align the hood attaching alignment mark (2) on the hood with the corresponding index mark (5) or the top of the index line of the distance scale on the lens. Press the hood lightly onto the hood attaching bayonet ring (Fig. 12) and then rotate it clockwise to secure (Fig. 12). The lens hood will be securely held as the mark (TAMRON O) comes to the top (Fig. 13). When attaching the lens hood, hold the focusing and zoom control rings so that they are not rotated unintentionally.

Detaching the lens hood

1. For Nikon, Sony, and Pentax cameras, set the camera to the MF position. For Canon cameras, set the AF-MF switch (14) on the lens to the MF position.
2. Secure the focusing ring (8) from moving while turning the lens hood (1) counter-clockwise, until the hood is released from the lens.

Stowing lens hood on the lens (Ref. Fig. 14)

*The lens hood can be reverse-mounted for easy storage.

1. For Nikon, Sony, and Pentax cameras, set the camera to the MF mode. For Canon cameras, set the AF-MF switch (14) to the MF position.
2. Reverse the lens hood. Point the lens toward to opening, then align the hood (5) on the lens with the (TAMRON O) alignment on the hood (3).
3. Turn the hood clockwise until the alignment mark is at the top to set it. (Fig. 14)

Detaching the stored lens hood from the lens (Ref. Fig. 15 to 17)

1. For Nikon, Sony, and Pentax cameras, set the camera to the MF mode. For Canon cameras, set the AF-MF switch (14) to the MF position.
2. Set the zoom index mark (11) at 300mm on the zooming ring (9).
3. Hold the extended portion of the focusing ring (8) to secure from moving while turning the hood (1) counter-clockwise until the hood is released.

Switching to Macro Photography (Ref. Figs. 1, 18 to 21)

The model A17 allows macro photography by operating the macro selector switch.

Switching to Macro Photography

First, turn the zoom ring to align the zoom between 180-300mm. Next, slide the macro switch (22) from the Normal to the Macro position. The lens is now switched to macro photography mode.

The macro selector switch (22) cannot be operated unless the zooming ring (9) is between 180mm, and 300mm. Always make sure to align the zoom ring between 180mm and 300mm before operating the macro selector switch.

When in the macro photography mode, the zoom ring can only be rotated over the range of 180-300mm.

When in the macro photography mode, the focusing ring rotates continuously from infinity to the minimum focus distance of 0.95m.

The maximum magnification ratio in the macro photography mode is 1:2 ($f=300\text{mm}$, 0.95m)

Cancellation of Macro Photography

First, check that the focusing ring (8) is aligned to 1.5m or farther (1.5 - infinity). Next, slide the macro selector switch (22) from the Macro position to the normal position. The macro photography mode is now cancelled.

The macro selector switch (22) cannot be operated unless the focusing ring (8) is set to a distance between 1.5m and infinity. Always make sure to align the focus ring is set between 1.5m and infinity before operating the macro selector switch.

The focus ring can only be turned between infinity and 1.5m when the macro selector switch is set to the Normal position (when macro photography is cancelled.) It cannot be turned to a distance closer than 1.5m.

PRECAUTIONS IN SHOOTING

The optical design for Di-II takes into consideration the various features of digital single reflex cameras. However, due to the configuration of the digital SLR cameras, even when the Autofocus accuracy is within specifications, the focal point may be a little forward or behind the optimum point when shooting with auto focus under some conditions.

The image circles of Di-II lenses are designed to match the digital SLR cameras using the image sensors equivalent to APS-C (approx. 15.5 x 23.2mm). Do not use Di-II lenses with such cameras as it may cause vignetting on the image.

A17 employs an internal focusing (IF) system. Because of the characteristics of this optical design, the angles of view at distances other than infinity are wider than that of the lenses applying an ordinary focusing system.

When the built-in flash on the camera is used, adverse photographic phenomena such as corner illumination, fall-off, or vignetting at the bottom part of the image may be observed, especially with wide angle ranges. This is due to the inherent limitation of the coverage of the built-in flash, and/or the relative position of the flash to the edge of the lens barrel which causes shadows on the image. It is strongly recommended to use a suitable separate flash unit provided by the camera manufacturer for all flash photography.

When using the lens in the telephoto focal range, please be careful with the camera shake. Effective way to avoid the camera shake is using an ISO setting of higher numbers. Using a tripod or monopod is also effective.

When set on AF mode, interfering with the focusing ring may cause serious damage to the lens mechanism.

Certain camera models may indicate the maximum and minimum aperture values of the lenses appropriate numbers. This is inherent to the design of the camera and not an indication of error.

When using a special filter such as a PL filter on the A16, use low-profile filters. The thick rim of a normal filter may cause vignetting.

TO ENSURE LONG-TERM SATISFACTION

Avoid touching the glass element surface. Use a photographic lens cloth or a blower to remove dust from the lens element surface. When not using the lens, always place a lens cap on it for protection.

Use a lens cleaning tissue or lint cloth with a drop of cleaning solution to remove fingerprints or dirt on the glass lens surface with a rotary motion from the center to the edges.

Use a silicon cloth to clean your lens barrel only.

Mildew is an enemy of your lens. Clean the lens after shooting near water or in any humid place. Store your lens in a clean, cool, dry place. When storing your lens in a lens case, store it with commercially available drying agents such as silica gel, and change the agent occasionally. If you find mildew on your lens, consult an authorized repair shop or nearby photographic store.

Do not touch the lens-camera interface contacts since dust, dirt and/or stains may cause a contact failure between the lens and camera.

When using your equipment in an environment where the temperature changes from one extreme to another, make sure to put your equipment temporarily in a case or a plastic bag for a length of time in order for the equipment to go through a gradual temperature, this will reduce potential equipment trouble.

Free Manuals Download Website

<http://myh66.com>

<http://usermanuals.us>

<http://www.somanuals.com>

<http://www.4manuals.cc>

<http://www.manual-lib.com>

<http://www.404manual.com>

<http://www.luxmanual.com>

<http://aubethermostatmanual.com>

Golf course search by state

<http://golfingnear.com>

Email search by domain

<http://emailbydomain.com>

Auto manuals search

<http://auto.somanuals.com>

TV manuals search

<http://tv.somanuals.com>