

# ***Tanaka***

---

## **Parts Catalog**

■

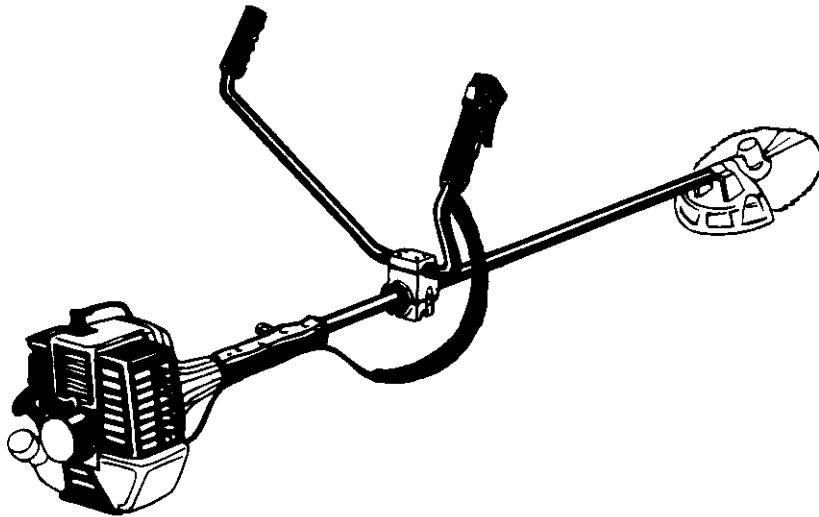

**Brush Cutter**

**Model: TBC-500**

# TBC-500

## OPTIONS AND ACCESSORIES

### NYLON LINE



- 746157 .105, Box, 50 ft.
- 746161 .105, 1/2 lb. Box, 110 ft
- 746162 .130, 1/2 lb. Box, 75ft.
- 746166 .105, 1 lb. Box, 235 ft.
- 746167 .130, 1 lb. Box, 150 ft.
- 746170 .105, 3 lb. spool, 705 ft.
- 746171 .130, 3 lb. spool, 450 ft.
- 746174 .105, 5 lb. spool, 1175 ft.
- 746175 .130, 5 lb. spool, 750 ft.

### SEMI-AUTO HEAD

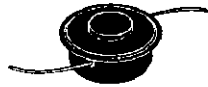

746153 PNH-180

#### Parts List

- |         |           |
|---------|-----------|
| ET-1201 | Body      |
| ET-1206 | Cap       |
| ET-1225 | Adapter   |
| ET-1205 | Spool     |
| ET-1207 | Eyelet    |
| ET-1208 | Spring    |
| ET-1209 | Bump Disk |

### ALUMINUM MANUAL HEAD



PCH-100  
(746180)

PCH-300  
(746190)

### PERFECT MIX® 2-Cycle Engine Oil

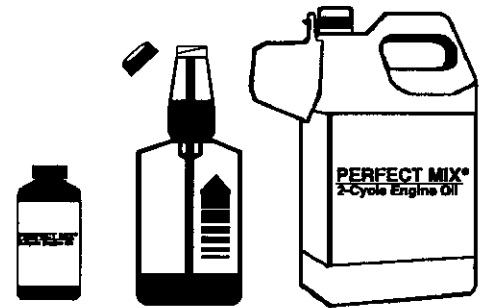

- 700109 2.8 oz. Bottle, 1 Gallon Size (24\*)
  - 700108 16 oz. Self-measuring Bottle (24\*)
  - 700110 1 Gallon Jug Commercial Size (6\*)
- \* Case Quantity

### SHOULDER STRAPS

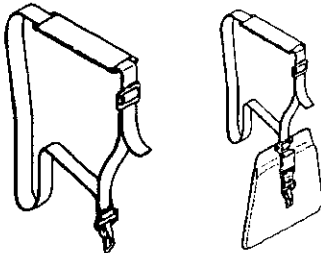

PSS-175

SS-250

### BLADES



- 746105 Weed Blade, 10"X4T
- 746106 Weed Blade, 10"X8T
- 746108 Saw Blade, 10"X80T
- 746192 Carbide Blade, 9"X36T

### BLADE SAFETY DISK

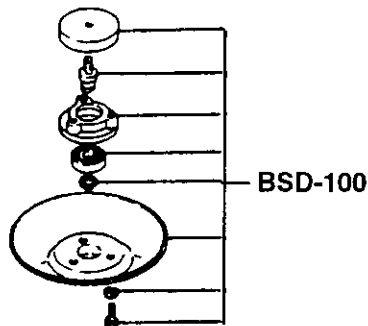

BSD-100

#### BSD-100 Parts List

- 603-33411-200 Cover, disk
- 604-33411-204 Bolt, disk fixing
- 602-33411-201 Metal, disk
- 999-66100-203 Bearing, ball
- 993-50015-002 Ring, stop
- 601-33411-201 Disk, safety
- 992-10060-012 Washer,s, 6mm
- 990-21060-151 Bolt, 6x15mm

### MANUALS / CATALOGS

- 00131 Owner's Manual
- 10992 Parts Catalog

### SPECIAL TOOLS

- |               |                    |               |                 |
|---------------|--------------------|---------------|-----------------|
| 006-29326-000 | Flywheel Remover   | 020-29371-140 | Coil gap guage  |
| 009-29326-000 | Piston Pin Remover | 001-29000-000 | Tachometer      |
| 015-29371-000 | Gear Shaft Remover | 070-2000W-500 | Pressure Tester |
| 016-29371-000 | Pinion Remover     | 070-2000W-501 | Carb. Tool Kit  |



# FIG.1 ENGINE

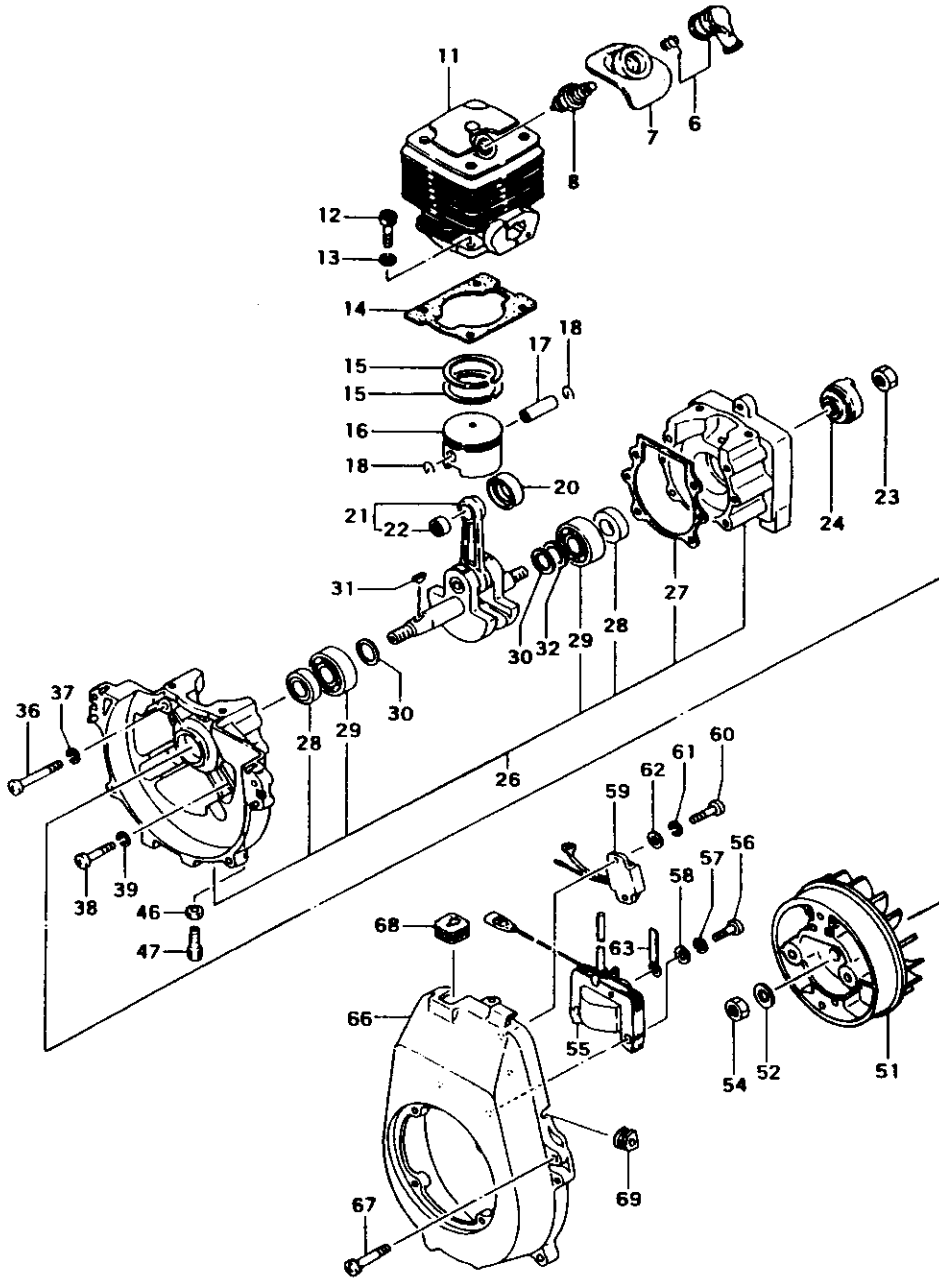

FIGURE 1

## TBC-500 PARTS LISTING

REF.	PART NO.	PART DESCRIPTION	Q	C	S	SERIAL NO.	REMARKS
6	157-11666-900	CAP,SPARK PLUG ASS'Y	1		C		
7	255-04200-200	COVER,SPARK PLUG,RUBBER	1		C		
8	018-02233-200	PLUG,SPARK	1		D		
11	002-04220-200	CYLINDER	1		D		
12	990-11050-181	SCREW,5X18	4		B		
13	992-10050-062	WASHER,S,5	4		D		
14	017-04220-21	GASKET,CYLINDER	1		C		
15	041-04090-210	RING,PISTON	2		C		
16	031-04090-201	PISTON	1		D		
17	037-04090-200	PIN,PISTON	1		D		
18	039-01000-200	CIRCLIP,PISTON PIN	2		D		
20	036-04090-20	COLLAR,PISTON PIN	2		C		
21	046-04220-80	CRANKSHAFT	1		D		
22	999-62101-480	BEARING,NEEDLE	1		D		
23	991-11100-013	NUT,10	1		C		
24	798-05015-200	PULLEY,STARTER	1		C		
26	072-04220-900	CRANKCASE,ASS'Y	1		D		Includes bearings, seals & gasket
27	090-04200-210	GASKET,CRANKCASE	1		D		
28	999-66152-511	SEAL,OIL,#VE15X25X7	2		A		
29	999-61620-200	BEARING,BALL,#6202	2		B		
30	070-02401-201	WASHER,CRANKSHAFT 15X22	2		D		
31	068-02000-200	KEY,WOODRUFF,3X13X5	1		D		
32	071-02007-200	SHIM,15.2X20X.05	1		D		
32	071-02007-210	SHIM,15.2X20X.10	1		D		Shims are "as needed" to obtain correct c/s side clearance.
32	071-02007-220	SHIM,15.2X20X.15	1		D		
32	071-11600-230	SHIM,16X21X.20	1		D		
32	071-11600-240	SHIM,16X21X.30	1		D		
36	990-11060-451	SCREW,6X45	2		D		
20	992-10060-012	WASHER,S,6	3		A		
38	990-11060-301	SCREW,6X30	2		D		
39	992-10060-012	WASHER,S,6	2		A		
46	991-01060-013	NUT,6	1		B		
47	894-01401-201	RECEIVER,OUTER	1		B		
51	155-20520-80	ROTOR,MAGNETO	1		D		
52	992-00100-011	WASHER,10	1		D		
54	991-11100-011	NUT,10	1		C		
55	167-20505-80	COIL,IGNITION	1		C		
56	990-11050-181	SCREW,5X18	3		B		

\* Indicates the part is included in a kit or assembly and is not available individually. Q=Quan. used C=Interchangeability S=Stocking code: A=Fast moving B=Med. fast C=Med. move D=Slow move E=N.L.A. F=Superceded or replaced by a new part

FIGURE 1 cont.

TBC-500 PARTS LISTING

REF.	PART NO.	PART DESCRIPTION	Q	C	S	SERIAL NO.	REMARKS
57	992-10050-012	WASHER,S,5	3		A		
58	992-00050-011	WASHER,SMALL,5	3		C		
59	159-20505-800	IGNITOR	1		C		
60	990-11050-141	SCREW,5X14	2		D		
61	992-10050-012	WASHER,S,5	2		A		
62	992-01050-011	WASHER,5	2		A		
63	198-05015-800	CLAMP,CORD	1		D		
66	112-04230-20	CASE,FAN	1		D		
67	994-14060-202	SCREW,6X20S	4		D		
68	203-0604A-202	GROMMET	1		C		
69	203-06000-200	GROMMET,PRIMARY CORD	1		C		

\* Indicates the part is included in a kit or assembly and is not available individually. Q=Quan. used C=Interchangeability S=Stocking code: A=Fast moving B=Med. fast C=Med. move D=Slow move E=N.L.A. F=Superceded or replaced by a new part

# FIG.2 ENGINE COMPONENTS

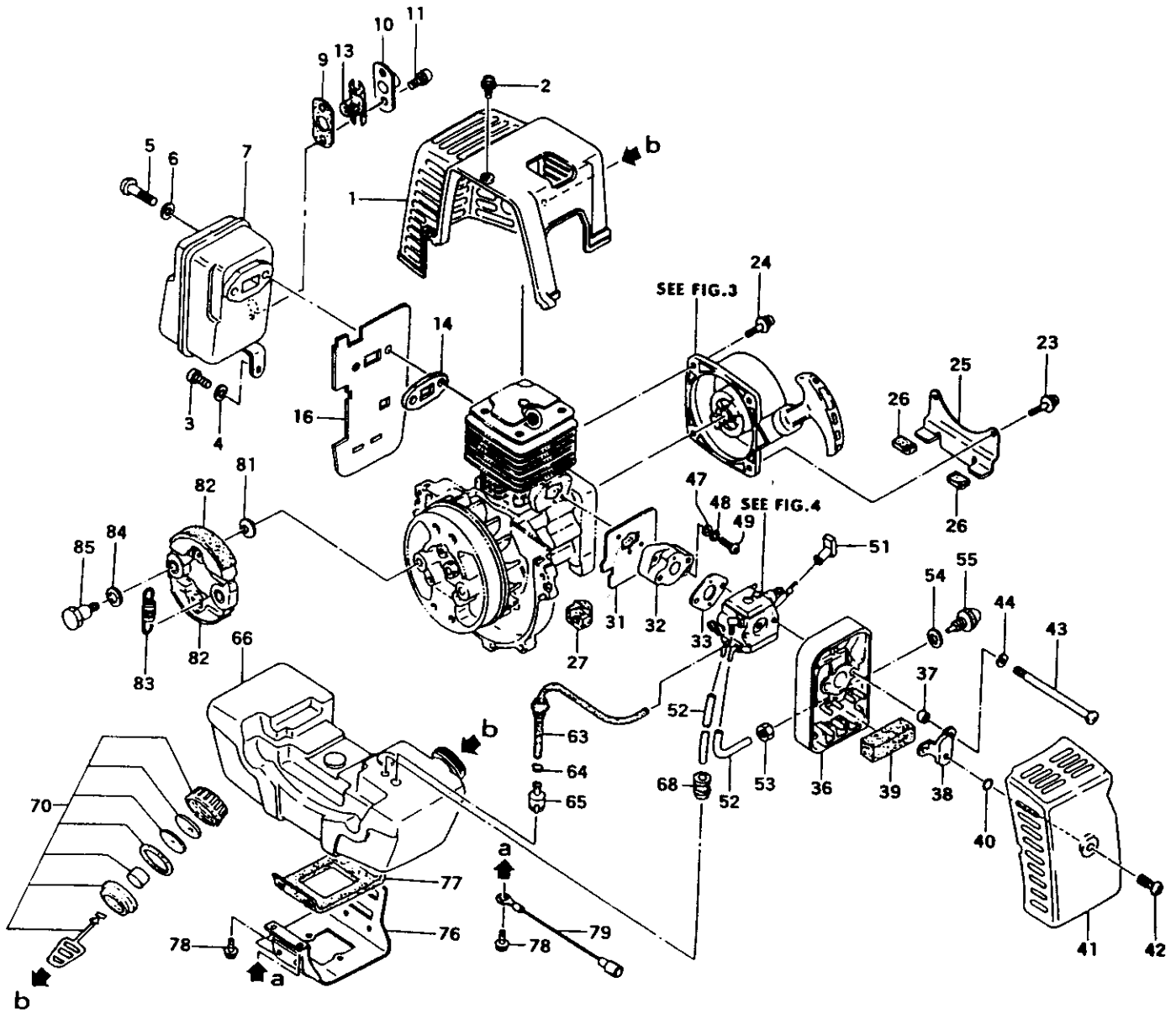

FIGURE 2

## TBC-500 PARTS LISTING

REF.	PART NO.	PART DESCRIPTION	Q	C	S	SERIAL NO.	REMARKS
1	738-04220-20	PROTECTOR,MUFFLER	1		C		
2	994-15050-122	SCREW,5X12/PS	1		C		
3	990-11050-121	SCREW,5X12	1		A		
4	992-01050-011	WASHER,5	1		A		
5	990-53060-653	SCREW,HEX,6X65	2		D		
6	992-01060-011	WASHER,6	2		A		
7	706-04230-80	MUFFLER	1		D		
9	751-04200-201	GASKET,MUFFLER	1		C		
10	721-0097A-801	PIPE,TAIL	1		D		
11	994-14040-081	SCREW,4X8	2		D		
13	732-0631A-200	ARRESTER,SPARK	1		C		
14	737-04230-200	GASKET,MUFFLER	1		D		
16	133-04230-20	SHIELD,HEAT	1		C		
23	994-15050-182	SCREW,5X18/PS	2		C		
24	994-15050-252	SCREW,PS,5X25	2		C		
25	653-04200-200	BRACKET,TANK	1		D		
26	655-06100-200	CUSHION,TANK	2		A		
27	655-04200-200	CUSHION,FUEL TANK	2		C		
31	403-04220-21	GASKET,INTAKE	1		C		
32	404-04220-81	INSULATOR,CARBURETOR	1		C		
33	402-11650-200	GASKET,CARBURETOR	1		A		
36	423-04201-200	BODY,CLEANER	1		C		
37	659-00801-200	COLLAR,TANK HOLDING METAL	2		C		
38	476-04050-200	BOARD,CHECK,BLOW OVER	1		C		
39	446-04201-200	ELEMENT,CLEANER	1		B		
40	999-67003-000	O-RING,P3	1		C		
41	424-04200-210	CAP,CLEANER	1		C		
42	380-0631A-200	BOLT,CLEANER COVER	1		B		
43	990-11050-601	SCREW,5X60	2		C		
44	992-10050-012	WASHER,S,5	2		A		
47	992-00050-011	WASHER,SMALL,5	2		C		
48	992-10050-012	WASHER,S,5	2		A		
49	990-11050-241	SCREW,5X24	2		D		
51	495-04200-200	LEVER,CHOKE	1		A		
52	700-02504-090	PIPE,FUEL	2		D		
53	991-11100-011	NUT,10	1		C		
54	992-20100-010	WASHER,10 INNER TOOTHED	1		D		
55	422-25030-800	PUMP,PRIMING	1		C		

\* Indicates the part is included in a kit or assembly and is not available individually. Q=Quan. used C=Interchangeability S=Stocking code: A=Fast moving B=Med. fast C=Med. move D=Slow move E=N.L.A. F=Superceded or replaced by a new part

## TBC-500 PARTS LISTING

REF.	PART NO.	PART DESCRIPTION	Q	C	S	SERIAL NO.	REMARKS
63	223-01251-901	PIPE,FUEL,3X5X230	1		C		
64	680-00731-201	CLIP	1		B		
65	675-01630-900	FILTER,FUEL	1		A		
66	591-04220-200	TANK,FUEL	1		D		
68	534-32710-200	GROMMET, FUEL PIPE	1		C		
70	595-0423Q-90	CAP,TANK	1		A		
76	603-04201-200	BAND,HOLDING,TANK	1		C		
77	652-04201-200	CUSHION	1		C		
78	994-15050-162	SCREW,5X16/PS	2		C		
79	179-04201-800	CORD,STOP	1		D		
81	359-10112-203	WASHER,CLUTCH B	2		A		
82	290-04200-80	SHOE,CLUTCH	2		B		
83	342-04200-200	SPRING,CLUTCH	1		B		
84	358-10112-201	WASHER,CLUTCH	1		A		
85	357-04201-200	BOLT,CLUTCH STEP	2		B		

\* Indicates the part is included in a kit or assembly and is not available individually. Q=Quan. used C=Interchangeability S=Stocking code: A-Fast moving B=Med. fast C=Med. move D=Slow move E=N.L.A. F=Superseded or replaced by a new part



# FIG.3 RECOIL STARTER

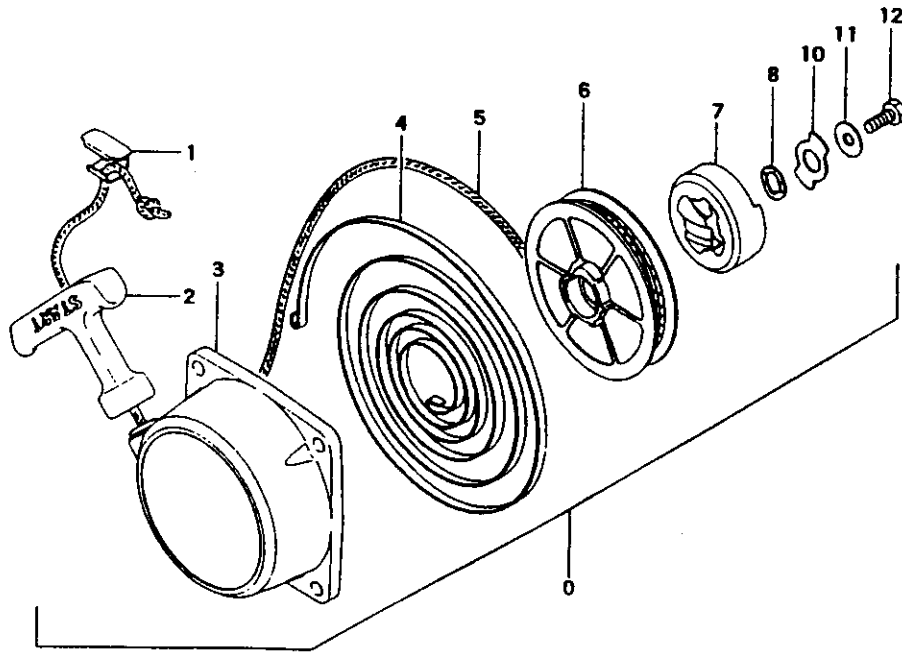
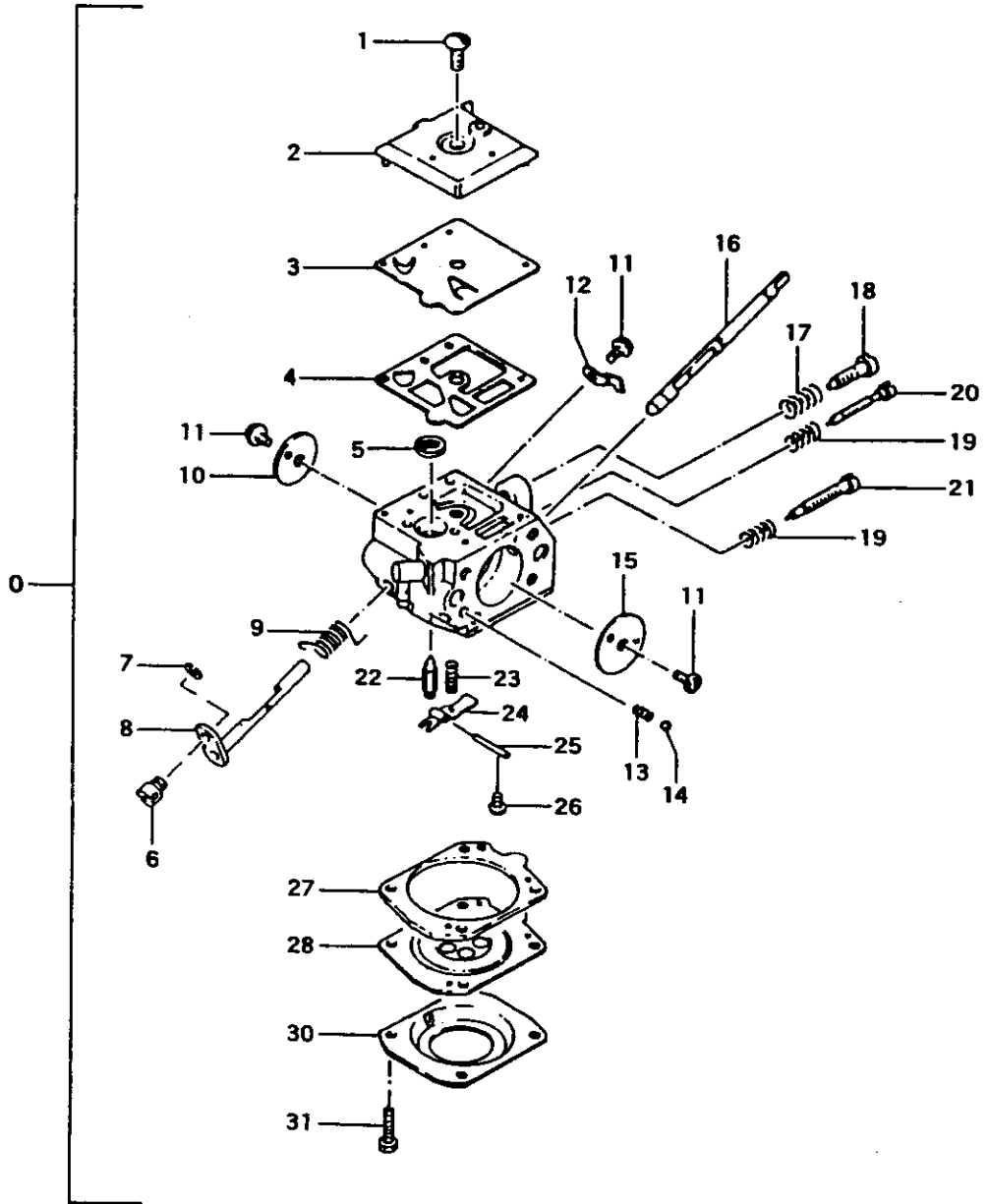

FIGURE 3

## TBC-500 PARTS LISTING

REF.	PART NO.	PART DESCRIPTION	Q	C	S	SERIAL NO	REMARKS
0	762-05015-91	STARTER, RECOIL ASSY	1		B		
1	815-06000-200	METAL, STARTER HANDLE	1		D		
2	785-04220-20	HANDLE, STARTER	1		C		
3	772-05015-800	BODY, RECOIL STARTER	1		C		
4	779-06000-200	SPRING, RECOIL	1		B		
5	783-05004-200	ROPE, STARTER, 3.8X1070	1		D		
6	769-05015-200	REEL, STARTER ROPE	1		C		
7	788-05015-200	PAWL, STARTER	1		F		
8	801-05015-200	WASHER, STARTER PULLEY	1		B		
10	837-05015-200	PLATE, FRICTION	1		F		
11	822-05015-200	SHIM, STARTER PULLEY	1		F		
12	839-05015-20	BOLT, SET	1		C		

# FIG.4 CARBURETOR



**FIGURE 4**

**TBC-500 PARTS LISTING**

REF.	PART NO.	PART DESCRIPTION	Q	C	S	SERIAL NO.	REMARKS
0	455-25055-900	CARBURETOR,ASS'Y	1		D		
1	514-25001-200	SCREW,SET	1		D		
2	575-25012-200	BODY,PUMP	1		D		
3	~~~	(1)(2)GASKET,PUMP	1		C		
4	~~~	(1)(2)DIAPHRAGM,PUMP	1		C		(1) Carb. Repair Kit
5	~~~	(1)SCREEN,INLET	1		C		650-25032-910
6	539-25101-200	SWIVEL	1		D		(2) Carb. Gasket/Dia. Kit
7	489-25008-200	RING,STOP	1		C		652-25032-910
8	464-25032-800	SHAFT,THROTTLE	1		D		
9	486-25032-200	SPRING,THROTTLE	1		C		
10	488-25001-200	VALVE,THROTTLE	1		C		
11	467-25003-200	SCREW,SHUTTER	3		C		
12	559-25012-200	PLATE,STOP	1		D		
13	496-25032-200	SPRING,CHOKE	1		C		
14	567-25032-200	BALL,STEEL	1		C		
15	493-25032-200	VALVE,CHOKE	1		C		
16	492-25032-200	SHAFT,CHOKE	1		C		
17	463-25012-200	SPRING,IDLE ADJUST	1		D		
18	462-25006-200	SCREW,IDLE ADJUST	1		D		
19	623-25054-200	SPRING,ADJUST	2		D		
20	461-25032-200	SCREW,LOW ADJUST	1		D		
21	460-25032-200	SCREW,HIGH ADJUST	1		D		
22	~~~	(1)VALVE,NEEDLE	1		C		
23	477-25051-200	SPRING,VALVE	1		D		
24	~~~	(1)LEVER,CONTROL	1		D		
25	~~~	(1)PIN,FLOAT	1		D		
26	546-25001-200	SCREW,SET,HINGE PIN	1		D		
27	~~~	(1)(2)GASKET,DIAPHRAGM	1		C		
28	~~~	(1)(2)DIAPHRAGM,METERING	1		C		
30	476-25032-200	COVER,DIAPHRAGM	1		D		
31	548-25016-200	SCREW,SET	4		D		

(1) (2) Indicates the part is included in a kit or assembly and is not available individually.  
 Q=Quan. used C=Interchangeability S=Stocking code: A=Fast moving B=Med. fast C=Med. move  
 D=Slow move E=N.L.A. F=Superseded or replaced by a new part

# FIG.5 CLUTCH CASE

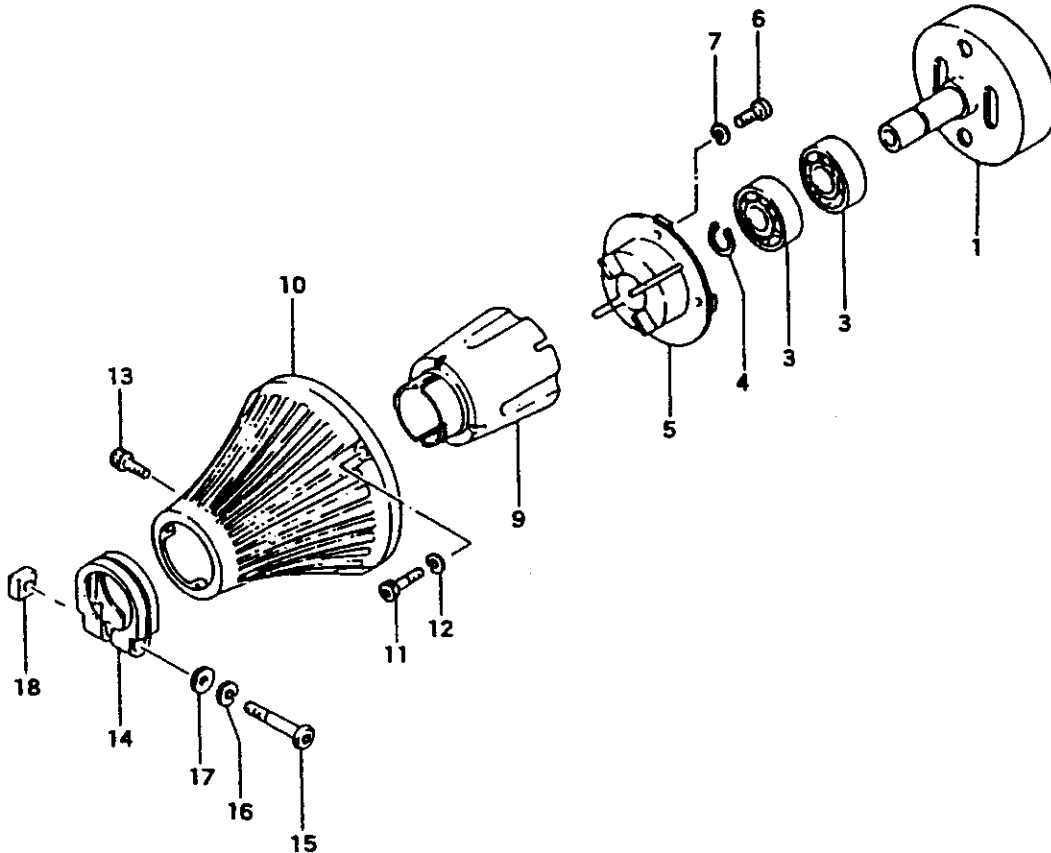

FIGURE 5

## TBC-500 PARTS LISTING

REF.	PART NO.	PART DESCRIPTION	Q	C	S	SERIAL NO.	REMARKS
1	289-04205-801	SHAFT,CLUTCH	1		C		
3	999-61620-202	BEARING,BALL,#6202Z	2		C		
4	993-50015-002	RING,STOP,C-15 EX	1		C		
5	347-04201-20	FLANGE,CLUTCH	1		C		
6	990-11050-161	SCREW,5X16	4		B		
7	992-10050-012	WASHER,S,5	4		A		
9	599-04201-80	CUSHION	1		C		
10	331-04201-200	CASE,CLUTCH	1		D		
11	990-51050-123	BOLT,HEX,5X12	4		C		
12	992-10050-062	WASHER,S,5	4		D		
13	990-51050-103	BOLT,HEX.HOLE,5X10	1		C		
14	282-04201-200	HOLDER,PIPE	1		D		
15	990-53060-453	BOLT,HEX,6X45	1		C		
16	992-10060-062	WASHER,S,6	1		A		
17	992-01060-061	WASHER,6	1		D		
18	991-91060-061	NUT,SQUARE,6	1		C		

# FIG.6 HANDLE(A)

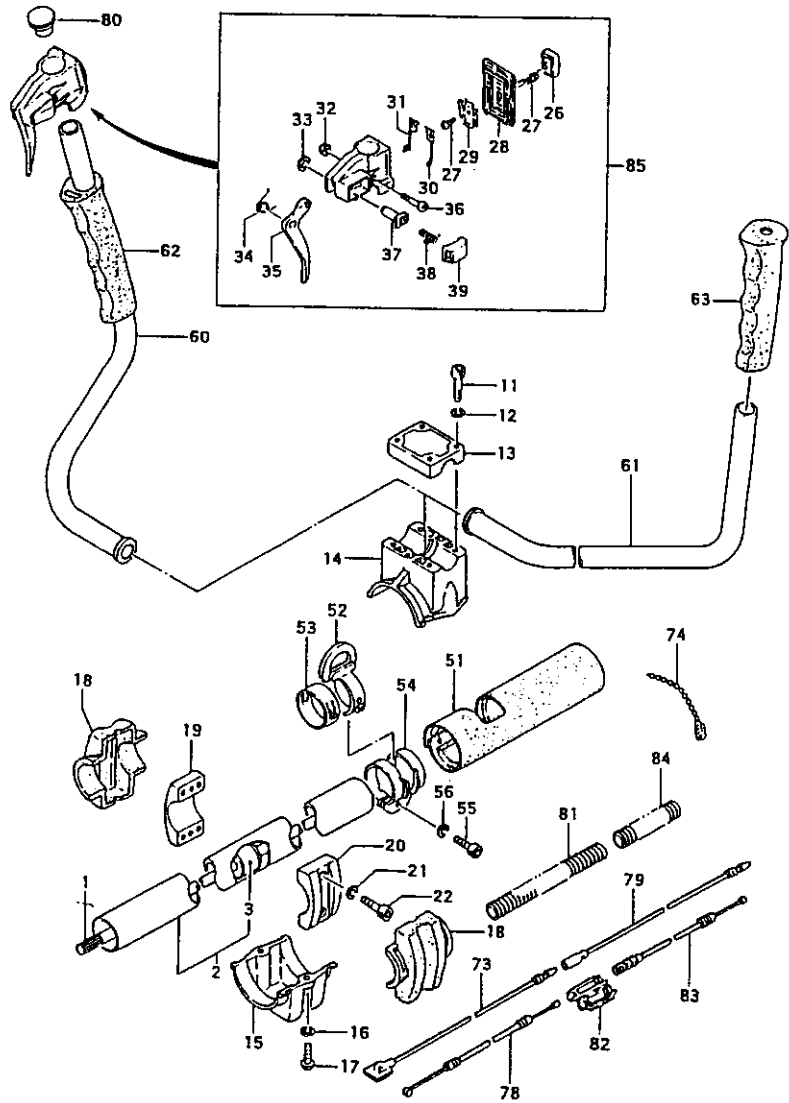
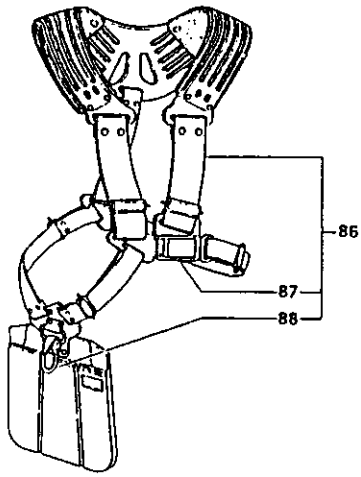

FIGURE 6 A

## TBC-500 PARTS LISTING

REF.	PART NO.	PART DESCRIPTION	Q	C	S	SERIAL NO.	REMARKS
1	343-37121-20	SHAFT,DRIVE	1		D		
2	341-37101-80	PIPE,DRIVE SHAFT	1		C		
3	347-37100-90	BUSHING ASS'Y	5		D		
11	990-51050-163	BOLT,HEX,5X16	4		C		
12	992-10050-062	WASHER,S,5	4		D		
13	506-37110-203	BRACKET,HANDLE,A	1		D		
14	507-37110-200	BRACKET,HANDLE B	1		D		
15	508-37100-200	BRACKET	1		D		
16	992-10060-062	WASHER,S,6	2		A		
17	990-53060-203	BOLT,HEX,6X20	2		C		
18	319-37100-200	CUSHION	2		D		
19	449-37100-202	LOCK,SHAFT B	1		D		
20	448-37100-202	LOCK,SHAFT A	1		D		
21	992-10050-062	WASHER,S,5	2		D		
22	990-51050-183	BOLT,HEX,5X18	2		D		
26	162-37101-200	SWITCH,STOP	1		C		
27	993-42030-081	SCREW, TAPPING, 3X8	3		D		
28	259-37101-200	BASE,STOP SWITCH	1		C		
29	262-37101-200	SPRING,STOP SWITCH	1		D		
30	177-37101-200	TERMINAL,EARTH B	1		C		
31	176-37101-200	TERMINAL,EARTH A	1		D		
32	991-86050-000	NUT,LOCK,5	1		D		
33	993-55060-001	RING,STOP,6	1		D		
34	832-37101-200	SPRING,RETURN	1		C		
35	880-37101-200	ARM,THROTTLE	1		B		
36	994-31050-251	SCREW,S.,5X25	1		C		
37	853-37101-200	SHAFT,LOCK BUTTON	1		D		
38	958-37101-200	SPRING,LOCK,BUTTON	1		D		
39	956-37101-200	BUTTON,LOCK	1		D		
51	336-37100-800	PAD	1		C		
52	335-37100-201	BRACKET,STRAP	1		D		
53	334-37101-200	COLLAR,LIFTING METAL	1		D		
54	338-37101-800	STOPPER,STRAP SUPPORT	1		D		
55	990-51050-153	BOLT,HEX.HOLE,5X15	1		C		
56	992-10050-062	WASHER,S,5	1		D		
60	501-33674-200	HANDLE,RIGHT	1		D		
61	502-33674-21	HANDLE,LEFT	1		C		
62	503-37113-200	GRIP,HANDLE R	1		D		

\* Indicates the part is included in a kit or assembly and is not available individually. Q=Quan. used C=Interchangeability S=Stocking code: A=Fast moving B=Med. fast C=Med. move D=Slow move E=N.L.A. F=Superceded or replaced by a new part

## TBC-500 PARTS LISTING

REF.	PART NO.	PART DESCRIPTION	Q	C	S	SERIAL NO.	REMARKS
63	165-33130-200	GRIP,HANDLE A	1		C		
73	178-37100-800	CORD,STOP	2		B		
74	460-33111-900	CLAMP	1		B		
78	885-37110-800	WIRE,THROTTLE	1		B		
79	178-04201-800	CORD,STOP	1		D		
80	499-37100-200	GROMMET,PIPE	1		C		
81	164-13038-01	TUBE,PROTECTION	1		C		
82	888-04030-200	CASE,CONNECTOR	1		A		
83	885-04207-800	WIRE,THROTTLE	1		C		
84	164-13018-00	TUBE,PROTECTION	1		D		
85	870-37101-900	LEVER,THROTTLE ASS'Y	1		B		
86	SS-400	STRAP,SHOULDER	1		B		
87	738-37113-900	BUCKLE,SS-400,ASS'Y	1		D		
88	748-37113-800	HOOK,SS-400	1		D		

\* Indicates the part is included in a kit or assembly and is not available individually. Q=Quantity used C=Interchangeability S=Stocking code: A=Fast moving B=Med. fast C=Med. move D=Slow move E=N.L.A. F=Superseded or replaced by a new part

FIG.6 HANDLE (B)

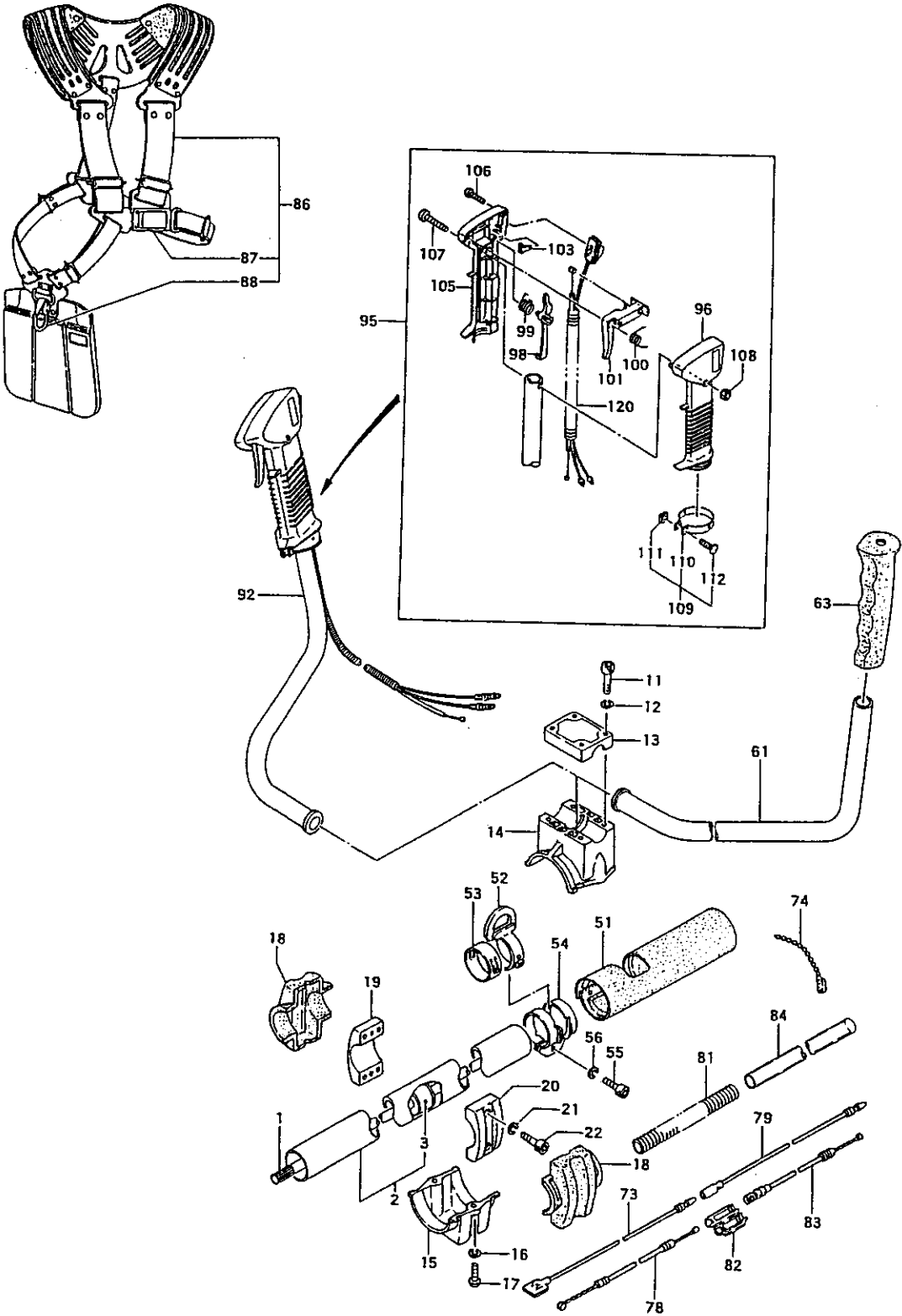



FIGURE 6 B

## TBC-500 PARTS LISTING

REF.	PART NO.	PART DESCRIPTION	Q	C	S	SERIAL NO.	REMARKS
1	343-37121-20	SHAFT,DRIVE	1		D		
2	341-37101-80	PIPE,DRIVE SHAFT	1		C		
3	347-37100-90	BUSHING ASS'Y	1		D		
11	990-51050-163	BOLT,HEX,5X16	4		C		
12	992-10050-062	WASHER,S,5	4		D		
13	506-37110-203	BRACKET,HANDLE,A	1		D		
14	507-37110-200	BRACKET,HANDLE B	1		D		
15	508-37100-200	BRACKET	1		D		
16	992-10060-062	WASHER,S,6	2		A		
17	990-53060-203	BOLT,HEX,6X20	2		C		
18	319-37100-200	CUSHION	2		D		
19	449-37100-202	LOCK,SHAFT B	1		D		
20	448-37100-202	LOCK,SHAFT A	1		D		
21	992-10050-062	WASHER,S,5	2		D		
22	990-51050-183	BOLT,HEX,5X18	2		D		
51	336-37100-800	PAD	1		C		
52	335-37100-201	BRACKET,STRAP	1		D		
53	334-37101-200	COLLAR,LIFTING METAL	1		D		
54	338-37101-800	STOPPER,STRAP SUPPORT	1		D		
55	990-51050-153	BOLT,HEX.HOLE,5X15	1		C		
56	992-10050-062	WASHER,S,5	1		D		
61	502-33674-21	HANDLE,LEFT	1		C		
63	165-33130-200	GRIP,HANDLE A	1		C		
73	178-37100-800	CORD,STOP	1		B		Used on handle "A" only
74	460-33111-900	CLAMP	1		B		
78	885-37110-800	WIRE,THROTTLE	1		B		Used on handle "A" only
79	178-04201-800	CORD,STOP	1		D		Used on handle "A" only
81	164-13038-01	TUBE,PROTECTION	1		C		Used on handle "A" only
82	888-04030-200	CASE,CONNECTOR	1		A		Used on handle "A" only
83	885-04207-800	WIRE,THROTTLE	1		C		Used on handle "A" only
84	164-13018-00	TUBE,PROTECTION	1		D		Used on handle "A" only
86	SS-400	STRAP,SHOULDER	1		B		
87	738-37113-900	BUCKLE,SS-400,ASS'Y	1		D		
88	748-37113-800	HOOK,SS-400	1		D		
92	501-37155-20	HANDLE,RIGHT	1		D		
95	870-37466-90	LEVER,THROTTLE ASS'Y	1		D		
96	875-37466-20	BODY,THROTTLE	1		D		
98	253-37466-20	LEVER,SAFETY	1		D		

\* Indicates the part is included in a kit or assembly and is not available individually. Q=Quan. used  
 C=Interchangeability S=Stocking code: A=Fast moving B=Med. fast C=Med. move D=Slow move  
 E=N.L.A. F=Superceded or replaced by a new part

FIGURE 6 B cont.

TBC-500 PARTS LISTING

REF.	PART NO.	PART DESCRIPTION	Q	C	S	SERIAL NO.	REMARKS
99	958-37411-20	SPRING,LOCK BUTTON	1		C		
100	832-37411-20	SPRING,RETURN	1		C		
101	880-37466-20	ARM,THROTTLE	1		D		
102	956-37411-20	BUTTON,LOCK	1		D		
105	884-37466-20	BODY,THROTTLE B	1		D		
106	993-42040-182	SCREW,TAPPING 4X18	1		C		
107	990-11050-354	SCREW,5X35	1		D		
108	991-01050-043	NUT,5	1		C		
109	889-37411-90	BAND ASS'Y,THROTTLE LEVER	1		D		
110	889-37411-20	BAND,THROTTLE LEVER	1		D		
111	991-91060-061	NUT,SQUARE,6	1		C		
112	994-31060-203	SCREW,6X20	1		D		
120	887-37466-80	WIRE,THROTTLE	1		C		Includes stop cords and prot. tube

\* Indicates the part is included in a kit or assembly and is not available individually. Q=Quan. used  
 C=Interchangeability S=Stocking code: A-Fast moving B=Med. fast C=Med. move D=Slow move  
 E=N.L.A. F=Superceded or replaced by a new part

# FIG.7 GEAR CASE

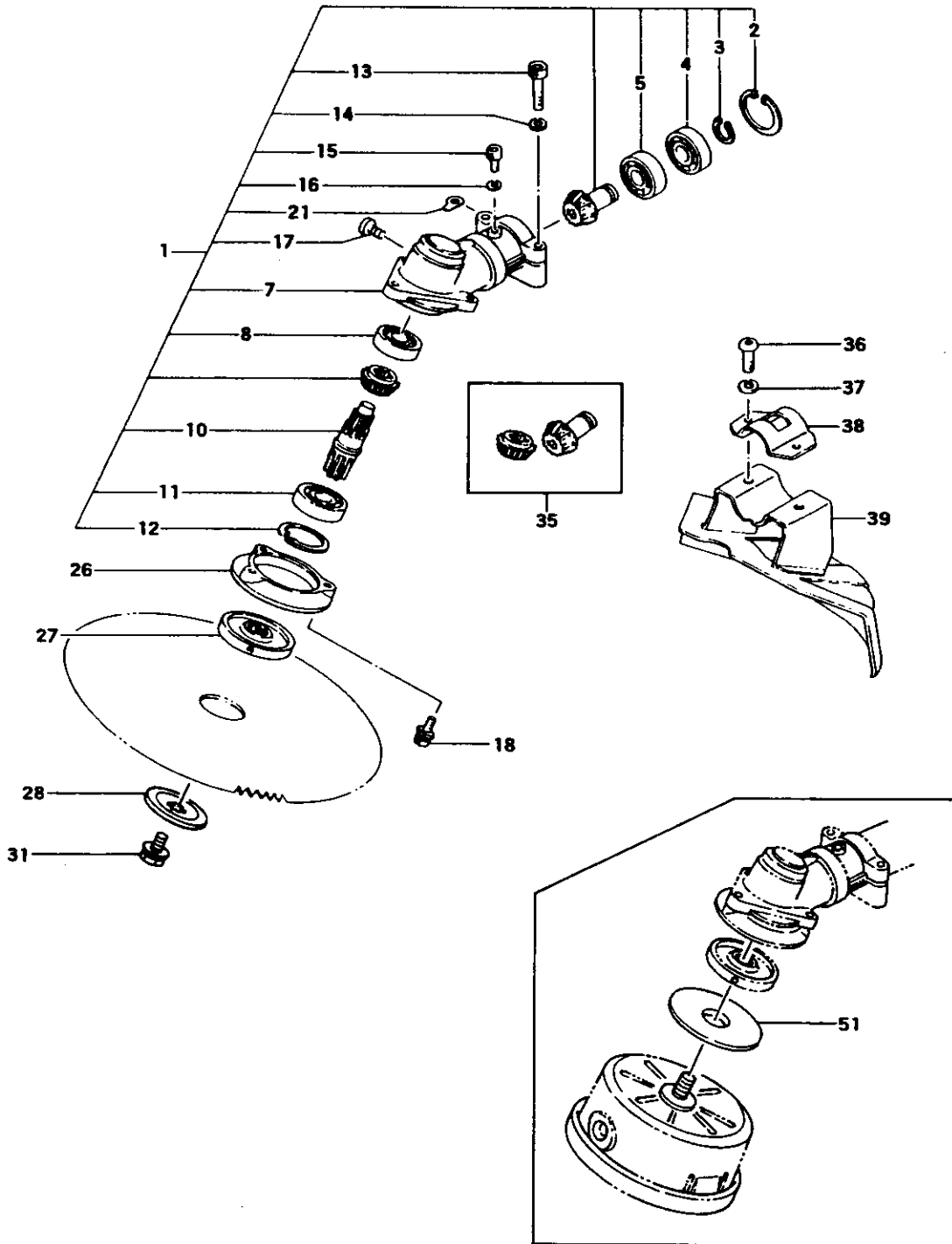

FIGURE 7

## TBC-500 PARTS LISTING

REF.	PART NO.	PART DESCRIPTION	Q	C	S	SERIAL NO.	REMARKS
1	300-37100-91	CASE,GEAR,ASS'Y	1		C	-P005785	
1	300-37100-93	CASE,GEAR ASS'Y	1		D	P005786~	
2	993-51028-002	RING,STOP,IN,C-28	1		C		
3	993-50012-002	RING,STOP,C-12 EX	1		A		
4	999-61600-102	BEARING,BALL,#6001Z	1		B		
5	999-61600-100	BEARING,BALL,#6001	1		B		
7	300-37100-21	CASE,GEAR	1		C	-P005785	
7	300-37100-22	CASE,GEAR	1		D	P005786~	
8	999-61600-000	BEARING,BALL,#6000	1		C		
10	304-37100-20	SHAFT,GEAR	1		D	~P052020	
10	304-37100-21	SHAFT,GEAR	1		C	P052021~	
11	999-61620-303	BEARING,BALL,#6203D	1		C		
12	993-51040-002	RING,STOP,C40	1		C		
13	990-51050-253	BOLT,HEX,5X25	2		B		
14	992-10050-062	WASHER,S,5	1		D		
15	990-51050-123	BOLT,HEX,5X12	1		C		
16	992-10050-062	WASHER,S,5	1		D		
17	990-14080-104	SCREW,8X10	1		A		
18	994-16050-162	SCREW,5X16/WS	3		D		
21	324-37110-200	WASHER,GEAR CASE	2		D		
26	307-37100-800	COVER, PROTECTION	1		C	-P005785	
26	307-37100-81	COVER, PROTECTION	1		C	P005786~	
27	310-37100-20	HOLDER,CUTTER	1		B	~P005785	
27	310-37100-21	HOLDER,CUTTER	1		C	P005786~	
28	311-33386-20	CAP,CUTTER HOLDER	1		C		
31	312-33386-20	BOLT, FIXING, L.H.	1		C		
35	301-37100-00	SET,GEAR/PINION	1		D		
36	990-53060-153	BOLT,HEX,6X15	2		B		
37	992-10060-062	WASHER,S,6	2		A		
38	442-37100-200	BRACKET,SAFETY GUARD	1		C		
39	441-37100-80	GUARD,SAFETY	1		C		
51	320-33670-200	SPACER	1		D		

\* Indicates the part is included in a kit or assembly and is not available individually. Q=Quan. used C=Interchangeability S=Stocking code: A=Fast moving B=Med. fast C=Med. move D=Slow move E=N.L.A. F=Superseded or replaced by a new part

# FIG.8 TOOLS & NYLON HEAD

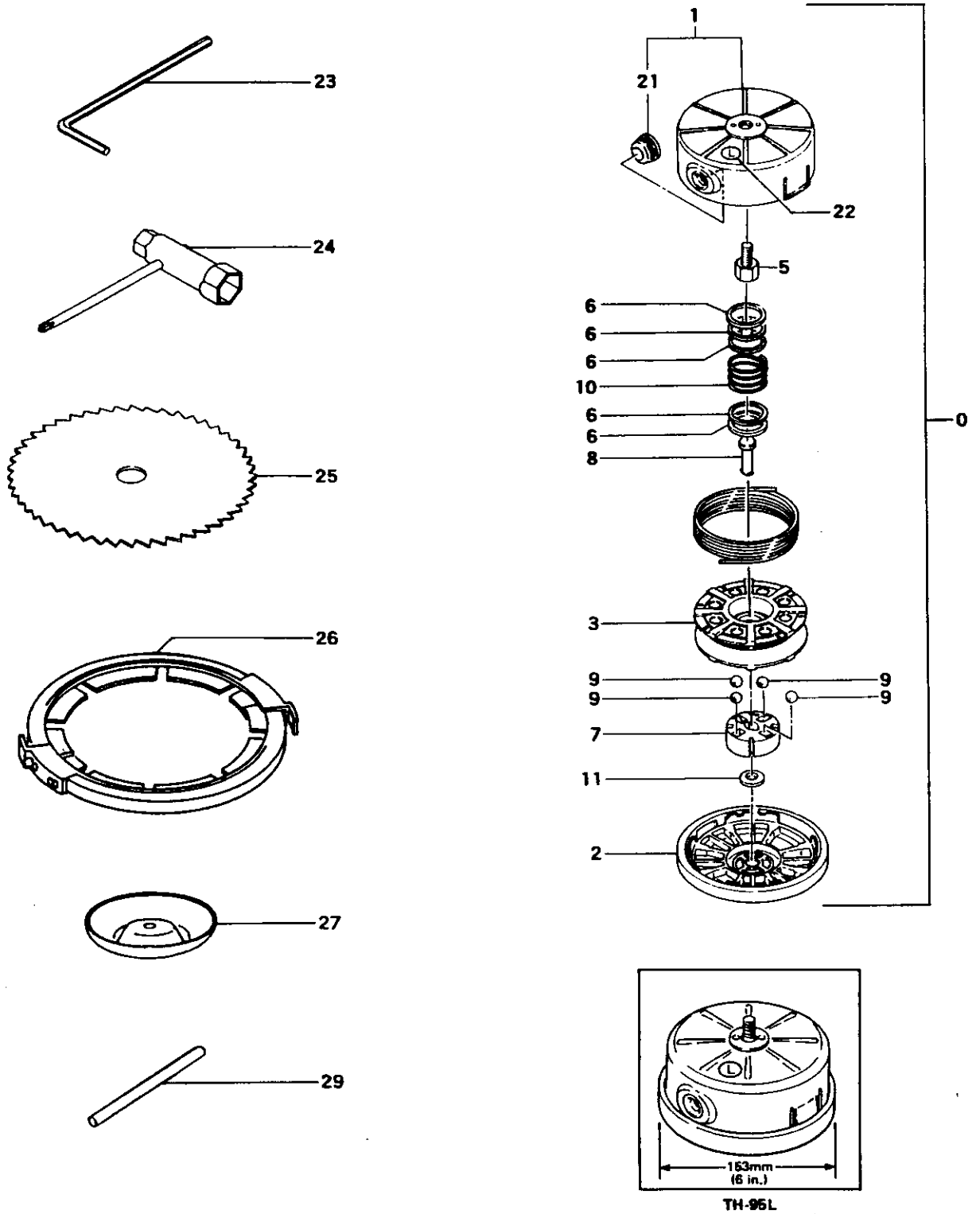

**FIGURE 8**

**TBC-500 PARTS LISTING**

REF.	PART NO.	PART DESCRIPTION	Q	C	S	SERIAL NO.	REMARKS
0	783-33670-93	IR487/AUTO HEAD (L)	1		B		
1	786-33670-92	BODY,CUTTING	1		C		
2	789-33670-23	CAP,BODY	1		B		
3	787-33670-210	REEL,(L)	1		C		
5	314-33670-20	BOLT,8X1.25 LH GOLD	1		A		
6	792-33004-200	WASHER,REEL	5		A		
7	790-33004-200	SLIDER,REEL	1		A		
8	791-33004-200	HOOK,REEL SLIDER	1		A		
9	673-35600-20	BALL,STEEL	4		B		
10	793-33910-20	SPRING,REEL	1		A		
11	358-02103-200	WASHER,CLUTCH A	1		A		
21	788-33670-21	EYELET	2		C		
23	813-20000-200	WRENCH,HEX,4	1		D		
24	826-20000-200	SPANNER,BOX,17X19	1		D		
25	746108	BLADE,10X80,1R489,(PSB-180)	1		A		
26	BP-100	PROTECTOR,BLADE,9/10"	2		E		
27	308-33410-200	COVER,PROTECTION,B	1		D		
29	752-37100-200	BAR,LOCKING	1		D		
35	948-39907-200	BAG,TOOL	1		D		

\* Indicates the part is included in a kit or assembly and is not available individually. Q=Quan. used C=Interchangeability S=Stocking code: A-Fast moving B=Med. fast C=Med. move D=Slow move E=N.L.A. F=Superceded or replaced by a new part

# FIG.9 MARKS

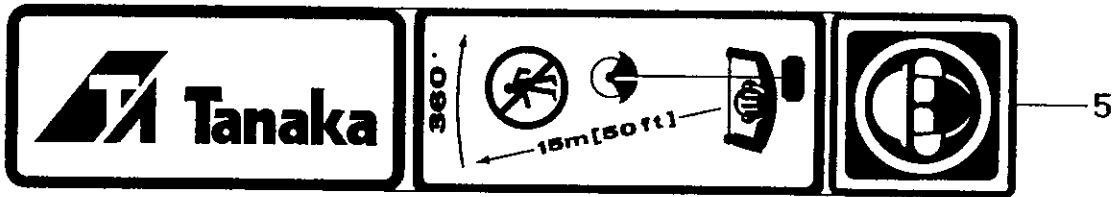
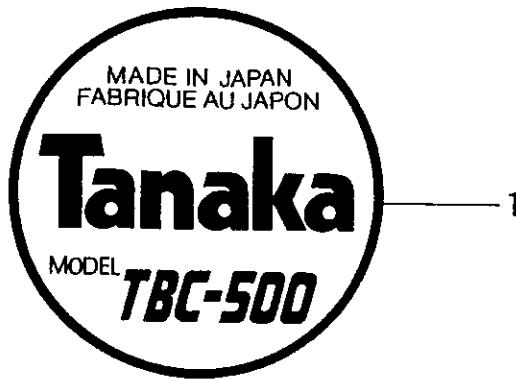

FIGURE 9

## TBC-500 PARTS LISTING

REF.	PART NO.	PART DESCRIPTION	Q	C	S	SERIAL NO.	REMARKS
1	906-04220-20	DECAL	1		D		
4	923-37400-200	DECAL,LEVEL	1		D		
5	919-37719-20	DECAL	1		D		

## Free Manuals Download Website

<http://myh66.com>

<http://usermanuals.us>

<http://www.somanuals.com>

<http://www.4manuals.cc>

<http://www.manual-lib.com>

<http://www.404manual.com>

<http://www.luxmanual.com>

<http://aubethermostatmanual.com>

Golf course search by state

<http://golfingnear.com>

Email search by domain

<http://emailbydomain.com>

Auto manuals search

<http://auto.somanuals.com>

TV manuals search

<http://tv.somanuals.com>