

Tanaka

Parts Catalog

Chain Saw

Model: ECS-290

Units Prior To Serial No. J 138950

FIG.1 ENGINE

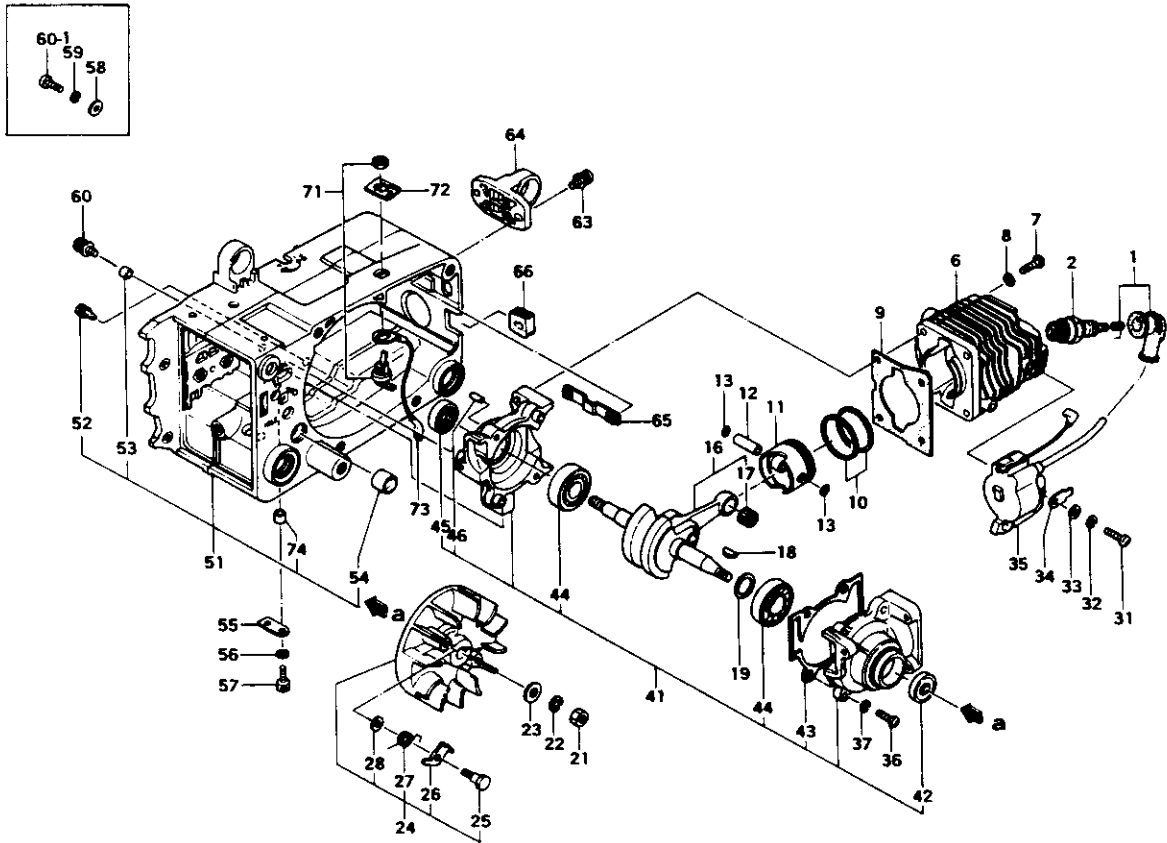

REF. NBR	PART NBR	PART NAME	QTY	SERIAL NBR	REMARKS
1-001	157-04200-900	SPARK PLUG CAP ASS'Y	1	-F131000	
1-001	157-11866-900	SPARK PLUG CAP ASS'Y	1	P F131001-	
1-002	018-00546-200	SPARK PLUG BMR6A	1	-F131000	
1-002	018-01805-200	SPARK PLUG CJ8	1	P F131001-	
1-006	002-01700-200	CYLINDER	1		
1-007	990-11050-161	SCREW 5X16	4		
1-008	992-10050-012	S.WASHER 5	4		
1-009	017-01700-200	CYLINDER GASKET	1		
1-010	041-01700-200	PISTON RING	2		
1-011	031-01700-200	PISTON	1		
1-012	037-01700-200	PISTON PIN	1		
1-013	039-00000-201	PISTON PIN CIRCLIP	2		
1-016	046-01700-800	CRANK SHAFT COMP.	1	R -F131000	
1-016	046-01700-801	CRANK SHAFT COMP.	1	F131001-	
1-017	999-62091-325	NEEDLE BEARING F-910	1		
1-018	088-10100-200	WOOD-RUFF KEY 3X13X4.5	1		
1-019	071-02007-200	CRANK SHAFT SHIM 0.05	V		
1-019	071-02007-210	CRANK SHAFT SHIM 0.10	V		
1-019	071-02007-220	CRANK SHAFT SHIM 0.15	V		
1-019	071-02007-230	CRANK SHAFT SHIM 0.20	V		
1-021	066-00000-200	FLYWHEEL NUT 12	1		
1-022	992-10070-012	S.WASHER 7	1		
1-023	992-01070-011	WASHER 7	1		
1-024	155-20507-900	MAGNETO ROTOR ASS'Y	1		
1-025	793-10200-201	STEP BOLT	2	-J075960	
1-025	793-10200-202	STEP BOLT	2	P J075961-	
1-026	788-01700-200	STARTER PAWL	2		
1-027	790-01700-200	STARTER PAWL SPRING	2		
1-028	182-01700-200	SPECIAL WASHER	2		
1-031	990-11040-181	SCREW 4X18	2		
1-032	992-10040-012	S.WASHER 4	2		
1-033	992-00040-011	SMALL WASHER 4	2		
1-034	205-01700-200	TAB	1		
1-035	167-20507-800	IGNITION COIL COMP.	1		
1-036	990-11050-251	SCREW 5X25	4		
1-037	992-10050-012	S.WASHER 5	4		
1-041	072-01700-910	CRANK CASE ASS'Y	1		
1-042	999-66122-200	OIL SEAL 12227	1		
1-043	090-01700-200	CRANK CASE GASKET	1		
1-044	999-61620-200	BALL BEARING #6202. 35MM/OD	2		
1-045	999-66152-500	OIL SEAL 15257	1		
1-046	999-05250-980	NEEDLE ROLLER 2.5X9.8	1		
1-051	560-32710-910	ENGINE CASE ASS'Y	1		
1-052	562-04060-200	AIR VENT VALVE B	1		
1-053	031-32710-210	COLLAR	2		
1-054	629-11600-900	TANK INNER CAP ASS'Y	1		
1-055	874-32710-210	HOLDER PLATE B	1		
1-056	992-10060-012	S.WASHER 6	2		
1-057	990-51060-203	HEX. HOLE BOLT 6X20	2		
1-058	992-01050-011	WASHER 5	2	M	
1-059	992-10050-012	S.WASHER 5	2	M	
1-060.1	990-11050-161	SCREW 5X16	2	M	
1-060	994-15050-165	SCREW 5X16/PS	2		
1-063	994-15040-182	SCREW 4X18/PS	2		
1-064	243-32710-200	DAMPER REAR STAY	1	I -J075960	
1-064	243-32710-201	DAMPER REAR STAY	1	J075961-	
1-065	873-32710-800	HOLDER PLATE A COMP.	1		
1-066	203-10000-200	PRIMARY CORD GROMMET	1		
1-071	162-01300-900	STOP SWITCH ASS'Y	1	R -G038400	
1-071	162-01570-900	STOP SWITCH ASS'Y	1	G038401-	
1-072	183-01300-200	SWITCH NAME PLATE	1		
1-073	274-01700-800	EARTH CORD COMP.	1		
1-074	031-32750-200	COLLAR	2		

FIG.2 MUFFLER & CLEANER

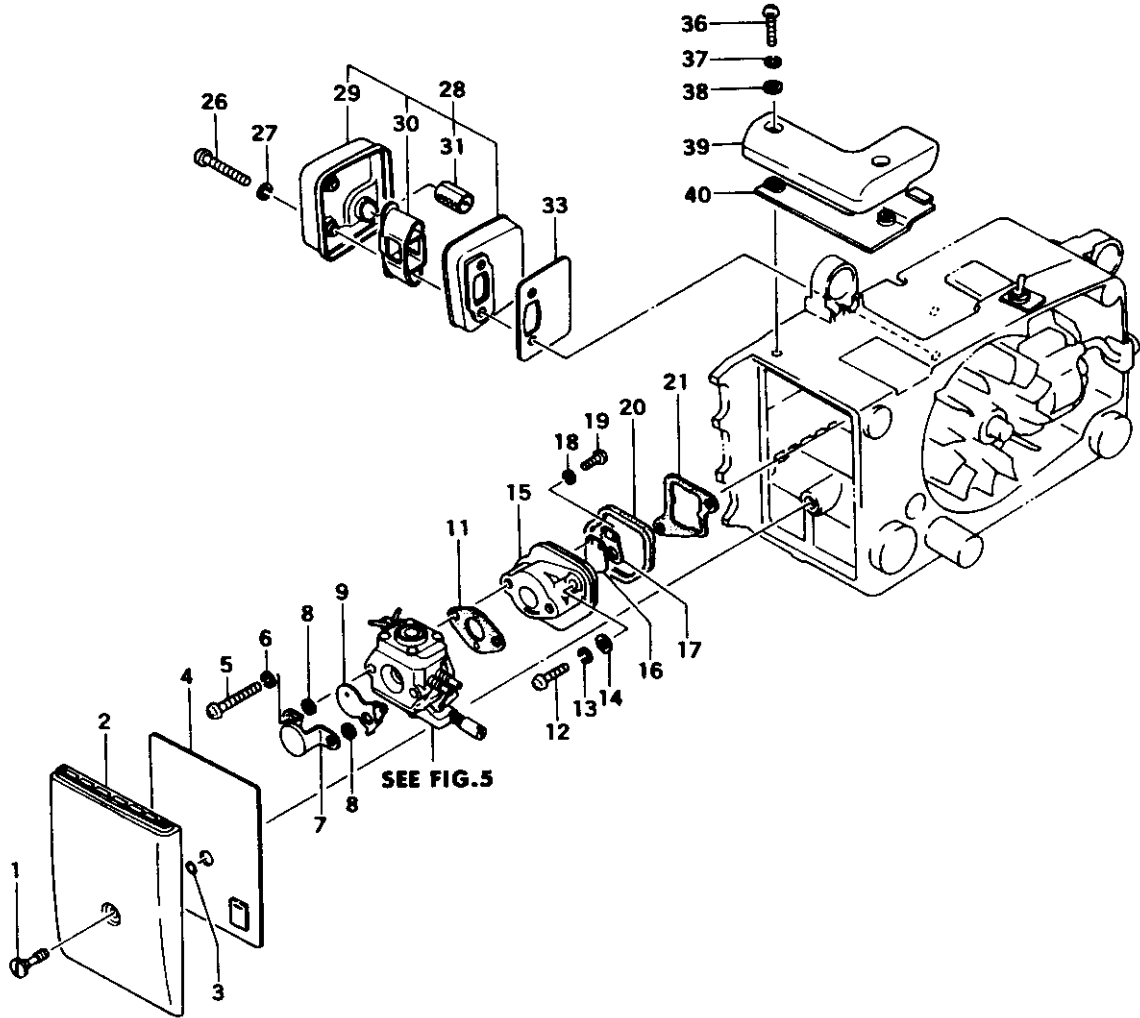

REF. NBR	PART NBR	PART NAME	QTY	SERIAL NBR	REMARKS
2-001	170-32710-200	AIR CLEANER BOLT	1		
2-002	051-32710-200	CLEANER COVER A	1		
2-003	999-67003-000	O-RING P-3	1		
2-004	420-01700-800	CLEANER ELEMENT COMP.	1		
2-005	990-11050-401	SCREW 5X40	2		
2-006	992-10050-012	S. WASHER 5	2		
2-007	476-01700-200	BLOW OVER CHECK BOARD	1		
2-008	708-32350-200	CHOKE VALVE SHIM	2		
2-009	700-32710-200	CHOKE VALVE	1		
2-011	402-01700-200	CARBURETOR GASKET	1		
2-012	990-51050-253	HEX. HOLE BOLT 5X25	2	R -F109350	
2-012	990-11050-252	SCREW 5X25	2	N	
2-012	990-11050-257	SCREW 5X25, STAINLESS	2	F109351-	
2-013	992-10050-012	S. WASHER 5	2		
2-014	992-00050-011	SMALL WASHER 5	2		
2-015	404-01700-800	CARBURETOR INSULATOR COMP.	1	I -F109350	
2-015	404-01700-801	CARBURETOR INSULATOR COMP.	1	F109351-	
2-016	394-01700-200	REED VALVE	1		
2-017	395-01700-200	REED VALVE HOLDER	1		
2-018	992-10030-012	S. WASHER 3	2		
2-019	990-11030-121	SCREW 3X12	2		
2-020	409-01700-200	CARBURETOR INSULATOR RUBBER	1		
2-021	403-01700-200	INLET MANIFOLD GASKET	1		
2-026	990-11050-351	SCREW 5X35	2		
2-027	992-01050-011	WASHER 5	2		
2-028	705-01700-900	MUFFLER ASS'Y	1	-F131500	
2-028	705-01710-900	MUFFLER ASS'Y	1	N F131501-	
2-029	717-01700-800	MUFFLER BODY B COMP.	1	-F131500	
2-029	717-01712-800	MUFFLER BODY B COMP.	1	N F131501-	
2-030	724-01700-200	MUFFLER FITTING METAL	1		
2-031	732-01700-200	SPARK ARRESTOR	1	-F131500	
2-031	732-01710-200	SPARK ARRESTOR	1	N F131501-	
2-033	737-01700-200	MUFFLER GASKET	1		
2-036	993-41040-251	SCREW 4X25	2		
2-037	992-10040-012	S. WASHER 4	2		
2-038	992-00040-011	SMALL WASHER 4	2		
2-039	152-32710-200	CLEANER COVER B	1		
2-040	153-32710-200	CLEANER COVER C	1		

FIG.3 OIL FILTER & PUMP FILTER

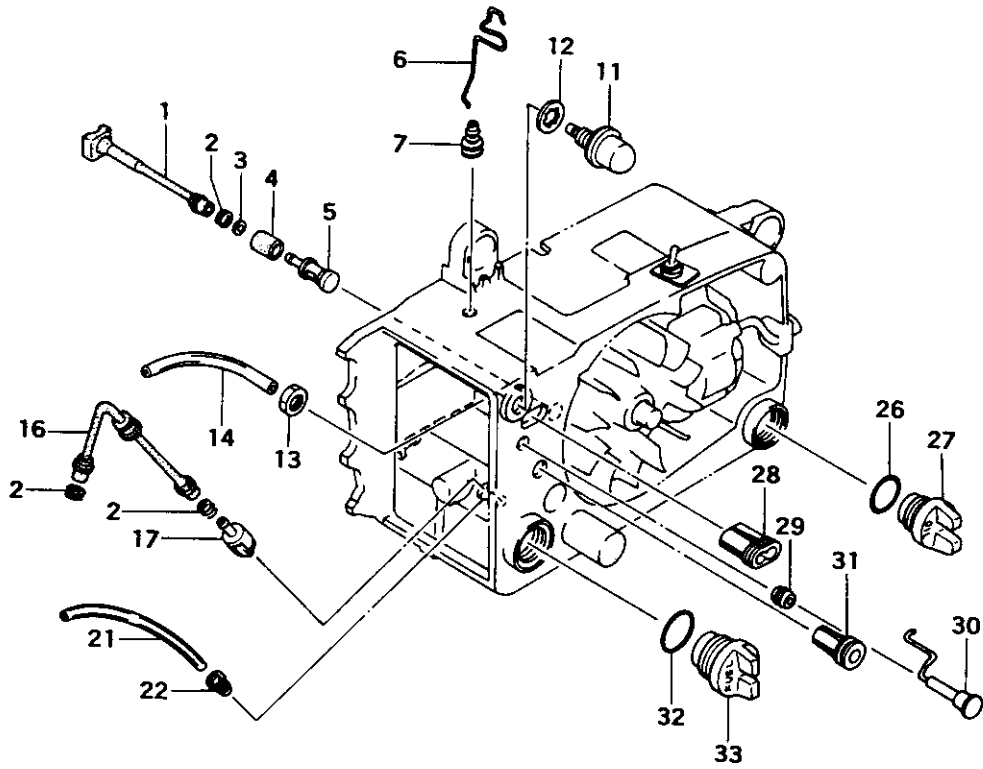

REF. NBR	PART NBR	PART NAME	QTY	SERIAL NBR	REMARKS
3-001	505-32710-200	OIL PIPE B	1		
3-002	680-04019-210	CLIP 7	3		
3-003	992-01050-011	WASHER 5	1		
3-004	487-32712-200	OIL FILTER	1	R -F109350	
3-004	487-32712-201	OIL FILTER	1	F109351-	
3-005	486-32710-200	OIL FILTER BODY	1		
3-006	490-32710-200	THROTTLE ROD	1		
3-007	491-32710-200	THROTTLE GUIDE	1		
3-011	442-25016-801	PRIMING PUMP COMP.	1		
3-012	992-20100-010	INNER TOOTHED WASHER 10	1		
3-013	991-11100-011	NUT 10	1		
3-014	700-02004-105	FUEL PIPE 2X4X105	1	R -G038400	
3-014	700-02504-105	FUEL PIPE 2.5X4X105	1	G038401-	
3-016	678-01700-200	RUBBER PIPE	1		
3-017	675-11600-900	PUMP FILTER BODY ASS'Y	1		
3-021	700-02004-150	FUEL PIPE 2X4X150	1	R -G038400	
3-021	700-02504-150	FUEL PIPE 2.5X4X150	1	G038401-	
3-022	534-32710-200	RETURN GRONMET	1		
3-026	999-67018-000	O-RING P-18	1		
3-027	520-32710-200	OIL TANK CAP	1	I -F131000	
3-027	520-32710-201	OIL TANK CAP	1	F131001-	
3-028	190-32710-200	ADJUSTER CAP	1		
3-029	707-32710-200	GRONMET	1		
3-030	704-32710-800	CHOKE BUTTON COMP.	1		
3-031	191-32710-200	GRONMET	1		
3-032	999-67020-000	O-RING P-20	1		
3-033	628-32710-200	FUEL TANK CAP	1	I -F131000	
3-033	628-32710-201	FUEL TANK CAP	1	F131001-	

FIG.4 RECOIL STARTER

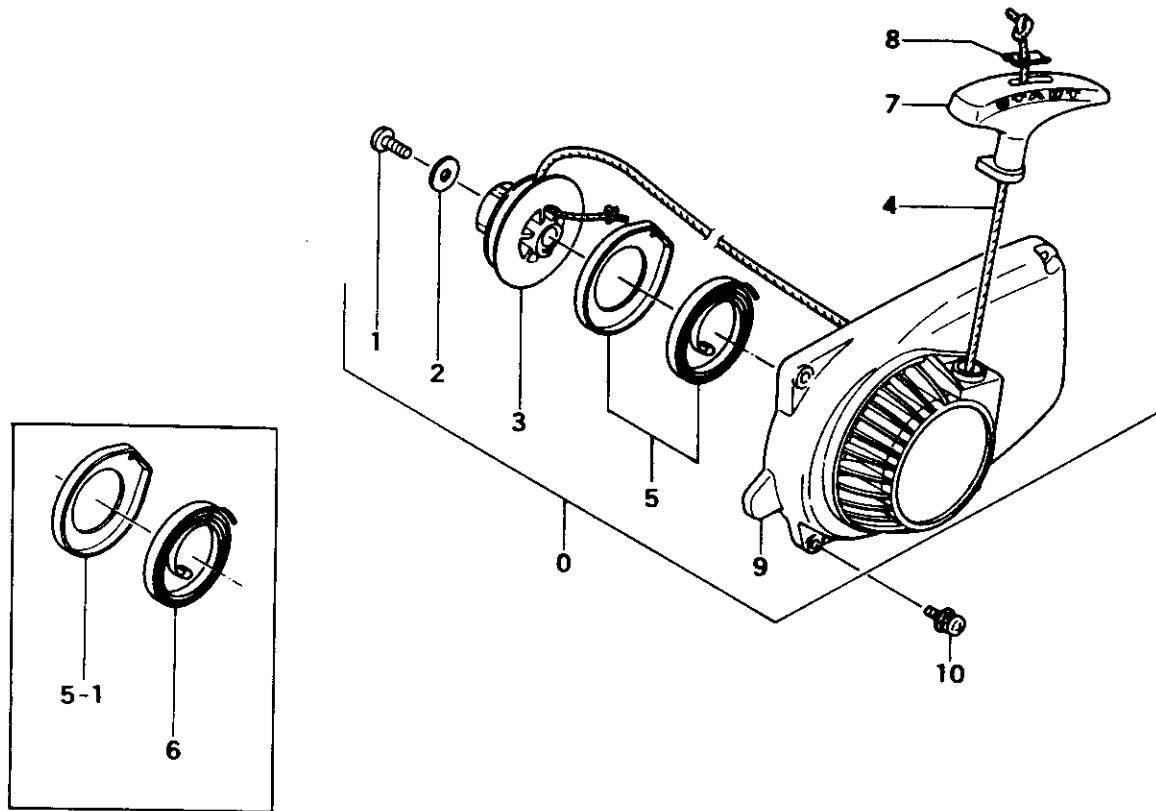

REF. NBR	PART NBR	PART NAME	QTY	SERIAL NBR	REMARKS
4-000	756-01700-900	RECOIL STARTER ASS'Y	1	I -F131000	
4-000	756-01700-901	RECOIL STARTER ASS'Y	1	F131001-	
4-001	990-15050-126	SCREW 5X12	1		
4-002	786-01700-200	RECOIL STARTER WASHER	1		
4-003	774-01700-200	STARTER ROPE REEL	1		
4-004	783-01700-200	STARTER ROPE	1	I -F131000	
4-004	783-01700-201	STARTER ROPE	1	F131001-	
4-005	778-01700-200	RECOIL SPRING CASE	1	R -F131000	
4-005	778-01700-901	RECOIL SPRING CASE ASS'Y	1	F131001-	
4-006	779-01250-200	RECOIL SPRING	1	D F131001-	
4-007	785-04063-200	STARTER HANDLE	1		
4-008	795-04063-200	ROPE STOPPER	1		
4-009	112-01700-800	FAN CASE COMP.	1	I -F131000	
4-009	112-01700-801	FAN CASE COMP.	1	F131001-	
4-010	994-15040-182	SCREW 4X18/PS	4		

FIG.5 CARBURETOR

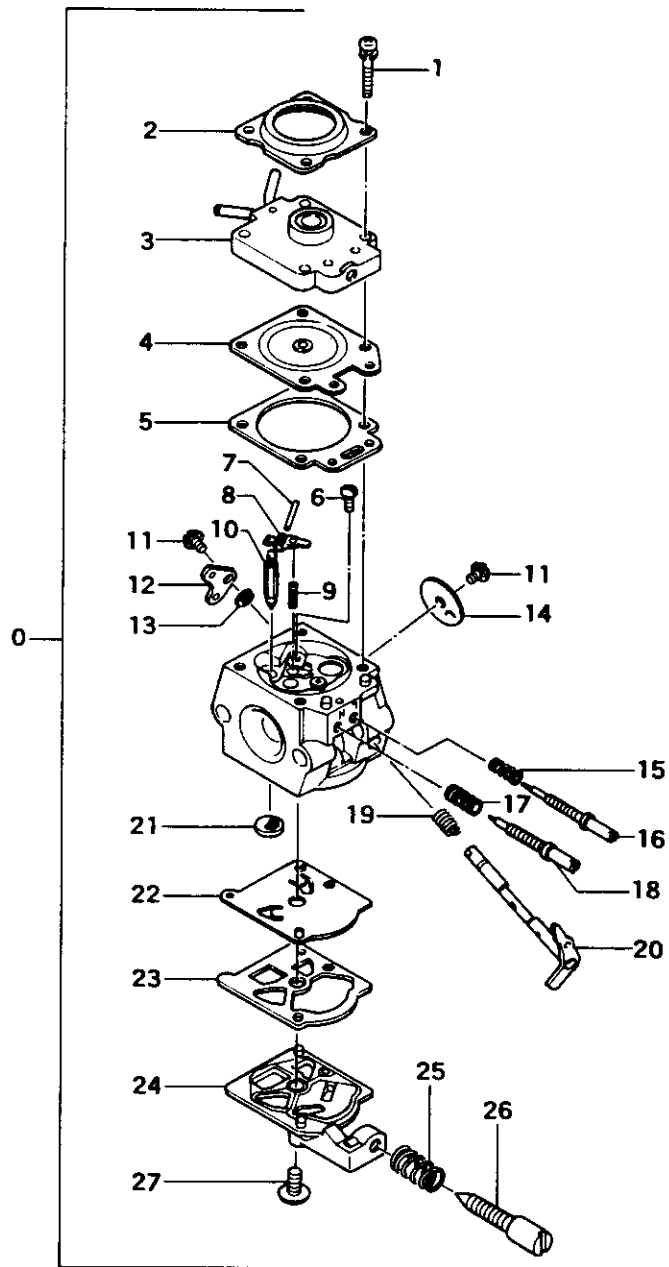

REF. NBR	PART NBR	PART NAME	QTY	SERIAL NBR	REMARKS
5-000	455-25027-900	CARBURETOR ASS'Y	1	R -F109350	
5-000	455-25027-901	CARBURETOR ASS'Y	1	F109351-	
5-001	548-25016-200	SET SCREW	4		
5-002	476-25016-200	DIAPHRAGM COVER	1		
5-003	454-25027-800	AIR PURGE COMP.	1		
5-004	474-25001-800	METERING DIAPHRAGM COMP.	1		
5-005	475-25016-200	DIAPHRAGM GASKET	1		
5-006	546-25001-200	HINGE PIN SET SCREW	1		
5-007	605-25001-200	HINGE PIN	1		
5-008	473-25001-200	VALVE HINGE	1		
5-009	477-25007-200	VALVE SPRING	1	R -F109350	
5-009	477-25013-200	VALVE SPRING	1	F109351-	
5-010	603-25001-200	NEEDLE VALVE	1		
5-011	467-25003-200	SHUTTER SCREW	2		
5-012	491-25027-200	THROTTLE LEVER	1		
5-013	489-25007-200	STOP RING	1		
5-014	488-25027-200	THROTTLE VALVE	1	R -F109350	
5-014	488-25008-200	THROTTLE VALVE	1	F109351-	
5-015	623-25001-200	HIGH/LOW ADJUST SPRING	1		
5-016	461-25027-200	LOW ADJUST SCREW	1		
5-017	485-25003-200	HIGH ADJUST SPRING	1		
5-018	460-25027-200	HIGH ADJUST SCREW	1		
5-019	486-25015-200	THROTTLE SPRING	1		
5-020	464-25027-800	THROTTLE SHAFT COMP.	1		
5-021	578-25007-200	INLET SCREEN	1		
5-022	576-25006-200	PUMP DIAPHRAGM	1		
5-023	577-25007-200	PUMP GASKET	1		
5-024	575-25010-200	PUMP BODY	1	R -F109350	
5-024	575-25028-200	PUMP BODY	1	F109351-	
5-025	463-25006-200	IDLE ADJUST SPRING	1		
5-026	462-25016-200	IDLE ADJUST SCREW	1		
5-027	514-25001-200	SET SCREW	1		

FIG.6 OIL PUMP & SIDE CASE

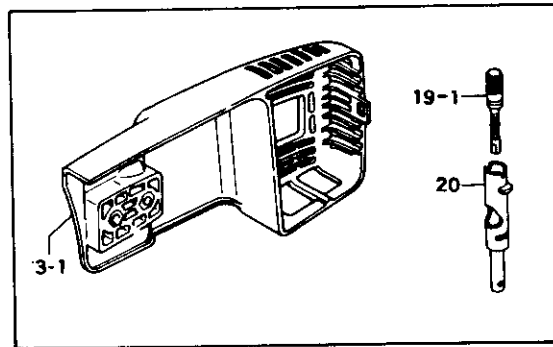
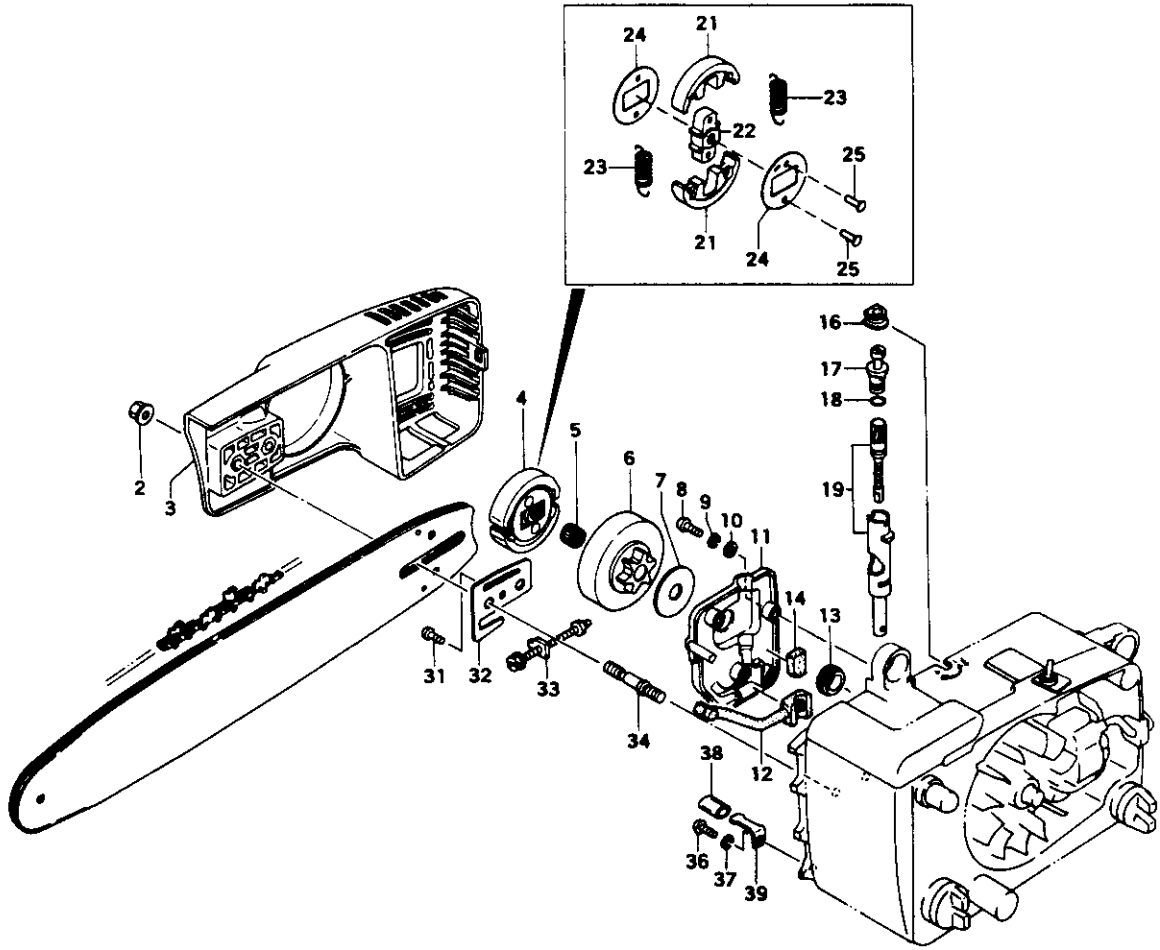

REF. NBR	PART NBR	PART NAME	QTY	SERIAL NBR	REMARKS
6-002	121-32530-200	CHAIN BAR CLAMP NUT	2		
6-003, 1	040-32710-800	SIDE CASE COMP.	1	R -F131000	
6-003	040-32710-810	SIDE CASE COMP.	1	R -G038400	
6-003	040-32710-811	SIDE CASE COMP.	1	G038401-	
6-004	287-01700-800	CLUTCH COMP.	1		
6-005	999-62101-301	NEEDLE BEARING 101310	1		
6-006	310-32710-200	CLUTCH HOUSING 3/8"	1		
6-007	358-04050-201	CLUTCH WASHER	1		
6-008	990-11040-121	SCREW 4X12	4		
6-009	992-10040-012	S. WASHER 4	4		
6-010	992-00040-011	SMALL WASHER 4	4		
6-011	097-32710-800	OIL PUMP COVER COMP.	1		
6-012	515-32710-200	OIL PIPE A	1		
6-013	084-32710-201	SCREW GEAR	1		
6-014	567-01700-200	AIR VENT SPONGE	1		
6-016	488-32710-200	OIL ADJUST GROMMET	1	R -F131000	
6-016	488-32710-210	OIL ADJUST GROMMET	1	F131001-	
6-017	501-32710-200	OIL PUMP ADJUSTER	1	-F131000	
6-017	501-32710-210	OIL PUMP ADJUSTER	1	N F131001-	
6-018	999-67007-000	O-RING P-7	1		
6-019, 1	085-32710-200	PUMP GEAR	1	-F131000	
6-019	088-32710-910	OIL PUMP CASE SET	1	N F131001-	
6-020	088-32710-200	OIL PUMP CASE	1	D F131001-	
6-021	345-01700-200	CLUTCH SHOE	2		
6-022	346-01700-200	CLUTCH BOSS	1		
6-023	342-01700-200	CLUTCH SPRING	2		
6-024	348-01700-200	CLUTCH PLATE A	2		
6-025	992-74004-143	RIVET 4X14	2		
6-031	993-41040-101	SCREW 4X10	1		
6-032	466-32710-200	PLATE	1		
6-033	116-32710-900	TENSION ADJUSTMENT BOLT ASS'Y	1		
6-034	101-32530-200	CHAIN BAR STUD BOLT	2		
6-036	990-11050-121	SCREW 5X12	1		
6-037	992-10050-012	S. WASHER 5	1		
6-038	700-07105-020	VINYL PIPE	1		
6-039	125-32710-200	CHAIN CATCHER	1		

FIG.7 HANDLE

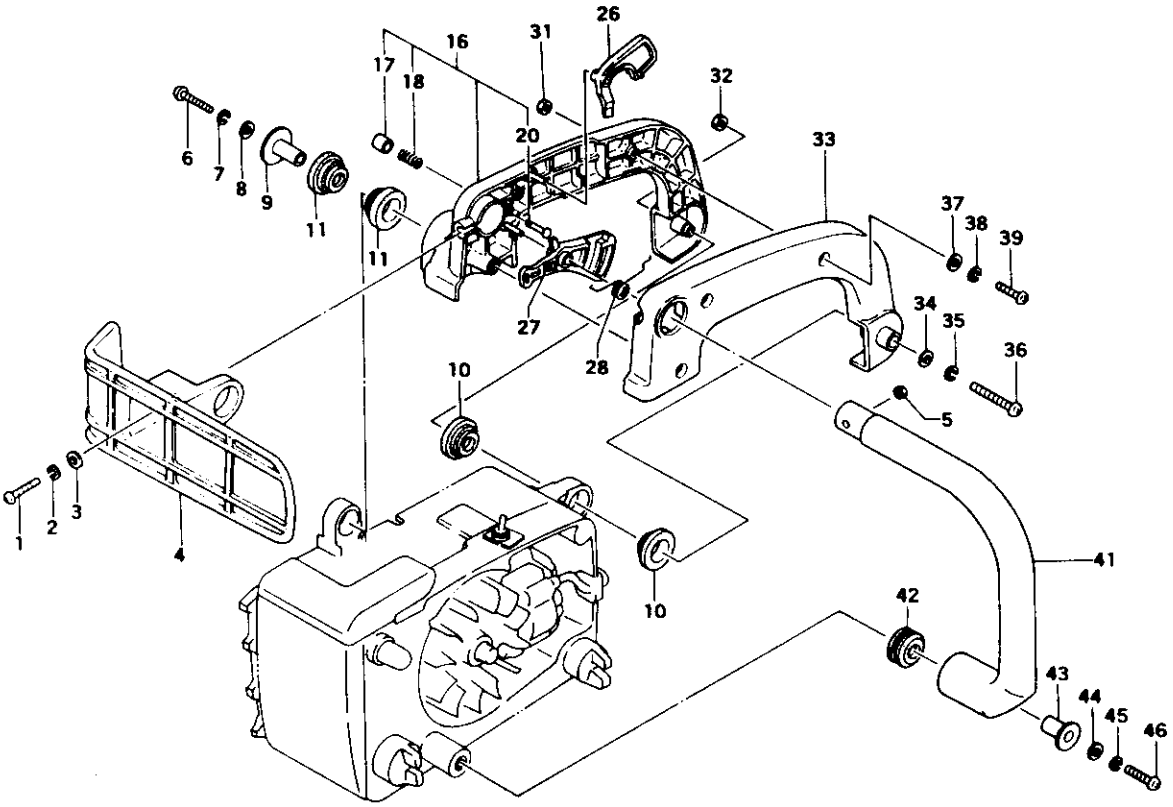

REF. NBR	PART NBR	PART NAME	QTY	SERIAL NBR	REMARKS
7-001	990-11040-351	SCREW 4X35	1		
7-002	992-10040-012	S.WASHER 4	1		
7-003	992-01040-011	WASHER 4	1		
7-004	805-32710-800	FRONT HAND GUARD COMP.	1		
7-005	991-74040-010	U-NUT 4	1		
7-006	990-11050-351	SCREW 5X35	1		
7-007	992-10050-012	S.WASHER 5	1		
7-008	992-00050-011	SMALL WASHER 5	1		
7-009	275-32710-200	DAMPER COLLAR A	1	I -J075960	
7-009	275-32710-201	DAMPER COLLAR A	1	J075961-	
7-010	219-32710-200	DAMPER A	4	-J075960	
7-010	219-32710-200	DAMPER A	2	J075961-	
7-011	219-32750-200	DAMPER A	2	N J075961-	
7-016	011-32710-800	REAR HANDLE B COMP.	1		
7-017	725-32600-202	PUSH PIN CAP	1		
7-018	066-32300-201	STOPPER SPRING	1		
7-020	064-32530-200	PUSH PIN	1		
7-026	257-32710-200	SAFETY LEVER	1		
7-027	060-32710-200	THROTTLE LEVER	1		
7-028	061-32710-200	THROTTLE LEVER SPRING	1		
7-031	991-01040-011	HEX. NUT 4	2		
7-032	991-01050-011	HEX. NUT 5	1		
7-033	010-32710-200	REAR HANDLE A	1		
7-034	992-00050-011	SMALL WASHER 5	1		
7-035	992-10050-012	S.WASHER 5	1		
7-036	990-11050-401	SCREW 5X40	1		
7-037	992-00040-011	SMALL WASHER 4	3		
7-038	992-10040-012	S.WASHER 4	3		
7-039	990-11040-181	SCREW 4X18	3		
7-041	209-32710-200	FRONT HANDLE	1		
7-042	266-32710-200	DAMPER B	1	I -J075960	
7-042	266-32750-200	DAMPER B	1	J075961-	
7-043	276-32710-200	DAMPER COLLAR B	1	I -J075960	
7-043	276-32710-201	DAMPER COLLAR B	1	J075961-	
7-044	992-00050-011	SMALL WASHER 5	1		
7-045	992-10050-012	S.WASHER 5	1		
7-046	990-11050-301	SCREW 5X30	1		

FIG.8 TOOLS

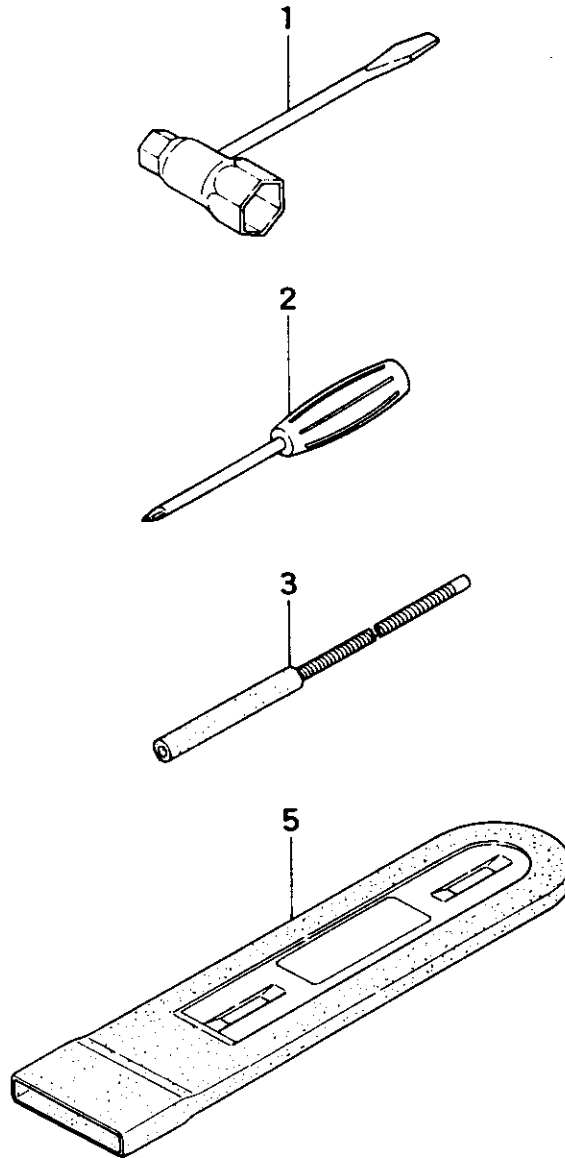

REF. NBR	PART NBR	PART NAME	QTY	SERIAL NBR	REMARKS
8-001	013-29323-501	COMBI. BOX SPANNER 10X19	1		
8-002	862-20000-200	PLUS DRIVER 4	1		
8-003	936-20000-900	FILE ASS'Y 5/32"	1		
8-005	943-32710-200	CHAIN COVER 12"	1	-G038400	
8-005	943-32710-201	CHAIN COVER 12"	1	G038401-	

FIG.9 MARKS

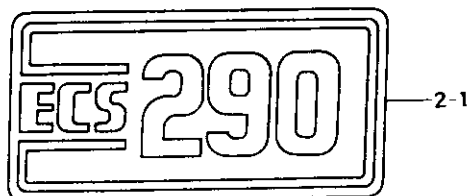

WARNING

Read and follow all safety precautions in the owner's manual. Failure to follow instructions could result in serious injury. Avoid contact of bar tip with any object. This may cause bar to "KICK BACK" suddenly, which may cause serious injury. Always use two hands to operate the saw. The following bar and chain combinations are approved for reducing kickback:
 TANAKA Chain 915GU45X and Bar 31649
 OREGON® Chain 915G-45E and Bar 120SZEAO41

REF. NBR	PART NBR	PART NAME	QTY	SERIAL NBR	REMARKS
9-001,1	915-32710-200	STARTER MARK	1 R	-G038400	
9-001,2	915-32710-201	STARTER MARK	1	-J075960	
9-001	950-32710-200	PROFORCE MARK A	1 N	J075961-	
9-002,1	906-32710-200	NAME PLATE	1	-J075960	
9-002	906-01700-200	NAME PLATE	1 N	J075961-	
9-003	907-32750-200	CAUTION MARK	1		

Free Manuals Download Website

<http://myh66.com>

<http://usermanuals.us>

<http://www.somanuals.com>

<http://www.4manuals.cc>

<http://www.manual-lib.com>

<http://www.404manual.com>

<http://www.luxmanual.com>

<http://aubethermostatmanual.com>

Golf course search by state

<http://golfingnear.com>

Email search by domain

<http://emailbydomain.com>

Auto manuals search

<http://auto.somanuals.com>

TV manuals search

<http://tv.somanuals.com>