

***Tanaka***

---

**Parts Catalog**

**Chainsaw**

**Model: ECS-356**

**Units Prior To Serial No. F 115148**

# FIG.1 ENGINE

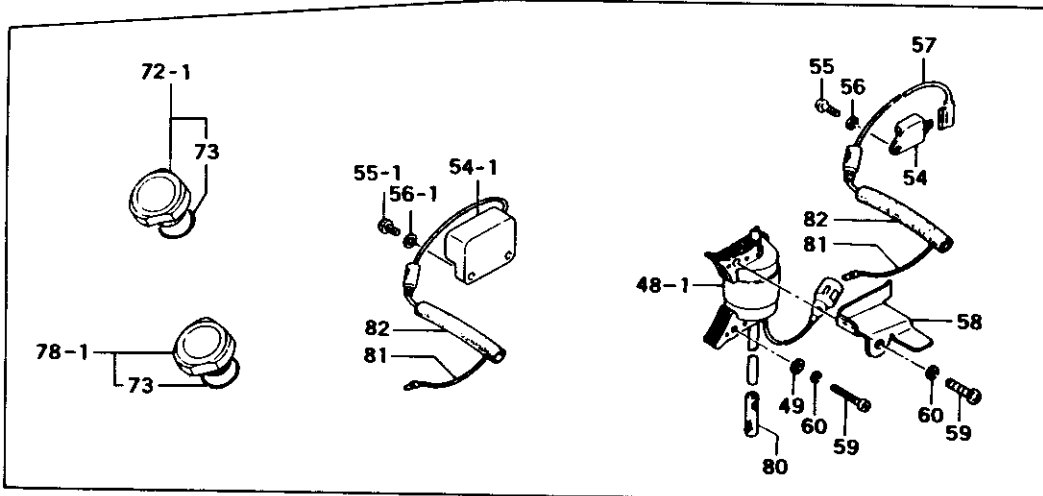
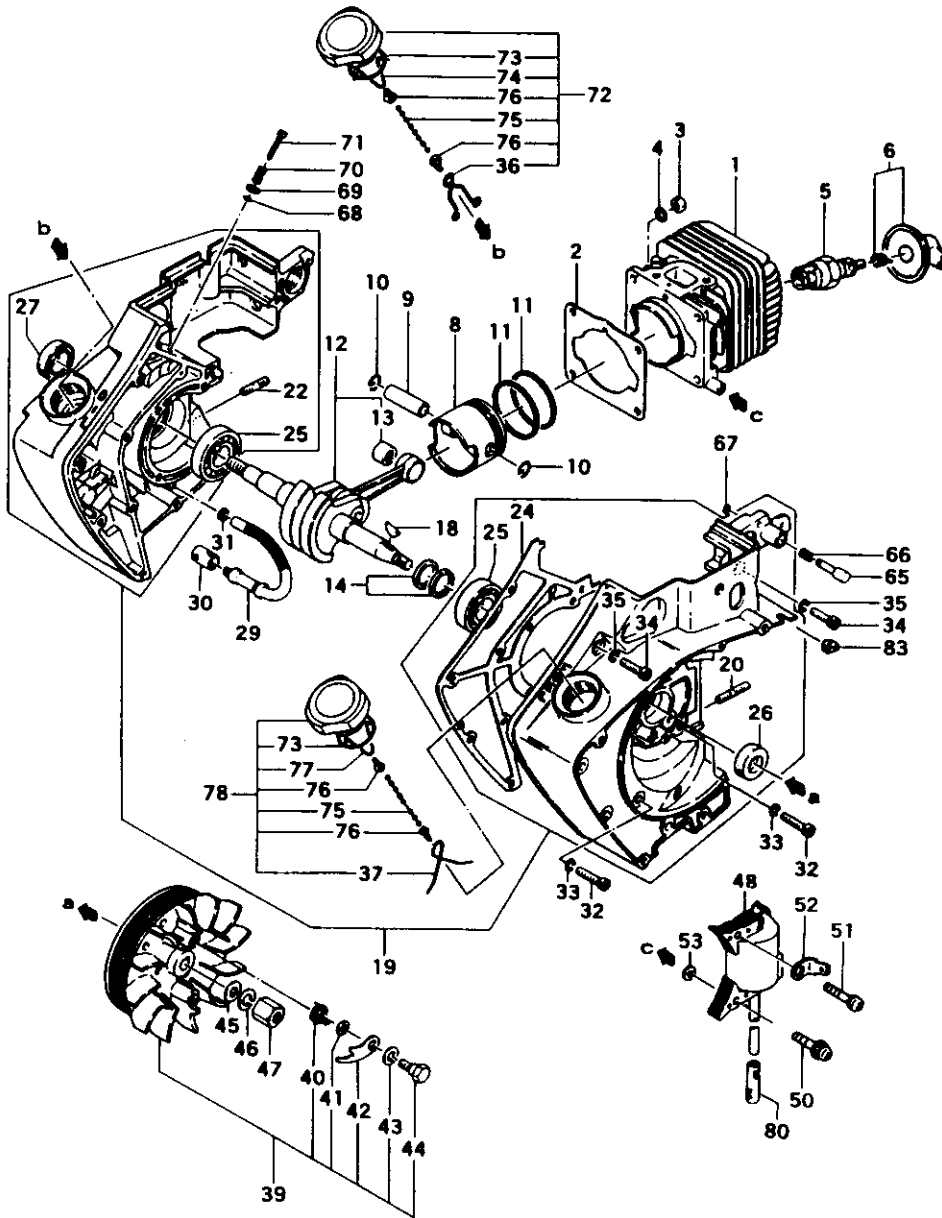

REF. NBR	PART NBR	PART NAME	QTY	SERIAL NBR	REMARKS
1-001	002-01800-211	CYLINDER	1	-F098200	
1-001	002-01800-220	CYLINDER	1	N F098201-	
1-002	017-01800-200	CYLINDER GASKET	1		
1-003	991-01050-011	HEX. NUT 5	4		
1-004	992-10050-012	S. WASHER 5	4		
1-005	018-00502-200	SPARK PLUG BM6A	1	-F098200	
1-005	018-01805-200	SPARK PLUG CJ8	1	N F098201-	
1-006	157-01800-900	SPARK PLUG CAP ASS'Y	1	R -C164999	
1-006	157-01800-901	SPARK PLUG CAP ASS'Y	1	C165000-	
1-008	031-01800-200	PISTON	1		
1-009	037-01400-200	PISTON PIN	1		
1-010	039-00000-201	PISTON PIN CIRCLIP	2		
1-011	041-04000-200	PISTON RING	2		
1-012	046-01800-800	CRANK SHAFT COMP.	1		
1-013	999-62091-325	NEEDLE BEARING F-910	1		
1-014	071-02007-200	CRANK SHAFT SHIM 0.05	V		
1-014	071-02007-210	CRANK SHAFT SHIM 0.10	V		
1-014	071-02007-220	CRANK SHAFT SHIM 0.15	V		
1-014	071-02007-230	CRANK SHAFT SHIM 0.20	V		
1-018	068-10100-200	WOOD-RUFF KEY 3X13X4.5	1		
1-019	072-01800-900	CRANK CASE ASS'Y	1	R -D164255	VERMILION
1-019	072-01800-901	CRANK CASE ASS'Y	1	R -E155100	VERMILION
1-019	072-01800-902	CRANK CASE ASS'Y	1	-F098200	VERMILION
1-019	072-01850-901	CRANK CASE ASS'Y	1	N F098201-	
1-020	100-00501-200	STUD BOLT 5X26	2		
1-022	100-00100-201	STUD BOLT 5X21	2		
1-024	090-01800-203	CRANK CASE GASKET	1		
1-025	999-61620-200	BALL BEARING #6202. 35MM/OD	2		
1-026	999-66122-266	OIL SEAL 12227	1	R -D164255	
1-026	999-66122-200	OIL SEAL 12227	1	D164256-	
1-027	999-66152-500	OIL SEAL 15257	1		
1-029	505-32350-202	OIL PIPE B	1	R -D164255	
1-029	505-32350-203	OIL PIPE B	1	D164256-	
1-030	510-32350-200	FILTER NET	1		
1-031	680-00803-201	CLIP	1	I -D217300	
1-031	680-00803-202	CLIP	1	D217301-	
1-032	990-51050-253	HEX. HOLE BOLT 5X25	10		
1-033	992-10050-012	S. WASHER 5	10		
1-034	990-51050-223	HEX. HOLE BOLT 5X22	2		
1-035	992-10050-012	S. WASHER 5	2		
1-036	641-32350-201	OIL TANK CAP HOOK	1	N C101431-	
1-036	641-32350-201	OIL TANK CAP HOOK	1	R -D217300	
1-036	641-32350-202	OIL TANK CAP HOOK	1	D217301-	
1-037	596-35100-202	FUEL TANK CAP HOOK	1	N C101431-	
1-039	155-21704-900	MAGNETO ROTOR ASS'Y	1	R -C175466	
1-039	155-21704-901	MAGNETO ROTOR ASS'Y	1	I -C193852	
1-039	155-21704-910	MAGNETO ROTOR ASS'Y	1	I -D130490	
1-039	155-21704-911	MAGNETO ROTOR ASS'Y	1	D130491-	
1-040	790-01800-200	STARTER PAWL SPRING	2		
1-041	786-00601-200	STARTER PAWL WASHER	2		
1-042	788-00601-203	STARTER PAWL	2		
1-043	822-00601-200	STARTER PAWL SHIM 0.6T	2		
1-044	793-10200-201	STEP BOLT	2		
1-045	065-00000-200	FLYWHEEL WASHER	1		
1-046	992-10070-012	S. WASHER 7	1		
1-047	066-01800-200	FLYWHEEL NUT	1		
1-048, 1	167-20738-800	IGNITION COIL COMP.	1	R -C163100	
1-048, 1	167-20763-800	IGNITION COIL COMP.	1	-F098200	
1-048	167-21850-800	IGNITION COIL COMP.	1	N F098201-	
1-049	992-00040-011	SMALL WASHER 4	1	D F098201-	
1-050	994-16040-226	SCREW 4X22/VS	1	N F098201-	
1-051	994-14040-226	SCREW 4X22/S	1	N F098201-	
1-052	205-11600-201	TERMINAL TAB	1	N F098201-	

- To be cont'd -

REF. NBR	PART NBR	PART NAME	QTY	SERIAL NBR	REMARKS
1-053	182-0186A-200	WASHER	1	N F098201-	
1-054, 1	159-21401-870	IGNITOR COMP. TTI-1D	1	R -C175466	
1-054, 1	159-21401-871	IGNITOR COMP. TTI-1E	1	-E155100	
1-054	159-21401-872	IGNITOR COMP. TTI-1F	1	N E155101-	
1-054	159-21401-872	IGNITOR COMP. TTI-1F	1	D F098201-	
1-055, 1	990-11040-181	SCREW 4X16	2	-E155100	
1-055	990-11040-081	SCREW 4X8	1	N E155101-	
1-055	990-11040-081	SCREW 4X8	1	D F098201-	
1-056, 1	992-10040-012	S. WASHER 4	2	-E155100	
1-056	992-10040-012	S. WASHER 4	1	E155101-	
1-056	992-10040-012	S. WASHER 4	1	D F098201-	
1-057	173-0162R-800	IGNITOR LEAD WIRE COMP., R85W	1	N E155101-	
1-057	173-0162R-800	IGNITOR LEAD WIRE COMP., R85W	1	D F098201-	
1-058	198-01800-210	CORD CLAMP	1	R -C163200	
1-058	198-01800-220	CORD CLAMP	1	R -C167493	
1-058	198-01800-221	CORD CLAMP	1	R -D164255	
1-058	198-01800-230	CORD CLAMP	1	D164256-	
1-058	198-01800-230	CORD CLAMP	1	D F098201-	
1-059	990-11040-181	SCREW 4X18	2	D F098201-	
1-060	992-10040-012	S. WASHER 4	2	D F098201-	
1-065	064-32300-200	PUSH PIN	1	R -C170669	
1-065	064-32300-201	PUSH PIN	1	C170670-	
1-066	066-32300-201	STOPPER SPRING	1		
1-067	993-55030-002	STOP RING 3	1		
1-068	999-67003-000	O-RING P-3	1		
1-069	992-01040-011	WASHER 4	1		
1-070	502-32302-200	ADJUSTER SPRING	1		
1-071	501-32350-201	OIL PUMP ADJUSTER	1		
1-072, 1	624-32354-901	OIL TANK CAP ASSY	1	R -C101430	
1-072	624-32350-901	OIL TANK CAP ASS'Y	1	C101431-	
1-073	999-67022-000	O-RING P-22	2		
1-074	634-32350-200	OIL TANK CAP HOOK	1	N C101431-	
1-075	626-32350-201	TANK CAP CHAIN	2	N C101431-	
1-076	627-32350-201	BALL CHAIN END	4	N C101431-	
1-077	596-32377-200	TANK CAP HOOK B	1	N C101431-	
1-077	596-32377-200	TANK CAP HOOK B	1	R -C162900	
1-077	596-32377-210	FUEL TANK CAP HOOK	1	-C162901	
1-078, 1	635-32050-910	FUEL TANK CAP ASS'Y	1	R -C101430	
1-078	635-32377-900	FUEL TANK CAP ASS'Y	1	R -C162900	
1-078	635-32377-901	FUEL TANK CAP ASS'Y	1	C162901-	
1-080	755-32050-200	CORD INSULATOR TUBE	1		
1-081	178-00601-801	STOP CORD COMP.	1	-C163200	
1-081	178-00610-801	STOP CORD COMP.	1	N C163201-	
1-081	178-00610-801	STOP CORD COMP.	1	D F098201-	
1-082	203-01800-200	CORD GROMMET	1	D F098201-	
1-083	203-06000-200	PRIMARY CORD GROMMET	1	N E155101-	
1-083	203-06000-200	PRIMARY CORD GROMMET	1	D F098201-	

# FIG.2 CLUTCH, BRAKE & MUFFLER

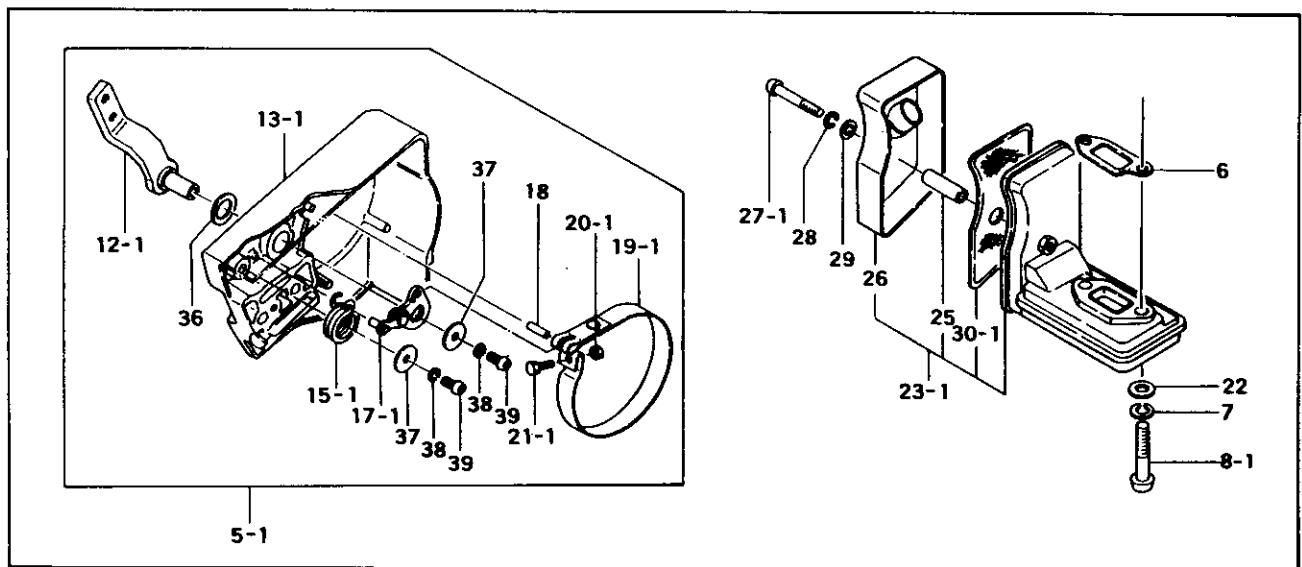
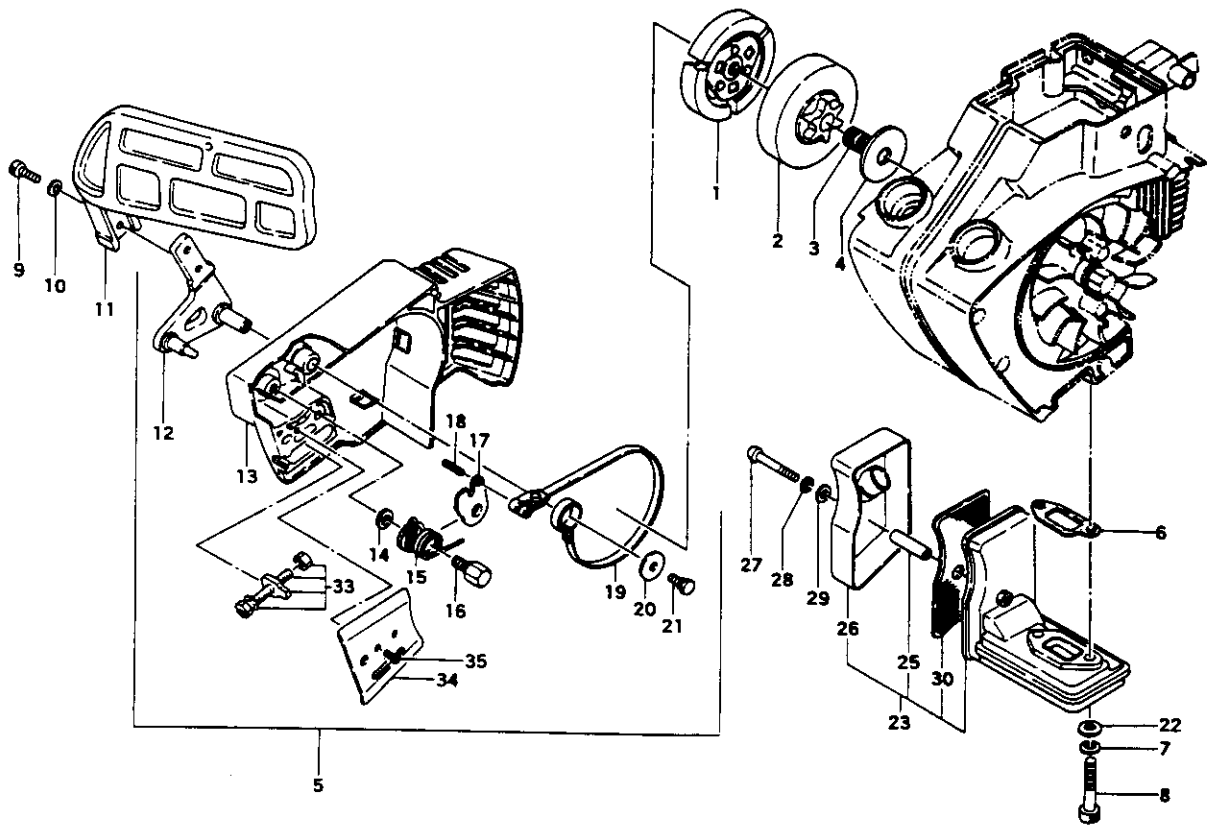

REF. NBR	PART NBR	PART NAME	QTY	SERIAL NBR	REMARKS
2-001	287-01801-800	CLUTCH COMP.	1		
2-002	310-01801-800	CLUTCH HOUSING COMP. P-3/8	1	R -C190152	
2-002	310-01801-801	CLUTCH HOUSING COMP. P-3/8	1	C190153-	
2-003	999-62101-301	NEEDLE BEARING 101310	1		
2-004	358-01800-200	CLUTCH WASHER	1	I -E314140	
2-004	358-01800-201	CLUTCH WASHER	1	E314141-	
2-005.1	040-32377-900	SIDE CASE ASS'Y	1	-D150277	
2-005	040-32055-920	SIDE CASE ASS'Y	1	N -E155100	
2-005	040-32055-920	SIDE CASE ASS'Y	1	R -E155100	
2-005	040-32055-921	SIDE CASE ASS'Y	1	E155101-	
2-006	737-01800-200	MUFFLER GASKET	1		
2-007	992-10060-012	S. WASHER 6	2		
2-008.1	990-70060-351	FT SCREW 6X35	2	-E155100	
2-008	990-51060-353	HEX. HOLE BOLT 6X35	2	N E155101-	
2-009	990-51050-103	HEX. HOLE BOLT 5X10	2		
2-010	992-10050-012	S. WASHER 5	2		
2-011	380-32600-803	BRAKE HANDLE COMP.	1		
2-012.1	361-32377-801	BRAKE LEVER COMP.	1	R -C163200	
2-012.1	361-32377-802	BRAKE LEVER COMP.	1	-D150277	
2-012	361-32367-810	BRAKE LEVER COMP.	1	N D150278-	
2-013.1	040-32350-213	SIDE CASE	1	-D150277	
2-013	040-32055-220	SIDE CASE	1	N -E155100	
2-013	040-32055-800	SIDE CASE COMP.	1	P E155101-	
2-014	871-32367-200	SPECIAL WASHER B	1	N D150278-	
2-015.1	374-32350-210	BRAKE SPRING	1	-D150277	
2-015	374-32367-210	BRAKE SPRING	1	N D150278-	
2-016	382-32367-210	STEP BOLT A	1	N D150278-	
2-017.1	379-32350-800	BRAKE LINK COMP.	1	-D150277	
2-017	373-32367-201	BRAKE ARM	1	N D150278-	
2-018	993-24040-120	SPRING PIN 4X12	1		
2-019.1	378-32350-800	BRAKE BAND COMP.	1	-D150277	
2-019	378-32367-820	BRAKE BAND COMP.	1	N D150278-	
2-020.1	991-01040-013	NUT 4	1	-D150277	
2-020	368-32057-200	BRAKE SHAFT WASHER	1	N D150278-	
2-021.1	990-21040-081	BOLT 4X8	1	-D150277	
2-021	383-32367-210	STEP BOLT B	1	N D150278-	
2-022	992-01060-011	WASHER 6	2		
2-023.1	705-01802-920	MUFFLER ASS'Y	1	R -C101330	
2-023	705-01802-930	MUFFLER ASS'Y W/SPARK ARRESTER	1	C101331-	
2-025	740-01802-200	MUFFLER COLLAR	1		
2-026	717-01800-820	MUFFLER BODY B COMP.	1		
2-027.1	990-11050-351	SCREW 5X35	1	R -C101330	
2-027	994-31050-351	SCREW 5X35	1	C101331-	
2-028	992-10050-012	S. WASHER 5	1		
2-029	992-01050-011	WASHER 5	1		
2-030.1	722-01802-220	MUFFLER PARTITION PLATE	1	-C101330	
2-030	732-01802-201	SPARK ARRESTER	1	N C101331-	
2-033	116-32382-900	TENSION ADJUSTMENT BOLT ASS'Y	1		
2-034	462-32350-210	GUIDE PLATE B	1		
2-035	990-11040-061	SCREW 4X6	1		
2-036	070-00601-201	CRANK SHAFT WASHER 12.2X18	1	D D150278-	
2-037	368-32350-200	BRAKE SHAFT WASHER	2	D D150278-	
2-038	992-10050-012	S. WASHER 5	2	D D150278-	
2-039	990-11050-101	SCREW 5X10	2	D D150278-	

# FIG.3 CARBURETOR & CLEANER

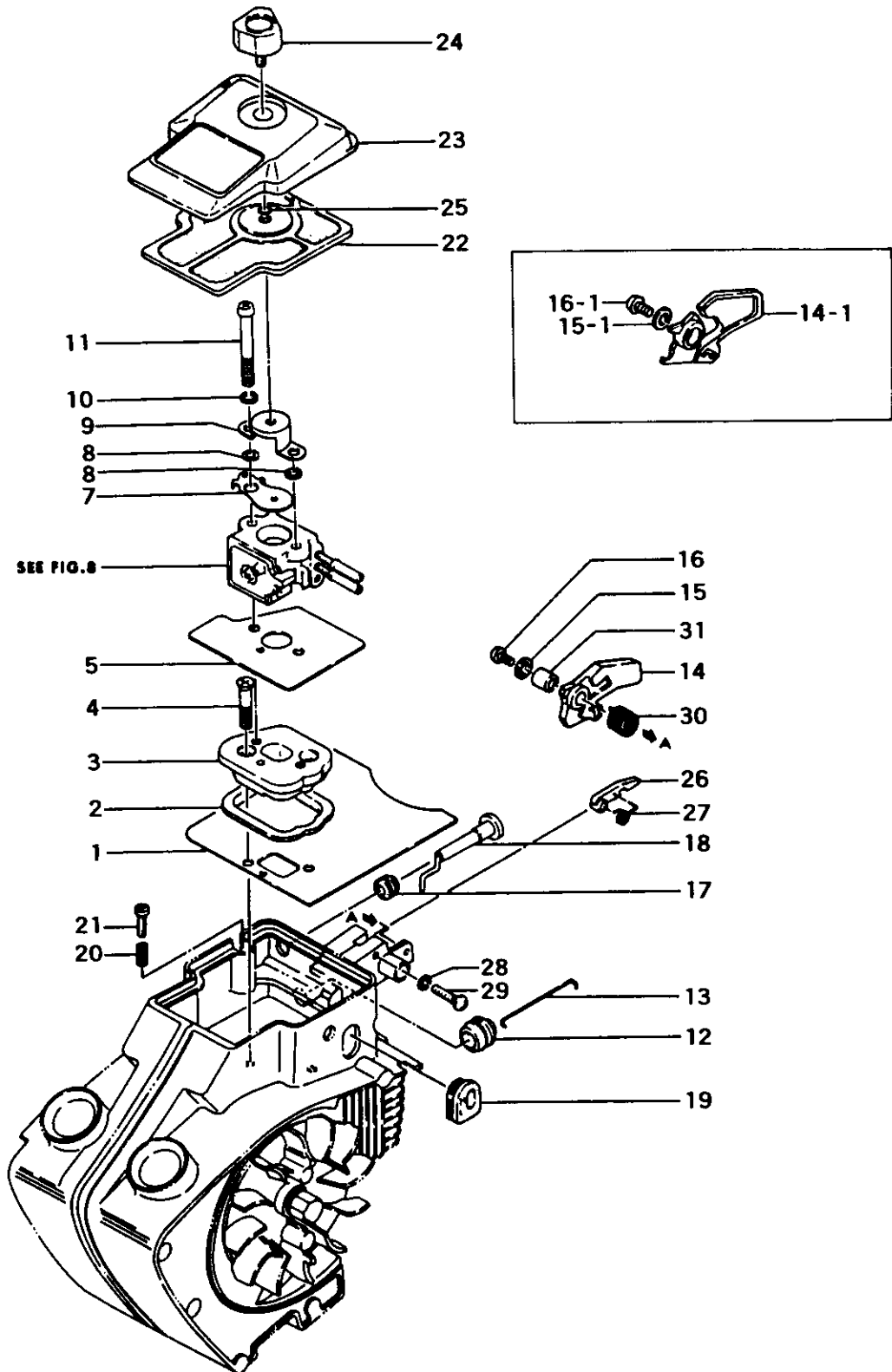

REF. NBR	PART NBR	PART NAME	QTY	SERIAL NBR	REMARKS
3-001	133-01850-200	HEAT SHIELD	1	R -C018017	
3-001	133-01850-201	HEAT SHIELD	1	C016018-	
3-002	409-01800-210	CARBURETOR INSULATOR RUBBER	1		
3-003	404-01800-203	CARBURETOR INSULATOR	1		
3-004	990-12050-251	F.H.SCREW 5X25	2		
3-005	402-01850-200	CARBURETOR GASKET	1		
3-007	700-32350-211	CHOKE VALVE	1		
3-008	708-32350-200	CHOKE VALVE SHIM	2		
3-009	476-01800-200	BLOW OVER CHECK BOARD	1		
3-010	992-10050-012	S.WASHER 5	2		
3-011	990-11050-451	SCREW 5X45	2		
3-012	491-32350-201	THROTTLE GUIDE	1		
3-013	490-32350-210	THROTTLE ROD	1	-F098200	
3-013	490-32050-201	THROTTLE ROD	1	N F098201-	
3-014.1	060-32350-211	THROTTLE LEVER	1	-F098200	
3-014	060-32050-214	THROTTLE LEVER	1	N F098201-	
3-015.1	992-01030-011	WASHER 3	1	-F098200	
3-015	513-32057-200	WASHER	1	N F098201-	
3-016.1	990-11030-121	SCREW 3X12	1	-F098200	
3-016	990-11030-141	SCREW 3X14	1	N F098201-	
3-017	202-01003-201	SECONDARY CORD GRONMET	1		
3-018	704-32350-800	CHOKE BUTTON COMP.	1		
3-019	190-32314-200	ADJUSTER CAP	1		
3-020	845-11107-201	CONTROL LEVER SPRING/RK11	1		
3-021	990-06040-181	F.F.H. SCREW 4X18	1		
3-022	420-01800-801	CLEANER ELEMENT COMP.	1		
3-023	051-32050-210	CLEANER COVER	1		
3-024	156-32050-810	CLEANER CAP KNOB COMP.	1		
3-025	999-67003-000	O-RING P-3	1		
3-026	259-32350-202	THROTTLE LOCK LEVER	1		
3-027	261-32350-201	THROTTLE LOCK SPRING	1		
3-028	992-10040-012	S.WASHER 4	1		
3-029	990-11040-201	SCREW 4X20	1		
3-030	061-32350-203	THROTTLE LEVER SPRING	1		
3-031	511-32050-200	COLLAR	1	N F098201-	



# FIG.4 RECOIL STARTER

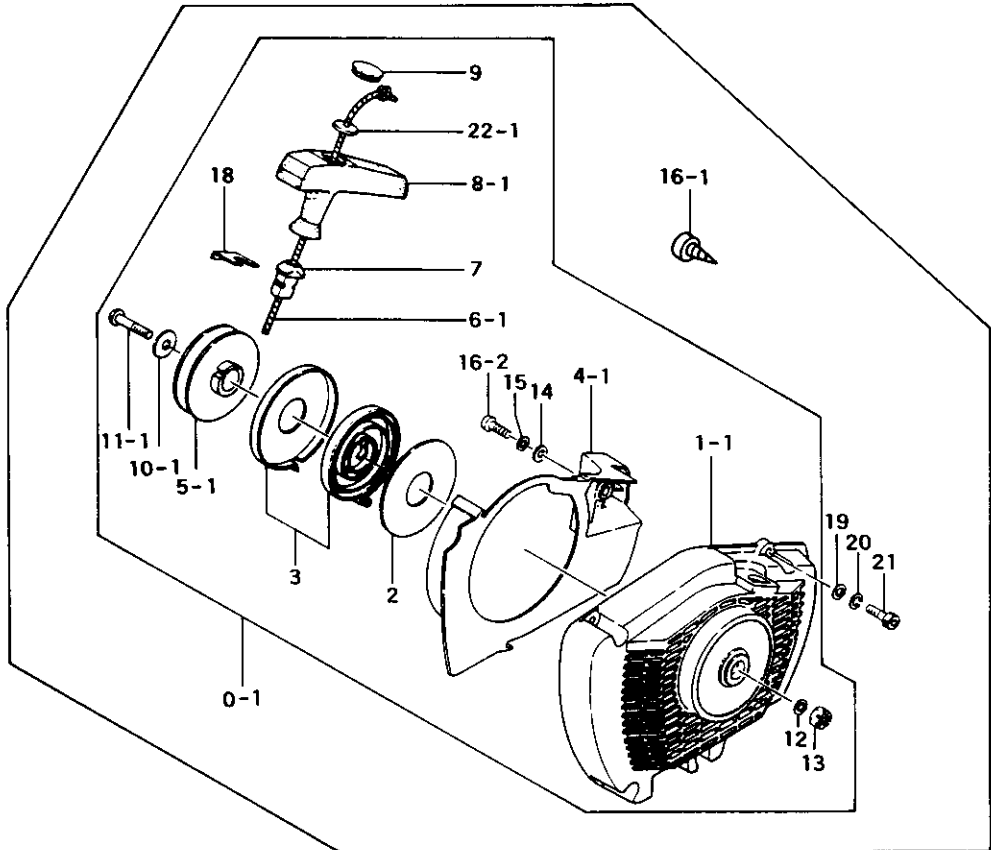
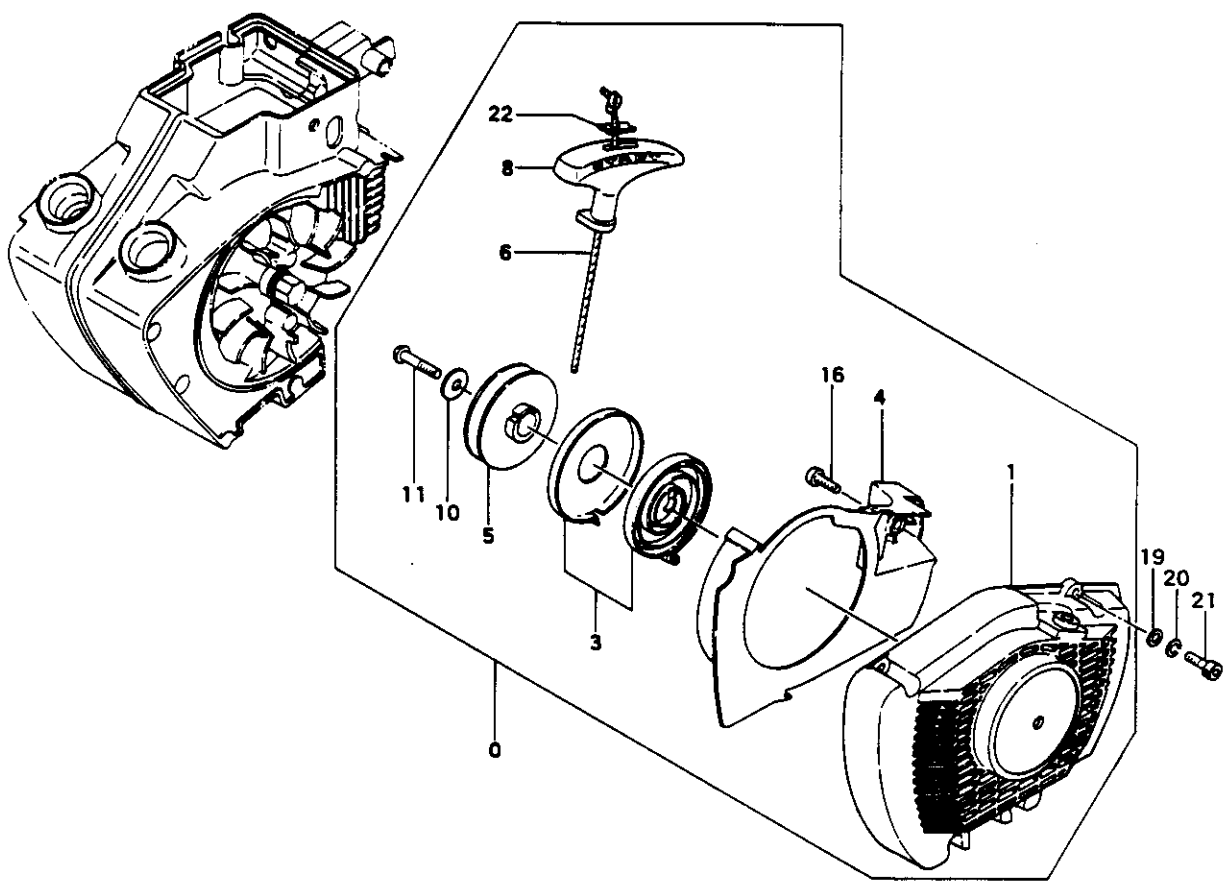

REF. NBR	PART NBR	PART NAME	QTY	SERIAL NBR	REMARKS
4-000.1	756-01801-900	RECOIL STARTER ASS'Y	1	R -C101430	
4-000.1	756-01856-901	RECOIL STARTER ASS'Y	1	R -D164255	
4-000.1	756-01856-902	RECOIL STARTER ASS'Y	1	-F098200	
4-000	756-3236A-900	RECOIL STARTER ASS'Y	1	P F098201-	
4-001.1	112-01801-801	FAN CASE COMP.	1	R -C101430	
4-001.1	112-01856-801	FAN CASE COMP.	1	-F098200	
4-001	112-0181A-800	FAN CASE COMP.	1	N F098201-	
4-002	778-00601-201	RECOIL SPRING CASE COVER	1	-D164255	
4-002	827-04060-210	RECOIL SPRING CASE COVER	1	N D164256-	
4-002	827-04060-210	RECOIL SPRING CASE COVER	1	D F098201-	
4-003	778-00601-900	RECOIL SPRING CASE ASS'Y	1		
4-004.1	145-01850-201	COVER	1	R -C163200	
4-004.1	145-01850-202	COVER	1	-F098200	
4-004	145-01850-203	COVER	1	N F098201-	
4-005.1	774-00601-806	STARTER ROPE REEL COMP.	1	-F098200	
4-005	774-04063-800	STARTER ROPE REEL COMP.	1	N F098201-	
4-006.1	783-01800-200	STARTER ROPE 3.5X960	1	-F098200	
4-006	783-04063-200	STARTER ROPE	1	N F098201-	
4-007	780-11600-201	ROPE GUIDE	1	D F098201-	
4-008.1	785-11600-202	STARTER HANDLE	1	-F098200	
4-008	785-04063-200	STARTER HANDLE	1	N F098201-	
4-009	833-10207-200	STARTER HANDLE CAP	1	D F098201-	
4-010.1	992-08050-006	SPECIAL WASHER 5	1	-F098200	
4-010	786-04063-200	STARTER WASHER	1	N F098201-	
4-011.1	990-11050-271	SCREW 5X27	1	-D035270	
4-011.1	990-11050-251	SCREW 5X25	1	N -F098200	
4-011	990-15050-121	SCREW 5X12	1	N F098201-	
4-012	992-20050-006	INNER TOOTHED WASHER 5	1	N	
4-012	992-20050-010	INNER TOOTHED WASHER 5	1	D F098201-	
4-013	991-20050-011	HEX.SLOTTED NUT	1	D F098201-	
4-014	992-00050-011	SMALL WASHER 5	1	D F098201-	
4-015	992-10050-012	S.WASHER 5	1	M	
4-016.1	993-11052-013	TAPPING SCREW 5X20	1	-C163200	
4-016.2	990-11050-201	SCREW 5X20	1	N -F098200	
4-016	990-18050-181	SCREW 5X18	1	N F098201-	
4-018	781-11600-200	HANDLE GUIDE HOLDER METAL	1	D F098201-	
4-019	992-00050-011	SMALL WASHER 5	4		
4-020	992-10050-012	S.WASHER 5	4		
4-021	990-51050-153	HEX. HOLE BOLT 5X15	4		
4-022.1	795-11600-200	ROPE STOPPER	1	N C155000-	
4-022.1	795-11600-200	ROPE STOPPER	1	-F098200	
4-022	795-04063-200	ROPE STOPPER	1	N F098201-	

# FIG.5 REAR HANDLE

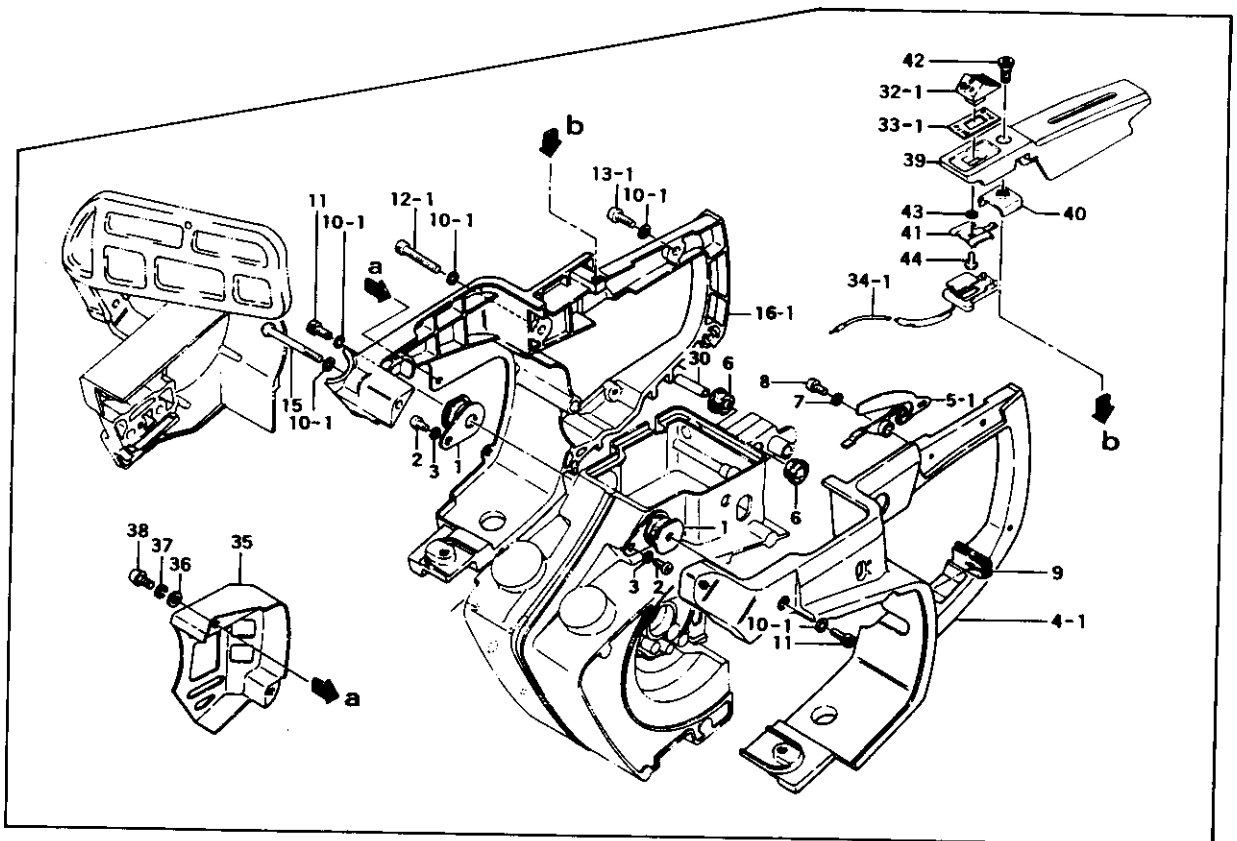
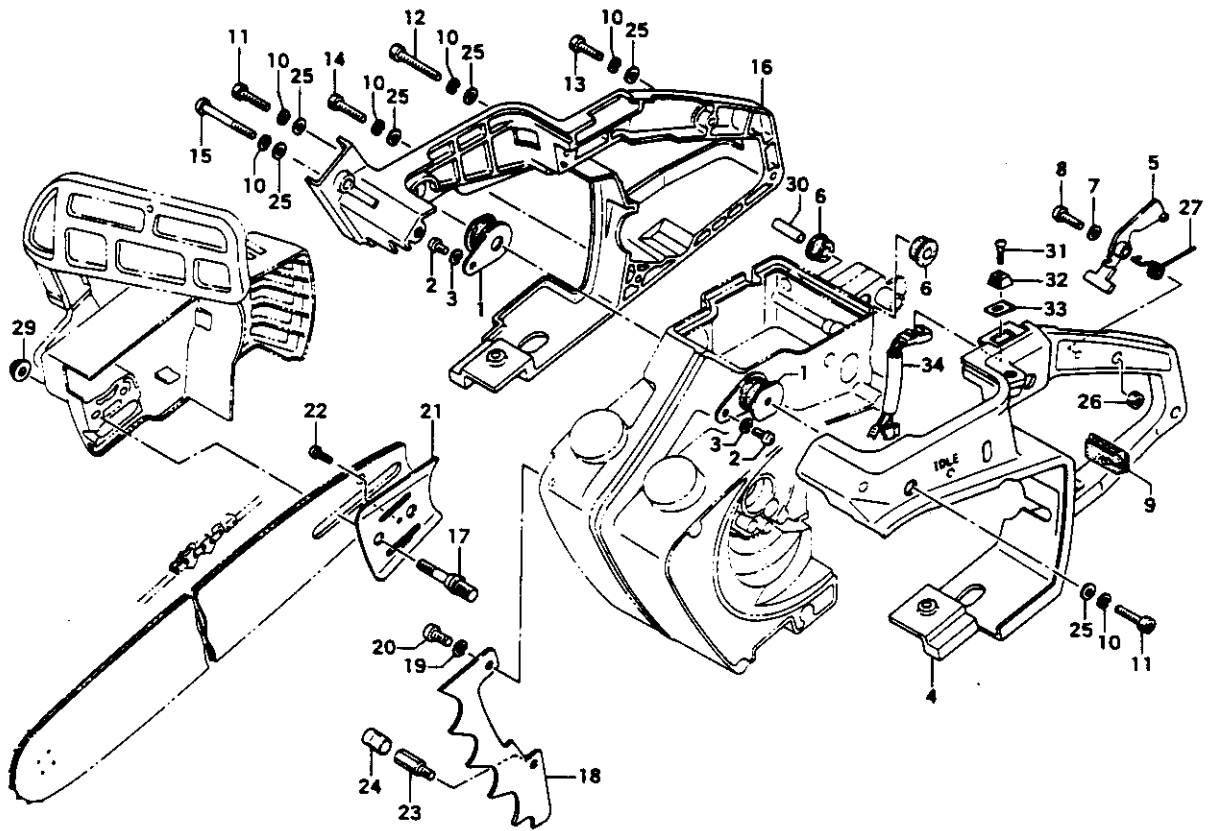

REF. NBR	PART NBR	PART NAME	QTY	SERIAL NBR	REMARKS
5-001	222-32350-801	SIDE DAMPER COMP.	2		
5-002	990-11050-121	SCREW 5X12	2		
5-003	992-10050-012	S. WASHER 5	2		
5-004, 1	010-32353-201	HANDLE/REAR A	1	-F098200	
5-004	010-3236A-800	REAR HANDLE A COMP.	1	N F098201-	
5-005, 1	257-32350-212	SAFTY LEVER	1	-F098200	
5-005	257-32050-202	SAFETY LEVER	1	N F098201-	
5-006	250-32350-201	SAFETY DAMPER	2		
5-007	992-01030-011	WASHER 3	1		
5-008	990-11030-081	SCREW 3X8	1	-E155100	
5-008	990-11030-101	SCREW 3X10	1	N -F098200	
5-008	990-11030-081	SCREW 3X8	1	N F098201-	
5-009	202-01800-201	SECONDARY CORD GROMMET	1	-C163100	
5-009	202-01800-202	SECONDARY CORD GROMMET	1	P C163101-	
5-010, 1	992-10050-012	S. WASHER 5	5	-F098200	
5-010	992-10050-012	S. WASHER 5	7	F098201-	
5-011	990-51050-153	HEX. HOLE BOLT 5X15	2		
5-012, 1	990-51050-353	HEX. HOLE BOLT 5X35	1	-F098200	
5-012	990-51050-403	HEX. HOLE BOLT 5X40	1	N F098201-	
5-013, 1	990-11050-161	SCREW 5X16	1	-F098200	
5-013	990-51050-203	HEX. HOLE BOLT 5X20	2	N F098201-	
5-014	990-51050-303	HEX. HOLE BOLT 5X30	1	N F098201-	
5-015	990-11050-451	SCREW 5X45	1		
5-016, 1	011-32353-202	REAR HANDLE B	1	R -D209450	
5-016, 1	011-32371-202	REAR HANDLE B	1	-F098200	
5-016	011-3236A-800	REAR HANDLE B COMP.	1	N F098201-	
5-017	101-32350-200	CHAIN BAR CLAMP BOLT	2		
5-018	460-32350-210	SPIKE	1		
5-019	992-10050-012	S. WASHER 5	1		
5-020	990-11050-121	SCREW 5X12	1		
5-021	461-32350-210	GUIDE PLATE A	1		
5-022	990-11040-061	SCREW 4X6	1		
5-023	125-32060-210	CHAIN CATCHER	1		
5-024	700-01012-018	VINYL PIPE	1		
5-025	992-00050-011	SMALL WASHER 5	7	N F098201-	
5-026	991-01050-011	HEX. NUT 5	4	N F098201-	
5-027	258-32050-200	SAFETY SPRING	1	N F098201-	
5-029	121-32350-200	CHAIN BAR CLAMP NUT	2		
5-030	251-32350-200	SAFETY DAMPER COLLAR	1		
5-031	994-31030-101	SCREW 3X10	1	N F098201-	
5-032, 1	258-04015-202	STOP BUTTON	1	-F098200	
5-032	258-11600-200	BUTTON STOP	1	N F098201-	
5-033, 1	925-32350-200	ON-OFF MARK	1	-F098200	
5-033	925-32600-200	STOP BUTTON MARK	1	N F098201-	
5-034, 1	178-01800-803	STOP CORD COMP.	1	R -C189752	
5-034, 1	178-01800-804	STOP CORD COMP.	1	-F098200	
5-034	170-04064-800	STOP BUTTON COMP.	1	N F098201-	
5-035	738-32371-200	MUFFLER PROTECTOR	1	D D164256-	
5-036	992-00050-011	SMALL WASHER 5	2	D D164256-	
5-037	992-10050-012	S. WASHER 5	2	D D164256-	
5-038	990-11050-101	SCREW 5X10	2	D D164256-	
5-039	226-32350-202	HANDLE GRIP B	1	D F098201-	
5-040	272-04015-204	GROUND TERMINAL	1	D F098201-	
5-041	261-01800-201	STOP BUTTON TERMINAL	1	D F098201-	
5-042	990-12050-151	F.H. SCREW 5X15	1	-E155100	
5-042	990-12050-121	F.H. SCREW 5X12	1	N E155101-	
5-042	990-12050-121	F.H. SCREW 5X12	1	D F098201-	
5-043	992-00040-011	SMALL WASHER 4	1	D F098201-	
5-044	990-11040-061	SCREW 4X6	1	D F098201-	

# FIG.6 HANDLE

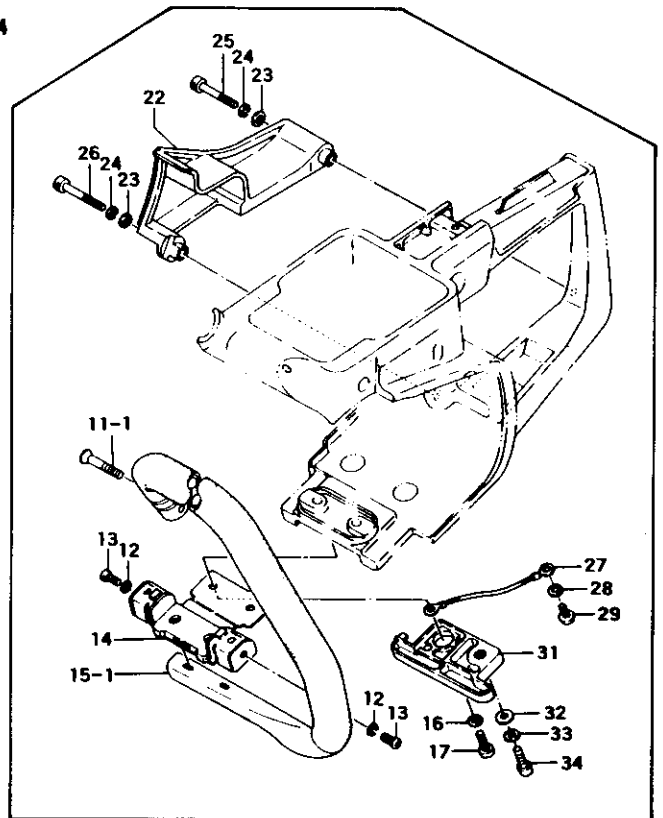
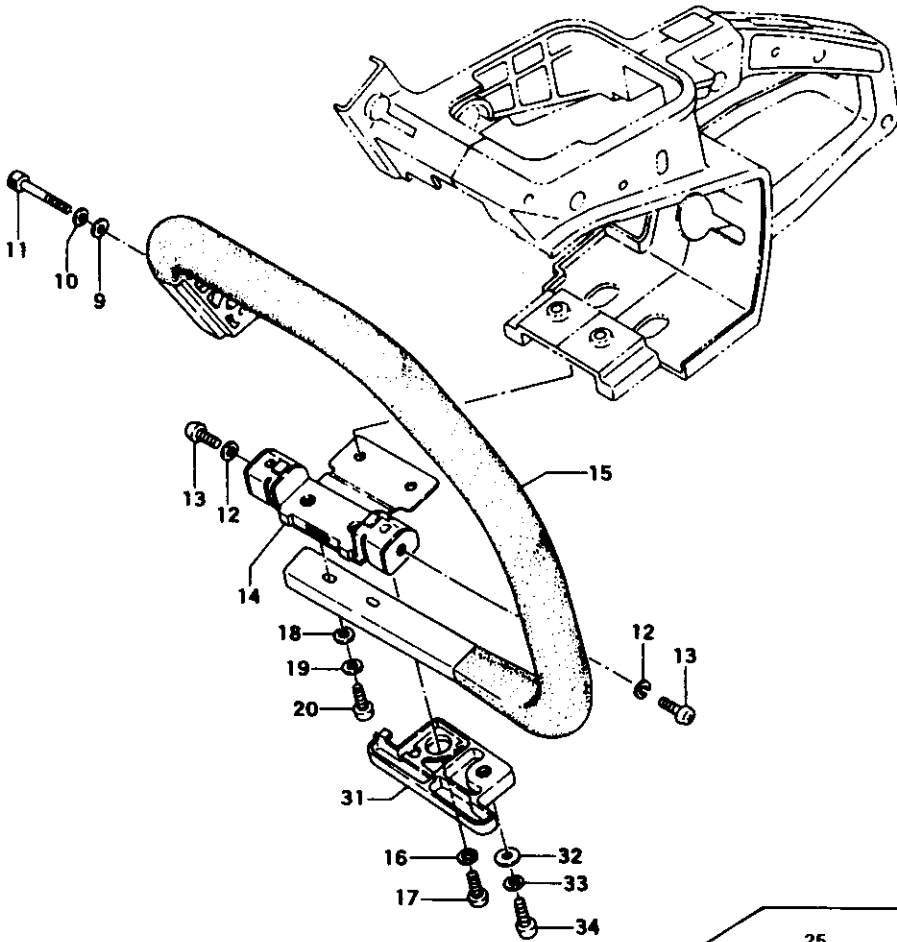

REF. NBR	PART NBR	PART NAME	QTY	SERIAL NBR	REMARKS
6-009	992-00050-011	SMALL WASHER 5	2 N	F098201-	
6-010	992-10050-012	S.WASHER 5	2 N	F098201-	
6-011, 1	990-13050-251	SCREW 5X25	1	-F098200	
6-011	990-51050-253	HEX. HOLE BOLT 5X25	2 N	F098201-	
6-012	992-10050-012	S.WASHER 5	2		
6-013	990-11050-121	SCREW 5X12	2		
6-014	219-32350-804	DAMPER FRONT COMP.	1		
6-015, 1	209-32371-800	FRONT HANDLE COMP.	1	-F098200	
6-015	209-3236A-800	FRONT HANDLE COMP.	1 N	F098201-	
6-016	992-10050-012	S.WASHER 5	1 N	C101431-	
6-017	990-11050-121	SCREW 5X12	1		
6-018	992-01050-011	WASHER 5	2		
6-019	992-10050-012	S.WASHER 5	2		
6-020	990-11050-161	SCREW 5X16	2		
6-022	800-32350-801	REAR HAND GUARD	1 I	-E155100	
6-022	800-32350-802	REAR HAND GUARD	1	E155101-	
6-022	800-32350-802	REAR HAND GUARD	1 D	F098201-	
6-023	992-00050-011	SMALL WASHER 5	2 D	F098201-	
6-024	992-10050-012	S.WASHER 5	2 D	F098201-	
6-025	990-51050-303	HEX. HOLE BOLT 5X30	1 D	F098201-	
6-026	990-51050-403	HEX. HOLE BOLT 5X40	1 D	F098201-	
6-027	274-01800-800	GROUND CORD COMP.	1 D	F098201-	
6-028	992-10050-012	S.WASHER 5	1 D	F098201-	
6-029	990-11050-101	SCREW 5X10	1 D	F098201-	
6-031	797-32050-800	EARTH CORD COVER	1 N	C101431-	
6-032	992-00050-011	SMALL WASHER 5	1 I	-C170669	
6-032	992-01050-011	WASHER 5	1	C170670-	
6-033	992-10050-012	S.WASHER 5	1		
6-034	990-11050-121	SCREW 5X12	1	-C101430	
6-034	990-11050-161	SCREW 5X16	1 N	C101431-	

# FIG.7 OIL PUMP

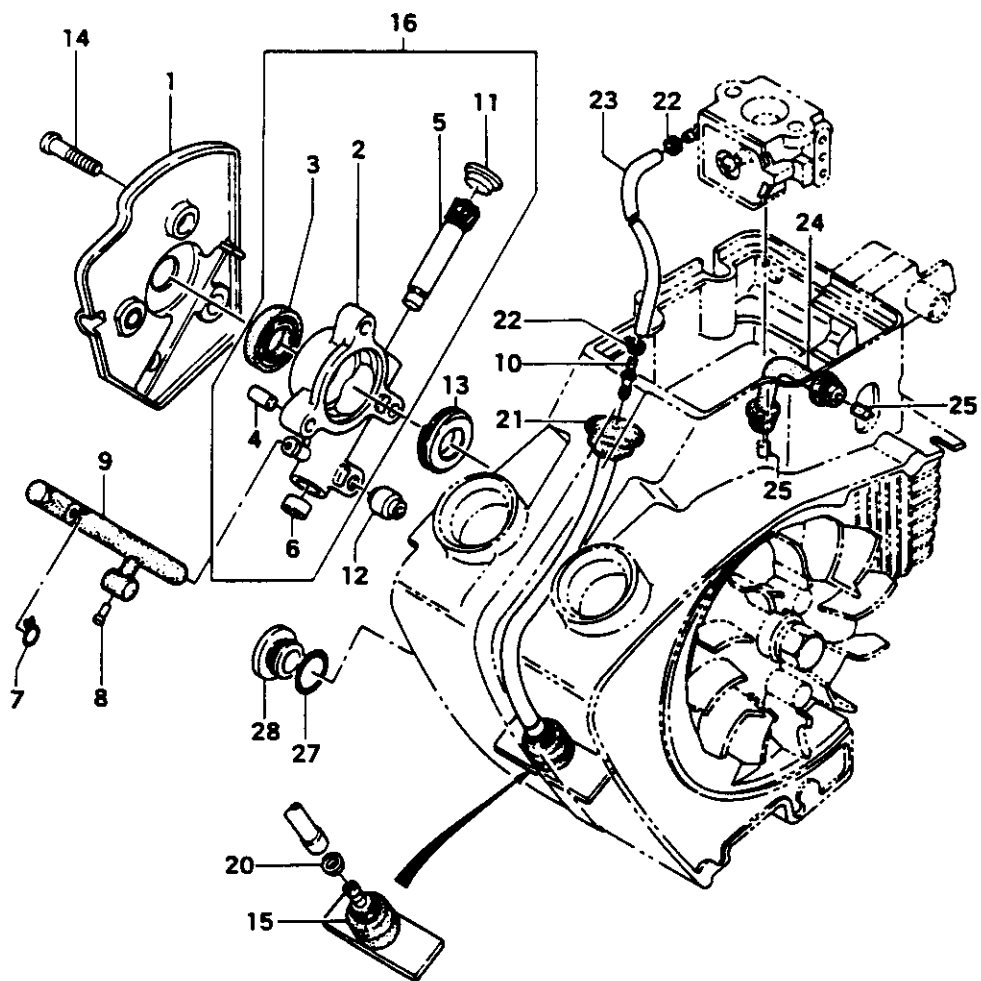

REF. NBR	PART NBR	PART NAME	QTY	SERIAL NBR	REMARKS
7-001	097-32350-801	OIL PUMP SHROUD COMP.	1		
7-002	088-32350-800	OIL PUMP CASE COMP.	1		
7-003	999-66132-420	OIL SEAL AC13246	1		
7-004	999-05040-800	KNOCK PIN 4X8	1		
7-005	085-32350-200	PUMP GEAR	1	R -D164255	
7-005	085-32350-201	PUMP GEAR	1	D164256-	
7-006	086-32350-211	GROMMET A	1		
7-007	680-03113-200	CLIP 7.5	1		
7-008	516-32350-201	OIL JET	1		
7-009	515-32350-201	OIL PIPE A	1		
7-010	497-32350-200	PIPE JOINT	1		
7-011	053-32500-201	GROMMET B	1		
7-012	622-00604-200	AIR PIPE	1	R -D164255	
7-012	622-00604-201	AIR PIPE	1	R -E314140	
7-012	428-32350-200	JOINT RUBBER	1	E314141-	
7-013	084-32350-200	SCREW GEAR	1		
7-014	990-11050-221	SCREW 5X22	3		
7-015	675-01801-900	PUMP FILTER BODY ASS'Y	1	I -D217300	
7-015	675-01801-901	PUMP FILTER BODY ASS'Y	1	D217301-	
7-016	088-32350-900	OIL PUMP CASE ASS'Y	1	R -D164255	
7-016	088-32350-901	OIL PUMP CASE ASS'Y	1	D164256-	
7-020	680-04019-210	CLIP 7	1		
7-021	678-32350-200	RUBBER PIPE/SUCTION	1		
7-022	680-00206-200	CLIP 5.5	2		
7-023	700-13005-060	FUEL PIPE	1	R -D164255	
7-023	700-13005-055	FUEL PIPE	1	D164256-	
7-024	565-01800-202	AIR VENT PIPE	1		
7-025	567-01800-200	AIR VENT SPONGE	2		
7-027	999-67012-500	O-RING P12.5	1		
7-028	525-32350-201	OIL LEVEL CAP	1		



# FIG.8 CARBURETOR

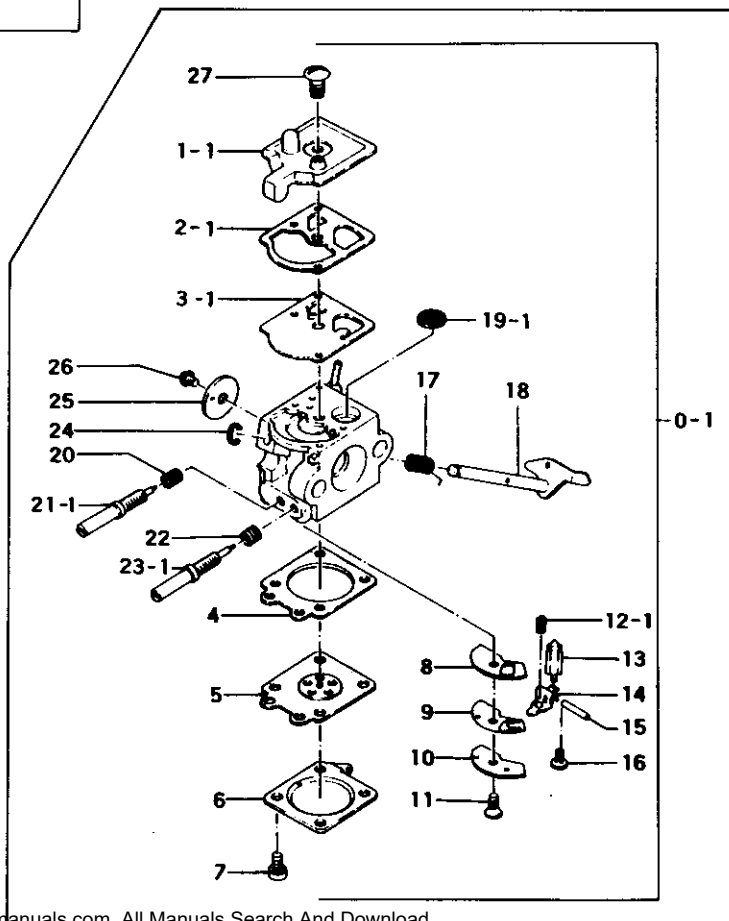
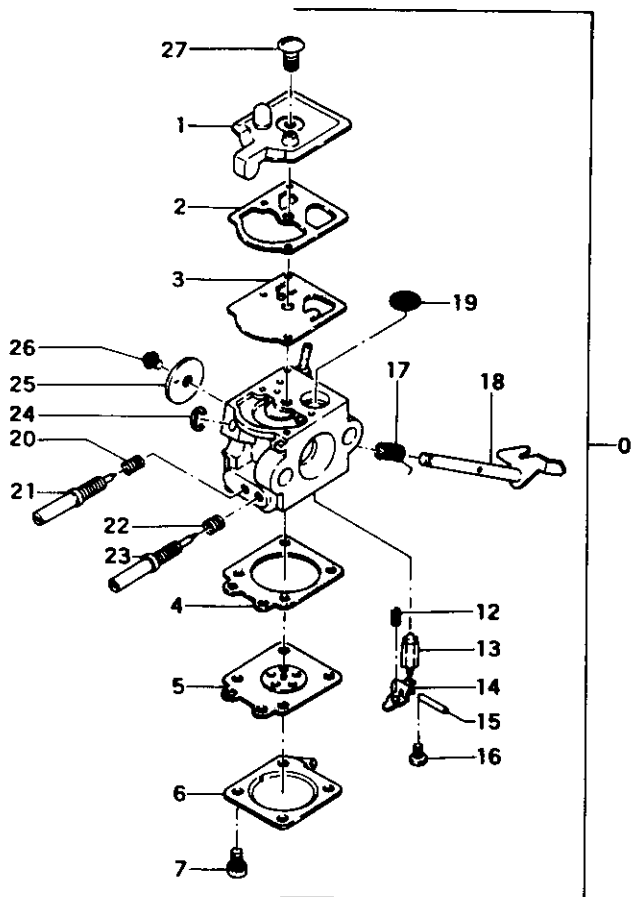

REF. NBR	PART NBR	PART NAME	QTY		SERIAL NBR	REMARKS
8-000.1	455-25005-901	CARBURETOR ASS'Y	1	R	-E155100	
8-000	455-25024-900	CARBURETOR ASS'Y	1		E155101-	
8-001.1	575-25005-200	PUMP BODY	1		-E155100	
8-001	575-25024-200	PUMP BODY	1	N	E155101-	
8-002.1	577-25001-200	PUMP GASKET	1		-E155100	
8-002	577-25007-200	PUMP GASKET	1	N	E155101-	
8-003.1	576-25001-200	PUMP DIAPHRAGM	1		-E155100	
8-003	576-25006-200	PUMP DIAPHRAGM	1	N	E155101-	
8-004	475-25001-200	DIAPHRAGM GASKET	1			
8-005	474-25001-800	METERING DIAPHRAGM COMP.	1			
8-006	476-25003-200	DIAPHRAGM CASE	1			
8-007	548-25012-200	SET SCREW	4			
8-008	522-25001-200	CIRCUIT PLATE GASKET	1	D	E155101-	
8-009	521-25001-200	CIRCUIT CHECK VALVE DIAPHRAGM	1	D	E155101-	
8-010	523-25001-200	CIRCUIT PLATE	1	D	E155101-	
8-011	524-25001-200	CIRCUIT PLATE SCREW	1	D	E155101-	
8-012.1	477-25003-200	VALVE SPRING	1		-E155100	
8-012	477-25007-200	VALVE SPRING	1	N	E155101-	
8-013	603-25001-200	NEEDLE VALVE	1			
8-014	473-25001-200	VALVE HINGE	1			
8-015	605-25001-200	HINGE PIN	1			
8-016	546-25001-200	HINGE PIN SET SCREW	1			
8-017	486-25005-200	THROTTLE SPRING	1			
8-018	464-25003-801	THROTTLE SHAFT COMP.	1			
8-019.1	578-25001-200	INLET SCREEN	1	R	-E155100	
8-019	578-25007-200	INLET SCREEN	1		E155101-	
8-020	623-25001-200	HIGH/LOW ADJUST SPRING	1			
8-021.1	461-25005-200	LOW ADJUST SCREW	1		-E155100	
8-021	461-25016-200	LOW ADJUST SCREW	1	N	E155101-	
8-022	485-25003-200	HIGH ADJUST SPRING	1			
8-023.1	460-25003-200	MAIN ADJUST SCREW	1		-E155100	
8-023	460-25016-200	HIGH ADJUST SCREW	1	N	E155101-	
8-024	489-25004-200	STOP RING	1			
8-025	488-25001-200	THROTTLE VALVE	1			
8-026	467-25003-200	SHUTTER SCREW	1			
8-027	514-25001-200	SET SCREW	1			

# FIG.9 TOOLS

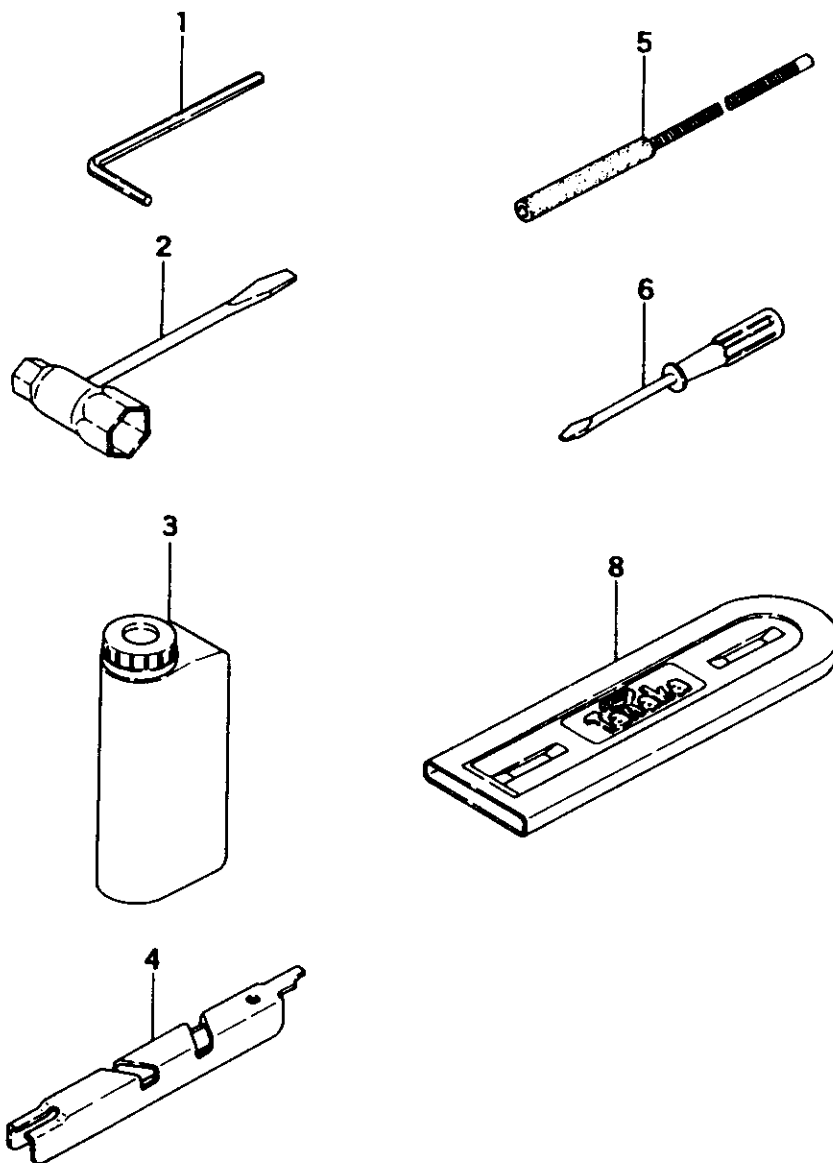

REF. NBR	PART NBR	PART NAME	QTY	SERIAL NBR	REMARKS
9-001	813-20000-200	HEX. WRENCH 4	1		
9-002	013-29323-500	COMBI. BOX SPANNER 10X19	1	R -D164255	
9-002	013-29323-501	COMBI. BOX SPANNER 10X19	1	D164256-	
9-003	872-20000-201	FUEL PREMIX CANISTER	1		
9-004	930-32057-200	DEPTH GAUGE	1		
9-005	936-20000-900	FILE ASS'Y 5/32"	1		
9-006	864-20000-210	MINUS DRIVER 2.8X40	1		
9-008	947-32055-200	CHAIN COVER 16"	1	R -C162900	
9-008	947-32055-201	CHAIN COVER 16"	1	C162901-	

# FIG.10 MARKS

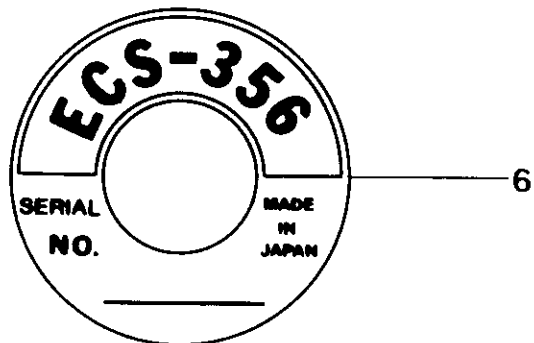
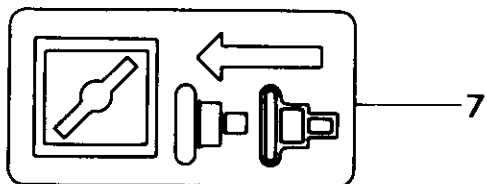
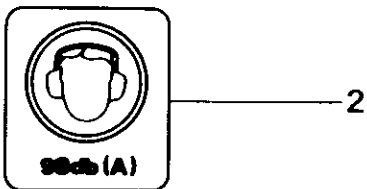
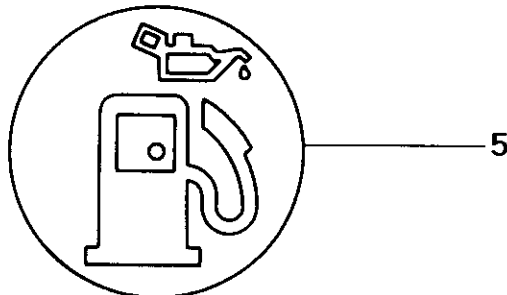
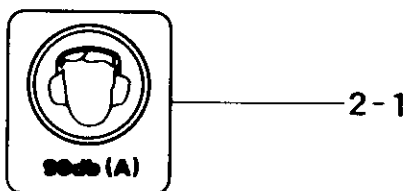
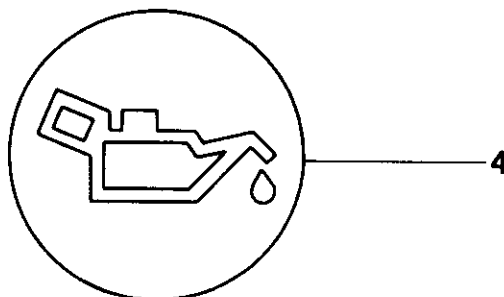
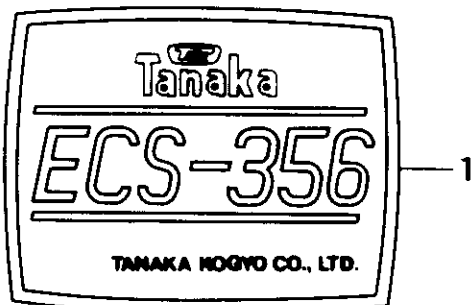
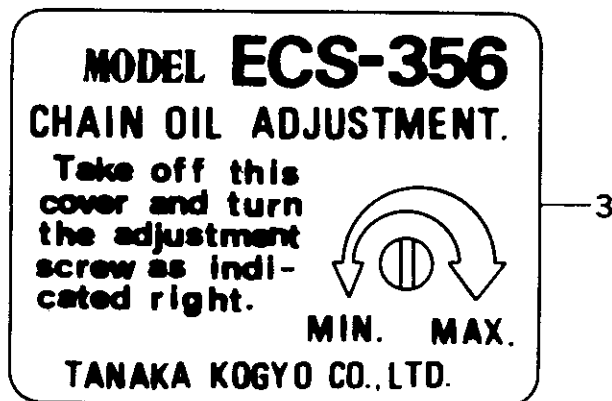
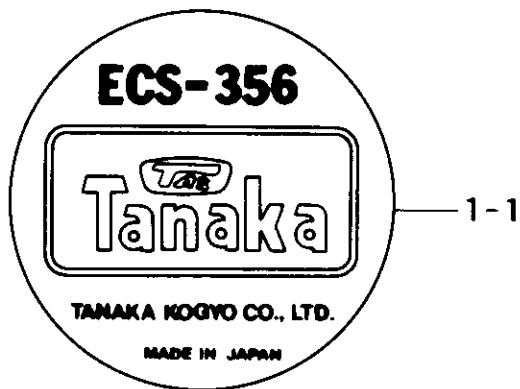

REF. NBR	PART NBR	PART NAME	QTY	SERIAL NBR	REMARKS
10-001.1	906-32371-210	NAME PLATE	1	-D150277	
10-001	906-32399-200	NAME PLATE	1	N D150278-	
10-002.1	931-32377-201	EARMUFF CARE MARK	1	I -E155100	
10-002	931-32378-200	EARMUFF CARE MARK	1	E155101-	
10-003	912-32371-210	CLEANER COVER MARK	1		
10-004	921-32350-201	OIL MARK	1		
10-005	920-32600-210	FUEL MARK	1		
10-006	915-32371-210	STARTER MARK	1		ECS-356
10-007	913-32377-200	CHOKE MARK	1	D F098201-	

## Free Manuals Download Website

<http://myh66.com>

<http://usermanuals.us>

<http://www.somanuals.com>

<http://www.4manuals.cc>

<http://www.manual-lib.com>

<http://www.404manual.com>

<http://www.luxmanual.com>

<http://aubethermostatmanual.com>

Golf course search by state

<http://golfingnear.com>

Email search by domain

<http://emailbydomain.com>

Auto manuals search

<http://auto.somanuals.com>

TV manuals search

<http://tv.somanuals.com>