

SPARE PARTS CATALOGUE

CHAIN SAW

MODEL

ECS-370

SERIAL No. D I 70955

The logo features the letters 'TAS' in a stylized font inside a dark oval, positioned above the word 'Tanaka' in a bold, sans-serif typeface.

4M20 (STD)

FIG.1 ENGINE

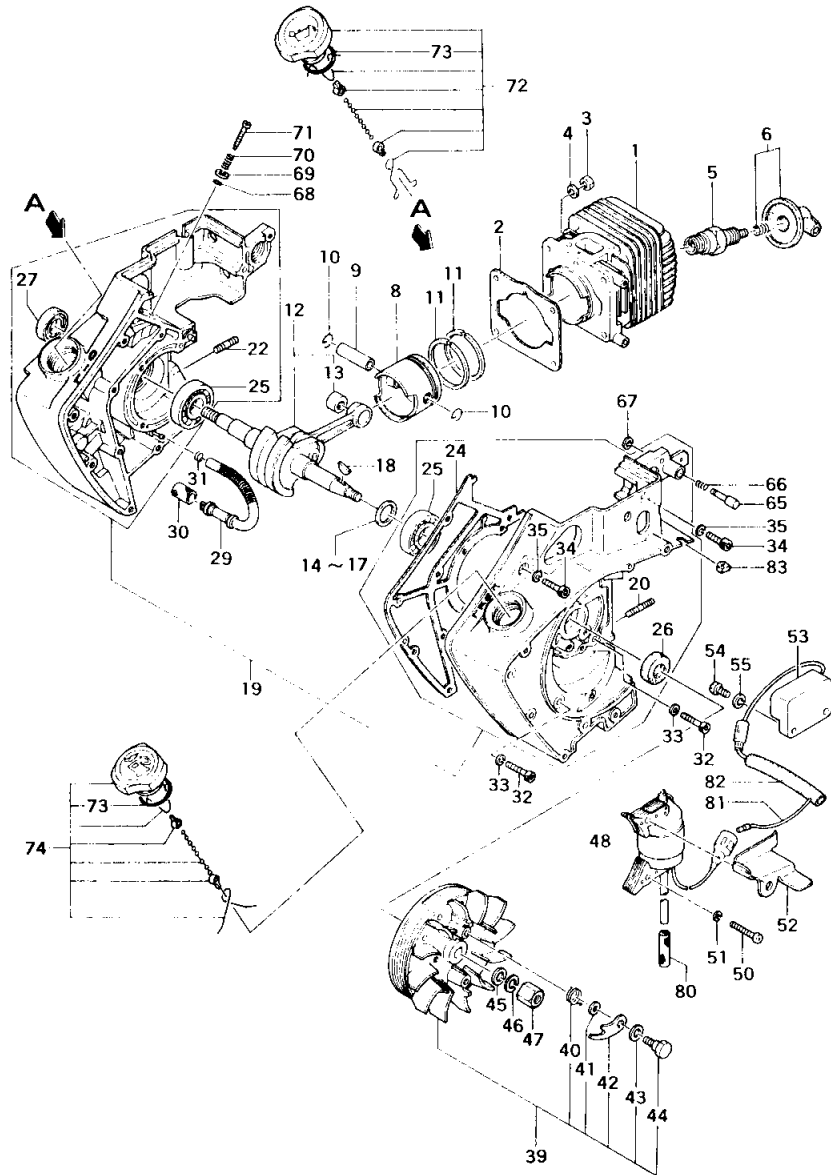

REFERENCE NUMBER	PRODUCTION PART NUMBER	PART NAME	QUANTITY	SERIAL NUMBER	SPARE PART NUMBER
FIG.1 ENGINE					
1-001	002-01850-204	CYLINDER	1	002 0322	5
1-002	017-01800-200	CYLINDER GASKET	1	017 0080	8
1-003	991-01050-011	HEX. NUT 5	4	991 0015	5
1-004	992-10050-012	S.WASHER 5	4	992 1012	4
1-005	018-11600-200	SPARK PLUG BM-7A	1	018 0250	0
1-006	157-01800-901	SPARK PLUG CAP ASS'Y	1	157 0020	9
1-008	031-01850-200	PISTON	1	031 0580	7
1-009	037-01400-200	PISTON PIN	1	037 0030	9
1-010	039-00000-201	PISTON PIN CIRCLIP	2	039 0000	2
1-011	041-04000-200	PISTON RING	2	041 0050	4
1-012	046-01850-800	CRANKSHAFT COMP.	1	046 0330	4

FIG.1 ENGINE

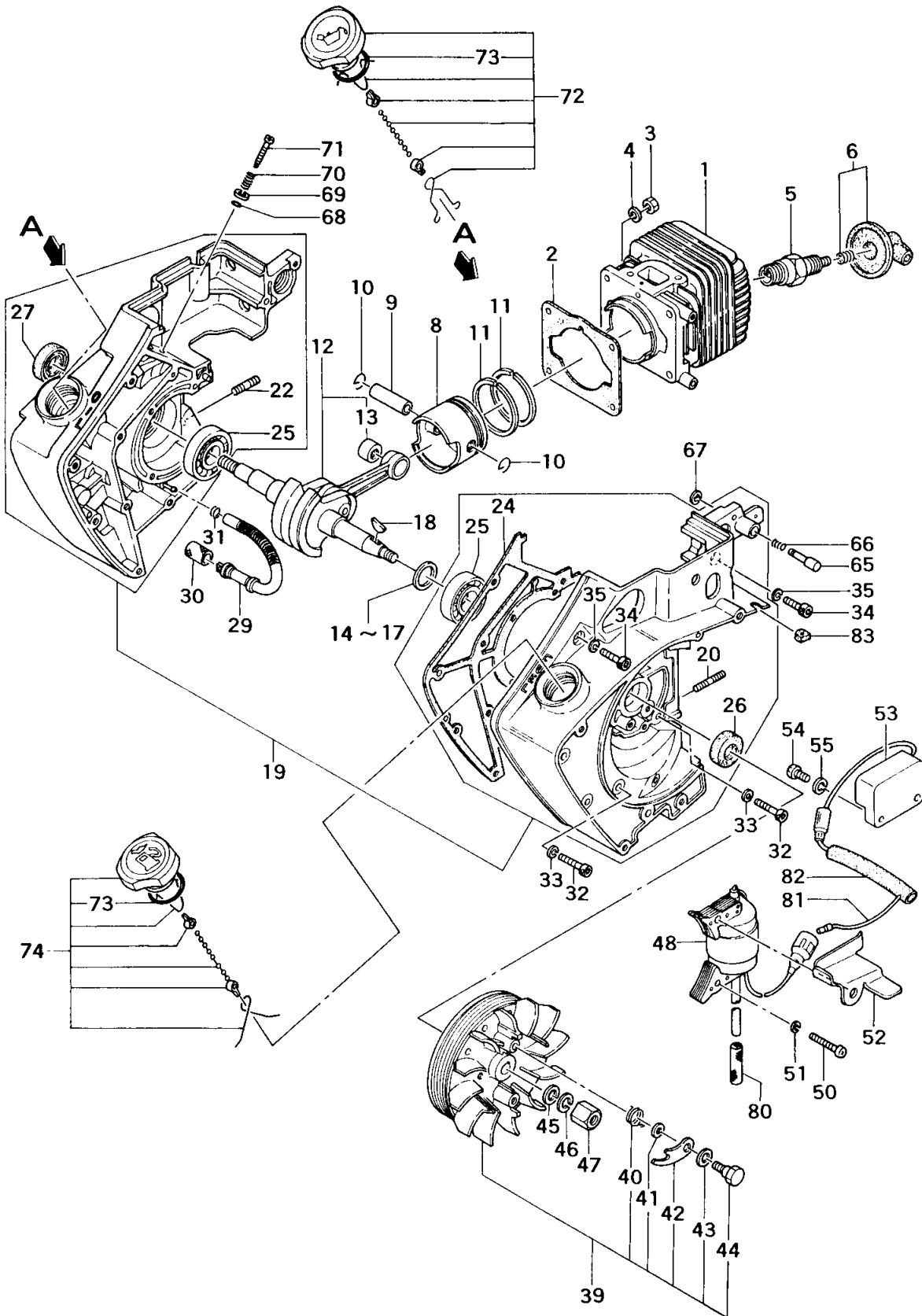

REFERENCE NUMBER	PRODUCTION NUMBER	PART NAME	QUANTITY	SERIAL NUMBER	SPARE PART NUMBER
FIG.1 ENGINE					
1-013	999-62091-325	NEEDLE BEARING F-910	1		999 6207 2
1-014	071-02007-200	CRANK SHAFT SHIM 0.05	V		071 0040 6
1-015	071-02007-210	CRANK SHAFT SHIM 0.10	V		071 0041 5
1-016	071-02007-220	CRANK SHAFT SHIM 0.15	V		071 0042 4
1-017	071-02007-230	CRANK SHAFT SHIM 0.20	V		071 0043 3
1-018	068-10100-200	WOOD-RUFF KEY 3X13X4.5	1		068 0060 6
1-019	072-01850-901	CRANK CASE ASS'Y	1		072 0080 1
1-020	100-00501-200	STUD BOLT 5X26	2		100 0020 5
1-022	100-00100-201	STUD BOLT 5X21	2		100 0000 1
1-024	090-01800-203	CRANK CASE GASKET	1		090 0112 5
1-025	999-61620-200	BALL BEARING #6202	2		999 6139 8
1-026	999-66122-200	OIL SEAL TB12227	1		999 6609 2
1-027	999-66152-500	OIL SEAL 15257	1		999 6622 3
1-029	505-32350-203	OIL PIPE B	1		505 0062 0
1-030	510-32350-200	FILTER NET	1		510 0120 5
1-031	680-00803-202	CLIP	1		680 0091 2
1-032	990-51050-253	HEX. HOLE BOLT 5X25	10		990 5014 4
1-033	992-10050-012	S.WASHER 5	10		992 1012 4
1-034	990-51050-223	HEX. HOLE BOLT 5X22	2		990 5011 7
1-035	992-10050-012	S.WASHER 5	2		992 1012 4
1-039	155-20731-900	MAGNETO ROTOR ASS'Y	1	B045745	155 0360 2
1-039	155-21704-911	MAGNETO ROTOR ASS'Y	1	B045746-	155 0781 7
1-040	790-01800-200	STARTER PAWL SPRING	2		790 0040 2
1-041	786-00601-200	STARTER PAWL WASHER	2		786 0000 3
1-042	788-00601-203	STARTER PAWL	2		788 0010 4
1-043	822-01006-200	STARTER PAWL SHIM 0.35T	2	-C207933	822 0010 5
1-043	822-00601-200	STARTER PAWL SHIM 0.6T	2	C207934-	822 0000 8
1-044	793-10200-200	STEP BOLT	2		793 0030 6
1-045	065-00000-200	FLYWHEEL WASHER	1		065 0000 3
1-046	992-10070-012	S.WASHER 7	1		992 1024 9
1-047	066-01800-200	FLYWHEEL NUT	1		066 0050 5
1-048	167-20763-800	IGNITION COIL COMP.	1		167 0770 8
1-050	990-11040-181	SCREW 4X18	2		990 1042 1
1-051	992-10040-012	S.WASHER 4	2		992 1007 2
1-052	198-01800-230	CORD CLAMP	1		198 0165 4
1-053	159-21401-871	IGNITOR TTI-1E	1		159 0372 5
1-054	990-11040-161	SCREW 4X16	2		990 1040 3
1-055	992-10040-012	S.WASHER 4	2		992 1007 2
1-065	064-32300-201	PUSH PIN	1		064 0050 1
1-066	066-32300-201	STOPPER SPRING	1		066 0420 6
1-067	791-00100-200	STOP RING 3	1		791 0000 1
1-068	999-67003-000	O-RING P3	1		999 6701 3
1-069	992-01040-011	WASHER 4	1		992 0031 0
1-070	502-32302-200	ADJUSTER SPRING	1		502 0090 2
1-071	501-32350-201	OIL PUMP ADJUSTER	1		501 0110 2
1-072	624-32350-901	OIL TANK CAP ASS'Y	1		624 0021 3
1-073	999-67022-000	O-RING P22	2		999 6723 5
1-074	635-32377-901	FUEL TANK CAP ASS'Y	1		635 0110 0
1-080	755-32050-200	CORD INSULATOR TUBE	1	A312061-	755 0000 7
1-081	178-00610-801	STOP CORD COMP.	1		178 0110 8
1-082	203-01800-200	CORD GROMMET	1		203 0040 1
1-083	203-06000-200	PRIMARY CORD GROMMET	1		203 0090 6

FIG.2 CLUTCH & BRAKE

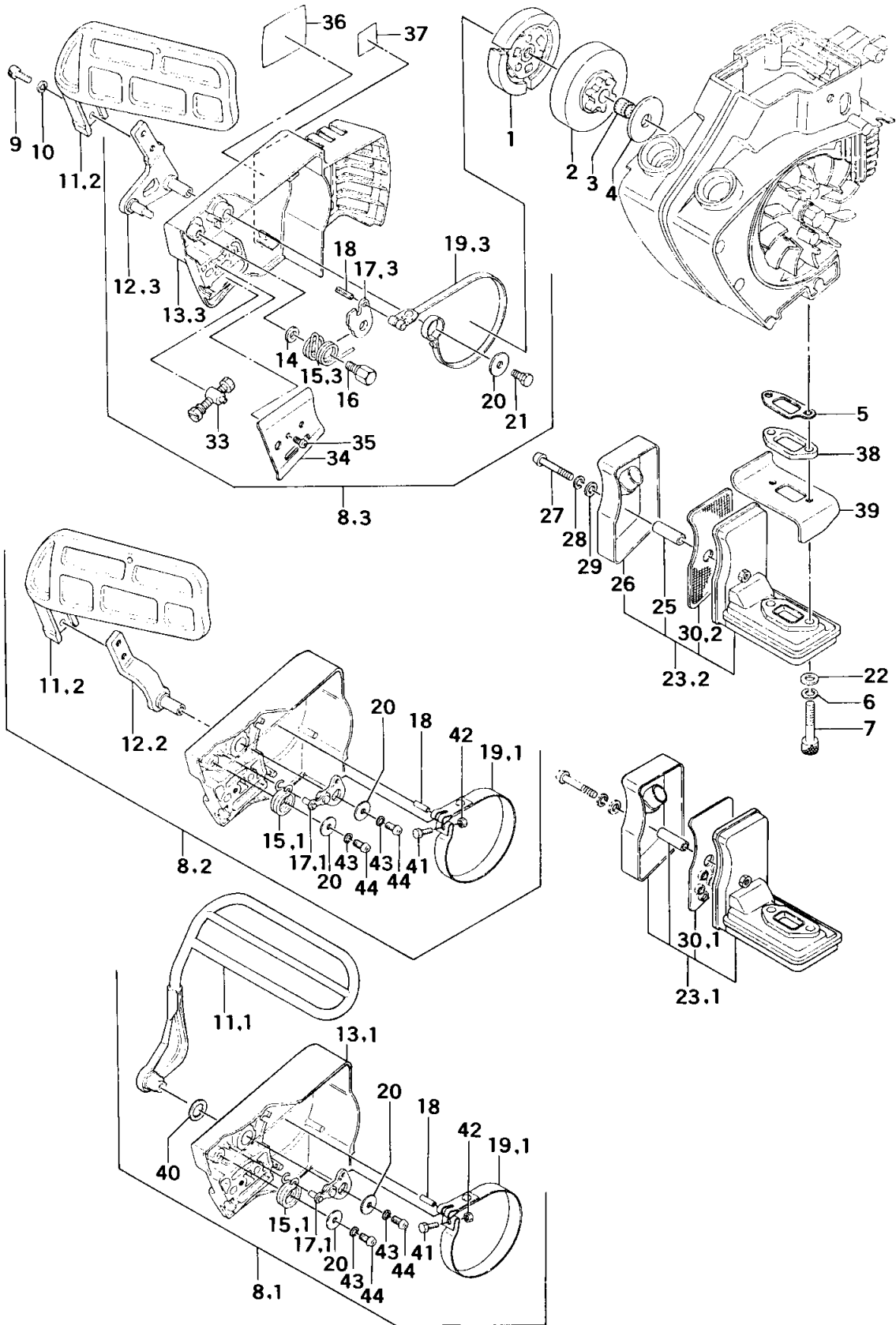

REFERENCE NUMBER	PRODUCTION PART NUMBER	PART NAME	QUANTITY	SERIAL NUMBER	SPARE PART NUMBER
FIG.2 CLUTCH & BRAKE					
2-001	287-01801-800	CLUTCH COMP.	1		287 0010 2
2-002	310-01800-811	CLUTCH HOUSING COMP. 1/4	1		310 0021 9
2-002	310-01801-801	CLUTCH HOUSING COMP. 3/8	1		310 0030 7
2-003	999-62101-301	NEEDLE BEARING 101310	1		999 6210 6
2-004	358-01800-200	CLUTCH WASHER	1		358 0000 4
2-005	737-01800-200	MUFFLER GASKET	1		737 0140 6
2-006	992-10060-012	S.WASHER 6	2		992 1019 7
2-007	990-51060-353	HEX. HOLE BOLT 6X35	2	-D170255	990 5025 0
2-007	990-51060-403	HEX. HOLE BOLT 6X40	2	D170256-	990 5036 6
2-008,1	040-32055-910	SIDE CASE ASS'Y	1	-C117547	040 0391 3
2-008,2	040-32056-901	SIDE CASE ASS'Y	1	-D170256	040 0480 0
2-008,3	040-32055-921	SIDE CASE ASS'Y	1	D170256-	040 0392 2
2-009	990-51050-083	HEX. HOLE BOLT 5X8	2	-B207633	990 5002 9
2-009	990-51050-103	HEX. HOLE BOLT 5X10	2	B207634-	990 5003 8
2-010	992-10050-012	S.WASHER 5	2		992 1012 4
2-011,1	380-32351-802	BRAKE HANDLE COMP.	1	-B172678	380 0050 2
2-011,2	380-32600-803	BRAKE HANDLE COMP.	1	B172679-	380 0070 6
2-012,2	361-32377-802	BRAKE LEVER COMP.	1	-D170255	361 0050 3
2-012,3	361-32367-810	BRAKE LEVER COMP.	1	D170256-	361 0031 8
2-013,1	040-32050-213	SIDE CASE	1	-C117547	040 0201 7
2-013,3	040-32055-221	SIDE CASE	1	C117548-	040 0372 8
2-014	871-32367-200	SPECIAL WASHER B	1		871 0030 7
2-015,1	374-32350-210	BRAKE SPRING	1	-B172678	374 0181 0
2-015,3	374-32367-210	BRAKE SPRING	1		374 0191 7
2-016	382-32367-210	STEP BOLT A	1		382 0031 1
2-017,1	379-32350-800	BRAKE LINK COMP.	1	-B172678	379 0040 5
2-017,3	373-32367-201	BRAKE ARM	1	B172679-	373 0100 8
2-018	993-24040-120	SPRING PIN 4X12	1		993 2015 7
2-019,1	378-32350-800	BRAKE BAND COMP.	1	-B172678	378 0050 5
2-019,3	378-32367-820	BRAKE BAND COMP.	1	B172679-	378 0062 0
2-020	368-32350-200	BRAKE SHAFT WASHER	1	-B172678	368 0050 2
2-020	368-32057-200	BRAKE SHAFT WASHER	1	B172679-	368 0120 4
2-021	383-32367-210	STEP BOLT B	1	C154795-	383 0181 6
2-022	992-01060-011	WASHER 6	2		992 0040 8
2-023,1	705-01800-921	MUFFLER ASS'Y	1		705 0312 6
2-023,2	705-01802-930	MUFFLER ASS'Y W/SPARK ARRESTER	1		705 0324 1
2-025	740-01802-200	MUFFLER COLLAR	1		740 0080 5
2-026	717-01800-820	MUFFLER BODY B COMP.	1		717 0331 8
2-027	990-11050-351	SCREW 5X35	1		990 1090 8
2-028	992-10050-012	S.WASHER 5	1		992 1012 4
2-029	992-01050-011	WASHER 5	1		992 0035 6
2-030,1	722-01802-200	SPARK ARRESTER	1	-C117546	722 0180 6
2-030,2	732-01802-201	SPARK ARRESTER	1	C117547-	732 0070 9
2-033	116-32350-900	TENSION ADJUSTMENT BOLT ASS'Y	1		116 0070 5
2-034	462-32350-210	GUIDE PLATE B	1		462 0111 5
2-035	990-11040-061	SCREW 4X6	1		990 1025 4
2-036	906-32056-200	NAME PLATE ECS-370	1		906 1160 5
2-037	931-32377-201	EARMUFF CARE MARK	1		931 0030 6
2-038	718-01850-200	MUFFLER FLANGE	1	D170256-	718 0340 3
2-039	737-04050-200	MUFFLER GASKET	1	D170256-	737 0370 3
2-040	070-00601-201	CRANK SHAFT WASHER 12X18	1	-B172678	070 0000 1
2-041	990-21040-081	BOLT 4X8	1	-B172678	990 2195 5
2-042	991-01040-013	NUT 4	1	-B172678	991 0012 8
2-043	992-10050-012	S.WASHER 5	2	-B172678	992 1012 4
2-044	990-11050-101	SCREW 5X10	2	-B172678	990 1062 5

FIG.3 CARBURETOR & CLEANER

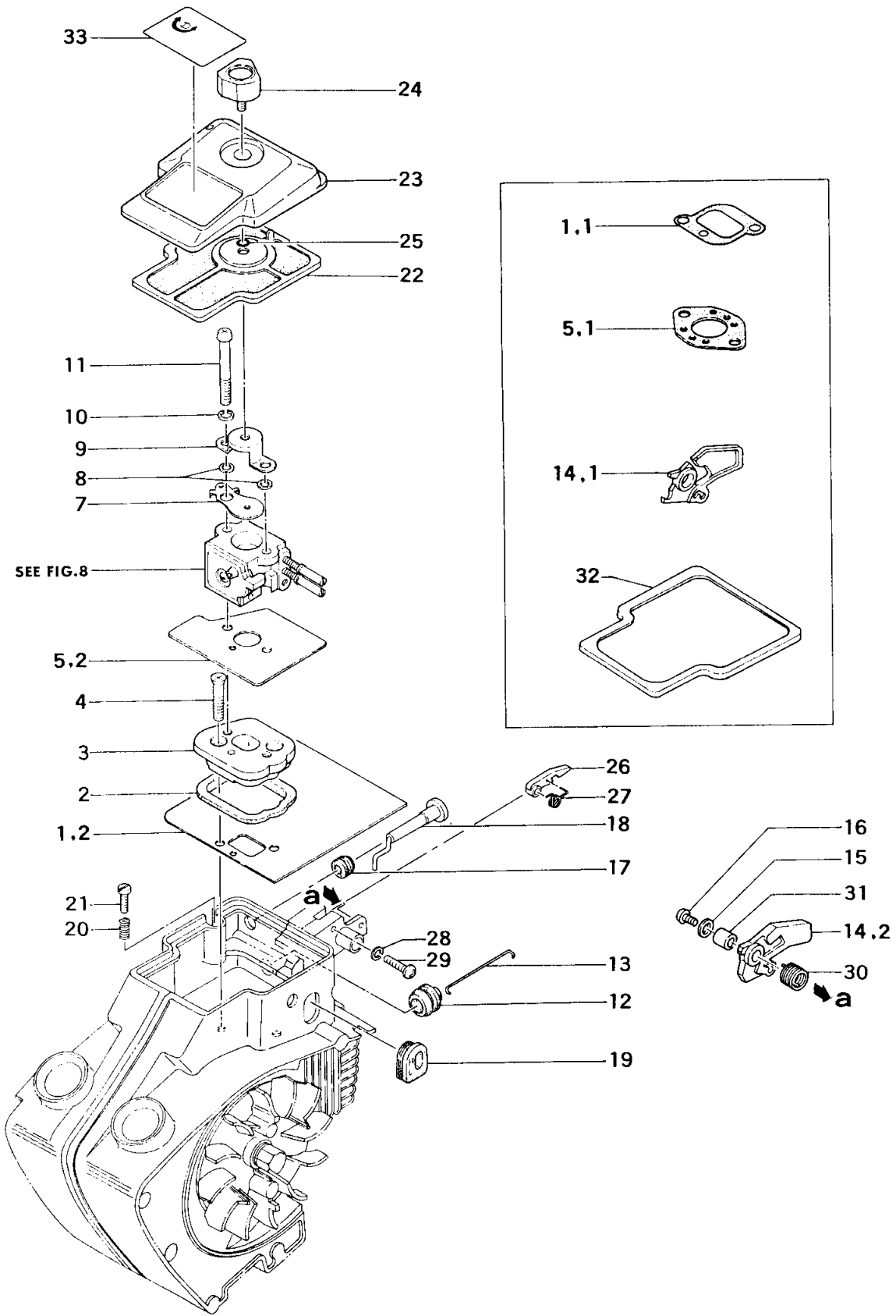

REFERENCE NUMBER	PRODUCTION PART NUMBER	PART NAME	QUANTITY	SERIAL NUMBER	SPARE PART NUMBER
FIG.3 CARBURETOR & CLEANER					
3-001,1	403-01800-201	INLET MANIFOLD GASKET	1	-B172678	403 0100 8
3-001,2	133-01850-201	HEAT SHIELD	1	B172679-	133 0290 0
3-002	409-01800-200	CARBURETOR INSULATOR RUBBER	1	-B172678	409 0000 7
3-002	409-01800-210	CARBURETOR INSULATOR RUBBER	1	B172679-	409 0001 6
3-003	404-01800-203	CARBURETOR INSULATOR	1		404 0120 9
3-004	990-12050-251	F.H.SCREW 5X25	2		990 1183 1
3-005,1	402-04019-211	CARBURETOR GASKET	1	-B172678	402 0051 2
3-005,2	402-01850-200	CARBURETOR GASKET	1	B172679-	402 0210 1
3-007	700-32350-211	CHOKE VALVE	1		700 2470 6
3-008	708-32350-200	CHOKE VALVE SHIM	2		708 0150 1
3-009	476-01802-200	BLOW OVER CHECK BOARD	1	-B172678	476 0920 1
3-009	476-01800-200	BLOW OVER CHECK BOARD	1	B172679-	476 0910 4
3-010	992-10050-012	S.WASHER 5	2		992 1012 4
3-011	990-11050-451	SCREW 5X45	2		990 1098 0
3-012	491-32350-201	THROTTLE GUIDE	1		491 0081 3
3-013	490-32050-201	THROTTLE ROD	1		490 0080 7
3-014,1	060-32050-212	THROTTLE LEVER	1	-B173657	060 0251 8
3-014,2	060-32050-214	THROTTLE LEVER	1	B173658-	060 0252 7
3-015	513-32057-200	WASHER	1	B173658-	513 0050 4
3-016	990-11030-121	SCREW 3X12	1	-B173657	990 1017 5
3-016	990-11030-141	SCREW 3X14	1	B173658-	990 1018 4
3-017	202-01003-201	SECONDARY CORD GROMMET	1		202 0011 2
3-018	704-32350-800	CHOKE BUTTON COMP.	1		704 0010 2
3-019	190-32314-200	ADJUSTER CAP	1		190 0100 1
3-020	845-11107-201	CONTROL LEVER SPRING/RK11	1		845 0010 2
3-021	990-06040-181	F.F.H. SCREW 4X18	1		990 0018 5
3-022	420-01800-801	CLEANER ELEMENT COMP.	1		420 0010 7
3-023	051-32050-200	CLEANER COVER	1	-A312060	051 0070 1
3-023	051-32050-210	CLEANER COVER	1	A312061-	051 0071 0
3-024	156-32050-800	CLEANER CAP COMP.	1	-A312061	156 0170 0
3-024	156-32050-810	CLEANER CAP KNOB COMP.	1	A312062-	156 0171 9
3-025	999-67003-000	O-RING P3	1		999 6701 3
3-026	259-32350-202	THROTTLE LOCK LEVER	1		259 0100 3
3-027	261-32350-201	THROTTLE LOCK SPRING	1		261 0101 9
3-028	992-10040-012	S.WASHER 4	1		992 1007 2
3-029	990-11040-201	SCREW 4X20	1		990 1044 9
3-030	061-32057-200	THROTTLE LEVER SPRING	1	B173658-	061 0440 5
3-031	511-32050-200	COLLAR	1	B173658-	511 0960 7
3-032	431-01800-200	CLEANER GASKET	1	-A275615	431 0040 8
4-033	912-32056-200	CLEANER COVER MARK ECS-370	1		912 0070 5

FIG.4 RECOIL STARTER

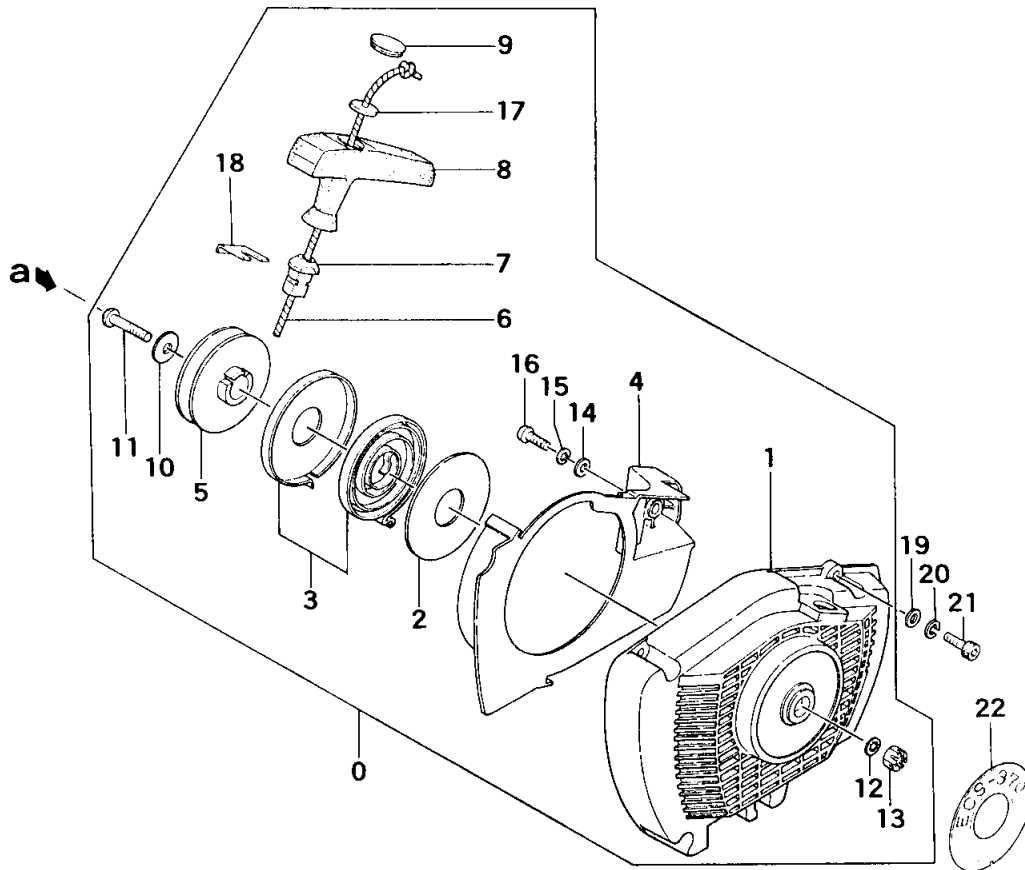
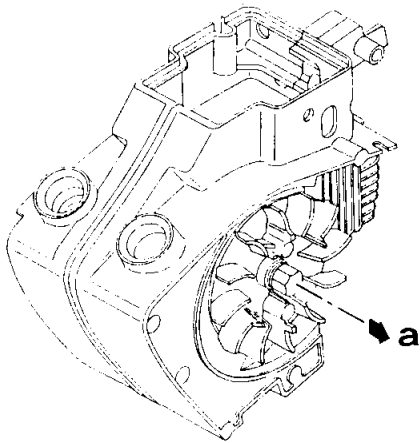

REFERENCE NUMBER	PRODUCTION PART NUMBER	PART NAME	QUANTITY	SERIAL NUMBER	SPARE PART NUMBER
FIG.4 RECOIL STARTER					
4-000	756-01856-902	RECOIL STARTER ASS'Y	1		756 0930 2
4-001	112-01850-801	FAN CASE COMP.	1	-C117540	112 0700 9
4-001	112-01850-801	FAN CASE COMP.	1	C117541-	112 1520 6
4-002	778-00601-201	RECOIL SPRING CASE COVER	1	-D170255	778 0010 1
4-002	827-04060-210	RECOIL SPRING CASE COVER	1	D170256-	827 0071 1
4-003	778-01800-900	RECOIL SPRING CASE ASS'Y	1	-D170255	778 0040 2
4-003	778-00601-900	RECOIL SPRING CASE ASS'Y	1	D170256-	778 0120 1
4-004	145-01850-202	COVER	1		145 0000 8
4-005	774-00601-806	STARTER ROPE REEL COMP.	1		774 0031 6
4-006	793-01800-209	STARTER ROPE 3.5X960	1		793 0070 1
4-007	780-11600-200	ROPE GUIDE	1		780 0120 8
4-008	785-11600-202	STARTER HANDLE	1		785 0140 7
4-009	833-10207-200	STARTER HANDLE CAP	1		833 0000 8
4-010	992-08050-006	SPECIAL WASHER 5	1		992 0068 4
4-011	990-11050-251	SCREW 5X25	1		990 1082 9
4-012	992-20050-000	INNER TOOTHED WASHER 5	1		992 2003 5
4-013	991-20050-011	HEX. SLOTTED NUT	1		991 2001 0
4-014	992-00050-011	SMALL WASHER 5	1		992 0009 1
4-015	992-10050-012	S. WASHER 5	1		992 1012 4
4-016	993-11052-013	TAPPING SCREW 5X20	1	-D130490	993 1006 0
4-016	990-11050-201	SCREW 5X20	1	D130491-	990 1077 7
4-017	795-11600-200	ROPE STOPPER	1	C207934-	795 0050 4
4-018	781-11600-200	HANDLE GUIDE HOLDER METAL	1		781 0000 8
4-019	992-00050-011	SMALL WASHER 5	4		992 0009 1
4-020	992-10050-012	S. WASHER 5	4		992 1012 4
4-021	990-51050-153	HEX. HOLE BOLT 5X15	4		990 5006 5
4-022	915-32056-200	STARTER MARK USA	1		915 0070 6

FIG.5 REAR HANDLE

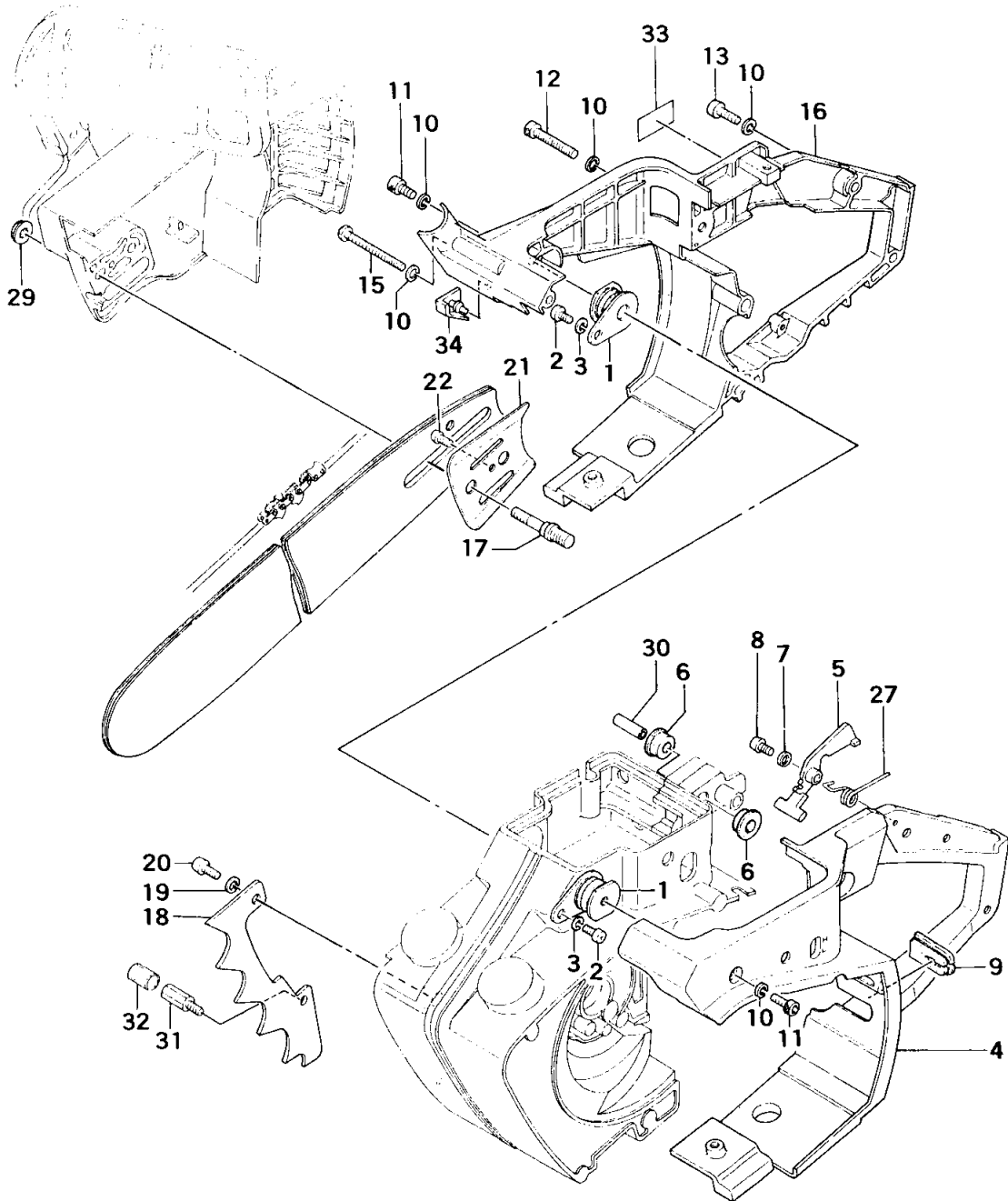

REFERENCE NUMBER	PRODUCTION PART NUMBER	PART NAME	QUANTITY	SERIAL NUMBER	SPARE PART NUMBER
FIG.5 REAR HANDLE					
5-001	222-32350-801	SIDE DAMPER COMP.	2		222 0050 7
5-002	990-11050-121	SCREW 5X12	2		990 1065 2
5-003	992-10050-012	S.WASHER 5	2		992 1012 4
5-004	010-32050-201	HANDLE/REAR A	1	-C207933	010 0230 0
5-004	010-32050-212	HANDLE/REAR A	1	C207934-	010 0231 9
5-005	257-32050-202	SAFETY LLVER	1		257 0020 0
5-006	250-32350-201	SAFETY DAMPER	2		250 0051 1
5-007	992-01030-011	WASHER 3	1		992 0028 6
5-008	990-11030-081	SCREW 3X8	1		990 1014 8
5-009	202-01800-202	SECONDARY CORD GROMMET	1		202 0051 0
5-010	992-10050-012	S.WASHER 5	5		992 1012 4
5-011	990-51050-153	HEX. HOLE BOLT 5X15	2		990 5006 5
5-012	990-51050-353	HEX. HOLE BOLT 5X35	1		990 5017 1
5-013	990-11050-151	SCREW 5X15	1		990 1069 8
5-015	990-11050-451	SCREW 5X45	1		990 1098 0
5-016	011-32050-201	HANDLE/REAR B	1	-C207933	011 0080 6
5-016	011-32050-213	HANDLE/REAR B	1	C207934-	011 0081 5
5-017	101-32350-200	CHAIN BAR CLAMPING BOLT	2		101 0050 3
5-018	460-32350-210	SPIKE	1		460 0132 4
5-019	992-10050-012	S.WASHER 5	2		992 1012 4
5-020	990-11050-121	SCREW 5X12	2		990 1065 2
5-021	461-32350-210	GUIDE PLATE A	1		461 0141 9
5-022	990-11040-061	SCREW 4X6	2		990 1025 4
5-027	258-32050-200	SAFETY SPRING	1		258 0090 6
5-029	121-32350-200	CHAIN BAR CLAMP NUT	2		121 0050 9
5-030	251-32350-200	SAFETY DAMPER COLLER	1		251 0210 7
5-031	125-32060-210	CHAIN CATCHER	1	B107332-	125 0022 4
5-032	700-01012-018	VINYL PIPE	1	B107332-	700 0270 2
5-033	913-32377-200	CHOKE MARK	1		913 0130 7
5-034	240-32550-200	SHEET DUMPER	1		240 0070 3

FIG.6 HANDLE & STOP SWITCH

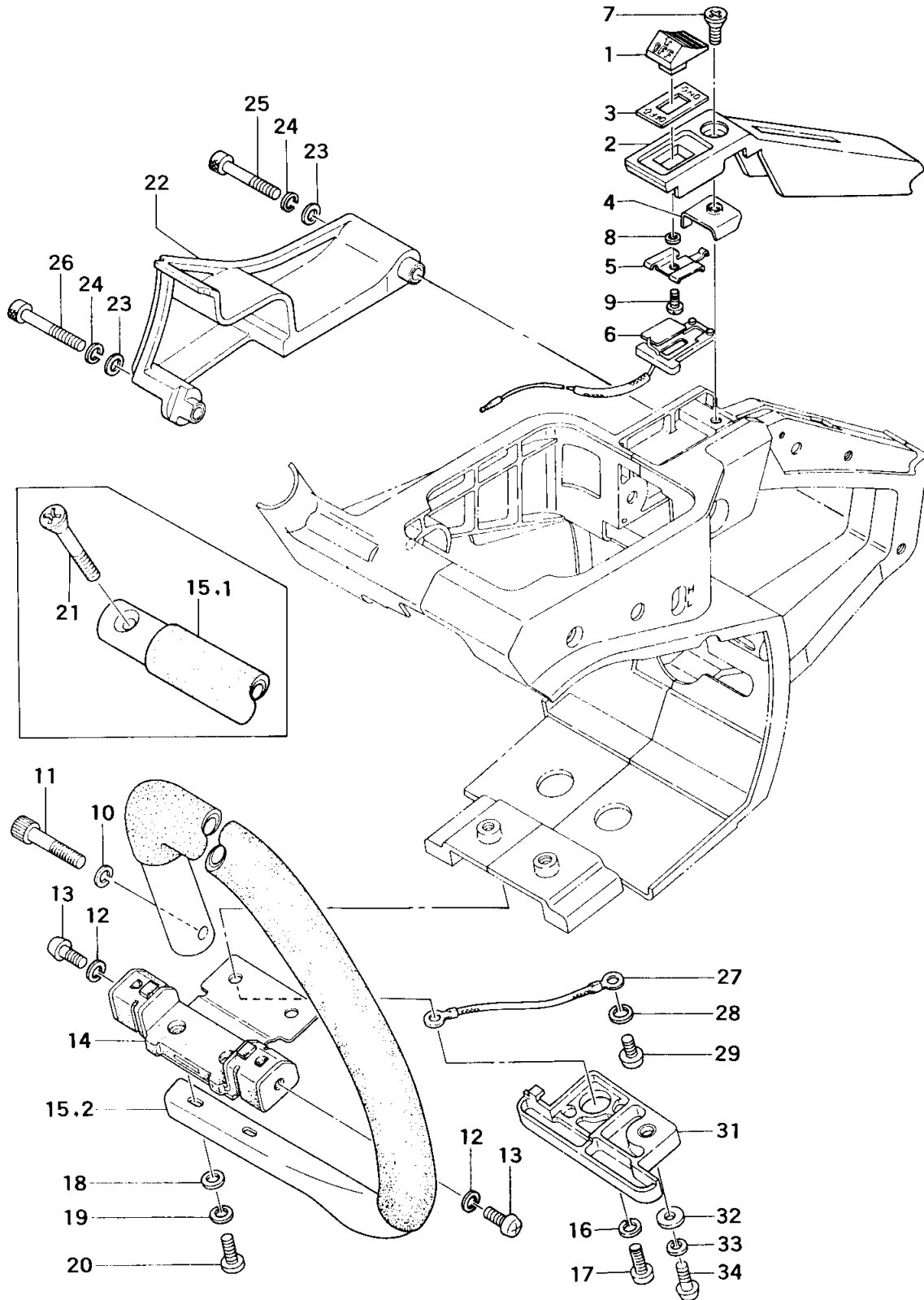

REFERENCE NUMBER	PRODUCTION PART NUMBER	PART NAME	QUANTITY	SERIAL NUMBER	SPARE PART NUMBER
FIG.6 HANDLE & STOP SWITCH					
6-001	258-04015-202	STOP BUTTON	1		258 0001 2
6-002	226-32050-200	HANDLE GRIP B	1		226 0060 2
6-003	925-32350-200	ON-OFF MARK	1		925 0040 8
6-004	272-04015-204	GROUND TERMINAL	1		272 0001 6
6-005	261-01800-201	STOP BUTTON TERMINAL	1		261 0010 4
6-006	178-01800-804	STOP CORD COMP.	1		178 0311 3
6-007	990-12050-151	F.H. SCREW 5X15	1	-D170255	990 1181 3
6-007	990-12050-121	F.H. SCREW 5X12	1	0170256-	990 1217 1
6-008	992-00040-011	SMALL WASHER 4	1		992 0008 2
6-009	990-11040-061	SCREW 4X6	1		990 1025 4
6-010	992-10060-012	S.WASHER 6	1	C207934-	992 1019 7
6-011	990-51060-303	HEX. HOLE BOLT 6X30	1	C207934-	990 5023 2
6-012	992-10050-012	S.WASHER 5	2		992 1012 4
6-013	990-11050-121	SCREW 5X12	2		990 1065 2
6-014	219-32350-804	DAMPER FRONT COMP.	1		219 0041 5
6-015.1	209-32055-800	FRONT HANDLE COMP.	1	-C207933	209 0020 9
6-015.2	209-32550-801	FRONT HANDLE COMP.	1	C207934-	209 0120 2
6-016	992-10050-012	S.WASHER 5	2		992 1012 4
6-017	990-11050-121	SCREW 5X12	2		990 1065 2
6-018	992-01050-011	WASHER 5	2		992 0035 6
6-019	992-10050-012	S.WASHER 5	2		992 1012 4
6-020	990-11050-151	SCREW 5X15	2		990 1069 8
6-021	990-13060-301	OVAL COUNTERSUNK SCREW 6X30	1	-C207933	990 1196 5
6-022	800-32350-802	REAR HAND GUARD	1		800 0081 3
6-023	992-00050-011	SMALL WASHER 5	2		992 0009 1
6-024	992-10050-012	S.WASHER 5	2		992 1012 4
6-025	990-51050-303	HEX. HOLE BOLT 5X30	1		990 5016 2
6-026	990-51050-353	HEX. HOLE BOLT 5X35	1	-C117546	990 5017 1
6-026	990-51050-403	HEX. HOLE BOLT 5X40	1	C117547-	990 5018 0
6-027	274-01800-800	GROUND CORD COMP.	1		274 0000 1
6-028	992-10050-012	S.WASHER 5	1		992 1012 4
6-029	990-11050-101	SCREW 5X10	1		990 1062 5
6-031	797-32050-800	EARTH CORD COVER	1	C117547-	797 0020 7
6-032	992-00050-011	SMALL WASHER 5	1		992 0009 1
6-033	992-10050-012	S.WASHER 5	1		992 1012 4
6-034	990-11050-161	SCREW 5X16	1		990 1070 4

FIG.7 OIL PUMP

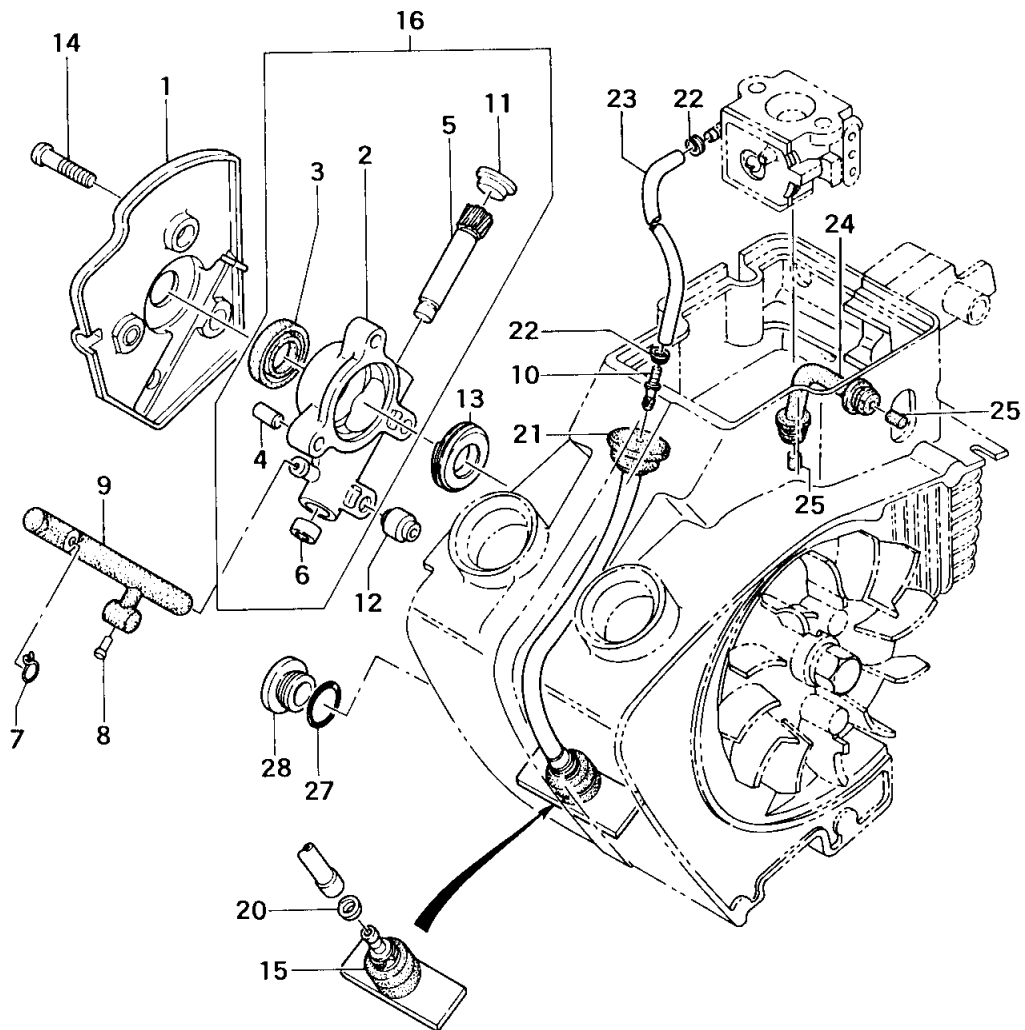
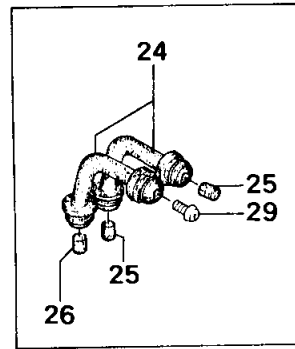

REFERENCE NUMBER	PRODUCTION PART NUMBER	PART NAME	QUANTITY	SERIAL NUMBER	SPARE PART NUMBER
FIG.7 OIL PUMP					
7-001	097-32350-801	OIL PUMP SHROUD COMP.	1		097 0001 5
7-002	088-32350-800	OIL PUMP CASE COMP.	1		088 0040 8
7-003	999-66132-420	OIL SEAL AC13246	1		999 6618 0
7-004	999-05040-800	KNOCK PIN 4X8	1		999 0501 3
7-005	085-32350-201	PUMP GEAR	1		085 0020 3
7-006	086-32350-211	GROMMET A	1		086 0001 5
7-007	680-03113-200	CLIP 7.5	1		680 0140 1
7-008	516-32350-201	OIL JET	1	A312061-	516 0030 1
7-009	515-32350-201	OIL PIPE A	1		515 0030 4
7-010	497-32350-200	PIPE JOINT	1		497 0030 1
7-011	053-32500-201	GROMMET B	1		053 0080 2
7-012	622-00604-201	AIR PIPE	1		622 0020 0
7-013	084-32350-200	SCREW GEAR	1		084 0020 6
7-014	990-11050-221	SCREW 5X22	3		990 1080 1
7-015	675-01801-901	PUMP FILTER BODY ASS'Y	1		675 0240 6
7-016	088-32350-901	OIL PUMP CASE ASS'Y	1		088 0050 5
7-020	680-04019-210	CLIP 7	1		680 0162 3
7-021	678-32350-200	RUBBER PIPE/SUCTION	1		678 0210 6
7-022	680-00206-200	CLIP 5.5	2		680 0010 7
7-023	700-13005-060	FUEL PIPE	1	-D020480	700 1730 8
7-023	700-13005-055	FUEL PIPE	1	D020481-	700 2810 6
7-024	565-01800-202	AIR VENT PIPE	2		565 0042 4
7-025	567-01800-200	AIR VENT SPONGE	2		567 0000 2
7-026	566-01800-200	AIR VENT FELT	1	-B045746	566 0000 5
7-027	999-67012-500	O-RING P12.5	1		999 6715 6
7-028	525-32350-201	OIL LEVEL CAP	1		525 0070 5
7-029	990-11040-101	SCREW 4X10	1	-D045746	990 1029 0

FIG.8 CARBURETOR

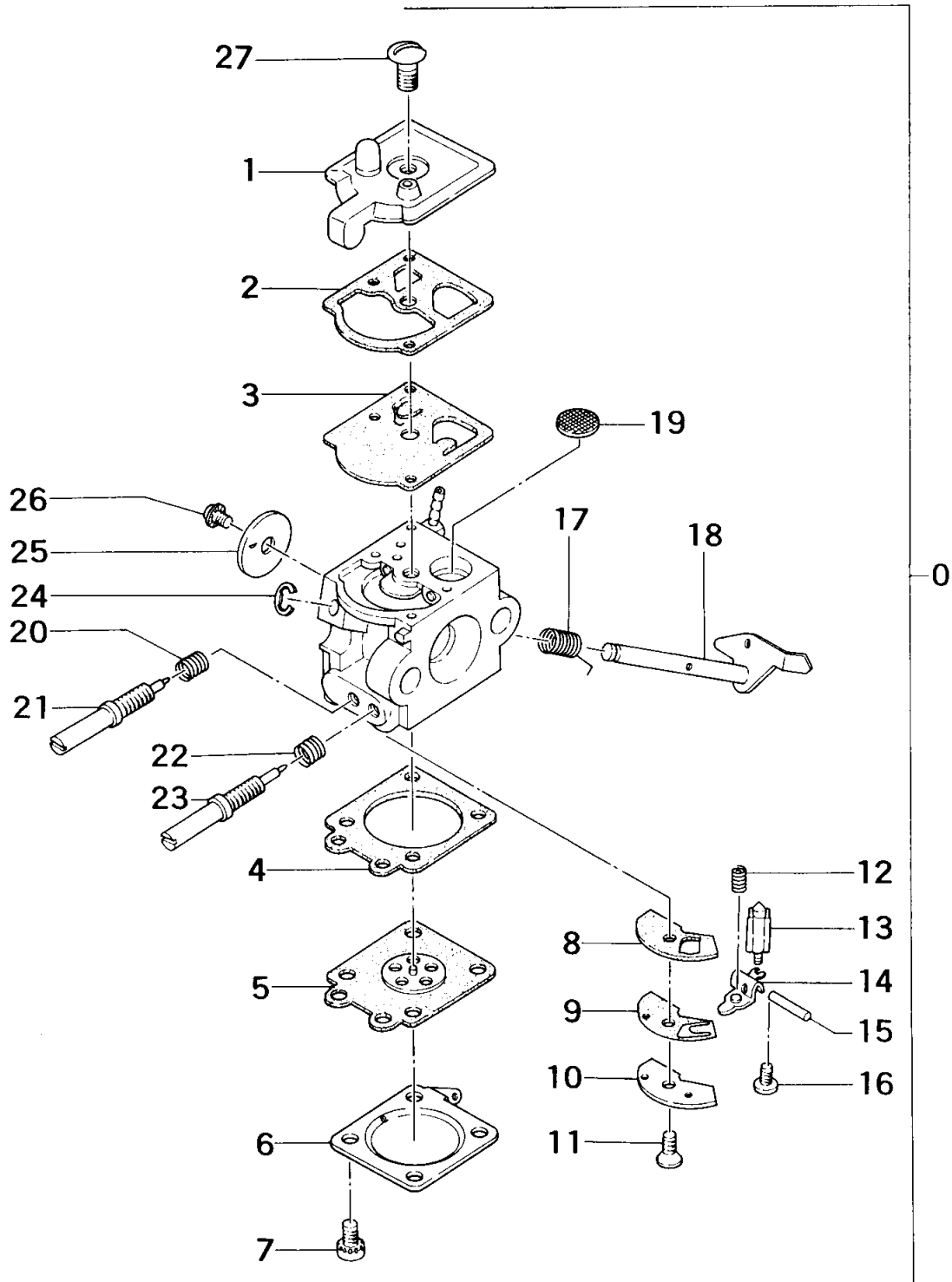

REFERENCE NUMBER	PRODUCTION PART NUMBER	PART NAME	QUANTITY	SERIAL NUMBER	SPARE PART NUMBER
FIG.8 CARBURETOR					
8-000	455-25011-900	CARBURETOR ASS'Y	1	455 1860 9	
8-001	575-25005-200	PUMP BODY	1	575 0110 1	
8-002	577-25001-200	PUMP GASKET	1	577 0070 4	
8-003	576-25001-200	PUMP DIAPHRAGM	1	576 0060 0	
8-004	475-25001-200	DIAPHRAGM GASKET	1	475 0080 6	
8-005	474-25001-800	METERING DIAPHRAGM COMP.	1	474 0070 2	
8-006	476-25003-200	DIAPHRAGM CASE	1	476 0120 4	
8-007	548-25014-200	SET SCREW	4	548 0040 1	
8-008	522-25001-200	CIRCUIT PLATE GASKET	1	522 0030 6	
8-009	521-25001-200	CIRCUIT CHECK VALVE DIAPHRAGM	1	521 0010 5	
8-010	523-25001-200	CIRCUIT PLATE	1	523 0040 0	
8-011	524-25001-200	CIRCUIT PLATE SCREW	1	524 0040 7	
8-012	477-25007-200	VALVE SPRING	1	477 0080 0	
8-013	603-25001-200	NEEDLE VALVE	1	603 0290 6	
8-014	473-25001-200	VALVE HINGE	1	473 0060 8	
8-015	605-25001-200	HINGE PIN	1	605 0230 8	
8-016	546-25001-200	HINGE PIN SET SCREW	1	546 0030 0	
8-017	486-25005-200	THROTTLE SPRING	1	486 0040 8	
8-018	464-25003-801	THROTTLE SHAFT COMP.	1	464 0031 0	
8-019	578-25001-200	INLET SCREEN	1	578 0020 6	
8-020	623-25001-200	HIGH/LOW ADJUST SPRING	1	623 0170 5	
8-021	461-25005-200	LOW ADJUST SCREW	1	461 0060 1	
8-022	485-25005-200	ADJUST SPRING/HIGH	1	485 0080 9	
8-023	460-25003-200	MAIN ADJUST SCREW	1	460 0050 7	
8-024	489-25001-200	STOP RING	1	489 0020 5	
8-025	488-25001-200	THROTTLE VALVE	1	488 0020 8	
8-026	467-25003-200	SHUTTER SCREW	1	467 0010 8	
8-027	514-25001-200	SET SCREW	1	514 0010 3	

FIG.9 TOOLS

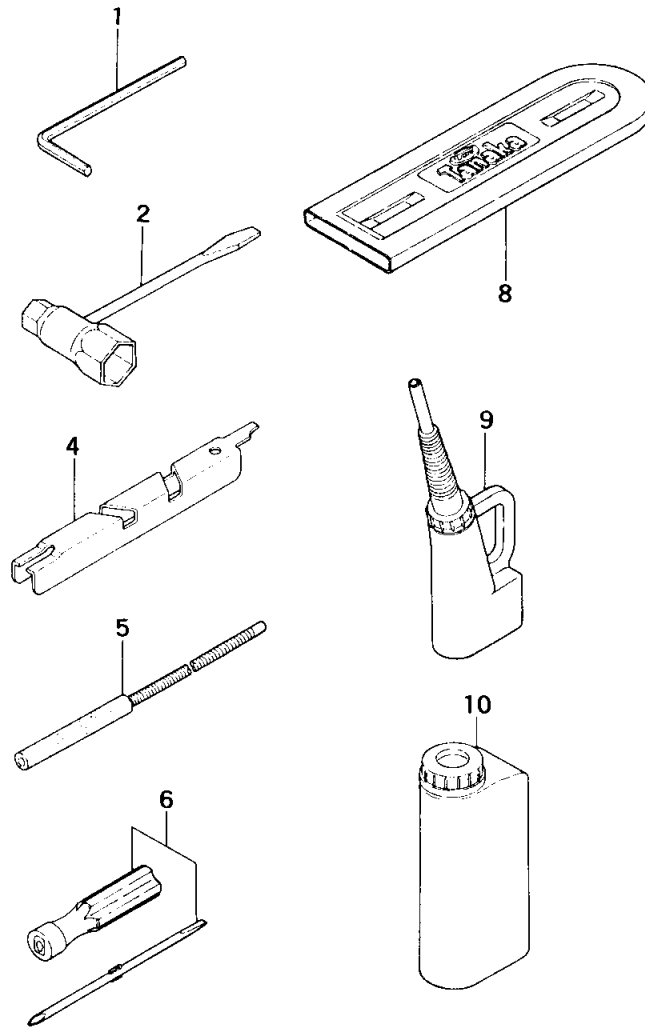

REFERENCE NUMBER	PRODUCTION PART NUMBER	PART NAME	QUANTITY	SERIAL NUMBER	SPARE PART NUMBER
FIG.9 TOOLS					
9-001	813-20000-200	HEX. WRENCH 4	1		813 0000 2
9-002	013-29323-501	COMBI BOX SPANNER 10X19	1		013 0280 6
9-004	930-32057-200	DEPTH GAUGE	1		930 0150 6
9-005	936-20000-900	FILE ASS*Y 5/32	1		936 0020 4
9-006	901-32600-900	DRIVER ASS*Y	1		901 0020 0
9-008	946-37052-201	CHAIN COVER 14	1		946 0100 6
9-008	947-32055-201	CHAIN COVER 16	1		947 0110 0
9-009	840-32600-900	FUEL MIXING OILER ASS*Y	1		840 0060 2
9-010	872-20000-201	FULL PREMIX CANISTER	1		872 0001 2

Free Manuals Download Website

<http://myh66.com>

<http://usermanuals.us>

<http://www.somanuals.com>

<http://www.4manuals.cc>

<http://www.manual-lib.com>

<http://www.404manual.com>

<http://www.luxmanual.com>

<http://aubethermostatmanual.com>

Golf course search by state

<http://golfingnear.com>

Email search by domain

<http://emailbydomain.com>

Auto manuals search

<http://auto.somanuals.com>

TV manuals search

<http://tv.somanuals.com>