

# ***Tanaka***

## **Parts Catalog**

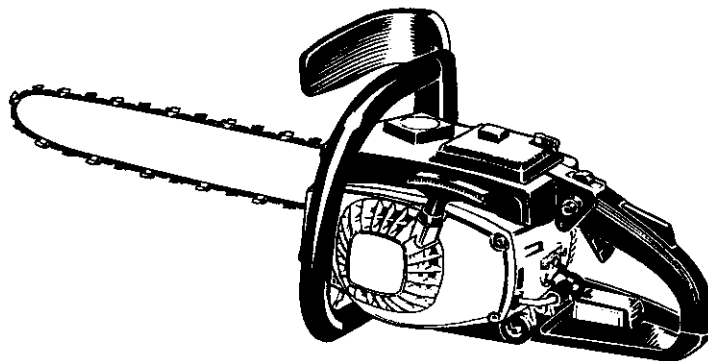

## **Chain Saw**

### **Model: ECS-4000/B**

Part # 11840 9-26-97

# ECS-4000/B

## OPTIONS AND ACCESSORIES

### BARS & CHAINS

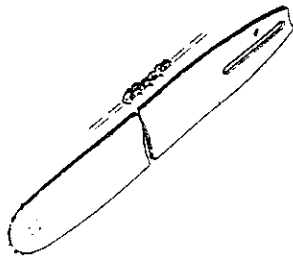

16 In. Chain 33SL066X  
18 in. Chain 33SL072X

16 In. Bar 160PXBK041  
18 In. Bar 180PXBK041

16in. Bar/Chain Kit 844003  
18in. Bar/Chain Kit 844008

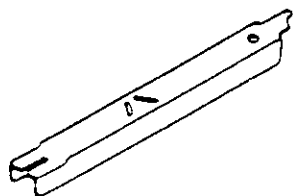

**DEPTH GAUGE CDG-600**

### MANUALS & CATALOGS

24785 Owner's Manual  
11840 Parts Catalog

### PERFECT MIX® 2-Cycle Engine Oil

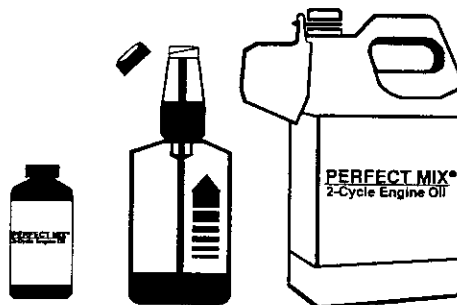

700109 2.8 oz. Bottle, 1 Gallon Size (24\*)  
700108 16 oz. Self-measuring Bottle (24\*)  
700110 1 Gallon Jug Commercial Size (6\*)  
\* Case Quantity

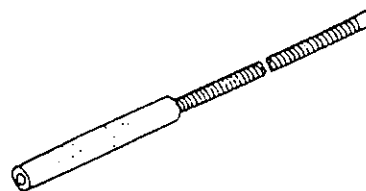

**FILE ASS'Y 5/32 CSF-532**

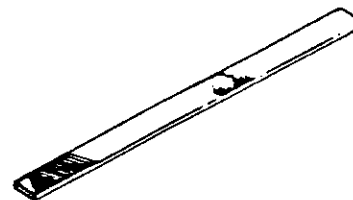

**FLAT FILE 8" CSF-800**

### SPECIAL TOOLS

006-29326-000	Flywheel Remover	890-32600-200	Clutch Remover
009-29323-500	Piston Pin Remover	001-29000-000	Tachometer
898-20000-900	Screw Gear Remover	070-2000W-500	Pressure Tester
002-29323-501	Screw Gear Inserter	070-2000W-501	Carb. Tool Kit

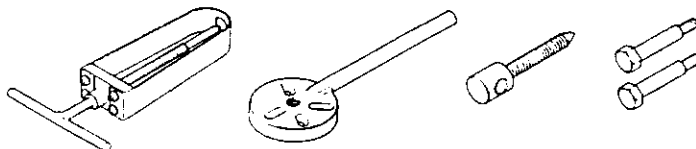

FIG.1 ENGINE

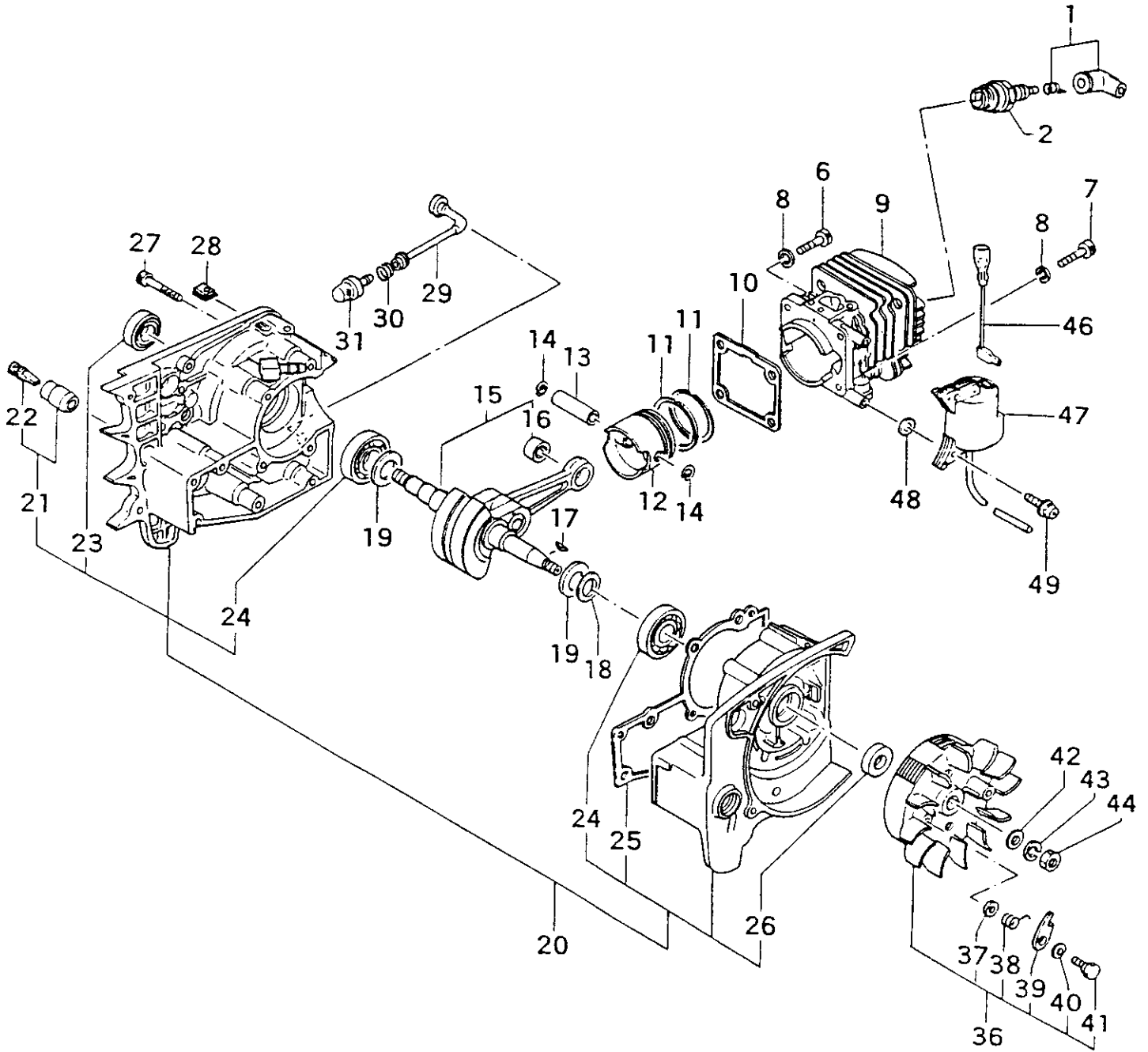

FIGURE 1

## ECS-4000/B PARTS LISTING

REF.	PART NO.	PART DESCRIPTION	Q	C	S	SERIAL NO.	REMARKS
1	157-11666-900	CAP,SPARK PLUG ASS'Y	1		C		
2	018-11660-21	PLUG,SPARK	1		B		
6	990-51050-183	BOLT,HEX,5X18	2		D		
7	990-51050-223	BOLT,HEX,5X22	2		C		
8	992-10050-012	WASHER,S,5	4		A		
9	002-04040-202	CYLINDER	1		D		
10	017-04090-210	GASKET,CYLINDER	1		D		
11	041-04050-200	RING,PISTON	2		A		
12	031-04050-200	PISTON	1		D		
13	037-01400-200	PIN,PISTON	1		C		
14	039-00000-201	CIRCLIP,PISTON PIN	2		A		
15	046-04069-800	CRANKSHAFT	1		D		
16	999-62091-325	BEARING,NEEDLE,F-910	1		D		
17	068-10100-200	KEY,WOODRUFF,3X13X4.5	1		C		
18	071-02007-200	SHIM,15.2X20X.05	V		D		
18	071-02007-210	SHIM,15.2X20X.10	V		D		Shims are "as needed" to obtain correct c/s side clearance.
18	071-02007-220	SHIM,15.2X20X.15	V		D		
18	071-11600-230	SHIM,16X21X.20	V		D		
18	071-11600-240	SHIM,16X21X.30	V		D		
19	070-02401-201	WASHER,CRANKSHAFT 15X22	2		D		
20	072-04080-920	CRANKCASE,ASS'Y	1		D		Includes bearings, seals and gasket
21	645-32530-900	HOLDER,VALVE,ASS'Y	1		D		
22	562-04060-200	VALVE,AIR VENT,B	1		C		
23	999-66152-511	SEAL,OIL,#VE15X25X7	1		A		
24	999-61620-200	BEARING,BALL,#6202	2		B		
25	090-04060-202	GASKET,CASE,CRANK	1		D		
26	999-66122-240	SEAL,OIL,#12227	1		A		
27	990-51050-303	BOLT,HEX,5X30	8		D		
28	488-32530-202	GROMMET,OIL ADJUST	1		D		
29	505-32530-220	PIPE,OIL,B	1		D		
30	680-04019-210	CLIP,7	1		B		
31	486-32710-900	BODY,OIL FILTER ASS'Y	1		D		
36	155-21719-900	ROTOR,MAGNETO	1		D		
37	786-00601-200	WASHER,RECOIL STARTER	2		D		
38	790-01800-200	SPRING,STARTER PAWL	2		D		
39	788-00601-203	PAWL,STARTER	2		A		
40	822-00601-200	SHIM,7X11.8X.60	2		C		
41	793-10200-202	BOLT,STEP	2		C		
42	992-01070-011	WASHER,7	1		D		

\* Indicates the part is included in a kit or assembly and is not available individually. Q=Quan. used  
C=Interchangeability S=Stocking code: A=Fast moving B=Med. fast C=Med. move D=Slow move  
E=N.L.A. F=Superceded or replaced by a new part

FIGURE 1 cont.

ECS-4000 PARTS LISTING

REF.	PART NO.	PART DESCRIPTION	Q	C	S	SERIAL NO.	REMARKS
43	992-10070-012	WASHER,S,7	1		D		
44	066-01800-200	NUT,FLYWHEEL	1		D		
46	178-04080-800	CORD,STOP	1		D		
47	167-21952-800	COIL,IGNITION	1		C		
48	182-0186A-201	WASHER,SPECIAL	2		D		
49	994-16040-226	SCREW,WS,4X22	2		D		

\* Indicates the part is included in a kit or assembly and is not available individually. Q=Quan. used  
 C=Interchangeability S=Stocking code: A-Fast moving B=Med. fast C=Med. move D=Slow move  
 E=N.L.A. F=Superceded or replaced by a new part  
 Downloaded from [www.manuals.com](http://www.manuals.com). All Manuals Search And Download.

# FIG.2 ENGINE COMPONENTS

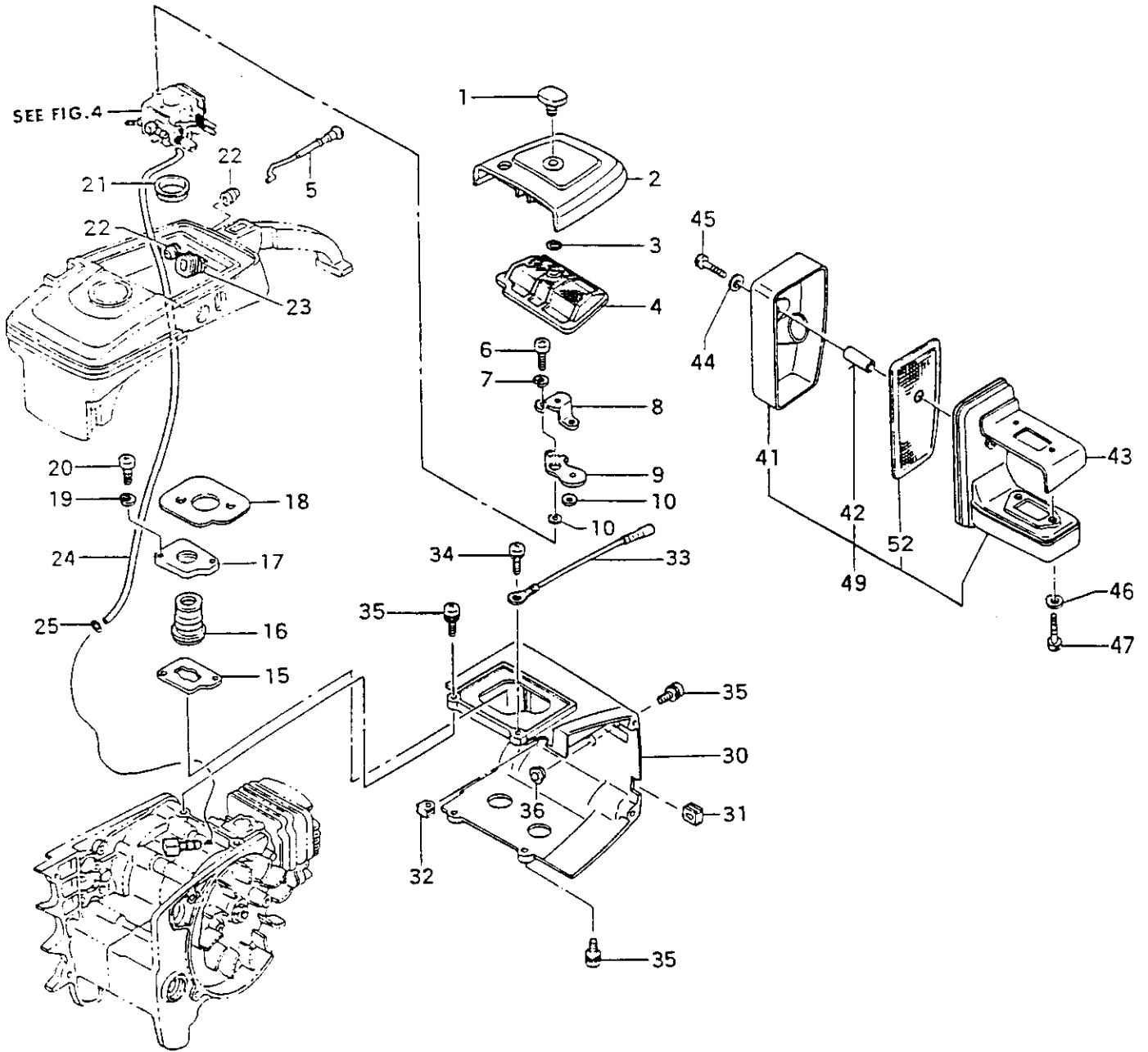

FIGURE 2

## ECS-4000/B PARTS LISTING

REF.	PART NO.	PART DESCRIPTION	Q	C	S	SERIAL NO.	REMARKS
1	175-32530-800	KNOB,CLEANER	1		C		
2	051-32810-200	COVER,CLEANER	1		D		
3	999-67003-000	O-RING,P3	1		C		
4	420-04080-800	ELEMENT,CLEANER	1		C		
5	704-32540-800	BUTTON,CHOKE	1		D		
6	990-11050-401	SCREW,5X40	2		C		
7	992-10050-012	WASHER,S,5	2		A		
8	476-04060-200	BOARD,BLOW OVER CHECK	1		D		
9	700-32540-200	VALVE,CHOKE	1		C		
10	708-32350-200	SHIM,5.2X8X.80	2		C		
15	403-04080-200	GASKET,INTAKE MANIFOLD	1		D		
16	393-04090-200	MANIFOLD,INTAKE	1		C		
17	392-04090-200	FLANGE,MANIFOLD	1		D		
18	138-04080-200	DEFLECTOR,AIR A	1		D		
19	992-10040-012	WASHER,S,4	2		D		
20	990-11040-141	SCREW,4X14	2		B		
21	400-32540-200	SPACER,INLET MANIFOLD	1		D		
22	202-01003-201	GROMMET,SECONDARY CORD	2		C		
23	491-32540-200	ROD,THROTTLE	1		D		
24	700-12665-110	PIPE,FUEL	1		D		
25	680-00731-201	CLIP 6.3	1		B		
30	016-04080-801	COVER,CYLINDER	1		D		
31	203-0604A-202	GROMMET	1		C		
32	203-06000-200	GROMMET,PRIMARY CORD	1		C		
33	274-04080-800	CORD,EARTH	1		D		
34	994-14050-162	SCREW,S,5X16	1		C		
35	994-15050-162	SCREW,5X16/PS	5		C		
36	027-0630A-201	COLLAR	2		C		
41	717-04075-800	BODY,MUFFLER,B	1		D		
42	740-01802-200	COLLAR,MUFFLER	1		D		
43	737-04090-200	GASKET,MUFFLER	1		D		
44	992-01050-011	WASHER,5	1		A		
45	990-51050-353	BOLT,HEX.HOLE,5X35	1		C		
46	992-00050-011	WASHER,SMALL,5	2		C		
47	990-51050-353	BOLT,HEX.HOLE,5X35	2		C		
49	705-04079-900	MUFFLER,ASS'Y	1		D		
52	732-04079-200	ARRESTER,SPARK	1		D		

\* Indicates the part is included in a kit or assembly and is not available individually. Q=Quan. used  
C=Interchangeability S=Stocking code: A=Fast moving B=Med. fast C=Med. move D=Slow move  
E=N.L.A. F=Superseded or replaced by a new part

# FIG.3 RECOIL STARTER

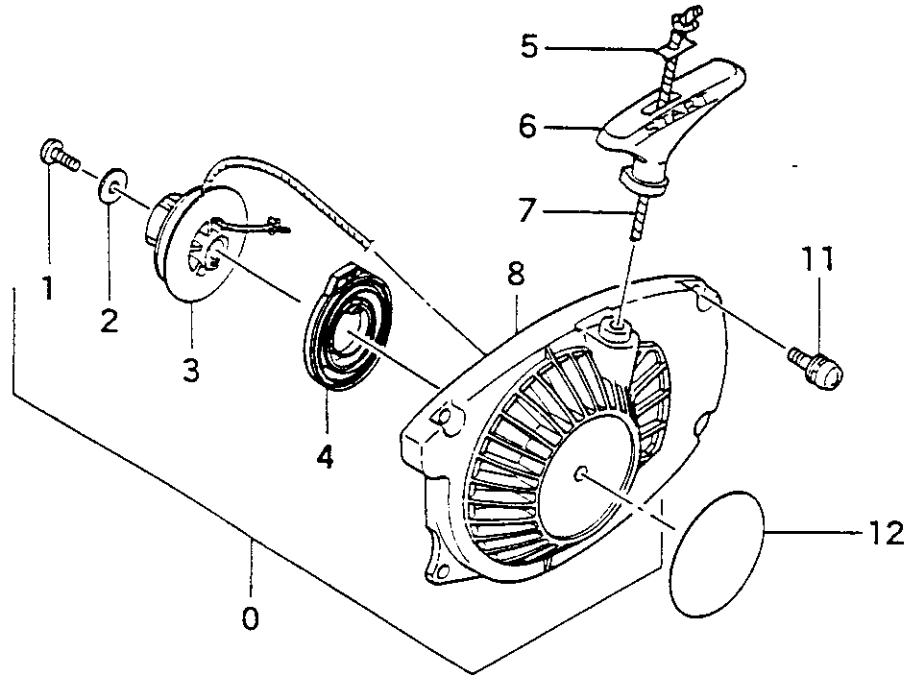

FIGURE 3

## ECS-4000/B PARTS LISTING

REF.	PART NO.	PART DESCRIPTION	Q	C	S	SERIAL NO.	REMARKS
0	756-04080-900	STARTER,RECOIL ASS'Y	1		D		
1	990-15050-121	SCREW,5X12	1		D		
2	992-08050-006	WASHER,5	1		C		
3	774-04063-800	REEL,STARTER ROPE	1		D		
4	778-00601-900	SPRING,RECOIL,ASS'Y	1		B		
5	795-04063-200	STOPPER,ROPE	1		D		
6	785-04063-200	HANDLE,STARTER	1		D		
7	783-04075-200	ROPE,STARTER	1		C		
8	112-04080-800	CASE,FAN	1		D		
11	994-16050-162	SCREW,5X16/WS	4		D		
12	950-37900-200	DECAL,PRO-FORCE A	1		C		



# FIG.4 CARBURETOR

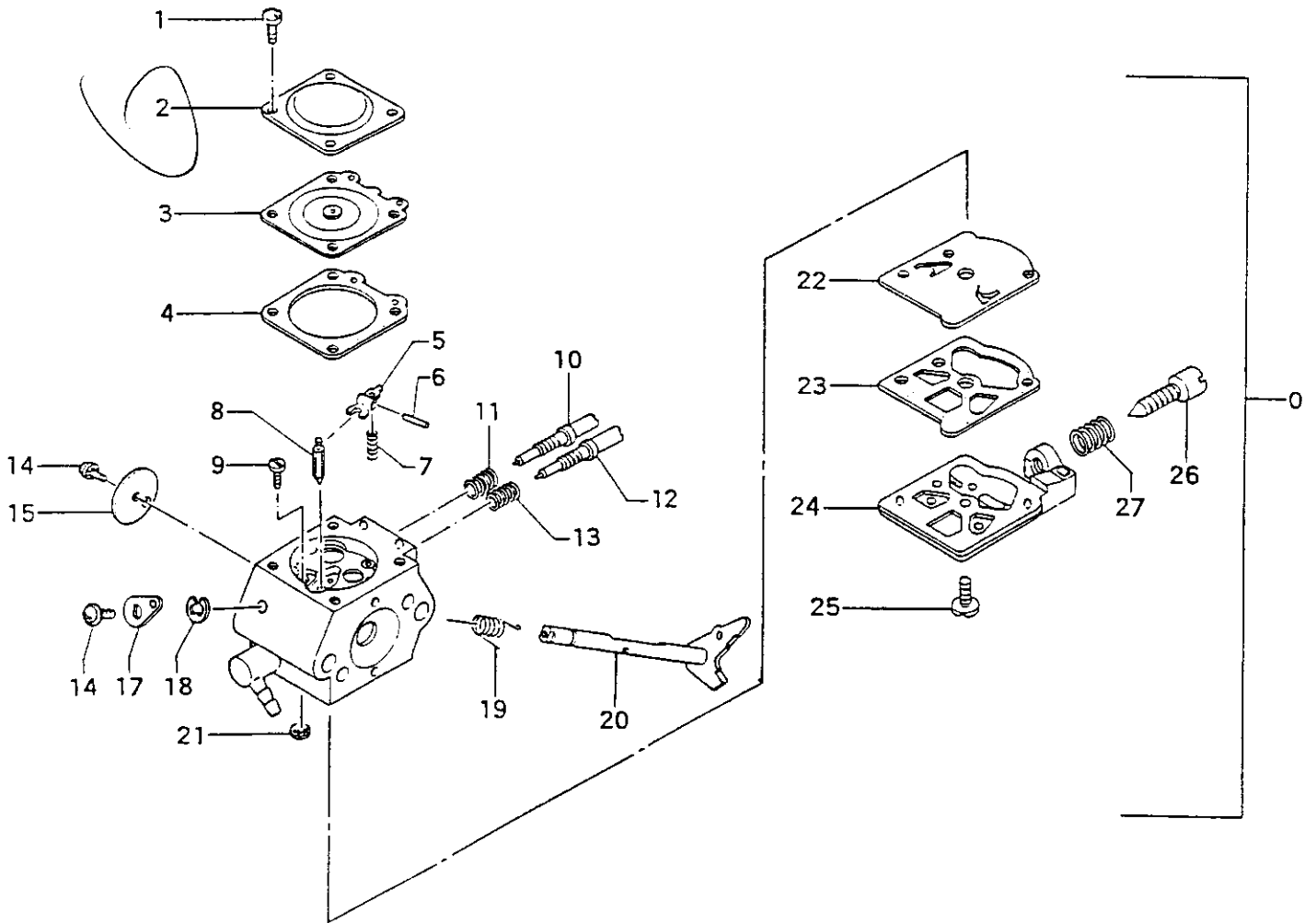

FIGURE 4

## ECS-4000/B PARTS LISTING

REF.	PART NO.	PART DESCRIPTION	Q	C	S	SERIAL NO.	REMARKS
0	455-25052-900	CARBURETOR,ASS'Y	1		D		
1	548-25012-200	SCREW,SET	4		D		
2	476-25004-200	COVER,DIAPHRAGM	1		D		
3	---	*DIAPHRAGM,METERING	1		A		
4	---	*GASKET,DIAPHRAGM	1		A		
5	---	*HINGE,VALVE	1		C		
6	---	*PIN,FLOAT	1		D		
7	477-25013-200	SPRING,VALVE	1		D		
8	---	*VALVE,NEEDLE	1		C		
9	546-25001-200	SCREW,SET,HINGE PIN	1		D		
10	461-25043-200	SCREW,LOW ADJUST	1		D		
11	623-25032-200	SPRING,ADJUST,HI/LOW	1		D		
12	460-25027-200	SCREW,HIGH ADJUST	1		D		
13	485-25040-200	SPRING,ADJUST,HIGH	1		D		
14	467-25003-200	SCREW,SHUTTER	2		C		
15	488-25052-200	VALVE,THROTTLE	1		D		
17	491-25007-200	LEVER,THROTTLE	1		D		
18	489-25007-200	RING,STOP	1		C		
19	486-25040-200	SPRING,HIGH ADJUST	1		D		
20	464-25016-800	SHAFT,THROTTLE	1		D		
21	---	*SCREEN,INLET	1		C		
22	---	*DIAPHRAGM,PUMP	1		C		
23	---	*GASKET,PUMP	1		D		
24	575-25043-800	BODY,PUMP	1		D		
25	514-25001-200	SCREW,SET	1		D		
26	462-25016-200	SCREW,IDLE ADJUST	1		D		
27	463-25006-200	SPRING,IDLE ADJUST	1		D		

\* Contained in carb repair kit  
650-25001-910  
(Not available individually)

\* Indicates the part is included in a kit or assembly and is not available individually. Q=Quan. used  
C=Interchangeability S=Stocking code: A=Fast moving B=Med. fast C=Med. move D=Slow move  
E=N.L.A. F=Superseded or replaced by a new part

# FIG.5 HANDLE

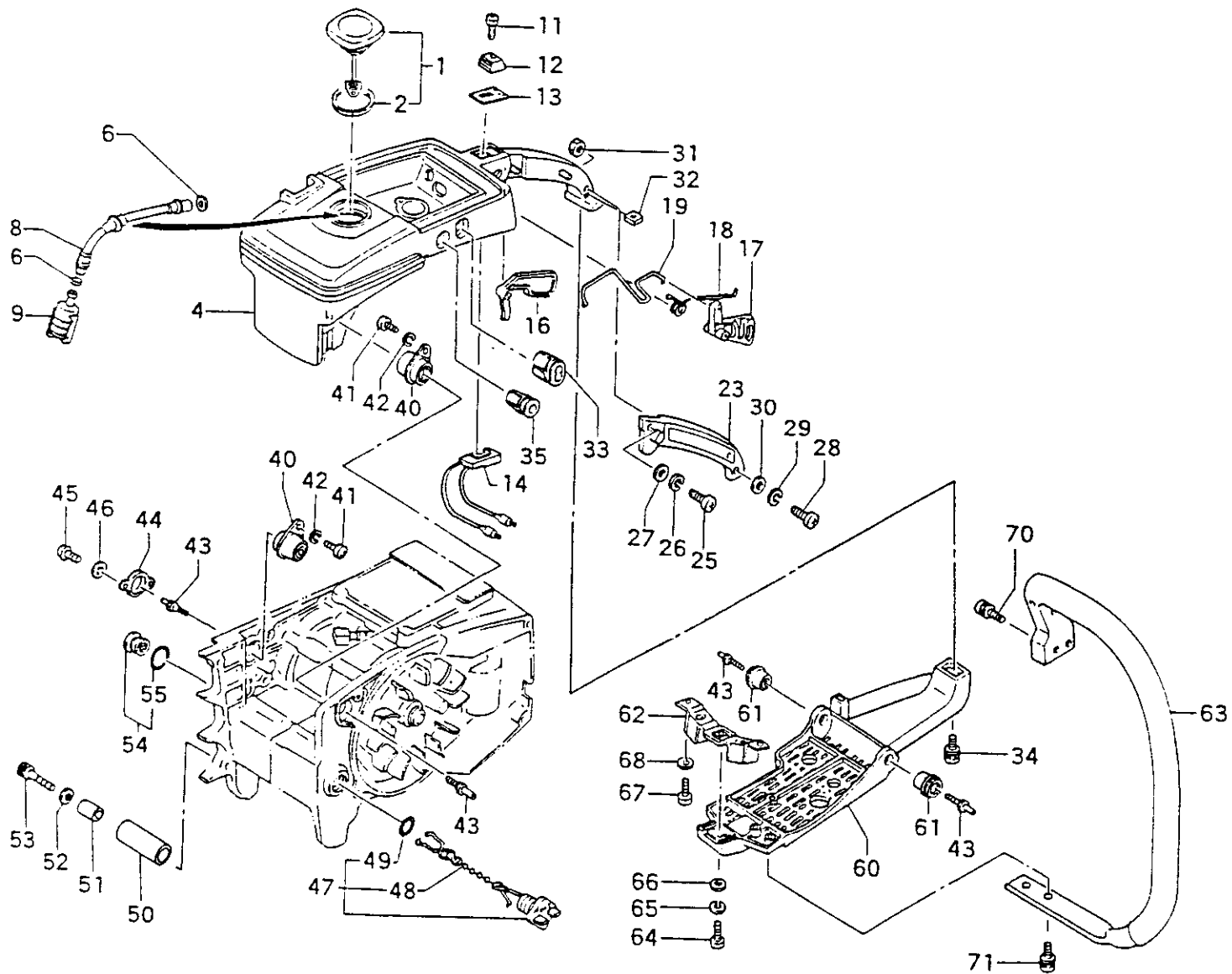

FIGURE 5

## ECS-4000/B PARTS LISTING

REF.	PART NO.	PART DESCRIPTION	Q	C	S	SERIAL NO.	REMARKS
1	635-32615-910	CAP,FUEL TANK ASS'Y	1		C		
2	642-11600-200	GASKET,TANK CAP	1		C		
4	010-32815-800	HANDLE,REAR,A	1		D		
6	680-04019-210	CLIP,7	2		B		
8	678-04080-201	PIPE,RUBBER	1		D		
9	675-04042-80	FILTER,FUEL	1		A		
11	990-11030-101	SCREW,3X10	1		A		
12	258-11650-20	BUTTON,STOP	1		C		
13	925-32530-200	DECAL,STOP BUTTON	1		C		
14	170-04080-800	BUTTON,STOP	1		D		
16	257-32810-200	LEVER,SAFETY	1		D		
17	060-32810-200	LEVER,THROTTLE	1		D		
18	061-32810-200	SPRING,THROTTLE LEVER	1		D		
19	490-32810-200	ROD,THROTTLE	1		D		
23	011-32810-800	HANDLE,REAR,B	1		D		
25	990-11040-301	SCREW,4X30	1		D		
26	992-10040-012	WASHER,S,4	1		D		
27	992-00040-011	WASHER,4	1		B		
28	990-11040-221	SCREW,4X22	2		B		
29	992-10040-012	WASHER,S,4	2		S		
30	992-00040-011	WASHER,4	2		B		
31	991-01040-011	NUT,4	3		C		
32	856-32810-200	NUT,SPECIAL	1		D		
33	190-32540-200	CAP,ADJUSTER	1		D		
34	994-15050-252	SCREW,PS,5X25	1		C		
35	191-32710-200	GROMMET	1		C		
40	219-32530-800	DAMPER	2		D		
41	990-11050-121	SCREW,5X12	2		A		
42	992-10050-012	WASHER,S,5	2		A		
43	295-32600-202	BOLT,DAMPER A	4		D		
44	224-32600-200	CAP,DAMPER	1		D		
45	990-11040-081	SCREW,4X8	2		C		
46	992-00040-011	WASHER,4	2		B		
47	642-32650-901	CAP,OIL ASS'Y	1		C		
48	625-32620-900	CAP,CHAIN,ASS'Y	1		D		
49	999-67020-000	O-RING,P20	1		C		
50	125-32540-200	CATCHER,CHAIN	1		D		
51	478-32540-200	COLLAR	1		D		
52	992-00050-011	WASHER,SMALL,5	1		C		

\* Indicates the part is included in a kit or assembly and is not available individually. Q=Quan. used  
C=Interchangeability S=Stocking code: A=Fast moving B=Med. fast C=Med. move D=Slow move  
E=N.L.A. F=Superseded or replaced by a new part

## ECS-4000/B PARTS LISTING

REF.	PART NO.	PART DESCRIPTION	Q	C	S	SERIAL NO.	REMARKS
53	990-51050-253	BOLT,HEX,5X25	1		B		
54	525-32530-900	CAP,OIL ASS'Y	1		D		
55	999-67020-000	O-RING,P20	1		C		
60	002-32810-800	BASE,ENGINE	1		D		
61	219-32600-821	DAMPER,FRONT	2		C		
62	266-32530-801	DAMPER,B	1		D		
63	209-32810-80	HANDLE,FRONT	1		C		
64	990-11050-141	SCREW,5X14	1		D		
65	992-10050-012	WASHER,S,5	1		A		
66	992-01050-011	WASHER,5	1		A		
67	990-11050-121	SCREW,5X12	2		A		
68	992-10050-012	WASHER,S,5	2		A		
70	994-15050-252	SCREW,PS,5X25	2		C		
71	994-15050-162	SCREW,5X16/PS	2		C		

\* Indicates the part is included in a kit or assembly and is not available individually. Q=Quan. used  
 C=Interchangeability S=Stocking code: A=Fast moving B=Med. fast C=Med. move D=Slow move  
 E=N.L.A. F=Superseded or replaced by a new part

**FIG.6 SIDE CASE**

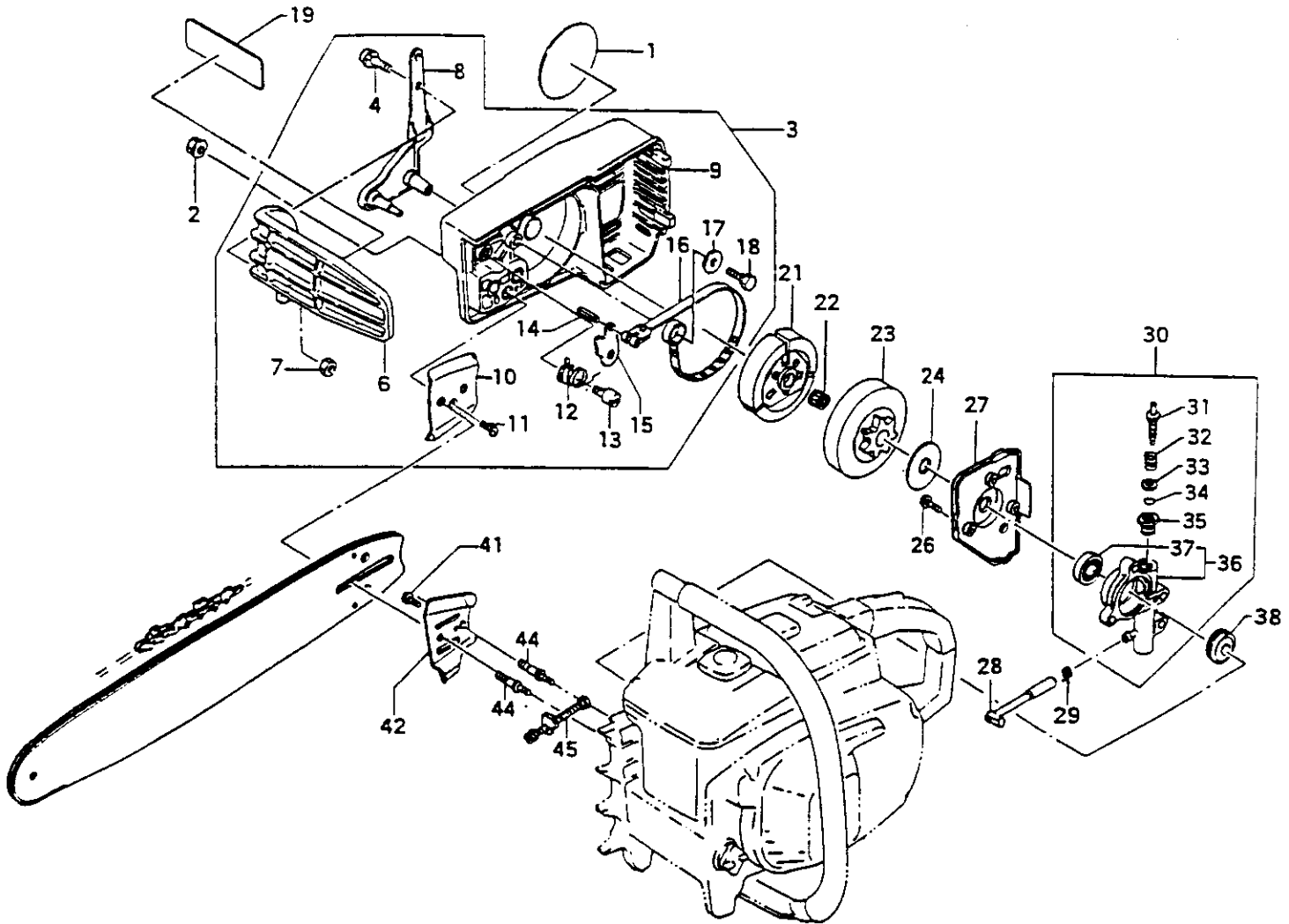

FIGURE 6

## ECS-4000/B PARTS LISTING

REF.	PART NO.	PART DESCRIPTION	Q	C	S	SERIAL NO.	REMARKS
1	906-32842-200	DECAL,ECS-4000B	1		D		
2	121-32530-200	NUT,CLAMP,BAR	2		B		
3	040-32818-910	CASE,SIDE ASS'Y	1		D		
4	994-14050-162	SCREW,S,5X16	2		C		
6	380-32529-200	HANDLE,BRAKE	1		D		
7	991-01050-011	NUT,5	2		A		
8	361-32750-810	LEVER,BRAKE	1		C		
9	040-32529-810	CASE,SIDE	1		C		
10	462-32525-200	PLATE,GUIDE B	1		C		
11	993-41040-101	SCREW,TAPPING,4X10	1		D		
12	374-32367-210	SPRING,BRAKE	1		D		
13	382-32750-200	BOLT,STEP,A	1		D		
14	993-24040-120	PIN,SPRING,4X12	1		D		
15	373-32771-200	ARM,BRAKE	1		C		
16	378-32529-800	BAND,BRAKE	1		D		
17	368-32057-200	WASHER,BRAKE SHAFT	1		C		
18	383-32367-210	BOLT,STEP,B	1		D		
19	907-32842-210	DECAL,ECS-4000B	1		D		
21	287-01801-801	CLUTCH	1		D		
22	999-62101-301	BEARING,NEEDLE,101310	1		B		
23	310-01857-810	HOUSING,CLUTCH,.325"	1		B		
24	358-04050-201	WASHER,CLUTCH	1		D		
26	990-11050-221	SCREW,5X22	3		B		
27	097-32530-810	COVER,OIL PUMP	1		D		
28	515-32530-221	PIPE,OIL,A	1		D		
29	680-04060-200	CLIP,6.8	1		D		
30	088-32530-910	CASE,OIL PUMP ASS'Y	1		D		
31	501-32530-201	PUMP,ADJUSTER OIL	1		D		
32	502-32550-200	SPRING,ADJUSTER	1		D		
33	992-01050-011	WASHER,5	1		A		
34	999-67005-000	O-RING,P5	1		D		
35	503-32550-200	CAP,ADJUST,OIL PUMP	1		D		
36	145-32530-800	PUMP,OIL	1		D		
37	999-66132-420	SEAL,OIL,#AC13246	1		D		
38	084-32350-200	GEAR,SCREW	1		D		
41	990-11040-081	SCREW,4X8	1		C		
42	461-32540-200	PLATE,GUIDE A	1		C		
44	101-32530-200	BOLT,STUD,BAR/CHAIN	2		C		
45	116-32382-900	BOLT,TENSION,CHAIN,ASS'Y	1		B		

\* Indicates the part is included in a kit or assembly and is not available individually. Q=Quan. used  
C=Interchangeability S=Stocking code: A=Fast moving B=Med. fast C=Med. move D=Slow move  
E=N.L.A. F=Superseded or replaced by a new part

# FIG.7 TOOLS & OPTIONAL PARTS

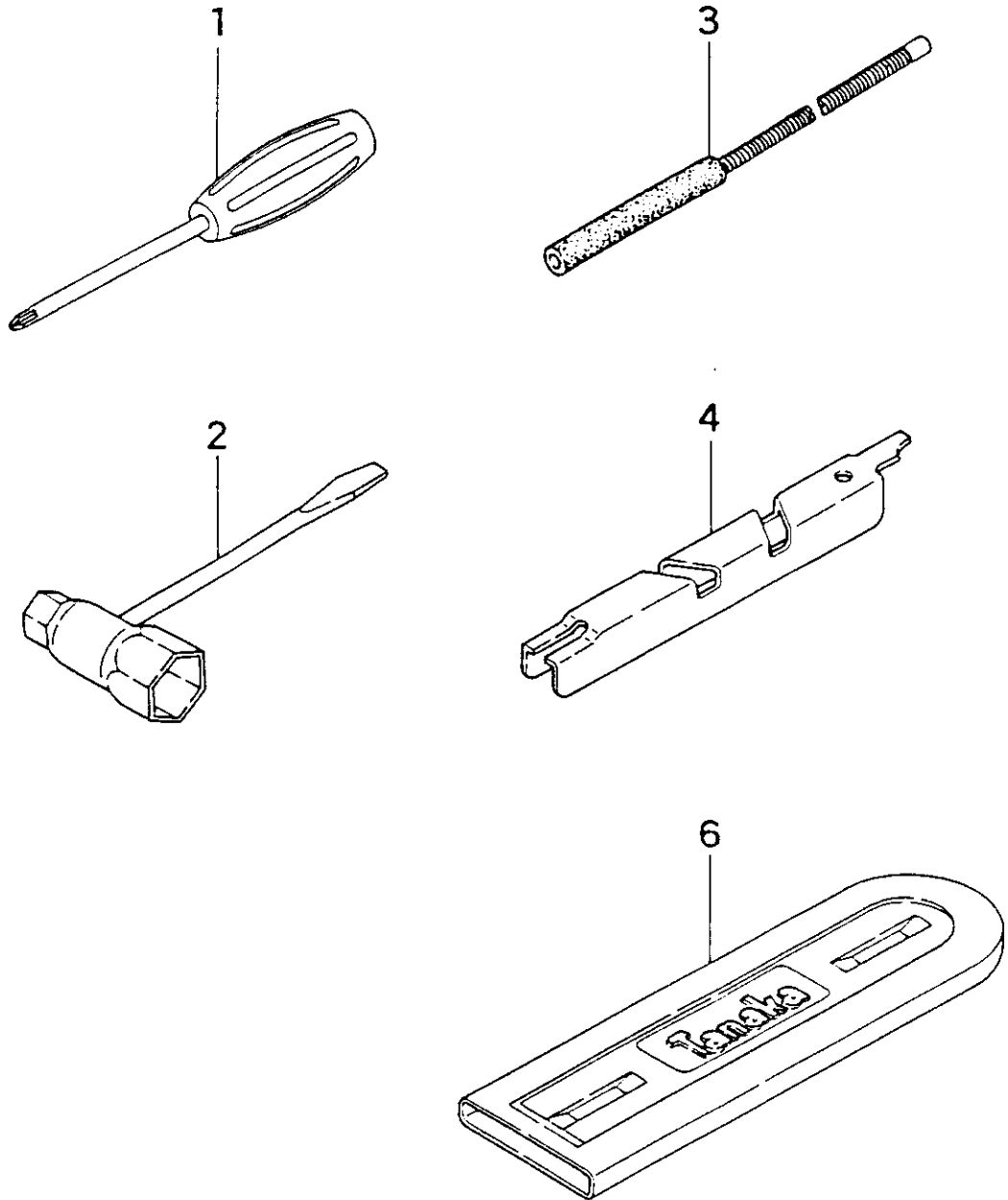

FIGURE 7

## ECS-4000/B PARTS LISTING

REF.	PART NO.	PART DESCRIPTION	Q	C	S	SERIAL NO.	REMARKS
1	862-20000-200	SCREW DRIVER,PHILLIPS	1		D		
2	013-29325-400	SPANNER,BOX,10X19	1		C		
3	CSF-450	FILE,ROUND,4.5MM	1		D		
4	CDG-300	GUAGE,DEPTH	1		D		
6	BCC-160	COVER,BAR/CHAIN,16"	1		D		



## Free Manuals Download Website

<http://myh66.com>

<http://usermanuals.us>

<http://www.somanuals.com>

<http://www.4manuals.cc>

<http://www.manual-lib.com>

<http://www.404manual.com>

<http://www.luxmanual.com>

<http://aubethermostatmanual.com>

Golf course search by state

<http://golfingnear.com>

Email search by domain

<http://emailbydomain.com>

Auto manuals search

<http://auto.somanuals.com>

TV manuals search

<http://tv.somanuals.com>