

Tanaka

Parts Catalog

Chainsaw

Model: ECS-506

Units Prior To Serial No. F 102250

FIG.1 ENGINE

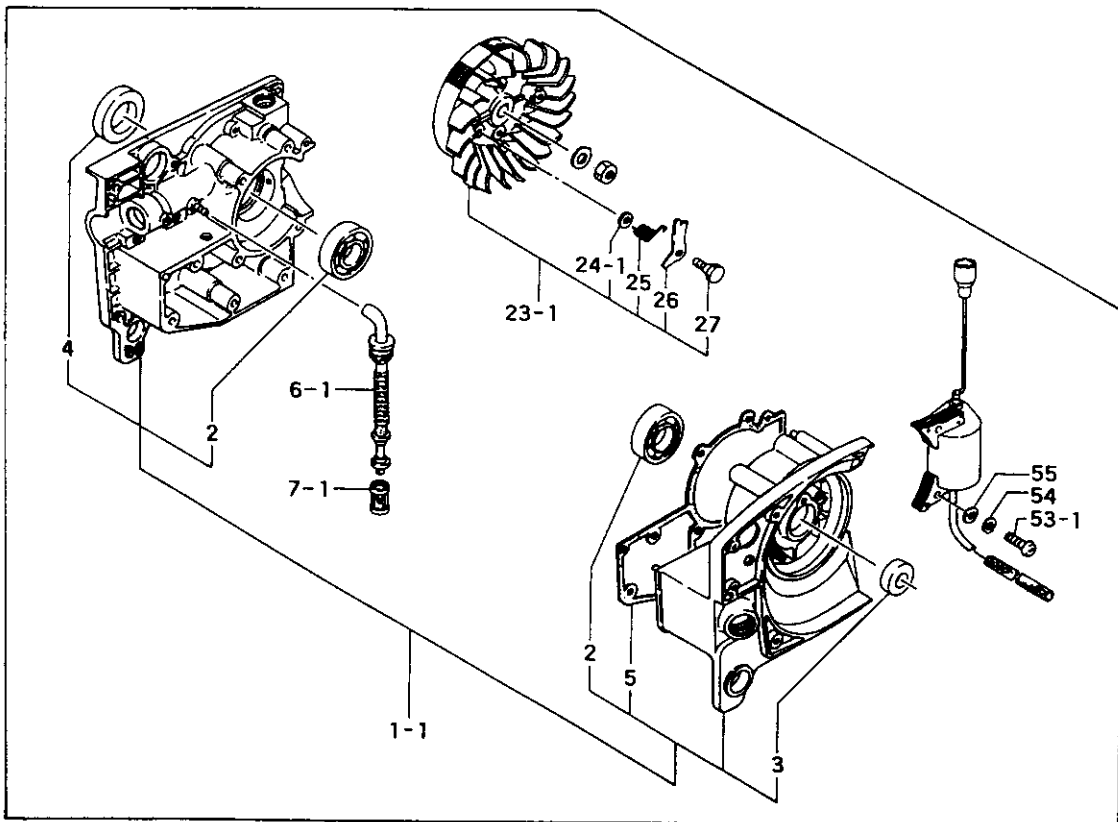
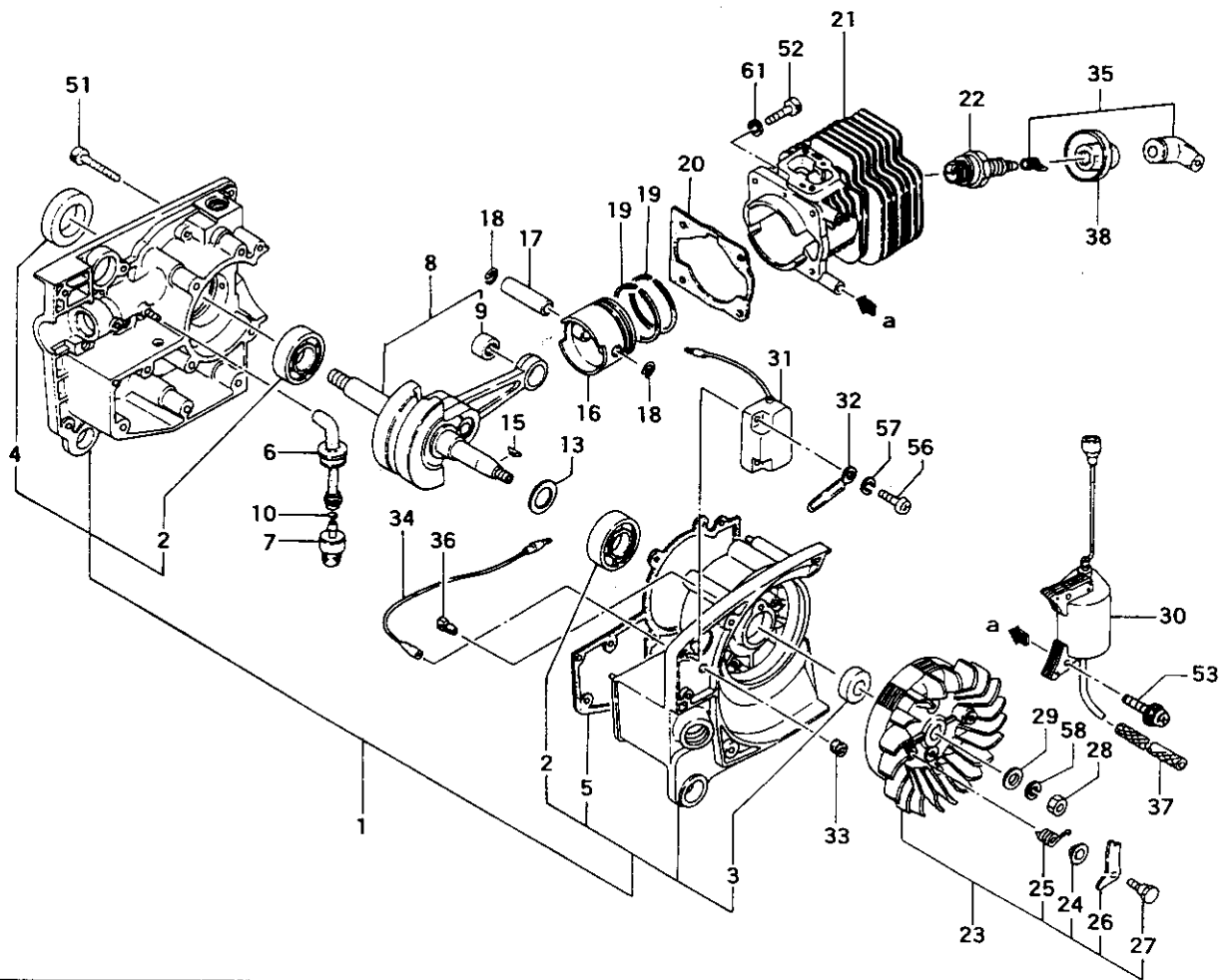

REF. NBR	PART NBR	PART NAME	QTY	SERIAL NBR	REMARKS
1-001, 1	072-11800-921	CRANK CASE ASS'Y	1	-C187438	
1-001	072-11800-930	CRANK CASE ASS'Y	1	N -E113591	
1-001	072-11800-930	CRANK CASE ASS'Y	1	I -E113591	
1-001	072-11800-931	CRANK CASE ASS'Y	1	E113592-	
1-002	999-81820-206	BALL BEARING #6202, 35MM/OD	2		
1-003	999-66122-200	OIL SEAL 12227	1		
1-004	999-66253-512	OIL SEAL 25356	1		
1-005	090-11850-200	CRANK CASE GASKET	1		
1-006, 1	505-32800-201	OIL PIPE B	1	-C187438	
1-006	505-32800-210	OIL PIPE B	1	N -E113591	
1-006	505-32800-210	OIL PIPE B	1	R -E113591	
1-006	505-32800-211	OIL PIPE B	1	E113592-	
1-007, 1	487-32600-200	OIL FILTER NET	1	-C187438	
1-007	488-32530-800	OIL FILTER BODY COMP.	1	N C187437-	
1-008	046-11600-803	CRANK SHAFT COMP.	1	R -C187438	
1-008	046-11600-804	CRANK SHAFT COMP.	1	R -D275496	
1-008	046-11600-805	CRANK SHAFT COMP.	1	N	
1-008	046-11600-806	CRANK SHAFT COMP.	1	D275497-	
1-009	999-62101-004	NEEDLE BEARING F1010B	1		
1-010	680-04019-210	CLIP 7	1	N C187437-	
1-013	071-02007-200	CRANK SHAFT SHIM 0.05	V	D C187437-	
1-013	071-02007-210	CRANK SHAFT SHIM 0.10	V	D C187437-	
1-013	071-02007-220	CRANK SHAFT SHIM 0.15	V	D C187437-	
1-013	071-02007-230	CRANK SHAFT SHIM 0.20	V	R -C187438	
1-013	071-11600-230	CRANK SHAFT SHIM 0.20	V	C187437-	
1-013	071-02007-240	CRANK SHAFT SHIM 0.30	V	R -C187438	
1-013	071-11600-240	CRANK SHAFT SHIM 0.30	V	C187437-	
1-015	068-10100-200	WOOD-RUFF KEY 3X13X4.5	1		
1-016	031-10100-210	PISTON	1		
1-017	037-10100-200	PISTON PIN 10X35	1		
1-018	039-02000-201	PISTON PIN CIRCLIP	2		
1-019	041-10100-201	PISTON RING	2		
1-020	017-11600-211	CYLINDER GASKET	1		
1-021	002-11600-222	CYLINDER	1		
1-022	018-11610-200	SPARK PLUG BPM-7A	1		
1-023, 1	155-20752-900	MAGNETO ROTOR ASS'Y	1	R -C187438	
1-023, 1	155-20752-901	MAGNETO ROTOR ASS'Y	1	R -E113591	
1-023	155-20752-902	MAGNETO ROTOR ASS'Y	1	E113592-	
1-024, 1	786-00601-200	STARTER PAVL WASHER	2	R -E113591	
1-024	786-11620-200	STARTER PAVL WASHER	2	E113592-	
1-025	790-11600-200	STARTER PAVL SPRING	2		
1-026	788-11600-210	STARTER PAVL	2		
1-027	793-10200-201	STEP BOLT	2		
1-028	066-00601-200	FLYWHEEL NUT	1		
1-029	065-00000-200	FLYWHEEL WASHER	1		
1-030	167-21509-800	IGNITION COIL COMP.	1	-D275496	
1-030	167-20761-800	IGNITION COIL COMP.	1	P D275497-	
1-031	159-21401-871	IGNITOR COMP. TTI-1E	1	R -D146126	
1-031	159-21401-870	IGNITOR COMP. TTI-1D	1	R -E113591	
1-031	159-21409-870	IGNITOR TTI-5D	1	R -E312740	
1-031	159-21411-870	IGNITOR COMP. TTI-6D	1	E312741-	
1-032	198-11660-800	CORD CLAMP COMP.	1	R -C187438	
1-032	198-11600-800	CORD CLAMP COMP.	1	C187437-	
1-033	203-04015-202	PRIMARY CORD GROMMET	1	N E055716-	
1-034	173-11600-810	PRIMARY CORD COMP.	1	R -D146126	
1-034	173-11600-800	PRIMARY CORD COMP., B265M	1	D146127-	
1-035	157-04000-900	SPARK PLUG CAP ASS'Y	1		
1-036	198-11600-200	CORD CLAMP	1		
1-037	755-32600-200	CORD INSULATOR TUBE	1		
1-038	255-11850-200	SPARK PLUG RUBBER CAP	1		
1-051	990-51050-303	HEX. HOLE BOLT 5X30	8		
1-052	990-51050-203	HEX. HOLE BOLT 5X20	4		
1-053, 1	990-11040-181	SCREW 4X18	2	N	

- To be cont'd -

REF. NBR	PART NBR	PART NAME	QTY	SERIAL NBR	REMARKS
1-053	994-16040-186	HIGH TENSION SCREW 4X18VS	2		
1-054	992-10040-012	S.WASHER 4	2	M	
1-055	992-00040-011	SMALL WASHER 4	2	M	
1-056	990-11040-161	SCREW 4X16	2		
1-057	992-10040-012	S.WASHER 4	2		
1-058	992-10070-012	S.WASHER 7	1		
1-061	992-10050-012	S.WASHER 5	4		

FIG.2 CLUTCH, BRAKE & MUFFLER

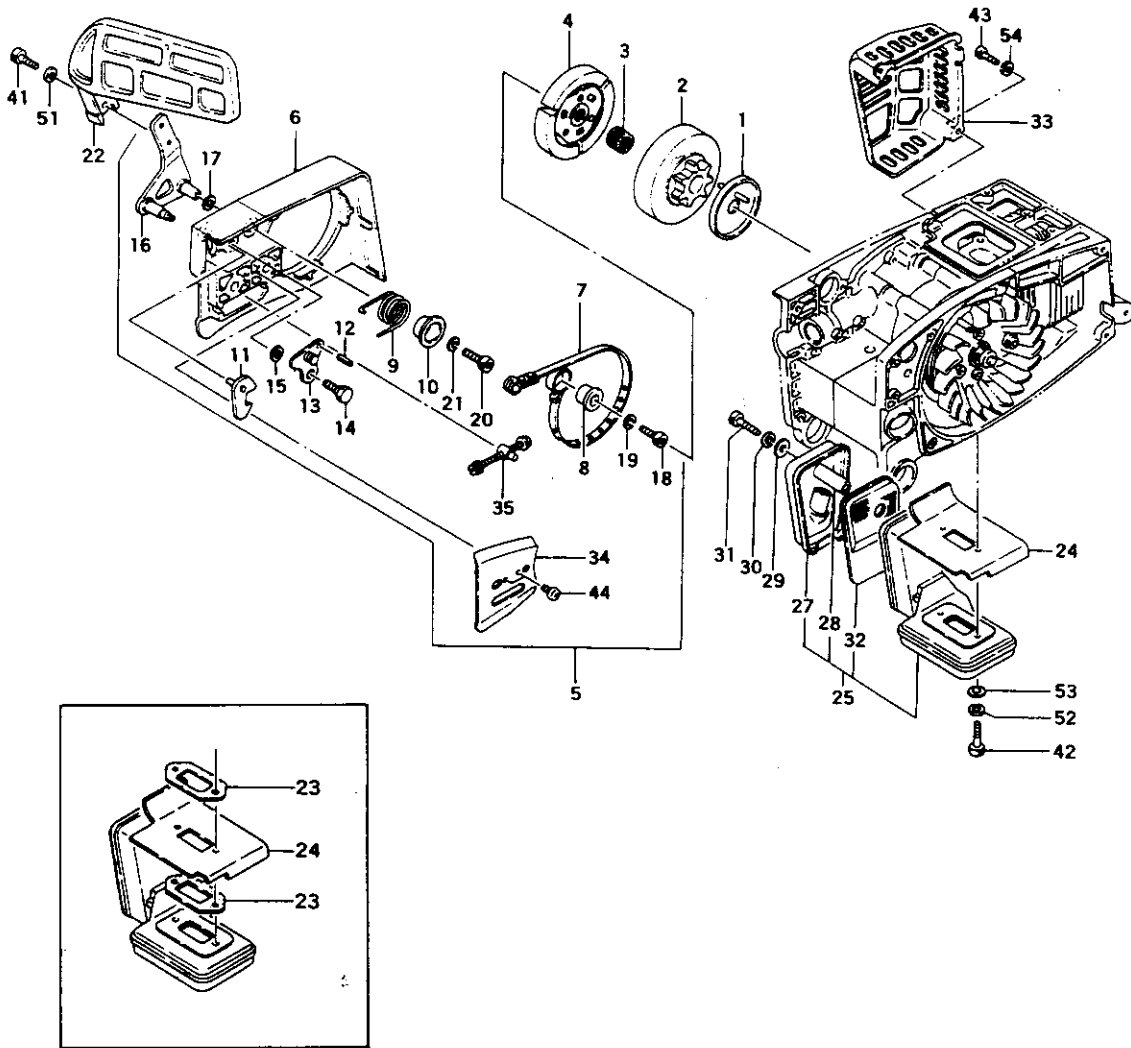

REF. NBR	PART NBR	PART NAME	QTY	SERIAL NBR	REMARKS
2-001	321-32600-800	SPROCKET WASHER COMP.	1	R -C187438	
2-001	321-32600-801	SPROCKET WASHER COMP.	1	R -C234905	
2-001	321-32600-802	SPROCKET WASHER COMP.	1	I -E113591	
2-001	321-32600-803	SPROCKET WASHER COMP.	1	E113592-	
2-002	310-11600-801	CLUTCH HOUSING COMP.	1		
2-003	999-62121-507	NEEDLE BEARING 121512	1		
2-004	287-11600-800	CLUTCH COMP.	1	R -E312740	
2-004	287-11600-801	CLUTCH COMP.	1	E312741-	
2-005	040-32600-910	SIDE CASE ASS'Y	1		
2-006	040-32600-210	SIDE CASE	1		
2-007	378-32600-802	BRAKE BAND COMP.	1		
2-008	381-32600-200	BRAKE BAND BOSS METAL	1		
2-009	374-32600-201	BRAKE SPRING	1	R -F102050	
2-009	374-32600-210	BRAKE SPRING	1	F102051-	
2-010	368-32600-200	BRAKE SHAFT WASHER	1		
2-011	360-32600-800	BRAKE RESET PLATE COMP.	1		
2-012	993-24005-120	SPRING PIN 5X12	1		
2-013	373-32600-801	BRAKE ARM COMP.	1		
2-014	382-32600-200	STEP BOLT A	1		
2-015	871-32600-200	SPECIAL WASHER B	1		
2-016	361-32600-801	BRAKE LEVER COMP.	1		
2-017	034-31200-250	IMPELLER SHAFT SHIM 0.5	1		
2-018	990-51050-123	HEX. HOLE BOLT 5X12	1		
2-019	992-10050-012	S.WASHER 5	1		
2-020	990-51050-103	HEX. HOLE BOLT 5X10	1		
2-021	992-10050-012	S.WASHER 5	1		
2-022	380-32600-803	BRAKE HANDLE COMP.	1		
2-023	737-11600-210	MUFFLER GASKET F	2	D C187437-	
2-024	744-11600-210	MUFFLER BRACKET	1	R -C187436	
2-024	744-11600-211	MUFFLER BRACKET	1	C187437-	
2-025	705-11603-930	MUFFLER ASS'Y	1		
2-027	717-11603-812	MUFFLER BODY B COMP.	1		
2-028	740-11603-210	MUFFLER CLAMP COLLAR 30	1		
2-029	368-32350-200	BRAKE SHAFT WASHER	1		
2-030	992-10050-012	S.WASHER 5	1		
2-031	990-51050-453	HEX. HOLE BOLT 5X45	1		
2-032	732-11603-201	PARTITION NET	1		
2-033	738-11600-202	MUFFLER PROTECTOR	1	R -D145326	
2-033	738-11600-203	MUFFLER PROTECTOR	1	D145327-	
2-034	462-32600-201	GUIDE PLATE B	1		
2-035	118-32600-901	TENSION ADJUSTMENT BOLT ASS'Y	1		
2-041	990-51050-103	HEX. HOLE BOLT 5X10	2		
2-042	990-51050-453	HEX. HOLE BOLT 5X45	2	-D275496	
2-042	990-51050-353	HEX. HOLE BOLT 5X35	2	N D275497-	
2-043	990-51050-103	HEX. HOLE BOLT 5X10	1		
2-044	990-11030-061	SCREW 3X6	2		
2-051	992-10050-012	S.WASHER 5	2		
2-052	992-10050-012	S.WASHER 5	2		
2-053	992-00050-011	SMALL WASHER 5	2		
2-054	992-00050-011	SMALL WASHER 5	1		

FIG.3 CLEANER & CARBURETOR

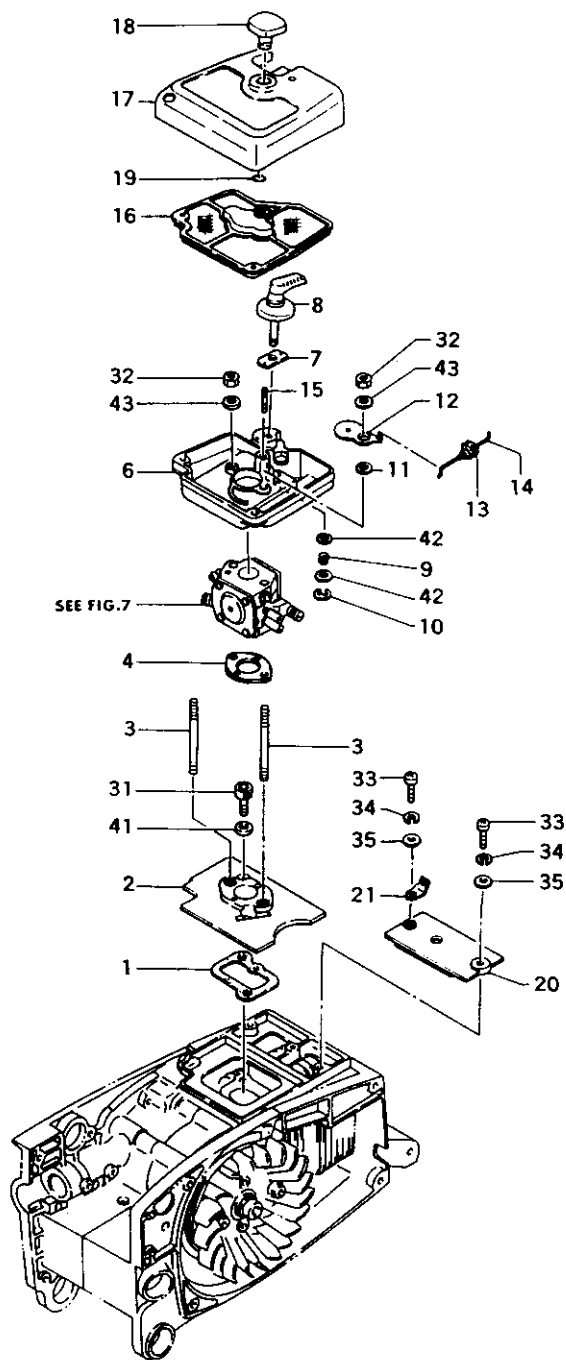

REF. NBR	PART NBR	PART NAME	QTY	SERIAL NBR	REMARKS
3-001	403-11600-200	INLET MANIFOLD GASKET	1	I -E113591	
3-001	403-11600-201	INLET MANIFOLD GASKET	1	R -E312740	
3-001	403-11600-202	INLET MANIFOLD GASKET	1	E312741-	
3-002	404-11600-811	CARBURETOR INSULATOR COMP.	1		
3-003	100-0075B-202	STUD BOLT 5X58	2		
3-004	402-11650-200	CARBURETOR GASKET	1		
3-008	423-11600-203	CLEANER BODY	1	I -E312740	
3-006	423-11600-204	CLEANER BODY	1	E312741-	
3-007	710-32600-201	CHOKE SET PLATE	1		
3-008	704-32650-800	CHOKE BUTTON COMP.	1		
3-009	308-36100-201	ADJUSTER SPRING A	1		
3-010	993-55040-001	STOP RING	1		
3-011	708-32350-200	CHOKE VALVE SHIM	1		
3-012	700-32600-211	CHOKE VALVE	1		
3-013	707-32600-200	CHOKE ROD HOLDER RUBBER	1		
3-014	708-32600-210	CHOKE ROD	1		
3-015	100-11601-200	STUD BOLT 4X21	1	R -E113591	
3-015	100-11601-201	STUD BOLT 4X21	1	E113592-	
3-016	420-11600-801	CLEANER ELEMENT COMP.	1	R -E113591	
3-016	420-11600-810	CLEANER ELEMENT COMP.	1	E113592-	
3-017	051-32610-211	CLEANER COVER	1	R -E113591	
3-017	051-32610-220	CLEANER COVER	1	E113592-	
3-018	175-32600-801	CLEANER KNOB COMP.	1		
3-019	999-67008-000	O-RING P-8	1		
3-020	186-32600-210	SHUTTER PLATE	1		
3-021	205-11600-201	TERMINAL TAB	1		
3-031	990-51050-253	HEX. HOLE BOLT 5X25	2		
3-032	991-74050-011	U NUT 5	2	I -E113591	
3-032	991-74050-010	U-NUT 5	2	E113592-	
3-033	990-11040-121	SCREW 4X12	2		
3-034	992-10040-012	S. WASHER 4	2		
3-035	992-00040-011	SMALL WASHER 4	2		
3-041	992-10050-012	S. WASHER 5	2		
3-042	992-00080-011	SMALL WASHER 6	2		
3-043	992-01050-011	WASHER 5	2		

FIG.4 RECOIL STARTER

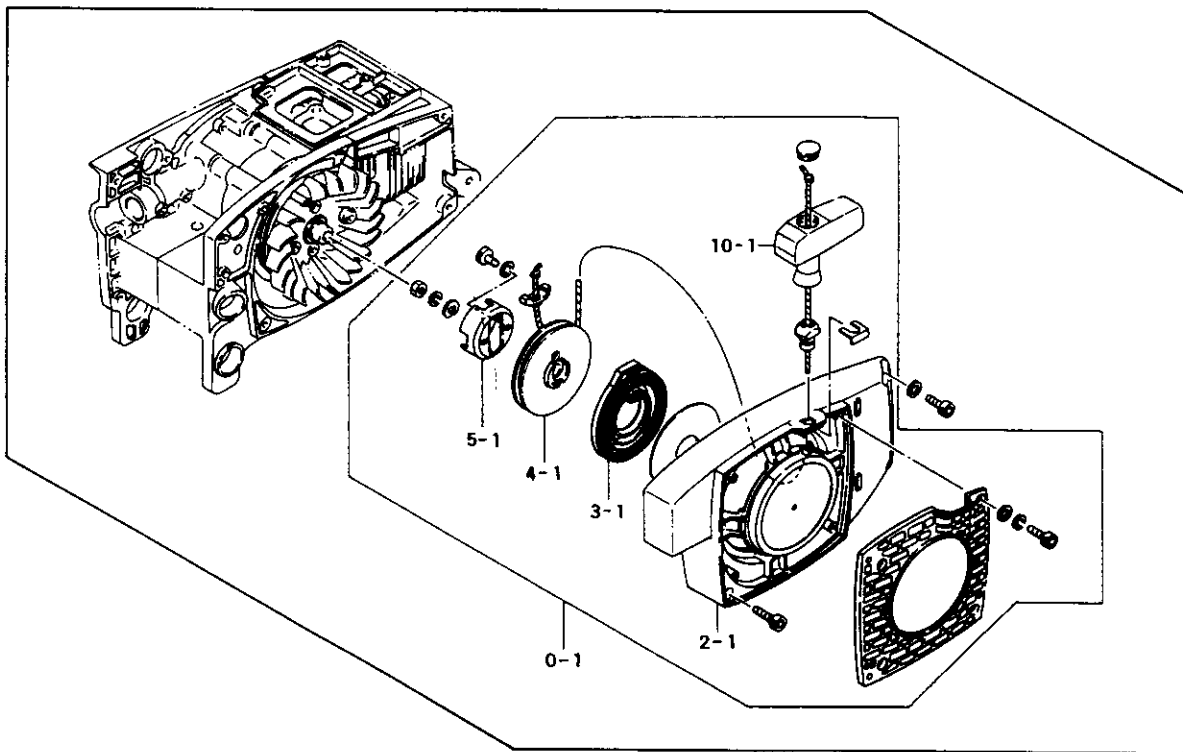
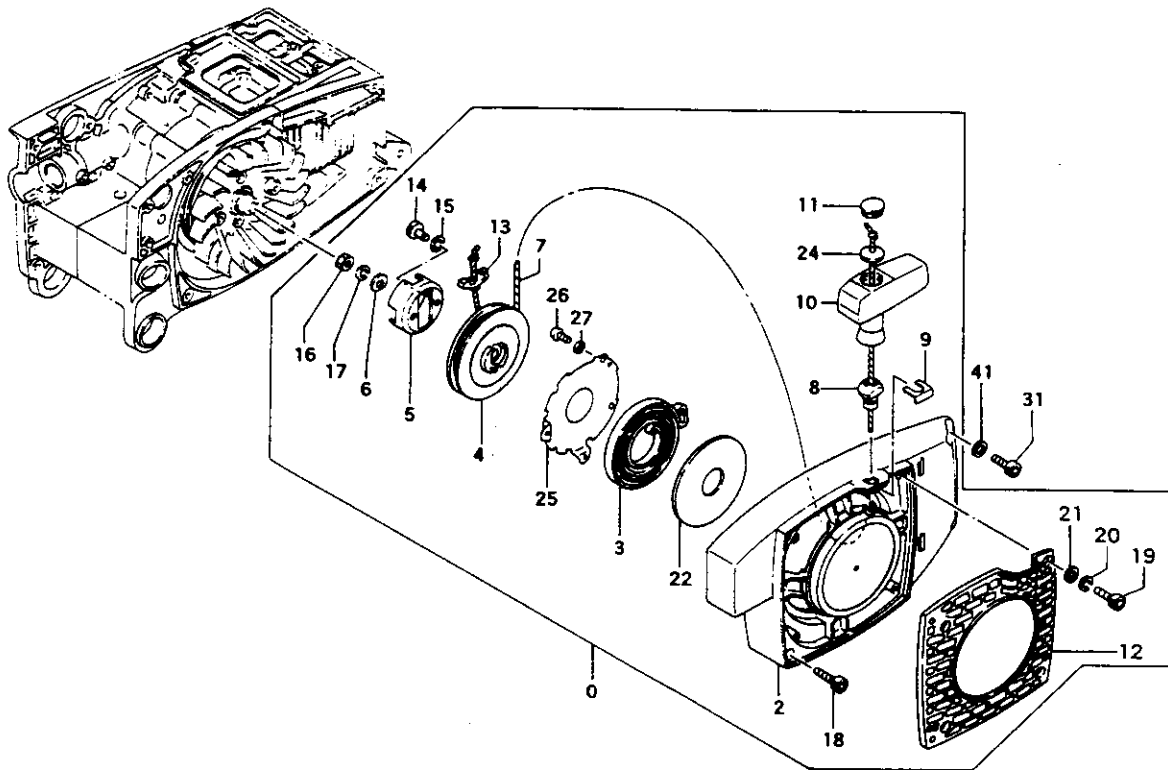

REF. NBR	PART NBR	PART NAME	QTY	SERIAL NBR	REMARKS
4-000.1	756-11600-902	RECOIL STARTER ASS'Y	1 R	-C187436	
4-000.1	756-11600-903	RECOIL STARTER ASS'Y	1 R	-C187436	
4-000.1	756-11600-904	RECOIL STARTER ASS'Y	1 R	-E312740	
4-000	756-11600-905	RECOIL STARTER ASS'Y	1	E312741-	
4-002.1	112-11600-803	FAN CASE COMP.	1 R	-C187436	
4-002.1	112-11600-804	FAN CASE COMP.	1 R	-E312740	
4-002	112-11600-805	FAN CASE COMP.	1	E312741-	
4-003.1	778-11600-910	RECOIL SPRING CASE ASS'Y	1 R	-C187436	
4-003.1	778-11600-911	RECOIL SPRING CASE ASS'Y	1	-E312740	
4-003	779-11620-200	RECOIL SPRING	1 N	E312741-	
4-004.1	774-11600-812	STARTER ROPE REEL	1 R	-E312740	
4-004	774-11600-820	STARTER ROPE REEL	1	E312741-	
4-005.1	773-11600-200	PULLEY SHAFT/OUTER	1 R	-E113591	
4-005	773-11600-201	PULLEY SHAFT/OUTER	1	E113592-	
4-006	182-11600-200	SPECIAL WASHER 5	1		
4-007	783-11600-202	ROPE	1		
4-008	780-11600-201	ROPE GUIDE	1		
4-009	781-11600-200	HANDLE GUIDE HOLDER METAL	1		
4-010.1	785-11600-201	STARTER HANDLE	1 R	-C187436	
4-010	785-11600-202	STARTER HANDLE	1	C187437-	
4-011	833-10207-200	STARTER HANDLE CAP	1		
4-012	805-32600-202	PROTECTION COVER	1		
4-013	782-11600-200	ROPE RECEIVER	1		
4-014	990-51040-103	HEX. HOLE BOLT 4X10	2		
4-015	992-10040-012	S.WASHER 4	2		
4-016	991-01050-013	NUT 5	1		
4-017	992-10050-012	S.WASHER 5	1		
4-018	990-51050-223	HEX. HOLE BOLT 5X22	2		
4-019	990-51040-123	HEX. HOLE BOLT 4X12	4		
4-020	992-10040-012	S.WASHER 4	4		
4-021	992-00040-011	SMALL WASHER 4	4		
4-022	827-11660-200	RECOIL SPRING CASE COVER	1		
4-024	795-11600-200	ROPE STOPPER	1 N	C187437-	
4-025	778-11622-200	STARTER PANEL	1 N	E312741-	
4-026	990-11030-061	SCREW 3X6	3 N	E312741-	
4-027	992-10030-012	S.WASHER 3	3 N	E312741-	
4-031	990-51050-153	HEX. HOLE BOLT 5X15	2		
4-041	992-00050-011	SMALL WASHER 5	2		

FIG.5 REAR HANDLE

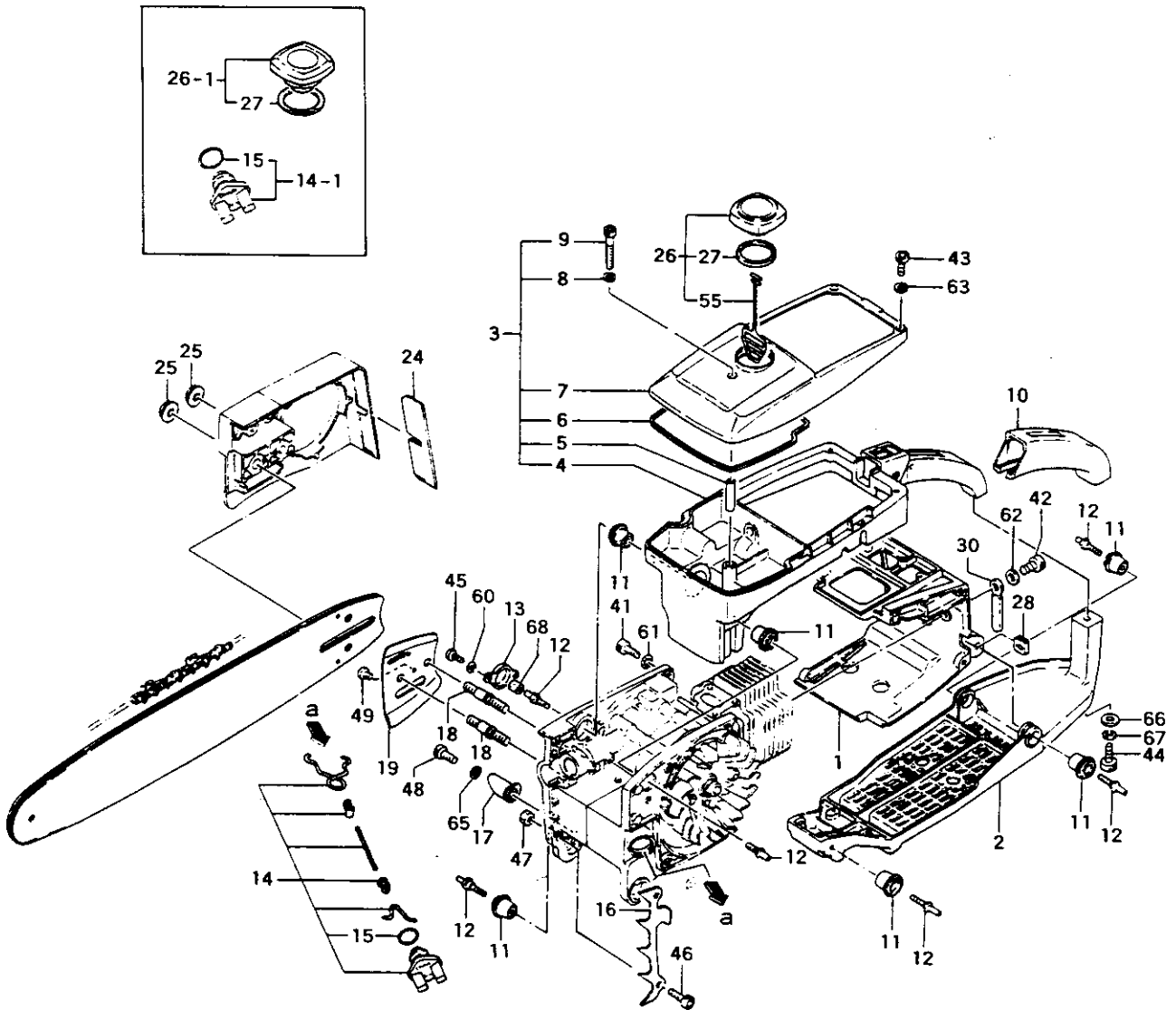

REF. NBR	PART NBR	PART NAME	QTY	SERIAL NBR	REMARKS
5-001	016-11600-211	CYLINDER COVER	1	-C187436	
5-001	016-11600-212	CYLINDER COVER	1	M C187437-	
5-002	002-32600-211	ENGINE BASE	1	R -C187436	
5-002	002-32600-212	ENGINE BASE	1	I -E312740	
5-002	002-32600-213	ENGINE BASE	1	E312741-	
5-003	010-32600-910	REAR HANDLE A ASS'Y	1		
5-004	010-32600-211	REAR HANDLE A	1		
5-005	096-11600-200	COLLAR	1		
5-006	605-32600-201	TANK GASKET	1		
5-007	600-32600-203	TANK COVER	1		
5-008	317-11401-200	GROMMET GASKET	1		
5-009	990-51050-453	HEX. HOLE BOLT 5X45	1		
5-010	227-32600-211	REAR HANDLE GRIP	1	R -C187436	
5-010	227-32600-212	REAR HANDLE GRIP	1	C187437-	
5-011	219-32600-821	DAMPER COMP.	6		
5-012	295-32600-202	DAMPER SET BOLT A	6		
5-013	224-32600-200	DAMPER CAP	1		
5-014, 1	642-32600-901	OIL TANK CAP ASS'Y	1	R -C187436	
5-014	642-32650-900	OIL TANK CAP ASS'Y	1	R -E113591	
5-014	642-32650-901	OIL TANK CAP ASS'Y	1	E113592-	
5-015	999-67020-000	O-RING P-20	1		
5-016	460-32650-200	SPIKE	1		
5-017	125-32600-201	CHAIN CATCHER	1		
5-018	101-32600-200	CHAIN BAR CLAMP BOLT	2		
5-019	461-32600-202	GUIDE PLATE A	1		
5-024	325-32600-201	CHAIN PROTECT PLATE	1		
5-025	121-32600-200	CHAIN BAR CLAMP NUT	2		
5-026, 1	635-32600-911	TANK CAP ASS'Y	1	R -C187436	
5-026	635-32615-900	FUEL TANK CAP ASS'Y	1	C187437-	
5-027	642-11600-200	TANK CAP GASKET	1		
5-028	203-0604A-202	GROMMET	1	I -D177755	
5-028	203-10000-200	PRIMARY CORD GROMMET	1	D177756-	
5-030	198-11600-800	CORD CLAMP COMP.	1		
5-041	990-51050-153	HEX. HOLE BOLT 5X15	2		
5-042	990-51050-153	HEX. HOLE BOLT 5X15	2		
5-043	990-51040-103	HEX. HOLE BOLT 4X10	2		
5-044	990-51050-183	HEX. HOLE BOLT 5X18	1	-C187436	
5-044	990-51050-203	HEX. HOLE BOLT 5X20	1	M C187437-	
5-045	990-11040-081	SCREW 4X8	2		
5-046	990-51050-123	HEX. HOLE BOLT 5X12	2		
5-047	991-74050-010	U-NUT 5	1		
5-048	990-51050-183	HEX. HOLE BOLT 5X18	1		
5-049	990-11040-081	SCREW 4X8	1		
5-055	626-32550-200	TANK CAP CHAIN	1	N C187437-	
5-055	626-32550-200	TANK CAP CHAIN	1	R -D177755	
5-055	626-32550-201	TANK CAP CHAIN	1	D177756-	
5-060	992-10040-012	S.WASHER 4	2		
5-061	992-00050-011	SMALL WASHER 5	2		
5-062	992-00050-011	SMALL WASHER 5	2		
5-063	992-00040-011	SMALL WASHER 4	2		
5-065	992-00050-011	SMALL WASHER 5	1	N C187437-	
5-066	992-00050-011	SMALL WASHER 5	1	N C187437-	
5-067	992-10050-012	S.WASHER 5	1	N C187437-	
5-068	700-15008-014	RUBBER PIPE	1	N C208934-	

FIG.6 OIL PUMP & HANDLE

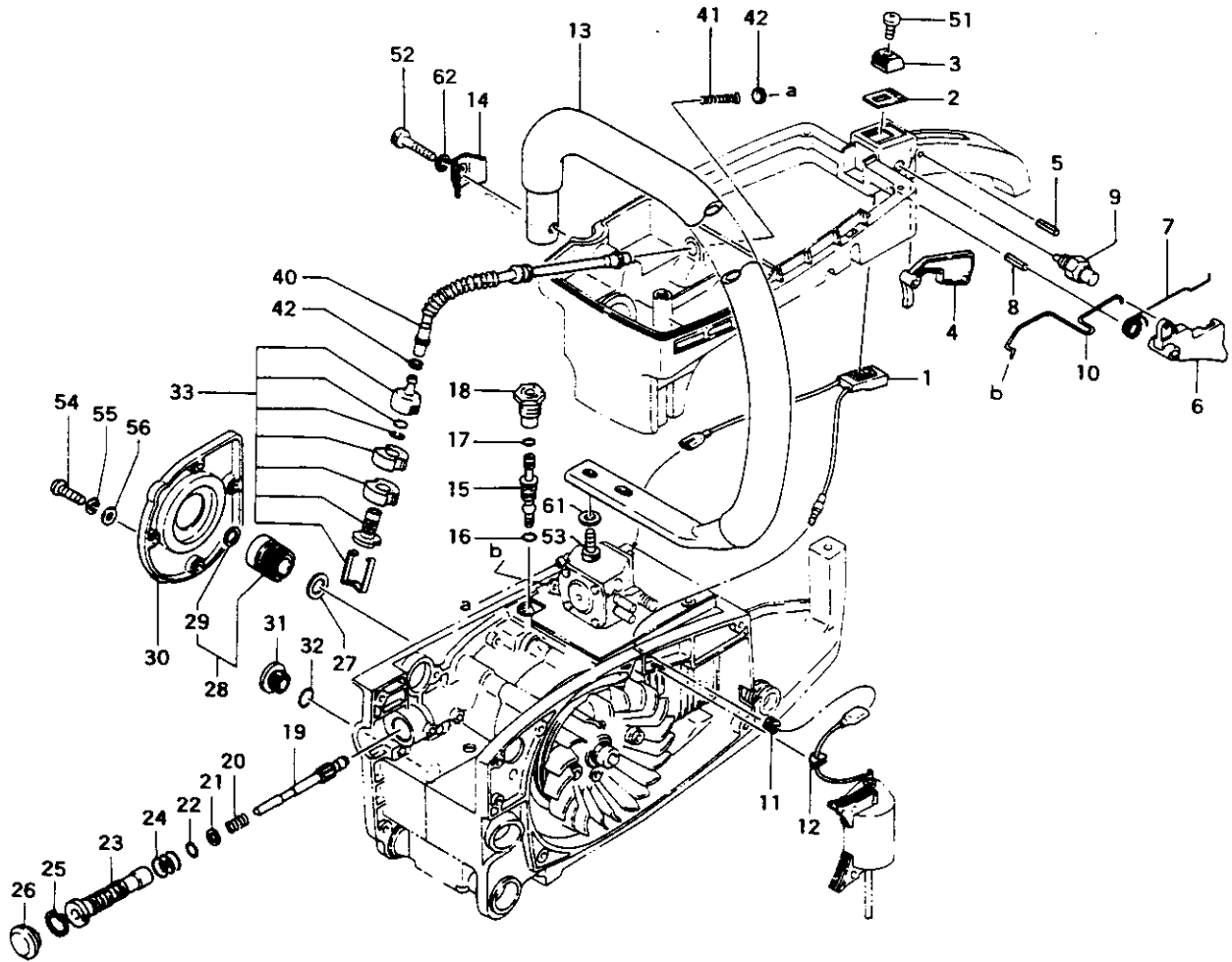

REF. NBR	PART NBR	PART NAME	QTY	SERIAL NBR	REMARKS
6-001	170-11600-801	STOP BUTTON COMP.	1	-F102050	
6-001	170-11600-802	STOP BUTTON COMP.	1	F102051-	
6-002	925-32600-200	STOP BUTTON MARK	1		
6-003	258-11600-200	BUTTON STOP	1		
6-004	257-32600-201	SAFETY LEVER	1		
6-005	993-24004-180	SPRING PIN 4X18	1		
6-006	060-32600-211	THROTTLE LEVER	1		
6-007	061-32600-200	THROTTLE LEVER SPRING	1	R -F102050	
6-007	061-32600-201	THROTTLE LEVER SPRING	1	F102051-	
6-008	993-26005-254	SPRING PIN 5X25	1		
6-009	064-33225-800	PUSH PIN COMP.	1		
6-010	490-32650-201	THROTTLE ROD	1		
6-011	203-04015-202	PRIMARY CORD GROMMET	1	-E159600	
6-011	203-04015-202	PRIMARY CORD GROMMET	2	E159601-	
6-012	203-06000-200	PRIMARY CORD GROMMET	1	-C187436	
6-012	203-11880-200	PRIMARY CORD GROMMET	1	N C187437-	
6-013	209-32605-822	FRONT HANDLE COMP.	1	R -C187436	
6-013	209-32650-800	FRONT HANDLE COMP.	1	C187437-	
6-014	211-32600-200	FRONT HANDLE SUPPORT	1		
6-015	501-32600-210	OIL PUMP ADJUSTER	1		
6-016	999-67006-000	O-RING P-6	1		
6-017	999-67005-012	O-RING S-5	1		
6-018	503-32600-200	OIL PUMP ADJUSTER CAP	1		
6-019	085-32600-210	PUMP GEAR	1		
6-020	099-32600-201	PUMP GEAR SPRING	1	I -C187436	
6-020	099-32600-202	PUMP GEAR SPRING	1	C187437-	
6-021	870-32600-200	SPECIAL WASHER A	1		
6-022	999-67006-012	O-RING S-6	1		
6-023	071-32600-800	OIL PUMP CYLINDER COMP.	1		
6-024	999-67009-012	O-RING S-9	3		
6-025	993-51016-002	SNAP RING 16	1		
6-026	052-32500-200	RUBBER GROMMET	1		
6-027	430-32600-200	THRUST WASHER	1		
6-028	084-32600-902	SCREW GEAR ASS'Y	1	R -D145326	
6-028	084-32600-903	SCREW GEAR ASS'Y	1	D145327-	
6-029	999-66121-624	OIL SEAL 12162.5	1	R -D145326	
6-029	999-66121-626	OIL SEAL OS 12163	1	D145327-	
6-030	097-32600-210	OIL PUMP COVER	1		
6-031	525-32350-201	OIL LEVEL CAP	1	-C187436	
6-031	525-32530-200	OIL LEVEL CAP	1	N C187437-	
6-032	999-67012-500	O-RING P12.5	1	-C187436	
6-032	999-67020-000	O-RING P-20	1	N C187437-	
6-033	675-11610-901	PUMP FILTER BODY ASS'Y	1		
6-040	678-11650-201	RUBBER PIPE	1		
6-041	512-11600-200	PROTECTION COIL	1		
6-042	680-04019-210	CLIP 7	2		
6-051	994-31030-101	SCREW 3X10	1		
6-052	990-51080-353	HEX. HOLE BOLT 8X35	1		
6-053	990-51050-183	HEX. HOLE BOLT 5X18	2	R -C187436	
6-053	990-51050-153	HEX. HOLE BOLT 5X15	2	C187437-	
6-054	990-11040-101	SCREW 4X10	4		
6-055	992-10040-012	S. WASHER 4	4		
6-056	992-00040-011	SMALL WASHER 4	4		
6-061	992-01050-011	WASHER 5	2		
6-062	992-10080-012	S. WASHER 8	1		

FIG.7 CARBURETOR

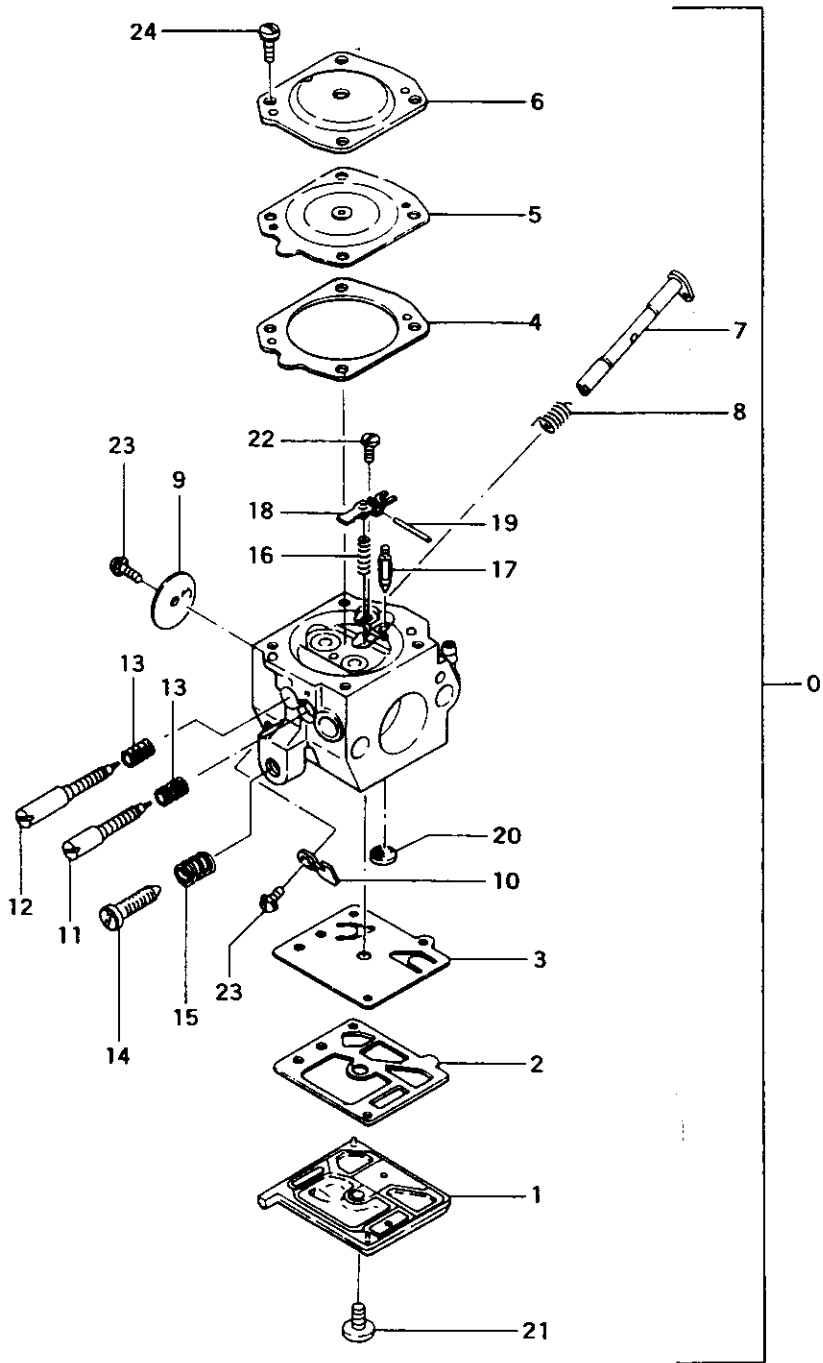

REF. NBR	PART NBR	PART NAME	QTY	SERIAL NBR	REMARKS
7-000	455-25014-901	CARBURETOR ASS'Y	1	R -D145328	
7-000	455-25012-902	CARBURETOR ASS'Y HDA-138	1	D145327-	
7-001	575-25012-200	PUMP BODY	1		
7-002	577-25012-200	PUMP GASKET	1		
7-003	576-25012-200	PUMP DIAPHRAGM	1		
7-004	475-25012-200	DIAPHRAGM GASKET	1		
7-005	474-25012-800	METERRING DIAPHRAGM COMP.	1		
7-006	476-25012-201	DIAPHRAGM COVER	1		
7-007	464-25012-800	THROTTLE SHAFT COMP.	1		
7-008	486-25012-200	THROTTLE SPRING	1		
7-009	488-25012-200	THROTTLE VALVE	1	M	
7-009	488-25001-200	THROTTLE VALVE	1		
7-010	559-25012-200	STOP PLATE	1		
7-011	460-25012-201	HIGH ADJUST SCREW	1	M	
7-011	460-25012-202	HIGH ADJUST SCREW	1	R -D145326	
7-011	460-25012-210	HIGH ADJUST SCREW	1	D145327-	
7-012	461-25012-201	LOW ADJUST SCREW	1	R -D145326	
7-012	461-25012-210	LOW ADJUST SCREW	1	D145327-	
7-013	623-25001-200	HIGH/LOW ADJUST SPRING	2		
7-014	462-25012-200	IDLE ADJUST SCREW	1	M	
7-014	462-25016-200	IDLE ADJUST SCREW	1		
7-015	463-25012-200	IDLE ADJUST SPRING	1		
7-016	477-25012-200	VALVE SPRING	1		
7-017	603-25012-200	NEEDLE VALVE	1		
7-018	473-25012-200	CONTROL LEVER	1		
7-019	605-25001-200	HINGE PIN	1		
7-020	578-25006-200	INLET SCREEN	1	M	
7-020	578-25007-200	INLET SCREEN	1		
7-021	514-25012-200	SET SCREW	1		
7-022	546-25001-200	HINGE PIN SET SCREW	1		
7-023	467-25003-200	SHUTTER SCREW	2		
7-024	990-11030-081	SCREW 3X8	4	M	
7-024	548-25014-200	SET SCREW	4	M	
7-024	548-25012-200	SET SCREW	4		

FIG.8 TOOLS

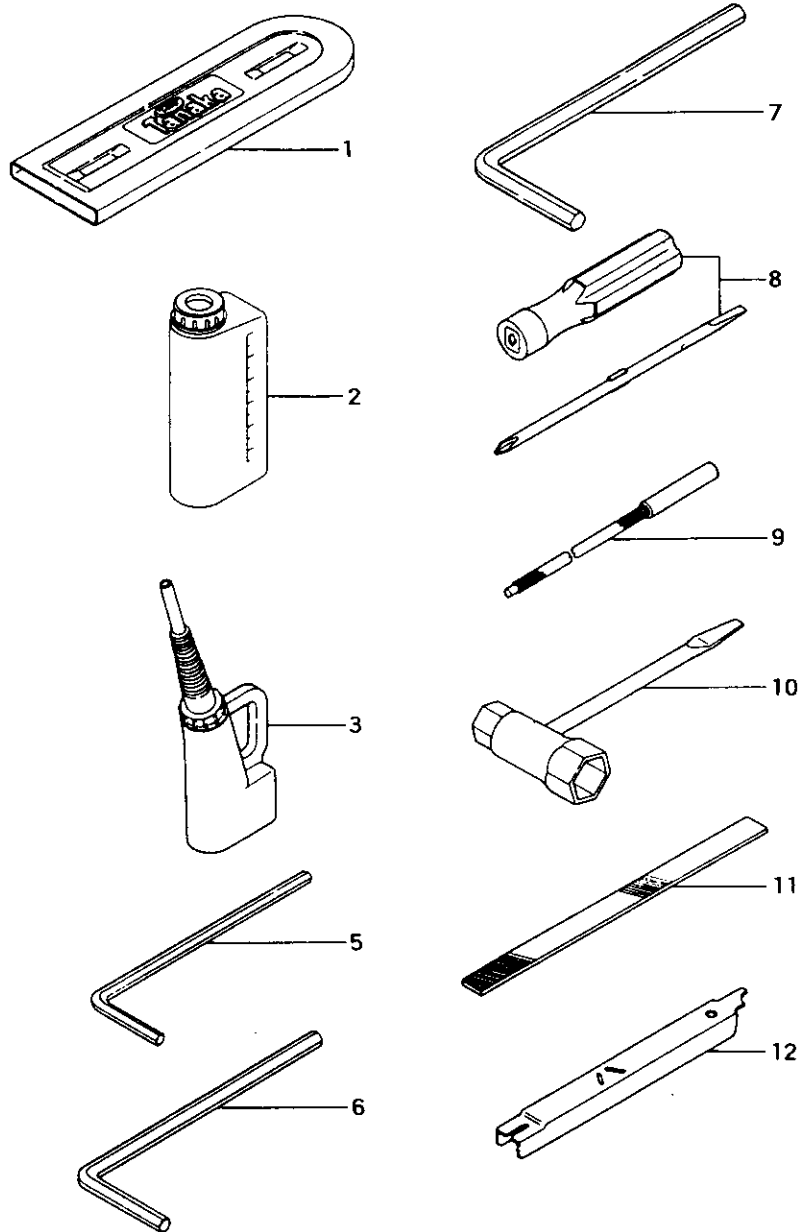

REF. NBR	PART NBR	PART NAME	QTY	SERIAL NBR	REMARKS
8-001	945-32605-200	CHAIN COVER 18"/20"/24"	1	I -C187436	
8-001	945-32605-201	CHAIN COVER 18"/20"/24"	1	C187437-	
8-002	872-20000-201	FUEL PREMIX CANISTER	1		
8-003	840-32600-900	OIL MIXING CANISTER	1		
8-005	812-20000-200	HEX. WRENCH 3	1		
8-006	813-20000-200	HEX. WRENCH 4	1		
8-007	815-20000-200	HEX. WRENCH 6	1		
8-008	901-32600-900	DRIVER ASS'Y	1		
8-009	892-32600-900	FILE ASS'Y 3/16"	1	-F102050	
8-009	892-32603-900	FILE 7/32" ASS'Y	1	N F102051-	
8-010	883-32600-200	COMBI. BOX SPANNER 13X19 MINUS	1		
8-011	895-32600-201	FLAT FILE 8"	1		
8-012	899-32600-200	DEPTH GAUGE	1		

FIG.9 MARKS

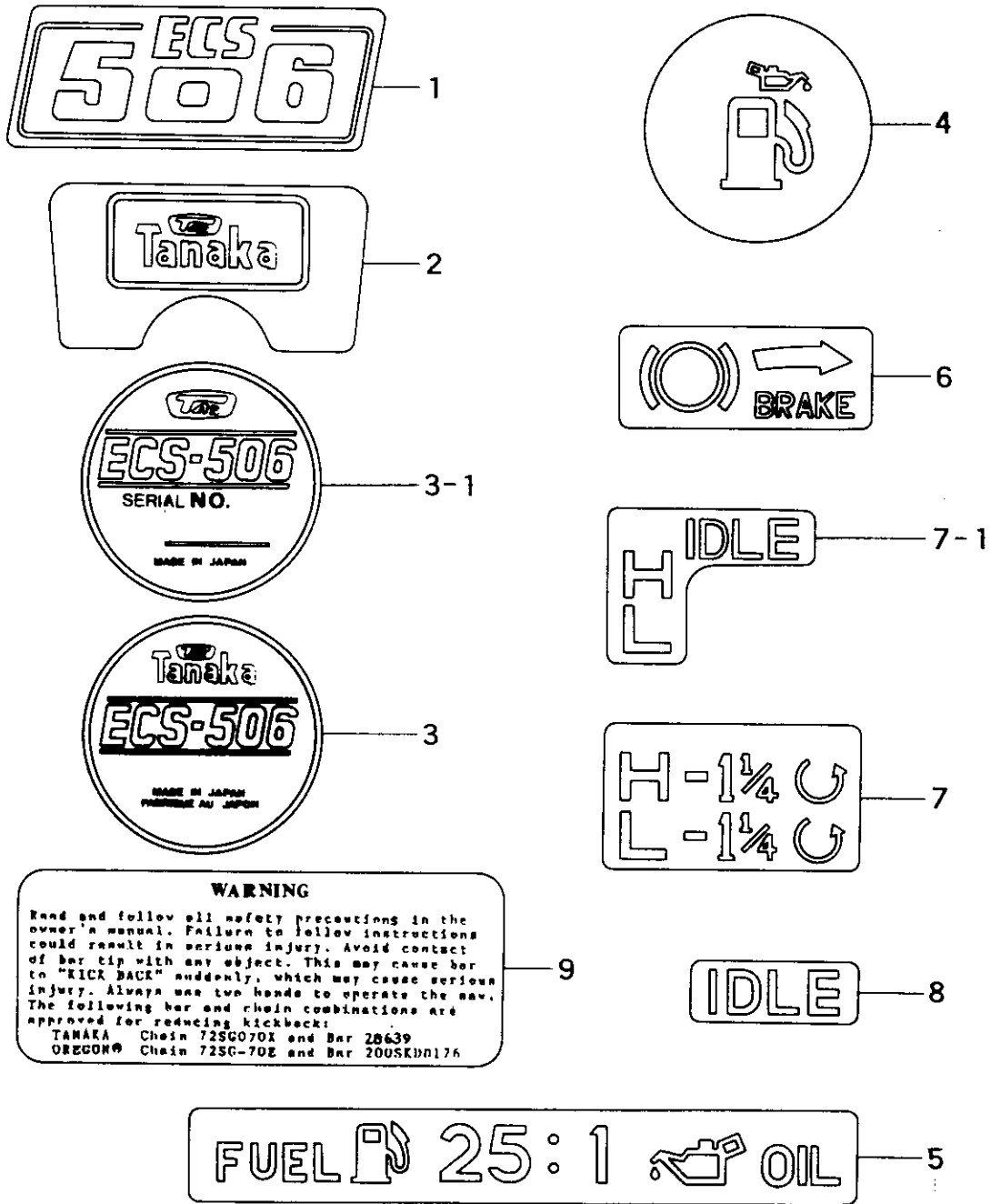

REF. NBR	PART NBR	PART NAME	QTY	SERIAL NBR	REMARKS
9-001	906-32600-210	NAME PLATE	1		
9-002	929-11650-200	SYMBOL MARK	1		
9-003, 1	915-32603-210	STARTER MARK	1	R -C154793	
9-003	915-32603-211	STARTER MARK	1	C154794-	
9-004	920-32650-201	FUEL MARK	1		
9-005	935-32600-200	TANK SIDE MARK A	1		
9-006	937-32600-200	TANK SIDE MARK C	1		
9-007, 1	910-32650-210	CARBURETOR CAUTION MARK	1	-C187436	
9-007	910-32601-200	CARB. INSTRUCTION MARK A	1	N C187437-	
9-008	911-32365-200	CARBURETOR CAUTION MARK B	1	N C187437-	
9-009	907-32603-200	CAUTION MARK FOR KICK BACK	1		

Free Manuals Download Website

<http://myh66.com>

<http://usermanuals.us>

<http://www.somanuals.com>

<http://www.4manuals.cc>

<http://www.manual-lib.com>

<http://www.404manual.com>

<http://www.luxmanual.com>

<http://aubethermostatmanual.com>

Golf course search by state

<http://golfingnear.com>

Email search by domain

<http://emailbydomain.com>

Auto manuals search

<http://auto.somanuals.com>

TV manuals search

<http://tv.somanuals.com>