

Tanaka

Parts Catalog

Hedgetrimmer

Model: THT-212

All Units Prior To Serial Number F030676

FIG.1 ENGINE

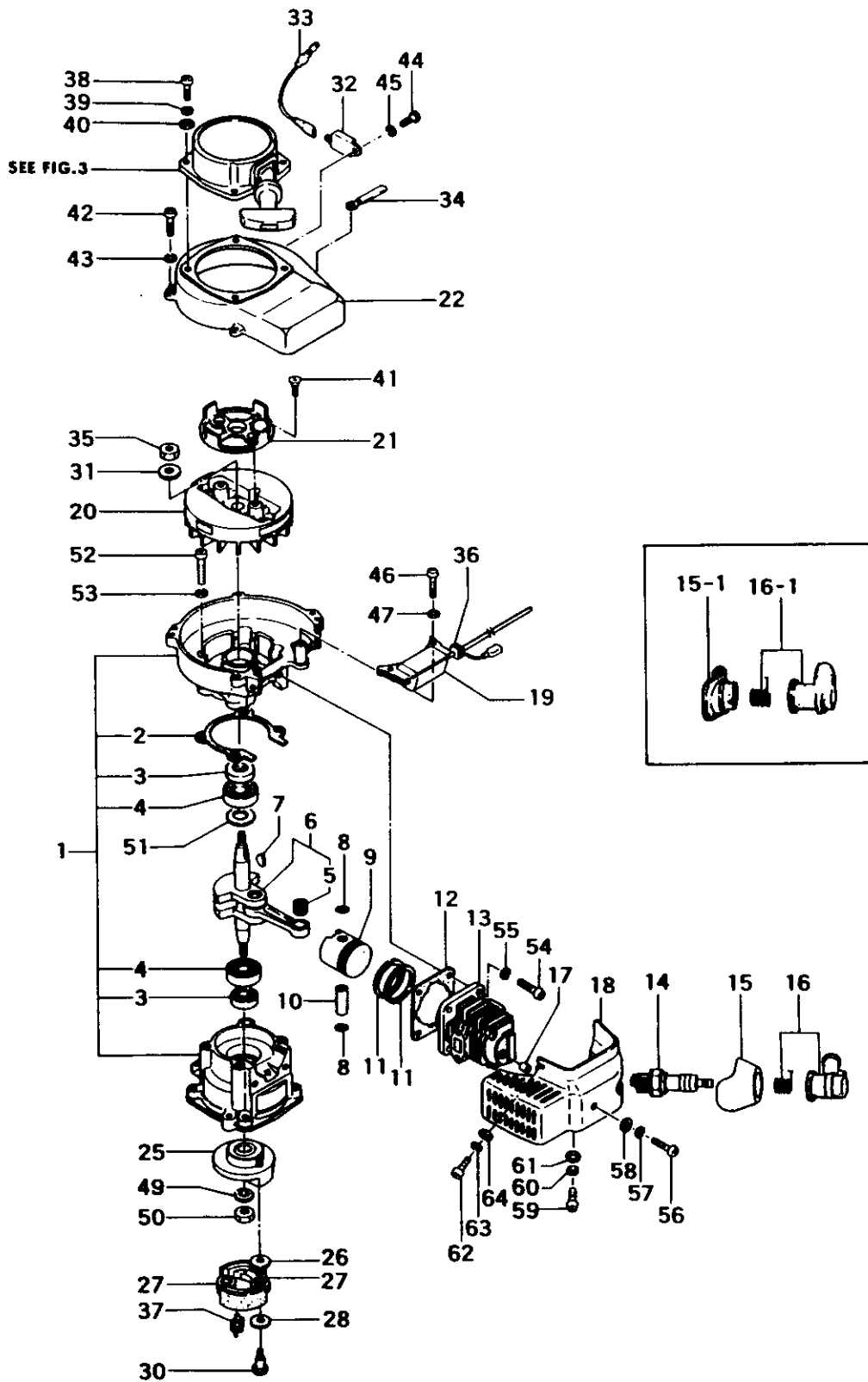

REF. NBR	PART NBR	PART NAME	QTY	SERIAL NBR	REMARKS
1-001	072-0639T-900	CRANK CASE ASS'Y	1		
1-002	090-08000-202	CRANK CASE GASKET	1		
1-003	999-66122-268	OIL SEAL 12227	2		
1-004	999-61600-100	BALL BEARING #6001, 28MM/OD	2		
1-005	999-62071-127	NEEDLE BEARING F-79	1		
1-006	046-0639W-801	CRANK SHAFT COMP.	1		
1-007	068-10100-200	WOOD-RUFF KEY 3X13X4.5	1		
1-008	039-06100-200	CIR CLIP	2		
1-009	031-06097-200	PISTON	1	R	-D154695
1-009	031-06097-201	PISTON	1		D154696-
1-010	037-06097-200	PISTON PIN	1		
1-011	041-00000-200	PISTON RING	2		
1-012	017-06091-200	CYLINDER GASKET	1	I	-E110591
1-012	017-06091-201	CYLINDER GASKET	1		E110592-
1-013	002-0632R-801	CYLINDER COMP.	1	R	-D074939
1-013	002-06092-803	CYLINDER COMP.	1		D074940-
1-014	018-00502-200	SPARK PLUG BM6A	1		
1-015, 1	255-0608A-200	SPARK PLUG RUBBER COVER	1		-E272075
1-015	255-0630G-210	SPARK PLUG RUBBER COVER	1	N	E272076-
1-016, 1	157-04000-900	SPARK PLUG CAP ASS'Y	1		-E272075
1-016	157-04200-900	SPARK PLUG CAP ASS'Y	1	N	E272076-
1-017	011-0630B-200	CYLINDER COVER COLLAR	1		
1-018	738-0632R-201	MUFFLER PROTECTOR	1		
1-019	167-20745-801	IGNITION COIL COMP.	1		
1-020	155-21718-800	MAGNETO ROTOR COMP.	1		
1-021	798-0639W-200	STARTER PULLEY	1		
1-022	112-0639W-200	FAN CASE	1		
1-025	347-0639W-800	CLUTCH FLANGE COMP.	1		
1-026	359-02103-200	CLUTCH WASHER B	2		
1-027	290-00501-802	CLUTCH SHOE COMP.	2		
1-028	358-02103-200	WASHER	2		
1-030	357-00601-200	STEP BOLT	2		
1-031	065-00000-200	FLYWHEEL WASHER	1		
1-032	159-21401-872	IGNITOR COMP. TTI-1F	1		
1-033	173-01620-800	IGNITOR LEAD WIRE COMP., R110M	1		
1-034	198-01046-900	CORD CLAMP ASS'Y	1		
1-035	327-00201-200	NUT 7 (L. H. THREAD)	1		
1-036	203-10000-200	PRIMARY CORD GROMMET	1		
1-037	342-00501-204	CLUTCH SPRING	1		
1-038	990-11040-121	SCREW 4X12	4		
1-039	992-10040-012	S. WASHER 4	4		
1-040	992-01040-011	WASHER 4	4		
1-041	990-12060-150	F.H. SCREW 6X15	2	M	
1-041	990-12060-151	F.H. SCREW 6X15	2		
1-042	990-11050-161	SCREW 5X16	4		
1-043	992-10050-012	S. WASHER 5	4		
1-044	990-11040-081	SCREW 4X8	1		
1-045	992-10040-012	S. WASHER 4	1		
1-046	990-11040-181	SCREW 4X18	2		
1-047	992-10040-012	S. WASHER 4	2		
1-049	992-10080-012	S. WASHER 8	1		
1-050	991-16080-003	NUT 8 (L.H. THREAD)	1		
1-051	330-00200-210	GEAR SHAFT SHIM 0.10	V		
1-051	330-00200-220	GEAR SHAFT SHIM 0.15	V		
1-051	330-00200-230	GEAR SHAFT SHIM 0.20	V		
1-051	330-00200-240	GEAR SHAFT SHIM 0.30	V		
1-052	990-11050-301	SCREW 5X30	4		
1-053	992-10050-012	S. WASHER 5	4		
1-054	990-11050-181	SCREW 5X18	4		
1-055	992-10050-012	S. WASHER 5	4		
1-056	990-11050-181	SCREW 5X18	1		
1-057	992-10050-012	S. WASHER 5	1		
1-058	992-01050-011	WASHER 5	1		

- To be cont'd -

REF. NBR	PART NBR	PART NAME	QTY	SERIAL NBR	REMARKS
1-059	990-11050-121	SCREW 5X12	1		
1-060	992-10050-012	S. WASHER 5	1		
1-061	992-01050-011	WASHER 5	1		
1-062	990-11040-121	SCREW 4X12	1		
1-063	992-10040-012	S. WASHER 4	1		
1-064	992-01040-011	WASHER 4	1		

FIG.2 ENGINE COMPONENTS

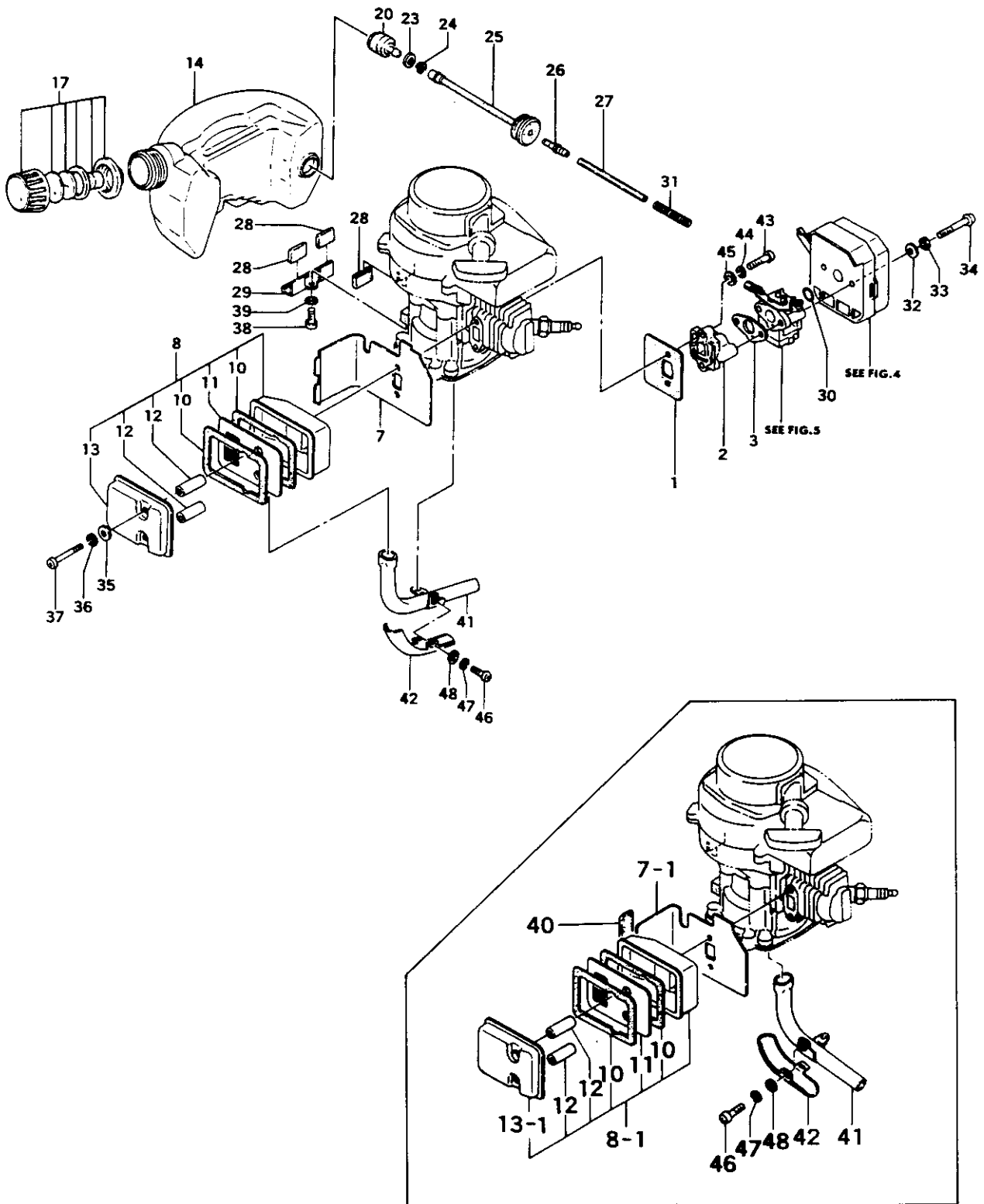

REF. NBR	PART NBR	PART NAME	QTY	SERIAL NBR	REMARKS
2-001	403-0602K-201	INLET MANIFOLD GASKET	1		
2-002	404-0639W-801	CARBURETOR INSULATOR COMP.	1		
2-003	402-0602K-200	CARBURETOR GASKET	1		
2-007	133-0602K-202	HEAT SHIELD	1	R -E110591	
2-007	133-0602K-203	HEAT SHIELD	1	R -E272075	
2-007	133-0602K-204	HEAT SHIELD	1	E272076-	
2-008	706-0602B-900	MUFFLER ASS'Y W/ARRESTER	1	R -D154695	
2-008	706-0639T-900	MUFFLER ASS'Y	1	D154696-	
2-010	739-0602B-200	MUFFLER COUPLING GASKET	2		
2-011	722-0602B-800	MUFFLER PARTITION PLATE COMP.	1		
2-012	740-0602B-201	MUFFLER COLLAR	2		
2-013	717-0602B-200	MUFFLER BODY B	1	R -D154695	
2-013	717-0639T-800	MUFFLER BODY B COMP.	1	D154696-	
2-014	591-0639W-201	TANK	1		
2-017	595-0062A-910	TANK CAP ASS'Y, ORANGE	1	M	
2-017	595-0062A-901	TANK CAP ASS'Y	1		
2-020	675-06020-900	PUMP FILTER BODY ASS'Y	1		
2-023	992-01050-011	WASHER 5	1		
2-024	680-04019-210	CLIP 7	1		
2-025	678-0602W-200	RUBBER PIPE	1		
2-026	497-32350-200	PIPE JOINT	1		
2-027	700-03005-110	FUEL PIPE 3X5X110	1		
2-028	655-06100-200	FUEL TANK CUSHION RUBBER	4		
2-029	653-06000-200	FUEL TANK BRACKET	1		
2-030	431-0602K-200	AIR CLEANER GASKET	1		
2-031	702-02004-200	FUEL PIPE COIL	1		
2-032	992-01050-011	WASHER 5	2		
2-033	992-10050-012	S.WASHER 5	2		
2-034	990-11050-701	SCREW 5X70	2		
2-035	992-01050-011	WASHER 5	2		
2-036	992-10050-012	S.WASHER 5	2		
2-037	990-11050-421	SCREW 5X42	2		
2-038	990-11050-141	SCREW 5X14	1		
2-039	992-10050-012	S.WASHER 5	1		
2-040	599-0602K-201	CUSHION RUBBER	1	M	
2-040	599-0602K-200	CUSHION RUBBER	1	D E110592-	
2-041	721-0639T-800	TAIL PIPE COMP.	1		
2-042	752-0639T-200	MUFFLER PROTECTOR B	1		
2-043	990-11050-221	SCREW 5X22	2		
2-044	992-10050-012	S.WASHER 5	2		
2-045	992-00050-011	SMALL WASHER 5	2		
2-046	990-11040-101	SCREW 4X10	1		
2-047	992-10040-012	S.WASHER 4	1		
2-048	992-01040-011	WASHER 4	1		

FIG.3 RECOIL STARTER

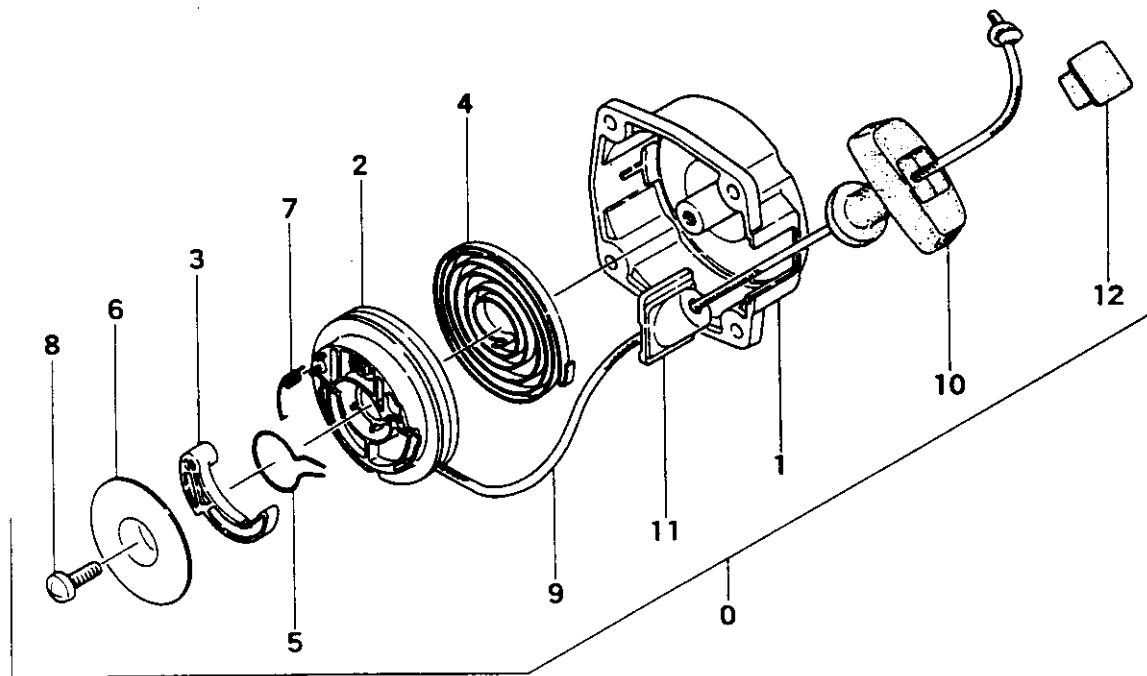

REF. NBR	PART NBR	PART NAME	QTY	SERIAL NBR	REMARKS
3-000	756-0639V-900	RECOIL STARTER ASS'Y	1		
3-000	782-06150-901	RECOIL STARTER BODY ASS'Y	1		
3-001	772-06150-200	RECOIL STARTER BODY	1		
3-002	789-01250-200	STARTER ROPE REEL	1		
3-003	788-01250-200	STARTER PAWL	1		
3-004	779-01250-200	RECOIL SPRING	1		
3-005	836-01250-200	FRICTION SPRING	1		
3-005	836-06092-200	FRICTION SPRING	1		
3-006	837-01250-200	FRICTION PLATE	1		
3-006	837-06092-200	FRICTION PLATE	1		
3-007	832-01250-200	RETURN SPRING	1		
3-008	990-15050-121	SCREW 5X12	1		
3-009	783-06150-200	ROPE 3.5X890L	1		
3-009	783-06092-200	ROPE 3.5X890L	1		
3-010	785-06150-200	STARTER HANDLE	1		
3-010	785-06097-200	STARTER HANDLE	1		
3-011	780-06150-200	ROPE GUIDE	1		
3-012	785-0602K-200	STARTER HANDLE CAP	1		

FIG.4 AIR CLEANER

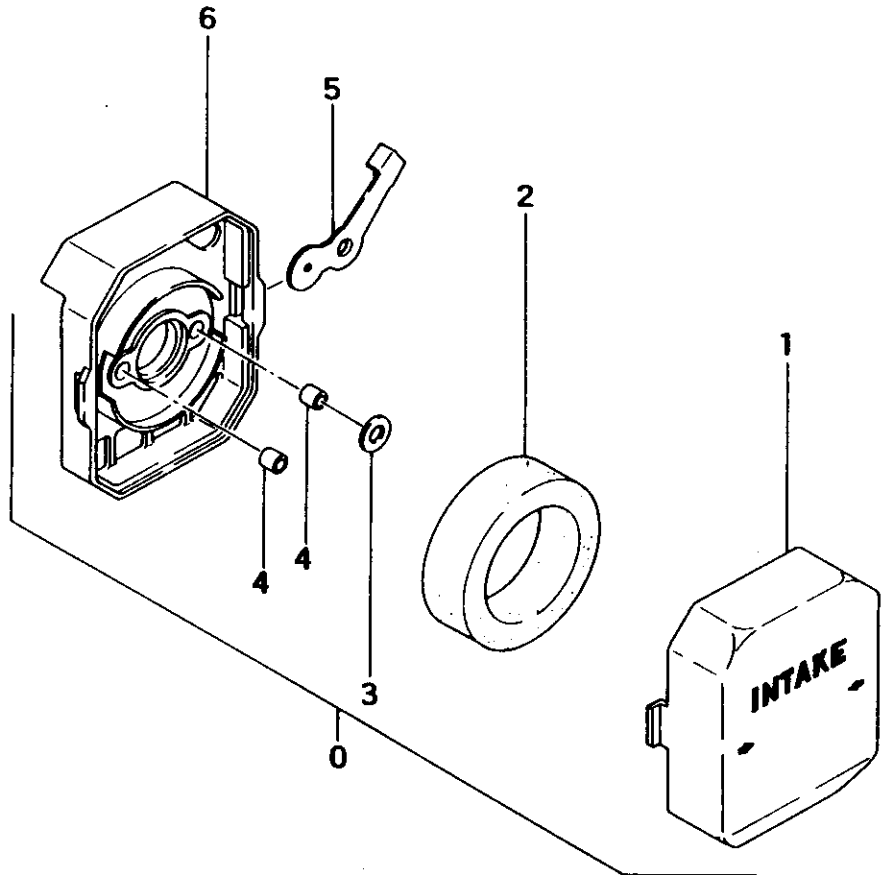

REF. NBR	PART NBR	PART NAME	QTY	SERIAL NBR	REMARKS
4-000	410-0602D-901	AIR CLEANER ASS'Y	1		
4-001	424-0602K-200	AIR CLEANER CAP	1	N	
4-001	424-0602K-201	AIR CLEANER CAP	1		
4-002	446-0602K-200	CLEANER ELEMENT	1		
4-003	453-0602K-200	SPACER	1		
4-004	470-0602K-200	COLLAR	2		
4-005	528-0602D-200	CHOKE PLATE, V/2MM HOLE	1		
4-006	423-0602K-200	CLEANER BODY	1	N	
4-006	423-0602K-210	CLEANER BODY	1		

FIG.5 CARBURETOR

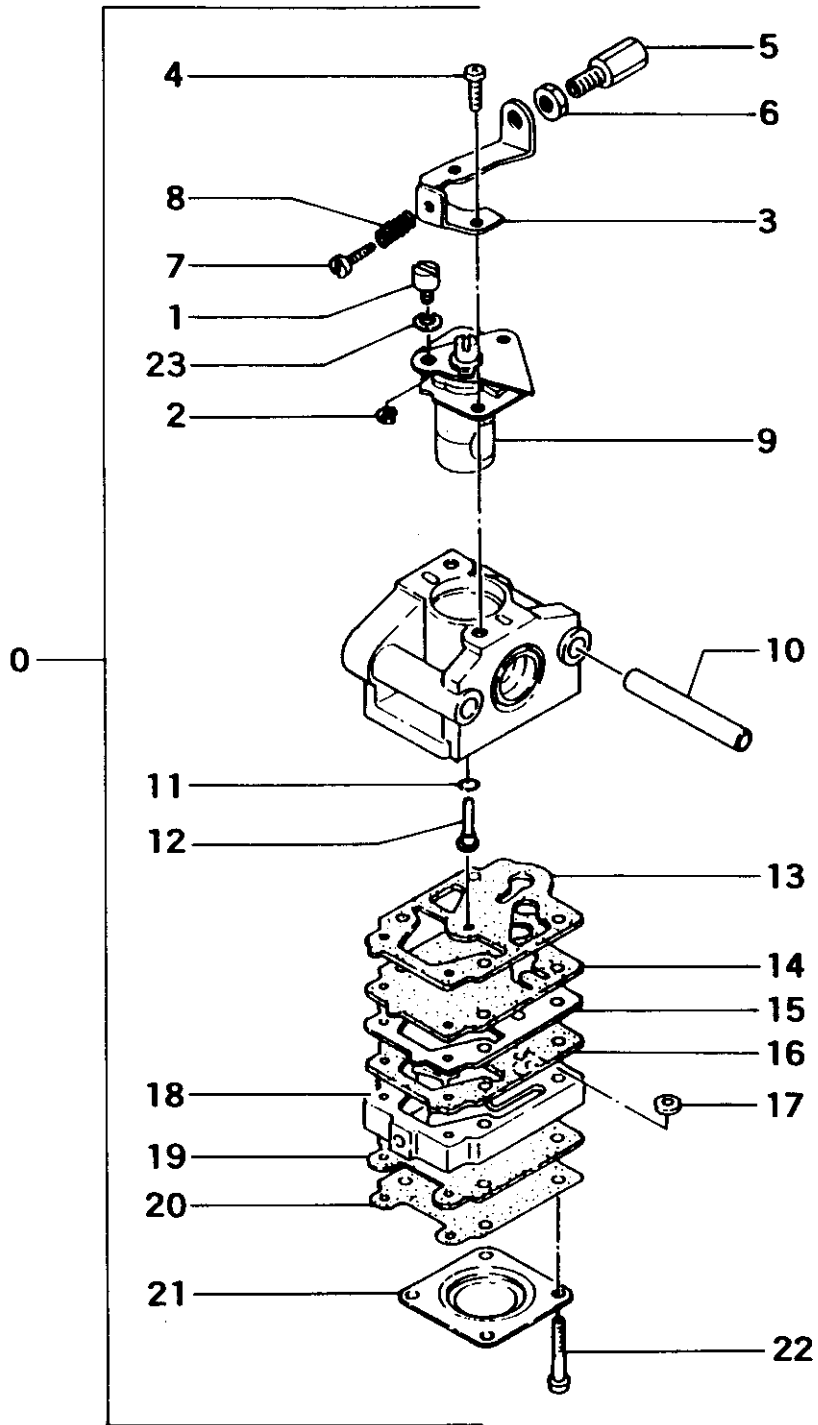

REF. NBR	PART NBR	PART NAME	QTY	SERIAL NBR	REMARKS
5-000	455-25102-900	CARBURETOR ASS'Y VY-8	1	R -D154695	
5-000	455-25102-901	CARBURETOR ASS'Y VY-8	1	D154696-	
5-001	539-25100-200	SWIVEL	1	M	
5-001	539-25101-200	SWIVEL	1		
5-002	489-25100-200	STOP RING	1		
5-003	544-25100-200	ADJUSTER STAY	1		
5-004	514-25100-200	THROTTLE SET SCREW	2		
5-005	614-25100-200	CABLE ADJUSTER	1		
5-006	613-25100-200	CABLE ADJUST NUT	1		
5-007	462-25100-200	IDLE ADJUST SCREW	1	P -D154695	
5-007	462-25100-201	IDLE ADJUST SCREW	1	D154696-	
5-008	463-25100-200	IDLE ADJUST SPRING	1		
5-009	488-25100-800	THROTTLE VALVE COMP.	1		
5-010	437-25100-200	SLEEVE	2		
5-011	550-25100-200	O-RING	1		
5-012	599-25100-200	MAIN JET	1	M	
5-012	599-25100-252	MAIN JET #52	1	M	
5-012	599-2000V-520	MAIN JET #52	1		
5-013	577-25100-200	PUMP GASKET	1		
5-014	576-25100-200	PUMP DIAPHRAGM	1		
5-015	523-25100-200	PUMP PLATE	1	R -D154695	
5-015	523-25100-201	PUMP PLATE	1	D154696-	
5-016	522-25100-200	CIRCUIT PLATE	1		
5-017	578-25001-200	INLET SCREEN	1		
5-018	575-25100-800	PUMP BODY COMP.	1		
5-019	475-25001-200	DIAPHRAGM GASKET	1		
5-020	474-25001-800	METERING DIAPHRAGM COMP.	1		
5-021	476-25006-200	DIAPHRAGM COVER	1	M	
5-021	476-25004-200	DIAPHRAGM COVER	1		
5-022	548-25100-200	SET SCREW	4	M	
5-022	548-25101-200	SET SCREW	4		
5-023	549-25100-200	THRUST WASHER	1	M D154696-	

FIG.6 GEAR CASE & CUTTER

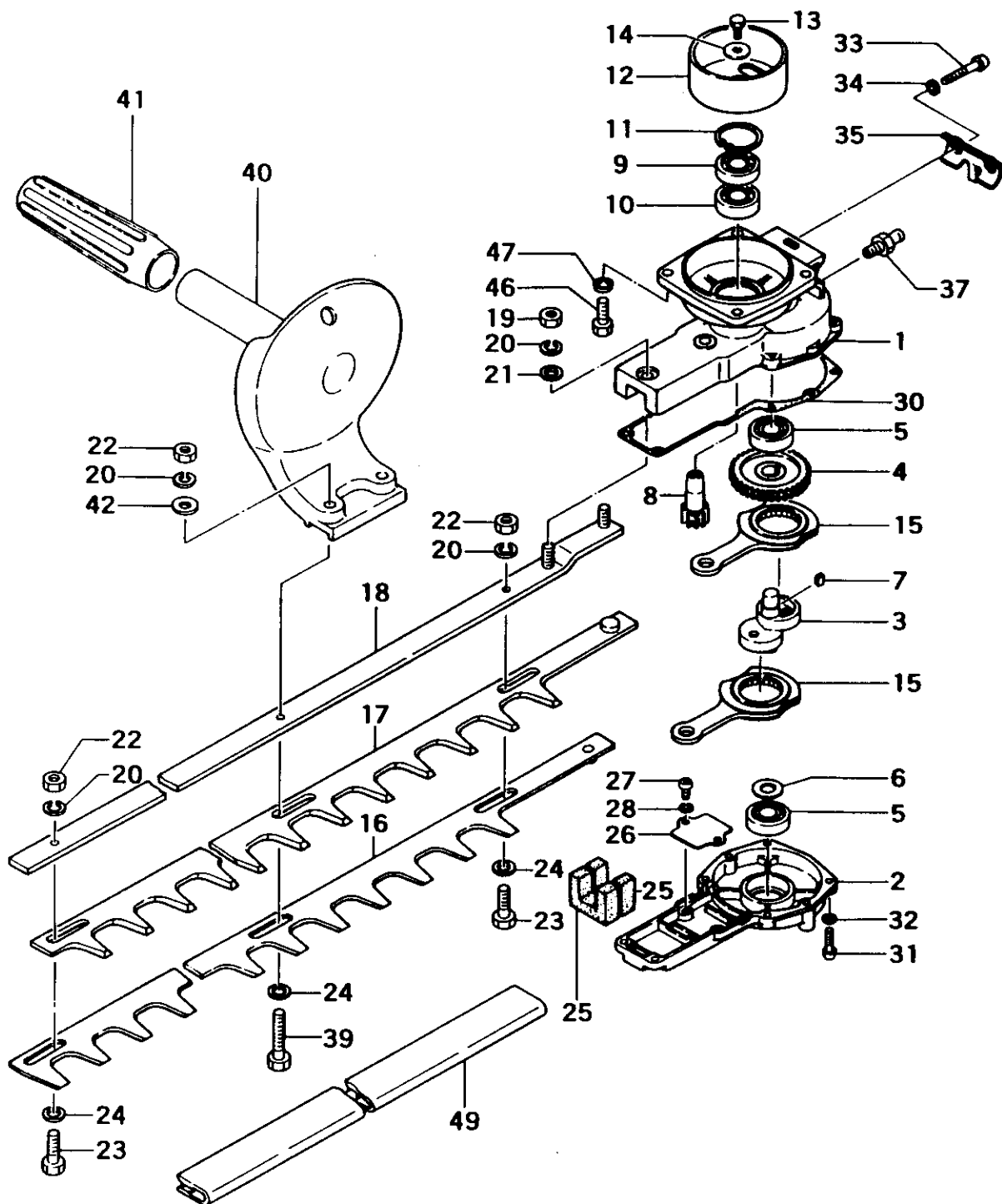

REF. NBR	PART NBR	PART NAME	QTY	SERIAL NBR	REMARKS
6-001	300-33230-210	GEAR CASE A	1		
6-002	301-33230-200	GEAR CASE B	1		
6-003	100-33210-203	CAM SHAFT	1		
6-004	307-33230-200	GEAR 2	1		
6-005	999-61829-000	BALL BEARING #629, 26MM/OD	2		
6-006	015-35100-200	SHAFT SHIM 0.1 (9.3X18)	V		
6-006	016-35100-201	SHAFT SHIM 0.2 (9.3X18)	V		
6-006	022-35100-200	SHAFT SHIM 0.3 (9.3X18)	V		
6-007	068-00300-200	WOOD-RUFF KEY 3X10X3.7	1		
6-008	306-33230-210	GEAR 1	1		
6-009	999-61600-003	BALL BEARING 6000D, 26MM/OD	1		
6-010	999-61600-000	BALL BEARING #6000, 26MM/OD	1		
6-011	993-51026-002	STOP RING C-26 IN	1		
6-012	288-0602W-821	CLUTCH DRUM COMP.	1		
6-013	990-21050-106	H.T. BOLT 5X10	1		
6-014	368-32350-200	BRAKE SHAFT WASHER	1		
6-015	101-33230-800	CAM ROD COMP.	2		
6-016	120-33230-200	CUTTER A, L-675	1		
6-017	121-33230-200	CUTTER B, L-675	1		
6-018	122-33230-200	CUTTER GUIDE	1		
6-019	991-01080-011	NUT 6	2		
6-020	992-10060-012	S.WASHER 6	6		
6-021	992-01080-011	WASHER 6	2		
6-022	123-33202-200	CUTTER FIXING NUT	4		
6-023	124-33202-206	CUTTER FIXING BOLT A	3		
6-024	129-33202-201	WASHER 7	4		
6-025	085-33230-200	GREASE SEAL A	2		
6-026	075-33230-200	CAM ROD GUIDE PLATE	1		
6-027	990-11040-081	SCREW 4X8	2		
6-028	992-10040-012	S.WASHER 4	2		
6-030	303-33230-200	GEAR CASE GASKET	1		
6-031	990-11040-161	SCREW 4X16	6		
6-032	992-10040-012	S.WASHER 4	6		
6-033	990-11050-271	SCREW 5X27	2		
6-034	992-10050-012	S.WASHER 5	2		
6-035	057-33230-200	HANDLE HOLDER	1		
6-037	200-33210-210	GREASE NIPPLE	1		
6-039	125-33202-205	CUTTER FIXING BOLT B	1		
6-040	051-33210-820	HANDLE B COMP.	1		
6-041	165-35100-202	HANDLE GRIP	1		
6-042	992-01080-011	WASHER 6	1		
6-046	990-23060-161	PLUS BOLT 6X16	4		
6-047	992-10060-012	S.WASHER 6	4		
6-049	138-33231-201	CUTTER COVER, L-620	1	R -D154695	
6-049	138-33231-202	CUTTER COVER, L-620	1	D154696-	

FIG.7 HANDLE

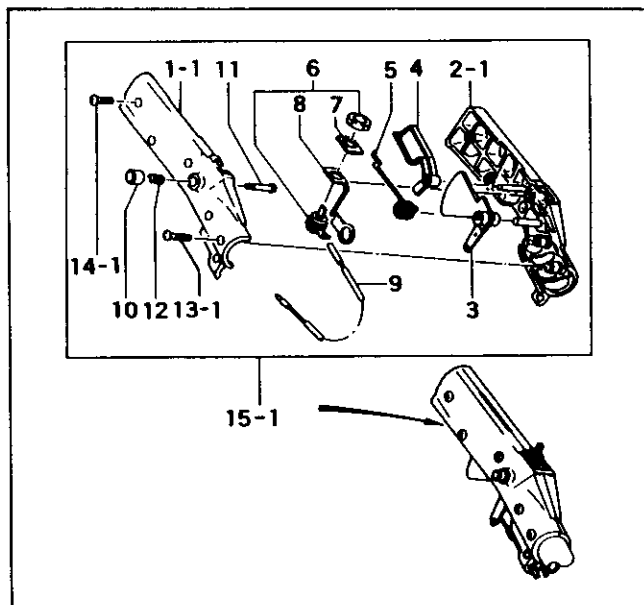
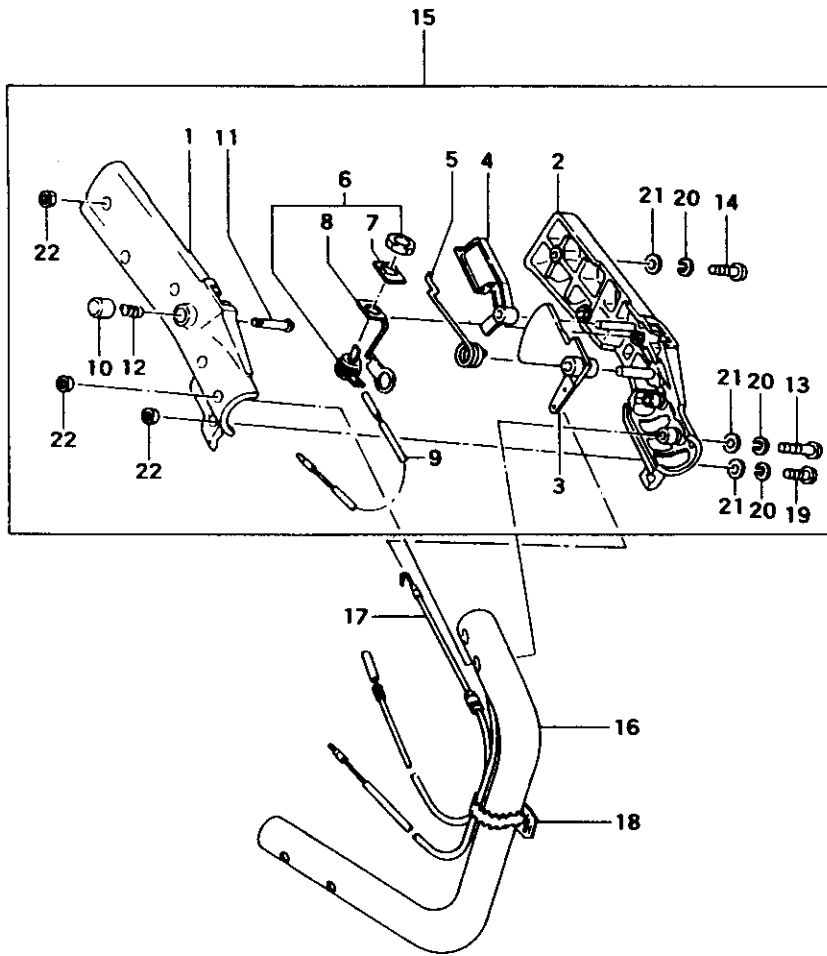

REF. NBR	PART NBR	PART NAME	QTY	SERIAL NBR	REMARKS
7-001,1	053-33231-201	HANDLE GRIP A	1	R -D154695	
7-001,1	053-33231-210	HANDLE GRIP A	1	-F030276	
7-001	053-33231-220	HANDLE GRIP A	1	N F030277-	
7-002,1	054-33231-201	HANDLE GRIP B	1	R -D154695	
7-002,1	054-33231-210	HANDLE GRIP B	1	-F030276	
7-002	054-33231-220	HANDLE GRIP B	1	N F030277-	
7-003	230-33210-200	THROTTLE LEVER	1	I -F030276	
7-003	230-33210-201	THROTTLE LEVER	1	F030277-	
7-004	231-33210-200	SAFETY LEVER	1		
7-005	061-32600-200	THROTTLE LEVER SPRING	1	I -F030276	
7-005	061-32600-201	THROTTLE LEVER SPRING	1	F030277-	
7-006	162-01300-900	STOP SWITCH ASS'Y	1		
7-007	183-01300-200	SWITCH NAME PLATE	1		
7-008	319-43225-200	EARTH TERMINAL	1		
7-009	178-33250-800	STOP CORD	1	-D154695	
7-009	178-33250-801	STOP CORD	1	N D154696-	
7-010	725-32600-202	PUSH PIN CAP	1		
7-011	064-32530-200	PUSH PIN	1		
7-012	066-32300-201	STOPPER SPRING	1		
7-013,1	993-41040-251	HI-LO SCREW 4X25	3	-F030276	
7-013	990-11040-301	SCREW 4X30	2	N F030277-	
7-014,1	993-41040-151	HI-LO SCREW 4X15	3	-F030276	
7-014	990-11040-251	SCREW 4X25	1	N F030277-	
7-015,1	055-33250-900	HANDLE GRIP ASS'Y	1	R -D154695	
7-015,1	055-33250-901	HANDLE GRIP ASS'Y	1	R -F030276	
7-015	055-33250-902	HANDLE GRIP ASS'Y	1	F030277-	
7-016	050-33250-200	HANDLE A	1		
7-017	885-0639T-800	THROTTLE WIRE COMP.	1		
7-018	903-32201-200	WIRE CLAMP BAND	1		
7-019	990-11040-141	SCREW 4X14	3	N F030277-	
7-020	992-10040-012	S. WASHER 4	6	N F030277-	
7-021	992-00040-011	SMALL WASHER 4	6	N F030277-	
7-022	991-74040-010	U-NUT 4	6	N F030277-	

FIG.8 TOOLS

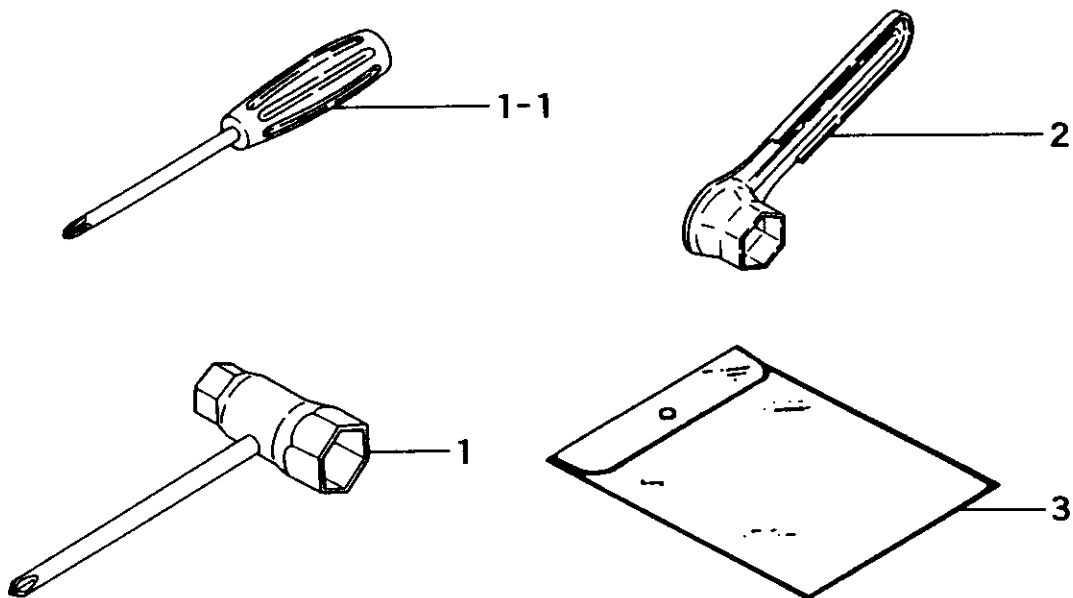

REF. NBR	PART NBR	PART NAME	QTY	SERIAL NBR	REMARKS
8-001,1	862-20000-200	PLUS DRIVER 4	1	-D154695	
8-001	036-29331-500	COMBI. BOX SPANNER 10X19 .PLUS	1	N D154696-	
8-001	036-29331-500	COMBI. BOX SPANNER 10X19 .PLUS	1	R -D221800	
8-001	036-29331-501	COMBI. BOX SPANNER 10X19 .PLUS	1	D221801-	
8-002	852-20000-200	SPARK PLUG BOX SPANNER	1	D D154696-	
8-003	948-32352-200	TOOL BAG	1		

FIG.9 MARKS



REF. NBR	PART NBR	PART NAME	QTY	SERIAL NBR	REMARKS
9-001	906-0639T-200	NAME PLATE	1		

Free Manuals Download Website

<http://myh66.com>

<http://usermanuals.us>

<http://www.somanuals.com>

<http://www.4manuals.cc>

<http://www.manual-lib.com>

<http://www.404manual.com>

<http://www.luxmanual.com>

<http://aubethermostatmanual.com>

Golf course search by state

<http://golfingnear.com>

Email search by domain

<http://emailbydomain.com>

Auto manuals search

<http://auto.somanuals.com>

TV manuals search

<http://tv.somanuals.com>