

arena
HIGHLINE 300



arena
HIGHLINE 300



| | | | |
|-----------------------|------------------------|------------------------|---------------------------|
| Tannoy United Kingdom | T: +44 (0) 1236 420199 | F: +44 (0) 1236 428230 | E: enquiries@tannoy.com |
| Tannoy North America | T: (519) 745 1158 | F: (519) 745 2364 | E: inquiries@tannoyna.com |
| Tannoy Deutschland | T: 0180 1111 88 1 | F: 0180 1111 88 2 | E: info@tannoy.com |

tannoy.com

6483 0981



“YOU ARE TRYING TO SEDUCE ME, AREN'T YOU?”
THE GRADUATE (1967)

Beauty is not just skin deep.

Arena HighLine is not just another home theatre speaker - it's a Tannoy - clearly not just another speaker company. Our loudspeaker engineering skills are legendary. Tannoy studio monitors, used throughout the professional recording world, have played a leading role in the audio production of many blockbuster movies.

Tannoy never cuts corners when it comes to loudspeaker design ...carefully and painstakingly rounded off ...but never cut. HighLine 300 is lavishly finished in silky smooth matt silver or black to beautifully enhance any contemporary surroundings.

The picture's amazing ...and that's even before the film starts!

Arena HighLine - a speaker design tempting enough to make you forget to switch the screen on.

Here's looking at you kid.

When it comes to setting up a home theatre, obviously a great picture is essential. But to achieve the full scale and impact of the movie experience, the soundtrack should get equal billing.

Tannoy HighLine completes the picture with the best sound ever.



“THIS IS OUR MOMENT TO SHINE, TO SHOW THEM WHAT WE'RE MADE OF.”

ROBOTS (2005)

A multi driver array comprising two 75mm (3") midrange units, two 75mm (3") bass units and one 19mm (0.75") ultra high frequency SuperTweeter™ is used in the elegantly slim and compact HighLine 300 series.

Using exactly the same driver complement in each of the loudspeakers within the full system ensures a synergy of sound which is a crucial element for the very best home theatre experience.

Extending the bandwidth of the loudspeakers by using a SuperTweeter ensures enhanced intelligibility by providing a more focussed sound stage through superior spatial imaging. Vocals and instruments are clearly more separate and distinct and percussive sounds have more reality and impact.

Mounting the high frequency unit centrally between two midrange drivers creates a larger radiating area and controls tweeter dispersion off axis. Technically known as a D'Appolito driver configuration, this system provides a greater uniform coverage area of the sound. This means that the whole family gets an equal share of the full home theatre experience and not just the person sat in the middle of the sofa!

For maximum acoustic integrity of the drive units the already robust cabinet is further internally braced at strategic points throughout its length to ensure perfect reproduction. So even if the postman rings twice ...you'll hear exactly what you're meant to.

Weight ...there's something else... In order to provide stability to the tall and slender cabinet the floor standing versions are provided with a substantially weighted platform. Offering the speakers a firm footing by lowering the centre of gravity provides additional acoustic benefits through enhanced floor coupling and subsequent stabilising of the audio image.



1. Extra thick walled enclosure extrusion
2. 19mm (0.75") SuperTweeter™
3. One of two 75mm (3") midrange drivers in D'Appolito configuration
4. Tannoy DMT™ (Differential Material Technology) cabinet bracing
5. Drive unit shielding

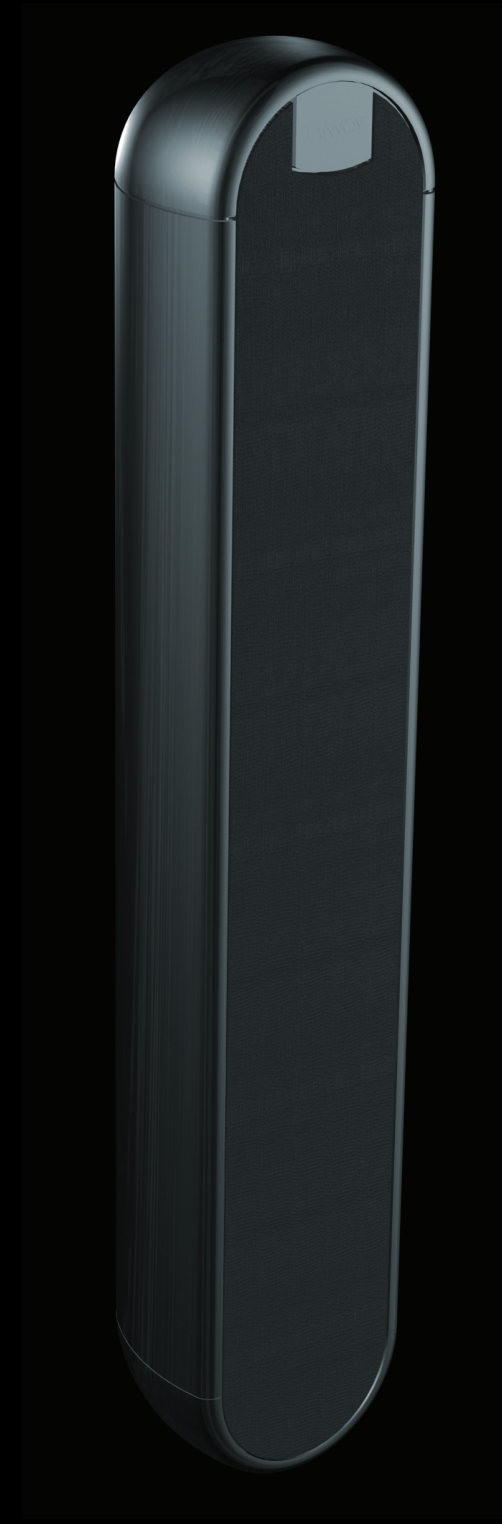



“WAIT A MINUTE, WAIT A MINUTE.
YOU AIN’T

Everything is worked out perfectly.

Exquisite engineering, attention to detail and robust construction are the hallmarks of all components and accessories throughout the HighLine range.

Not satisfied with specifying extravagantly thick section aluminium for the loudspeaker casing, Tannoy’s product design and acoustic engineering team have gone that extra mile to ensure that Arena HighLine is the absolute best in its class.

HEARD NOTHIN’ YET!”

THE JAZZ SINGER (1927)

In creating something so finely crafted the functionality element has not been ignored. Fitting effortlessly into the room environment is paramount so the simple, yet effective fixing mechanisms allow completely unobtrusive installation. Invisible wall mount brackets are standard, but low profile table stands and height adjustable floor stands, all with carefully thought through cable management, are available as optional accessories to ensure the speakers fit your décor seamlessly.

This combination of meticulously crafted design, exceptional acoustic performance and application flexibility has delivered a system that defines the category.



“I THINK THIS IS THE BEGINNING OF A BEAUTIFUL FRIENDSHIP.”

CASABLANCA (1942)

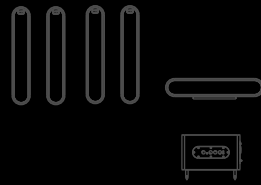

INCLUDING OPTIONAL FLOOR STANDS ON REAR SPEAKERS

“THAT PRETTY MUCH COVERS ALL THE OPTIONS, DON'T IT?”

FIREFLY (2002)

The versatility of Arena HighLine is exemplified by the breadth of choice of system options open to you. You may wish to opt for one of the two recommended speaker configurations, but the system has been designed to precisely adapt to your installation needs.

Offering absolute flexibility when it comes to integrating with your living space, Arena HighLine's versatile mounting platforms maximise performance and enable an exceptional variety of room integration solutions.

Use of the supplied wall brackets ensures a low profile, wall-hugging fixing of the satellites and centre. Height adjustable floor-mounting stands and custom table supports for use with the satellites are available as optional accessories.

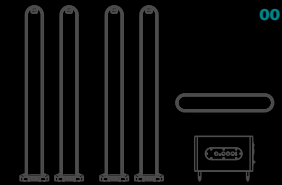
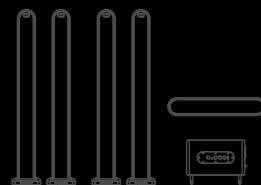

001

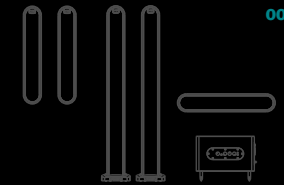

002

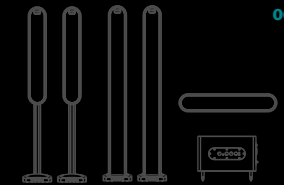

003

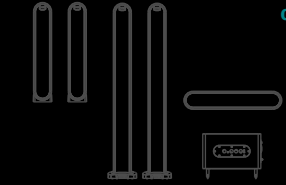

004

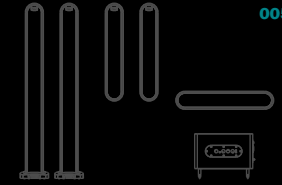

005

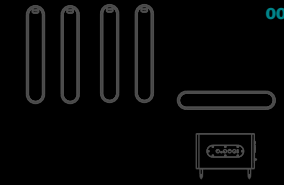

006

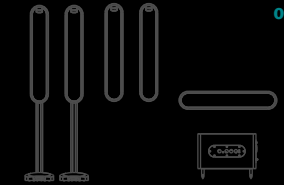

007

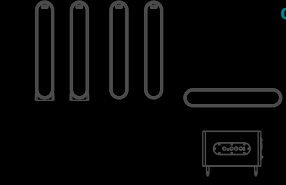

008

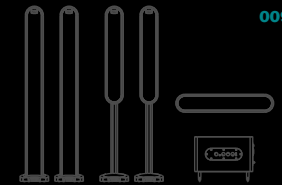

009

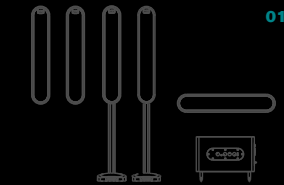

010

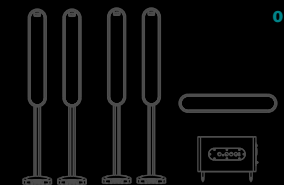

011

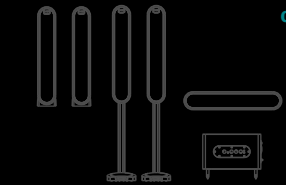

012

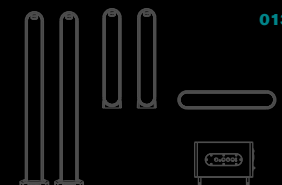

013

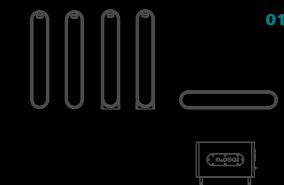

014

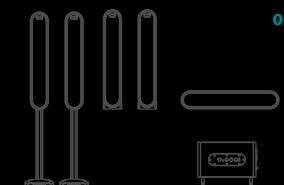

015

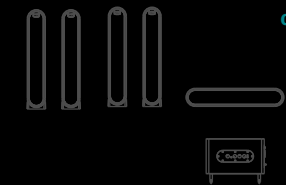

016

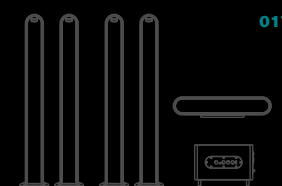

017

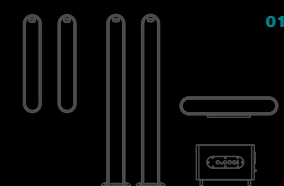

018

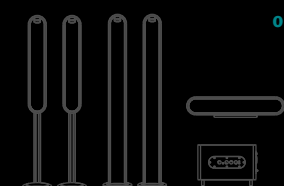

019

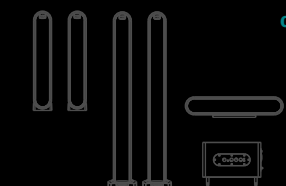

020

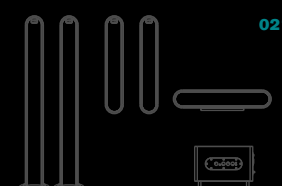

021

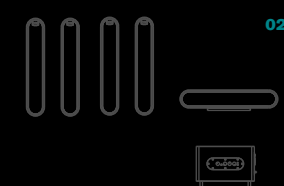

022

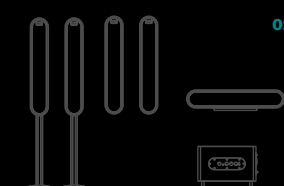

023

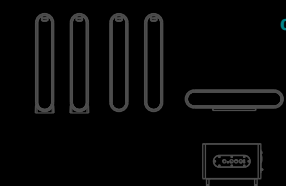

024

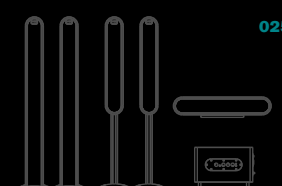

025

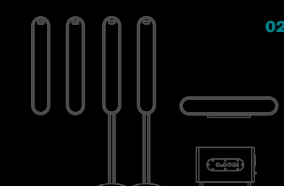

026

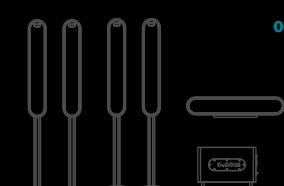

027

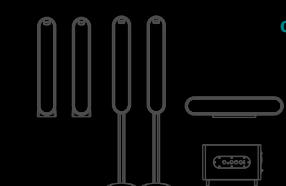

028

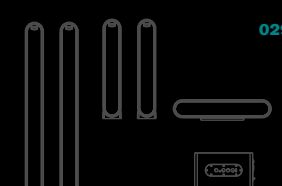

029

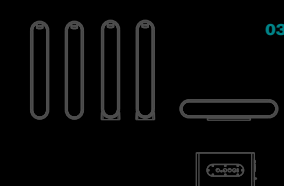

030

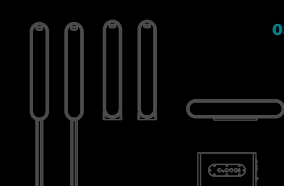

031

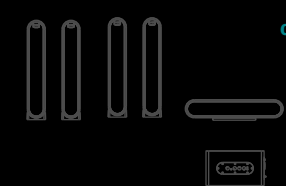

032

Shaken, not stirred.

The high efficiency 300 Watt power amplifier delivers exceptional performance and bandwidth to deliver the huge dynamics demanded by modern movie soundtracks.

It's possible when you hear mention of a subwoofer, you immediately think of a boring black box that you want to hide from view. Not so the Arena Highline subwoofer - it's beautifully finished to coordinate with the rest of the system.



“TELL ME ABOUT IT ...

The comprehensive control functions of the Arena Highline subwoofer enables simple optimisation of the unit for music or home cinema listening and output adjustment to match the relative level of the main speakers, or just setting to personal taste. Depending on available space or the desired visual effect, the subwoofer provides clever orientation options - the 280mm (10") driver can be faced downwards, sideways or forwards to optimise acoustic coupling to the listening room.



STUD”

GREASE (1978)

TECHNICAL DIAGRAMS

ARENA HIGHLINE 300

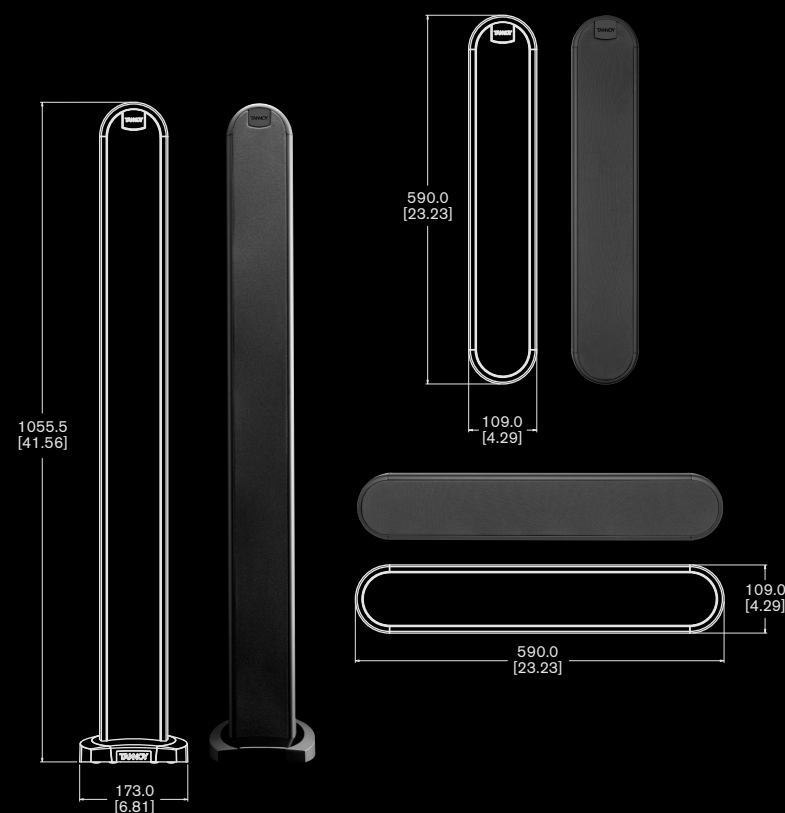

OPTIONAL ACCESSORIES

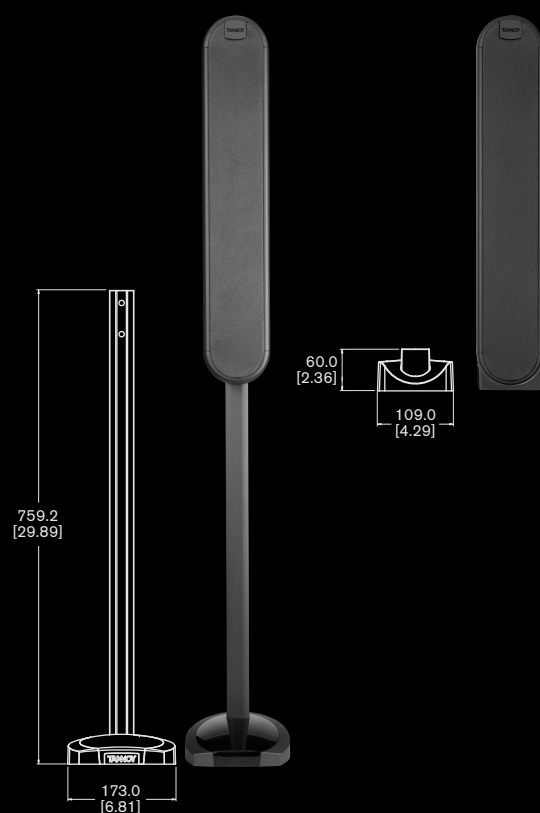

TS300 SUBWOOFER

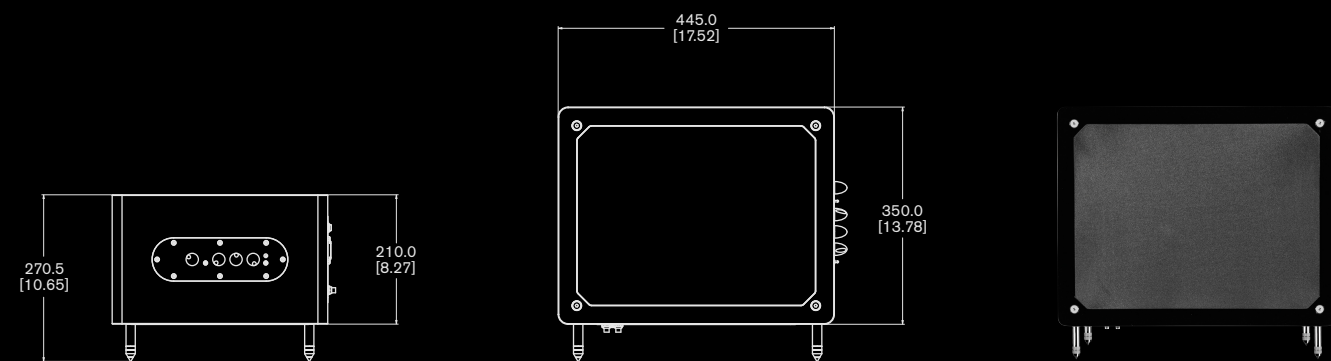

COLOUR OPTIONS

BLACK



SILVER

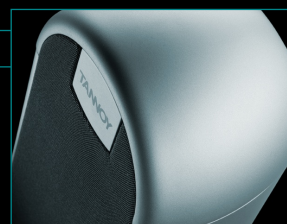

THE SILKY SMOOTH MATT SILVER OR BLACK FINISH OF HIGHLINE 300 WILL SEAMLESSLY BLEND WITH CONTEMPORARY SURROUNDINGS.

TECHNICAL SPECIFICATIONS

ARENA HIGHLINE 300 CENTRE & SATELLITE SPEAKER

PERFORMANCE

| | |
|-----------------------------------|---------------|
| RECOMMENDED AMPLIFIER POWER: | 25 - 75W RMS |
| MAXIMUM SENSITIVITY (2.83V @ 1m): | 87dB |
| NOMINAL IMPEDANCE: | 8 Ohm |
| FREQUENCY RESPONSE (-6dB): | 95Hz - 62kHz |
| CROSSOVER FREQUENCY: | 300Hz, 6.0kHz |

DRIVE UNITS

| | |
|---------------------|--|
| DRIVER TYPE: | 4 x 75mm (3") LF/MF, 1 x 19mm (0.75") HF |
| MAGNETIC SHIELDING: | YES |

CONSTRUCTION

| | |
|-----------------------------------|--|
| SATELLITE WEIGHT: | 5 kg (11.1 lbs) |
| SATELLITE DIMENSIONS (H x W x D): | 590 x 109 x 101mm (23.23 x 4.29 x 3.98") |
| CENTRE WEIGHT: | 5 kg (11.1 lbs) |
| CENTRE DIMENSIONS: (H x W x D) | 109 x 590 x 101mm (4.29 x 23.23 x 3.98") |
| FINISH: | MATT BLACK, MATT SILVER |

ACCESSORIES

| | |
|-----------|--|
| SUPPLIED: | ALUMINIUM WALL BRACKET FOR EACH SATELLITE AND THE CENTRE CENTRE CHANNEL TABLE STAND |
| OPTIONAL: | FLOOR STAND FOR SATELLITES TABLE STAND FOR SATELLITES |

ARENA HIGHLINE 300 TOWER SPEAKER

PERFORMANCE

| | |
|-----------------------------------|---------------|
| RECOMMENDED AMPLIFIER POWER: | 25 - 75W RMS |
| MAXIMUM SENSITIVITY (2.83V @ 1M): | 87dB |
| NOMINAL IMPEDANCE: | 8 Ohms |
| FREQUENCY RESPONSE (-6DB): | 80Hz- 62kHz |
| CROSSOVER FREQUENCY: | 300Hz, 6.0kHz |

DRIVE UNITS

| | |
|---------------------|--|
| DRIVERS: | 4 x 75mm (3") LF/MF, 1 x 19mm (0.75") HF |
| MAGNETIC SHIELDING: | YES |

CONSTRUCTION

| | |
|-------------------------|---|
| WEIGHT: | 10 kg (22.3 lbs) |
| DIMENSIONS (H X W X D): | 1055 x 173 x 175mm (41.53 x 6.81 x 6.89") |
| FINISH: | MATT BLACK, MATT SILVER |
| SUPPLIED ACCESSORIES: | FLOOR COUPLING SPIKES AND POLISHED FLOOR PROTECTORS |

ARENA HIGHLINE TS300 SUBWOOFER TECHNICAL SPECIFICATIONS

PERFORMANCE

| | |
|--------------------------------|---|
| OUTPUT POWER: | 300W RMS |
| LOW FREQUENCY RESPONSE (-6DB): | 29Hz |
| LIMIT FOR USABLE OUTPUT: | 16Hz |
| INPUT: | 2 x LINE LEVEL PHONO (RCA) |
| INPUT FILTER (-6DB): | 2ND ORDER LOW PASS, 50Hz - 150Hz |
| AUTO MUTE: | AFTER APPROXIMATELY 12 MINUTES ABSENCE OF INPUT SIGNAL |
| ADDITIONAL FEATURES: | PHASE CONTROL, CROSSOVER DEFEAT SWITCH FOR LFE OPERATION, SOFT LIMITING TO AVOID OVERLOAD, LF EXTENSION CONTROL |

| | |
|----------------------------|---|
| MAINS VOLTAGE: | 120V NOMINAL AC ~ 60Hz, 230V NOMINAL AC ~50Hz |
| MAINS FUSE: | 120V - T3.15AL/ 250V, 230V - T1.6AL/ 250V |
| MAXIMUM POWER CONSUMPTION: | 416VA |

DRIVE UNIT

| | |
|--------------|-----------------|
| DRIVER TYPE: | 1 x 250mm (10") |
|--------------|-----------------|

CONSTRUCTION

| | |
|--|---|
| ENCLOSURE TYPE: | CLOSED BOX |
| ENCLOSURE VOLUME: | 20.0 LITRE (0.7 cu.ft.) |
| ENCLOSURE DIMENSIONS (EXCLUDING FEET): | 445 x 350 x 210mm (17.51 x 13.78 x 8.26") |
| ENCLOSURE WEIGHT: | 13kg (28.7lbs) |
| FINISH: | GLOSS BLACK, GLOSS SILVER |

Free Manuals Download Website

<http://myh66.com>

<http://usermanuals.us>

<http://www.somanuals.com>

<http://www.4manuals.cc>

<http://www.manual-lib.com>

<http://www.404manual.com>

<http://www.luxmanual.com>

<http://aubethermostatmanual.com>

Golf course search by state

<http://golfingnear.com>

Email search by domain

<http://emailbydomain.com>

Auto manuals search

<http://auto.somanuals.com>

TV manuals search

<http://tv.somanuals.com>