



Series 69

TWO-WAY SOUND REINFORCEMENT LOUDSPEAKERS & SUBWOOFER

6912

6915

6925

6918s

owner's manual

TAPCO[®]

www.tapcoworld.com

SAFETY INSTRUCTIONS

1. Read these instructions.
2. Keep these instructions.
3. Heed all warnings.
4. Follow all instructions.
5. Do not use this apparatus near water.
6. Clean only with a dry cloth.
7. Do not block any ventilation openings. Install in accordance with the manufacturer's instructions.
8. Only use attachments/accessories specified by the manufacturer.
9. Use only with a cart, stand, tripod, bracket, or table specified by the manufacturer, or sold with the apparatus. When a cart is used, use caution when moving the cart/apparatus combination to avoid injury from tip-over.
10. Damage Requiring Service — This product should be serviced only by qualified service personnel when:
 - A. Objects have fallen, or liquid has spilled into this product; or
 - B. This product has been exposed to rain; or
 - C. This product does not appear to operate normally or exhibits a marked change in performance; or
 - D. This product has been dropped, or its chassis damaged.
11. Servicing — The user should not attempt to service this product beyond those means described in this operating manual. All other servicing should be referred to an authorized Tapco Service Center.



12. Exposure to extremely high noise levels may cause permanent hearing loss. Individuals vary considerably in susceptibility to noise-induced hearing loss, but nearly everyone will lose some hearing if exposed to sufficiently intense noise for a period of time. The U.S. Government's Occupational

Safety and Health Administration (OSHA) has specified the permissible noise level exposures shown in the following chart.

According to OSHA, any exposure in excess of these permissible limits could result in some hearing loss. To ensure against potentially dangerous exposure to high sound pressure levels, it is recommended that all persons exposed to equipment capable of producing high sound pressure levels use hearing protectors while the equipment is in operation. Ear plugs or protectors in the ear canals or over the ears must be worn when operating the equipment in order to prevent permanent hearing loss if exposure is in excess of the limits set forth here.

Duration Per Day In Hours	Sound Level dBA, Slow Response	Typical Example
8	90	Packed garage concert
6	92	
4	95	VW Bus Peace Train
3	97	
2	100	Cranked psychedelic tunes
1.5	102	
1	105	High speed chase on C.H.I.P.s
0.5	110	
0.25 or less	115	Loudest parts at a Heavy Metal concert

Contents

SAFETY INSTRUCTIONS	2
Introduction	3
Getting Started	4
Hookup Diagrams	5
Placement	7
Room Acoustics	7
Protection	8
HF Protection	8
Amplifier Power	8
Appendix A: Service Information	10
Warranty Service	10
Troubleshooting	10
Repair	10
Appendix B: Connections	11
Appendix C: Specifications	12
TAPCO LIMITED WARRANTY	15

Don't forget to visit our website at www.tapcogear.com for more information about this and other TAPCO products.

What me, read a manual?

Before you begin, please make sure you read the Safety Instructions on page 2 and Getting Started on page 4.

Your new TAPCO® Series 69 loudspeakers are designed to set up quickly and operate easily. We know it's often seen as a sign of weakness to read a manual, along with asking for directions when lost, but we hope you will read the rest of the manual, at least while nobody is looking.

It is important to keep your receipt in a safe place, and not a bad idea to write your product information here for future reference (i.e., insurance claims, tech support, return authorization, etc.).

Product Serial #:

Speaker 1

Speaker 2

Purchased at:

Date of purchase:

Introduction

Thank you for choosing TAPCO Series 69 sound reinforcement loudspeakers. The TAPCO product line hails back to the days of TAPCO Corporation, Greg Mackie's first company. TAPCO revolutionized the audio industry back in 1969 with the very first 6-channel mixer specifically designed for keyboards and rock 'n' roll.

In essence, TAPCO redefined the price/performance ratio and made high-quality professional audio equipment accessible to virtually anyone. Today, TAPCO is reborn with the same ideals and is backed by the world-class engineering and manufacturing horsepower of LOUD Technologies. The Series 69 were designed by the same experts responsible for Mackie's best-selling SRM450 active loudspeakers and tweaked by the expert loudspeaker engineers at EAW.

The TAPCO Series 69 loudspeakers feature precision low-frequency woofers and 1-inch high-output compression drivers (except for the subwoofer) with built-in protection circuitry.

These versatile loudspeakers can be used in a variety of applications, including live sound reinforcement and music playback.

Here's a quick look at the TAPCO Series 69 features:

6912

- Mackie-designed 2-way full-range loudspeaker
- 1" HF compression driver
- 12" high-precision LF driver, vented
- Built-in HF driver protection circuitry
- 250 watts continuous power handling
- 8 ohm impedance
- Speakon™ and 1/4" inputs
- Rugged vinyl covering
- Protective corner bumpers
- Pole mount socket on bottom of enclosure

6915

- Mackie-designed 2-way full-range loudspeaker
- 1" HF titanium dome compression driver
- 15" high-precision LF driver, vented
- Built-in HF driver protection circuitry
- 300 watts continuous power handling
- 8 ohm impedance
- Speakon™ and 1/4" inputs
- Rugged vinyl covering
- Protective corner bumpers
- Pole mount socket on bottom of enclosure

Part No. 0011359 Rev. B 9/06

©2006 LOUD Technologies Inc. All Rights Reserved.

6925

- Mackie-designed 2-way full-range loudspeaker
- 1" HF compression driver
- Dual 15" high-precision LF drivers, vented
- Built-in HF driver protection circuitry
- 600 watts continuous power handling
- 8 ohm impedance
- Speakon™ and 1/4" inputs
- Rugged composite vinyl covering
- Protective corner bumpers

6918s

- 18" subwoofer
- 450 watts continuous power handling
- 8 ohm impedance
- Speakon™ and 1/4" inputs
- Durable painted enclosure
- Pole mount socket on top of enclosure

Getting Started



The following steps will help you set up your loudspeakers quickly.

- 1.** Make all initial connections with the power switches OFF on all equipment. Make sure the master volume, level, or gain controls are all the way down.
- 2.** Connect the line-level outputs from your mixing console (or other signal source) to the inputs of your power amplifier.
- 3.** Connect the "Speaker Output" from your power amplifier (or powered mixer) to the INPUT connector on the Series 69 (1/4" or Speakon jack).
- 4.** If you are using the 6918s subwoofer with one of the full-range loudspeakers, connect the 1/4" OUT or the Speakon LINK EXTENSION to the subwoofer's input.
- 5.** Turn on your mixing console (or other signal source).
- 6.** Turn on the amplifier. Turn up its volume or gain control(s) as recommended by the manufacturer.
- 7.** Start the signal source, whether it be speaking into a microphone or starting a CD player. Adjust the volume controls on the mixer (or other signal source) for normal operation.

Hookup Diagrams

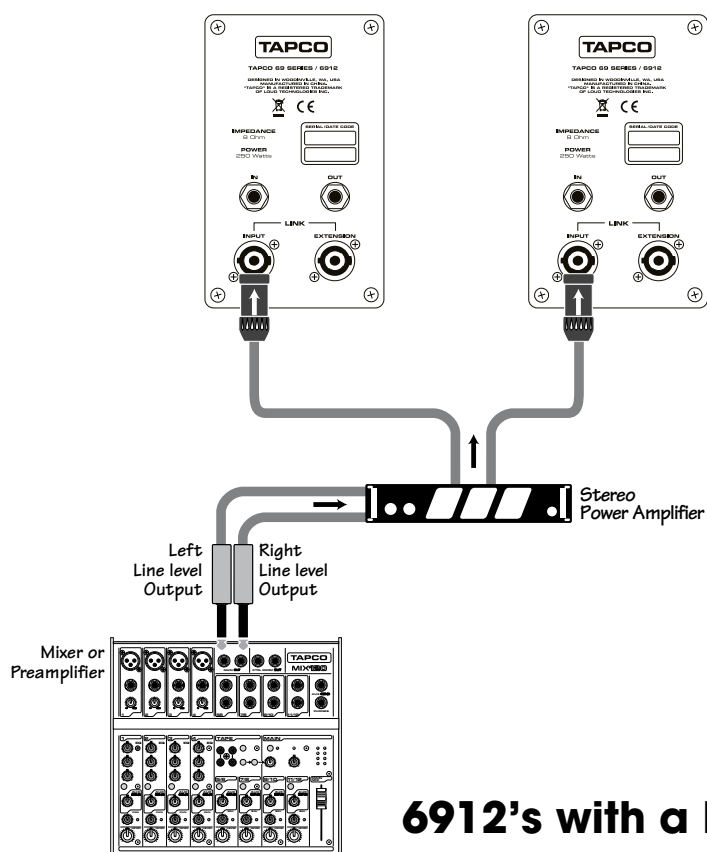

6912's with a Mixer and Power Amplifier

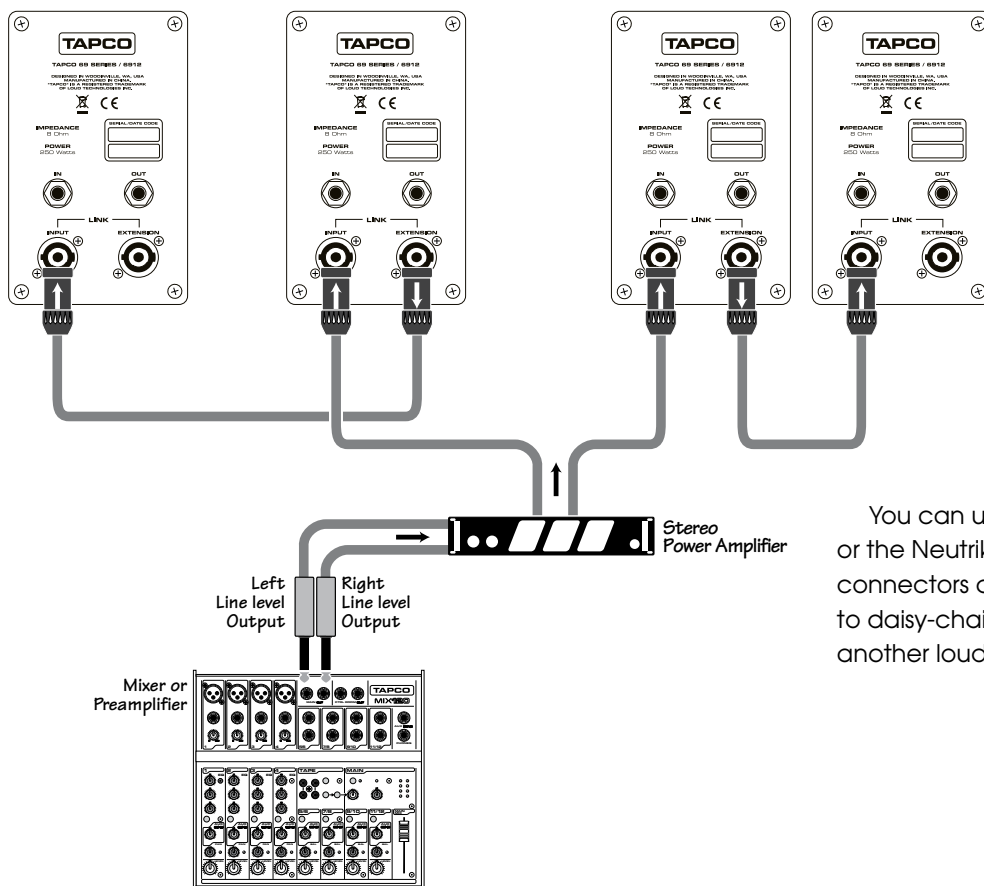

You can use the 1/4" outputs or the Neutrik "Link Extension" connectors as "Thru" connections to daisy-chain the signal to another loudspeaker.

6912's with a Mixer and Power Amplifier, Daisy-Chaining

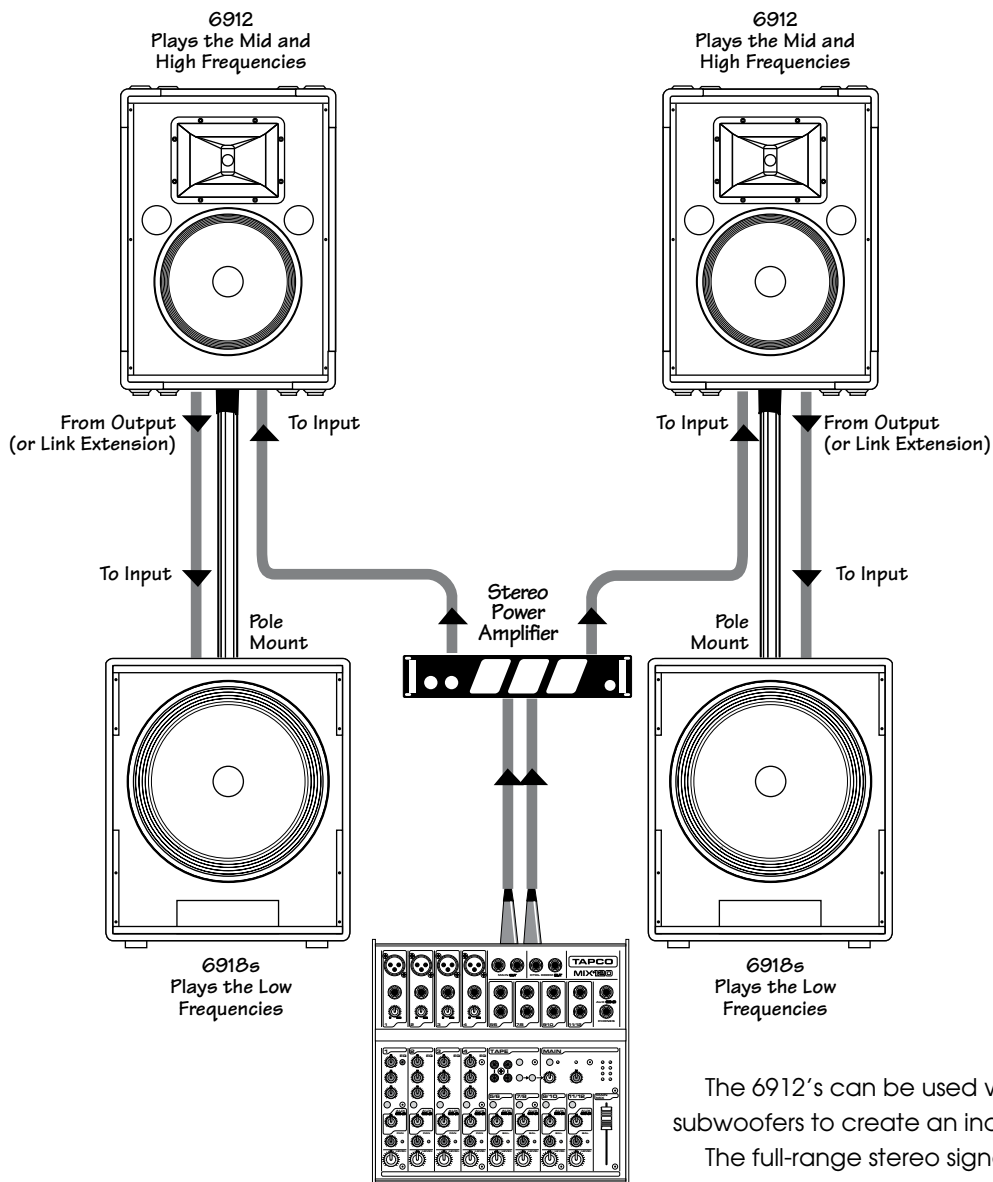

The 6912's can be used with the 6918s subwoofers to create an incredibly powerful system.

The full-range stereo signal from the mixer and power amplifier go to the inputs of the left and right 6912's.

The outputs from the 6912's are connected to the inputs of the 6918s subwoofers, whose internal low-pass filter allows the subwoofers to reproduce only the lowest frequencies.

The 6912's can be pole mounted on top of the 6918s subwoofers as shown.

6912's Daisy-Chained with two 6918s Subwoofers

Placement

Your new Series 69 loudspeakers are designed to sit on the floor or a tabletop. In addition, the 6912 and 6915 are designed to be pole-mounted or fit on a standard tripod speaker stand. The 6925 and 6918s ARE NOT designed to be pole-mounted.



Warning: The Series 69 enclosures have no rigging points and are not suitable for rigging. **NEVER** attempt to suspend any of the Series 69 enclosures by its handles.

As with any loudspeakers, protect them from moisture. If you are setting them up outdoors, make sure they are under cover if you expect rain.

Room Acoustics

The Series 69 loudspeakers are designed to sound as neutral as possible. However, room acoustics play a crucial role in the overall performance of a sound system. Here are some placement tips to get the best performance from the Series 69 loudspeakers:

- Avoid placing loudspeakers in the corners of a room. This increases the low-frequency output and can cause the sound to be muddy and indistinct.
- Avoid placing loudspeakers against a wall. This, too, increases the low-frequency output, though not as much as corner placement. However, if you do need to reinforce the low frequencies, this is a good way to do it.
- Avoid placing the speakers directly on a hollow stage floor. A hollow stage can resonate at certain frequencies, causing peaks and dips in the frequency response of the room. It's better to place the loudspeakers on a sturdy table or tripod stands.
- Position the loudspeakers so the high-frequency drivers are two to four feet above ear level for the audience (make allowances for a standing/dancing-in-the-aisles audience). High frequencies are highly directional and tend to be absorbed much easier than lower frequencies. By providing direct line-of-sight from the loudspeakers to the audience, you increase the overall brightness and intelligibility of the sound system.

- Highly reverberant rooms, like many gymnasiums and auditoriums, are a nightmare for sound system intelligibility. Multiple reflections off the hard walls, ceiling, and floor play havoc with the sound. Depending on the situation, you may be able to take some steps to minimize the reflections, such as putting carpeting on the floors, closing draperies to cover large glass windows, or hanging tapestries or other materials on the walls to absorb some of the sound.

However, in most cases, these remedies are not possible or practical. So what do you do? Making the sound system louder generally doesn't work because the reflections become louder, too.

The best approach is to provide as much direct sound coverage to the audience as possible. The farther away you are from the speaker, the more prominent will be the reflected sound.

Use more speakers strategically placed so they are closer to the back of the audience. If the distance between the front and back speakers is more than about 100 feet, you should use a delay processor to time-align the sound. (Since sound travels about one foot per millisecond, it takes about 1/10 of a second to travel 100 feet).

ADDITIONAL TIDBITS OF WISDOM:

- Never listen to loud music for prolonged periods. Please see the Safety Instructions on page 2 for information on hearing protection.
- When you shut down your equipment, turn off the amplifiers first to prevent thumps and other noises generated by any upstream equipment from coming out the speakers. When powering up, turn on the amplifiers last.
- Save the shipping boxes and packing materials! You may need them someday. Besides, your cat will love playing in them and jumping out at you unexpectedly. Remember to pretend like you are surprised!
- Save your sales receipt in a safe place.
- Also record the serial numbers in the space provided on page 3, along with where and when you bought them.

Protection

HF Protection

A protection circuit is built into the 6912, 6915, and 6925 to protect their high-frequency compression drivers from excessive power. When tripped, the protection circuit substantially reduces the power to the HF driver. After the driver cools to a safe operating temperature, the protection circuit resets and normal operation resumes.

However, if the protection circuit senses excessive power, it will trip again. In this case, it is necessary to reduce the power to the loudspeaker by either turning down the gain controls on the power amplifier or turning down the master volume control on the mixer or other sound source.



CAUTION: The protection circuit is designed to protect the HF driver under reasonable and sensible conditions. Should you choose to ignore the warning

signs (i.e., frequent clip LED indications on the mixer or power amplifier, excessive distortion), you can still damage the drivers in the Series 69 loudspeakers by overdriving them past their recommended amplifier power-handling ratings, or past the point of amplifier clipping. Such damage is beyond the scope of the warranty.

Amplifier Power

We give you two power-handling numbers for the Series 69 loudspeakers: continuous and program. So how much power do you really need to drive the Series 69 loudspeakers?

The answer to that question depends on what type of program material you are running through the system and how loud it needs to be.

Some audio signals have lots of momentary peaks whose amplitudes extend far above the average overall level of the program. Percussion instruments are a good example of this. Other types of signals, like highly compressed rock music, have a higher average signal level with fewer peaks. Speech reinforcement requires less power overall, but involves large moment-to-moment variations in level.

Assuming you want to use the full capability of the loudspeaker, and the program contains at least some momentary peaks, we recommend that you use an amplifier that is rated at twice the continuous power rating of the loudspeaker (into 8 ohms). For the 6912s, this would be $250 \text{ watts} \times 2 = 500 \text{ watts}$ per channel into 8 ohms. This insures that the amplifier can reproduce peaks that are 6 dB higher than the continuous (rms) power-handling rating before clipping occurs.

Recommended Power Ratings

6912	500 watts into 8 ohms (250 watts rms x 2)
6915	600 watts into 8 ohms (300 watts rms x 2)
6925	1200 watts into 8 ohms (600 watts rms x 2)
6918s	900 watts into 8 ohms (450 watts rms x 2)

Preventing Loudspeaker Damage

Speaking of clipping, this is likely the number one cause of damage to loudspeakers. Clipping occurs when the signal at the output of any device in the system (not just the amplifier) reaches its maximum level. The input signal to the device may continue to increase, but the output simply stops, and is characterized by a "flat-top" appearance to the waveform.

Normal Sine Wave Signal ☺

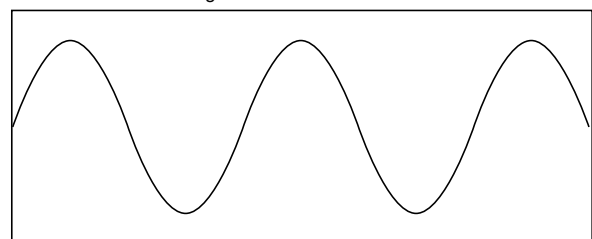

Clipped Sine Wave Signal ☹

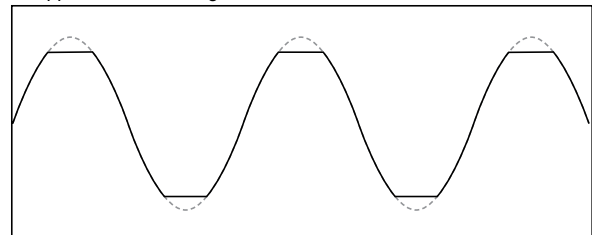

Clipping interrupts the motion of the transducer, creating distortion and excessive heat in the driver, which can damage it over time.

Some folks think that if they use a power amplifier whose power rating is below the maximum power-handling rating of the loudspeaker, then they can't possibly damage the loudspeaker. But if the amplifier is driven into clipping, even a lower power amplifier can damage the loudspeaker.

The bottom line is that to prevent damage to the loudspeakers, you must have a properly operating sound system. Proper operation of a sound system includes being aware of the types of audio signals being reproduced, controlling the output levels accordingly, and operating all the devices in the system so that no clipping occurs within the signal chain.

Appendix A: Service Information

Warranty Service

Details concerning Warranty Service are spelled out in the Warranty section on page 15.

If you think your TAPCO Series 69 loudspeaker has a problem, please do everything you can to confirm it before calling for service. Doing so might save you from the deprivation of your loudspeaker and the associated suffering.

These may sound obvious to you, but here are some things you can check. Read on.

Troubleshooting

No sound

- Are the level controls on the mixer or amplifier turned all the way down? Follow the procedures in the "Getting Started" section on page 4 to verify that all the volume controls in the system are properly adjusted.
- Is the signal source working (and making union scale)?
- Are all the connections good and sound? Make sure all the connecting cables are in good repair and securely connected at both ends.

One side is way louder than the other!

- Are the level controls set the same for both channels on the mixer and amplifier?
- Check the PAN control on the signal source. It may be turned too far to one side. If you're using a stereo signal source, it may be delivering an out-of-balance stereo signal.
- Try swapping sides: Switch the speaker cables coming from the amplifier at the amplifier end. If the other side is louder now, the problem is with the amplifier, the mixer, or the signal source.

Poor bass performance

- Check the polarity of the connections between the amplifier and the loudspeakers. You may have your positive and negative connections reversed at one end of one cable.

Bad sound

- Is the input connector plugged completely into the jack? Make sure it is plugged all the way in.
- Is it loud and distorted? Reduce the signal level at the mixer.
- If possible, listen to the signal source with headphones plugged into the preamp stage. If it sounds bad there, it's not the loudspeaker.
- Keep practicing.

Repair

Service for TAPCO products is available at a factory-authorized service center. Service for TAPCO products living outside the United States can be obtained through local dealers or distributors.

If your loudspeaker needs service, follow these instructions:

1. Review the preceding troubleshooting suggestions. Please.
2. Call Tech Support at 1-877-827-2669, 7 am to 5 pm PST, to explain the problem and obtain a Service Request Number. Have your loudspeaker's serial number ready. **You must have a Service Request Number before you can obtain factory-authorized service.**
3. Keep this owner's manual. We don't need it to repair the loudspeaker.
4. Pack the loudspeaker in its original package, including endcaps and box. This is **VERY IMPORTANT**. When you call for the Service Request Number, please let Tech Support know if you need new packaging. **TAPCO is not responsible for any damage that occurs due to non-factory packaging.**
5. Include a legible note stating your name, shipping address (no P.O. boxes), daytime phone number, Service Request Number, and a detailed description of the problem, including how we can duplicate it.
6. Write the Service Request Number in **BIG PRINT** on top of the box. Units sent without the Service Request Number will be refused.
7. Tech Support will tell you where to ship the loudspeaker for repair. We suggest insurance for all forms of cartage.
8. You will need to contact the authorized service center for their latest turn-around times. The loudspeaker must be packaged in its original packing box, and must have the Service Request Number on the box. Once it's repaired, the authorized service center will ship it back, pre-paid (if it was a warranty repair).

Note: Under the terms of the warranty, you must ship or drop-off the unit to an authorized service center. The return ground shipment is covered for those units deemed by us to be under warranty.

Note: You must have a sales receipt from an authorized TAPCO dealer to qualify for a warranty repair.

Care and Maintenance

Your TAPCO loudspeakers will provide many years of reliable service if you follow these simple guidelines:

- Avoid exposing the loudspeakers to moisture. If they are set up outdoors, be sure they are under cover if you expect rain.
- Avoid exposure to extreme cold (below freezing temperatures). If you must operate the loudspeakers in a cold environment, warm up the

voice coils slowly by sending a low-level signal through them for about 15 minutes prior to high-power operation.

- Use a damp cloth with a mild soap solution to clean the cabinets. Avoid getting moisture into any of the openings of the cabinet, particularly where the drivers are located.

Appendix B: Connections

Use heavy gauge, stranded wire for connecting a speaker to the output of a power amplifier. **Do not use a guitar cord to make this connection.** They aren't designed to handle the high currents produced by a power amplifier and can overheat.

As the distance between the amplifier and speakers increases, the thickness of the wire should also increase. Speaker wire has resistance, and when electricity passes through a resistor, power is lost. The thicker the wire, the less resistance it offers, and the more power actually gets to the speaker.

1/4" TS Phone Plugs and Jacks

"TS" stands for Tip-Sleeve, the two connections available on a mono 1/4" phone jack or plug. They are used for unbalanced signals and speaker connections.

1/4" TS Wiring:

Sleeve = Cold (-)

Tip = Hot (+)

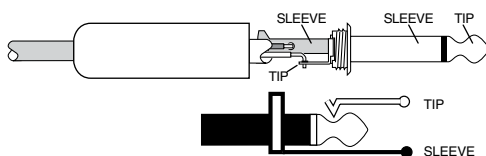

NL4-Type Plugs and Jacks

This connector is compatible with the popular Neutrik® Speakon® 4-pole plugs. These connectors are designed to handle the higher currents produced by amplifiers, and have a locking feature to prevent accidental disconnections. Simply line up the tabs on the plug with the jack on the Series 69 connector panel, push it in, and rotate it 1/4 turn to the right to lock it in place.

NL4 Wiring:

Pin 1 - = Cold (-)

Pin 1 + = Hot (+)

Pin 2 - = No Connection

Pin 2 + = No Connection

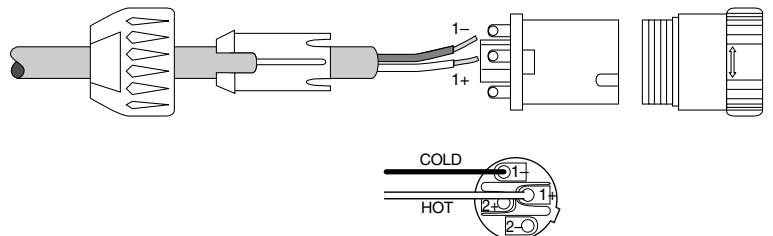

Lonely? Looking for that special someone? Do you have a question about your TAPCO loudspeaker?

Please call our Technical Support chaps at **1-877-827-2669**, Monday to Friday, from 7 AM to 5 PM PST.

After hours, visit www.tapcoworld.com and look under **Support**, or e-mail us at techmail@tapcogear.com

Flash From The Past

"Good morning. What we have in mind is breakfast in bed for 400,000!"
- Wavy Gravy at the Woodstock Festival & Concert, 1969



Appendix C: Specifications

6912 Specifications System

System Type: Two-way, full-range loudspeaker
 Frequency Range (-10 dB): 49 Hz to 18 kHz
 Sensitivity (1W @ 1m): 99.9 dB SPL
 Nominal Impedance: 8 ohms
 Power Handling: 250 watts continuous
 500 watts program

Transducers

Low Frequency: 12 in/305 mm woofer, vented
 High Frequency: 1 in/25 mm tweeter,

Physical

Input Connectors: One 1/4" TS jack,
 one Speakon jack, paralleled
 Enclosure: Wood with textured black
 PVC vinyl covering
 Dimensions:
 Height: 25.6 in/65.1 cm
 Width: 17.8 in/45.1 cm
 Depth: 15.6 in/39.6 cm
 Weight: 49 lb/22 kg
 Mounting: Pole-mountable

6915 Specifications System

System Type: Two-way, full-range loudspeaker
 Frequency Range (-10 dB): 47 Hz to 18 kHz
 Sensitivity (1W @ 1m): 101.1 dB SPL
 Nominal Impedance: 8 ohms
 Power Handling: 300 watts continuous
 600 watts program

Transducers

Low Frequency: 15 in/381 mm woofer, vented
 High Frequency: 1 in/25 mm tweeter,

Physical

Input Connectors: One 1/4" TS jack,
 one Speakon jack, paralleled
 Enclosure: Wood with textured black
 PVC vinyl covering
 Dimensions:
 Height: 28.1 in/71.4 cm
 Width: 17.8 in/45.1 cm
 Depth: 15.6 in/39.6 cm
 Weight: 51 lb/23 kg
 Mounting: Pole-mountable

6912 Dimensions

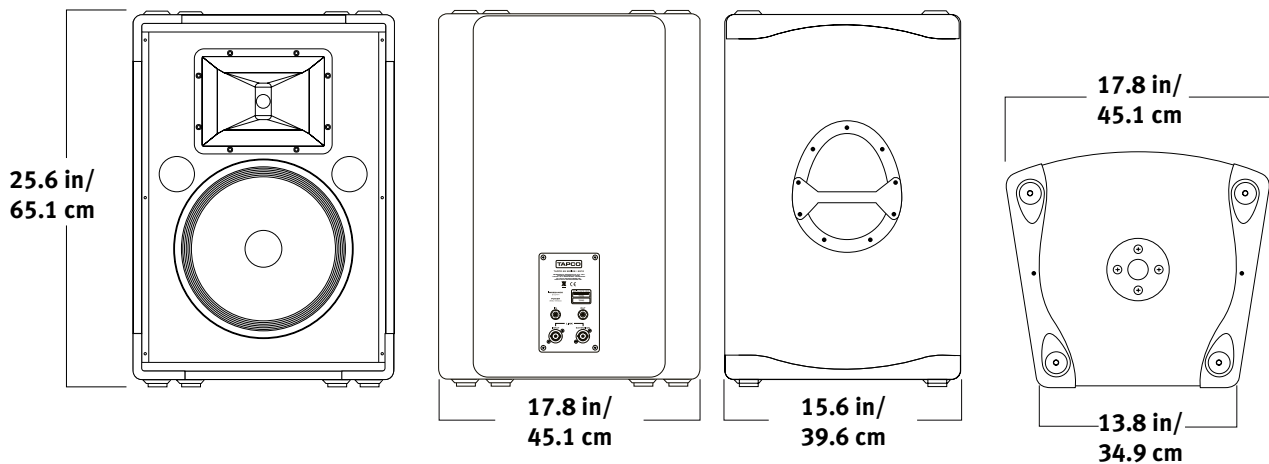

6915 Dimensions

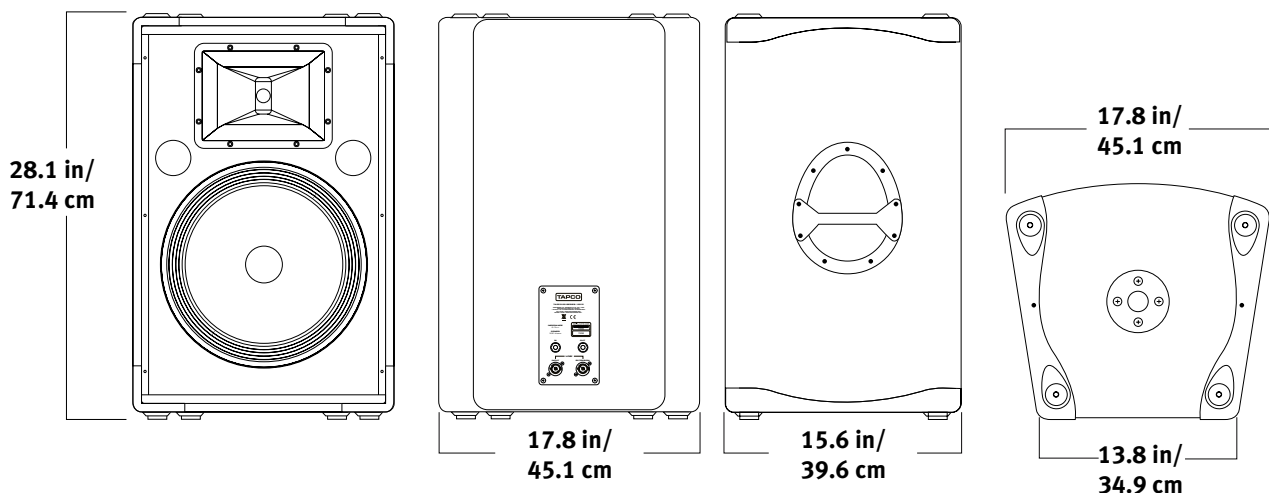

6925 Specifications System

System Type: Two-way, full-range loudspeaker
 Frequency Range (-10 dB): 51 Hz to 18 kHz
 Sensitivity (1W @ 1m): 102.9 dB SPL
 Nominal Impedance: 8 ohms
 Power Handling: 600 watts continuous
 1200 watts program

Transducers

Low Frequency: Two 15 in/381 mm woofers, vented
 High Frequency: 1 in/25 mm tweeter,

Physical

Input Connectors: One 1/4" TS jack,
 one Speakon jack, paralleled
 Enclosure: Wood with textured black
 PVC vinyl covering
 Dimensions:
 Height: 43.9 in/111.5 cm
 Width: 16.8 in/42.5 cm
 Depth: 15.6 in/39.6 cm
 Weight: 75 lb/34 kg

6918s Specifications System

System Type: Subwoofer
 Frequency Range (-10 dB): 37 Hz to 220 Hz
 Sensitivity (1W @ 1m): 98.3 dB SPL
 Nominal Impedance: 8 ohms
 Power Handling: 450 watts continuous
 900 watts program

Transducers

Low Frequency: 18 in/457 mm woofer, vented

Physical

Input Connectors: One 1/4" TS jack,
 one Speakon jack, paralleled
 Enclosure: Wood with durable black paint
 Dimensions:
 Height: 23.9 in/60.7 cm
 Width: 20.3 in/51.4 cm
 Depth: 21.3 in/54.0 cm
 Weight: 70 lb/32 kg
 Mounting: Pole-mount on top

6925 Dimensions

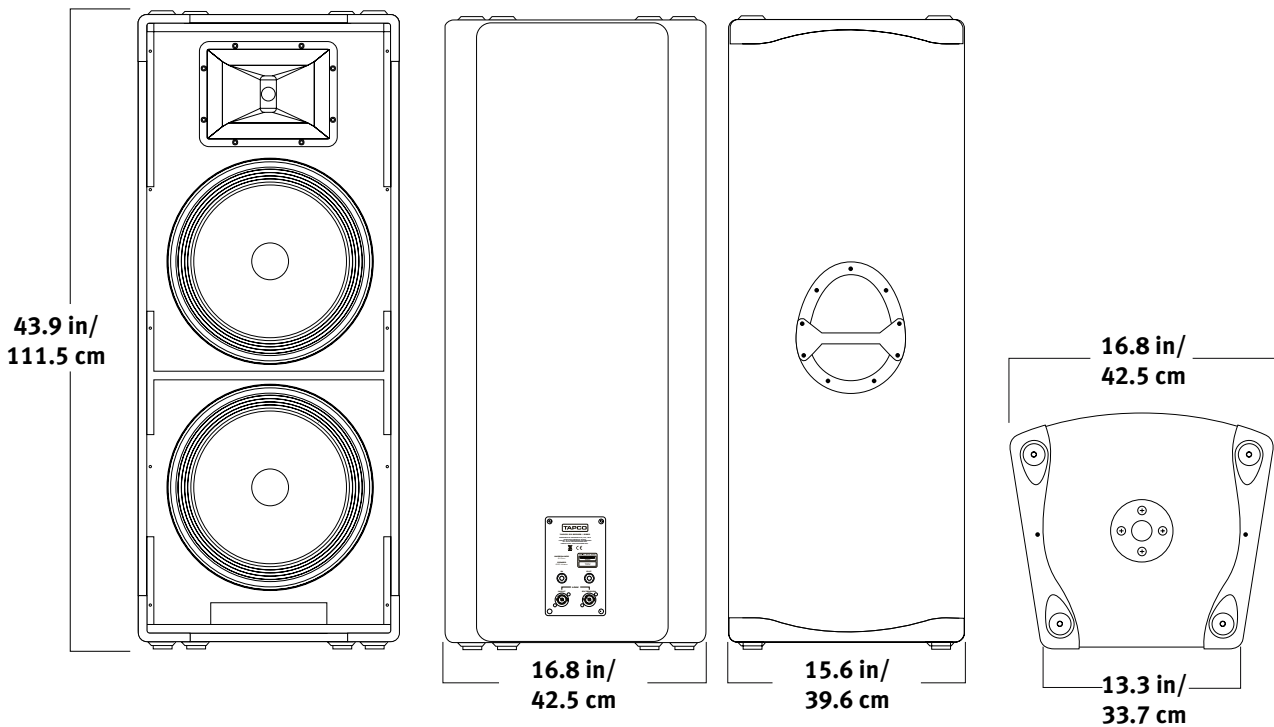

6918s Dimensions

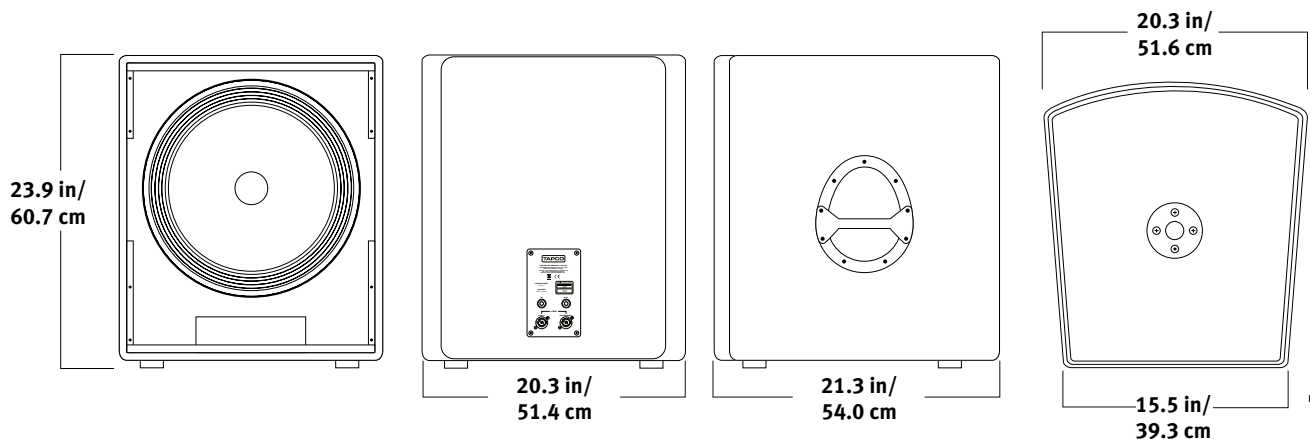

Disclaimer

Since we are always striving to make our products better by incorporating new and improved materials, components, and manufacturing methods, we reserve the right to change these specifications at any time without notice.

"TAPCO" is a registered trademark of LOUD Technologies Inc. All other brand names mentioned are trademarks or registered trademarks of their respective holders, and are hereby acknowledged.

©2006 LOUD Technologies Inc. All Rights Reserved.

TAPCO LIMITED WARRANTY

- A.** LOUD Technologies Inc. warrants all materials, workmanship and proper operation of this TAPCO product for a period of **one year** from the original date of purchase. If any defects are found in the materials or workmanship, or if the product fails to function properly during the applicable warranty period, LOUD Technologies, at its option, will repair or replace the product. **This warranty applies only to equipment sold and delivered within the U.S. by LOUD Technologies or its authorized dealers.**
- B.** Failure to register online or return the product registration card will not void the one-year warranty.
- C.** Service and repairs of TAPCO products are to be performed only at a factory-authorized service center. Unauthorized service, repairs, or modification will void this warranty. To obtain repairs under warranty, you must have a copy of your sales receipt from the authorized TAPCO dealer where you purchased the product. It is necessary to establish purchase date and determine whether your TAPCO product is within the warranty period.
- D.** To obtain factory-authorized service:
- 1.** Call TAPCO Technical Support at 877/827-2669, 7 AM to 5 PM Monday through Friday (Pacific time) to get a Service Request Number. Products returned without a Service Request Number will be refused.
 - 2.** Pack the product in its original shipping carton. Also include a note explaining exactly how to duplicate the problem, a copy of the sales receipt with price and date showing, and your return street address (no P.O. boxes or route numbers, please!). If we cannot duplicate the problem or establish the starting date of your Limited Warranty, we may, at our option, charge for service time.
 - 3.** Ship the product in its original shipping carton, freight prepaid, to the authorized service center. The address of your closest authorized service center will be given to you by Technical Support.
- IMPORTANT: Make sure that the Service Request Number is plainly written on the shipping carton.**
- E.** LOUD Technologies Inc. reserves the right to inspect any products that may be the subject of any warranty claims before repair or replacement is carried out. LOUD Technologies may, at their option, require proof of the original date of purchase in the form of a dated copy of the original dealer's invoice or sales receipt. Final determination of warranty coverage lies solely with LOUD Technologies Inc.
- F.** TAPCO products returned to one of the LOUD Technologies factory-authorized service centers and deemed eligible for repair or replacement under the terms of this warranty will be repaired or replaced within thirty days of receipt. LOUD Technologies and its authorized service centers may use refurbished parts for repair or replacement of any product. Products returned to LOUD Technologies that do not meet the terms of this Warranty will not be repaired until payment is received for labor, materials, return freight, and insurance. Products repaired under warranty will be returned freight prepaid by LOUD Technologies to any location within the boundaries of the USA.
- G.** LOUD Technologies warrants all repairs performed for 90 days or for the remainder of the original warranty period. This warranty does not extend to damage resulting from improper installation, misuse, neglect or abuse, or to exterior appearance. This warranty is recognized only if the inspection seals and serial number on the unit have not been defaced or removed.
- H.** LOUD Technologies assumes no responsibility for the quality or timeliness of repairs performed by Authorized TAPCO Service Centers.
- I.** This warranty is extended to the original purchaser and to anyone who may subsequently purchase this product within the applicable warranty period. A copy of the sales receipt is required to obtain warranty repairs.
- J.** This is your sole warranty. LOUD Technologies Inc. does not authorize any third party, including any dealer or sales representative, to assume any liability on behalf of LOUD Technologies or to make any warranty for LOUD Technologies.
- K.** THE WARRANTY GIVEN ON THIS PAGE IS THE SOLE WARRANTY GIVEN BY LOUD TECHNOLOGIES INC. AND IS IN LIEU OF ALL OTHER WARRANTIES, EXPRESS AND IMPLIED, INCLUDING THE WARRANTIES OF MERCHANTABILITY AND FITNESS FOR A PARTICULAR PURPOSE. THE WARRANTY GIVEN ON THIS PAGE SHALL BE STRICTLY LIMITED IN DURATION TO ONE YEAR FROM THE DATE OF ORIGINAL PURCHASE FROM AN AUTHORIZED TAPCO DEALER. UPON EXPIRATION OF THE APPLICABLE WARRANTY PERIOD, LOUD TECHNOLOGIES INC. SHALL HAVE NO FURTHER WARRANTY OBLIGATION OF ANY KIND. LOUD TECHNOLOGIES INC. SHALL NOT BE LIABLE FOR ANY INCIDENTAL, SPECIAL, OR CONSEQUENTIAL DAMAGES THAT MAY RESULT FROM ANY DEFECT IN THE TAPCO PRODUCT OR ANY WARRANTY CLAIM. Some states do not allow exclusion or limitation of incidental, special, or consequential damages or a limitation on how long warranties last, so some of the above limitations and exclusions may not apply to you. This warranty provides specific legal rights and you may have other rights which vary from state to state.

Please keep your sales receipt in a safe place.



www.tapcoworld.com

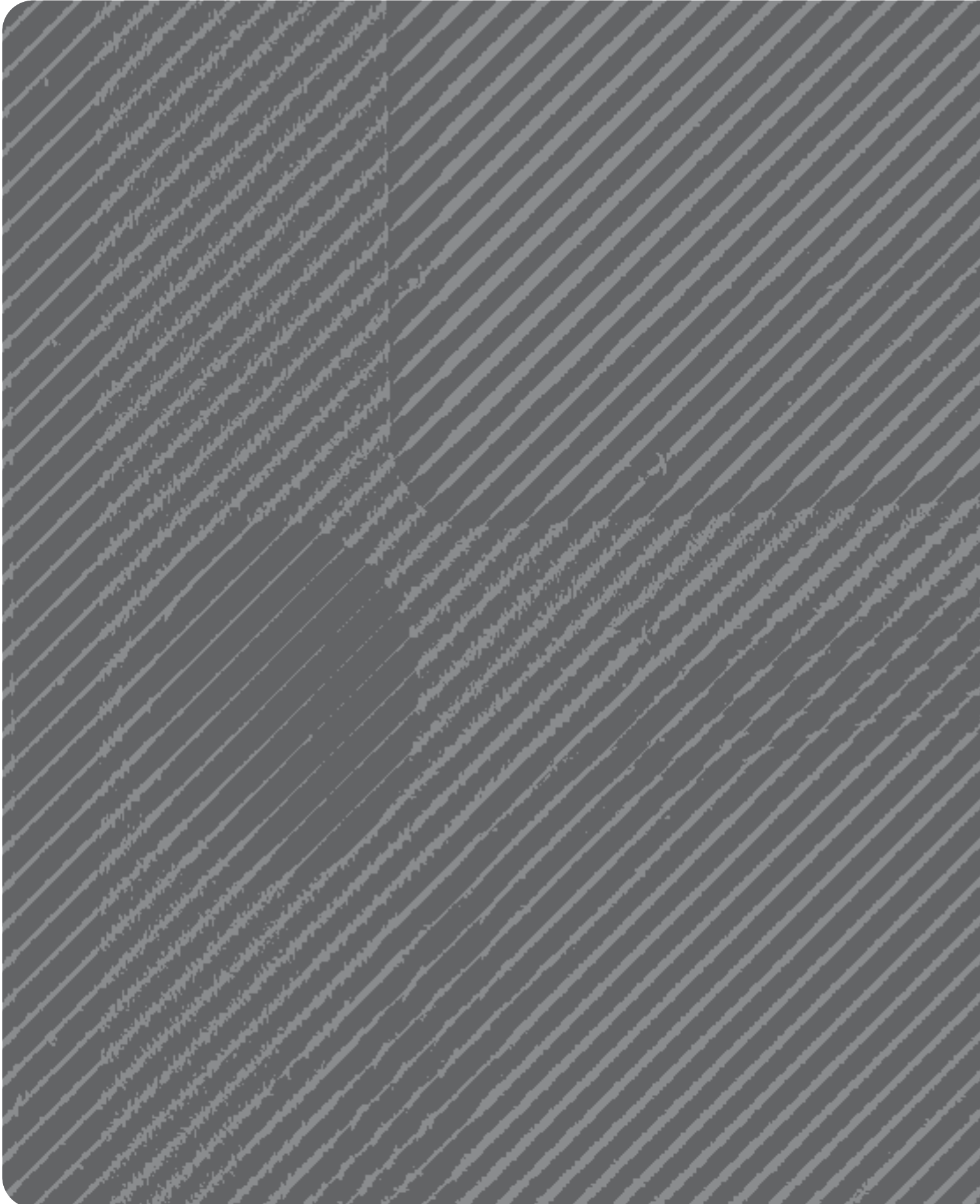

Free Manuals Download Website

<http://myh66.com>

<http://usermanuals.us>

<http://www.somanuals.com>

<http://www.4manuals.cc>

<http://www.manual-lib.com>

<http://www.404manual.com>

<http://www.luxmanual.com>

<http://aubethermostatmanual.com>

Golf course search by state

<http://golfingnear.com>

Email search by domain

<http://emailbydomain.com>

Auto manuals search

<http://auto.somanuals.com>

TV manuals search

<http://tv.somanuals.com>