

SHARP

MINI COMPONENT SYSTEM

OPERATION MANUAL

COMPACT
disc
DIGITAL AUDIO

MODEL
CD-PC3500

CD-PC3500 Mini Component System consisting of CD-PC3500 (main unit), CP-C3500 (front speakers), GBOXS0036AWM1 (center speaker) and GBOXS0037AWM1 (rear speakers).

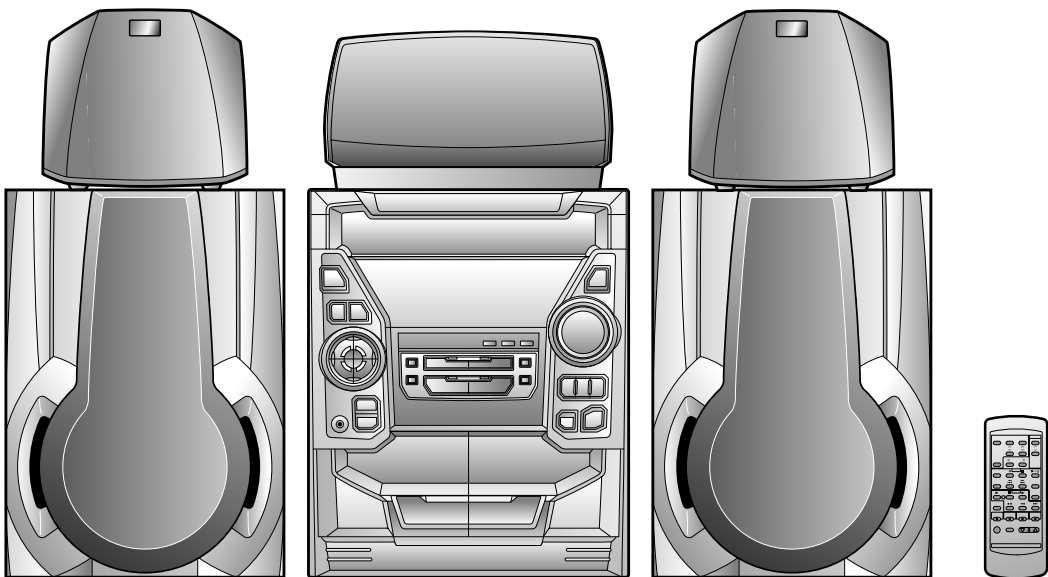

Note:

This equipment has been tested and found to comply with the limits for a Class B digital device, pursuant to Part 15 of the FCC Rules. These limits are designed to provide reasonable protection against harmful interference in a residential installation.

This equipment generates, uses, and can radiate radio frequency energy and, if not installed and used in accordance with the instructions, may cause harmful interference to radio communications.

However, there is no guarantee that interference will not occur in a particular installation. If this equipment does cause harmful interference to radio or television reception, which can be determined by turning the equipment off and on, the user is encouraged to try to correct the interference by one or more of the following measures:

- Reorient or relocate the receiving antenna.
- Increase the separation between the equipment and receiver.
- Connect the equipment into an outlet on a circuit different from that to which the receiver is connected.
- Consult the dealer or an experienced radio/TV technician for help.

WARNING

FCC Regulations state that any unauthorized changes or modifications to this equipment not expressly approved by the manufacturer could void the user's authority to operate this equipment.

FOR YOUR RECORDS

For your assistance in reporting this unit in case of loss or theft, please record below the model number and serial number which are located on the rear of the unit.

Please retain this information.

Model number _____

Serial number _____

Date of purchase _____

Place of purchase _____



The lightning flash with arrowhead symbol, within an equilateral triangle, is intended to alert the user to the presence of uninsulated "dangerous voltage" within the product's enclosure that may be of sufficient magnitude to constitute a risk of electric shock to persons.

CAUTION
RISK OF ELECTRIC SHOCK
DO NOT OPEN

CAUTION: TO REDUCE THE RISK OF ELECTRIC SHOCK, DO NOT REMOVE COVER (OR BACK). NO USER-SERVICEABLE PARTS INSIDE. REFER SERVICING TO QUALIFIED SERVICE PERSONNEL.



The exclamation point within an equilateral triangle is intended to alert the user to the presence of important operating and maintenance (servicing) instructions in the literature accompanying the appliance.

Caution - use of controls or adjustments or performance of procedures other than those specified herein may result in hazardous radiation exposure.

WARNING: TO REDUCE THE RISK OF FIRE OR ELECTRIC SHOCK, DO NOT EXPOSE THIS APPLIANCE TO RAIN OR MOISTURE.

IMPORTANT SAFEGUARDS

CAUTION

All the safety and operating instructions should be read before the appliance is operated, and should be retained for future reference.

Electrical energy can perform many useful functions. This unit has been engineered and manufactured to assure your personal safety. Improper use can result in potential electrical shock or fire hazards. In order not to defeat the safeguards, observe the following basic rules for its installation, use and servicing.

- 1 Heed Warnings - All warnings on the appliance and in the operating instructions should be adhered to.
- 2 Follow Instructions - All operating and use instructions should be followed.
- 3 Water and Moisture - The appliance should not be used near water - for example, near a bathtub, washbowl, kitchen sink, laundry tub, in a wet basement, or near a swimming pool, etc.
- 4 Carts and Stands - The appliance should be used only with a cart or stand that is recommended by the manufacturer.

- An appliance and cart combination should be moved with care. Quick stops, excessive force, and uneven surfaces may cause the appliance and cart combination to overturn.



- 5 Wall or Ceiling Mounting - The appliance should be mounted to a wall or ceiling only as recommended by the manufacturer.
- 6 Ventilation - The appliance should be situated so that its location or position does not interfere with its proper ventilation. For example, the appliance should not be situated on a bed, sofa, rug, or similar surface that may block the ventilation openings; or, placed in a built-in installation, such as a bookcase or cabinet that may impede the flow of air through the ventilation openings.
- 7 Heat - The appliance should be situated away from heat sources such as radiators, heat registers, stoves, or other appliances (including amplifiers) that produce heat.
- 8 Power Sources - The appliance should be connected to a power supply only of the type described in the operating instructions or as marked on the appliance.
- 9 Power-Cord Protection - Power-supply cords should be routed so that they are not likely to be walked on or pinched by items placed upon or against them, paying particular attention to cords at plugs, convenience receptacles, and the point where they exit from the appliance.
- 10 Do not use liquid cleaners or aerosol cleaners. Use a damp cloth for cleaning.
- 11 Power Lines - An outdoor antenna should be located away from power lines.

- 12 Outdoor Antenna Grounding - If an outside antenna is connected to the receiver, be sure the antenna system is grounded so as to provide some protection against voltage surges and built-up static charges. Section 810 of the National Electrical Code, ANSI/NFPA No. 70-1984, provides information with respect to proper grounding of the mast and supporting structure, grounding of the lead-in wire to an antenna discharge unit, size of grounding conductors, location of antenna-discharge unit, connection to grounding electrodes, and requirements for the grounding electrode.

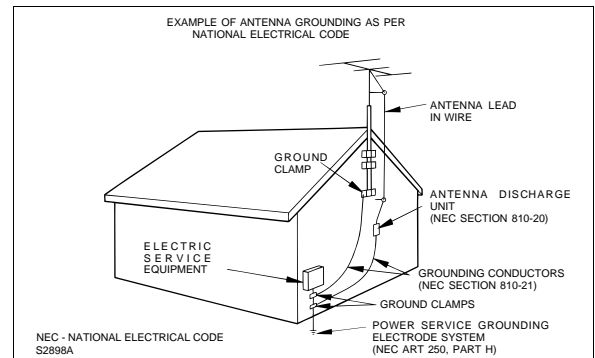

- 13 Nonuse Periods - The power cord of the appliance should be unplugged from the outlet when left unused for a long period of time.
- 14 Object and Liquid Entry - Care should be taken so that objects do not fall and liquids are not spilled into the enclosure through openings.
- 15 Damage Requiring Service - The appliance should be serviced by qualified service personnel when:
 - A The power-supply cord or the plug has been damaged; or
 - B Objects have fallen, or liquid has been spilled into the appliance; or
 - C The appliance has been exposed to rain; or
 - D The appliance does not appear to operate normally or exhibits a marked change in performance; or
 - E The appliance has been dropped, or the enclosure damaged.
- 16 Servicing - The user should not attempt to service the appliance beyond that described in the operating instructions. All other servicing should be referred to qualified service personnel.
- 17 Grounding or Polarization - Precautions should be taken so that the grounding or polarization means of an appliance is not defeated.

INTRODUCTION

Thank you for purchasing this SHARP product.
To obtain the best performance from this product, please read this manual carefully.
It will guide you in operating your SHARP product.

CONTENTS

	Page		Page
ACCESSORIES	2	CASSETTE OPERATION	17
SPECIAL NOTES	2	RECORDING	18
PRECAUTIONS	3	HOW TO USE THE BUILT-IN TIMER	19-20
NAMES OF CONTROLS AND INDICATORS	4-6	USING EXTERNAL UNITS	20-21
PREPARATION FOR USE	6-9	RESETTING THE MICROCOMPUTER	21
SOUND CONTROL	10-11	MAINTENANCE	21
SETTING THE CLOCK	12	TRANSPORTING THE UNIT	22
COMPACT DISC OPERATION	13-15	SPECIFICATIONS	22
RADIO OPERATION	16-17	CONSUMER LIMITED WARRANTY	Back cover

ACCESSORIES

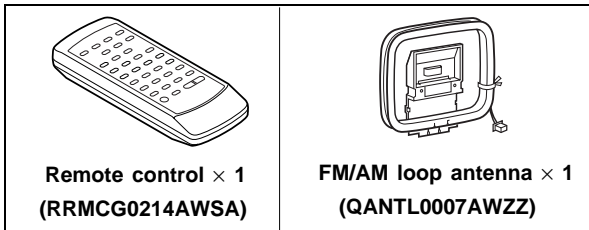

Note:

Parts and accessories mentioned in this operation manual other than those in the drawing are not included.

SPECIAL NOTES



Manufactured under license from Dolby Laboratories Licensing Corporation.

DOLBY, the double-D symbol  and "PRO LOGIC" are trademarks of Dolby Laboratories Licensing Corporation.

- It is the intent of Sharp that this product be used in full compliance with the copyright laws of the United States and that prior permission be obtained from copyright owners whenever necessary.

PRECAUTIONS

General

- Please make sure that the unit is positioned in a well ventilated area and that there is at least 4" (10 cm) of free space along the sides and back. There must also be a minimum of 8" (20 cm) of free space on the top of the unit.
- Do not use oil, solvents, gasoline, paint thinners or insecticides on the unit.
- Do not expose the unit to moisture, to temperatures higher than 140°F (60°C) or to extreme low temperatures.
- Keep the unit away from direct sunlight, strong magnetic fields, excessive dust, humidity and electronic/electrical equipment (home computers, facsimiles, etc.) which generates electrical noise.
- Hold the AC power plug by the head when removing it from the AC outlet, as pulling the cord can damage internal wires.
- When cleaning the heads, pinch rollers, etc, remove the AC power plug from the AC outlet as the unit contains high voltages.
Do not remove the outer cover, as this may result in electric shock. Refer internal service to your local SHARP service facility.
- Use the unit on a firm, level surface free from vibration, and do not place anything on the top of the unit.
- If the unit does not work properly while in use, disconnect the AC power cord from the AC outlet. Plug the AC power cord back in, and then press the ON/STAND-BY button to turn the power on.
- If an electrical storm is taking place near you, it is suggested that you disconnect the AC power cord from the AC outlet for safety.

Warning:

The voltage used must be the same as that specified on this unit. Using this product with a higher voltage other than which is specified is dangerous and may result in a fire or other type of accident causing damage. SHARP will not be held responsible for any damage resulting from use of this unit with a voltage other than that which is specified.

Volume control

The sound level at a given volume setting depends on a combination of speaker efficiency, location and various other factors.

It is advisable to avoid exposure to high volume levels, which occur while turning the unit on with the volume control setting up high, or while continually listening at high volumes.

Condensation

Sudden temperature changes, storage or operation in an extremely humid environment may cause condensation inside the cabinet (CD pickup, tape heads, etc.) or on the transmitter LED on the remote control.

Condensation can cause the unit to malfunction. If this happens, leave the power on with no disc (or cassette) in the unit until normal playback is possible (about 1 hour). Wipe off any condensation on the transmitter LED with a soft cloth before operating the unit.

Care of compact discs

Compact discs are fairly resistant to damage, however mistracking can occur due to an accumulation of dirt on the disc surface.

Follow the guidelines below for maximum enjoyment from your CD collection and player.

- Do not write on either side of the disc, particularly the non-label side. Signals are read from the non-label side. Do not mark this surface.
- Keep your discs away from direct sunlight, heat, and excessive moisture.
- Always hold the CDs by the edges. Fingerprints, dirt, or water on the CDs can cause noise or mistracking. If a CD is dirty or does not play properly, clean it with a soft, dry cloth, wiping straight out from the center, along the radius.

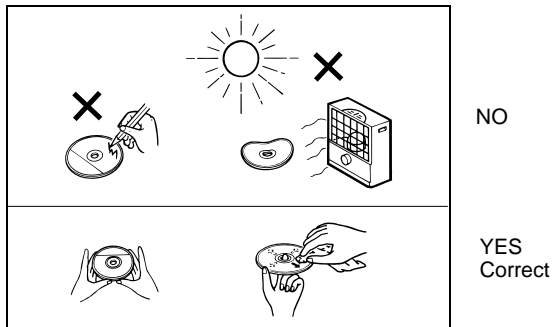

Cassette tape

- For playback, use normal or low-noise tape for the best sound. (Metal or CrO₂ tape is not recommended.) For recording, use only normal tape.
- Do not use C-120 tapes, tapes with large diameter reels, or poor-quality tapes, as they may cause malfunctions.
- Before loading a tape into the cassette compartment, tighten the slack with a pen or pencil.
- Cassettes have removable tabs which prevent accidental recording or erasing from taking place. Removing the tab will protect the corresponding side from being erased. Cover the tab holes with adhesive tape to erase or record again.
- TAPE 1: Playback only.
TAPE 2: Playback or record.

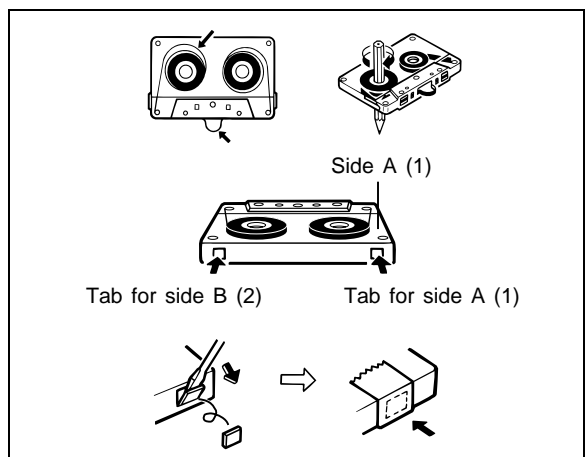

NAMES OF CONTROLS AND INDICATORS

■ Front panel

1. (CD) Disc Tray
2. Extra Bass Indicator
3. Spectrum Analyzer/Volume Level Indicator
4. (CD) Disc Number Indicators
5. (CD/TUNER) Memory Indicator
6. (TAPE 2) Record Indicator
7. (CD) Play Indicator
8. (CD) Music Schedule Indicators
9. (CD) More Tracks Indicator
10. Sleep Indicator
11. FM Stereo Mode Indicator
12. (CD) Random Play Indicator
13. (CD) Pause Indicator
14. (TAPE) Play Indicator
15. (CD) Repeat Indicator
16. FM Stereo Indicator
17. Timer Record Indicator
18. Timer Play Indicator
19. Memory/Set Button
20. (CD) Track Down/Review Button
(TUNER) Preset Down Button
(TAPE 2) Rewind Button
21. Bypass Button
22. (CD) Track Up/Cue Button
(TUNER) Preset Up Button
(TAPE 2) Fast Forward Button
23. Normal Button
24. Phantom Button
25. Timer Set Indicator
26. On/Stand-by Button
27. Clock Button
28. Timer/Sleep Button
29. Function Selector Buttons
30. Dimmer Button
31. Volume Control
32. Equalizer Mode Selector Button
33. (CD) Disc Number Select Buttons
34. Headphone Jack
35. Tuning/Time Up/Down Buttons
36. (TAPE 2) Record Pause Button
37. (CD/TAPE) Stop Button
38. (CD) Play/Repeat Button
(TAPE) Play Button
39. Extra Bass/Demo Mode Button
40. (CD) Disc Skip Button
41. (CD) Open/Close Button
42. (TAPE 1) Cassette Compartment
43. (TAPE 2) Cassette Compartment

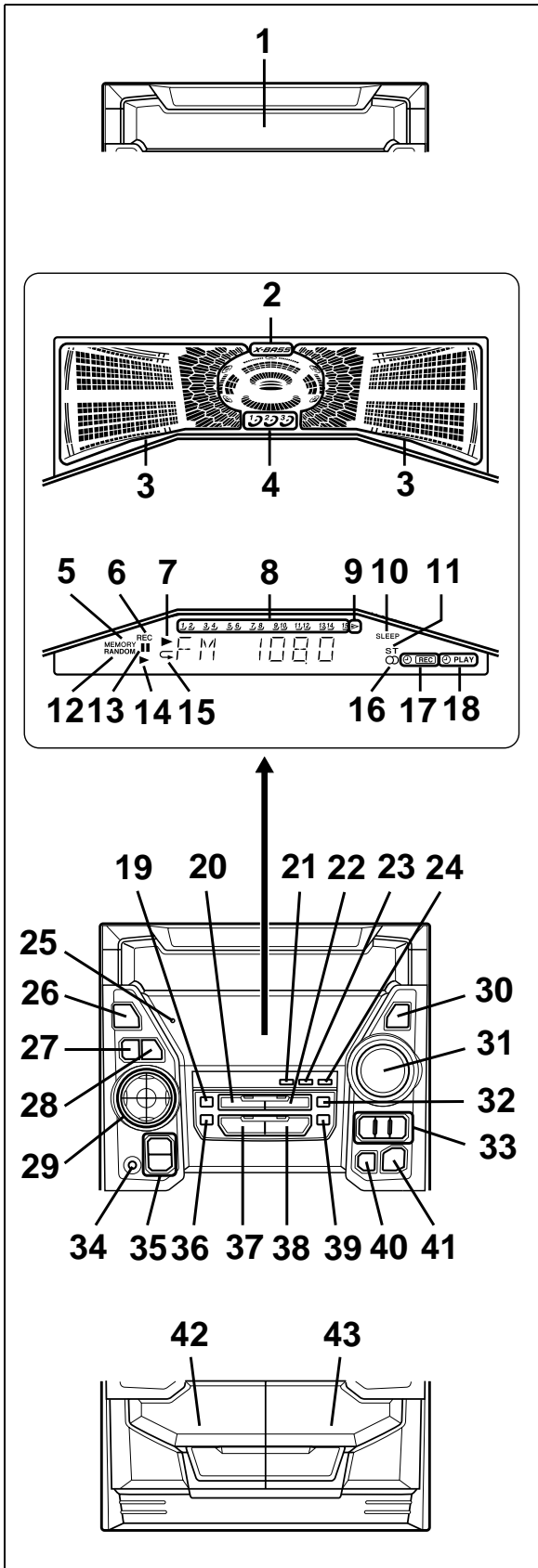

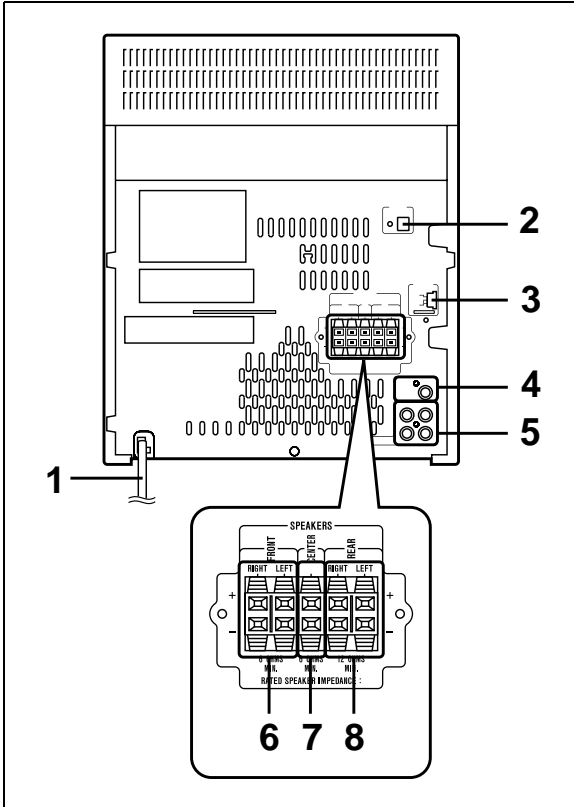

■ Rear panel

1. AC Power Cord
2. CD Digital Output Jack
3. FM/AM Loop Antenna Jack
4. Subwoofer Output Jack
5. Video/Auxiliary (Audio Signal) Input Jacks
6. Front Speaker Terminals
7. Center Speaker Terminals
8. Rear Speaker Terminals

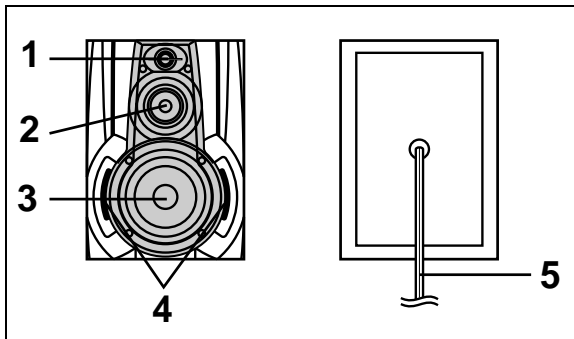

■ Front speaker

1. Super Tweeter
2. Tweeter
3. Woofer
4. Bass Reflex Ducts
5. Speaker Wire

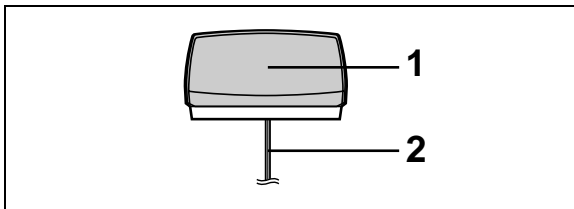

■ Center speaker

1. Full-Range Speaker
2. Speaker Wire

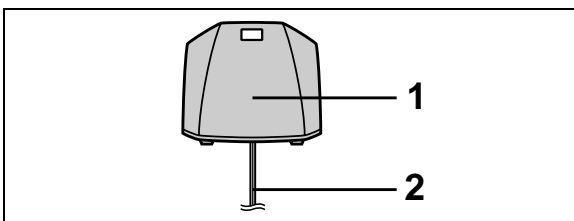

■ Rear speaker

1. Full-Range Speaker
2. Speaker Wire

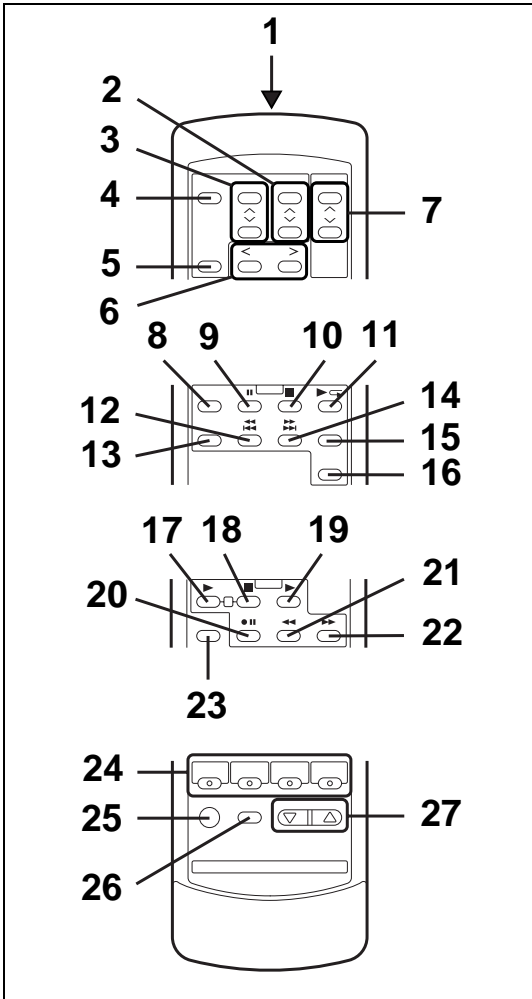

■ Remote control

1. Remote Control Transmitter LED

- 2. Surround Level Buttons
- 3. Center Level Buttons
- 4. Dolby Pro Logic Surround Mode Button
- 5. Test Tone Button
- 6. Balance Control Buttons

● Tuner control section

7. Preset Up/Down Buttons

● CD control section

- 8. Memory Button
- 9. Pause Button
- 10. Stop Button
- 11. Play/Repeat Button
- 12. Track Down/Review Button
- 13. Clear Button
- 14. Track Up/Cue Button
- 15. Random Button
- 16. Disc Skip Button

● Tape control section

- 17. (TAPE 1) Play Button
- 18. (TAPE 1/2) Stop Button
- 19. (TAPE 2) Play Button
- 20. (TAPE 2) Record Pause Button
- 21. (TAPE 2) Rewind Button
- 22. (TAPE 2) Fast Forward Button

- 23. Equalizer Mode Button
- 24. Function Selector Buttons
- 25. On/Stand-by Button
- 26. Extra Bass Button
- 27. Volume Up/Down Buttons

PREPARATION FOR USE

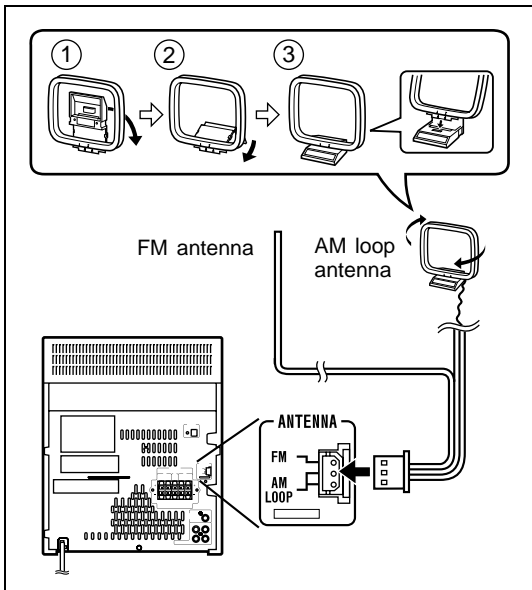

● Unplug the AC power cord from the AC outlet before connecting or disconnecting any component.

■ Antenna connection

Connect the antenna wire to the ANTENNA jack.

FM antenna

Position the FM antenna wire in the direction where the strongest signal can be received.

AM loop antenna

Position the AM loop antenna for optimum reception. Place the AM loop antenna on a shelf, etc., or attach it to a stand or wall with screws (not supplied).

Notes:

- Do not place the antenna on the main unit as it may result in noise pickup from the internal digital electronics. Place the antenna away from the unit for better reception.
- If the AM loop antenna and the FM antenna wire are placed near the AC power cord, interference may result.
- Do not connect the attached FM antenna to an outdoor FM antenna. Otherwise, trouble may occur.

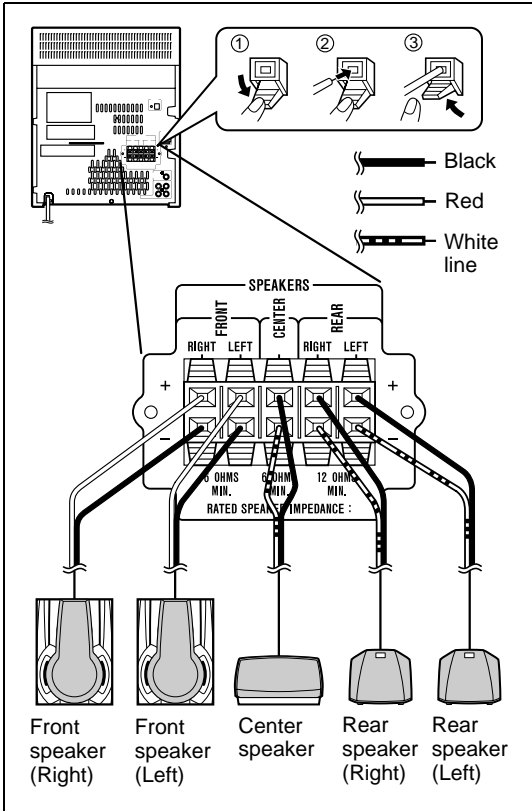

Speaker connection

Connect the speaker wires to the SPEAKER terminals as shown.

Front speakers

- Connect the black wire to the minus (-) terminal, and the red wire to the plus (+) terminal.

Center speaker and rear speakers

- Connect the wire with the white line to the minus (-) terminal and the plain wire to the plus (+) terminal.

Caution:

- Do not mistake the right channel for the left channel when connecting the speakers to the unit.
The right speaker is the one on the right side when you are facing the front of the unit.
- Do not let the bare speaker wires touch each other as this may damage the amplifier and/or speakers.
- Do not allow any objects to fall into or to be placed in the bass reflex ducts.
- Do not stand or sit on the speakers. If the speakers fall or collapse, you may be injured.
- When you use speakers other than the speakers included with this unit, if their impedance is lower than that specified for each speaker type, the unit may be damaged.

Front speakers: 6 ohms
Center speaker: 6 ohms
Rear speakers: 12 ohms

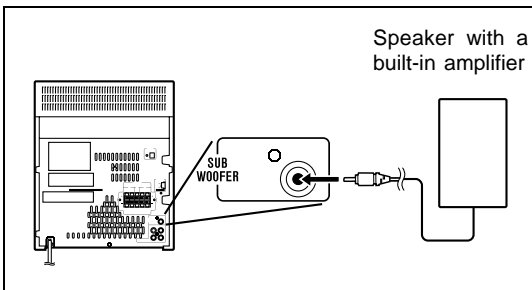

Subwoofer

To enhance the Home Theater experience, you can add a commercially available external subwoofer with a built-in amplifier to this unit.

- Use an RCA cord to connect the external subwoofer with a built-in amplifier to the SUBWOOFER jack on the rear of the unit.

Caution:

- Do not allow any objects to fall into or to be placed in the bass reflex ducts.
- Do not stand or sit on the speakers. If the speakers fall or collapse, you may be injured.

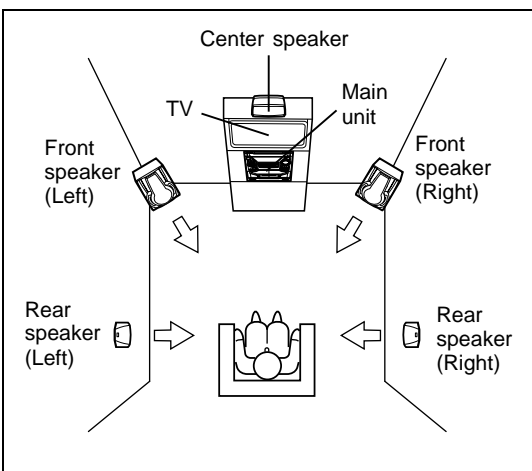

Placing the speaker system

To get the most out of your surround sound speaker system, position them as shown in the illustration.

The front speakers and the center speaker are magnetically shielded to prevent interference to your TV picture. Therefore, they do not affect the display even if you use them near the TV.

However, some color variation may occur, depending on the type of the TV used.

If color variations occur...

Turn off the TV (from the power switch).
After 15-30 minutes, turn the TV on again.

If the color variation is still present...

Move the speakers further away from the TV.

Note:

- If any kind of magnet or an electromagnet is placed too close to the TV monitor and the system, irregular colors may appear on the TV monitor screen.

(Continued)

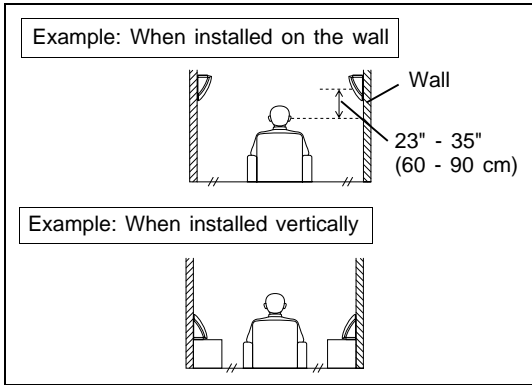

Installation of the rear speakers:

If possible, mount the rear speakers on the wall. Install them 23" - 35" (60 - 90 cm) above the height of your ears when seated, if possible.

To mount the rear speakers on the wall

The design of the rear speakers allows them to be hung on the wall. Be sure to use the type and size screw that is shown to the left.

- 1 Drive one screw into the wall for each speaker as shown in the illustration.
 - Make sure that both the screw and the wall can support a load of 45 lbs. (20 kg).
 - Drive the screws, so there is about a 3/16" (4 mm) space between the wall and the head of the screw.
- 2 Mount the rear speaker on the wall so that the screw head is inserted into the slot on the rear speaker.

Note:

When the rear speakers are installed vertically, the speaker badge will be upside down.

In this case, you can adjust the badge to face the proper direction. Just turn it by hand.

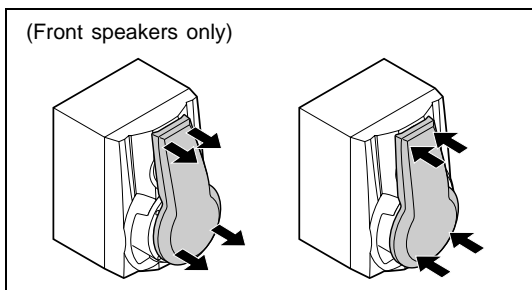
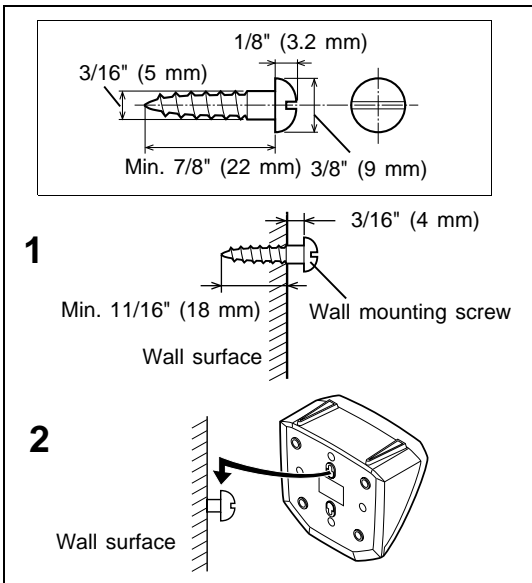
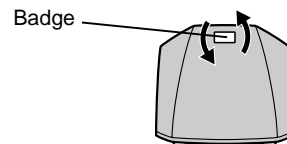

Removing the speaker grilles

- 1 Remove the lower part of the speaker grille first.
- 2 Remove the upper part of the speaker grille.
 - The speaker grilles on the center and rear speakers are not removable.

Caution:

When the speaker grilles are removed, the speaker diaphragms are exposed. Make sure nothing comes into contact with the speaker diaphragms.

Mounting the speaker grilles

Fit the four posts on the speaker grille into the mounting holes and push them lightly with the palm of your hand to secure.

Connecting the AC power cord

- After connecting the speakers, plug the AC power cord into a convenient AC outlet.
- Unplug the AC power cord from the AC outlet if the unit will not be in used for a prolonged period of time.

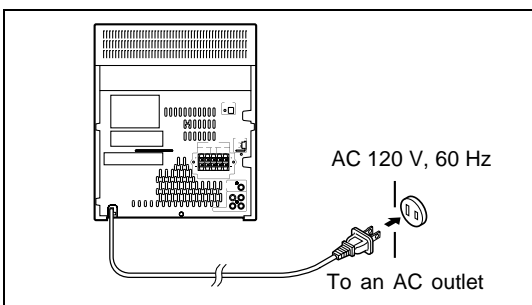

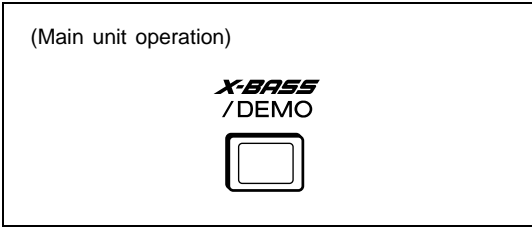

■ Demo mode

When the AC power cord is first connected, the unit will enter the demonstration mode.

To cancel the demonstration mode:

When the unit is in the stand-by mode (demonstration mode), press the X-BASS/DEMO button.

- The demonstration mode will be canceled and the unit will be in the low power consumption mode.

To return to the demonstration mode:

When the unit is in the stand-by mode, press the X-BASS/DEMO button again.

Notes:

- When the unit is in the low power consumption mode, the display will disappear.
- When the power is on, the X-BASS/DEMO button can be used to select the extra bass mode.

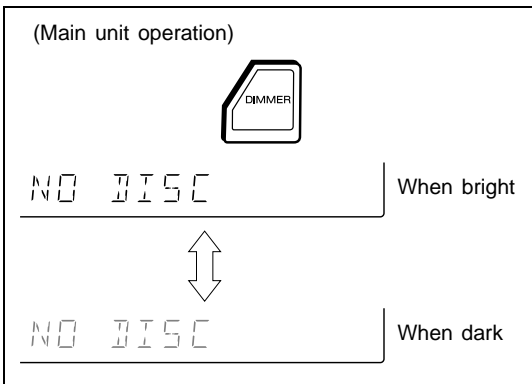

■ To change the brightness of the display

Press the DIMMER button.

- The display will be made dimmer.

To return to the original brightness:

Press the DIMMER button again.

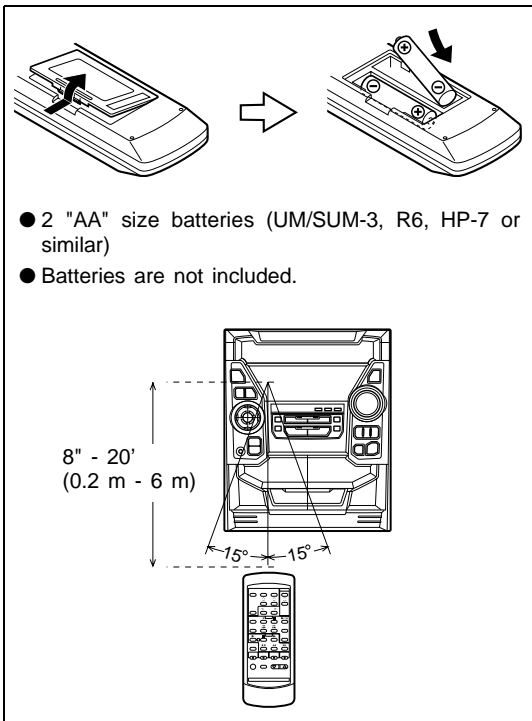

■ Remote control

- When inserting or removing the batteries, push them toward the \ominus battery terminals.
- Installing the batteries incorrectly may cause the unit to malfunction.

Precautions for battery use:

- Insert the batteries according to the direction indicated in the battery compartment.
- Replace all old batteries with new ones at the same time.
- Do not mix old and new batteries.
- Remove the batteries if they are weak or if the unit will not be used for long periods of time. This will prevent potential damage due to battery leakage.

Caution:

Do not use rechargeable batteries (nickel-cadmium battery, etc.).

Notes concerning use:

- Replace the batteries if the operating distance is reduced or if the operation becomes erratic.
- Periodically clean the transmitter LED on the remote control and the sensor on the main unit with a soft cloth.
- Exposing the sensor on the main unit to strong light may interfere with operation. Change the lighting or the direction of the unit.
- Keep the remote control away from moisture, excessive heat, shock, and vibrations.

SOUND CONTROL

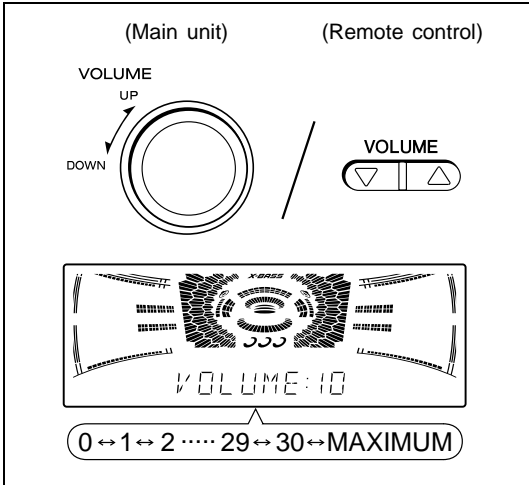

Volume

(Main unit operation)

When the VOLUME control is turned clockwise, the volume will increase. When it is turned counterclockwise, the volume will decrease.

(Remote control operation)

Press the VOLUME \blacktriangle button to increase the volume and the VOLUME \blacktriangledown button to decrease the volume.

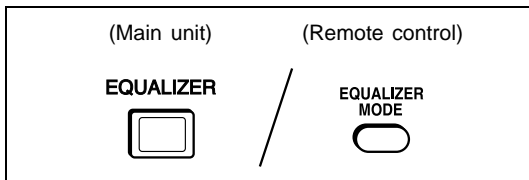

Pre-programmed equalizer

When the EQUALIZER (EQUALIZER MODE) button is pressed, the current mode setting will be displayed. To change to a different mode, press the EQUALIZER (EQUALIZER MODE) button repeatedly.

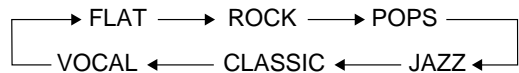

FLAT: The sound is not modified.

ROCK: Bass and treble are emphasized.

POPS: Bass and treble are slightly emphasized.

JAZZ: Treble is cut a little.

CLASSIC: Treble is reduced a lot.

VOCAL: Vocals (midrange tones) are emphasized.

Note:

When the equalizer mode is being used, the Dolby Pro Logic Surround mode is canceled.

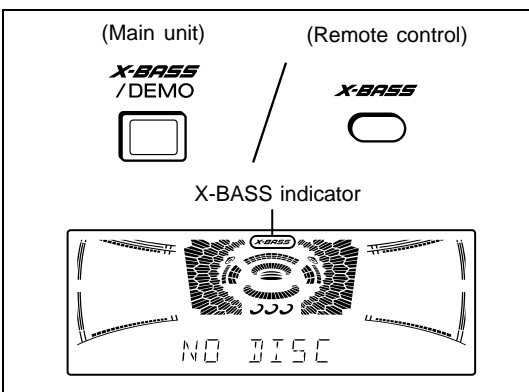

Extra bass (X-BASS)

When the power is first turned on, the unit will enter the extra bass mode which emphasizes the bass frequencies, and "X-BASS" will appear.

To cancel the extra bass mode, press the X-BASS/DEMO (X-BASS) button.

"X-BASS" will go out.

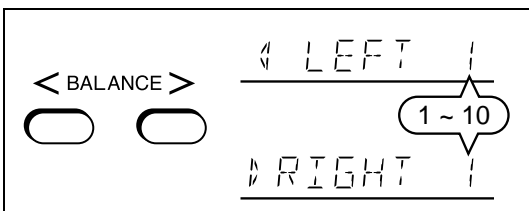

Balance

(Remote control operation)

Press the BALANCE < (LEFT) button to decrease the level of the right speaker, and press the BALANCE > (RIGHT) button to decrease the level of the left speaker.

Dolby Pro Logic Surround mode

Video and DVD software programs carrying the  trademark are recordings that contain the same Dolby Surround data as used in movie theaters.

The Dolby Pro Logic Surround mode uses Dolby Surround data to bring the full presence experienced in a movie theater into your home.

To use this mode, you must connect the rear and center channel speakers.

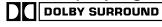
Before playing a video (or DVD) software program carrying the  trademark, be sure to complete the "Dolby Pro Logic Surround setup" as follows.

Dolby Pro Logic Surround setup:

(Remote control operation)

- 1 Press the ON/STAND-BY button to turn the power on.
 - The BYPASS button will light.
- 2 Press the DOLBY PRO LOGIC button to select "NORMAL" or "PHANTOM".
 - Each time you press the button, the display will change as follows:

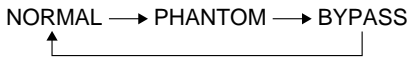

NORMAL: The center speaker is used.

PHANTOM: Use this mode when a center speaker is not connected. The center channel signals are output through the front speakers.

BYPASS: The Dolby Pro Logic Surround mode is canceled.

- The selected Dolby Pro Logic Surround mode is automatically stored in memory and will be used the next time you activate DOLBY PRO LOGIC. This mode is memorized until it is changed.

- 3 Press the TEST TONE button.
 - The test tone is a tone that moves from one speaker to the next, taking 2 seconds to go from speaker to speaker.

In NORMAL mode:

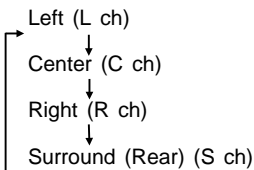

In PHANTOM mode:

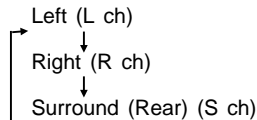

- 4 Adjust the center speaker volume or the volume of the rear speakers.

To adjust the center speaker volume to match the level of the front speakers:

Press the CENTER LEVEL \wedge button to increase the volume and the CENTER LEVEL \vee button to decrease the volume.

- Do this adjustment in the NORMAL mode.

To adjust the volume of the rear speakers to match the level of the front speakers:

Press the SURROUND LEVEL \wedge button to increase the volume and the SURROUND LEVEL \vee button to decrease the volume.

- Do this adjustment in the NORMAL or PHANTOM mode.

- 5 After adjusting the speaker volume, press the TEST TONE button.

- The test tone will stop.

Notes:

- Be sure to adjust the sound from your favorite listening position.
- The volume is adjusted in 1 dB steps up or down each time you press the CENTER LEVEL button or the SURROUND LEVEL button.
- The volume settings for the center and rear speakers are stored in memory for future use. However, if the power is disconnected or there is a power failure, the levels will return to their initial settings.

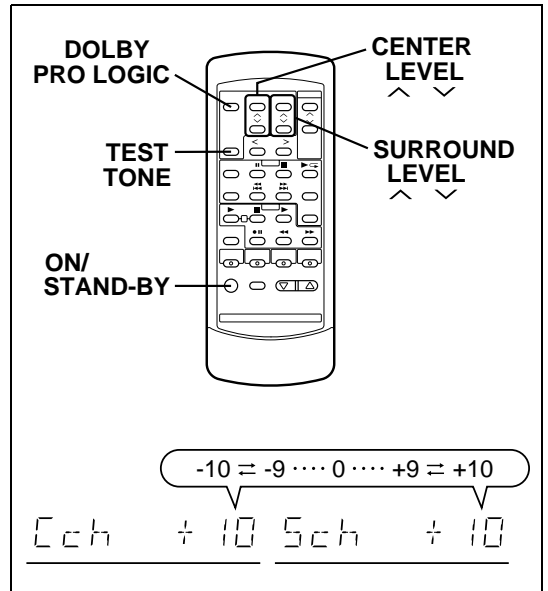
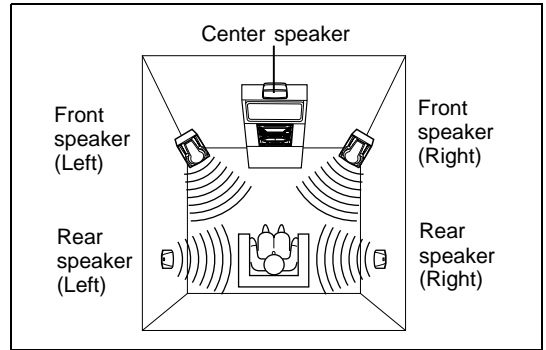

Dolby Pro Logic Surround playback:

- 1 Press the NORMAL or PHANTOM button on the main unit to select the Dolby Pro Logic Surround mode.
 - To select the mode with the remote control, press the DOLBY PRO LOGIC button.
 - Each time you press the button, the display will change as follows:



NORMAL: The center speaker is used.

PHANTOM: Use this mode when a center speaker is not connected.

The center channel signals are output through the front speakers.

BYPASS: The Dolby Pro Logic Surround mode is canceled.

- 2 Play the video software program.
- 3 To cancel the Dolby Pro Logic Surround mode, press the BYPASS button on the main unit or the DOLBY PRO LOGIC button on the remote control until "BYPASS" appears.
 - The BYPASS button will light.

Note:

- You cannot use the Dolby Pro Logic Surround feature with headphones.

SETTING THE CLOCK

(Main unit operation)

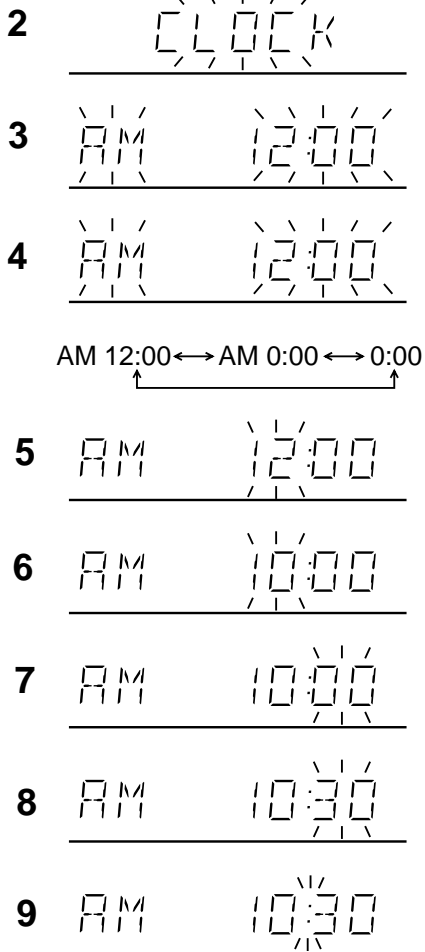
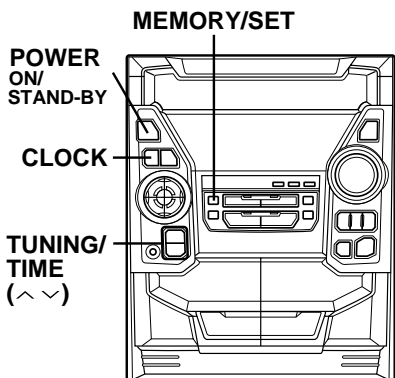

In this example, the clock is set for the 12-hour (AM 12:00) system.

- 1 Press the ON/STAND-BY button to enter the stand-by mode.
- 2 Press the CLOCK button.
- 3 Within 5 seconds, press the MEMORY/SET button.
- 4 Press the TUNING/TIME (∨ or ∧) button to select the time display mode.
 - "AM 12:00" → The 12-hour display will appear. (AM 12:00 - PM 11:59)
 - "AM 0:00" → The 12-hour display will appear. (AM 0:00 - PM 11:59)
 - "0:00" → The 24-hour display will appear. (0:00 - 23:59)

● Note that this can only be set when the unit is first installed or it has been reset (see page 21).

- 5 Press the MEMORY/SET button.
- 6 Press the TUNING/TIME (∨ or ∧) button to adjust the hour.
 - Press the TUNING/TIME (∨ or ∧) button once to advance the time by 1 hour. Hold it down to advance continuously.
 - When the 12-hour display is selected, "AM" will change automatically to "PM".
- 7 Press the MEMORY/SET button.
- 8 Press the TUNING/TIME (∨ or ∧) button to adjust the minutes.
 - Press the TUNING/TIME (∨ or ∧) button once to advance the time by 1 minute. Hold it down to change the time in 5 minute intervals.
 - The hour setting will not advance even if minutes advance from "59" to "00".
- 9 Press the MEMORY/SET button.
 - The clock starts operating from "0" second. (Seconds are not displayed.)
 - And then the clock display will disappear after a few seconds.

To see the time display:

Press the CLOCK button.

- The time display will appear for about 5 seconds.

Note:

- The clock display will flash on and off at the push of the CLOCK button when the AC power supply is restored after a power failure occurs or after the AC power cord is disconnected. If this happens, follow the procedure below to change the clock time.

To change the clock time:

- ① Press the CLOCK button.
- ② Within 5 seconds, press the MEMORY/SET button.
- ③ Perform steps 6 - 9 above.

To change the time display mode:

- ① Perform steps 1 - 2 in the section "RESETTING THE MICROCOMPUTER", on page 21.
- ② Perform steps 1 - 9 above.

COMPACT DISC OPERATION

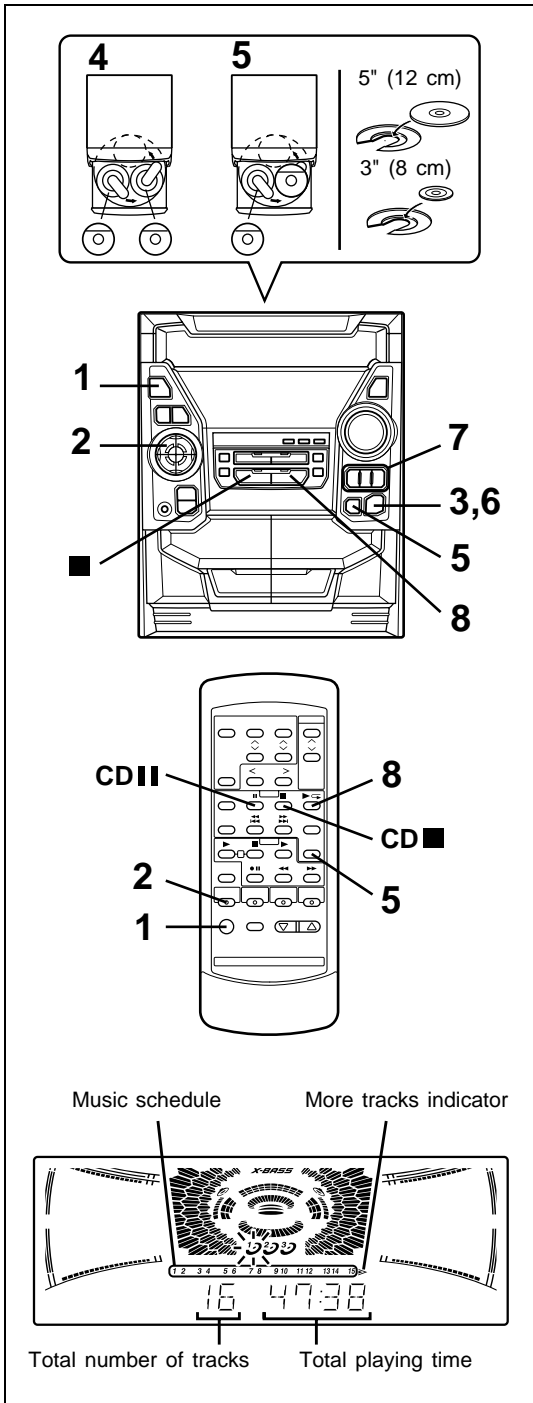

■ CD playback

- 1 Press the ON/STAND-BY button to turn the power on.
- 2 Press the CD button.
- 3 Press the OPEN/CLOSE button to open the disc tray.
- 4 Place the CD(s) on the disc tray, label side up.
 - CDs can be placed on any open position on the disc tray.
 - Be sure to place 3" (8 cm) CD(s) in the middle of the disc trays.

Caution:

Do not stack CDs in the tray.
This can damage the player and the CDs.

- 5 When loading a third disc, press the DISC SKIP button to turn the disc tray, then place the CD in the open position.
- 6 Press the OPEN/CLOSE button to close the disc tray.
 - The total number of tracks and the total playing time for one disc will be displayed. At this time, the disc number indicator is flashing.
 - The music schedule will be displayed only for the number of tracks on the disc.
 - If the CD contains more than 15 tracks, "▶" will appear.
- 7 Press the desired disc number button (1 - 3).

- 8 Press the ▶/◀ (▶◀) button.

- Playback will begin from track 1 on the disc you have selected to play.
- After the disc finishes playing, the next disc will automatically play.
- When there is no CD in one of the disc 1 - 3 positions, that position will be skipped and the next CD will be played.
- When the last track on the third disc has finished playing, the unit will stop automatically.

To interrupt playback:

- ① Press the CD II button on the remote control.
 - "II" will appear.
- ② Press the ▶◀ button to resume playback from the same point.

To stop playback:

Press the ■ (CD ■) button.

To remove the CDs:

While in the stop mode, press the OPEN/CLOSE button.
● The disc tray will open. Remove the two discs. Then, press the DISC SKIP button to rotate the disc tray and remove the remaining disc.

After use:

Press the ON/STAND-BY button to enter the stand-by mode.

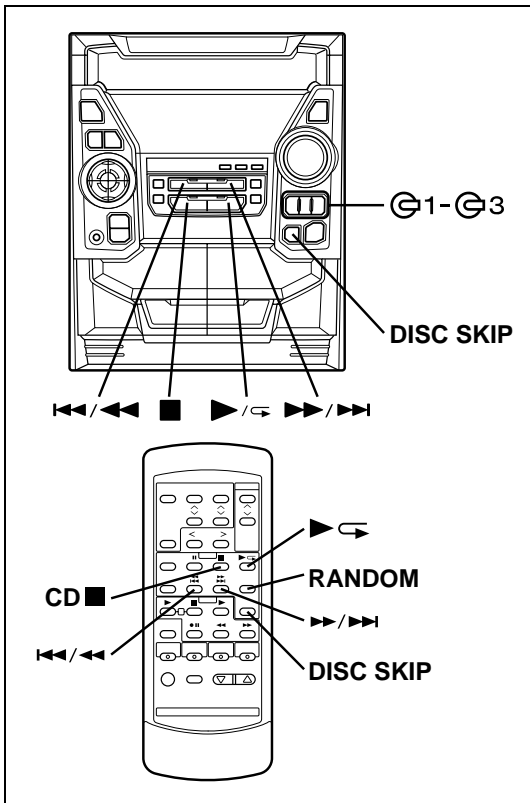

Caution:

● Do not carry the unit with discs left in the disc trays. The discs may come loose inside the unit and they may be damaged or cause damage to the unit. This may also cause malfunctions.

- Do not place two CDs in one disc position.
- Do not push the disc tray while it is moving.
- Do not attempt to turn the disc tray by hand. This may cause malfunctions.
- If the power fails while the tray is open, wait until the power is restored.
- If the disc tray is stopped forcibly, "ERR" will appear in the display and the unit will not function. If this occurs, press the ON/STAND-BY button to enter the stand-by mode and then turn the power on again.
- If TV or radio interference occurs during CD operation, move the unit away from the TV or radio.
- If a disc is damaged, dirty, or loaded upside down, the disc will be skipped and the next disc will automatically play.

Disc number selection

- 1 When stopped, press the DISC SKIP button.
- 2 Press the ►/◄ (▶◄) button.
 - The next disc playback will begin, after which each following disc will be played sequentially.

Notes:

- When the DISC SKIP button is pressed during playback, playback will begin automatically from the next disc. (It is not necessary to press the ►/◄ (▶◄) button.)
- When one of the disc number buttons (Ⓢ 1-Ⓢ 3) is pressed during playback, playback of the selected disc will begin automatically. (It is not necessary to press the ►/◄ (▶◄) button.)

APSS (Auto Program Search System)

APSS automatically locates the beginning of any track.

To listen again to the track being played:

Press the ◀◀ button for less than 0.5 seconds during playback.

To move to the beginning of the next track:

Press the ▶▶ button for less than 0.5 seconds during playback.

- To skip a number of tracks at one time, press the ◀◀ or ▶▶ button repeatedly until the desired track number is shown.
- To start playing at a desired track, press the ◀◀ or ▶▶ button while in the stop mode to select the track number, and then press the ►/◄ (▶◄) button.

Note:

- APSS can only search for music on a single disc.

Cue and review

- 1 Load a disc and begin playback.
- 2 Hold down the ▶▶ button for audible fast forward, and hold down the ◀◀ button for audible fast reverse.
- 3 Normal playback will resume when the ◀◀ or ▶▶ button is released.

Notes:

- When the end of the disc is reached while cueing, "END" will appear in the display and CD operation will be paused. (Even though the next disc has been loaded, the disc will not be switched.) Press the ◀◀ button for fast reverse or press the ■ (CD ■) button to stop CD operation.
- If the beginning of the disc is reached while reviewing, the mode will automatically switch to normal playback at that point.

Random play

(Remote control operation)

The tracks on the disc(s) can be played in random order automatically.

- 1 Load a disc(s) and close the disc tray.
- 2 Press the RANDOM button to begin random play.
 - "R" will appear.

Notes:

- When using random play, be sure to press the ■ (CD ■) button after you are through listening. Otherwise, the disc(s) will play continuously.
- In random play the unit will select and play tracks automatically. (You cannot select the order of the tracks.)

To cancel random play:

- Press the ►/◄ (▶◄) button.
- "R" will go out.

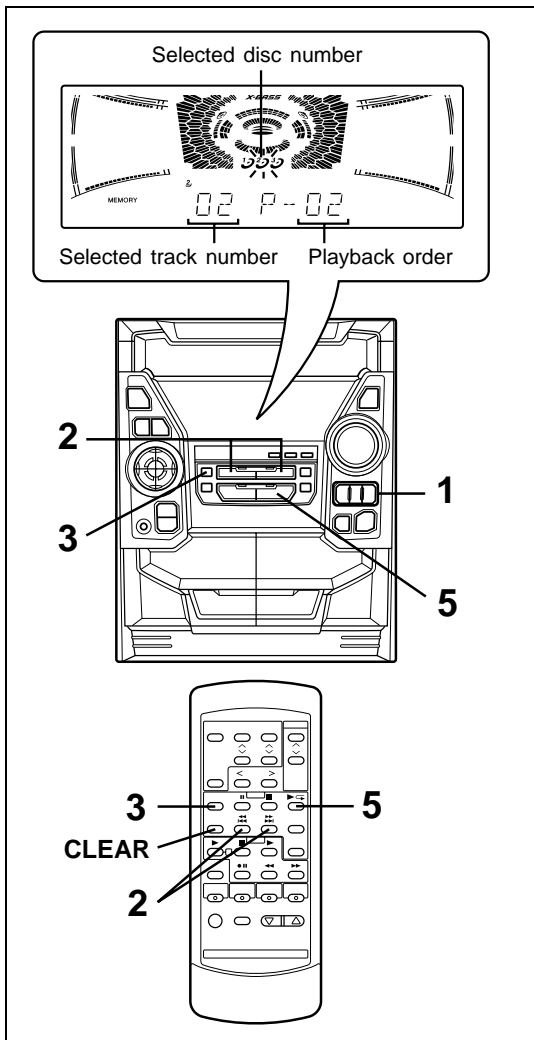

■ APMS

(Automatic Programmable Music Selector)

You can playback the tracks on the CDs in the disc 1 - 3 positions in any order desired. By specifying the disc numbers from 1 to 3, and the track numbers from 1 to 99, you can choose up to 32 selections for playback in the order you like.

- 1 When in the stop mode, use the disc number buttons (⊖ 1 - ⊕ 3) to select the desired disc number.
- 2 Press the ◀◀ or ▶▶ button to select the desired track.
- 3 Press the MEMORY/SET (MEMORY) button.
 - "MEMORY" will appear to show that the programmed sequence is being entered into memory.
- 4 Repeat steps 1 - 3 for any other track. Up to 32 tracks can be programmed.
 - If you make a mistake while in the programming mode ("MEMORY" will appear) or if you wish to change your selections, the programmed tracks can be cleared by pressing the CLEAR button. The tracks will be cleared sequentially, starting with the last track entered.
- 5 Press the ▶/◀ (▶◀) button to start playback of programmed selections.

To clear the programmed selections:

Press the CLEAR button on the remote control while the disc is stopped.

- Each time the button is pressed, one track will be cleared, beginning with the last track programmed.

Notes:

- Opening the disc tray automatically cancels the programmed sequence.
- Even if you press the ON/STAND-BY button to enter the stand-by mode or the function is changed from CD to some other function, the programmed selections will not be cleared.
- During APMS operation, random play is not possible.

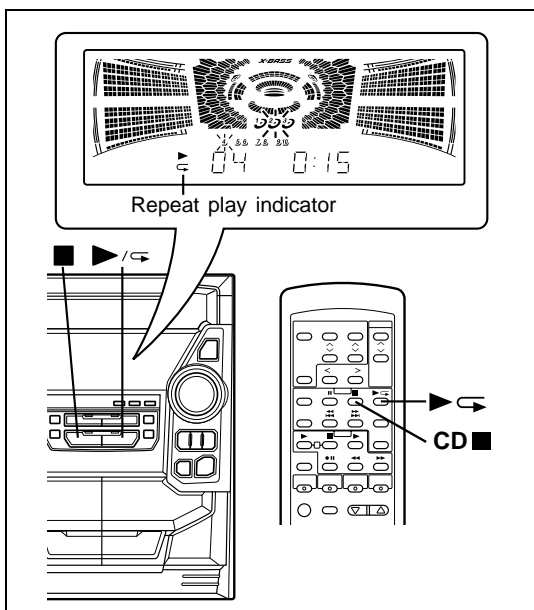

■ Repeat play

All tracks on up to 3 discs, or a programmed sequence can be continuously repeated.

To repeat all tracks on up to 3 discs:

Press the ▶/◀ (▶◀) button twice.

- "◀" will appear.

To repeat a programmed sequence:

- 1 Program a sequence of up to 32 tracks.

- 2 Press the ▶/◀ (▶◀) button twice.

- "◀" will appear.

To cancel repeat play:

Press the ▶/◀ (▶◀) button again.

- "◀" will go out.

Note:

- When using repeat play, be sure to press the ■ (CD ■) button after you are through listening. Otherwise, the CD(s) will play continuously.

(Main unit operation)

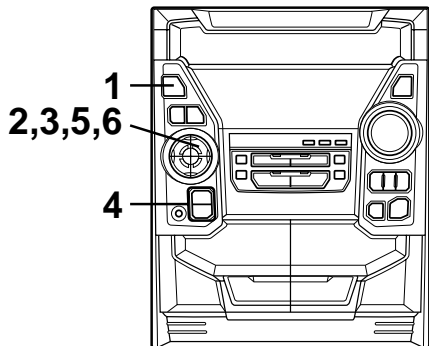

■ Tuning

- 1 Press the ON/STAND-BY button to turn the power on.
- 2 Press the TUNER (BAND) button.
- 3 Press the TUNER (BAND) button to select the desired frequency band. (FM ST, FM or AM)
- 4 Press the TUNING/TIME (✓ or ^) button to tune into the desired station.

Manual tuning:

Press the TUNING/TIME (✓ or ^) button as many times as required to adjust the frequency shown on the display to the frequency of the desired station.

Auto tuning:

When the TUNING/TIME (✓ or ^) button is pressed for more than 0.5 seconds, scanning will start automatically and the tuner will stop at the first receivable broadcast station.

Notes:

- When radio interference occurs during auto scan tuning, auto scan tuning may stop automatically at that point.
 - If a weak station signal is found during auto scan tuning, the station will be skipped.
 - To stop the auto tuning, press the TUNING/TIME (✓ or ^) button again.
- 5 To receive an FM stereo transmission, press the TUNER (BAND) button so that the "ST" indicator on the display lights up.
 - "∞" will appear when an FM broadcast is in stereo.
 - 6 If the FM reception is weak, press the TUNER (BAND) button so that the "ST" indicator goes out.
 - The reception changes to monaural, and the sound becomes clearer.

After use:

Press the ON/STAND-BY button to enter the stand-by mode.

Note:

- The last station tuned in will be recalled, even after changing the tuning band or the function, or after switching the unit to the stand-by mode.

■ Preset tuning

You can store up to 40 stations in memory (40 stations consisting of any combination of FM and AM stations you like) and recall them at the push of a button.

To enter stations into memory:

- 1 Perform steps 1 - 6 in the "Tuning" section.
- 2 Press the MEMORY/SET button.
 - "MEMORY" and the preset channel number will flash.
- 3 Within 30 seconds, press the PRESET (✓ or ^) button to make the preset channel number flash in the display.
 - Store the stations in memory, in order, starting with preset channel 1.
- 4 Within 30 seconds, press the MEMORY/SET button to store that station in the selected station preset number memory.
 - If the "MEMORY" and preset number indicators go out before the station is memorized, repeat the operation from step 2.
- 5 Repeat steps 1 - 4 to set other preset stations, or to change a preset station.
 - When a new station is stored in the selected station preset number memory, the contents previously memorized will be erased.

(Main unit operation)

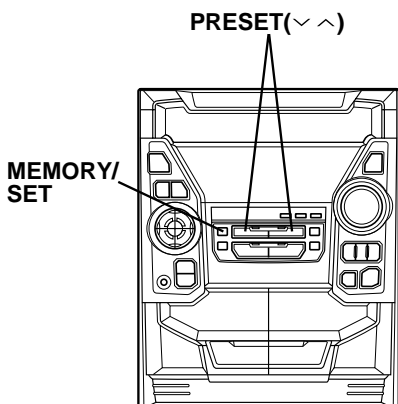

(Continued)

To recall a memorized station:

Press the PRESET (∨ or ∧) button for less than 0.5 seconds to select the desired station.

- The stations (preset channel number, frequency and frequency band) which have been stored in memory will appear in the display in numerical order, irrespective of the frequency bands.

Note:

When searching for a memorized station, do not press the PRESET button for more than 0.5 seconds.

When the PRESET button is pressed for more than 0.5 seconds, the unit will enter the preset memory scan mode.

Backup function:

The backup function protects all station presets for a few hours should there be a power failure or the AC power cord is removed from the AC outlet.

■ Preset memory scan

The stations saved in the preset memory can be scanned automatically.

- 1 To scan the preset stations, press the PRESET (∨ or ∧) button for more than 0.5 seconds.

- The station preset number will flash and the programmed stations will be tuned in sequentially, for 5 seconds each.

- 2 Press the PRESET (∨ or ∧) button again to stop the memory scan at the desired station.

Note:

When the preset memory does not have any stations stored in it, the preset memory scan will not function.

To erase all the contents in the preset memory:

- 1 Press the ON/STAND-BY button to enter the stand-by mode.

- 2 Press the ON/STAND-BY button while holding down the TUNER (BAND) button and the X-BASS/DEMO button.

- "TUNER CL" will appear.

- After performing this operation, all of the preset memory information will be erased.

CASSETTE OPERATION

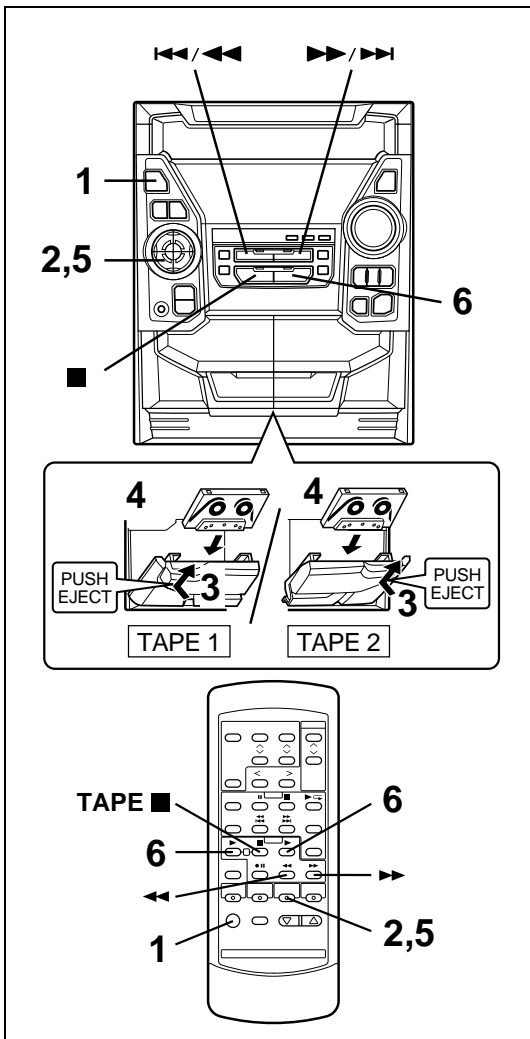

■ TAPE 1 or TAPE 2 playback

- 1 Press the ON/STAND-BY button to turn the power on.

- 2 Press the TAPE (1 ↔ 2) button.

- 3 Open the cassette door by pushing the area marked "PUSH EJECT".

- 4 Load the cassette into the TAPE 1 or TAPE 2 cassette compartment.

- 5 With cassettes in both decks, press the TAPE (1 ↔ 2) button to switch operation from one deck to the other.

- 6 Press the ▶/◀ button to start playback.

- When playback is performed using the remote control, press the TAPE 1 or TAPE 2 ▶ button.

To stop playback:

Press the ■ (TAPE ■) button.

Fast forward/rewind: (TAPE 2 only)

- ① Press the ■ (TAPE ■) button, then press the TAPE (1 ↔ 2) button to select TAPE 2.

- ② To advance the tape, press the ▶▶ button.
To rewind it, press the ◀◀ button.

Caution:

- To remove the cassette tape, press the ■ (TAPE ■) button, and then open the cassette compartment.

- Before changing from one tape operation to another, press the ■ (TAPE ■) button.

- If a power failure occurs during tape operation, the tape head will remain engaged with the tape and the cassette door will not open. In this case, wait until power is restored.

RECORDING

- When recording important selections, be sure to make a preliminary test to ensure that the desired material is being properly recorded.
- The volume and sound quality can be adjusted with no effect on the recorded signal. (Variable Sound Monitor)

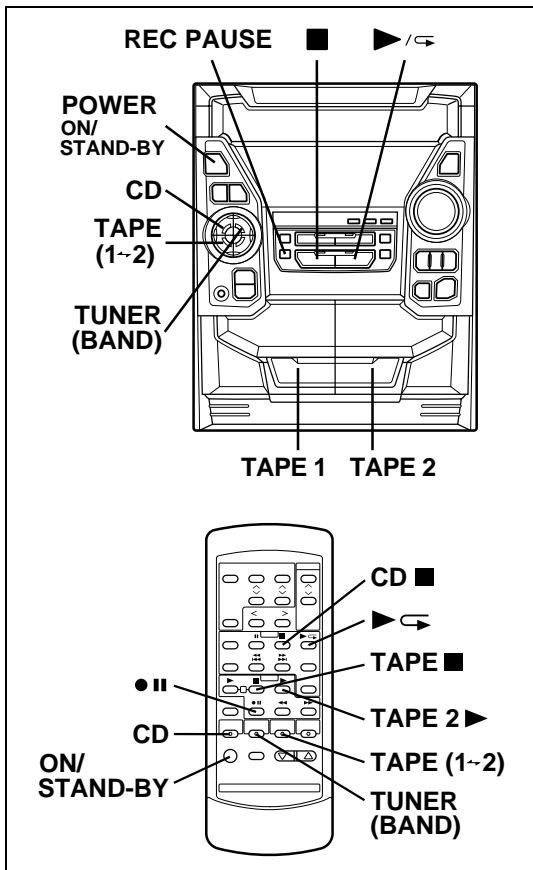

Recording from the built-in radio

- 1 Tune in to the desired station. (See pages 16-17.)
- 2 Load a cassette into the TAPE 2 cassette compartment.
- 3 Press the REC PAUSE (● ||) button.
 - "REC" will flash.
- 4 Press the ▶/◀ (TAPE 2 ▶) button.
 - "REC" will appear.

Note:

- If a whistling noise is heard while recording from an AM station, move the AM loop antenna to a position where noise is no longer heard from the unit.

To stop recording:

Press the ■ (TAPE ■) button.

- Metal and CrO₂ tapes should not be used for recording or dubbing.

Recording from the built-in CD player (CD Synchronized Recording System)

- 1 Press the ON/STAND-BY button to turn the power on.
- 2 Press the CD button and load the desired disc.
 - Use the APMS function to store the tracks you want to record in memory. (See page 15.)
- 3 Load a cassette into the TAPE 2 cassette compartment.
- 4 Press the REC PAUSE (● ||) button.
 - "SYNC" and "REC" will flash.
- 5 Press the ▶/◀ (TAPE 2 ▶) button.
 - "SYNC" will disappear and "REC" will light up.
 - CD playback will start approximately 5 seconds after the tape starts.

To stop recording:

Press the ■ (CD ■) button.
The CD and tape will stop.

Note:

- When the end of the tape is reached while recording, the CD player will display the track number which was being played at that time, and stop automatically.
If you want to restart recording from the beginning of the interrupted track, turn over the tape, press the REC PAUSE (● ||) button and then the ▶/◀ (TAPE 2 ▶) button. (If tracks have been stored in memory using the APMS function, recording will restart from the first track stored in memory.)

Dubbing from tape to tape

- 1 Press the ON/STAND-BY button to turn the power on.
- 2 Load a prerecorded cassette into the TAPE 1 cassette compartment. Insert a blank tape into the TAPE 2 cassette compartment.
 - It is recommended that the recording tape be the same length as the master tape.
- 3 Press the TAPE (1 ↔ 2) button until "TAPE 1" appears in the display.
- 4 Press the REC PAUSE (● ||) button.
- 5 Press the ▶/◀ (TAPE 2 ▶) button.

To stop dubbing:

Press the ■ (TAPE ■) button.

- TAPE 1 and TAPE 2 will simultaneously stop.

Erasing recorded tapes

- Make sure that TAPE 1 is not in use.
- 1 Load the tape to be erased into the TAPE 2 cassette compartment.
 - 2 Press the TAPE (1 ↔ 2) button until "TAPE 2" appears in the display.
 - 3 Press the REC PAUSE (● ||) button.
 - 4 Press the ▶/◀ (TAPE 2 ▶) button.

HOW TO USE THE BUILT-IN TIMER

- Before setting the timer, make sure that the clock setting is correct. (Page 12)

(Main unit operation)

3 AM 12:00

4 AM 8:00

AM 8:00

5 AM 8:30

(Main unit operation)

3 AM 12:00

4 AM 8:00

AM 8:00

5 AM 8:30

■ Timer playback

- 1 Press the ON/STAND-BY button to turn the power on.
- 2 Press the CD, TUNER (BAND), TAPE (1 → 2) or VIDEO/AUX button to select the desired function.
- 3 Press the TIMER/SLEEP button repeatedly until "⊕ PLAY" is displayed.
 - The timer set indicator will flash.
- 4 Press the TUNING/TIME (∨ or ∧) button to set the hour start time, then press the MEMORY/SET button.
- 5 Press the TUNING/TIME (∨ or ∧) button to set the minute start time, then press the MEMORY/SET button.
 - The power will be automatically turned off, then the timer set indicator will light up and finally the "⊕ PLAY" will be disappeared.
- 6 When the preset time is reached, the volume will increase gradually until it reaches the volume you were listening to before turning off the unit.
- 7 If you select CD or TAPE, the power will be turned off after the tape or CD is finished playing back. If you select TUNER or VIDEO/AUX, the power will be turned off one hour later.

Note:

- When performing timer playback using an external unit connected to the VIDEO/AUX jacks, only the power of the main unit will be turned off automatically. (The power of the external unit will not be turned off.)

■ Timer recording

- 1 Press the ON/STAND-BY button to turn the power on.
 - Load a cassette for recording into the TAPE 2 cassette compartment.
- 2 Press the TUNER (BAND) or VIDEO/AUX button to select the desired function.
- 3 Press the TIMER/SLEEP button repeatedly until "⊕ REC" is displayed.
 - The timer set indicator will flash.
- 4 Press the TUNING/TIME (∨ or ∧) button to set the hour start time, then press the MEMORY/SET button.
- 5 Press the TUNING/TIME (∨ or ∧) button to set the minute start time, then press the MEMORY/SET button.
 - The power will be automatically turned off, and the timer set indicator will light up.
- 6 When the preset time is reached, the timer recording will start.
 - The volume will increase gradually until it reaches the volume you were listening to before turning off the unit.
- 7 When the recording tape reaches its end, the timer recording will end, and the power will be turned off.

To cancel timer operation:

Press the ON/STAND-BY button to turn the power on.

To change the programmed contents:

Start again from step 1.

Note:

- Once the time is set, the setting will be retained until a new time is entered.

(Continued)

(Main unit operation)

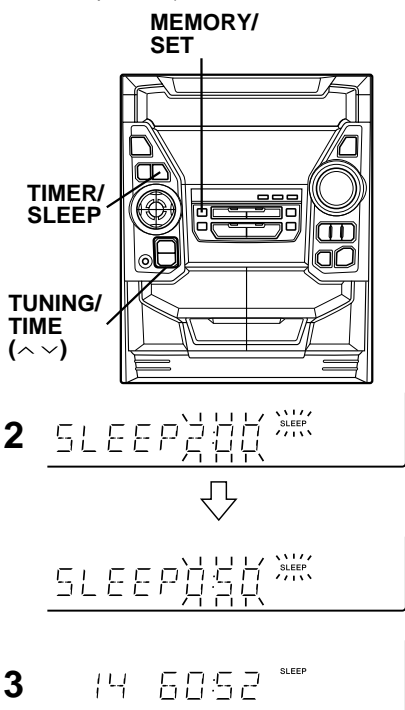

■ Sleep operation

The radio, compact disc and cassette deck can all be turned off automatically.

- 1 Play back the desired sound source.
- 2 Press the TIMER/SLEEP button repeatedly until "SLEEP" is displayed.

To change the sleep time:

While the sleep time is displayed, press the TUNING/TIME (v or ^) button to adjust the time.

(Maximum: 3 hours - Minimum: 1 minute)

The amount of sleep time can also be changed during the sleep operation.

- 3 hours - 5 minutes → 5-minute intervals
- 5 minutes - 1 minute → 1-minute intervals

- 3 Press the MEMORY/SET button.

- 4 The unit will turn off automatically after the preset sleep time has elapsed.

Note:

- Once the sleep time is set, it will remain the same duration until the setting is changed.

To confirm the remaining sleep time:

Press the TIMER/SLEEP button.

To cancel the sleep operation:

Press the ON/STAND-BY button to enter the stand-by mode.

USING EXTERNAL UNITS

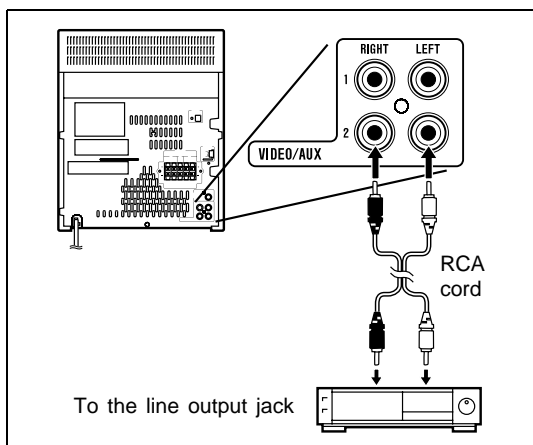

■ Video/Auxiliary (Audio signal) input

To listen to or record signals from external sources through this unit:

- 1 Use an RCA cord to connect the desired external unit to the VIDEO/AUX 1 or 2 jacks.
(red → right channel, white → left channel)
- When using video equipment (video disc player or VCR), be sure to connect the audio output to this unit and the video output to a television.
- 2 Press the ON/STAND-BY button to turn the power on.
- 3 Press the VIDEO/AUX button.
 - Select either "VIDEO 1" or "VIDEO 2".
- 4 Operate the external unit.
- 5 To record the sound from the external unit, perform steps 2 - 4 of the "Recording from the built-in radio" section on page 18.

Note:

- To prevent hum interference, do not place this unit near a television receiver.

■ CD digital output (optical)

The CD digital signal from this unit can be recorded by other DAT or MiniDisc recorders.

- 1 Remove the CD DIGITAL OUT jack cover.
- 2 Use a commercially available digital cable to connect the unit to the OPTICAL IN jack of a MiniDisc recorder or a DAT.
- 3 Put the external unit in the recording mode.
- 4 Play a CD on this unit.

Note:

- Only CD signals can be output.

(Continued)

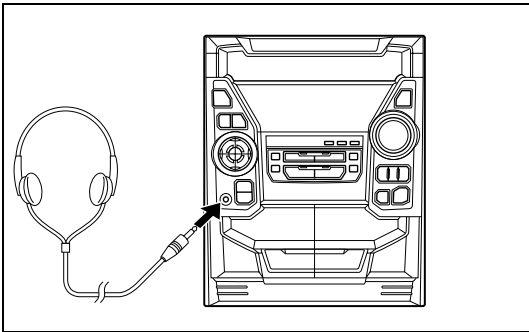

■ Headphones

- Before plugging in or unplugging the headphones, make sure the volume level is reduced.
- Be sure your headphones have a 1/8" (3.5 mm) diameter plug and are between 16 ohms and 50 ohms impedance. The recommended impedance is 32 ohms.
- When headphones are connected, the speakers are disconnected automatically. Adjust the VOLUME control for the desired volume.

Note:

- You cannot use the Dolby Pro Logic Surround feature with headphones.

RESETTING THE MICROCOMPUTER

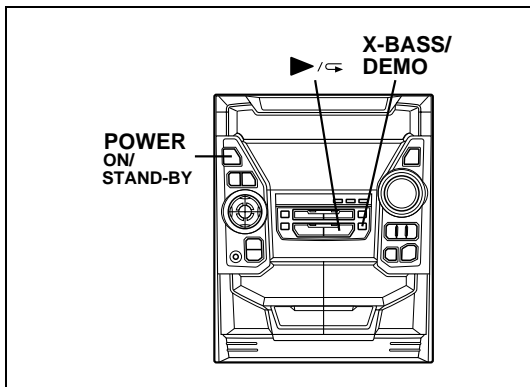

Reset the microcomputer under the following conditions:

- To erase all of the stored memory contents (clock and timer settings, and tuner and CD presets).
- If the display is not correct.
- If the operation is not correct.

1 Press the ON/STAND-BY button to enter the stand-by mode.

2 While pressing down the play/pause button and the X-BASS/DEMO button, hold down the ON/STAND-BY button for at least 1 second.

- "CLEAR AL" will appear.

Caution:

- The operation explained above will erase all data stored in memory including clock and timer settings, and tuner and CD presets.

MAINTENANCE

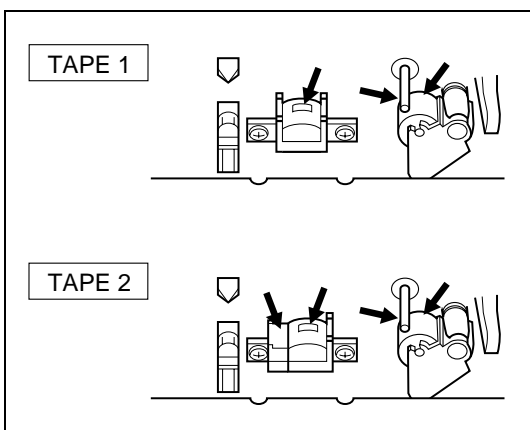

■ Internal care

- Dirty heads, capstans or pinch rollers can cause poor sound and tape jams. Clean these parts with a cotton swab moistened with commercial head/pinch roller cleaner or isopropyl alcohol.
- After long use, the deck's heads and capstans may become magnetized, causing poor sound. Demagnetize these parts once every 30 hours of playing/recording time by using a commercial tape head demagnetizer. Read the demagnetizer's instructions carefully before use.
- In order to ensure proper operation of the CD player, preventative maintenance (cleaning of the Laser Pick-up lens) should be performed periodically in order to keep the lens dust-free. Lens cleaners are commercially available. Contact your local CD software dealer for options.

■ External care

- Periodically wipe the cabinet with a soft cloth and a diluted soap solution, then wipe with a dry cloth.
- Do not use chemically treated cleaning cloths or other chemicals.

TRANSPORTING THE UNIT

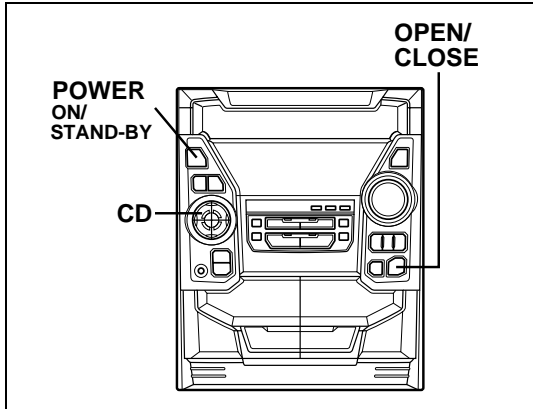

Before you move this product to a new location, proceed as follows:

- 1 Press the ON/STAND-BY button to turn the power on.
- 2 Press the CD button.
- 3 Press the OPEN/CLOSE button to open the disc tray.
 - Remove all CDs inserted in the unit.
- 4 Press the OPEN/CLOSE button to close the disc tray.
 - Make sure that "NO DISC" is displayed.
- 5 Press the ON/STAND-BY button to enter the stand-by mode, and then unplug the AC power cord from the AC outlet.

SPECIFICATIONS

As part of our policy of continuous improvement, SHARP reserves the right to make design and specification changes for product improvement without prior notice. The performance specification figures indicated are nominal values of production units. There may be some deviations from these values in individual units.

● General

Power source:	AC 120 V, 60 Hz
Power consumption:	150 W
Dimensions:	Width; 10-5/8" (270 mm) Height; 13" (330 mm) Depth; 14" (355 mm)
Weight:	18.2 lbs. (8.3 kg)

● Amplifier section

Output power:	Front speakers; 60 W minimum RMS into 6 ohms from 60 Hz to 20 kHz with no more than 10 % total harmonic distortion. Center speaker; RMS; 30 W (1 kHz, 10 % T.H.D.) Rear speakers; RMS; 30 W (total) (1 kHz, 10 % T.H.D.)
Output terminals:	Front speakers; 6 ohms Center speaker; 6 ohms Rear speakers; 12 ohms Subwoofer; 47 k ohms Headphones; 16-50 ohms (recommended; 32 ohms) CD digital output (optical)
Input terminals:	Video/Auxiliary (audio signal) × 2; 500 mV/47 k ohms

● Compact disc player section

Type:	3-disc multi-play compact disc player
Signal readout:	Non-contact, 3-beam semi-conductor laser pickup
D/A converter:	1-bit D/A converter
Frequency response:	20 - 20,000 Hz
Dynamic range:	90 dB (1 kHz)

● Tuner section

Frequency range:	FM; 87.5-108 MHz AM; 530-1,720 kHz
-------------------------	---------------------------------------

● Cassette deck section

Frequency response:	50-14,000 Hz (Normal tape)
Signal/noise ratio:	55 dB (TAPE 1, playback) 50 dB (TAPE 2, recording/playback)
Wow and flutter:	0.3 % (WRMS)

● Front speaker section

Type:	3-way type [5-1/4" (13 cm) woofer, 2" (5 cm) tweeter and super tweeter]
Maximum input power:	120 W
Rated input power:	60 W
Impedance:	6 ohms
Dimensions:	Width; 9-1/2" (240 mm) Height; 13" (330 mm) Depth; 10-1/16" (255 mm)
Weight:	8.5 lbs. (3.9 kg)/each

● Center speaker section

Type:	4" (10 cm) full-range speaker
Maximum input power:	60 W
Rated input power:	30 W
Impedance:	6 ohms
Dimensions:	Width; 10-1/4" (260 mm) Height; 5-1/2" (140 mm) Depth; 6-1/8" (155 mm)
Weight:	2.0 lbs. (0.9 kg)

● Rear speaker section

Type:	4" (10 cm) full-range speaker
Maximum input power:	30 W
Rated input power:	15 W
Impedance:	12 ohms
Dimensions:	Width; 7-7/8" (200 mm) Height; 3-11/16" (93 mm) Depth; 6-3/4" (170 mm)
Weight:	1.1 lbs. (0.5 kg)/each

CONSUMER LIMITED WARRANTY

SHARP ELECTRONICS CORPORATION warrants to the first consumer purchaser that this Sharp brand product (the "Product"), when shipped in its original container, will be free from defective workmanship and materials, and agrees that it will, at its option, either repair the defect or replace the defective Product or part thereof with a new or remanufactured equivalent at no charge to the purchaser for parts or labor for the period(s) set forth below.

This warranty does not apply to any appearance items of the Product nor to the additional excluded item(s) set forth below nor to any Product the exterior of which has been damaged or defaced, which has been subjected to improper voltage or other misuse, abnormal service or handling, or which has been altered or modified in design or construction.

In order to enforce the rights under this limited warranty, the purchaser should follow the steps set forth below and provide proof of purchase to the servicer.

The limited warranty described herein is in addition to whatever implied warranties may be granted to purchasers by law. ALL IMPLIED WARRANTIES INCLUDING THE WARRANTIES OF MERCHANTABILITY AND FITNESS FOR USE ARE LIMITED TO THE PERIOD(S) FROM THE DATE OF PURCHASE SET FORTH BELOW. Some states do not allow limitations on how long an implied warranty lasts, so the above limitation may not apply to you.

Neither the sales personnel of the seller nor any other person is authorized to make any warranties other than those described herein, or to extend the duration of any warranties beyond the time period described herein on behalf of Sharp.

The warranties described herein shall be the sole and exclusive warranties granted by Sharp and shall be the sole and exclusive remedy available to the purchaser. Correction of defects, in the manner and for the period of time described herein, shall constitute complete fulfillment of all liabilities and responsibilities of Sharp to the purchaser with respect to the Product, and shall constitute full satisfaction of all claims, whether based on contract, negligence, strict liability or otherwise. In no event shall Sharp be liable, or in any way responsible, for any damages or defects in the Product which were caused by repairs or attempted repairs performed by anyone other than an authorized servicer. Nor shall Sharp be liable or in any way responsible for any incidental or consequential economic or property damage. Some states do not allow the exclusion of incidental or consequential damages, so the above exclusion may not apply to you.

THIS WARRANTY GIVES YOU SPECIFIC LEGAL RIGHTS. YOU MAY ALSO HAVE OTHER RIGHTS WHICH VARY FROM STATE TO STATE.

Model Specific Section

Your Product Model Number & Description: CD-PC3500 Mini Component System
(Be sure to have this information available when you need service for your Product.)

Warranty Period for this Product: One (1) year parts and labor from the date of purchase.

Additional Item(s) Excluded from

Warranty Coverage (if any):

Where to Obtain Service:

Non-functional accessories, supplies, and consumable items.
At a Sharp Authorized Servicer located in the United States.
To find a location of the nearest Sharp Authorized Servicer, call Sharp toll free at 1-800-BE-SHARP.
Ship prepaid or carry in your Product to a Sharp Authorized Servicer.
Be sure to have **Proof of Purchase** available. If you ship the Product, be sure it is insured and packaged securely.

What to do to Obtain Service:

TO OBTAIN SUPPLY, ACCESSORY OR PRODUCT INFORMATION,
CALL 1-800-BE-SHARP.

SHARP

SHARP ELECTRONICS CORPORATION

Sharp Plaza, Mahwah, New Jersey 07430-2135

SHARP CORPORATION

TINSE0281AWZZ

Printed in Malaysia
A9912.HK

Free Manuals Download Website

<http://myh66.com>

<http://usermanuals.us>

<http://www.somanuals.com>

<http://www.4manuals.cc>

<http://www.manual-lib.com>

<http://www.404manual.com>

<http://www.luxmanual.com>

<http://aubethermostatmanual.com>

Golf course search by state

<http://golfingnear.com>

Email search by domain

<http://emailbydomain.com>

Auto manuals search

<http://auto.somanuals.com>

TV manuals search

<http://tv.somanuals.com>