



OPERATING INSTRUCTIONS





VR-654BD

BLU-RAY RECEIVER



Introduction

READ THIS BEFORE OPERATING YOUR UNIT

 <div style="border: 1px solid black; padding: 2px; display: inline-block; text-align: center;"> CAUTION <small>RISK OF ELECTRIC SHOCK DO NOT OPEN</small> </div> 	 <p>This symbol is intended to alert the user to the presence of uninsulated "dangerous voltage" within the product's enclosure that may be of sufficient magnitude to constitute a risk of electric shock to persons.</p>
<p>CAUTION : TO REDUCE THE RISK OF ELECTRIC SHOCK, DO NOT REMOVE COVER (OR BACK). NO USER-SERVICEABLE PARTS INSIDE. REFER SERVICING TO QUALIFIED SERVICE PERSONNEL.</p>	 <p>This symbol is intended to alert the user to the presence of important operating and maintenance (servicing) instructions in the literature accompanying the appliance.</p>

WARNING : TO REDUCE THE RISK OF FIRE OR ELECTRIC SHOCK, DO NOT EXPOSE THIS APPLIANCE TO RAIN OR MOISTURE.

Caution regarding installation

Note : For heat dispersal, do not install this unit in a confined space such as a bookcase or similar enclosure.

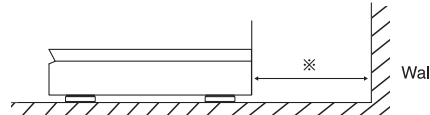
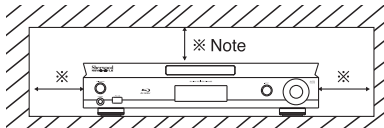

Do not block ventilation openings or stack other equipment on the top.

**CLASS 1
LASER PRODUCT**

CAUTION
Invisible laser radiation when the unit is open.
Do not stare into beam.

CAUTION : USE OF ANY CONTROLS, ADJUSTMENTS, OR PROCEDURES OTHER THAN THOSE SPECIFIED HEREIN MAY RESULT IN HAZARDOUS RADIATION EXPOSURE.

FOR YOUR SAFETY

<p>EUROPE AUSTRALIA</p>	<p>220 V - 240 V</p>	<p>Units shipped to Australia are designed for operation on 240 V AC only. To ensure safe operation, the three-pin plug supplied must be inserted only into a standard three-pin power point which is effectively earthed through the normal household wiring. Extension cords used with the equipment must be three-core and be correctly wired to provide connection to earth. Improper extension cords are a major cause of fatalities. The fact that the equipment operates satisfactorily does not imply that the power point is earthed and that the installation is completely safe. For your safety, if in any doubt about the effective earthing of the power point, consult a qualified electrician. PAN-EUROPEAN UNIFIED VOLTAGE All units are suitable for use on supplies 220-240 V AC.</p>
------------------------------------	-------------------------------------	---

Information for Users on Collection and Disposal of Old Equipment and used Batteries

These symbols on the products, packaging, and/or accompanying documents mean that used electrical and electronic products and batteries should not be mixed with general household waste. For proper treatment, recovery and recycling of old products and used batteries, please take them to applicable collection points, in accordance with your national legislation.

By disposing of these products and batteries correctly, you will help to save valuable resources and prevent any potential negative effects on human health and the environment which could otherwise arise from inappropriate waste handling.

For more information about collection and recycling of old products and batteries, please contact your local municipality, your waste disposal service or the point of sale where you purchased the items.

Pb

[Information on Disposal in other Countries outside the European Union]
These symbols are only valid in the European Union. If you wish to discard these items, please contact your local authorities or dealer and ask for the correct method of disposal.

Note for the battery symbol (bottom two symbol examples):
The sign Pb below the symbol for batteries indicates that this batteries contains lead.

CAUTION

- Leave a space around the unit for sufficient ventilation.
 - Avoid installation in extremely hot or cold locations, or in an area that is exposed to direct sunlight or heating equipment.
 - Keep the unit free from moisture, water, and dust.
 - Do not let foreign objects in the unit.
 - The ventilation should not be impeded by covering the ventilation openings with items, such as newspapers, table-cloths, curtains, etc.
 - No naked flame sources, such as lighted candles, should be placed on the unit.
 - Please be care the environmental aspects of battery disposal.
 - The unit shall not be exposed to dripping or splashing for use.
 - No objects filled with liquids, such as vases, shall be placed on the unit.
 - Do not let insecticides, benzene, and thinner come in contact with the set.
 - Never disassemble or modify the unit in any way.
- Notes on the AC power cord and the wall outlet.**
- The unit is not disconnected from the AC power source(mains) as long as it is connected to the wall outlet, even if the unit has been turned off.
 - To completely disconnect this product from the mains, disconnect the plug from the wall socket outlet.
 - When setting up this product, make sure that the AC outlet you are using is easily accessible.
 - Disconnect the plug from the wall outlet when not using the unit for long periods of time.

PRECAUTIONS

■Moisture condensation

Moisture may form on the lens in the following conditions.

- Immediately after a heater has been turned on.
- In a steamy or very humid room.
- When this unit is moved from a cold place to a warm one.

If moisture forms inside this unit, it may not operate properly.

In this case, turn on the power and wait about one hour for the moisture to evaporate.

■If there is noise interference on the TV while a broadcast is being received.

Depending on the reception condition of the TV, interference may appear on the TV screen while you are watching a TV broadcast and this unit is left on. This is not a malfunction of this unit or the TV. To watch a TV broadcast, turn off this unit.

■Do not transport this unit with discs left in it.

■Do not place on the component that generates heat.

If so, the temperature inside this unit rises and malfunction may occur.

CONTENTS

• Introduction	
READ THIS BEFORE OPERATING YOUR UNIT	2
• System Connections	5
• Front Panel Controls	10
• Universal Remote Controls	11
ENTERING A SETUP CODE	12
OPERATING COMPONENTS WITH REMOTE CONTROL	13
REMOTE CONTROL OPERATION RANGE	13
LOADING BATTERIES	13
• Basic Operation	
LISTENING TO A PROGRAM SOURCE	14
OTHER FUNCTIONS	15
SURROUND SOUND	16
ENJOYING SURROUND SOUND	17
SYSTEM SETUP	18
• Operation of BD player	
PRELIMINARY KNOWLEDGE ABOUT DISCS	24
SYMBOL ABOUT INVALID OPERATION	25
PLAYABLE FILES	25
CARE AND HANDLING OF DISCS	25
DEFINITION OF TERMS	26
PLAYING A DISC	28
ENJOYING BONUSVIEW OR BD-LIVE	34
PLAYING FILES	35
• OSD Menu Settings	40
SETTING THE SYSTEM	41
SETTING THE DISPLAY	42
SETTING THE AUDIO	43
SETTING THE LANGUAGE	43
SETTING THE PARENTAL CONTROL	44
SETTING THE NETWORK	45
• Operation of Tuner	
LISTENING TO RADIO BROADCASTS	47
LISTENING TO RDS BROADCASTS (FM ONLY)	49
(RDS Tuner (Regional Option for some countries in Europe, etc.))	
• Troubleshooting Guide	50
• Specifications	52
• Setup Code Table	54
• License	58

System Connections

- Please be certain that this unit is unplugged from the AC outlet before making any connections.
- Since different components often have different terminal names, carefully read the operating instructions of the component connected.
- Be sure to observe the color coding when connecting audio, video and speaker cords.
- Make connections firmly and correctly. If not, it can cause loss of sound, noise or damage to this unit.

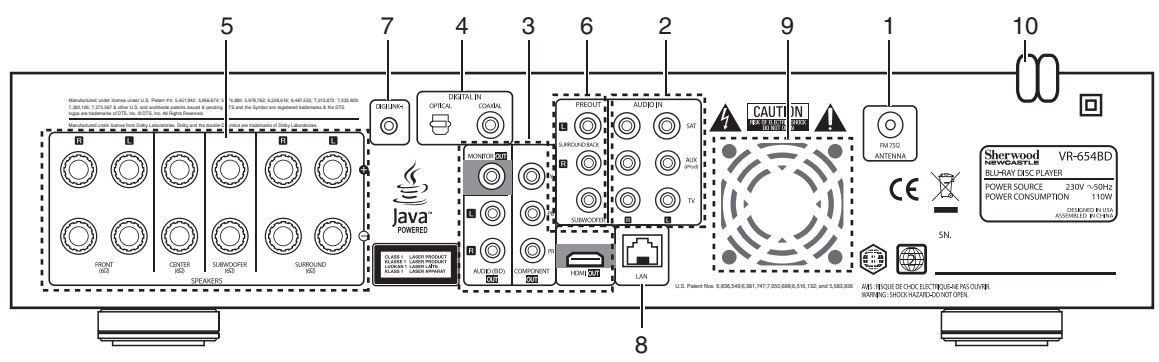

1. CONNECTING ANTENNAS

FM Indoor Antenna

FM Outdoor Antenna

- Change the position of the FM indoor antenna until you get the best reception of your favorite FM stations.
- A 75Ω outdoor FM antenna may be used to further improve the reception. Disconnect the indoor antenna before replacing it with the outdoor one.

2. CONNECTING AUDIO/VIDEO COMPONENTS

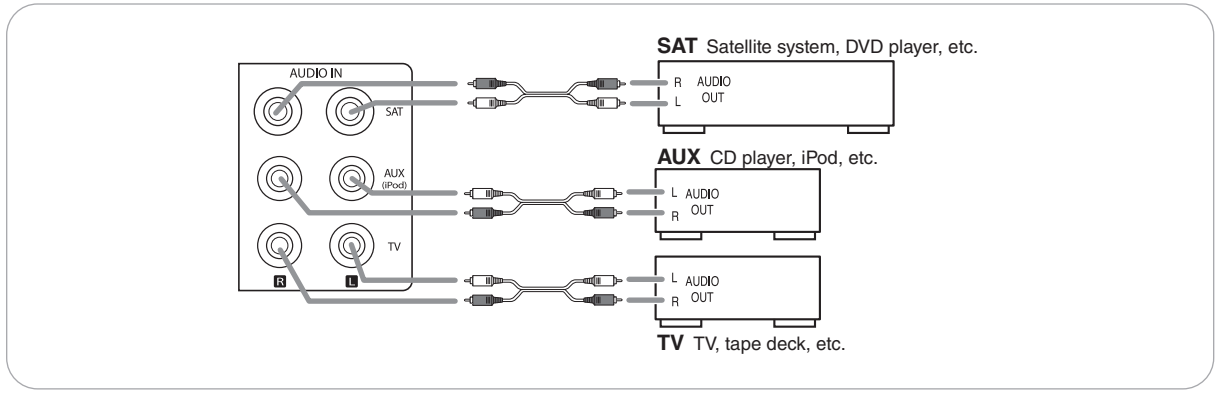

- The AUDIO IN jacks can be connected to the AUDIO OUT jacks of audio or video components.
- **Note :**
- You can connect Apple iPod to this unit via Sherwood iPod dock. If Sherwood iPod dock is connected to DIGI LINK-i jack for system control, you should connect its audio jacks to the "AUX(iPod)" jacks of this unit. Because, when you control your iPod with the unit's remote control, the "AUX" is automatically selected as an input source and the corresponding operation is performed.

3. CONNECTING TV

- There are two types of video jacks (COMPONENT, (composite) VIDEO) for analog video connections and the HDMI connector for digital video and audio connections. Connect them to the corresponding video jacks according to their capability.
- For your reference, the excellence in picture quality is as follows : "HDMI" > "COMPONENT" > "(composite) VIDEO" .
- When making COMPONENT VIDEO connections, connect "Y" to "Y", "Pb" to "Cb"(or "B-Y", "PB") and "Pr" to "Cr"(or "R-Y", "PR").
- To hear the sound that the BD player reproduces from the speakers of your TV, connect the AUDIO OUT jacks to the AUDIO IN jacks of the TV.

■ Notes :

- You don't need to make all kinds of video connections between this unit and your TV.
- Do not connect the unit to the TV through a VCR. Otherwise the picture may be disturbed due to the copy protection function.
- If the resolutions of the video signals which are output from the COMPONENT VIDEO OUTs and the HDMI OUT and your TV are not matched, the picture is not clear, natural or displayed. To prevent it, you should set the resolution to one which the TV can handle. (For details, refer to "Video output resolution" below and "SETTING THE DISPLAY" on page 42.)
- To output the digital audio signals from the HDMI OUT to hear the sound that the BD player reproduces from the speakers of your TV, you should set the HDMI Output to On (Auto). (For details, refer to "SETTING THE AUDIO" on page 43.)
- For stable signal transfer, we recommend using HDMI cords that are a maximum of 5 meters in length.
- Among the components that support HDMI, some components can control other components via the HDMI connector. However, this unit cannot be controlled by another component via the HDMI connector.
- The audio signals from the HDMI connector (including the sampling frequency and bit length) may be limited by the component that is connected.

■ Copyright protection system

- This unit supports HDCP (High-bandwidth Digital Contents Protection), technology to protect copyright of digital video signals against illegal duplication. HDCP must also be supported on the components connected to this unit.
- This unit is HDMI Ver. 1.3 compatible.
- HDMI, the HDMI logo and High-Definition Multimedia Interface are trademarks or registered trademarks of HDMI licensing LLC.

■ Video output resolution

- The video output resolution differs depending on the Resolution setting.
(For details, refer to "SETTING THE DISPLAY" on page 42.)

Resolution setting	Video OUTs		
	(Composite) VIDEO OUT	COMPONENT OUTs	HDMI OUT
HDMI Auto	480i(NTSC)(or 576i(PAL))	1080i ^{*1,*2}	highest resolution
1080p	480i(NTSC)(or 576i(PAL))	1080i ^{*1,*2}	1080p
1080i	480i(NTSC)(or 576i(PAL))	1080i ^{*1,*2}	1080i
720p	480i(NTSC)(or 576i(PAL))	720p ^{*1,*2}	720p
480p	480i(NTSC)(or 576i(PAL))	480p(NTSC)(or 576p(PAL))	480p(NTSC)(or 576p(PAL))
480i	480i(NTSC)(or 576i(PAL))	480i(NTSC)(or 576i(PAL))	480i(NTSC)(or 576i(PAL))

*1 : • When the COMPONENT OUTs and the HDMI OUT are connected to your TV, the video signals of 480i(NTSC)(or 576i(PAL)) will be output.

*2 : • When the HDMI OUT is not connected to your TV and the copy protected DVD Videos are played, the video signals of 480p(or 576p) will be output.

■ Notes :

- If the resolution of video signal to be output from COMPONENT OUTs or HDMI OUT does not match that of your TV, the picture is not clear, natural or displayed.
Should this happen, first make (composite) video connection between this unit and TV, and select the (composite) VIDEO as an input source on the TV to display the setting menu, then set the Resolution correctly. (For details on the resolution acceptable for your TV, refer to its operating instructions.)
- When the HDMI OUT connector is connected to your TV, the TV reports to this unit what resolutions it supports. Therefore, if you set the Resolution to HDMI Auto, this unit outputs the video signals of the highest resolution acceptable for your TV. In this case, you cannot select the resolution unacceptable for your TV.

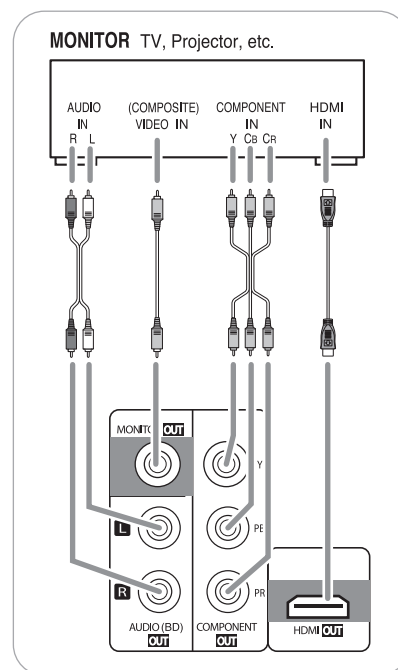

4. CONNECTING DIGITAL INs

- The OPTICAL and the COAXIAL DIGITAL OUTs of the components that are connected to this unit can be connected to these DIGITAL INs.
- A digital input should be connected to the components such as a CD player, DVD player, etc. capable of outputting DTS Digital Surround, Dolby Digital or PCM format digital signals, etc.
- When making the COAXIAL DIGITAL connection, be sure to use a 75 Ω COAXIAL cord, not a conventional AUDIO cord.

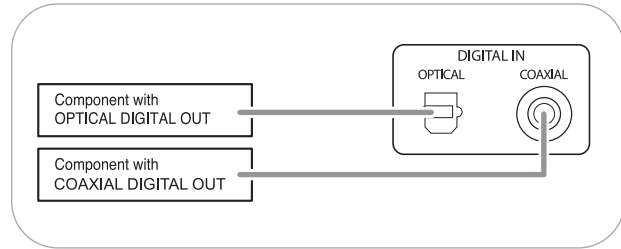

■ Notes :

- Be sure to make either a OPTICAL or a COAXIAL DIGITAL connection on each component. (You don't need to do both.)
- If you connect the DIGITAL INs to your components, you should assign the DIGITAL INs correctly. (For details, refer to "When SAT, TV, AUX is selected as an input source" on page 14.)

5. CONNECTING SPEAKERS

- Be sure to connect speakers firmly and correctly according to the channel(left and right) and the polarity (+ and -). If the connections are faulty, no sound will be heard from the speakers, and if the polarity of the speaker connection is incorrect, the sound will be unnatural and lack bass.
- For installing the speakers, refer to "Speaker placement" on page 8.
- After installing the speakers, first adjust the speaker settings according to your environment and speaker layout. (For details, refer to "Setting the speaker setup" on page 20.)
- Depending on whether the type of your subwoofer is the passive subwoofer or active (powered) subwoofer, connect it as follows :
 - * Connect the SUBWOOFER terminals to the passive subwoofer.
 - * Connect the SUBWOOFER PREOUT jack to the active subwoofer. (For details, refer to "CONNECTING PREOUTs" below.)

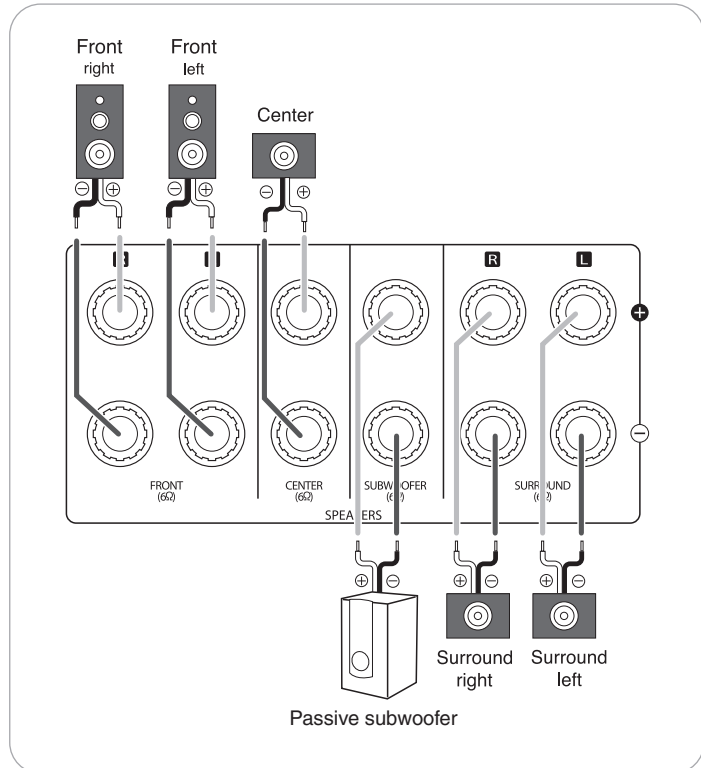

Caution :

- Be sure to use the speakers with the impedance of 6 ohms or above.
- Do not let the bare speaker wires touch each other or any metal part of this unit. This could damage this unit and/or the speakers.
- Never touch the speaker terminals while the AC input cord is connected to the wall AC outlet. Doing so could result in electric shocks.

■ Connecting speaker wire

<p>1. Strip away approx. 10 mm (3/8 inch) of wire insulation, then twist the wire ends tight.</p>	<p>2. Loosen by turning the speaker terminal counter-clockwise.</p>	<p>3. Insert the bare part of the wire.</p>	<p>4. Tighten by turning it clockwise.</p>
---	---	---	--

6. CONNECTING PREOUTs

- Use these jacks when adding additional speakers for 7.1 or 6.1 channel playback.
- Connect the SURROUND BACK PREOUT jacks to the power amplifier connected to speakers.
- When using only one surround back speaker, connect the SURROUND BACK Left jack to the power amplifier.
- To emphasize the deep bass sounds, connect a powered subwoofer to the SUBWOOFER PREOUT jack.

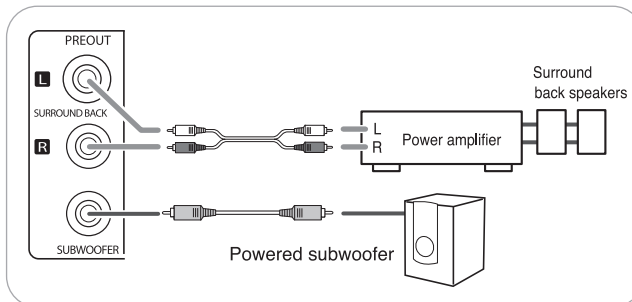

Speaker placement

Ideal speaker placement varies depending on the size of your room and the wall coverings, etc. The typical example of speaker placement and recommendations are as follows :

■ Front left and right speakers and center speaker

- Place the front speakers with their front surfaces as flush with TV or monitor screen as possible.
- Place the center speaker between the front left and right speakers and no further from the listening position than the front speakers.
- Place each speaker so that sound is aimed at the location of the listener's ears when at the main listening position.

■ Surround left and right speakers

- Place the surround speakers approximately 1 meter (40 inches) above the ear level of a seated listener on the direct left and right of them or slightly behind.

■ Surround back left and right speakers

- Place the surround back speakers at the back facing the front at a narrower distance than front speakers.
- When using a single surround back speaker, place it at the rear center facing the front at a slightly higher position (0 to 20 cm) than the surround speakers.
- We recommend installing the surround back speaker(s) at a slightly downward facing angle. This effectively prevents the surround back channel signals from reflecting off the TV or screen at the front center, resulting in interference and making the sense of movement from the front to the back less sharp.

■ Subwoofer

- The subwoofer reproduces powerful deep bass sounds. Place a subwoofer anywhere in the front as desired.

■ Notes :

- When using a conventional TV, to avoid interference with the TV picture, use only magnetically shielded front left and right and center speakers.
- To obtain the best surround effects, the speakers except the subwoofer should be full range speakers.

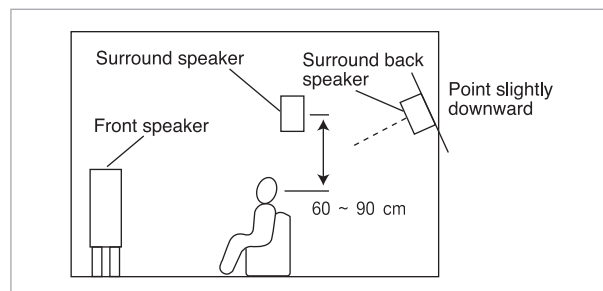
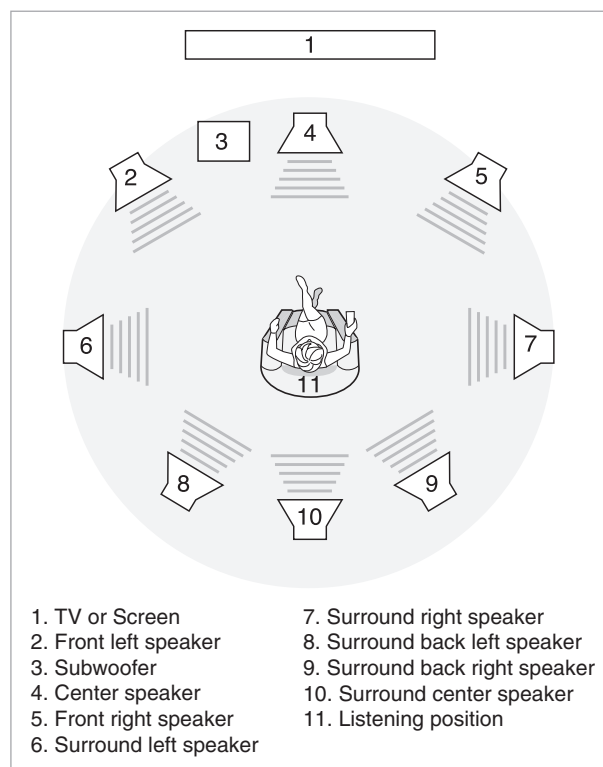

7. CONNECTING FOR SYSTEM CONTROL

- Connect this jack to the DIGILINK-i jack of Sherwood iPod dock that allows you to control the iPod with the unit's remote control.

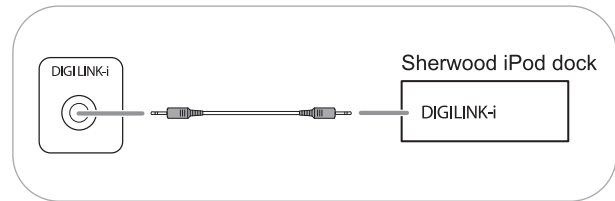

ENGLISH

8. CONNECTING TO NETWORK

- You can enjoy a variety of contents with interactive functions by connecting to the internet when playing BD-LIVE compatible discs on the BD player.
- Connect the LAN connector of this unit to your internet source.

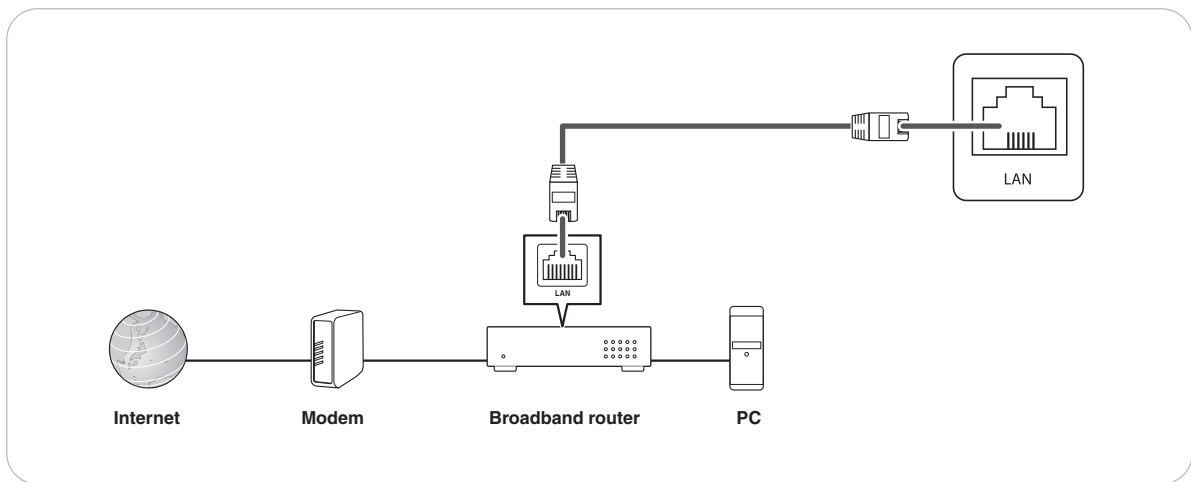

■ Notes :

- After making a broadband internet connection, you should set the communication setting. (For details, refer to "SETTING THE NETWORK" on page 45.)
- When using a broadband internet connection, a contract with an internet service provider is required. For more information, contact your nearest internet service provider.
- Refer to the operating instructions of the equipment because the connected equipment and connection method may differ depending on your internet environment.
- Use a LAN cable/router supporting 10 BASE-T/100 BASE-TX.
- Some LAN cables are easily affected by noise.
We recommend using a shield type cable.

9. COOLING FAN

- Cooling fan operates to prevent the temperature inside this unit from rising. To allow for proper ventilation, maintain a certain space behind this unit.

■ Note :

- While the fan is operating, the faint fan noise may be generated.

10. AC INPUT

- Plug this cord into a wall AC outlet.

ENGLISH

Front Panel Controls

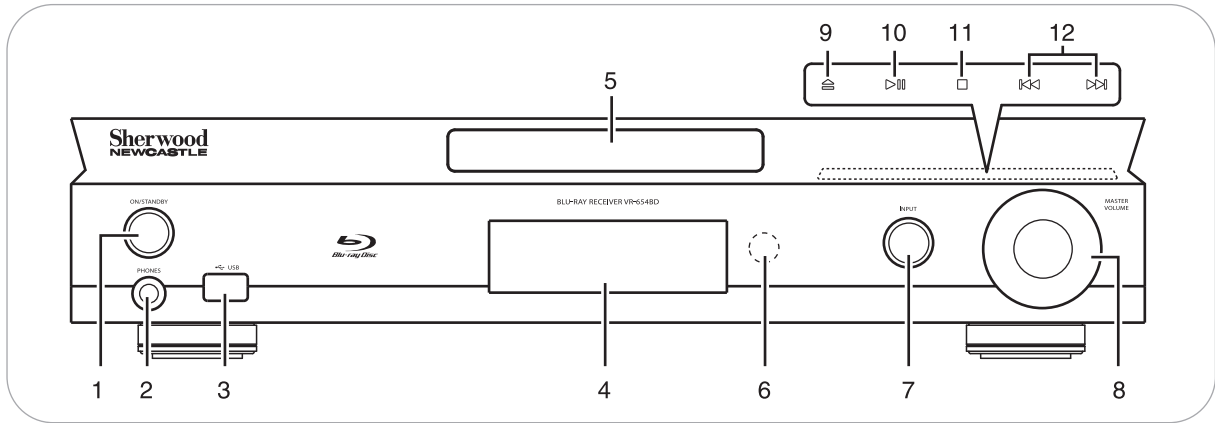

- | | |
|--------------------------------------|--|
| 1. POWER ON/STANDBY button/indicator | 6. REMOTE SENSOR |
| 2. HEADPHONE jack | 7. INPUT SELECTOR button |
| 3. USB connector | 8. MASTER VOLUME CONTROL knob |
| For details, see below. | 9. OPEN/CLOSE (☰) button |
| 4. FLUORESCENT DISPLAY | 10. PLAY/PAUSE (▶) button |
| For details, see below. | 11. STOP (□) button |
| 5. DISC TRAY | 12. FORWARD/BACKWARD SKIP (▶▶ / ◀◀) buttons. |

■ FLUORESCENT DISPLAY

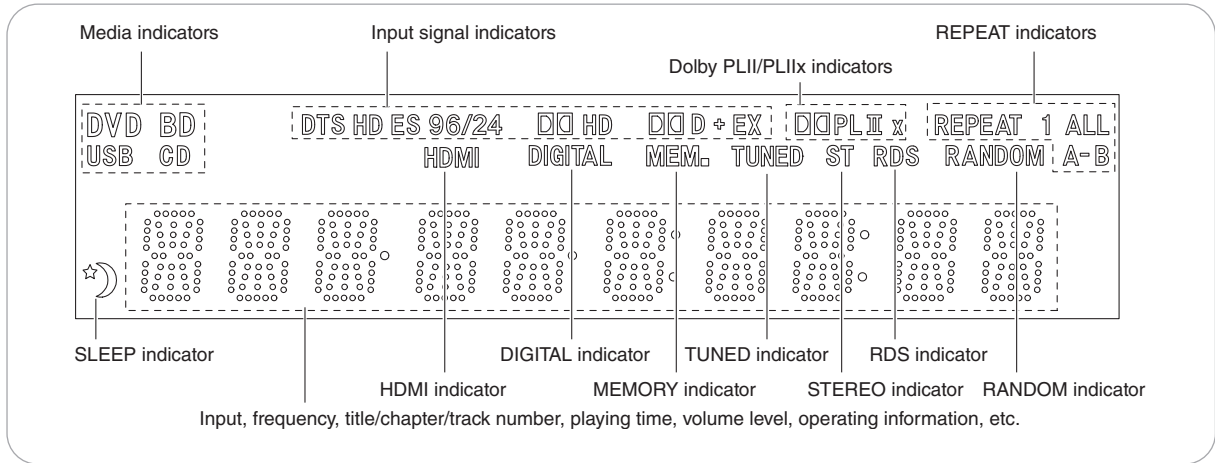

■ USB CONNECTOR

- This connector can be connected to a USB memory device for playback of MP3, WMA or JPEG files, etc. stored on it. (For details, refer to "PLAYING FILES" on page 35.)
- To enjoy BONUSVIEW and BD-LIVE functions, you can connect a USB memory device (minimum 1GB capacity (2GB or more recommended)) supporting FAT 32 and USB 2.0 High Speed (480 Mbit/s) to this connector, too. (For details, refer to "ENJOYING BONUSVIEW OR BD-LIVE" on page 34.)

■ Notes :

- Do not use a USB extension cable when connecting a USB memory device to this connector.
- After playback of files or Virtual Package/BD-LIVE data, remove the USB memory device in the stop mode or the standby mode.

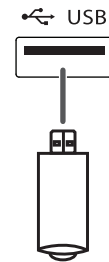

Universal Remote Controls

This universal remote control can operate not only this unit but also most popular brands of video components such as TVs, cable boxes, satellite receivers, etc.

- To operate 3 components other than this unit, you should enter the setup code for each component. (For details, refer to "ENTERING A SETUP CODE" on page 12.)
- The numbered buttons on the remote control have different functions in other device modes. For details, refer to "FUNCTION TABLE of the NUMBERED BUTTONS" on the next page.

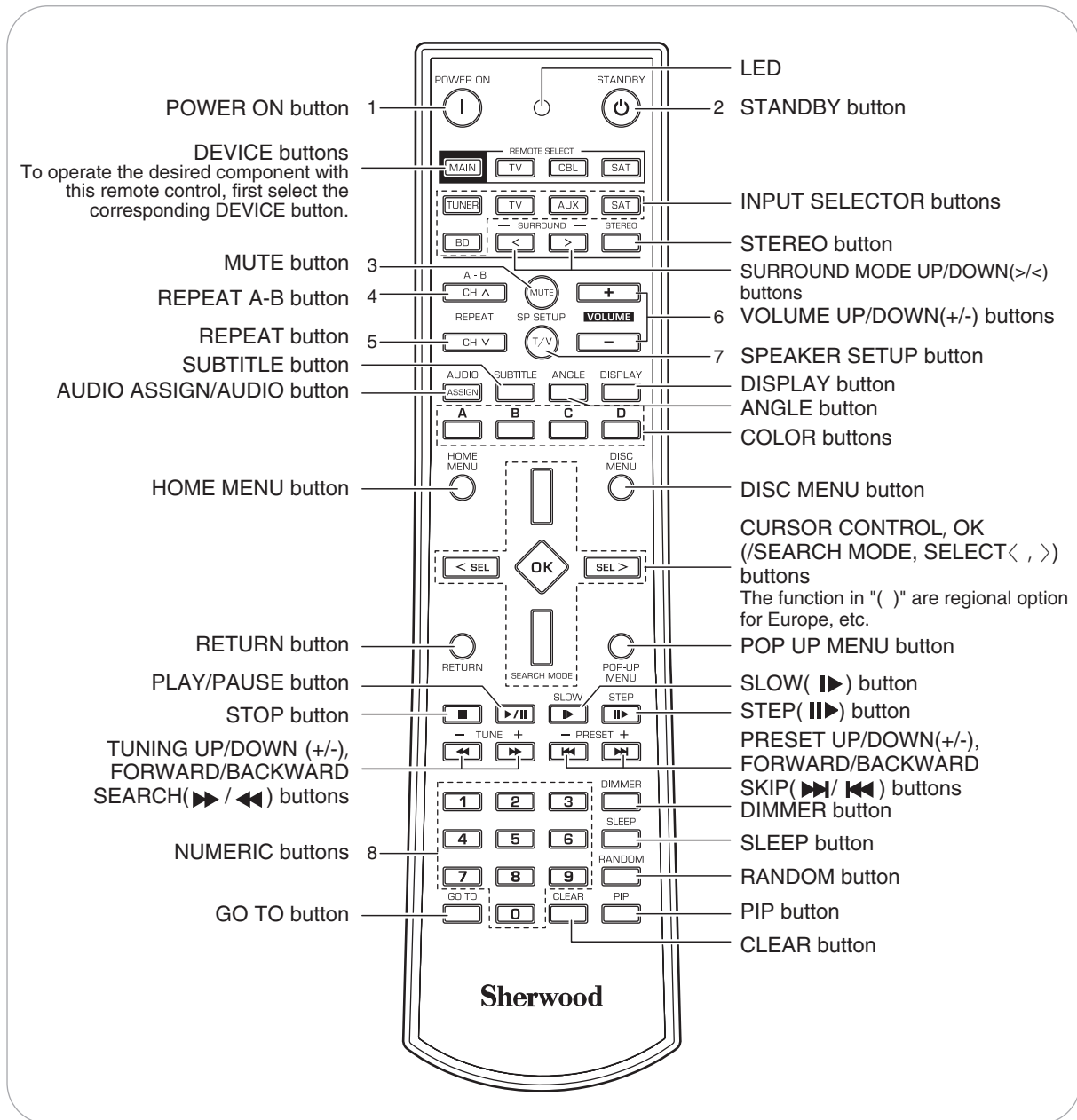

Note :

- You can use the COLOR buttons to select the items on some BD menus during operation of BD player.

FUNCTION TABLE of the NUMBERED BUTTONS.

Device to be controlled	TV (for TV)	CBL (for Cable box)	SAT (for Satellite receiver)
1 POWER ON 	POWER ON	POWER ON	POWER ON
2 STANDBY 	STANDBY	STANDBY	STANDBY
3 MUTE 	MUTE	MUTE	MUTE
4 A - B CH ▲ 	CHANNEL UP	CHANNEL UP	CHANNEL UP
5 REPEAT CH ▼ 	CHANNEL DOWN	CHANNEL DOWN	CHANNEL DOWN
6 	VOLUME UP/DOWN (+/-)	VOLUME UP/DOWN (+/-)	VOLUME UP/DOWN (+/-)
7 SP SETUP TV 	INPUT SELECTOR	INPUT SELECTOR	INPUT SELECTOR
8 	NUMERIC	NUMERIC	NUMERIC

Notes :

- Some functions for each component may not be available or may work differently.
- Depending on other kinds of components that are available for each DEVICE button, some functions may not be available or may work differently, too.
- For details about functions, refer to the operating instructions of each component.

ENTERING A SETUP CODE

- This remote control can control up to 3 different components.
- Before operating video components other than this unit with using this remote control, the setup code for each component should be entered.

1. Turn on the component you want to operate.
2. Find the setup codes according to the type and the brand name of your component, referring to "Setup Code Table" on page 54.
3. Press and hold down both the OK button and the DEVICE button you want for more than 1 seconds.

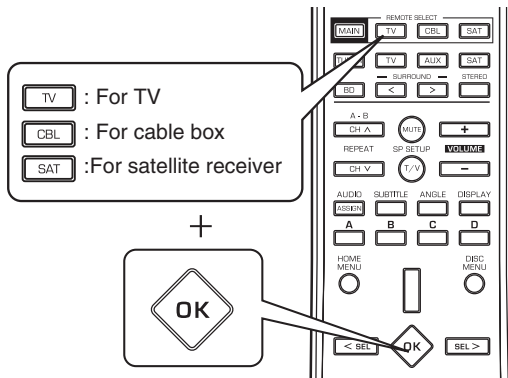

- The LED will flicker once.

Note :

- The MAIN button is unavailable for the components other than this unit.

4. Enter a 3 digit code.

Example: When entering "001".

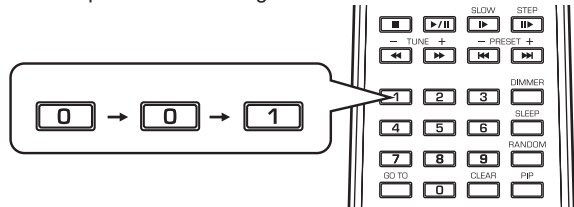

- If entering is performed successfully, the LED will flicker twice.
- To be sure that the setup code is correct, press the POWER ON (or STANDBY) button, aiming the remote control at the remote sensor on the component. If your component is turned off, the setup code is correct.
- When your component is not turned off, repeat the above steps 2 to 4, trying each code for your component until you find one that works.

Notes:

- If the LED did not flicker twice, then repeat the above steps 3 to 4 and try entering the same code again.
- Manufacturers may use different setup codes for the same product category. For that reason, it is important that you check to see if the code you have entered operates as many controls as possible. If only a few functions operate, check to see if another code will work with more buttons.

5. Repeat the above steps 1 to 4 for each of your components.

OPERATING COMPONENTS WITH REMOTE CONTROL

1. Enter the setup code for each component other than this unit you wish to control. (For details, refer to "ENTERING A SETUP CODE" on page 12.)
2. Turn on the component you want to operate.
3. Press the DEVICE button on the remote control corresponding to the component you wish to operate.

Example) When selecting "MAIN" to operate this unit.

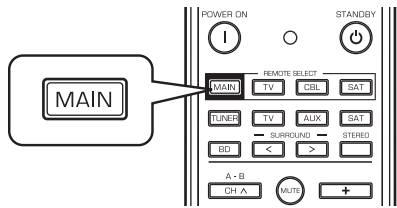

4. Aim the remote control at the REMOTE SENSOR of the component you wish to control and press the button corresponding to the operation you want.

REMOTE CONTROL OPERATION RANGE

- Use the remote control within a range of about 7 meters (23 feet) and angles of up to 30 degrees aiming at the remote sensor.

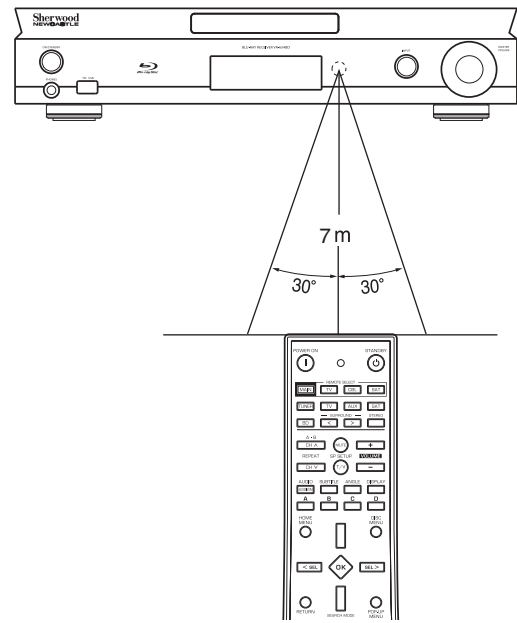

- Note :
- Remote operation may become unreliable if the remote sensor is exposed to strong light such as direct sunlight or inverted fluorescent.

LOADING BATTERIES

- When the remote control does not operate, the old batteries should be replaced. In this case, load new batteries within several minutes after removing old batteries.
- If the batteries are removed or have been exhausted for a longer period of time, memorized contents will be cleared. Should this happen, you should memorize them again.

1. Remove the cover.

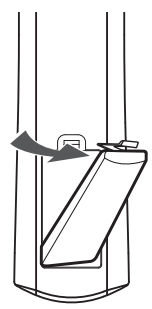

2. Load two batteries ("AAA" size, 1.5V) matching the polarity.

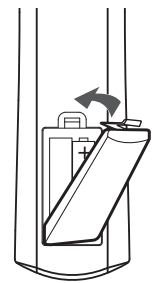

- Remove the batteries when they are not used for a long time.
- Do not use the rechargeable batteries (Ni-Cd type).
- Be sure to use alkaline batteries.

Basic Operation

Notes:

- Before operating this receiver with the supplied remote control, refer to "Universal Remote Controls" on page 11 for details about operation.
- Before operating this receiver, first set this unit as desired for optimum performance, doing the setup procedures. (For details, refer to "SYSTEM SETUP" on page 18.)

LISTENING TO A PROGRAM SOURCE

1. Turn the power on.



- Each time the POWER ON/STANDBY button is pressed, the unit is turned on to enter the operating mode (the POWER ON/STANDBY indicator lights up blue) or off to enter the standby mode (the POWER ON/STANDBY indicator lights up amber).
- On the remote control, press the POWER ON button to enter the operating mode or press the STANDBY button to enter the standby mode.

Standby mode

This means that the unit is not disconnected from the AC mains and a small amount of current is retained to support the operation readiness.

2. Select the desired input source.

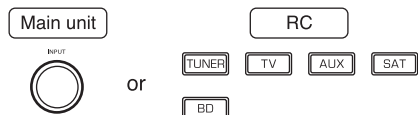

- Each time the INPUT SELECTOR button on the front panel, the input source changes as follows :
→ FM → SAT → TV → AUX → BD/DVD (frequency display)
- Each time the "TUNER" button on the remote control is pressed, the FM mode changes as follows:
→ FM ST → FM MONO

Note :

- During playback of BD Video or DVD Video on the BD player, if an input source is selected and then BD/DVD is selected within 3 minutes again, playback will be paused on that point at which an input source is selected.

When SAT, TV, AUX is selected as an input source

3. Select the digital or analog input connected as desired.



- Each time this button is pressed, the corresponding input is selected as follows :
→ ANLG(Analog) → COAX(Coaxial) → OPTI(Optical)

Note:

- When the selected digital input is not connected, the "DIGITAL" indicator flickers and the analog input is automatically selected.

4. Operate the selected component for playback.

- When playing back the program sources with surround sound, refer to "ENJOYING SURROUND SOUND" on page 17.

5. Adjust the (overall) volume to a comfortable listening level.

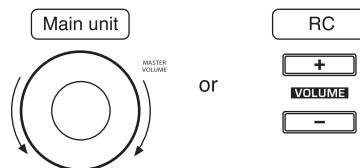

6. To mute the sound.

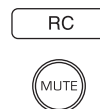

- "MUTE" is displayed.
- To resume the previous sound level, press it again.

7. To listen with the headphones.

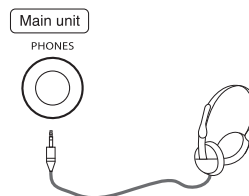

- Then the "SPK OFF" is displayed and the sound from the speakers is cut off.

Note:

- Be careful not to set the volume too high when using headphones.

OTHER FUNCTIONS

Operating the sleep timer

- The sleep timer allows the system to continue to operate for a specified period of time before automatically shutting off.
- To set the receiver to automatically turn off after the specified period of time.



- Each time this button is pressed, the sleep time changes as follows:

→ 30 → 60 → 90 → OFF
Unit : minutes

- While operating the sleep timer, "  " lights up.
- When the sleep time is selected, the fluorescent display is dimly lit.

Adjusting the brightness of the fluorescent display

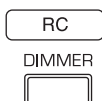

- Each time this button is pressed, the brightness of the fluorescent display changes as follows:

→ ON → dimmer → OFF

- In the display OFF mode, if some buttons are pressed, the display OFF mode may be canceled for several seconds depending on operation status.

Displaying the operation status

During playback,

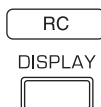

- Each time this button is pressed, the display mode changes as follows:

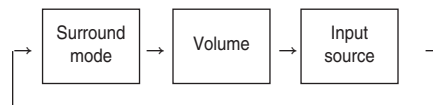

- When the BD/DVD is selected as an input source, see "Displaying disc information" on page 30 and "Displaying file information" on page 37.
- When RDS tuner function is available in your country, for details on the FM mode information, see "Displaying RDS information" on page 49.

SURROUND SOUND

- This receiver incorporates a sophisticated Digital Signal Processor that allows you to create optimum sound quality and sound atmosphere in your personal Home Theater.

Surround modes

■ DTS Digital Surround

DTS Digital Surround(also called simply DTS) supports up to 5.1 discrete channels and uses less compression for high fidelity reproduction. Use it with DVDs and CDs bearing the DTS logo.

■ DTS-ES™ Discrete 6.1

This is a 6.1 channel discrete digital audio format adding a surround back channel to the DTS digital surround sound. The seven totally separate audio channels provide better spatial imaging and 360 degrees sound localization, perfect for sounds that pan across the surround channels. Use it with DVDs bearing the DTS-ES logo, especially those with a DTS-ES Discrete sound track.

■ DTS - ES™ Matrix 6.1

This is a 6.1 channel discrete digital audio format inserting a surround back channel to the DTS digital surround sound through matrix encoding. Use it with DVDs bearing the DTS-ES logo.

■ DTS Neo : 6™ surround

DTS Neo : 6 is a matrix decoding technology for achieving 7.1 channel surround playback with 2 channel sources.

■ DTS 96/24

This is high resolution DTS with a 96 kHz sampling rate and 24 bit resolution, providing superior fidelity. Use it with DVDs bearing the DTS 96/24 logo.

■ DTS-HD High Resolution Audio

Developed for use with HDTV, including the new video disc formats Blu-ray and HD DVD, this is the latest multi-channel audio format from DTS. It supports up to 7.1 channels with 96 kHz/24 bit sampling rate and signal resolution.

■ DTS-HD Master Audio

Designed to take full advantage of the additional storage space offered by the new Blu-ray and HD DVD disc formats, this new DTS format offers up to 7.1 discrete channels of uncompressed digital audio with 96 kHz/24 bit sampling rate and signal resolution.

Manufactured under license under U.S. Patent #'s: 5,451,942; 5,956,674; 5,974,380; 5,978,762; 6,226,616; 6,487,535; 7,212,872; 7,333,929; 7,392,195; 7,272,567 & other U.S. and worldwide patents issued & pending.

DTS is a registered trademark and the DTS logos, Symbol, DTS-HD and DTS-HD Master Audio are trademarks of DTS, Inc.

© 1996-2008 DTS, Inc. All Rights Reserved.

■ Dolby Digital

Dolby Digital is the multi-channel digital signal format developed by Dolby Laboratories. Discs bearing the Dolby Digital logo includes the recording of up to 5.1 channels of digital signals. This will put you right in the middle of the action, just like being in a movie theater or concert hall.

■ Dolby Digital EX

This mode expands 5.1-channel sources for 6.1/7.1 channel playback. It's especially suited to Dolby Digital EX soundtracks that include a matrix-encoded surround back channel. The additional channel adds an extra dimension and provides an enveloping surround sound experience, perfect for rotating and fly-by sound effects.

■ Dolby Digital Plus

Developed for use with HDTV, including the new video disc formats Blu-ray and HD DVD, this is the latest multichannel audio format from Dolby. It supports up to 7.1 channels with 48 kHz/24-bit sampling rate and signal resolution.

■ Dolby TrueHD

Designed to take full advantage of the additional storage space offered by the new Blu-ray and HD DVD disc formats, this new Dolby format offers up to 7.1 discrete channels of lossless audio performance with 96 kHz/24 bit sampling rate and signal resolution.

■ Dolby Pro Logic IIx surround

This mode expands any 2-channel source for 7.1-channel playback. It provides a very natural and seamless surround sound experience that fully envelopes the listener. As well as music and movies, video games can also benefit from the dramatic spatial effects and vivid imaging. It includes "Dolby Pro Logic IIx Movie" suited for playing movies, "Dolby Pro Logic IIx Music" suited for playing music and "Dolby Pro Logic IIx Game" suited for playing games.

■ Dolby Pro Logic II surround

If you are not using any surround back speakers, Dolby Pro Logic II surround will be used instead of Dolby Pro Logic IIx surround. It includes Dolby Pro Logic II Movie, Dolby Pro Logic II Music and Dolby Pro Logic II Game like Dolby Pro Logic IIx surround.

■ Dolby Pro Logic

This mode expands any 2-channel source (, including Dolby Surround source) for 4 channel (front left, center, front right and surround) playback. The surround channel is monaural, but is played through two surround speakers.

Manufactured under license from Dolby Laboratories. Dolby and the double-D symbol are registered trademarks of Dolby Laboratories.

- The following modes apply conventional 2-channel signals such as digital PCM or analog stereo signals to high performance Digital Signal Processor to recreate sound fields artificially. Select one of the 7 provided surround modes according to the program source you want to play.

■ **Movie**

This mode provides the effect of being in a movie theater when watching a action movies with dynamic soundtracks.

■ **Drama**

This mode is suitable for movies with lots of dialog.

■ **Game**

This mode is suitable for video games.

■ **Stadium**

This mode provides the expansive sound field to achieve the true stadium effect when watching baseball or soccer games.

■ **Classic**

This mode provides the acoustic effects of a large concert hall for classical music.

■ **Hall**

This mode provides the ambience of a concert hall for rock or pop music.

■ **MULTI CH Stereo**

This mode is for enjoying stereo sound from all speakers..

ENJOYING SURROUND SOUND

■ **Notes:**

- Before surround playback, first perform the speaker setup procedure, etc. on the SETUP menu for optimum performance. (For details, refer to "Setting the speaker setup" on page 20.)
- Select the desired surround mode.

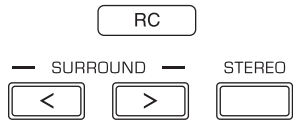

- Press the SURROUND MODE UP/DOWN () / () buttons to select a surround mode or press the STEREO button to select the stereo mode.
- Each time the SURROUND MODE UP/DOWN () / () buttons are pressed, the surround mode changes as follows :
 Auto surround mode : The truest possible playback mode will be automatically selected according to the number of channels in the signal being input.
 Manual surround mode : You can select the desired of different surround modes selectable for the signal being input.

- Depending on the input source you select, the surround modes are selected as follows :

■ **When selecting an input source other than BD/DVD**

Signal format being input	Selectable surround mode
Dolby Digital EX 6.1 channel sources	AUTO SURROUND, corresponding DOLBY mode, STEREO
Dolby Digital 5.1 channel sources	AUTO SURROUND, <DOLBY DIGITAL EX, DOLBY D+PLIIX MUSIC>, (DOLBY D+ PLIIX MOVIE), [DOLBY DIGITAL], STEREO
Dolby Digital 2 channel sources	AUTO SURROUND, <DOLBY PLIIX MOVIE, DOLBY PLIIX MUSIC, DOLBY PLIIX GAME>, [DOLBY PLII MOVIE, DOLBY PLII MUSIC, DOLBY PLII GAME], DOLBY PRO LOGIC, STEREO
DTS ES Discrete 6.1 channel sources, DTS ES Matrix 6.1 channel sources, DTS 96/24 sources	AUTO SURROUND, corresponding DTS mode, STEREO
DTS sources	AUTO SURROUND, <DTS+NEO:6, DTS+PLIIX MUSIC>, (DTS+PLIIX MOVIE), [DTS], STEREO
PCM 2 channel sources, PCM multi-channel sources, Analog stereo sources,	AUTO SURROUND, <DOLBY PLIIX MOVIE, DOLBY PLIIX MUSIC, DOLBY PLIIX GAME>, [DOLBY PLII MOVIE, DOLBY PLII MUSIC, DOLBY PLII GAME], DOLBY PRO LOGIC, MOVIE, DRAMA, GAME, STADIUM, CLASSIC, HALL, MULTI CH STEREO, STEREO

■ **When selecting the BD/DVD**

Signal format being input	Selectable surround mode
Dolby Digital Plus sources, Dolby TrueHD sources, Dolby Digital EX 6.1 channel sources, Dolby Digital 5.1 channel sources, DTS-HD High Resolution Audio sources, DTS-HD Master Audio sources, DTS ES Discrete 6.1 channel sources, DTS ES Matrix 6.1 channel sources, DTS 96/24 sources, DTS sources, PCM multi-channel sources, PCM 2 channel sources, Dolby Digital 2 channel sources	AUTO SURROUND, MOVIE, DRAMA, GAME, STADIUM, CLASSIC, HALL, MULTI CH STEREO, STEREO

- Depending on surround back speaker setting, some surround modes can be selected or not as follows:
 < > : Possible only when surround back speaker is not set to "NO".
 [] : Possible only when surround back speaker is set to "NO".
 () : Possible only when surround back speaker is set to "X2".

■ **Note :**

- When listening with the headphones, only the stereo mode can be selected.

SYSTEM SETUP

- The setup menu is displayed on the fluorescent display and allows you to perform the setup procedures easily. In most situations, you will only need to set this once during the installation and layout of your home theater, and it rarely needs to be changed later.

1. Turn the setup menu on.

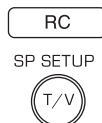

- “SOUND PRMT” will be shown.
- To turn the menu off, press this button again.
- When the RETURN is pressed on a sub-menu, it will return to the previous menu.

2. Select the desired menu using the CURSOR UP/DOWN buttons.

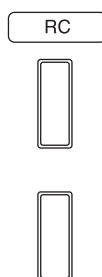

- Each time these buttons are pressed, the setup menu is selected as follows :

→ “SOUND PRMT” ↔ “TONE” ↔ “SPK SET” ←
(Sound Parameter) (Speaker Setup)

- When “TONE” is selected, see “Setting the Tone” on page 23.

3. When selecting the “SOUND PRMT” or the “SPK SET”, press the OK button to enter it’s setup menu.



- When “SPK SET” is selected, see “Setting the speaker setup” on page 20.
- When “SOUND PRMT” is selected, see “Setting the sound parameter” below.

Setting the sound parameter

- You can adjust the different sound parameters for optimum surround effect.

◆ SOUND PRMT	L.SYNC	0 / 0 ~ 9.0	■ : Default settings
	D.M.	CH1 / CH2 / CH1+2	
	DRC	OFF / MID / MAX	
	LFE	0 dB / -10 / OFF	
	C.WIDTH	3 / 0 ~ 7	
	DIMEN	0 / -3 ~ +3	
	PNRM	OFF / ON	

1. Press the CURSOR UP/DOWN buttons to select the desired parameter.

■ Notes :

- “C.WIDTH”, “DIMEN” and “PNRM” can be selected only while listening in Dolby Pro Logic II Music or Dolby Pro Logic IIx Music mode.
- “D.M.” and “DRC” settings are not valid when BD/DVD is selected as an input source.

Continued

2. Press the CURSOR LEFT/RIGHT buttons to adjust the selected parameter as desired.

3. Repeat the above steps 1 and 2 to adjust other parameter.

■When selecting the “L.SYNC (Lip-Sync)”

- There may be a slight time delay between the video and audio signals in case that some video playback equipments may process the video signals later than the audio signals due to signal processing procedure, etc.. Should this happen, you can adjust the time delay of audio signals to synchronize the sound with the picture.
- The time delay can be adjusted with the range of 0.0 ~ 9.0 frames (1 sec. = 30 frames).

■When selecting the “D.M. (Dual Mono)”

- Dual mono software usually is used to put two different mono soundtracks, that you can listen to together or separately, on one DVD, etc. With this setting you can choose which dual mono setting you want to listen to.
- This setting works only with dual mono encoded Dolby Digital and DTS soundtracks.

→ CH 1 : Only channel 1 is heard from the front speakers.

↓

CH 2 : Only channel 2 is heard.

↓

→ CH 1+2 : Both channels are heard.

■When selecting the “DRC (Dynamic Range Control)”

- This function compresses the dynamic range of previously specified parts of Dolby Digital or DTS sound track (with extremely high volume) to minimize the difference in volume between the specified and non-specified parts. This makes it easy to hear all of the sound track when watching movies at night at low levels.

→ OFF : To turn the DRC function off.

↓

MID : To adjust it to “MID” level.

↓

→ MAX : To adjust it to “MAX” level.

■Note :

- In some Dolby Digital or DTS softwares, the DRC setting may not be valid.

■When selecting the “LFE (LFE level)”

- Some Dolby Digital or DTS source, etc. includes LFE (ultra low bass) signals.
- The LFE level can be adjusted as desired.

OFF : To output no sound from the LFE channel.

↓

0 : In general, to set to 0dB (recommended value)

↓

-10: To set to -10 dB for some early DTS software, etc.

■When selecting the “C.WIDTH (Center Width)”

- This adjusts the center image so it may be heard only from the center speaker, only from left/right speakers as a phantom image, or from all three front speakers to varying degrees.
- The control can be set in 8 steps from 0 to 7.

■Note :

- This control valid only when the center speaker is not set to NO.

■When selecting the “DIMEN (Dimension)”

- This gradually adjusts the sound field either towards the front or towards the rear. The control can be set in 7 steps from -3 to +3.

■When selecting the “PNRM (Panorama)”

- This mode extends the front stereo image to include the surround speakers for an exciting “wraparound” effect with side wall imaging. Select “OFF” or “ON”.

Setting the speaker setup

- After you have installed this receiver and connected all the components, you should adjust the speaker settings for the optimum sound acoustic according to your environment and speaker layout.
- Even when you change speakers, speaker positions, or the layout of your listening environment, you should adjust the speaker settings, too.

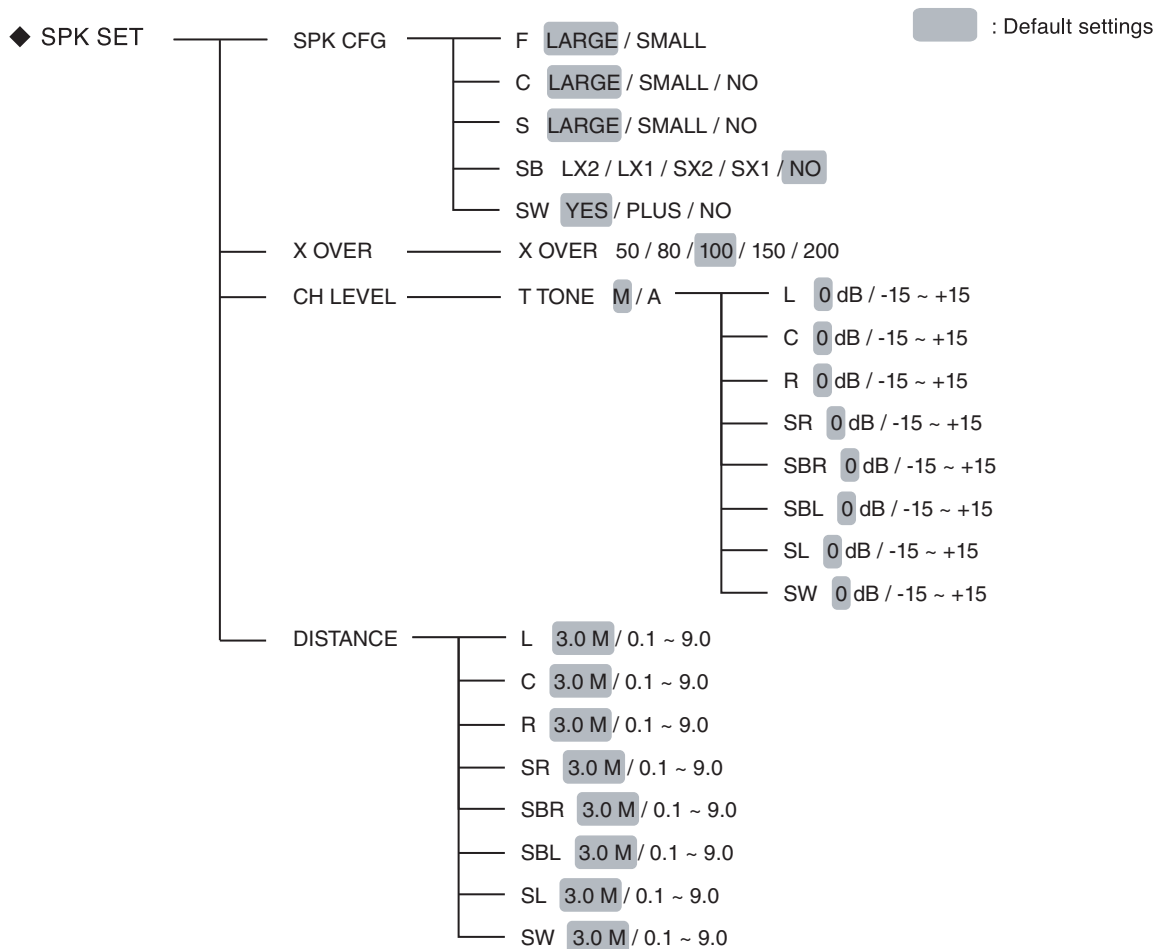

- SPK CFG (SPEAKER CONFIGURATION) : To adjust the speakers depending on whether they are connected or not.
- X OVER (CROSSOVER FREQUENCY) : To select the desired crossover frequency.
- CH (CHANNEL) LEVEL : To adjust each channel level with the test tone.
- DISTANCE (SPEAKER DISTANCE) : To select the distance between the listening position and each speaker to set the delay time automatically for optimum surround playback.

■When selecting the SPEAKER CONFIGURATION

1. Press the CURSOR UP/DOWN buttons to select the “SPK CFG”, then press the OK button.

- Then “F ~” will be displayed.

2. Press the CURSOR UP/DOWN buttons to select the desired speaker.

3. Press the CURSOR LEFT/RIGHT buttons to set the selected speaker as desired.

- Depending on your speaker type, you can select one of these following speaker types.
- Front, Center, Surround and Surround Back speakers :
 LARGE (or L) : Select this when connecting speakers that can fully reproduce sounds below crossover frequency.
 SMALL (or S) : Select this when connecting speakers that can not fully reproduce sounds below crossover frequency.
 When this is selected, sounds below crossover frequency are sent to the subwoofer or speakers which are set to “LARGE” (when not using a subwoofer).
 NO : Select this when no speakers are connected. When this is selected, sounds are sent to the speakers which are not set to “NO”.
 () : Selectable for Surround Back speakers.
- Surround Back speakers :
 X2/X1 : Select the desired depending on the number of speakers connected to SURROUND BACK/PREOUTs.
- SubWoofer :
 YES : Select this to output LFE signals and bass frequencies of channels set to “SMALL” from the subwoofer.
 PLUS : Select this if you want the subwoofer to output bass sound continuously or you want deeper bass (the bass frequencies that would normally come out the front and center speakers are also routed to the subwoofer.)
 NO : Select this when the subwoofer is not connected. The bass frequencies are output from other speakers.

■Notes :

- When speakers are set to “SMALL”, you should set their crossover frequency correctly according to their frequency characteristics. (For details, refer to “When selecting the CROSSOVER FREQUENCY” on page 22.)
- When the “F” (Front) is set to “SMALL”, “C” (Center), “S” (Surround) and “SB” (Surround Back) cannot be set to “LARGE” and the “SW” (SubWoofer) cannot be set to “PLUS” or “NO”.
- When the “S” (Surround) is set to “SMALL”, the “SB” (Surround Back) cannot be set to “L” (Large).

4. Repeat the above steps 2 and 3 until the speakers are all set to the desired mode.

■About the speaker size

- Select “LARGE” or “SMALL” not according to the actual size of the speaker but according to the speaker’s capacity for playing low frequency (bass sound below frequency set on the “CROSSOVER FREQUENCY” menu) signals.
- If you do not know, try comparing the sound at both settings (setting the volume to a level low enough so as not to damage the speakers) to determine the proper setting.

■When selecting the CROSSOVER FREQUENCY

1. Press the CURSOR UP/DOWN buttons to select the "X OVER", then press the OK button.

- Then "X OVER ~" will be displayed.

2. Press the CURSOR LEFT/RIGHT buttons to set the crossover frequency as desired.

- You can select the crossover frequency among 50, 80, 100, 150 and 200 Hz.

■About the crossover frequency

- When speakers are set to "SMALL", low frequencies in those channels that are below the crossover frequency are to output from subwoofer or front speakers which are set to "LARGE" (when not using a subwoofer).
- Refer to the operating instructions of the speakers to be connected. If the frequency range of your speaker is 100Hz ~ 20kHz, the crossover frequency should be set to 100 Hz (or slightly higher).

■When selecting the CHANNEL LEVEL

1. Press the CURSOR UP/DOWN buttons to select the "CH LEVEL", then press the OK button.

- Then "T TONE ~" will be displayed.

2. Press the CURSOR LEFT/RIGHT buttons to select the desired mode.

- Each time these buttons are pressed, the mode changes as follows :

M (MANUAL) : To move the test tone manually from speaker to speaker and to adjust the individual channel levels.

↑

A (AUTO) : To adjust the channel levels as the test tone moves from speaker to speaker automatically.

3. Press the OK button to confirm your selection.

- After the volume increases to the reference level, test tone will be output.
- When the "A" (AUTO) is selected, the test tone will be output from each speaker for 2 seconds.

4. Press the CURSOR LEFT/RIGHT buttons to adjust the level of each channel.

- When the "M" (MANUAL) is selected, select the speakers to be output the test tone with using the CURSOR UP/DOWN buttons.
- You can adjust the channel level within the range of -15 ~ +15 dB.

■Note :

- The test tone will not be output from the speakers set to "NO".

5. To cancel the test tone function, press the RETURN button.

- The previous menu will be returned.

■When selecting the SPEAKER DISTANCE

1. Press the CURSOR UP/DOWN buttons to select the “DISTANCE”, then press the OK button.

- Then “L ~” will be displayed.

2. Press the CURSOR UP/DOWN buttons to select the desired speaker.

■Note :

- You cannot select the speakers set to “NO”.

3. Press the CURSOR LEFT/RIGHT buttons to set the selected speakers as desired.

- You cannot set the distance within the range of 0.1 ~ 9.0 meters in 0.1 meter intervals.

4. Repeat the above steps 2 and 3 until the distances are all set as desired.

■About the speaker distance

When enjoying multi-channel surround playback with Dolby Digital and DTS sources, etc., it is ideal that the center, surround, surround back and subwoofer speakers should be the same distance from the main listening position as the front speakers.

By entering the distance between the listening position and each speaker, the delay times of center, surround, surround back and subwoofer speakers are automatically adjusted to create an ideal listening environment virtually as if the center, surround, surround back and subwoofer speakers were at their ideal locations respectively.

Setting the Tone

- You can adjust the tone (bass and treble) as desired.

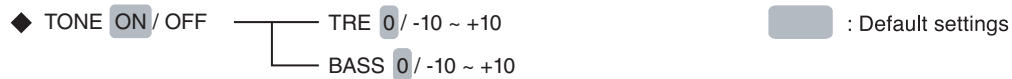

- Press the CURSOR LEFT/RIGHT buttons to set the tone mode as desired.

OFF : To listen to a program source without the tone effect.

↓

ON : To adjust the tone for your taste.

■When the TONE CONTROL is set to ON to adjust the tone (bass and treble)

- ①. Press the OK button to enter the tone adjustment mode.
 - Then “TRE ~” will be displayed.
- ②. Press the CURSOR UP/DOWN buttons to select the desired tone mode.
- ③. Press the CURSOR LEFT/RIGHT buttons to adjust the selected tone as desired.
 - The tone level can be adjusted within the range of -10 ~ +10 dB.
 - In general, we recommend the bass and treble to be adjusted to 0 dB (flat level).
 - Extreme settings at high volume may damage your speakers.
 - To complete tone adjustment, repeat the above steps ② and ③.







Operation of BD player

ENGLISH

PRELIMINARY KNOWLEDGE ABOUT DISCS

Playable disc types

This unit supports the following discs.

Type	Logo	Playable format/mode
BD-ROM BD-RE/BD-R		BDMV, AVCHD
DVD Video		DVD-Video
DVD-R		DVD-Video, AVCHD
DVD-RW		DVD-Video, AVCHD
Audio CD		Audio CD (CD-DA)
CD-R		Audio CD (CD-DA), MP3, WMA, JPEG, AVI, WMV
CD-RW		Audio CD (CD-DA), MP3, WMA, JPEG, AVI, WMV

- Only BD-RE/-R, DVD-R/-RW and CD-R/-RW discs recorded with UDF or ISO9660 format can be played back.
- This unit supports Ver 2.0 BD-ROM, Ver 3.0 BD-RE and Ver 2.0 BD-R.

■Notes :

- Unfinalized BD-RE/-R, DVD-R/-RW and CD-R/-RW discs can not be played back.
- Some 8 cm BD-REs/8 cm BD-Rs cannot be played on this unit.
- When a BD-Java title is played, loading may take longer than a normal title, or some functions may perform slowly.

■Unplayable discs

- Since this unit cannot support disc types, formats and file types not listed above, do not play such discs.
 - Some BD-RE/BD-R, DVD-RWs/DVD-Rs or CD-Rs/CD-RWs cannot be played due to incomplete disc finalization, recording quality or physical condition of the disc, characteristics of recording device or authoring software, etc.
- See the operating instructions supplied with your recording device for more information.

■Color system format

- Depending on the countries, this unit conforms to either the NTSC color system for U.S.A, Canada, etc. or the PAL for Europe, Australia, China, etc.









Region code

- Blu-ray Disc player and BD-ROM or DVD Video discs are assigned region codes according to the region in which they are sold. If the region codes do not match, the disc will not play.

Blu-ray Disc Region Code	Area
A	North America, Central America, South America, Korea, Japan, Taiwan, Hong Kong and South East Asia
B	Europe, Greenland, French territories, Middle East, Africa, Australia and New Zealand
C	India, China, Russia, Central and South Asia
A, B and C	All areas

DVD Region Code	Area
1	North America
2	Europe, Japan, Middle East, Egypt, South Africa, Greenland
3	Taiwan, Korea, the Philippines, Indonesia, Hong Kong
4	Mexico, South America, Central America, Australia, New Zealand, Pacific Islands, Caribbean
5	Russia, Eastern Europe, India, most of Africa, North Korea, Mongolia
6	China
ALL	All areas



Examples of playable discs :

	U.S.A.	Europe
BDs	  	 
DVDs	 	 

Notes on copyright

- Audio-visual material may consist of copyrighted works which must not be recorded without the authority of the owner of the copyright. Refer to relevant laws in your country.
- This product incorporates copyright protection technology that is protected by U.S. patents and other intellectual property rights. Use of this copyright protection technology must be authorized by Macrovision, and is intended for home and other limited viewing uses only unless otherwise authorized by Macrovision. Reverse engineering or disassembly is prohibited.

SYMBOL ABOUT INVALID OPERATION

- When you press a button, if the unit does not accept its operation,  appears on the TV screen. Operations are occasionally unacceptable even if  is not displayed.
- ※ Invalid operation may occur as expected if :
 - The region codes of the unit is different from that of the disc and playback will not be allowed.
 - The parental control works. (For details, refer to "SETTING THE PARENTAL CONTROL" on page 44.)
 - BD/DVD Video operations and functions may be different from the explanations in this manual and some operations may be prohibited due to disc manufacturer's settings.

PLAYABLE FILES

- Characters except "A~Z", "a~z", "0~9", " - " may be not displayed.
- This unit supports multi-session discs. Some multi-session discs may take a long time to load and some may not be loaded at all.

■ Notes :

- For some files, it may not be possible to use certain functions during playback.
- It may not be possible to play some files, even if they have the extension of a file playable on this player.
- Files protected by DRM (Digital Rights Management) cannot be played.

■ MP3 (".mp3")

- Sampling frequency : 44.1 kHz, 48 kHz.
- Bit rate : Up to 320 kbps.
- Fixed bit-rate files are recommended. Variable bit-rate (VBR) files are playable, but playing time may be displayed incorrectly.
- ID3 Tag is not available.
- MP3i and MP3 Pro are not available.

■ WMA (".wma")

- Sampling frequency : 44.1 kHz, 48 kHz.
- Bit rate : Up to 192 kbps.
- WMA Tag is not available.

■ JPEG (".jpg", ".jpeg")

- Maximum resolution : 4,272x2,848 pixels.
- JPEG format images stored in progressive format cannot be played back.

■ AVI (".avi")

- Playable codec : Xvid
- Maximum size of image : 1920 x 1080@30 fps

■ WMV (".wmv")

- Playable codec : WMV9
- Maximum size of image : 1920 x 1080@30 fps

CARE AND HANDLING OF DISCS

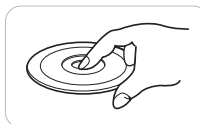

- In handling a disc, hold it carefully with edges.

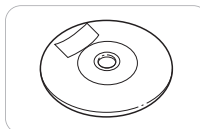

- Do not stick paper or write anything on the printed surface.



- Fingermarks and dust on the recorded surface should be carefully wiped off with a soft cloth. Wipe straight from the inside to the outside of the disc.

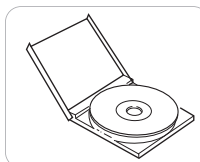

- Always keep the discs in their cases after use to protect them from dust and scratches.

- Do not use a cracked, deformed, or repaired disc. These discs are easily broken and may cause serious personal injury and apparatus malfunction.



■ Notes:

- Because the temperature inside this unit is very high, in case of no further playback of disc, unload the disc to prevent the high temperature from deforming the disc.
- Do not expose discs to direct sunlight, high humidity or high temperature for a long time.
- When loading or unloading a disc in the disc tray, always place it with the printed side up.

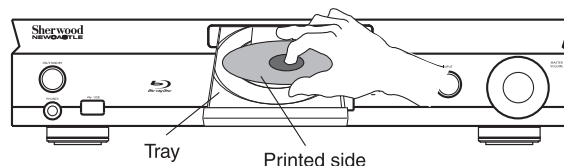

DEFINITION OF TERMS

AVCHD (Advanced Video Codec High Definition)

The AVCHD is a high definition(HD) digital video camera recorder format recording high-definition onto certain media by using highly efficient codec technologies.

- “AVCHD” and the “AVCHD” logo are trademarks of Panasonic Corporation and Sony Corporation.

BDAV

BDAV (Blu-ray Disc Audio/Visual, BD-AV) refers to one of the application formats used for writable Blu-ray discs such as BD-R, BD-RE, etc. BDAV is a recording format equivalent to DVD-VR (VR mode) of the DVD specifications.

BD-J application

The BD-ROM format supports Java for interactive functions. “BD-J” offers content providers almost unlimited functionality when creating interactive BD-ROM titles.

- Java and all Java-based trademarks and logos are trademarks or registered trademarks of Sun Microsystems, Inc. in the U.S. and other countries.

BD-LIVE

A variety of interactive content is available from BD-LIVE compatible Blu-ray discs via the internet.

- “BD-LIVE” logo is trademark of Blu-ray Disc Association.

BDMV

BDMV (Blu-ray Disc Movie, BD-MV) refers to one of the application formats used for BD-ROM which is one of the Blu-ray Disc specifications. BDMV is a recording format equivalent to DVD-video of the DVD specification.

BD-R

A BD-R (Blu-ray Disc Recordable) is a recordable, write-once Blu-ray Disc. Since contents can be recorded and cannot be overwritten, a BD-R can be used to archive data or for storing and distributing video material.

BD-RE

A BD-RE (Blu-ray Disc Rewritable) is a recordable and rewritable Blu-ray Disc.

BD-ROM

BD-ROMs (Blu-ray Disc Read-Only Memory) are commercially produced discs. Other than conventional movie and video contents, these discs have enhanced features such as interactive content, menu operations using pop-up menus, selection of subtitle display, and slide shows. Although a BD-ROM may contain any form of data, most BD-ROM discs will contain movies in High Definition format for playback on Blu-ray Disc players.

Blu-ray Disc (BD)

A disc format developed for recording/playing high-definition (HD) video (for HDTV, etc.), and for storing large amounts of data. A single layer Blu-ray Disc holds up to 25 GB, and a dual-layer Blu-ray Disc holds up to 50 GB of data.

- “Blu-ray Disc”, “Blu-ray” and “Blu-ray Disc” logo are trademarks of Blu-ray Disc Association.

BonusView

Some BD-ROMs have bonus contents and other data that can be downloaded to the external memory(local storage) for enjoyment.

- “BONUSVIEW” is trademark of Blu-ray Disc Association.

Dolby Digital

A sound system developed by Dolby Laboratories Inc. that gives movie theater ambience to audio output when the product is connected to a Dolby Digital processor or amplifier.

Dolby Digital Plus

A sound system developed as an extension to Dolby Digital. This audio coding technology supports 7.1 multi-channel surround sound.

Dolby TrueHD

Dolby TrueHD is a lossless coding technology that supports up to 8 channels of multi-channel surround sound for the next generation optical discs. The reproduced sound is true to the original source bit-for-bit.

- Manufactured under license from Dolby Laboratories. Dolby and the double-D symbol are trademarks of Dolby Laboratories.

DTS

This is a digital sound system developed by DTS, Inc. for use in cinemas.

DTS-HD High Resolution Audio

DTS-HD High Resolution Audio is a new technology developed for the next generation high definition optical disc format.

DTS-HD Master Audio

DTS-HD Master Audio is a lossless audio compression technology developed for the next generation high definition optical disc format.

- Manufactured under license under U.S. Patent #'s: 5,451,942; 5,956,674; 5,974,380; 5,978,762; 6,226,616; 6,487,535; 7,212,872; 7,333,929; 7,392,195; 7,272,567 & other U.S. and worldwide patents issued & pending. DTS and the Symbol are registered trademarks, & DTS-HD, DTS-HD Master Audio, and the DTS logos are trademarks of DTS, Inc. Product includes software.© DTS, Inc. All Rights Reserved.

DVD Video

A disc format for storing MPEG-2 video on DVD, with interactive menus, multiple soundtracks, subtitles, camera angles, and so on.

-  is a trademark of DVD format/Logo licensing Corporation.

DVD-R

A DVD-R is a recordable, write-once DVD.

DVD-RW

A DVD-RW is a recordable and rewritable DVD. The DVD-R/-RW has two different formats: VR format and Video format. DVDs created in Video format have the same format as a DVD video, while discs created in VR (Video Recording) format allow the contents to be programmed or edited.

HDMI

HDMI (High Definition Multimedia Interface) is a new connection format that supports both video and audio on a single digital connection.

The HDMI connection carries uncompressed, standard or high definition digital video signals and multi-channel audio signals to AV components such as HDMI equipped TVs, in digital form without degradation.

- HDMI, the HDMI logo and High-Definition Multimedia Interface are trademarks or registered trademarks of HDMI Licensing LLC.

Interlace format

Interlace format shows every other line of an image as a single "field" and is the standard method for displaying images on television. The even numbered field shows the even numbered lines of an image, and the odd numbered field shows the odd numbered lines of an image.

JPEG (Joint Photographic Experts Group)

JPEG is a popular file format for still image compression and storage.

Linear PCM

Linear PCM is a signal recording format used for Audio CDs and on some DVD and Blu-ray discs. The sound on Audio CDs is recorded at 44.1 kHz with 16 bits. (Sound is recorded between 48 kHz with 16 bits and 96 kHz with 24 bits on DVD video discs and between 48 kHz with 16 bits and 192 kHz with 24 bits on BD video discs.)

MPEG-2

MPEG-2 (Moving Picture Experts Group phase 2) is one of the video data compression schemes, which is adopted for DVD videos and digital broadcasts worldwide. Some Blu-ray Discs also use high bitrate MPEG-2.

MP3

MP3 is an audio data compression format, which stands for MPEG-1 Audio Layer 3. Using MP3, you can achieve a data reduction of about 1:10.

- MPEG Layer-3 audio coding technology licensed from Fraunhofer IIS and Thomson.

Multi Angle

This is a feature of DVD and BD video discs. In some discs, the same scene is shot from different angles, and these are stored in a single disc so you can enjoy playback from each angle.

Multi Audio

This is a feature of DVD and BD video discs. This function makes it possible to record different audio tracks for the same video, so you can enhance your enjoyment by switching the audio.

Pop-up menu

An enhanced menu operation available on BD video discs. The pop-up menu appears when **POPUP MENU** is pressed during playback, and can be operated while playback is in progress.

Progressive format

Compared to the Interlace format that alternately shows every other line of an image (field) to create one frame, the Progressive format shows the entire image at once as a single frame. This means that while the Interlace format can show 30 frames/60 fields in one second, the Progressive format can show 60 frames in one second. The overall picture quality increases and still images, text, and horizontal lines appear sharper.

Subtitle

These are the lines of text appearing at the bottom of the screen which translate or transcribe the dialog. They are recorded on many DVD and BD video discs.

WMA (Windows Media™ Audio)

WMA is an audio data compression format developed by Microsoft Corporation. WMA file size is smaller than that of MP3.

WMV (Windows Media™ Video)

WMV is a video data compression format by Microsoft Corporation.

- Windows Media and the Windows logo are trademarks or registered trademarks of Microsoft Corporation in the United States and/or other countries.

BD/DVD Video structure

BD/DVD Video discs typically one or more titles, which may be subdivided into chapters.

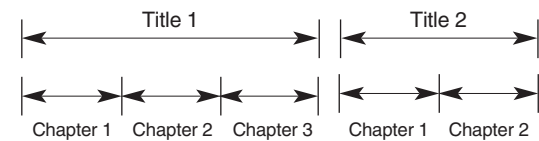

Audio CD

Audio CDs contain tracks.

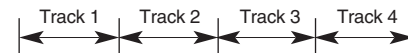

MP3/WMA/JPEG/AVI/WMV structure

On an MP3/WMA/JPEG/AVI/WMV disc, a folder can be a member of another folder, creating hierarchical folder layers. If you are familiar with a personal computer, you may easily understand the hierarchical file/folder construction.

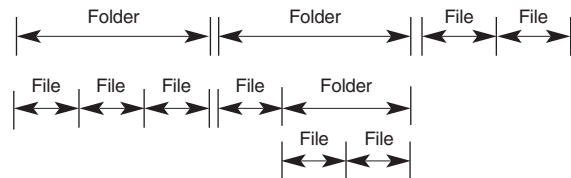

Before starting playback

- First set this unit as desired for optimum performance, doing the system setting procedures. (For details, refer to "OSD Menu Settings" on page 40.)
- For explanation purposes, this instructions explains the OSD(On-Screen Display) language displayed on TV in English.
- Usable discs and files for each operation/function are referred to by the icons :



VIDEO means AVI and WMV files.

PLAYING A DISC

Preparations

- Turn on the TV and select the video input source connected to this unit.

1. Select BD/DVD as input source.

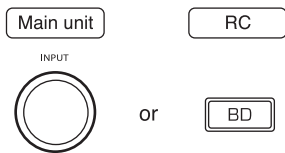

2. Open the disc tray to load a disc with the printed side up.



- 8 cm (3 inch) discs can be loaded on the inside circle of the tray, too.
- Depending on the disc types, it may take times to read the loaded disc.
- Then the main menu will be displayed on the TV screen.

Example :

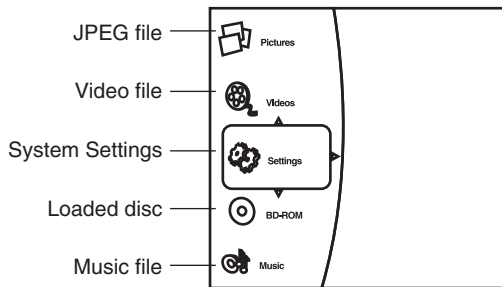

- When the Optical Disc AutoPlay is set to On (default setting), playback will automatically start. (For details, refer to "Optical Disc AutoPlay" on page 41.) Should this happen, ignore the step 3.

3. Press the CURSOR UP/DOWN buttons to select the disc, then press the OK button. (When the Optical Disc AutoPlay is set to Off.)

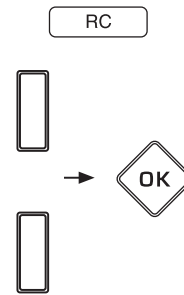

- Then playback will start.
- For some discs, the menu may be displayed first.

To start playback from the menu



- To select the preferred item, press the CURSOR buttons and press the OK button or press the NUMERIC buttons.

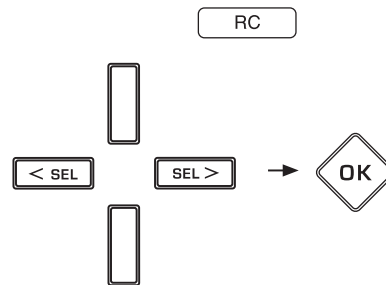

In case of use of the NUMERIC buttons on the remote control

- When selecting "3" :
- When selecting "10" : →
- When selecting "21" : →
- Playback of the selected item starts.
- When the selected item contains the subitems, repeat the above step until the preferred item is selected.
- Depending on the disc, the contents of the menu and the way to operate differ.

To stop playback **BD DVD-V AVCHD CD**

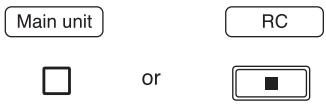

- When the STOP (■) button is pressed during playback of BD Video, DVD Video or AVCHD discs, the point at which the disc was stopped is stored in the memory. (RESUME function : "Stop" mode.)
- Press the PLAY/PAUSE (▶/||) button again, then playback will resume from this point. When the STOP (■) button is pressed again, the RESUME function will be canceled and it enters "FullStop" mode.

■ Note :
 • For some BD Video discs which support Java applications, the RESUME function will not work.

To pause playback **BD DVD-V AVCHD CD**

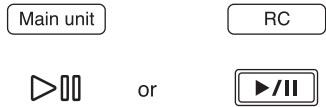

- Then the unit will be in the "Pause" mode.
- To return to normal playback mode, press this button again.

Slow playback **BD DVD-V AVCHD**

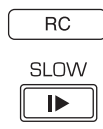

- Each time the SLOW (▶|) button is pressed, you can play back the disc slowly at 3 step speeds.
 → Slow x 1/2 → Slow x 1/4 → Slow x 1/8
- To return to normal playback, press the PLAY/PAUSE (▶/||) button.

Frame advance playback **BD DVD-V AVCHD**



- Each time the STEP (▶|) button is pressed, the disc is advanced by one frame.
- To return to normal playback, press the PLAY/PAUSE (▶/||) button.

To skip ahead or back **BD DVD-V AVCHD CD**

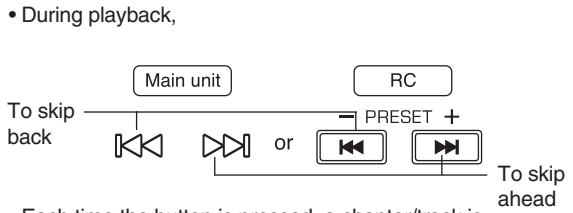

- During playback,
- Each time the button is pressed, a chapter/track is skipped.
- When the BACKWARD SKIP (◀◀) button is pressed once midway through a chapter/track, playback returns to the beginning of that chapter/track. When it is pressed again, a chapter/track is skipped.

Rapid playback **BD DVD-V AVCHD CD**

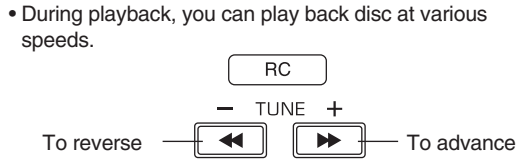

- During playback, you can play back disc at various speeds.
 → Fast x 2 → x 4 → x 8 → x 16 → x 32 → x 64 → x128
- Each time the button is pressed, the disc is advanced or reversed fast at 7 step speeds.
- To return to normal playback, press the PLAY/PAUSE (▶/||) button.

ENGLISH

Displaying disc information BD DVD-V AVCHD CD

- During playback,

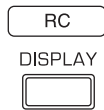

- Then the disc information is displayed on the TV screen.

Example : During playback of CD

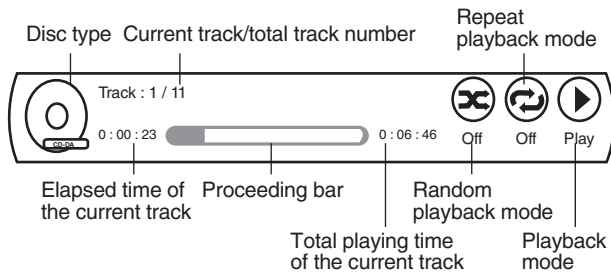

- To turn off the information, press this button.
- Depending on the disc types, the disc information differs.

Playing the desired section of disc BD DVD-V AVCHD CD

1. During playback, press the GO TO button.



- Then the search mode is displayed on the TV screen for several seconds.
- Each time this button is pressed, the search mode is changed depending on the disc types as follows :

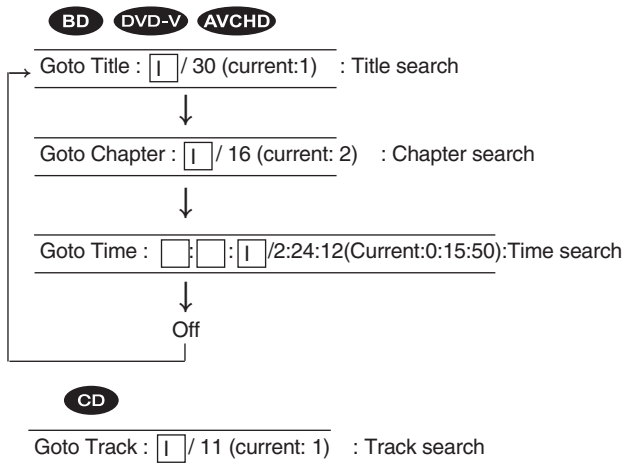

2. At the desired search mode, enter the number to be played, pressing the NUMERIC buttons.

■When entering title, chapter, track number

Examples :



■When entering the elapsed time

You can play a disc from the desired by specifying the elapsed time from the beginning of the current title/disc.

Examples :

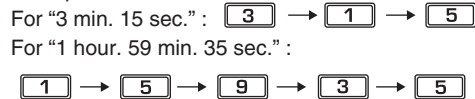

■When clearing the numbers entered

- Press the CURSOR LEFT/RIGHT buttons to select the number to be cleared, then press the CLEAR button.



- Then the selected number will be cleared.

3. Press the OK button.



- Then playback will start from the selected section.

■Notes:

- If the disc does not contain the number you entered, search playback will not work.
- Depending on the disc, search playback will not work or may work differently.

Playing repeatedly **BD DVD-V AVCHD CD**

- You can play a current title, chapter, disc or track repeatedly.
- During playback of the desired chapter/track, press the REPEAT button.

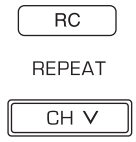

- Each time this button is pressed, the repeat mode changes depending on the disc types as follows :

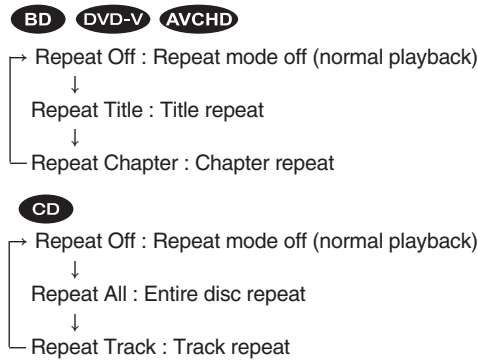

- Note :**
- For some BD Video discs which support Java applications, the repeat playback will not work.

Playing a specific section repeatedly

BD DVD-V AVCHD CD

- You can play a specific section within a title or track repeatedly.

1. During playback at the beginning of the section, press the REPEAT A-B button.

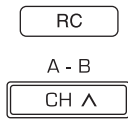

- Then "Repeat A-" is displayed on the TV screen.

2. At the end of the section, press the REPEAT A-B button again.

- Then "Repeat A-B" is displayed and the section between points A and B is played back repeatedly.
- To return to normal playback, press the REPEAT A-B button repeatedly until "Repeat Off" is displayed.

- Note :**
- For some BD Video discs which support Java applications, the REPEAT A-B function will not work.

Playing in random order **CD**

- You can play the tracks in random order.
- During playback, press the RANDOM button.

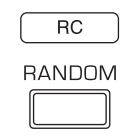

- Each time this button is pressed, the random mode changes as follows :

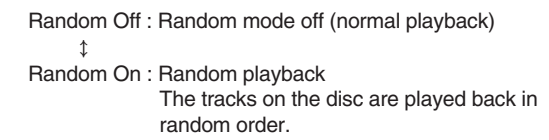

Operations using disc menu, top menu, and Pop-up menu

Many of BD Video and DVD Video disc contains disc menu, top menu or pop-up menu which guides you through the available functions in the disc.

- Note :**
- Contents of menus and corresponding menu operations may vary among discs. (For details, refer to the disc manual.)

Using the disc menu. **BD DVD-V AVCHD**

1. During playback, press the disc menu.



- Then the disc menu is displayed on the TV screen if present on the disc.

2. Press the CURSOR buttons to select the desired item, then press the OK button.

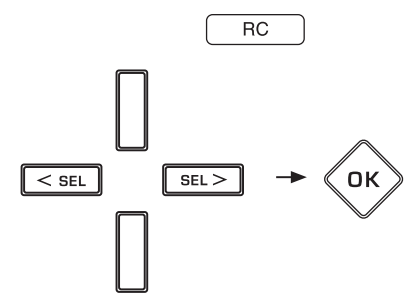

- Then the selected item is played back.

■Using the top menu. DVD-V AVCHD

1. During playback, press the POPUP MENU button.



- Then the top menu is displayed on the TV screen if present on the disc.

2. Press the CURSOR buttons to select the desired item, then press the OK button.

- Then the selected item is played back.

■Using the pop-up menu. BD

- This is a special feature available for some BD video. When you press the POPUP button, a menu pops out on the TV screen while the contents are still played back.

1. During playback, press the POPUP MENU button.

- Then the pop-up menu is displayed if present on the disc.

2. Press the CURSOR buttons to select the desired item, then press the OK button.

- Then the selected item is played back.

3. Press the POPUP button to exit.

- The pop-up menu will automatically disappear for some discs.

Switching the audio soundtrack

BD DVD-V AVCHD

For discs on which multiple audio streams are recorded, audio streams can be switched during playback. Also use this procedure to switch the secondary audio for BD video on which secondary audio is recorded.

- It is possible to change the audio language to a different language from the selected one at the OSD Menu Settings. (For details, refer to "SETTING THE LANGUAGE" on page 43.)

1. During playback, press the AUDIO button.

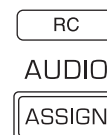

- Then the audio stream information is displayed for several seconds.

Example : BD Videos on which secondary audio is recorded.
Current audio stream/total number of recorded audio streams

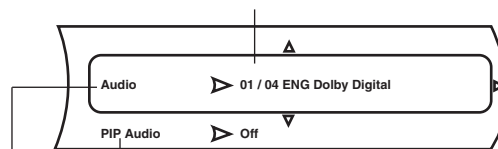

Secondary audio : Only selectable for BD Videos on which secondary audio is recorded.

(Primary) audio

2. Press the CURSOR RIGHT button.

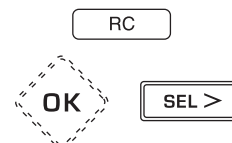

- Then the audio stream menu is displayed.
- To switch the secondary audio, press the CURSOR UP/DOWN buttons to select the PIP Audio, then press the CURSOR RIGHT button.

3. Press the CURSOR UP/DOWN buttons to select the desired audio stream, then press the OK button.

- Then the selected audio stream will be switched.
- Note:
 - When the primary and the secondary audio streams are all switched, they will be mixed and heard together. If confused, set the PIP Audio to Off to switch off the secondary audio stream.

Switching the subtitles BD DVD-V AVCHD

For discs on which multiple subtitles are recorded, the subtitles can be switched during playback. Also use this procedure to switch the secondary subtitle for BD Video on which secondary subtitle is recorded.

- It is possible to change the subtitle language to a different language from the selected one at the OSD Menu Settings. (For details, refer to “SETTING THE LANGUAGE” on page 43.)

1. During playback, press the SUBTITLE button.

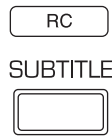

- Then the subtitle information is displayed for several seconds.

Example : BD Videos on which secondary subtitle is recorded.

Current subtitle/total number of recorded subtitles

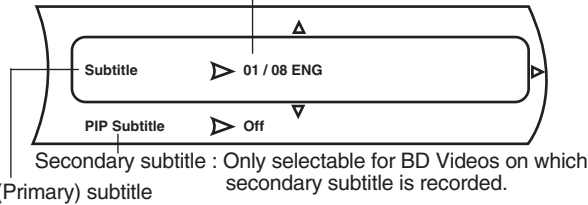

2. Press the CURSOR RIGHT button.

- Then the subtitle menu is displayed.
- To switch the secondary subtitle, press the CURSOR UP/DOWN buttons to select the PIP Subtitle, then press the CURSOR RIGHT button.

3. Press the CURSOR UP/DOWN buttons to select the desired subtitle, then press the OK button.

- Then the selected subtitle will be displayed.
- To switch off the subtitle, select the Off.

■ Note:

- When the primary and the secondary subtitles are all switched, both will be displayed on the TV screen. If confused, set either of subtitles to Off.

Switching the camera angles BD DVD-V

- For discs on which multiple angles are recorded, the angles can be switched during playback.

■ Note:

- You can switch the camera angle at only the scene that have been shot simultaneously from multiple camera angles.

1. During playback at the scene recorded from multiple camera angles, press the ANGLE button.

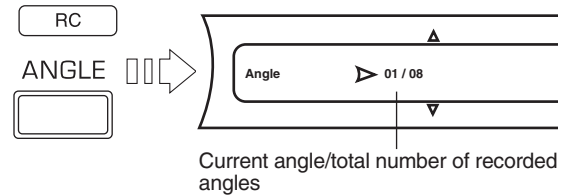

- Then the angle information is displayed for several seconds.

2. Press the CURSOR RIGHT button.

- Then the angle menu is displayed.

3. Press the CURSOR UP/DOWN buttons to select the desired angle, then press the OK button.

- Then the scene recorded from the selected angle will be displayed.

ENJOYING BONUSVIEW OR BD-LIVE

This unit is compatible with additional functions of BD Video, BONUSVIEW (BD-ROM Profile 2.0) and BD-LIVE. For BD Video discs compatible with BONUSVIEW, the functions of Picture in Picture and Virtual Package are available.

For BD-LIVE compatible discs, you can enjoy a variety of functions via the internet in addition to the BONUSVIEW functions.

Virtual Package/BD-LIVE data is saved in Local Storage (USB memory device connected to this unit).

To enjoy these functions, connect a USB memory device (minimum 1 GB capacity (2 GB or more recommended)) supporting FAT 32 and USB 2.0 High Speed (480 Mbit/s) to the USB connector. (For details, refer to "USB CONNECTOR" on page 10.)

- If there is insufficient storage space, the data will not be copied/downloaded. Delete unneeded contents or use a new USB memory device.
- If a USB memory device containing other contents (previously recorded) is used, the video and audio may not play back properly.
- If the USB memory device is disconnected from this unit during playback of Virtual Package/BD-LIVE contents, playback of the disc will stop.
- Some time may be required for the contents to load (read/write).

■Notes :

- It may not be possible to use the BD-LIVE functions if there is insufficient space on the USB memory device. In this case, refer to "Erase Blu-ray Storage?" on page 41 for erasing the Virtual Package contents and the BD-LIVE contents in the USB memory device.
- Operation of USB memory devices is not guaranteed.
- Do not use a USB extension cable when connecting a USB memory device to the USB connector.

Playing secondary video(Picture in Picture)

BD Video that includes secondary video and audio compatible with Picture in Picture can be played back with secondary video and audio simultaneously as a small video in the corner.

- To listen to secondary audio or to display secondary subtitle, refer to "Switching the audio soundtrack" on page 32 or "Switching the subtitles" on page 33.

■Note :

- You can call up the secondary video at only the scene that contains the secondary video. (For details on PIP function of your disc, refer to the disc manual.)

1. During playback at the scene that contains the secondary video, press the PIP button.

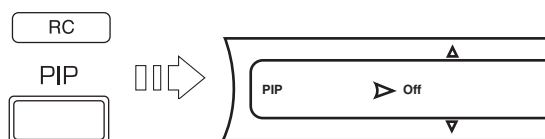

- Then the PIP setting menu is displayed for several seconds on the TV screen.

2. Press the CURSOR RIGHT button to enter the PIP mode menu.

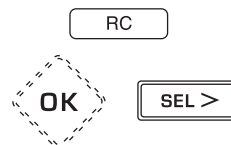

3. Press the CURSOR UP/DOWN buttons to select the secondary video, then press the OK button.

- Then the secondary video will be displayed.

Example :

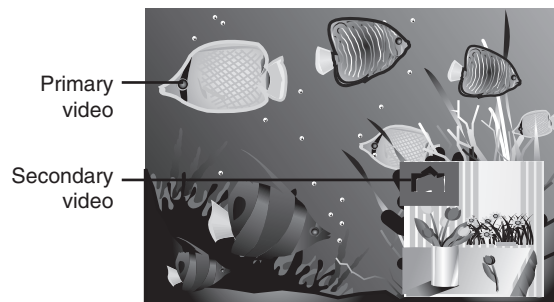

Virtual Package

For BD Video discs compatible with Virtual Package, contents are copied from the discs or internet to local storage. It is automatically copied to the local storage prior to playback. You can enjoy a variety of additional functions including secondary video, secondary audio, subtitles, movie trailer, etc.

- The playback methods vary depending on the disc. (For details, refer to the disc manual.)

BD-LIVE

In this unit, a variety of contents with interactive functions are available through BD-LIVE compatible BD discs by connecting to the internet. You can enjoy the download of bonus features such as latest movie trailers to the USB memory device, communication compatible BD-J interactive games, etc.

- The available functions differ depending on the disc.

■Notes :

- Regarding playback method of BD-LIVE contents, etc., perform the operations in accordance with the instructions in the BD disc manual.
- To enjoy BD-LIVE functions, perform the broadband internet connection and communication settings. (For details, refer to "CONNECTING TO NETWORK" on page 9 and "SETTING THE NETWORK" on page 45.)
- Regarding the setup to restrict access to BD-LIVE contents, refer to "BD-Live Internet Access" on page 41.)

PLAYING FILES **MP3** **WMA** **JPEG** **VIDEO**

• You can play music files such as MP3 and WMA, picture files such as JPEG and video files such as AVI and WMV recorded onto a CD-R/-RW or a USB memory device.

1. In the stop mode, load a disc or insert a USB memory into the USB connector.

• Then the music and picture file symbols, etc are displayed on the main menu.

Example : When a USB memory is inserted.

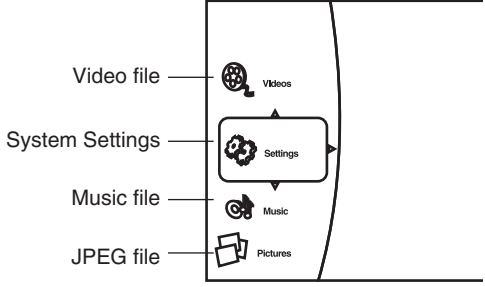

2. CURSOR UP/DOWN buttons to select the type of file to be played, then press the CURSOR RIGHT button.

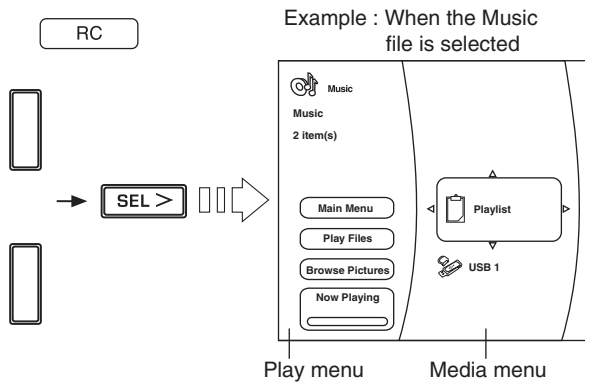

• Then the play menu of the selected type of file is displayed.

3. Press the CURSOR buttons to select the desired media in the media menu, then press the CURSOR RIGHT button.

• Then the folder and files recorded onto the selected media are displayed.

- Notes:**
- Even if a CD-R/CD-RW or a USB memory device contains a mix of music, picture and video files, you will only be able to browse the selected type of files (music, picture or video).
 - When there are no files to be played onto the selected media or folder, " ⊗ Empty " will be displayed.
 - This unit does not support the subtitle function for video files.

4. Select the desired file using the CURSOR buttons, then press the OK button or the CURSOR RIGHT button.

• Then the corresponding dialog box is displayed depending on whether the Playlist is selected as a media or not as follows.

• When selecting the Playlist • When selecting the Optical Disc or the USB 1

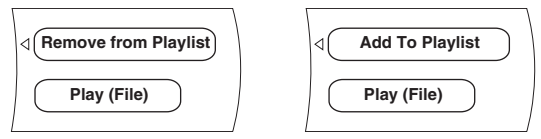

Note:
• When the JPEG file is selected as a type of file to be played, the "Play(File)" cannot be selected.

5. Press the CURSOR UP/DOWN buttons to select the desired item in the dialog box, then press the OK button.

When selecting the "Remove from Playlist"

- The selected file is cleared in the playlist.
- Repeat the above steps 4 and 5 until other files are cleared.

When selecting the "Add To Playlist"

- The selected file is added in the playlist.
- Repeat the above steps 4 and 5 until other files are added.

Note :

- When a disc is unloaded or the USB memory is disconnected, the files are all cleared in the playlist.

When selecting the "Play (File)"

- Only the selected file will be played (and the file information will be displayed on the TV screen when playing a music file).

Example : When playing a music file

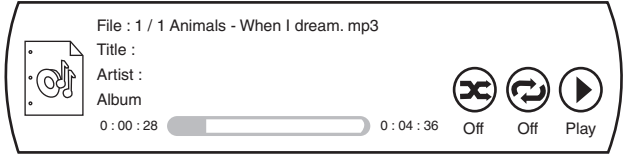

Note:

- To play JPEG files, select the "Play Files" in the play menu.

Selecting an item in the play menu

MP3 WMA JPEG VIDEO

- The items listed in the play menu may vary depending on the operation status and the selected media, etc.

■Note:

- During playback of file, press the STOP (■) button (or the HOME MENU button) to display the play menu, etc.
- In the stop mode, press the CURSOR UP/DOWN buttons to select an item in the play menu, then press the OK button.

■When selecting the “Main Menu”

- The main menu will be returned to.

■When selecting the “Play Files”

- Press the CURSOR UP/DOWN buttons to select the desired play mode in the play menu, then press the OK button. Then playback will start according to the selected play mode.

■Notes:

- When playing JPEG files, each file is displayed for the time interval you specified.
- The selectable play mode may vary depending on the operation status and the selected media, etc.

■When selecting the “Browse Pictures” or the “Browse Music”

- The JPEG file or the music file will be changed to as the type of file to be played.

■When selecting the “Add all to playlist”

- All the files are added in the playlist.

■When selecting the “Remove all from playlist”

- All the files are cleared in the playlist.

■When selecting the “Previous folder”

- Each time this item is selected, the previous folder or the previous menu will be returned to.

■When selecting the “Now Playing”

- The playback status for music files is displayed.

To stop playback

MP3 WMA JPEG VIDEO

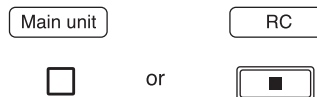

- Then the playback will be stopped and the play mode, etc. will be displayed.

To pause playback

MP3 WMA JPEG VIDEO

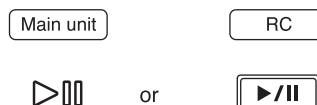

- Then the unit will be in “Pause” mode.
- To return to normal playback mode, press this button again.

Slow playback

VIDEO



- Each time the SLOW (▶) button is pressed, you can play back the video files slowly at 3 step speeds.

→ Slow x 1/2 → Slow x 1/4 → Slow x 1/8

- To return to normal playback, press the PLAY/PAUSE (▶/||) button.

To specify the time interval

JPEG

- During playback,



- Each time the SLOW (▶) button is pressed, you can specify the time interval to display the JPEG file as follows :

→ 5 seconds → 10 → 15 → 30

Frame advance playback **VIDEO**



- Each time the STEP (II) button is pressed, the video file is advanced by one frame.
- To return to normal playback, press the PLAY/PAUSE (▶/II) button.

To skip ahead or back **MP3 WMA JPEG VIDEO**

- During playback,

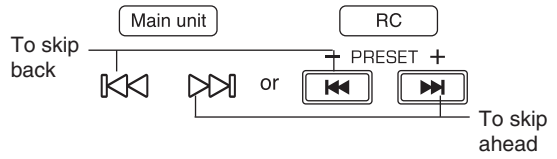

- Each time the button is pressed, a file is skipped.
- When the BACKWARD SKIP (◀◀) button is pressed once midway through a MP3/WMA/VIDEO file, playback returns to the beginning of that file. When it is pressed again, a file is skipped.

Rapid playback **MP3 WMA JPEG VIDEO**

- During playback, you can play back files at various speeds depending on the type of file as follows :

MP3 WMA VIDEO

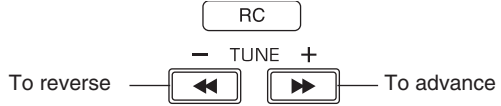

- Each time the button is pressed, the file is advanced or reversed fast at 7 step speeds.

→ Fast x2 → x4 → x8 → x16 → x32 → x64 → x128 →

- To return to normal playback, press the PLAY/PAUSE (▶/II) button.

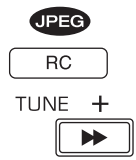

- Each time the FORWARD SEARCH (▶▶) button is pressed, the time interval to display is shortened as follows :

→ 5 seconds → 2 → 1 → No Delay →

Displaying file information **JPEG VIDEO**

- During playback,

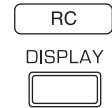

- Then the file information is displayed on the TV screen.

Example : During playback of video file.

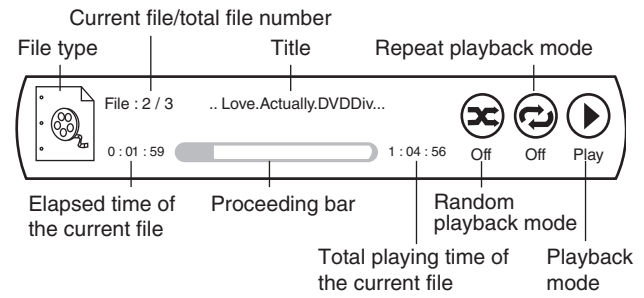

- To turn off the information, press this button.
- Depending on the file types, the file information differs.
- During playback of music files, the file information is still displayed without pressing this button.

Playing the desired section of file **MP3 WMA VIDEO**

1. During playback, press the GO TO button.

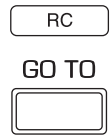

- Then the search mode is displayed on the TV screen for several seconds.
- Each time this button is pressed, the search mode is changed as follows :

Goto File : / 81 (current: 1) : File search



Goto Time : : : / 0:02:29 (Current: 0:00:39) : Time search

2. At the desired search mode, enter the number to be played, pressing the NUMERIC buttons.

■ When entering file number

- Examples :
- For "3" : 3
 - For "11" : 1 → 1

Continued

■ When entering the elapsed time

You can play from the desired by specifying the elapsed time from the beginning of the current file.

Examples :

For "3 min, 15 sec." : → →

For "1 hour, 59 min, 35 sec." :

→ → → →

■ When clearing the number entered

- Press the CURSOR LEFT/RIGHT buttons to select the number to be cleared, then press the CLEAR button.



3. Press the OK button.



- Then the playback will start from the selected section.

■ Notes :

- If the media does not contain the number you entered, search playback will not work.
- Depending on the files, search playback will not work or may work differently.

Playing repeatedly **MP3** **WMA** **JPEG** **VIDEO**

- You can play a current file or all files repeatedly.
- During playback of the desired file, press the REPEAT button.

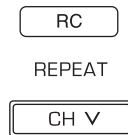

- Each time this button is pressed, the repeat mode changes depending on the file types as follows :

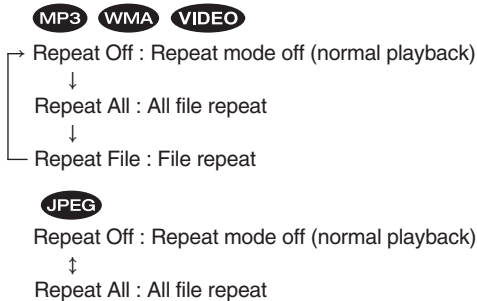

Playing in random order **MP3** **WMA** **VIDEO**

- You can play the files in random order.
- During playback, press the RANDOM button.

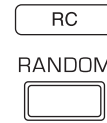

- Each time this button is pressed, the random mode changes as follows :

Random Off : Random mode off (normal playback)



Random On : Random playback

The files are played back in random order.

To change the effect on displaying pictures

JPEG

- You can display the JPEG files at the slide show options you select.

1. During playback, press the POPUP MENU button.

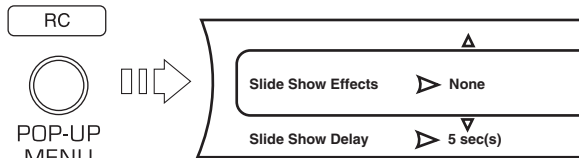

- Then the Slide Show menu is displayed for several seconds.

2. Press the CURSOR UP/DOWN buttons to select the desired item, then press the CURSOR RIGHT button.

- Then the selected item menu is displayed.

3. Press the CURSOR UP/DOWN buttons to select the desired option, then press the OK button.

■ When selecting the Slide Show Effects

- You can select the desired of different display modes as follows :

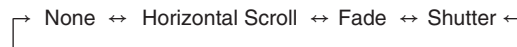

■ When selecting the Slide Show Delay

- You can select the desired of different time intervals to display the JPEG files as follows :

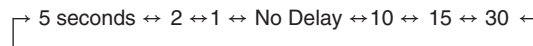

Playing both the music files and the JPEG files simultaneously **MP3 WMA JPEG**

- 1.** During playback of music files, press the OK button.

 - Then the play menu, etc are displayed.
- 2.** In the play menu, press the CURSOR UP/DOWN buttons to select the "Browse Pictures", then press the OK button.

 - Then you can browse the JPEG files to be played.
- 3.** Select the some JPEG files to be played and play them in the desired play mode.

- Then you can see the JPEG files while listening to the music files.
- While playing both the music files and the JPEG files, the playback controls are effective for the JPEG files only.

■ To control the music files

1. Press the STOP (■) button to stop the playback of the JPEG files.
 - Then the play menu, etc. will be displayed.
2. Press the CURSOR UP/DOWN buttons to select the "Now Playing" in the play menu, then press the OK button.
 - Then the music file information is displayed and you can control the music files.

OSD Menu Settings

- The OSD (On-Screen Display) menu enables various audio/visual settings and adjustments.

ENGLISH

1. In the stop mode, press CURSOR UP/DOWN buttons to select “Settings” in the main menu, then press the CURSOR RIGHT button.

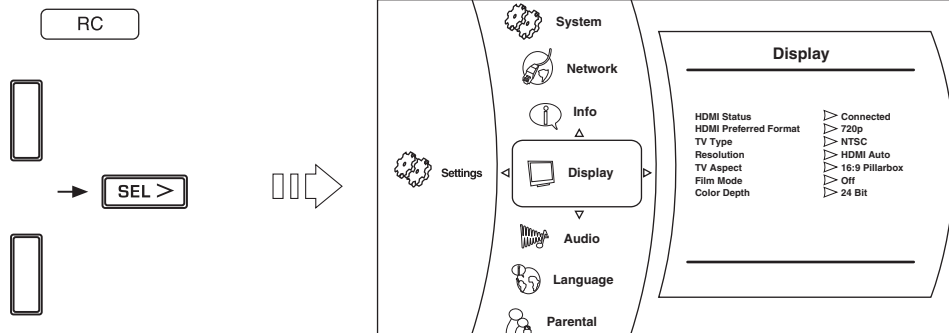

- During playback of BD Video, DVD Video or CD disc, if the STOP (■) button or the HOME MENU button is pressed, then the main menu will be displayed.
- During playback of music, JPEG or video files, if the HOME MENU button is pressed, then the previous menu will be displayed, in this case, if the HOME MENU button is pressed again, then the main menu is displayed.

2. Press the CURSOR UP/DOWN buttons to select the desired setting category, then press the CURSOR RIGHT button.

- You can select the desired of various setting categories as follows :

System : See “SETTING THE SYSTEM” on page 41.
 Network : See “SETTING THE NETWORK” on page 45.
 Info : You can check the system information on this unit.
 Display : See “SETTING THE DISPLAY” on page 42.
 Audio : See “SETTING THE AUDIO” on page 43.
 Language : See “SETTING THE LANGUAGE” on page 43.
 Parental : See “SETTING THE PARENTAL CONTROL” on page 44.

■ **Note :**

- Because the setting operation for Parental and Network differs, follow their own procedures.

3. Press the CURSOR UP/DOWN buttons to select the desired setting item, then press the CURSOR RIGHT button.

- Then the selected item's option menu will be displayed.

4. Press the CURSOR UP/DOWN buttons to select the desired option, then press the OK button to confirm your selection.

- Then the previous screen will be displayed.
- To go back to the previous screen, press the CURSOR LEFT button or the RETURN button.

SETTING THE SYSTEM

- For how to select the setting items and options, refer to “OSD Menu Settings” on page 40.
- Settings with* are the default.

Setting items	Options
<p>Optical Disc AutoPlay Set whether to automatically play a disc or not when loading it or turning on the Power under the condition that it is loaded.</p>	<p>On* : Starts play automatically. Off : Turns off the autoplay.</p>
<p>BD-Live Internet Access Set the access restriction to BD-LIVE contents</p>	<p>Limit Access : Allows only the BD disc with owner certification to access contents from a BD-LIVE website. Always Allow Access* : Allows all BD-LIVE discs to access contents from BD-LIVE websites. Prohibit Access : Prohibit all BD-LIVE discs from accessing contents from BD-LIVE websites.</p> <p>■Notes : • The available functions differ depending on the disc. • Regarding playback method of BD-LIVE contents, etc., perform the operations in accordance with the instructions in the BD-LIVE disc manual. • To enjoy BD-LIVE functions, perform the broadband internet connection and communication settings. (For details, refer to “CONNECTING TO NETWORK” on page 9 and “SETTING THE NETWORK” on page 45.)</p>
<p>BD-Live Storage (USB) BD-LIVE contents are stored into the USB memory device.</p>	<p>USB1 (~ GB Free) Displays the storable memory capacity.</p>
<p>Screen Saver Duration Set the period of time to activate screen saver function. A TV screen may be burned out if a static picture is displayed for a long time in the stop mode, etc.. To prevent this, the unit automatically activate the screen saver function if a static picture is displayed over the period of time you set.</p>	<p>Off : Inactivates screen saver function. 5*/10/20/30 Minutes Activates screen saver function if a static picture is displayed over the period of time you set.</p> <p>■Note : • To inactivate screen saver function, press any button.</p>
<p>Erase Blu-ray Storage? Erase the Virtual Package and BD-LIVE contents stored into the USB memory storage.</p>	<p>1. Perform the steps 1~3 in “OSD Menu Settings” procedure on page 40 to select “Erase Blu-ray Storage?” or “Reset Settings” on the system menu. 2. Press the OK button. Then the dialog window will be displayed. 3. Press the CURSOR LEFT/RIGHT buttons to select “OK”, then press the OK button.</p>
<p>Reset Settings Reset all settings to the factory default except the Parental settings, etc.</p>	

SETTING THE DISPLAY

ENGLISH

- For how to select the setting items and options, refer to “OSD Menu Settings” on page 40.
- Settings with* are the default.

Setting items	Options
<p>TV Type Set the video signal format depending on that of your TV and disc.</p>	<p>NTSC : Select this when the video signal format of your TV and the discs is NTSC color system for U.S.A., Canada, etc..</p> <p>PAL : Select this when the video signal format is PAL color system for Europe, Australia, China, etc..</p> <p>■ Note :</p> <ul style="list-style-type: none"> • If the color system of this unit is different from that of your TV and the discs, the screen may be somewhat hard too see or the picture quality may be poor. Only in this case, set the video signal format to another.
<p>Resolution Set the resolution of the Component and HDMI video signal</p>	<p>HDMI Auto* : HDMI video resolution will be selected automatically depending on the HDMI-compatible TV.</p> <p>1080p : Outputs 1080 lines of progressive video. 1080i : Outputs 1080 lines of interlaced video. 720p : Outputs 720 lines of progressive video. 480p : Outputs 480 lines(NTSC)(or 576 lines(PAL)) of progressive video. 480i : Outputs 480 lines(NTSC)(or 576 lines(PAL)) of interlaced video.</p> <ul style="list-style-type: none"> • For details on Resolution settings, refer to “Video output resolution” on page 6.
<p>TV Aspect Set the picture size according to aspect ratio of your TV</p>	<p>16:9 Wide* : Select this when a wide-screen TV is connected. Discs recorded in wide-screen format is played back over the entire TV screen.</p> <p>16:9 Pillarbox : When playing back 4:3 images, the picture is displayed in the center of the 16:9 screen with a 4:3 aspect ratio.</p> <p>4:3 Letterbox : Select this to play back the discs recorded in wide-screen format with 4:3 TV in the letter box mode (with black strips at the top and bottom).</p>
<p>Film Mode Set whether to output 1080/24p video signals from HDMI OUT when playing film-based materials (24 frame) on BD discs.</p>	<p>On : Select this to output 1080/24p video signals from HDMI OUT when playing film based materials (24 frame).</p> <p>Off* : Select this when playing a materials other than film based materials (24 frame).</p> <p>■ Notes :</p> <ul style="list-style-type: none"> • 1080/24p video signals cannot be output from video OUTs other than HDMI OUT. • 1080/24p video signals can be output when the following conditions are met. <ul style="list-style-type: none"> - HDMI OUT is connected to TV compatible with 1080/24p video signals. - Resolution is set to HDMI Auto or 1080p.
<p>Color Depth Set whether to output the HDMI video signal with the color depth effect or not.</p>	<p>36 Bit : Select this to output the HDMI video signal with the 36 Bit color depth to TV which supports 36 Bit HDMI deep color.</p> <p>30 Bit : Select this to output the HDMI video signal with the 30 Bit color depth.</p> <p>24 Bit* : Select this to output the HDMI video signal without the color depth effect to TV which does not support HDMI deep color.</p> <p>■ Notes :</p> <ul style="list-style-type: none"> • For details on HDMI deep color which TV supports, refer to the operating instructions of TV. • If color depth setting is different from that which TV supports, picture may flicker or be displayed abnormally. Should this happen, first make (composite) video connection between this unit and TV, and select the (composite) VIDEO as an input source on the TV to display the setting menu, then set the Color Depth correctly.

SETTING THE AUDIO

- For how to select the setting items and options, refer to “OSD Menu Settings” on page 40.
- Settings with* are the default.

Setting items	Options
<p>HDMI Output Set whether to output the digital audio signals from the HDMI OUT or not.</p>	<p>On (Auto) : To automatically convert the digital audio signals to the signal format acceptable for TV and to output them from the HDMI OUT, meaning these signals are heard from the speakers of your TV(, not the speakers connected to this unit.) Off* Speaker* : Not to output the digital audio signals from the HDMI OUT, meaning these signals are heard from the speakers connected to this unit.</p> <p>■ Notes : • When an Audio CD recorded in DTS-ES or Dolby Digital EX is played, no sound may be heard. • When the HDMI Output is set to On (Auto), some buttons related to the volume operation, etc. does not work, flickering “HDMI ONLY”.</p>
<p>Dynamic Range Control Set whether to compress the dynamic range between the loudest and softest sounds when Dolby Digital, Dolby Digital Plus or Dolby TrueHD audio is played back.</p>	<p>On : Turns on the dynamic range compression to hear low sounds easier. Off* : Turns it off. Auto : When Dolby TrueHD audio is played back, the dynamic range is automatically adjusted.</p>

SETTING THE LANGUAGE

- For how to select the setting items and options, refer to “OSD Menu Settings” on page 40.
- Settings with* are the default.

Setting items	Options
<p>OSD Set the language for unit’s OSD (On-Screen Display)</p>	<p>English*/French/Spanish/Italian/German/Russian</p>
<p>Menu Set the language for disc menu or pop-up menu.</p>	<p>Auto*: Selects the language given priority in the disc. English/French/Spanish/Italian/German/Portuguese/ - - - - - /Urdu/ Vietnamese/Yoruba</p>
<p>Audio Set the language for audio.</p>	<p>Auto*: Selects the language given priority in the disc. English/French/Spanish/Italian/German/Portuguese/ - - - - - /Urdu/ Vietnamese/Yoruba</p>
<p>Subtitle Set the language for subtitle.</p>	<p>Off* : Displays no subtitles. English/French/Spanish/Italian/German/Portuguese/ - - - - - /Urdu/ Vietnamese/Yoruba</p>

■ Notes :

- Depending on the discs, it may not be possible to change to the selected language.

SETTING THE PARENTAL CONTROL

The parental control allows you to set a limit, which prevents your children from viewing inappropriate materials. If the ratings exceed the levels you set, playback will be stopped, or inappropriate scenes such as violent scenes can be cut or replaced with other scenes depending on the disc type.

■Notes :

- When you set the Parental Level low, some discs may not be played at all, in this case, set the Parental Level higher or the parental control to Off.
- All discs may not respond to the Parental Level setting. Make sure this function works with your disc.

1. Perform the steps 1 and 2 in “OSD Menu Settings” procedure on page 40 to select the Parental.

- When the Parental Control is set to On, the parental password entry screen appears as follows.

- In this case, press the NUMERIC buttons to enter the 4-digit numbers, press the CURSOR buttons to select “OK” and press the OK button.
- Then the Parental menu will be displayed.

■Note :

- Do not forget the password. When you enter the password for the first time or if you forgot your password, enter “3308” as a factory setting.

2. Press the CURSOR UP/DOWN buttons to select the setting item, then press the CURSOR RIGHT button.

- Then the selected item’s option menu will be displayed.

When selecting the Parental Control or the Parental Level

■When selecting the Parental Control

Off* : Parental Control is inactive; all discs are played back.
On : Parental Control restricts playing discs according to parental level you set.

■When selecting the Parental Level

- 1 [Kid Safe]* : Suitable for children.
- 2 [G] : General audience.
- 3 [PG] : Parental guidance suggested.
- 4 [PG-13] : Unsuitable for children under 13.
- 5 [PG-R] : Parental guidance recommended.
- 6 [R] : Restricted; under 17 requires accompanying parent or adult guardian.
- 7 [NC-17] : No one under 17 admitted.
- 8 [Adult] : Discs of any grades (adult/general/children) can be played back.

- The lower the level value, the stricter the limitation.

3. Press the CURSOR UP/DOWN buttons to select the desired option, then press the OK button to confirm your selection.

- Then the previous screen will be displayed.

When selecting the Parental Password

- Then the new parental password entry screen appears.

3. Press the NUMERIC buttons to enter the new 4-digit numbers, press the CURSOR buttons to select “OK” and press the OK button.

- Then the parental password entry screen for confirmation appears.

4. Perform the above step 3.

- Then the new password will be changed to and the previous screen will be displayed.

SETTING THE NETWORK

- To access BD-LIVE contents from websites, you should connect this unit to the internet and set the communication settings. (For details, "CONNECTING TO NETWORK" on page 9.)
- When you set the communication setting manually, the following information of the connected router or modem is required. Confirm the information prior to the setting : IP address, Subnet mask, Gateway, Primary DNS and Secondary DNS.

1. Perform the steps 1 and 2 in "OSD Menu Settings" procedure on page 40 to select the Network.

- Then the network setting menu will be displayed.

Wired :

Configures network settings depending on your internet environment, etc. when connecting to the internet.

Network Test :

Detects the internet connection and automatically configures the network settings by the DHCP server function of the router or modem.

■ Note :

- When IP Mode is set to Off, Network Test cannot be selected.

2. Press the CURSOR UP/DOWN buttons to select the network configuration mode, then press the OK button.

- When selecting the Network Test, see page 46.

When selecting the Wired

Then the IP Settings menu will be displayed as follows :

IP Settings	
Link Status	▶ Link Up
MAC Address	00:23:03:00:50:b4
IP Mode	▶ Dynamic
IP Address	192.168.1.110
Subnet Mask	255.255.255.0
Gateway	192.168.1.1
Primary DNS	168.126.63.1
Secondary DNS	0.0.0.0
<input type="button" value="Apply"/> <input type="button" value="Cancel"/>	

3. Press the CURSOR RIGHT button to display the IP Mode.

Off:

Disables this unit's LAN capabilities.

Manual :

Configures network settings manually.

Dynamic (default setting) :

Automatically configures the network settings by the DHCP server function of the router or modem.

■ Note :

- Select the Manual only when the DHCP server function of the router or modem cannot be used for the automatic configuration.

4. Press the CURSOR UP/DOWN buttons to select the desired IP Mode, then press the OK button.

■ When selecting the Manual

- You can select IP Address, Subnet Mask, Gateway, Primary DNS and Secondary DNS to configure them manually.
- On the IP Settings menu, "Link Status" and "Mac Address" display the corresponding information merely.

- ① Press the CURSOR UP/DOWN buttons to select the desired option, then press the OK button. Then the New Value entry screen will be displayed.

Example : When selecting IP Address

Please enter a new IP Address.	
Valid range of each segment is 0 to 255.	
Current value	▶ 192.168.1.110
New Value	<input type="text"/> <input type="text"/> <input type="text"/> <input type="text"/>
▼	
<input type="button" value="OK"/> <input type="button" value="Cancel"/>	

- ② Enter the new value pressing the NUMERIC buttons, then press the CURSOR buttons to select "OK" and press the OK button.
- ③ Repeat the above steps ① and ② until other new values are all entered.

Continued

- 5.** Press the CURSOR UP/DOWN buttons to select “Apply”, then press the OK button.

■ When selecting the Manual or the Dynamic

- Then the network test is automatically performed and the result is displayed.
- Press the OK button to confirm the test result. Then the network information will be displayed.

■ When selecting the Off

- The values for IP Address, Subnet Mask, Gateway, Primary DNS and Secondary DNS are all cleared.

When selecting the Network Test

- Then the network test is automatically performed and the result is displayed.
- Press the OK button to confirm the test result. Then the network information will be displayed.

Operation of Tuner

LISTENING TO RADIO BROADCASTS

Auto tuning

1. Select the desired FM mode.

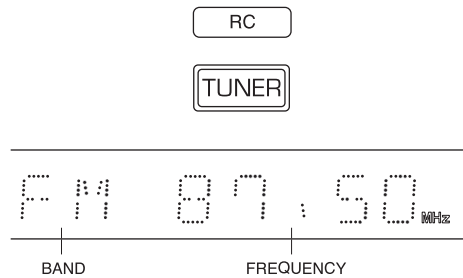

- Each time this button is pressed, the FM mode changes as follows :

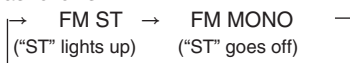

- When FM stereo broadcasts are poor because of weak broadcast signals, select the FM mono mode to reduce the noise, then FM broadcasts are reproduced in monaural sound.

2. Press the TUNING buttons for more than 0.5 second.

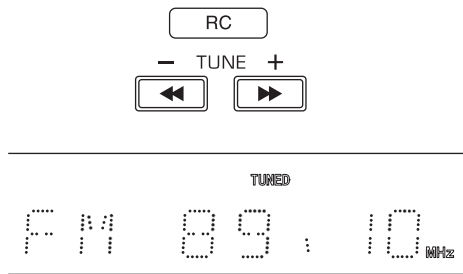

- The tuner will now search until a station of sufficient strength has been found. The display shows the tuned frequency and "TUNED".
- If the station found is not the desired one, simply repeat this operation.
- Weak stations are skipped during auto tuning.

Manual tuning

- Manual tuning is useful when you already know the frequency of the desired station.
- After selecting the desired band, press the TUNING buttons repeatedly until the right frequency has been reached.

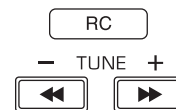

Auto presetting

- Auto presetting function automatically searches for FM stations and store them in the memory.
- While listening to FM radio broadcasts, press and hold down the OK button for more than 2 seconds.



- Then "AUTO MEM" flickers and this receiver starts auto presetting.
- To stop auto presetting, press this button again.
- Up to 30 FM stations can be stored.

■Notes:

- FM stations of weak strength cannot be memorized.
- To memorize weak stations, perform "Manual presetting" procedure with using "Manual tuning" operation.

Presetting radio stations

- You can store up to 30 preferred stations in the memory.

1. Tune in the desired station with auto or manual tuning.

2. Press the OK button.

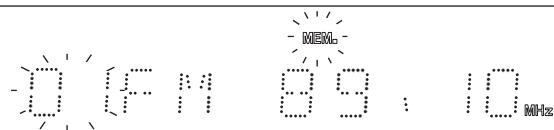

3. Select the desired preset number (1~30) and press the OK button.

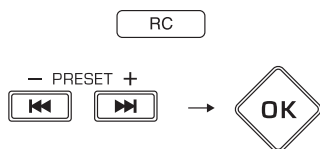

- When using the NUMERIC buttons on the remote control.

Example)

For "3" : →

For "15" : →

For "30" : →

- The station has now been stored in the memory.
- A stored frequency is erased from the memory by storing another frequency in its place.
- When entering a number other than 1~3 with the NUMERIC buttons, the station is stored automatically without pressing the OK button.

4. Repeat the above steps 1 to 3 to memorize other stations.

■ MEMORY BACKUP FUNCTION

The following items, set before the receiver is turned off, are memorized.

- INPUT SELECTOR settings
- Surround mode settings
- Preset stations, etc.

Tuning to preset stations

- After selecting the tuner as an input source, select the desired preset number.



- When using the NUMERIC buttons on the remote control.

Example)

For "3" :

For "15" : → (within 2 seconds)

For "30" : → (within 2 seconds)

RDS Tuner(Regional Option for some countries in Europe, etc.)

LISTENING TO RDS BROADCASTS(FM ONLY)

RDS(Radio Data System) is a method for sending information signals together with the transmitter signals. Your tuner is capable of translating these signals and putting the information on the display. These codes contain the following information. Program Service name(PS), A list of Program Types(PTY), Radio Text(RT).

Notes :

- In the other countries, RDS tuner function cannot be available.
- RDS is only possible in the FM band.
- RDS searches for the preset stations only. If no stations have been stored in the memory, or if the program type could not be found among the preset stations, "NO PTY" is displayed. Therefore, preset the radio stations before searching for RDS stations.

Searching for stations by program type

- You can search for stations by program type.

1. In the FM mode, press the SEARCH MODE button.

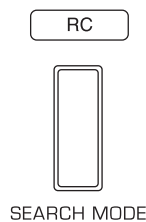

- "SEARCH" is displayed for several seconds.

2. While displaying "SEARCH", select the desired program type.

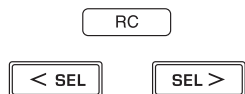

- Each time these buttons are pressed, one of different types of programs is selected.
(NEWS, AFFAIRS, INFO, SPORT, EDUCATE, DRAMA, CULTURE, SCIENCE, VARIED, POP M, ROCK M, EASY M, LIGHT M, CLASSICS, OTHER M, WEATHER, FINANCE, CHILDREN, SOCIAL, RELIGION, PHONE IN, TRAVEL, LEISURE, JAZZ, COUNTRY, NATION M, OLDIES, FOLK M, DOCUMENT)
- If "SEARCH" disappears, press the SEARCH MODE button again.

3. While displaying the selected program type, press the OK button.



- The tuner start searching through the preset stations for a match.
- When a station is found, the search stops and the stations plays for five seconds.
- If no stations is found, "NO PTY" is displayed.

4. If you want to keep listening to the station, press the OK button within the five seconds.

- If you don't press the OK button, searching resumes.

Displaying RDS information

- In the FM mode,

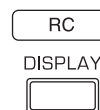

- Each time the DISPLAY button is pressed, the display mode changes as follows:

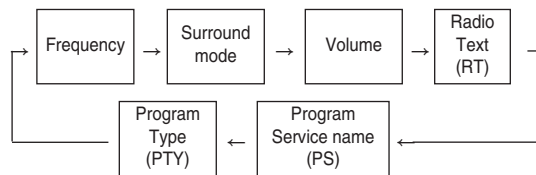

- * Radio Text (RT) - Messages sent by the radio station. For example, a talk radio station may provide a phone number as RT.
- * Program Service Name (PS) - The name of the radio station.
- * Program Type (PTY) - This indicates the kind of program currently being broadcast.
- If the signals are too weak or no RDS service is available, "NO TEXT", "NO NAME" or "NO PTY" will be displayed.

Troubleshooting Guide

If a fault occurs, run through the table below before taking your receiver for repair.

If the fault persists, attempt to solve it by switching the receiver off and on again. If this fails to resolve the situation, consult your dealer. Under no circumstances should you attempt to repair the unit yourself. This could void the warranty.

■ REMOTE CONTROL UNIT

PROBLEM	POSSIBLE CAUSE	REMEDY
No operation	<ul style="list-style-type: none"> Batteries are not loaded or exhausted. The remote sensor is obstructed. 	<ul style="list-style-type: none"> Replace the batteries. Remove the obstacle.

■ MAIN UNIT [AMPLIFIER SECTION]

PROBLEM	POSSIBLE CAUSE	REMEDY
No power	<ul style="list-style-type: none"> The AC input cord is disconnected. Poor connection at AC wall outlet or the outlet is inactive. 	<ul style="list-style-type: none"> Connect cord securely. Check the outlet using a lamp or another appliance.
No sound	<ul style="list-style-type: none"> The speaker cords are disconnected. The master volume is adjusted too low. The MUTE button on the remote control is pressed to ON. Incorrect selection of input source. Incorrect connections between the components. 	<ul style="list-style-type: none"> Check the speaker connections. Adjust the master volume. Press the MUTE button to cancel the muting effect. Select the desired input source correctly. Make connections correctly.
Noise or distorted sound	<ul style="list-style-type: none"> Poor connections. 	<ul style="list-style-type: none"> Check the connections and connect all cords securely.
No sound from the surround speakers	<ul style="list-style-type: none"> Surround mode is switched off(stereo mode). Master volume and surround level are too low. Monaural source is used. Surround speaker setting is "NO". 	<ul style="list-style-type: none"> Select a surround mode. Adjust master volume and surround level. Select a stereo or surround source. Select the desired surround speaker setting.
No sound from the center speaker	<ul style="list-style-type: none"> Stereo mode, etc is selected. Center speaker setting is "NO". Master volume and center level are too low. 	<ul style="list-style-type: none"> Select the desired surround mode. Select the desired center speaker setting. Adjust master volume and center level.
No sound from the surround back speakers	<ul style="list-style-type: none"> The input signal format or the current surround mode cannot support the 7.1(or 6.1) surround. Master volume and surround back level are too low. Surround back speaker setting is "NO". 	<ul style="list-style-type: none"> Under the proper situations, perform the 7.1(or 6.1) surround playback.(For details, refer to "ENJOYING SURROUND SOUND" on page 17.) Adjust master volume and surround back level. Select the desired surround back speaker setting.

[TUNER SECTION]

PROBLEM	POSSIBLE CAUSE	REMEDY
Station cannot be received	<ul style="list-style-type: none"> No antenna is connected. The desired station frequency is not tuned in. The antenna is in wrong position. 	<ul style="list-style-type: none"> Connect an antenna. Tune in the desired station frequency. Move the antenna and retry tuning.
Preset stations cannot be received	<ul style="list-style-type: none"> An incorrect station frequency has been memorized. The memorized stations are cleared. 	<ul style="list-style-type: none"> Memorize the correct station frequency. Memorize the stations again.
Poor FM reception	<ul style="list-style-type: none"> No antenna is connected. The antenna is not positioned for the best reception. 	<ul style="list-style-type: none"> Connect an antenna. Change the position of the antenna.

[BD PLAYER SECTION]

PROBLEM	POSSIBLE CAUSE	REMEDY
No playback	<ul style="list-style-type: none"> • The disc is loaded upside down. • The disc is not playable. • The disc is dirty. • The recorded disc is not correctly finalized. • The parental level is not set correctly. <ul style="list-style-type: none"> • The symbol about invalid operation is displayed. 	<ul style="list-style-type: none"> • Reload the disc with the printed side up. • Use a playable disc. • Clean the disc. • Load a disc that is correctly finalized. • Set the parental level setting correctly. (Refer to "SETTING THE PARENTAL CONTROL" on page 44.) • Adjust the setting correctly. (Refer to "SYMBOL ABOUT INVALID OPERATION" on page 25.)
Malfunction	<ul style="list-style-type: none"> • The disc is scratched, dirty badly or unplayable. 	<ul style="list-style-type: none"> • Press the POWER ON/STANDBY button to turn the power off, press this button again and then unload the disc.
No picture	<ul style="list-style-type: none"> • The video cords are disconnected. • The incorrect selection of input source on the TV. • The disc is not playable. 	<ul style="list-style-type: none"> • Connect the cords correctly. • Select the input source correctly. • Use a playable disc.
Noisy or distorted picture	<ul style="list-style-type: none"> • The unit is connected to a VCR directly and the copyguard function is activated. • The disc is dirty. • It is in rapid advance or reverse playback, or in frame advance playback. 	<ul style="list-style-type: none"> • Connect the unit so that the picture signal is transferred directly to the TV. • Clean the disc. • Sometimes small amount of picture distortion may appear. This is not malfunction.
Abnormal picture or no picture	<ul style="list-style-type: none"> • The resolution is not set correctly for video signals to be output from the COMPONENT and the HDMI OUTs. • The TV does not support HDCP. <ul style="list-style-type: none"> • The TV type of this unit is different from that of your TV or the disc. 	<ul style="list-style-type: none"> • Set the resolution correctly. (Refer to "SETTING THE DISPLAY" on page 42.) • This unit will not transfer the video signals via HDMI connector to TV that does not support HDCP. This is not malfunction. • Set the TV type correctly. (Refer to "SETTING THE DISPLAY" on page 42.)
Slight pause of picture	<ul style="list-style-type: none"> • The layer transition occurs during playback of DVD Videos, etc. recoded in dual-layer format. 	<ul style="list-style-type: none"> • Sometimes slight pause may occur. This is not malfunction.
Noisy or distorted sound	<ul style="list-style-type: none"> • The disc is dirty. 	<ul style="list-style-type: none"> • Clean the disc.
BD-LIVE contents cannot be loaded	<ul style="list-style-type: none"> • Poor connections between this unit and broadband router and/or modem. • The USB memory device is disconnected. • The BD-Live Internet Access is set to "Prohibit Access". • The BD disc does not support BD-LIVE. • The network settings are not set correctly. 	<ul style="list-style-type: none"> • Check the connections and connect all cords securely. • Connect the USB memory device to this unit. • Set it to "Always Allow Access" (Refer to "SETTING THE SYSTEM" on page 41.) • Load a disc that supports BD-LIVE. • Set the network settings correctly. (Refer to "SETTING THE NETWORK" on page 45.)

Specifications

[AMPLIFIER SECTION]

- Power output, stereo mode, 6 Ω , THD 0.5 %, 1 kHz | **2 \times 100 W**
- Total harmonic distortion at -3 dB, 6 Ω , 1 kHz | **0.5%**
- Input sensitivity/impedance
 - Line (SAT, AUX, TV) | **200 mV/47k Ω**
- Signal to noise ratio, IHF "A" weighted
 - Line (SAT, AUX, TV) | **95 dB**
- Frequency response
 - Line (SAT, AUX, TV), 20 Hz ~ 60 kHz | **+0, -3 dB**
- Bass/Treble control, 100 Hz/10 kHz | **\pm 10 dB**
- Surround mode, only channel driven
 - Front power output, 6 Ω , 1 kHz, THD 0.7 % | **100 W / 100W**
 - Center power output, 6 Ω , 1 kHz, THD 0.7 % | **100 W**
 - Surround power output, 6 Ω , 1 kHz, THD 0.7 % | **100 W / 100W**
 - Subwoofer power output, 6 Ω , 30 Hz, THD 0.7 % | **100 W**
- Output level
 - SURROUND BACK PREOUT, 2.2 k Ω | **300 mV**
 - SUBWOOFER PREOUT, 30 Hz | **2.3 V**

[VIDEO SECTION]

- Output level, 75 Ω
 - Video (regular, COMPOSITE) | **1.0 Vp-p**
 - Component video : Y / Pb / Pr | **1.0 / 0.7 / 0.7 Vp-p**
 - HDMI connector | **19 pin**

[DIGITAL AUDIO SECTION]

- Sampling frequency | **32, 44.1, 48, 96 kHz**
- Digital input level
 - Coaxial, 75 Ω | **0.5 Vp-p**
 - Optical, 660 nm | **-15 ~ -21 dBm**

[BD PLAYER SECTION]

- Pickup | **Semiconductor laser**
- Video format | **NTSC/PAL**
- Frequency response
 - BD (Linear PCM), Sampling frequency : 48 kHz | **20 Hz~22 kHz**
 - Sampling frequency : 96 kHz | **20 Hz~44 kHz**
 - Sampling frequency : 192 kHz | **20 Hz~88 kHz**
 - DVD (Linear PCM), Sampling frequency : 48 kHz | **20 Hz~22 kHz**
 - Sampling frequency : 96 kHz | **20 Hz~44 kHz**
 - CD, Sampling frequency : 44.1 kHz | **20 Hz~20 kHz**
- Signal to noise ratio, IHF "A" weighted | **100 dB**
- Dynamic range
 - BD / DVD / CD | **100 dB / 100 dB / 98 dB**
- Total harmonic distortion, 1 kHz | **0.003 %**
- Wow and flutter | **Unmeasurable (less than \pm 0.002 %)**

[FM TUNER SECTION]

- Tuning frequency range | **87.5~108 MHz**
- Usable sensitivity, THD 3%, S/N 30 dB | **9 dBf**
- Signal to noise ratio, 65 dBf, mono/stereo | **70 / 65 dB**
- Total harmonic distortion, 65 dBf, 1 kHz, mono/stereo | **0.8 / 1.0 %**
- Frequency response, 100 Hz~15 kHz | **±3 dB**

[GENERAL]

- BD Storage / Service | **USB 2.0 High Speed (480 Mbit/s)**
- LAN | **10 BASE-T / 100 BASE-TX**
- Power supply | **230V ~ 50 Hz**
- Power consumption | **110 W**
- Operating temperature | **+41°F ~ +95°F (+5°C ~ +35°C)**
- Dimensions (W× H× D, including protruding parts) | **435x105.5x387 mm (17-1/8x4-1/8x15-1/4 inches)**
- Weight (Net) | **6.6 kg (14.6 lbs)**

Note: Design and specifications are subject to change without notice for improvements.

Setup Code Table

TV

ENGLISH

ADMIRAL	050	134				
AKAI	093	049	123			
ALBA	068					
ALBIRAL	116					
ALCATEL	022					
AMSTRAD	158	021				
ANAM	155	156	157			
ARC EN CIEL	028	039	043	145	081	
ARISTONA	099	049	050	019	142	149
	078					
ARTHUR MARTIN	053	139	117	120	122	123
	125	128				
ASA	050	055	057	113	134	
ATLANTIC	099	111				
AUDIOSONIC	054					
AUSIND	053					
AUTOVOX	099	144	055	019	057	069
BAIRD	083					
BASICLINE	006					
BAUR	011					
BEKO	023	049				
BLAUPUNKT	094	100	102	111	114	
BENQ	159					
BRANDT	028	039	040	043	145	081
BRION VEGA	050					
BRUNS	048	050				
BSR	059	110	132			
BUSH	033	068	124	074		
CENTURY	098	101	050	079	136	
CGE	016	101	124	079	132	136
CIHAN	065					
CLARIVOX	048	116				
CONDOR	099	111				
CONTEC	087					
CONTINENTAL						
EDITION	028	039	040	043	145	081
CROSLEY	101	050	109			
CROWN	147					
CTC CLATRONIC	046					
DAEWOO	089					
DECCA	099	060	063	115	118	
DEGRAAF	036					
DIXI	049	090				
DRYNATRON	049					
DUAL	099	141				
DUAL-TEC	096	099	132			
DUMONT	046	050	057	073		
ELBE	016	116				
ELBIT	065					

ELCIT	046	097	103	050	109	127
	132					
ELMAN	046	132				
ELTA	090					
EMERSON	158	098	050			
ERRES	049	142				
EUROPHON	098	046	097	099	051	115
	132					
FERGUSON	146	040	041	150	057	061
	116	149				
FIDELITY	099	149				
FINLUX	034	046	053	055	057	109
	113	073	074	079		
FISHER	015	048	050	052	109	136
FORGESTONE	149					
FORMENTI	099	053	109	111	125	
FORTRESS	137					
FRABA	075					
FRONTECH	054					
FUJITSU	025					
FUNAI	054	059				
GBC	109	132				
GEC	099	060	109	115	134	088
GELOSO	103	109	132	134	090	
GOLDSTAR	092	003	017	099	049	075
	076	077	090	152		
GOODMANS	033	049	060	077		
GORENJE	066	136				
GREATZ	001	058	109	122	123	128
	129	130	134			
GRANADA	033	099	049	058	060	142
	115	125	134			
GRUNDIG	094	100	057	058	108	112
	114	082				
HANSEATIC	033	047	099	049	109	139
	111					
HANTAREX	097					
HEMMERMANN	127					
HIFIVOX	028	039	043	145	081	
HINARI	158	033	045	143	090	
HITACHI	014	033	034	036	099	145
	056	109	139	110	067	117
	132	134	084	091	081	088
HYPER	093	099				
IMPERIAL	016	101	124	079	132	133
INGELEN	001	058	109	122	128	129
	130	134				
SHERWOOD	000	001	002			

INNO HIT	093	098	097	099	143	077	NORDMENDE	028	032	039	043	145	131
	090							091	081				
INTERFUNK	047	049	050	145	058	109	OCEANIC	109	064	123			
	142	123	128	129	091		ONCEAS	099					
IRRADIO	093	143	053	077	090		OPTONICA	137					
ITT	001	140	058	105	109	122	ORION	158	059	118	068	127	090
	123	128	148	129	130	134	OSAKI	060					
	135	083	089				OSIO	077					
JVC	033	154					OSUME	087					
KTV	099						OTTO VERSAND	033	047	049	109	139	
KAISUI	006						P.T ACTTRON	065					
KARCHER	006						PAEL	099	053				
KENDO	098						PANASONIC	030	042	095	104	107	109
KENNEDY	144	019	109					121	126				
KORTING	050	059	111				PATHE CINEMA	099	111	116	132		
KRIESLER	099	049	050	019	142	149	PERDIO	060					
	078						PHILCO	016	030	101	050	109	124
LENOIR	099							079	132	136			
LOEWE OPTA	008	097	047	049	050	115	PHILIPS	009	010	013	018	024	099
	072							049	050	019	142	148	149
LOGIK	118	149						078	088				
LUMA	049	120	134				PHOENIX	099	053	109	111	125	
LUXOR	058	139	117	120	123	129	PHONOLA	099	049	050	019	142	149
	135	083						078					
MAGNADYNE	046	097	103	050	109	115	PIONEER	020	049	145	091		
	127	132					PRANDONI-						
MAGNAFON	046	097	099	051	053	115	PRINCE	098	097	053	115	134	
MARANTZ	049						PREMIER	124					
MATSUI	158	099	106	060	118	068	PRINCE	098	097	053	134		
	134	090					PROTECH	049	054				
McMICHAEL	088						PYE	099	049	050	019	142	148
MEMOREX	090							149	078				
METZ	094	050	114	133			QUASAR	046	097	051	053	077	
MINERVA	094	100	057	058	114		QUELLE	047	099	100	049	053	055
MISTRAL	149							057	058	111	112	113	114
MITSUBISHI	033	035	047	049	050	062		118	123	073	074	128	
	118	119	148	080	138		RADIOLA	099	049	050	019	142	149
MIVAR	097	099	115	077				078					
MULTITECH	046	099	115	136			RADIOMARELLI	046	097	103	050	109	062
MURPHY	134							127	132				
MAONIS	096	144	019	110	134		RANK	074					
NATIONAL	042	104	109				RBM	074					
NEC	033	085					REDIFFUSION	062	123	134			
NECKERMANN	099	050	139	120	136		REX	096	144	019	141	110	069
NEI	049							134					
NIKKAI	060						ROBOTRON	048	050				
NOBLEX	015						RTF	048	050				
NOBLIKO	098	046	099	053	057		SABA	028	031	032	037	039	040
NOGAMATIC	028	039	043	145	081			043	097	050	145	115	120
NOKIA	161	140	058	105	109	122		086	091	081			
	123	128	148	129	130	134	SAISHO	158	099	118	119	068	090
	135	083	089				SALORA	053	139	117	120	122	123
								125	128	135	083		

SAMBERS	046	097	051	053	115	077
SAMPO	121					
SAMSUNG	015	026	099	054	077	136
	090	151	153			
SANYO	161	162	005	033	044	048
	060	113	118	071	054	136
SBR	049	142	148	149	088	
SCHAUB LORENZ	161	058	109	122	123	128
	129	130	134			
SCHNEIDER	096	099	049	050	052	019
	141	109	142	125	149	078
	132					
SEG	046					
SEI	158	059				
SELECO	016	096	144	019	141	110
	069	134				
SHARP	033	087	137			
SIAREM	046	097	050	109	115	
SICATEL	116					
SIEMENS	005	094	036	100	111	114
	087					
SIERA	099	049	050	019	142	149
	078					
SILVER	054					
SINGER	016	046	050	109		
SINUDYNE	158	046	050	059	109	127
SONOKO	049	090				
SONY	146	007	027	033	038	118
STERN	096	144	019	110	069	134
TANDBERG	133					
TANDY	099	060	137			
TASHIKO	162	033				
TATUNG	099	060	063	065	115	118
TEC	096	099	132			
TELEAVIA	028	039	040	043	145	091
	081					
TELEFUNKEN	028	041	145	150	086	091
TELETECH	090					
TELEVIDEON	099	053	109	111	125	
TENSAI	049					
THOMSON	012	028	032	039	040	043
	145	091	081			
THORN- FERGUSON	014	040	041	054	150	057
	061	116	149	086		
TOCOM	029					
TOSHIBA	004	016	033	070	074	
TRANS						
CONTINENTS	098	097	053	134		
TRIUMPH	158					
UHER	052	111	125			
ULTRA VOX	098	046	099	050	109	120
UNIVERSUM	092	034	054	077		

UNIVOX	116					
VEGAVOX	079					
VOXSON	050	134				
WATSON	111					
WATT RADIO	046	099	051	109	116	127
WEGA	033					
WHITE						
WESTINGHOUSE	099	111				
YOKO	099					
ZANUSSI	096	144	019	110	069	134
ZOPPAS	096	144	019	110	134	

CBL

ABC	002	003	009	030		
	006	008				
Allegro	018	021				
Archer	018	026				
Bell&Howell	009					
Century	018					
Citizen	018	021				
Comtronics	014					
Contec	011					
Easten	001					
Emerson	026					
Everquest	010	014				
Focus	022					
Garrard	018					
Gemini	010					
General Instrument	033	276	006	034		
GoldStar	017	040				
Goodmind	026					
Hamlin	012	020	004	013		
Hitachi	006					
Jasco	010	018	021			
Jerrold	002	007	033	032	009	010
	006	034				
Movie Time	015					
NSC	015					
Oak	011					
Optimus	031					
Panasonic	016	031				
Philips	018					
Pioneer	017	025				
Popular Mechanics	022					
RCA	031					
Radio Shack	010	021	026	028		
Recoton	022					
Regal	012	020				
Regency	001					
Rembrandt	006					

SL Marx	014
Samsung	017 014
Scientific Atlanta	003 023 030 027
SHERWOOD	000
Signal	010 014
Signature	006
Sprucer	031
Starcom	002 010
Stargate	010 014 026
Starquest	010
TV86	015
Televue	014
Tocom	007 008
Tusa	010
Unika	018
Universal	018 019
Viewstar	015
Zenith	024
Zentek	022

SAT

ALBA	030
AMSTRAD	008 019 027
ARCON	021
ARISTONA	016
ASTRA	028
BLAUPUNKT	033
BUSH	016
CH.MASTER	030
CITY COM	005
DDC	030
DYNASAT	005
EHOSTAR	002 009 032 020
EMME ESSE	005
FAIT	005
FERGUSON	014 041 016 017 018
FINLUX	006 007 013
FRACARRO	005
FTE	022
GOLDSTAR	004 021
GRAETZ	026 037
GROTHUSEN	004
GRUNDIG	033 016 018 036
HINARI	030
HIRSCHMANN	003 006
HITACHI	013
INGELEN	026 037
ITT	034
ITT-NOKIA	032 018 026 037
JERROLD	038 014

KATHREIN	005 022 023
KOSMOS	004
KRIESLER	016
LENCO	004 021
LUXOR	026 037
MAGAI	022
MARANTZ	012
MASPRO	016
METZ	036
MINERVA	036
MULTISTAR	022
MURATO	004
NEC	040
NEIRU	021
NOKIA	026 037
NORSAT	015
PACE	001 042 016 017 018 044
PANASONIC	032
PHILIPS	003 011 012 029
PHONOLA	016
PROSAT	030
PYE	016
QUADRAL	030
QUELLE	036
RADIOLA	016
REDIFFUSION	015
SABA	035
SALORA	026
SAMSUNG	003 022
SAT PARTNER	004
SATPORTNER	021
SCHAUB LORENZ	026 037
SCHNEIDER	005 016
SHERWOOD	000
SIEMENS	033 036
SIERA	016
SILVA	004 021
SKY	039
STARCOM	038
STARSAT	022
TECHNISAT	003
TELEFUNKEN	025
TELESYSTEM	005
THORN- FERGUSON	010 014 041 016 017 018 043
TRIAD	004
UNIDEN	022
UNITED CABLE	038
VTECHNOLOGY	004
VORTEC	003 024 025
ZENDER	022

ENGLISH

License

- This product uses some software programs which are distributed under the GPL license. Accordingly, the following GPL software source codes that have been used in this product can be provided after asking at <http://www.sherwoodamerica.com>.

GNU GENERAL PUBLIC LICENSE
Version 2, June 1991

Copyright (C) 1989, 1991 Free Software Foundation, Inc.
51 Franklin Street, Fifth Floor, Boston, MA 02110-1301, USA

Everyone is permitted to copy and distribute verbatim copies of this license document, but changing it is not allowed.

Preamble

The licenses for most software are designed to take away your freedom to share and change it. By contrast, the GNU General Public License is intended to guarantee your freedom to share and change free software--to make sure the software is free for all its users. This General Public License applies to most of the Free Software Foundation's software and to any other program whose authors commit to using it. (Some other Free Software Foundation software is covered by the GNU Lesser General Public License instead.) You can apply it to your programs, too.

When we speak of free software, we are referring to freedom, not price. Our General Public Licenses are designed to make sure that you have the freedom to distribute copies of free software (and charge for this service if you wish), that you receive source code or can get it if you want it, that you can change the software or use pieces of it in new free programs; and that you know you can do these things.

To protect your rights, we need to make restrictions that forbid anyone to deny you these rights or to ask you to surrender the rights. These restrictions translate to certain responsibilities for you if you distribute copies of the software, or if you modify it.

For example, if you distribute copies of such a program, whether gratis or for a fee, you must give the recipients all the rights that you have. You must make sure that they, too, receive or can get the source code. And you must show them these terms so they know their rights.

We protect your rights with two steps: (1) copyright the software, and (2) offer you this license which gives you legal permission to copy, distribute and/or modify the software.

Also, for each author's protection and ours, we want to make certain that everyone understands that there is no warranty for this free software. If the software is modified by someone else and passed on, we want its recipients to know that what they have is not the original, so that any problems introduced by others will not reflect on the original authors' reputations.

Finally, any free program is threatened constantly by software patents. We wish to avoid the danger that redistributors of a free program will individually obtain patent licenses, in effect making the program proprietary. To prevent this, we have made it clear that any patent must be licensed for everyone's free use or not licensed at all.

The precise terms and conditions for copying, distribution and modification follow.

TERMS AND CONDITIONS FOR COPYING, DISTRIBUTION AND MODIFICATION

0. This License applies to any program or other work which contains a notice placed by the copyright holder saying it may be distributed under the terms of this General Public License. The "Program", below, refers to any such program or work, and a "work based on the Program" means either the Program or any derivative work under copyright law: that is to say, a work containing the Program or a portion of it, either verbatim or with modifications and/or translated into another language. (Hereinafter, translation is included without limitation in the term "modification".) Each licensee is addressed as "you".

Activities other than copying, distribution and modification are not covered by this License; they are outside its scope. The act of running the Program is not restricted, and the output from the Program is covered only if its contents constitute a work based on the Program (independent of having been made by running the Program). Whether that is true depends on what the Program does.

1. You may copy and distribute verbatim copies of the Program's source code as you receive it, in any medium, provided that you conspicuously and appropriately publish on each copy an appropriate copyright notice and disclaimer of warranty; keep intact all the notices that refer to this License and to the absence of any warranty; and give any other recipients of the Program a copy of this License along with the Program.

You may charge a fee for the physical act of transferring a copy, and you may at your option offer warranty protection in exchange for a fee.

2. You may modify your copy or copies of the Program or any portion of it, thus forming a work based on the Program, and copy and distribute such modifications or work under the terms of Section 1 above, provided that you also meet all of these conditions:
 - a) You must cause the modified files to carry prominent notices stating that you changed the files and the date of any change.
 - b) You must cause any work that you distribute or publish, that in whole or in part contains or is derived from the Program or any part thereof, to be licensed as a whole at no charge to all third parties under the terms of this License.
 - c) If the modified program normally reads commands interactively when run, you must cause it, when started running for such interactive use in the most ordinary way, to print or display an announcement including an appropriate copyright notice and a notice that there is no warranty (or else, saying that you provide a warranty) and that users may redistribute the program under these conditions, and telling the user how to view a copy of this License. (Exception: if the Program itself is interactive but does not normally print such an announcement, your work based on the Program is not required to print an announcement.)

These requirements apply to the modified work as a whole. If identifiable sections of that work are not derived from the Program, and can be reasonably considered independent and separate works in themselves, then this License, and its terms, do not apply to those sections when you distribute them as separate works. But when you distribute the same sections as part of a whole which is a work based on the Program, the distribution of the whole must be on the terms of this License, whose permissions for other licensees extend to the entire whole, and thus to each and every part regardless of who wrote it.

Thus, it is not the intent of this section to claim rights or contest your rights to work written entirely by you; rather, the intent is to exercise the right to control the distribution of derivative or collective works based on the Program.

In addition, mere aggregation of another work not based on the Program with the Program (or with a work based on the Program) on a volume of a storage or distribution medium does not bring the other work under the scope of this License.

3. You may copy and distribute the Program (or a work based on it, under Section 2) in object code or executable form under the terms of Sections 1 and 2 above provided that you also do one of the following:
 - a) Accompany it with the complete corresponding machine-readable source code, which must be distributed under the terms of Sections 1 and 2 above on a medium customarily used for software interchange; or,
 - b) Accompany it with a written offer, valid for at least three years, to give any third party, for a charge no more than your cost of physically performing source distribution, a complete machine-readable copy of the corresponding source code, to be distributed under the terms of Sections 1 and 2 above on a medium customarily used for software interchange; or,
 - c) Accompany it with the information you received as to the offer to distribute corresponding source code. (This alternative is allowed only for noncommercial distribution and only if you received the program in object code or executable form with such an offer, in accord with Subsection b above.)

The source code for a work means the preferred form of the work for making modifications to it. For an executable work, complete source code means all the source code for all modules it contains, plus any associated interface definition files, plus the scripts used to control compilation and installation of the executable. However, as a special exception, the source code distributed need not include anything that is normally distributed (in either source or binary form) with the major components (compiler, kernel, and so on) of the operating system on which the executable runs, unless that component itself accompanies the executable.

If distribution of executable or object code is made by offering access to copy from a designated place, then offering equivalent access to copy the source code from the same place counts as distribution of the source code, even though third parties are not compelled to copy the source along with the object code.

4. You may not copy, modify, sublicense, or distribute the Program except as expressly provided under this License. Any attempt otherwise to copy, modify, sublicense or distribute the Program is void, and will automatically terminate your rights under this License. However, parties who have received copies, or rights, from you under this License will not have their licenses terminated so long as such parties remain in full compliance.

5. You are not required to accept this License, since you have not signed it. However, nothing else grants you permission to modify or distribute the Program or its derivative works. These actions are prohibited by law if you do not accept this License. Therefore, by modifying or distributing the Program (or any work based on the Program), you indicate your acceptance of this License to do so, and all its terms and conditions for copying, distributing or modifying the Program or works based on it.
6. Each time you redistribute the Program (or any work based on the Program), the recipient automatically receives a license from the original licensor to copy, distribute or modify the Program subject to these terms and conditions. You may not impose any further restrictions on the recipients' exercise of the rights granted herein. You are not responsible for enforcing compliance by third parties to this License.
7. If, as a consequence of a court judgment or allegation of patent infringement or for any other reason (not limited to patent issues), conditions are imposed on you (whether by court order, agreement or otherwise) that contradict the conditions of this License, they do not excuse you from the conditions of this License. If you cannot distribute so as to satisfy simultaneously your obligations under this License and any other pertinent obligations, then as a consequence you may not distribute the Program at all. For example, if a patent license would not permit royalty-free redistribution of the Program by all those who receive copies directly or indirectly through you, then the only way you could satisfy both it and this License would be to refrain entirely from distribution of the Program.

If any portion of this section is held invalid or unenforceable under any particular circumstance, the balance of the section is intended to apply and the section as a whole is intended to apply in other circumstances.

It is not the purpose of this section to induce you to infringe any patents or other property right claims or to contest validity of any such claims; this section has the sole purpose of protecting the integrity of the free software distribution system, which is implemented by public license practices. Many people have made generous contributions to the wide range of software distributed through that system in reliance on consistent application of that system; it is up to the author/donor to decide if he or she is willing to distribute software through any other system and a licensee cannot impose that choice.

This section is intended to make thoroughly clear what is believed to be a consequence of the rest of this License.

8. If the distribution and/or use of the Program is restricted in certain countries either by patents or by copyrighted interfaces, the original copyright holder who places the Program under this License may add an explicit geographical distribution limitation excluding those countries, so that distribution is permitted only in or among countries not thus excluded. In such case, this License incorporates the limitation as if written in the body of this License.
9. The Free Software Foundation may publish revised and/or new versions of the General Public License from time to time. Such new versions will be similar in spirit to the present version, but may differ in detail to address new problems or concerns.

Each version is given a distinguishing version number. If the Program specifies a version number of this License which applies to it and "any later version", you have the option of following the terms and conditions either of that version or of any later version published by the Free Software Foundation. If the Program does not specify a version number of this License, you may choose any version ever published by the Free Software Foundation.

10. If you wish to incorporate parts of the Program into other free programs whose distribution conditions are different, write to the author to ask for permission. For software which is copyrighted by the Free Software Foundation, write to the Free Software Foundation; we sometimes make exceptions for this. Our decision will be guided by the two goals of preserving the free status of all derivatives of our free software and of promoting the sharing and reuse of software generally.

NO WARRANTY

11. BECAUSE THE PROGRAM IS LICENSED FREE OF CHARGE, THERE IS NO WARRANTY FOR THE PROGRAM, TO THE EXTENT PERMITTED BY APPLICABLE LAW. EXCEPT WHEN OTHERWISE STATED IN WRITING THE COPYRIGHT HOLDERS AND/OR OTHER PARTIES PROVIDE THE PROGRAM "AS IS" WITHOUT WARRANTY OF ANY KIND, EITHER EXPRESSED OR IMPLIED, INCLUDING, BUT NOT LIMITED TO, THE IMPLIED WARRANTIES OF MERCHANTABILITY AND FITNESS FOR A PARTICULAR PURPOSE. THE ENTIRE RISK AS TO THE QUALITY AND PERFORMANCE OF THE PROGRAM IS WITH YOU. SHOULD THE PROGRAM PROVE DEFECTIVE, YOU ASSUME THE COST OF ALL NECESSARY SERVICING, REPAIR OR CORRECTION.
12. IN NO EVENT UNLESS REQUIRED BY APPLICABLE LAW OR AGREED TO IN WRITING WILL ANY COPYRIGHT HOLDER, OR ANY OTHER PARTY WHO MAY MODIFY AND/OR REDISTRIBUTE THE PROGRAM AS PERMITTED ABOVE, BE LIABLE TO YOU FOR DAMAGES, INCLUDING ANY GENERAL, SPECIAL, INCIDENTAL OR CONSEQUENTIAL DAMAGES ARISING OUT OF THE USE OR INABILITY TO USE THE PROGRAM (INCLUDING BUT

NOT LIMITED TO LOSS OF DATA OR DATA BEING RENDERED INACCURATE OR LOSSES SUSTAINED BY YOU OR THIRD PARTIES OR A FAILURE OF THE PROGRAM TO OPERATE WITH ANY OTHER PROGRAMS), EVEN IF SUCH HOLDER OR OTHER PARTY HAS BEEN ADVISED OF THE POSSIBILITY OF SUCH DAMAGES.

END OF TERMS AND CONDITIONS

How to Apply These Terms to Your New Programs

If you develop a new program, and you want it to be of the greatest possible use to the public, the best way to achieve this is to make it free software which everyone can redistribute and change under these terms.

To do so, attach the following notices to the program. It is safest to attach them to the start of each source file to most effectively convey the exclusion of warranty; and each file should have at least the "copyright" line and a pointer to where the full notice is found.

One line to give the program's name and a brief idea of what it does.

Copyright (C) <year><name of author>

This program is free software; you can redistribute it and/or modify it under the terms of the GNU General Public License as published by the Free Software Foundation; either version 2 of the License, or (at your option) any later version.

This program is distributed in the hope that it will be useful, but WITHOUT ANY WARRANTY; without even the implied warranty of MERCHANTABILITY or FITNESS FOR A PARTICULAR PURPOSE. See the GNU General Public License for more details.

You should have received a copy of the GNU General Public License along with this program; if not, write to the Free Software Foundation, Inc., 59 Temple Place, Suite 330, Boston, MA 02111-1307 USA

Also add information on how to contact you by electronic and paper mail.

If the program is interactive, make it output a short notice like this when it starts in an interactive mode:

Gnomovision version 69, Copyright (C) year name of author Gnomovision comes with ABSOLUTELY NO WARRANTY; for details type 'show w'. This is free software, and you are welcome to redistribute it under certain conditions; type 'show c' for details.

The hypothetical commands 'show w' and 'show c' should show the appropriate parts of the General Public License. Of course, the commands you use may be called something other than 'show w' and 'show c'; they could even be mouse-clicks or menu items--whatever suits your program.

You should also get your employer (if you work as a programmer) or your school, if any, to sign a "copyright disclaimer" for the program, if necessary. Here is a sample; alter the names:

Yoyodyne, Inc., hereby disclaims all copyright interest in the program 'Gnomovision' (which makes passes at compilers) written by James Hacker.
signature of Ty Coon, 1 April 1989
Ty Coon, President of Vice

This General Public License does not permit incorporating your program into proprietary programs. If your program is subroutine library, you may consider it more useful to permit linking proprietary applications with the library. If this is what you want to do, use the GNU Library General Public License instead of this License.

VR-654BD

BLU-RAY RECEIVER



5707-00000-281-1S

Free Manuals Download Website

<http://myh66.com>

<http://usermanuals.us>

<http://www.somanuals.com>

<http://www.4manuals.cc>

<http://www.manual-lib.com>

<http://www.404manual.com>

<http://www.luxmanual.com>

<http://aubethermostatmanual.com>

Golf course search by state

<http://golfingnear.com>

Email search by domain

<http://emailbydomain.com>

Auto manuals search

<http://auto.somanuals.com>

TV manuals search

<http://tv.somanuals.com>