

# OPERATING INSTRUCTIONS

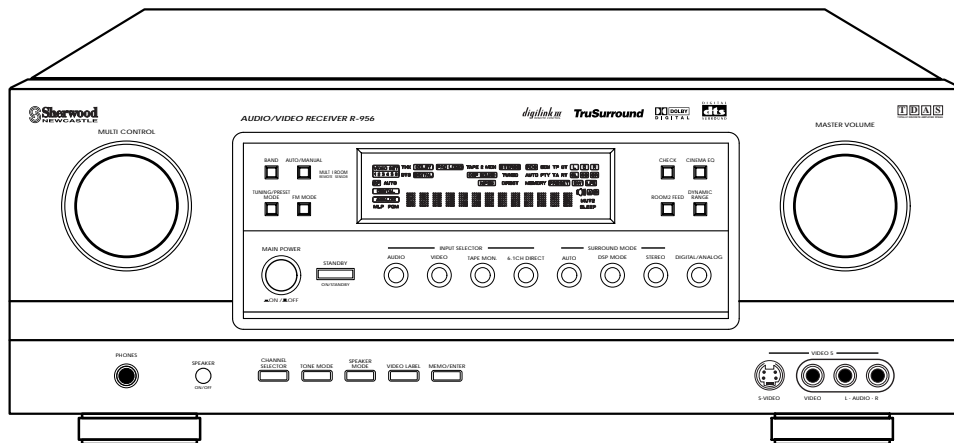

## R-956 AUDIO/VIDEO RECEIVER

# Introduction



## UNPACKING AND

ENGLISH

### Congratulations on Your Purchase!

Your new high fidelity receiver is designed to deliver maximum enjoyment and years of trouble free service. Please take a few moments to read this manual thoroughly. It will explain the features and operation of your unit and help ensure a trouble free installation. Please unpack your unit carefully. We recommend that you save the carton and packing material. They will be helpful if you ever need to move your unit and may be required if you ever need to return it for service. Your unit is designed to be placed in a horizontal position and it is important to allow at least two inches of space behind your unit for adequate ventilation and cabling convenience.

To avoid damage, never place the unit near radiators, in front of heating vents, in direct sunlight, or in excessively humid or dusty locations. Connect your complementary components as illustrated in the following section.

	<b>CAUTION</b> RISK OF ELECTRIC SHOCK DO NOT OPEN	
<b>CAUTION : TO REDUCE THE RISK OF ELECTRIC SHOCK, DO NOT REMOVE COVER (OR BACK). NO USER-SERVICEABLE PARTS INSIDE. REFER SERVICING TO QUALIFIED SERVICE PERSONNEL.</b>		



This symbol is intended to alert the user to the presence of uninsulated "dangerous voltage" within the product's enclosure that may be of sufficient magnitude to constitute a risk of electric shock to persons.



This symbol is intended to alert the user to the presence of important operating and maintenance (servicing) instructions in the literature accompanying the appliance.

### WARNING

To reduce the risk of fire or electric shock, do not expose this appliance to rain or moisture.

**Caution : Do not block ventilation openings or stack other equipment on the top.**

### FOR U.S.A.

■**Note to CATV System Installer:** This reminder is provided to call the CATV system installer's attention to Article 820-40 of the NEC that provides guidelines for proper grounding and, in particular, specifies that the cable ground shall be connected to the grounding system of the building, as close to the point of cable entry as practical.

### ■FCC INFORMATION

This equipment has been tested and found to comply with the limits for a Class B digital device, pursuant to Part 15 of the FCC Rules. These limits are designed to provide reasonable protection against harmful interference in a residential installation. This equipment generates, uses and can radiate radio frequency energy and, if not installed and used in accordance with the instructions, may cause harmful interference to radio communications. However, there is no guarantee that interference will not occur in a particular installation. If this equipment does cause harmful interference to radio or television reception, which can be determined by turning the equipment off and on, the user is encouraged to try to correct the interference by one or more of the following measures:

- Reorient or relocate the receiving antenna.
- Increase the separation between the equipment and receiver.
- Connect the equipment into an outlet on a circuit different from that to which the receiver is connected.
- Consult the dealer or an experienced radio/TV technician for help.

**CAUTION :** Any changes or modifications in construction of this device which are not expressly approved by the party responsible for compliance could void the user's authority to operate the equipment.

### Caution regarding placement (Except for U.S.A. and Canada)

To maintain proper ventilation, be sure to leave a space around the unit (from the largest outer dimensions including projections) equal to, or greater than, shown below.

Left and right panels: 5 cm  
Rear panel: 10 cm  
Top panel: 20 cm

**READ THIS BEFORE OPERATING**

**FOR U.S.A. AND CANADA ..... 120 V**

**FOR YOUR SAFETY**

Units shipped to the U.S.A. and Canada are designed for operation on 120 Volts AC only.

Observe all safety precautions for use of a polarized AC plug. However, some products may be supplied with a non polarized plug.

**CAUTION:** To prevent electric shock, match wide blade of plug to wide slot, insert fully.

**FOR EUROPE AND AUSTRALIA .....230 V/240 V**

**FOR YOUR SAFETY**

Units shipped to Australia are designed for operation on 240 V AC only.

To ensure safe operation, the three-pin plug supplied must be inserted only into a standard three-pin power point which is effectively earthed through the normal household wiring. Extension cords used with the equipment must be three-core and be correctly wired to provide connection to earth.

Improper extension cords are a major cause of fatalities. The fact that the equipment operates satisfactorily does not imply that the power point is earthed and that the installation is completely safe. For your safety, if in any doubt about the effective earthing of the power point, consult a qualified electrician.

**PAN-EUROPEAN UNIFIED VOLTAGE**

All units are suitable for use on supplies 230-240 V AC.

**FOR OTHER COUNTRIES ..... 115 V/230 V**

**FOR YOUR SAFETY**

Units shipped to countries other than the above countries are equipped with an AC voltage selector switch on the rear panel. Refer to the following paragraph for the proper setting of this switch.

**AC VOLTAGE SELECTION**

This unit operates on 115/230 V AC. The AC voltage selector switch on the rear panel is set to the voltage that prevails in the area to which the unit is shipped. Before connecting the power cord to your AC outlet, make sure that the setting position of this switch matches your line voltage. If not, it must be set to your voltage in accordance with the following direction.

AC voltage selector switch

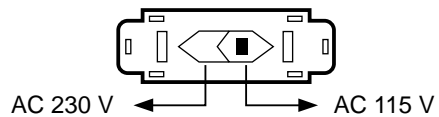

Move switch lever to match your line voltage with a

## CONTENTS

### Introduction

- UNPACKING AND INSTALLATION ..... 2
- READ THIS BEFORE OPERATING YOUR UNIT ..... 3

**System Connections** ..... 5

**Front Panel Controls** ..... 9

### Universal Remote Control

- DIGI LINK SYSTEM REMOTE CONTROLS ..... 10
- OPERATING COMPONENTS WITH REMOTE CONTROL ..... 12
- REMOTE CONTROL OPERATION RANGE ..... 12
- LOADING BATTERIES ..... 12
- ENTERING A SETUP CODE ..... 13

### Operations

- LISTENING TO A PROGRAM SOURCE ..... 14
- SURROUND SOUND ..... 17
- ENJOYING SURROUND SOUND ..... 19
- LISTENING TO RADIO BROADCASTS ..... 23
- RECORDING ..... 26
- DIGITAL AUDIO RECORDING WITH MD RECORDER ..... 27
- MULTI SOURCE PLAYBACK ..... 28
- OTHER FUNCTIONS ..... 29

### Using the OSD

- CURRENT STATUS DISPLAY ..... 31
- MENU SCREEN ..... 31

**Troubleshooting Guide** ..... 33

**Specifications** ..... 34

# System Connections

- When making system connections, please be certain the AC cord is not plugged into an AC outlet.
- When making connections between components, please be sure to connect the white RCA plugs to the L (left) and the red RCA plugs to the R (right) jacks respectively.
- Change the position of the FM indoor antenna until you get the best possible reception of your favorite FM stations.
- A 75 Ohm outdoor FM antenna may be used to further improve the reception. Disconnect the indoor antenna before connecting the outdoor antenna.
- Place the AM loop antenna as far as possible from the receiver, TV set, speaker cords and the AC input cord and set it to a direction for the best reception.
- If the reception is poor with the AM loop antenna, an AM outdoor antenna can be used in place of the AM loop antenna.
- Make all connections firmly and correctly. Failure to do so can cause loss of sound, noise or damage to the receiver.
- If the electricity fails or the AC cord is left unplugged for about two weeks, all operating parameters in the unit's memory will be lost. Should this happen, you must enter them again.

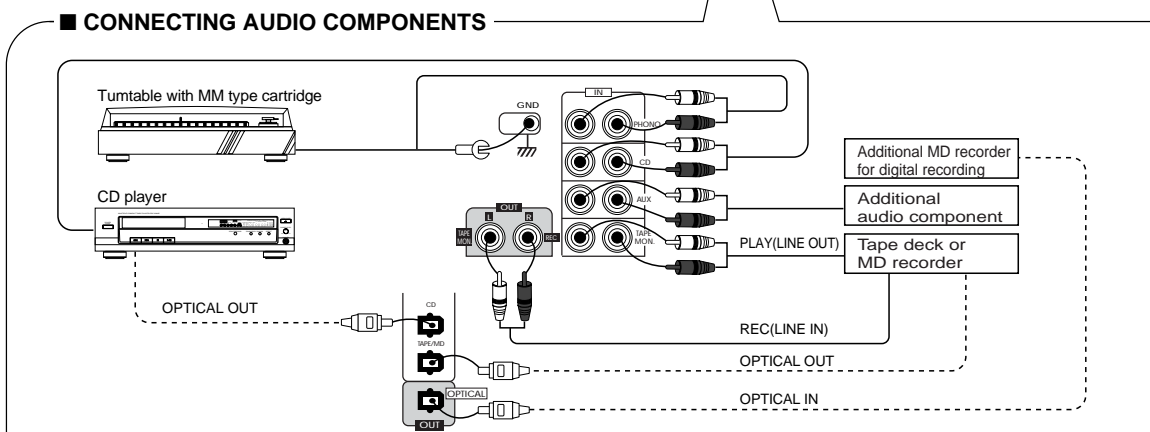
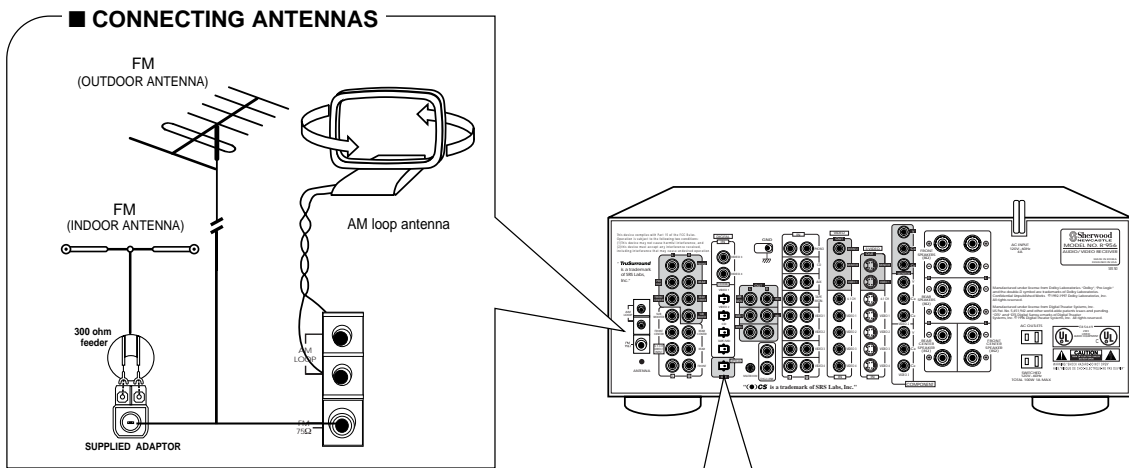

- The AUX jacks may be connected to an additional audio component such as a CD player, a tape deck, etc.□
  - Connect the TAPE MONITOR IN/OUT jacks to the PLAY(LINE OUT)/REC(LINE IN) jacks of a tape deck or MD recorder.□
  - The TAPE MONITOR IN/OUT jacks may also be connected to the LINE OUT/IN jacks of an optional graphic equalizer.□
  - If a digital recorder or other component with OPTICAL DIGITAL IN/OUT jacks is connected to the corresponding jacks of this unit, you can playback and/or record the high quality sound of CD's, etc. without analog conversion or degradation.□
- Notes:□
- The phono input of your receiver is not suitable for the direct connection of a turntable with a Moving Coil (MC) cartridge. If you have a MC cartridge, use a separate head amplifier of step-up transformer between the turntable and the receiver.□
  - Not all of the commercially available Fiber Optic cables are suitable for use with this receiver. If you have a question as to the suitability of any cable, please check with your dealer or a qualified service organization.□
  - Remove the protective cap before making any OPTICAL connections. Re-insert the protective cap when not using the OPTICAL jacks.

■ CONNECTING VIDEO COMPONENTS

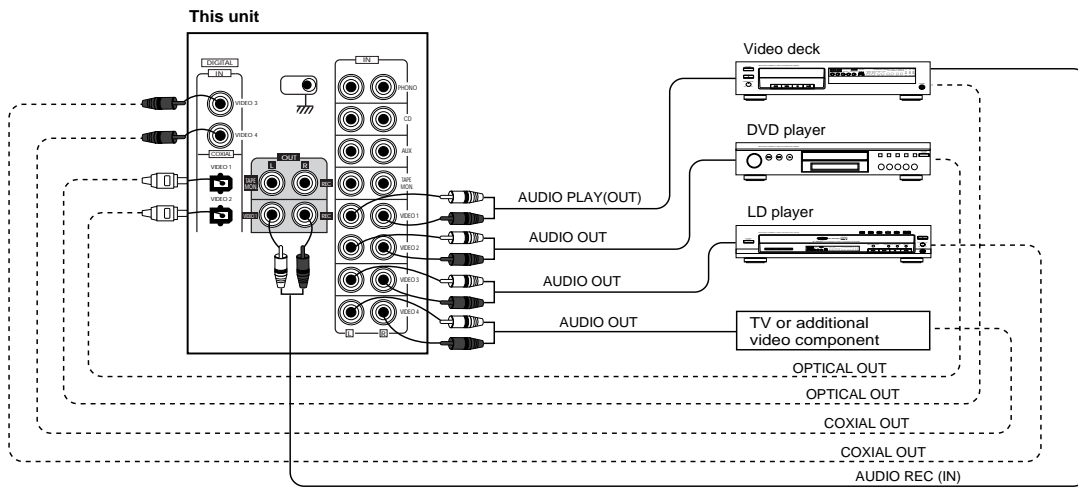

- This receiver has two kinds of digital jacks (OPTICAL, COAXIAL), three kinds of video jacks (COMPONENT, S-VIDEO, and COMPOSITE) as well as analog audio jacks for making connections with your video equipment. Depending on the capabilities of your video components, hook them up to the corresponding input/output jacks for VIDEO 1 to 4 respectively. □
- Notes: □
- When making COAXIAL DIGITAL connections use 75 Ohm Cable. Do not use standard audio patch cords. □
- Not all of the commercially available Fiber Optic cables are suitable for use with this receiver. If you have a question as to the suitability of any cable, please check with your dealer or a qualified service organization. □
- Remove the protective cap before making any OPTICAL connections. Re-insert the protective cap when not using the OPTICAL Jacks.

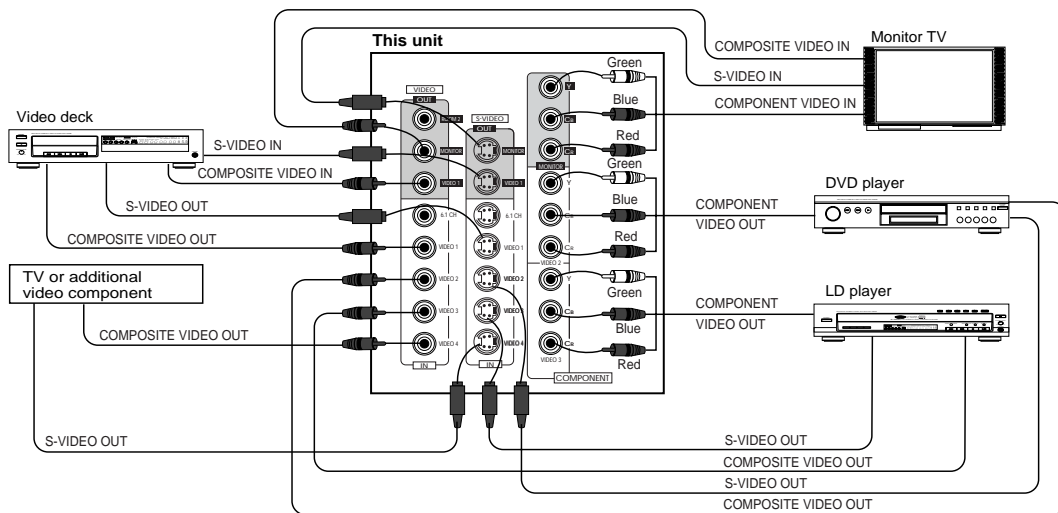

- This unit incorporates COMPONENT as well as S and composite(normal) VIDEO jacks. □
- For your reference, the excellence in picture quality is as follows: "COMPONENT" > "S" > "COMPOSITE". □
- When making COMPONENT VIDEO connections, connect "Y" to "Y", "Cb" to "Cb" (or "B-Y", "Pb") and "Cr" to "Cr" (or "R-Y", "Pr"). □
- Signals inputted into the COMPONENT VIDEO IN jacks will be outputted in only the MONITOR COMPONENT VIDEO OUT jacks. □
- A signal inputted into the composite(normal) VIDEO IN jack will be outputted in the composite(normal) VIDEO OUT jacks. □  
However, in case of S-VIDEO signal, a signal inputted into the S-VIDEO IN jack will be outputted in the S-VIDEO OUT jacks and the MONITOR composite(normal) VIDEO OUT jack besides. □
- Notes: □
- The on-screen display function and recording the component video signals are not available when using the COMPONENT VIDEO connections. □
- When Sherwood DVD player such as V-756, etc. is connected to the DIGI LINK jack for system control, you should connect the DVD player to the "VIDEO 2" jacks of this unit. □  
Because, if the PLAY button, etc. is pressed on the DVD player, the VIDEO 2 is automatically selected as an input source on this unit and the playback, etc. starts.

■ PRE OUT connections

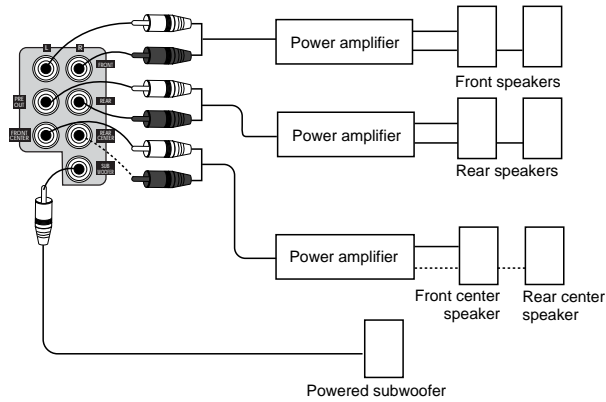

- Use these jacks when adding additional amplifiers. □
- Connect the PRE OUT jacks to the powered speakers or the power amplifiers connected to speakers respectively. □
- To emphasize the deep bass sounds, connect a powered subwoofer. □
- Only in case of enjoying 6.1 channels of digital audio, make the rear center connections between the audio equipment.

■ CONNECTING SPEAKERS

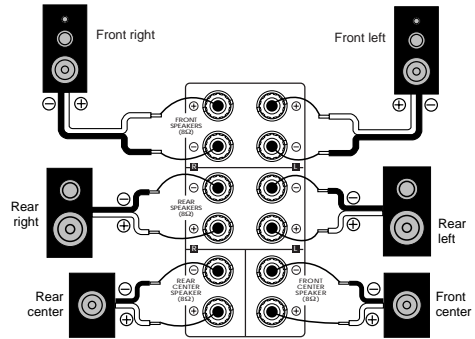

- The speaker terminals are designed to accept either bare wire or banana plugs. □
- If using bare wire, take care to not allow the + and - wires to touch or short. □
- Connect the speaker wires firmly and correctly according to the channel and position. Observe the proper polarity (+ and -). □
- To reproduce the center rear signal in 6.1 channel material, connect a rear center speaker. Otherwise the center rear speaker is not necessary. □
- This receiver is designed for use with speakers rated at 8 ohms impedance or above.

■ CONNECTING 6.1 CH DIRECT INPUTS

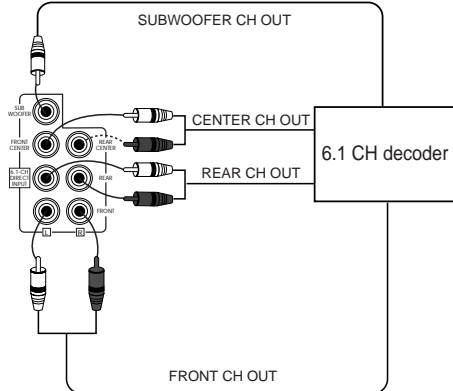

- Use these jacks to connect the corresponding analog outputs of an external 6.1 (or 5.1) channel decoder or to a DVD player with 6.1 (or 5.1) channel outputs. □
- In the case of a 5.1 channel decoder or DVD player, do not make a connection to the rear center input. (For more details, please see the operator's manual of the component to be connected.)

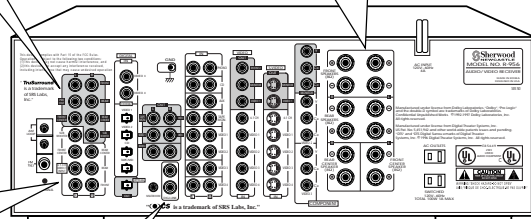

■ CONNECTING SYSTEM CONTROL

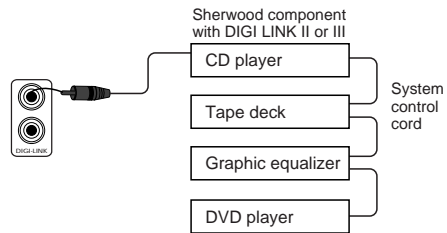

- Connect this jack to the DIGI LINK jack of the external Sherwood component that uses the DIGI LINK II or III remote control system.

■ ROOM 2 connections

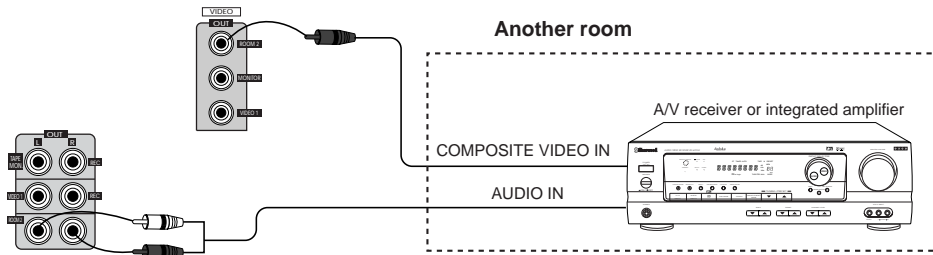

- If another A/V receiver or integrated amplifier, etc. is connected to these jacks, you can play a different program source in another room as well as one source in the main room at the same time. (For details, refer to "MULTI SOURCE PLAYBACK" on page 28). □
- When the multiroom adaptor is connected, the ROOM 2 functions is more convenient. □  
Note: □
- Use high quality connection cords in such a way that there is no humming or noise.

■ AC INPUT CORD

Plug this cord into a wall AC outlet.

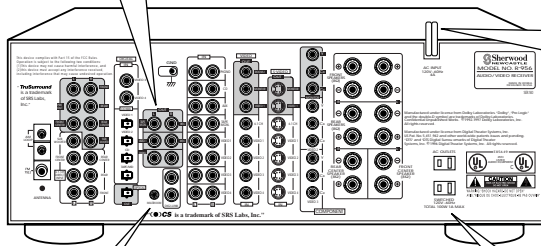

■ SWITCHED AC OUTLETS

- These outlets are switched on (power-on mode) and off (standby mode) according to power control as follows (Maximum total capacity is 1A, 100W): □  
□ Standby mode – switched AC outlet off □  
□ Power-on mode – switched AC outlet on □

■ CONNECTING MULTIROOM ADAPTOR

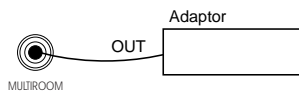

- To control this component from a remote location, connect this jack to the output of the multi-room adaptor. □  
For information on the multi-room adaptor, contact the Xantech corporation at 1-800-843-5465.



# Front Panel Controls

ENGLISH

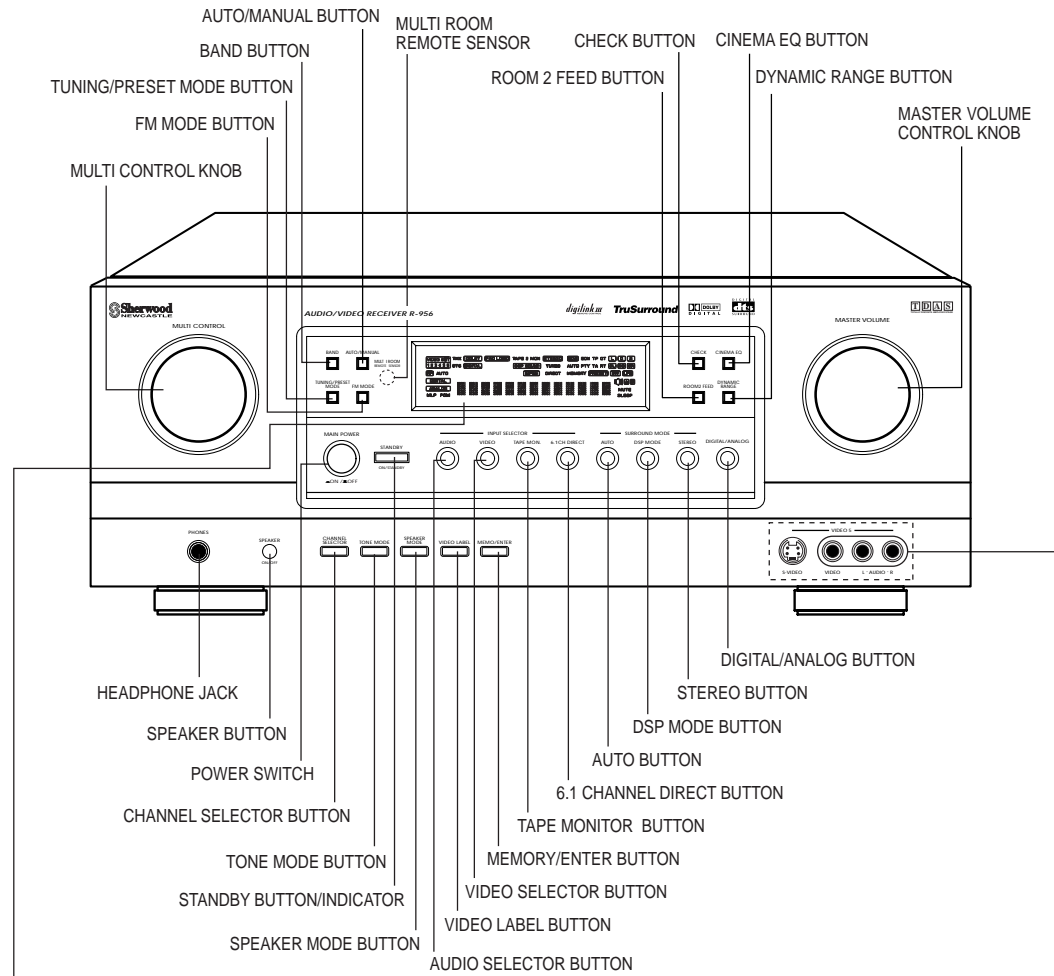

## ■ FLUORESCENT DISPLAY

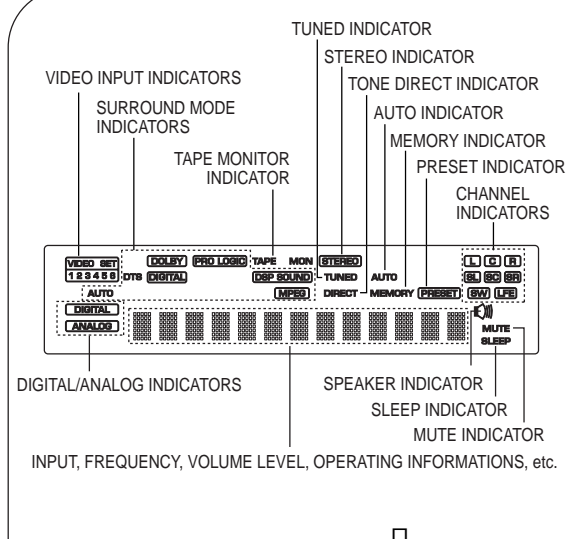

## ■ VIDEO 5 INPUT JACKS

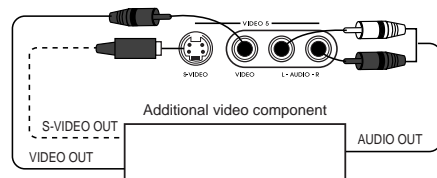

- The front VIDEO 5 input jacks may be also connected to an additional video component such as a camcorder, a video deck or a video game player, etc. □  
Use the S-VIDEO jack to make connection to video component with the S-VIDEO OUT jack. □
- A signal inputted into the composite(normal) VIDEO jack will be outputted in the composite(normal) VIDEO OUT jacks. □  
However, in case of S-VIDEO signal, a signal inputted into the S-VIDEO jack will be outputted in the S-VIDEO OUT jacks and the MONITOR composite(normal) VIDEO OUT jack besides.

## Universal Remote Control

Note: For additional Universal Remote Control programming instructions and manufacturer's codes, please refer to the operating manual enclosed with this Universal Remote Control.

This remote control has 3 operating modes as follows;

- OSD (On-Screen Display) Mode: Allows you to see information about basic operation of this unit on your TV or monitor and to operate this unit by moving an arrow(cursor) that appears on the TV screen.
- Sherwood Mode: Allows you to operate this unit and other Sherwood components like cassette decks, CD players, etc. via the remote control. (To operate other Sherwood components, please make the Digi Link connections between the components.)
- Non-Sherwood Mode: Allows you to operate other brands of audio and video components that are remote compatible.

Notes:



- The setup code for each component must be entered before the remote will operate the component.
- For setup codes (manufacturer's codes), please refer to the "MANUFACTURER'S CODES" in the operator's manual that came with the remote control.
- The buttons may have different functions depending upon the chosen component and the operating mode.
- Please be sure to set the remote control to the correct component mode before trying to operate any component.

### DIGI LINK SYSTEM REMOTE

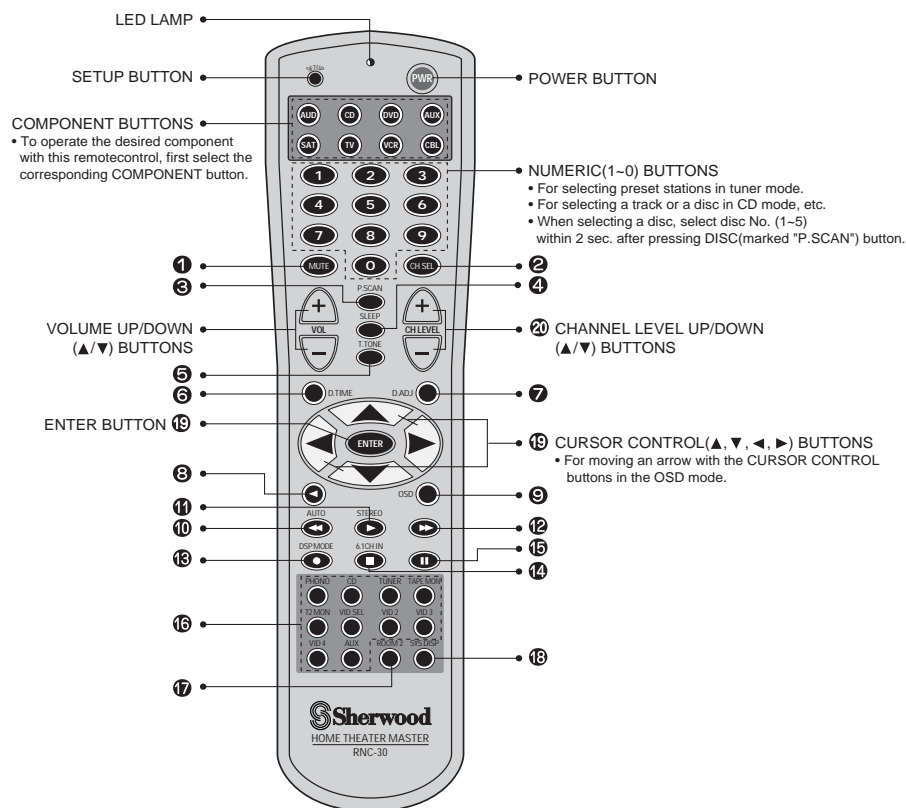
- This section explains the basic functions for the Sherwood and the OSD modes. For the non-Sherwood mode, please refer to the operating manual that came with the remote control.
- All Sherwood components bearing the DIGI LINK (II or III) logo can be used with this remote control.
- To control associated Sherwood Digi Link components, you must first make the DIGI LINK connections between the components.
- With the Sherwood Digi Link III system, pressing a transport control button such as PLAY, on a Sherwood CD player or tape deck will automatically engage that input on the receiver and then PLAY will start.
- The numbered buttons on the remote control have different functions in different modes. For details, please refer to the "FUNCTION TABLE for the NUMBERED BUTTONS" on the following page.
- Each time a button on the remote control is pressed, the buttons will illuminate for approximately 5 seconds.



## ■ FUNCTION TABLE of the NUMBERED BUTTONS.

Button symbol	Component buttons to control	 (for receiver)	 (for CD player)	 (for tape deck)	 (for DVD player)		 (for MD recorder)	
					V-756, etc. ("0633")	VD-4106, etc. ("0591")		
1		MUTE	—	—	CLEAR	—	+10	
2		CHANNEL SELECTOR	—	—	SEARCH	—	+100	
3		PRESET SCAN	DISC	—	OPEN/CLOSE	RETURN	EJECT	
4		SLEEP	—	—	DISPLAY	—	AUTO SPACE	
5		TEST TONE	—	—	SET UP	REPEAT A<->B	DISPLAY	
6		DELAY TIME	REPEAT A<->B	DECK SELECTOR A	TITLE	SETUP	REPEAT	
7		DELAY ADJUST	INTRO SCAN	DECK SELECTOR B	MENU	CLEAR	RANDOM	
8		—	—	REVERSE PLAY	REVERSE SKIP	DISPLAY	REVERSE SKIP	
9		ON-SCREEN DISPLAY	—	—	FORWARD SKIP	MENU	FORWARD SKIP	
10		AUTO	REVERSE SKIP	REWIND	REVERSE SEARCH	REVERSE SCAN	REVERSE SEARCH	
11		STEREO	PLAY	FORWARD PLAY	PLAY	PLAY	PLAY	
12		—	FORWARD SKIP	FAST FORWARD	FORWARD SEARCH	FORWARD SCAN	FORWARD SEARCH	
13		DSP MODE	—	RECORD	RETURN	—	RECORD	
14		6.1 CH DIRECT	STOP	STOP	STOP	STOP	STOP	
15		—	PAUSE	PAUSE	PAUSE	PAUSE	PAUSE	
16		I N P U T  S E L E C T O R	CD	—	—	AUDIO	—	EDIT CANCEL
			TUNER	—	—	ANGLE	ANGLE	DELETE/CLEAR
			TAPE MONITOR	—	—	ZOOM	—	CHARACTER/PROGRAM
			VIDEO SELECTOR	—	—	REPEAT A<->B	—	RECORD INPUT
			—	—	—	RANDOM	—	AUTO/MANUAL
			—	—	—	INTRO SCAN	—	SPACE/CHECK
			—	—	—	MARKER	—	TITLE INPUT
			AUX	—	—	SUBTITLE	—	TITLE SEARCH
			PHONO	—	—	SUBTITLE ON/OFF	SUBTITLE	EDIT
		—	—	—	REPEAT MODE	—	RECORD MODE	
17		ROOM 2 FEED	—	—	PROGRAM	—	SET	
18		SYSTEM DISPLAY	—	—	TIME	—	ENTER	
19		CURSOR UP(▲)	—	—	—	(PAUSE)	—	
		CURSOR DOWN(▼)	—	—	—	SLOW FORWARD	—	
		CURSOR RIGHT(▶)	—	—	—	(FORWARD SCAN)	—	
		CURSOR LEFT(◀)	—	—	—	(REVERSE SCAN)	—	
		ENTER	—	—	—	ENTER	—	
20		CH LEVEL UP(▲)	—	—	—	FORWARD SKIP	—	
		CH LEVEL DOWN(▼)	—	—	—	REVERSE SKIP	—	

### Notes:

- Some functions for CD player, tape deck, etc. may not be available.
- For details about functions, refer to the operating instructions of each component.

## OPERATING COMPONENTS WITH

**1** Enter the setup code for each component you wish to control. For details, refer to "ENTERING A SETUP CODE" (Page 13).

**2** Turn on the component you want to operate.

**3** Press the COMPONENT button on the remote control corresponding to the component you wish to operate.

**4** Aim the remote control at the REMOTE SENSOR of the component you wish to control and press the button corresponding to the operation you want.

- When operating a Sherwood CD player or tape deck using this system remote control, aim the remote control at the REMOTE SENSOR of this receiver.
- However, to operate a Sherwood DVD player or MD recorder, aim at the REMOTE SENSOR of the corresponding component.

## REMOTE CONTROL

- The operating range of the remote control is about 23 feet (7 Meters) and it will operate at angles of up to 30 degrees. Aim the remote at the remote sensor.

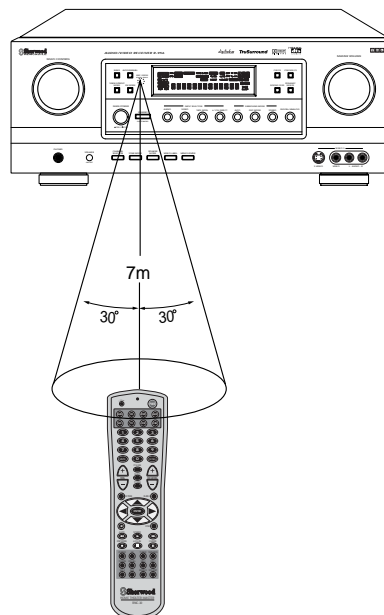

## LOADING BATTERIES

- Replace the batteries when the LED lamp flickers twice when any button is pressed.
- Replacing the batteries will restore proper operation and the memorized contents will be retained.

**1** Remove the cover.

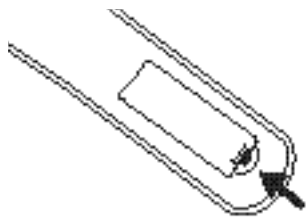

**2** Load 2 "AA" batteries (1.5 V) matching the polarity.

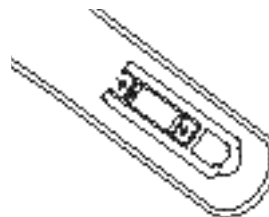

## ENTERING A SETUP CODE

- This remote control can control up to eight different components.
- Before operating audio and video components using the remote control supplied with this unit, the setup code for each component must be entered.
- For system remote control operation, because "0001" is stored previously in the memory of the component button "AUD" as its factory setup code for this receiver, "0004" in the memory of "AUX" for Sherwood tape deck, "1068" in the memory of "CD" for Sherwood CD player and "0633" in the memory of "DVD" for Sherwood DVD player such as V-756, etc., entering its code for each Sherwood component is not necessary except in case that its code does not work. However, for Sherwood MD recorder such as MD-7900R, etc., "0005" should be stored in the memory of "AUX" button and for some Sherwood DVD player such as VD-4106, etc., "0591" as a setup code for DVD player should be stored in the memory of "DVD" button.

Note: These codes for Sherwood components, including this receiver, are not listed in "MANUFACTURER'S CODES" in the operating manual of this remote control.

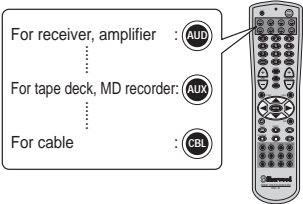
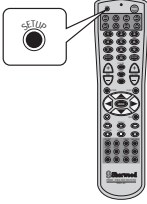
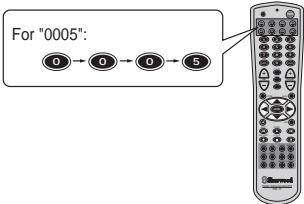
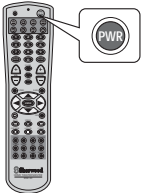
<p><b>1</b> Turn on the component you want to control.</p>	<p><b>2</b> Find the setup codes according to the type and the brand name of your component, referring to "MANUFACTURER'S CODES" in the operating manual of this remote control.</p>
<p><b>3</b> Press the corresponding COMPONENT button. Example) When entering "0005" in the memory of "AUX" button for Sherwood MD recorder.</p> 	<p><b>4</b> Press and hold down the SETUP button until the LED flickers twice, then release the SETUP button.</p> 
<p><b>5</b> Enter the first four-digit code for your component.</p>  <ul style="list-style-type: none"> <li>• If entering is performed correctly, the LED will flicker twice.</li> </ul> <p>Note: If the LED did not flicker twice, then repeat the above steps 3 to 5 and try entering the same code again.</p>	<p><b>6</b> Press the POWER button, aiming the remote control at the remote sensor on the component.</p>  <ul style="list-style-type: none"> <li>• Your component will be turned off.</li> <li>• If it does not respond, repeat the above steps 2 to 5, trying each code for your component until you find one that works. If it still does not work, try searching for the code using "SEARCHING FOR YOUR CODE" in the operating manual of this remote control.</li> </ul> <p>Notes:</p> <ul style="list-style-type: none"> <li>• If the components do not have a POWER button, press the PLAY button.</li> <li>• Although each setup code is designed to work with many different modes, certain codes may not work with some models.(Also, certain codes may only operate some of the functions available on a given model.)</li> <li>• When operating a Sherwood CD player or tape deck using the system remote control, aim the remote control at the REMOTE SENSOR on this receiver. However, in case of Sherwood DVD player and MD recorder, aim it at the REMOTE SENSOR on the corresponding component.</li> </ul>
<p><b>7</b> Repeat the above steps 1 to 6 for each of your components.</p>	

# Operations

Note : Before operating this receiver with the supplied remote control, refer to “Universal Remote Control” on page 10 for details about operation.

ENGLISH

## LISTENING TO A PROGRAM

### Before operation

- Enter the standby mode.

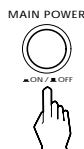

- The STANDBY button lights up in red. This means that the receiver is connected to the AC mains and a small amount of current is retained to support the memorized contents and operation readiness.
- To switch the power completely off, push the POWER switch again.
- The power is cut off and the STANDBY light goes off.

1

In the standby mode, turn the power on.

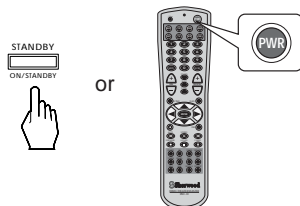

- Each time the STANDBY button on the front panel or the POWER button on the remote control is pressed, the receiver turns on to enter the operating mode (the STANDBY button lights up in green) or turns off to enter the standby mode (the STANDBY button lights up in red).
- In the standby mode, if one of the INPUT SELECTOR buttons is pressed, the receiver turns on automatically and the desired input is selected.

2

Switch the speakers on.



- The SPEAKER indicator lights up on the display and sound can be heard from the speakers connected to the speaker terminals.
- When using headphones for private listening, press the SPEAKER button again to switch the speakers off.

3

Select the desired input source.

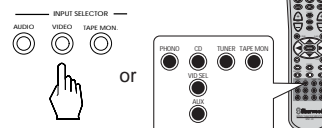

- Each time the “AUDIO” button is pressed, the input source changes as follows;  
 → PHONO → TUNER → CD PLAYER → AUX  
 (frequency display)
- Each time the “VIDEO” or “VID SEL” button is pressed, the input source changes as follows;  
 → VIDEO 1 → VIDEO 2 → ----- → VIDEO 5
- When the TAPE MONITOR button is set to ON so that “TAPE MON” lights up, other inputs can not be heard from the speakers.  
 To listen to an input source other than TAPE MONITOR, be sure to set the TAPE MONITOR button to off.

### TAPE MONITOR function

You can connect either a tape deck or a graphic equalizer to the receiver’s TAPE MONITOR jacks.

To listen to the component connected to these jacks, set the TAPE MONITOR button to on.

If you connect a 3-head tape deck, you can monitor the actual recording, not the source sound.

For further details, refer to the operating instructions of the component connected.

- When selecting the 6.1 CH DIRECT as desired

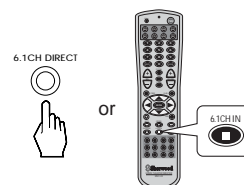

- 6.1 CH DIRECT is displayed and the 7 separate analog signals from a decoder or DVD player connected to this unit will be heard. You can use the tone controls and volume control to adjust the signal. (If the TAPE MONITOR button is on, it will automatically be set to off.)
- To cancel the 6.1 CH direct function, press the 6.1 CH DIRECT button again or select the desired input source.
- These 7 separate analog signals can be heard, only. They cannot be recorded.

**When CD, TAPE MON or VIDEO 1~VIDEO 4 is selected**

**4** Select the digital or the analog input connected as desired.

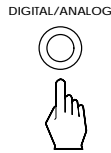

- Each time this button is pressed, the corresponding input is selected as follows;

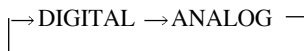

- To listen to DTS or Dolby Digital program sources in the 2-CH downmix mode (the stereo mode), the digital input must be selected. (For details, refer to “Downmixing into 2 front channels” on page 22.)
- When PHONO, TUNER, VIDEO 5 or AUX is selected as an input source, the analog input is selected automatically.

■ Note:

- When the selected digital input is not connected or has no sound, “DIGITAL” flickers indicating the lack of sound. (refer to “ENJOYING SURROUND SOUND” on page 19.)

**5** Operate the selected component for playback.

- To play back the program sources in surround sound, refer to “ENJOYING SURROUND SOUND” on page 19.

**6** Adjust the (overall) volume.

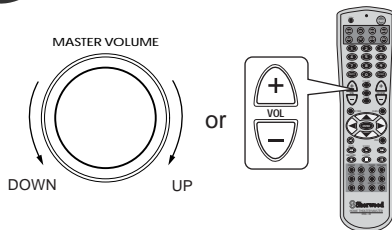

**Adjusting the tone (bass and treble)**

**7** Enter the tone mode.



- “DIRECT ON” or “DIRECT OFF” is shown for 5 seconds.

**8** Select the tone mode as desired.

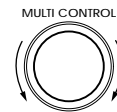

- Each time the MULTI CONTROL knob is rotated, the tone mode changes as follows:

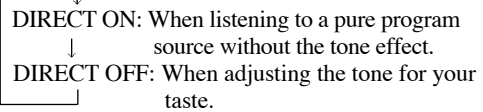

- When “DIRECT ON” is selected.
- “DIRECT” lights up, meaning the tone direct function is activated and the sound that bypasses the tone circuitry will be heard.
- To cancel the tone direct function, select “DIRECT OFF” performing the above steps 7 and 8.
- When “DIRECT OFF” is selected.

1) Select the tone mode as desired.



- Each time this button is pressed, the mode changes as follows;



2) At the desired tone, adjust as desired.

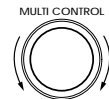

- In general, we recommend the bass and the treble to be set to 0(flat) level.
- To complete tone adjustment, repeat the above steps 1) and 2).

■ Notes:

- If the tone display disappears, start from the step 7 again.
- Extreme settings of the tone controls at high volume may damage your speakers.
- In DTS or Dolby Digital modes, the tone controls cannot be adjusted and the tone direct function is activated automatically .

**9** To compensate for edgy or shrill movie sound tracks.

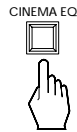

- “CINEMA-EQ ON” will scroll on the display.
- Press it again to cancel, then “CINEMA-EQ OFF” will scroll.

**10** To mute the sound.

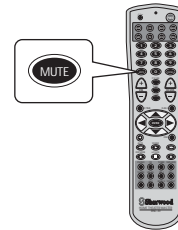

- “MUTE” lights up.
- To resume the previous sound level, press MUTE again.

**11** To listen with the headphones.



- Press the SPEAKER button to off.
- When listening to DTS or Dolby Digital program sources, if the headphones are plugged in and the SPEAKER button is set to off, the 2-CH downmix mode will be selected automatically. (For details, refer to “Downmixing into 2 front channels” on page 22.)



## SURROUND SOUND

- This unit incorporates a sophisticated Digital Signal Processor that allows you to create optimum sound quality and sound atmosphere in your personal Home Theater.

### Surround modes

This unit has 9 different surround modes to allow you to enjoy surround sound with various program sources: DTS, DOLBY DIGITAL, DOLBY PRO LOGIC, THEATER, HALL, STADIUM, CHURCH, 6.1 CH SURROUND, TruSurround.

**DTS (Digital Theater System)** : Allows you to enjoy 5.1(or 6) discrete channels of high quality digital audio from DTS program sources bearing the “” trademark such as laser discs, DVD and compact discs, etc. DTS Digital Surround delivers up to 6 channels of transparent audio(which are identical to the original masters) and results in exceptional clarity throughout a true 360° sound field.

- Manufactured under license from Digital Theater Systems, Inc. US Pat. No. 5,451,942 and other world-wide patents issues and pending. “DTS” and “DTS Digital Surround” are trademarks of Digital Theater Systems, Inc. © 1996 Digital Theater Systems, Inc. All rights reserved.

Note : The DTS program sources should be played back in the DTS mode. If not, no sound or sound like continuous noise will be heard.

**DOLBY DIGITAL** : Allows you to enjoy up to 5.1 channels of digital surround sound from Dolby Digital program sources bearing the “” trademark such as laser discs, DVD’s etc.

Dolby Digital provides better sound quality, improved dynamic range and great sense of direction, compared with the conventional Dolby surround. Now, you are able to enjoy real Home Theater sound in your home.

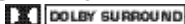
**DOLBY PRO LOGIC** : This unit incorporates the Dolby Pro Logic Surround Decoder which has the same functions for playback as movie theaters and gives a theater-like experience in your home, naturally reproducing the audio sound field. Use with Dolby Pro Logic program sources bearing the “” trademark such as video cassette tapes or laser discs.

- Manufactured under licence from Dolby Laboratories. “Dolby”, “Pro Logic”, and the double-D symbol are trademarks of Dolby Laboratories. Confidential Unpublished Works. © 1992-1997 Dolby Laboratories. All rights reserved.

**THEATER** : This mode provides the effect of being in a movie theater when watching a movie source that has a stereo sound track.

**HALL** : This mode provides the ambience of a concert hall for classical music sources such as orchestral, chamber music or an instrumental solo.

**STADIUM**: This mode provides an expansive sound field. For sources like a rock concert or athletic event you can enjoy a true stadium effect.

**CHURCH**: This mode provides the ambience of a church for baroque, string orchestral and choral group music.

**6.1 CH SURROUND** : This mode extracts the rear center signal from the rear left and right signals and reproduce it as well as the original multichannel signals during playback of 5.1 CH program sources such as DTS, Dolby Digital, etc.

**TruSurround**: TruSurround employs sophisticated digital processing to create the illusion of five “phantom” speakers. Therefore, this mode allows you to experience a realistic multichannel experience from any multichannel audio source and a original three-dimensional sound field from any stereo audio source, through just a single pair of front speakers.

- TruSurround and the  symbol are trademarks of SRS Labs, Inc. TruSurround technology is incorporated under license from SRS Labs, Inc.
- When the 6.1 CH DIRECT INPUTS are connected to the 6.1(or 6) CH decoder for a surround sound(such as Dolby Digital or DTS, etc.), you can enjoy the corresponding surround sound, too. (For details, see the operator’s manual of the component to be connected.)

### Delay time

When the (front)center speaker or the rear speakers is(are) closer to the listener than the front speakers, the sound from the (front)center speaker or the rear speakers can arrive at the listener's ears earlier than the sound from the front speakers.

In this case, the imaging is not as sharp and stable as it could be.

For audible improvement, the sound from (front)center speaker can be delayed with the center delay time setting to synchronize the sound from the front and the (front)center speakers and the sound from the rear speakers can be also delayed with the rear delay time setting so that the sound from the front and the rear speakers will be heard at the same time.

The optimum delay time depends on the speaker placement in your room.

- It is adjustable in Dolby Digital and Dolby Pro Logic modes only.(For details, refer to "In Dolby Digital or Dolby Pro Logic mode, adjusting delay times of the speakers" on page 21.)

### Speaker placement

To obtain the best surround sound effect in your home, place the speakers as follows;

- Front speakers: Place each front speaker about 1 m (40") from the TV set.
- Front Center speaker: Place the center speaker either above or below the TV set to assure a good match between the audio and video of the center channel program.
- Rear speakers: Place the rear speakers approximately 1 m above the ear level of a seated listener on the direct left and right of them or slightly behind.
- Subwoofer: Reproduces powerful deep bass sounds. Place a powered subwoofer anywhere in the front as desired.
- Rear center speaker: Place the rear center speaker behind a seated listener at even level with the rear speakers.
- The ideal surround system needs all the speakers listed above.( However, the rear center speaker can be used for 6.1 CH Surround(as a surround mode) or 6.1 CH DIRECT(as an input source) only.)

To accurately reproduce DTS digital surround, center and rear speakers as well as front speakers should be full range speakers.

- To enjoy the surround sound best, the speakers to be connected are as follows;

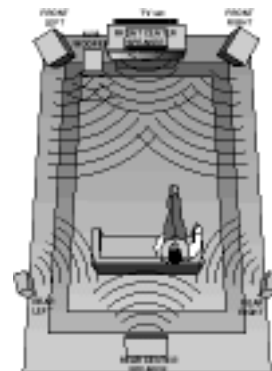

Speakers \ Modes	6.1 CH SURROUND	DTS	Dolby Digital	Dolby Pro Logic	TruSurround	Other Surround	Stereo	6.1 CH DIRECT
Front	Yes	Yes	Yes	Yes	Yes	Yes	Yes	Yes
Front Center	Yes	Yes	Yes	Yes	-	Yes	-	Yes
Rear	Yes	Yes	Yes	Yes	-	Yes	-	Yes
Rear Center	Yes	-	-	-	-	-	-	Yes
Subwoofer	Yes	Yes	Yes	Optional	Optional	Optional	Optional	Yes

Note: To avoid interference with the TV picture, use only magnetically shielded front left, right and center speakers.

## ENJOYING SURROUND SOUND

- Surround sound effect will not work properly if the signal passes through a graphic equalizer. Please refer to your equalizer operating instructions for guidance on switching off (or defeating) the equalizer.

1

Select the desired surround mode.

- When selecting the DTS or Dolby Surround mode.

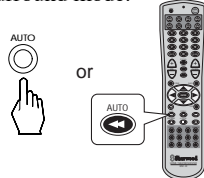

- When playing program sources bearing the “”, “” or “” trademark, etc. such as video, DVD or LD software, the DTS, Dolby Digital or Dolby Pro Logic mode is selected automatically according to the input signal.
- When playing Dolby Digital program sources encoded into the 2 channel format, the Dolby Pro Logic mode or the Dolby Digital mode is automatically selected according to the encoding process. (In case that the Dolby Digital mode is automatically selected, pressing the AUTO button allows this unit to be switched to the Dolby Pro Logic mode.)
- To enjoy the DTS or Dolby Digital mode, be sure that the program source and the corresponding digital input are selected correctly. If not, no sound will be heard.
- When selecting a surround mode among Theater, Hall, Stadium, Church, 6.1 CH Surround, TruSurround modes.

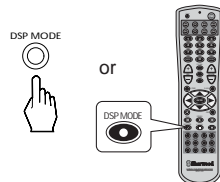

- Each time the DSP MODE button is pressed, the surround mode changes as follows:  

THEATER	→	HALL	→	STADIUM
TruSurround	←	CHURCH		
- In the DTS or Dolby Digital mode only, each time this button is pressed, the surround mode changes as follows:  

6.1 CH SURROUND	→	TruSurround
-----------------	---	-------------
- When the 6.1 CH DIRECT is selected as an input source, the surround mode cannot be selected.
- When canceling the surround mode for normal stereo operation.

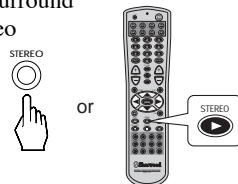

### Adjusting the speaker settings

- This receiver is equipped with circuitry that allows the use of a wide range of speaker systems.
- This circuitry works by redirecting the bass frequencies or the entire channel to speakers that are capable of reproducing them.
- When a Large or full range speaker capable of deep bass response is used for one of the channels, that channel should be set to L.
- When a small or satellite speaker with limited bass capability is used, that channel should be set to S. Deep bass from that channel will be redirected to the main left and right speakers or to the subwoofer.
- When there is no speaker available, that channel should be set to N. All the information in that channel will be redirected to other available speakers.

2

Press the SPEAKER MODE button for more than 2 seconds to enter the front-center-rear speaker mode.



- The front-center-rear speaker setting is displayed.
- When the 6.1 CH DIRECT is selected as an input source or “ANALOG” is selected as signal input in the stereo mode, the speaker mode function cannot be available.

3

Select the desired speaker setting.

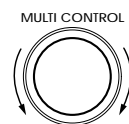

- Each time the MULTI CONTROL knob is rotated, one of 9 different speaker settings is selected and displayed for 8 seconds as follows:  
FL-CL-RL, FL-CL-RN, FL-CN-RL,  
FL-CS-RN, FL-CN-RS, FS-CS-RS,  
FS-CS-RN, FS-CN-RS and FL-CS-RS
- F stands for Front Speakers, C for Center Speaker, R for Rear Speakers, L for Large, S for Small and N for None.
- Large Speakers are capable of deep bass response and typically have one driver with a cone that 10” (25 cm) or larger.

4

Enter the subwoofer mode while it is displayed.



- If the speaker setting display disappears, start from the above step 2 again.

5

Select the desired subwoofer setting.

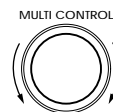

- Each time the MULTI CONTROL knob is rotated, the subwoofer setting changes and is displayed for 8 seconds as follows;

SUB W(oofer) - N(o) : When not using a powered subwoofer.  
 ↓  
 SUB W(oofer) - Y(es) : When using a powered subwoofer.

- If the front speaker is set to “S”, the subwoofer is automatically set to “Y”.

6

Memorize the speaker setting while it is displayed.



- The desired speaker settings are memorized.
- If the subwoofer setting display disappears, start from the above step 2 again.

### Checking the speaker setting



- Each time this button is pressed briefly, the current front-center-rear speaker or subwoofer setting is displayed.

### Adjusting each channel level

7

Select the desired channel.



OR



- Each time this button is pressed, the corresponding channel is selected and displayed for 3 seconds as follows;

→FRONT - L → CENTER(or FRONT-C) →FRONT - R  
 ←SUBWOOFER ←REAR -L(←REAR-C) ← REAR - R  
 ( ): When the 6.1 CH DIRECT is selected as input source.

- According to the surround mode or the speaker setting(N(one) or N(o)), center, rear or subwoofer channel will not be selected.

8

Adjust the level of the selected channel as desired.

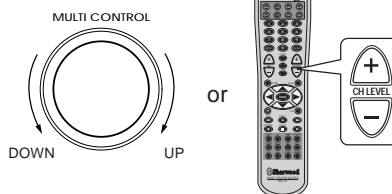

- If the channel display disappears, start from the above step 7 again.

9

Repeat the above steps 7 and 8 to adjust the levels of the other channels.

### Adjusting each channel level using test tones

- In the surround modes only other than the TruSurround mode, the volume level of each channel can be adjusted using the test tone function.
- Note: When 6.1 CH DIRECT is selected as an input source, the test tone function is not available.

**10** Engage the test tone mode by pressing the TEST TONE button on the remote control.

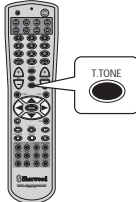

- The test tone will cycle from channel to channel and will be heard from each speaker for 2 seconds as follows:
  - Front Left → Center → Front Right
  - ← SUBwoofer ← Rear Left ← Rear Right ←
- Speakers set to “N” are not available and will not be heard.

**11** Perform the adjustments in steps 7 to 9 in “Adjusting each channel level” until the sound from each speaker is perceived to be equally loud.

**12** Cancel the test tone function.

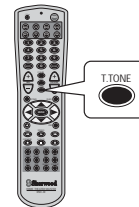

### In Dolby Digital or Dolby Pro Logic mode, adjusting delay time of the speakers

**In the Dolby Digital mode**, the optimum performance of your system occurs when the sound from all five speakers arrives at your primary listening position at the same time. If all speakers are equidistant from the main listening position, set the following delay.

- (Front) center delay time: 0 mS, Rear delay time: 0 mS
- If the (front) center speaker is closer to your prime listening position than the average distance to the left and right main speakers add 1 mS of (front) center channel delay for each foot of difference. The maximum is 5 mS.
  - If the surround speakers are closer to your main listening position than the main left and right speakers add 5 mS of surround channel delay for each 5 feet of difference. The maximum is 15 mS.

**In Dolby Pro Logic mode**, rear channel delay can be adjusted to add spaciousness to the presentation and to minimize any sibilant leakage into the surround channels. If the surround speakers are the same distance from your primary listening position as your main left and right front speakers, set the Rear Delay time at 15 mS.

If the surround speakers are closer to your main listening position than the main left and right speakers, your receiver allows you to optimize the arrival time of the sound from your speakers. This can help focus the audio image and add enjoyment to your home theater experience.

Measure the distance from the prime listening position to each of the speakers to the nearest foot.

- Add 5 mS of surround channel delay for each 5 feet of difference. The maximum is 30 mS.

**13** Check the current delay time.

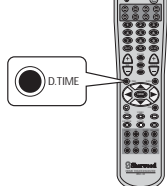

- The current delay time will be displayed for 5 seconds.
- In the Dolby Digital mode, only, the (front) center delay is adjustable and the corresponding delay time is also displayed.

**14** Adjust the delay time.

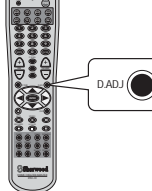

- Each time this button is pressed, the delay time changes in regular steps.
- If the delay time disappears, please start again from step 13.

**15** In Dolby Digital mode, please repeat the above steps 13 and 14 to adjust the rear delay time.

- In the 6.1 CH Surround mode while playing the Dolby Digital program source encoded into multichannel format only, the delay time can be adjusted, too.

## Downmixing into 2 front channels

- Allows the multichannel DTS or Dolby Digital signal to be reproduced through only two speakers or through headphones.
- When playing the DTS or Dolby Digital program sources, press the STEREO button.

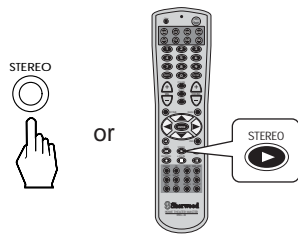



- The “STEREO” and “DTS” or “DOLBY DIGITAL” indicators light up indicating that the program has entered the 2-CH downmix mode and the 5 discrete channels (left front, center, right front, left surround and right surround) are mixed down to the 2 front channels.

- To cancel the 2-CH downmix mode, select the desired surround mode.
- When play is stopped or interrupted, etc., the 2-CH downmix mode is not canceled even though the “STEREO” and “DTS” or “DOLBY DIGITAL” indicators go out.
- DTS and Dolby Digital multi-channel program material will be heard automatically in the 2-CH downmix mode if headphones are plugged in and the SPEAKER button is set to off. However, only the DTS or DOLBY DIGITAL indicator will be illuminated. Unplugging the headphones and setting the SPEAKER button to on will restore the previous mode.

## LISTENING TO RADIO

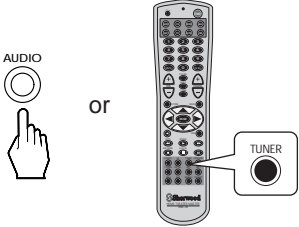
- For some countries in the southeast asia, etc., AM frequency step of 10 kHz may be changed to 9 kHz according to the countries. To change to 9 kHz, do the following procedure.
- 1. Press the STANDBY button on the front panel while receiving AM broadcasts.
- 2. Press the STANDBY button while keeping the BAND button on the front panel pressed. To change to 10 kHz, do this procedure again.

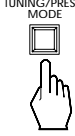
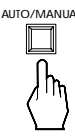
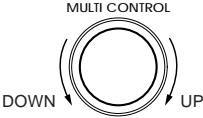
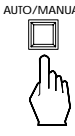
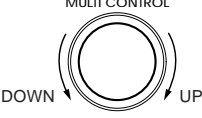
<p><b>Auto tuning</b></p> <p><b>1</b> Select the tuner.</p> 	<p><b>2</b> Select the desired band.</p>  <ul style="list-style-type: none"> <li>• Each time this button is pressed, the band is changed to FM or AM.</li> <li>• When pressing the BAND button without first selecting TUNER, the tuner will be selected automatically.</li> </ul>
<p><b>3</b> Select the tuning mode.</p>  <ul style="list-style-type: none"> <li>• Each time this button is pressed, the mode changes as follows;</li> </ul> <p>↳ Tuning mode : “PRESET” goes off.      ↳          ↳ Preset mode : “PRESET” lights up.      ↳</p>	<p><b>4</b> Select the auto tuning mode as desired.</p>  <ul style="list-style-type: none"> <li>• Each time this button is pressed, the mode changes as follows;</li> </ul> <p>↳ Auto tuning mode : “AUTO” lights up.      ↳          ↳ Manual tuning mode : “AUTO” goes off.      ↳</p>
<p><b>5</b> Find the desired station.</p> 	<ul style="list-style-type: none"> <li>• The tuner will now search until a station of sufficient strength has been found. The display shows the tuned frequency and “TUNED”.</li> <li>• If the station found is not the desired one, simply repeat this operation.</li> <li>• Weak stations are skipped during auto tuning.</li> </ul>
<p><b>Manual tuning</b></p> <ul style="list-style-type: none"> <li>• Manual tuning is useful when you already know the frequency of the desired station.</li> </ul> <p><b>1</b> Perform the steps 1~3 in “Auto tuning” procedure and select the manual tuning mode as desired.</p>  <ul style="list-style-type: none"> <li>• Then “AUTO” goes off.</li> </ul>	<p><b>2</b> Rotate the MULTI CONTROL knob repeatedly until the right frequency has been reached.</p> 

### Presetting radio stations

- You can store up to 30 preferred stations in the memory.

1

Tune in the desired station with auto or manual tuning.

2

Press the MEMORY/ENTER button.



- “MEMORY” flickers for 5 seconds.

3

Select the desired preset number (1~30) and press the MEMORY/ENTER button.

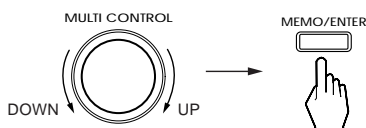

- When using the NUMERIC buttons on the remote control.

Examples)

For “3” :

within 2 seconds

For “15” : →

- The station has now been stored in the memory.
- When using the NUMERIC buttons, the station is stored automatically without pressing the MEMORY/ENTER button.
- A stored frequency is erased from the memory by storing another frequency in its place.
- If “MEMORY” goes off, start again from step 2, above.

4

Repeat the above steps 1 to 3 to memorize other stations.

#### ■MEMORY BACKUP FUNCTION

The following items, set before the receiver is turned off, are memorized.

- INPUT SELECTOR settings
- Surround mode settings
- Preset stations, etc.

Note : If the electricity fails or the AC input cord is disconnected for about 2 weeks. All memorized functions will be lost. Please enter them into memory again.

### Tuning to preset stations

1

After selecting the tuner as input source, select the preset tuning mode.

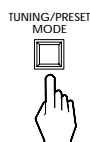

- Then “PRESET” lights up.

2

Select the desired preset number.

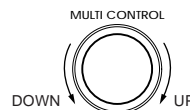

- When using the NUMERIC buttons on the remote control.

Examples)

For “3” :

within 2 seconds

For “15” : →

- When selecting the desired preset number with the NUMERIC buttons, the desired preset station will be tuned to automatically without first selecting the preset tuning mode.



### Listening to FM stereo broadcasts

- While listening to FM broadcasts.



- Each time this button is pressed, the FM mode changes as follows;

→ Stereo mode : "STEREO" lights up.      ←  
← Mono mode : "STEREO" goes off.      →

- When FM stereo broadcasts are poor because of weak broadcast signals, select the FM mono mode to reduce the noise, FM broadcasts are then reproduced in monaural sound.

### Scanning preset stations in sequence

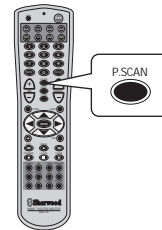

- The receiver will start scanning the stations in the preset sequence and each station is received for 5 seconds.
- At the desired station, press this button again to stop scanning.

## RECORDING

- The analog signals from the 6.1 CH DIRECT inputs as well as the digital signals from the coaxial or optical digital input can be heard but cannot be recorded.
- The volume, tone (bass, treble) settings, etc. have no effect on the recording signals.

## Recording with TAPE MONITOR

1

Select the desired input as recording source except for TAPE MONITOR.

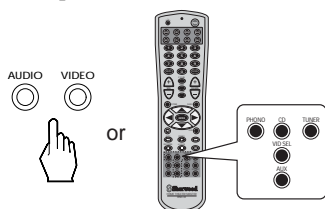

- Be sure that "TAPE MON" goes off.

2

Start recording on the component connected to TAPE MONITOR.

3

Start play on the desired input.

- For tape monitor function, refer to "TAPE MONITOR function" on page 14.

## Dubbing from video components onto VIDEO 1

1

Select VIDEO 2, VIDEO 3, VIDEO 4 or VIDEO 5 as a recording source.

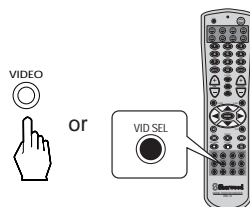

2

Start recording on the VIDEO 1.

3

Start play on the VIDEO 2, VIDEO 3, VIDEO 4 or VIDEO 5.

- The audio and video signals from the VIDEO 2, VIDEO 3, VIDEO 4 or VIDEO 5 will be dubbed onto the VIDEO 1 and you can enjoy them on the TV set and from the speakers.

## Dubbing the sound and image signals separately onto VIDEO 1

Example) When dubbing the VIDEO 2 image signal and the CD sound signal separately onto VIDEO 1.

1

Select VIDEO 2 as a image recording source.

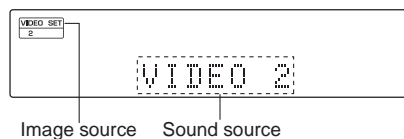
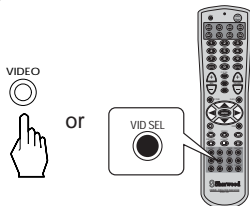

2

Select CD as a sound recording source.

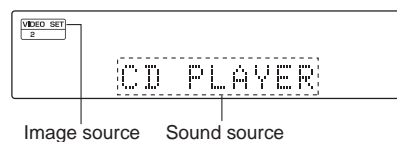
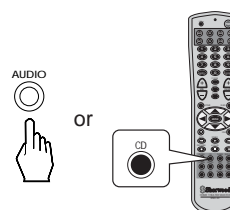



<p><b>3</b> Start recording on the VIDEO 1.</p>	<p><b>4</b> Start play on the VIDEO 2 and the CD respectively.</p> <ul style="list-style-type: none"> <li>The audio signal from the CD and the video signal from the VIDEO 2 will be dubbed and you can enjoy them on the TV set and from the speakers.</li> </ul> <p>Note: Be sure to observe the order of the above steps 1 and 2.</p>
---	--

## DIGITAL AUDIO RECORDING WITH

- When the OPTICAL DIGITAL OUT of this receiver is connected to the OPTICAL DIGITAL IN of an MD or CD recorder, you can enjoy high-quality sound of digital recording, without converting the original signals. Refer to "CONNECTING AUDIO COMPONENTS" and "CONNECTING VIDEO COMPONENTS" on pages 5 and 6 and the operator's manual of the MD or CD recorder.

### Notes:

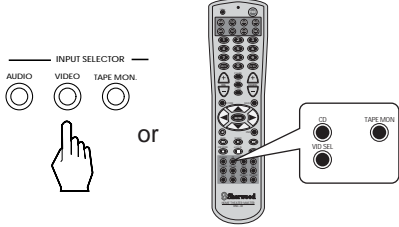
- Digital recording is available for the digital audio program sources such as CDs, MDs, some DVDs, etc.
- In most DVDs as well as some CDs, etc., digital recording may not be available depending on the signal format.

<p><b>1</b> Select a desired input of CD, TAPE MONITOR and VIDEO 1~VIDEO 4 as a recording source.</p> 	<p><b>2</b> Select the desired digital input for the recording signal input.</p> <p>DIGITAL/ANALOG</p>  <ul style="list-style-type: none"> <li>Each time this button is pressed, the corresponding input is selected as follows;</li> </ul> <p>→ DIGITAL → ANALOG</p> <p>Note: When the selected digital input is not connected, "DIGITAL" is flickering, meaning no recording as well as no sound.</p>
<p><b>3</b> Start recording on the component connected to OPTICAL DIGITAL OUT.</p>	<p><b>4</b> Start play on the desired input.</p>

## MULTI SOURCE PLAYBACK

- This function allows enjoying one source in the main room and playing another in a different room at the same time.
- The analog signals from the 6.1 CH DIRECT inputs as well as the digital signals from the coaxial or optical digital input cannot be outputted in the ROOM 2 OUTs, meaning no playback in a different room.

### 1

Select the desired input as a main source.

- When playing video program source in the main room.  
Example) When playing VIDEO 2.
- Select VIDEO 2 as a main source.

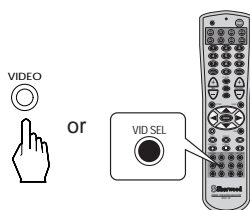

- When an audio program source is selected, the image of the video program source selected previously can be played separately.

■ When playing sound and image sources separately in the main room.

Example) When playing CD as sound source and VIDEO 1 as image source.

- 1) Select VIDEO 1 as image source.

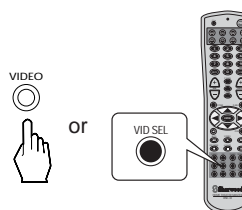

- 2) Select CD as sound source.

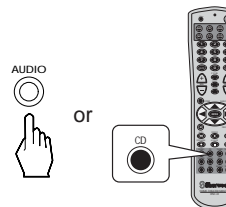

Note: Be sure to observe the order of the above steps 1) and 2).

### 2

Select the desired input as a ROOM 2 source.

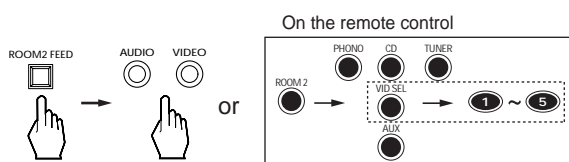

- Press the ROOM 2 FEED button first and select one among "PHONO", "TUNER", "CD", "AUX", "VIDEO 1~5" by pressing the corresponding INPUT SELECTOR button, the selected ROOM 2 source is displayed for 3 seconds as follows; (R2) PHONO, (R2) TUNER, (R2) CD, (R2) AUX, (R2) VIDEO 1~5.
- When selecting one among "VIDEO 1~5" on the remote control, press the ROOM 2 FEED button first, the "VID SEL" button and then the corresponding numeric button among "1~5".
- Only these sources can be played in another room.
- When an audio program source is selected as a ROOM 2 source, the image of the video program source selected previously can be played separately, too.

### 3

Start play on the components related to main source(s) and ROOM 2 source(s) respectively.

- You will enjoy the corresponding sources in the main room and in another respectively.

OTHER FUNCTIONS

**Checking the settings corresponding to each operation**



- Each time this button is pressed, the setting changes and disappears in 2 seconds as follows;
  - Input → Surround mode → Tone → Channel level
  - ← Room 2 ← Dynamic range ← Cinema EQ ← Volume level ←
- The channel level settings are displayed according to the speaker settings.
- If the CHECK button is pressed for more than 2 seconds, the settings are displayed continuously and repeatedly.
- In this case, pressing any button will cancel the check function.

**Compressing the dynamic range (Dolby Digital mode only)**



- This function compresses the dynamic range of previously specified parts of the Dolby Digital sound track (with extremely high volume) to minimize the difference in volume between the specified and non-specified parts. This makes it easy to hear all of the sound track when watching movies at night at low levels.

- Each time this button is pressed, the mode changes and disappears in 3 seconds as follows;

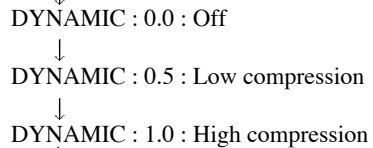

- In some Dolby Digital software, this function may not be available.

**Operating the sleep timer**

- The sleep timer allows the system to continue to operate for a specified period of time before automatically shutting off.
- To set the receiver to automatically turn off after the specified period of time.



- Each time this button is pressed, the sleep time changes and disappears in 3 seconds as follows;

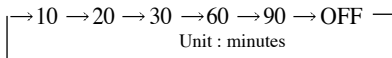

- While operating the sleep timer, "SLEEP" lights up.
- When the sleep time is selected, all display panels of Sherwood components connected by the DIGI LINK III are dimly lit.

**Adjusting the brightness of the fluorescent displays**

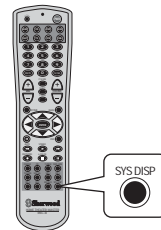

- Each time this button is pressed, the brightness of all fluorescent displays of Sherwood components connected by the DIGI LINK III changes together as follows;

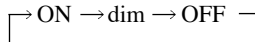

- In the display OFF mode, pressing any button will restore the display ON mode.

### Entering a video label

- This function can be operated only on video input sources such as VIDEO 1~5.

1

Select the desired video input source to enter its label.

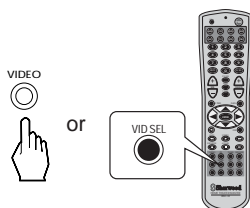

2

Press the VIDEO LABEL button to enter the video label mode.  
Example) When selecting VIDEO 1.



3

Select the character on the flickering digit.

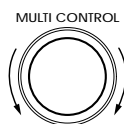

- Each time the MULTI CONTROL knob is rotated, the characters change as follows;

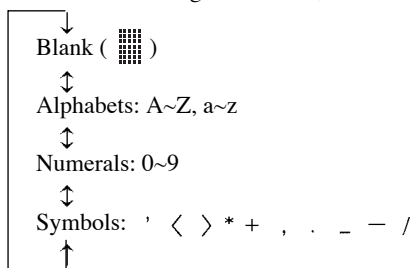

4

Confirm your selection.



- Then the next digit flickers.

5

Repeat the above steps 3 and 4 to enter the desired characters on the next digits.

- You can enter up to 9 characters for each of the video inputs.
- Note: If any button such as "AUDIO", "VIDEO", "6.1 CH DIRECT" button, etc. is pressed while entering a video label, the video label mode will be canceled.

6

Memorize the desired video label.



### Correcting or clearing a video label

1

Select the desired video input source to be rectified or cleared.

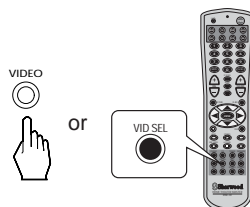

2

Repeat the steps 2~6 in "Entering a video label" procedure.

- To clear a video label, make a blank on each digit and memorize it, then the video label is cleared and its factory video input source will be displayed.
- If the VIDEO LABEL button is pressed for more than 3 seconds, blanks will be made on all the digits at once.

# Using the OSD

This unit incorporates an OSD(On-screen display) function to provide information about basic operation of this unit and to simplify the setup procedures. The OSD function uses a monitor TV connected to this unit as a display and has two kinds of display modes such as current status display and menu screen.

- Notes:
  - When the component video connections are made between the monitor TV and this unit, the OSD function is not available.
  - Any on-screen display shown on the monitor TV will not be recorded onto VIDEO 1.
  - In some countries, this unit allows you to select either NTSC or PAL color system as video format. If it is different from your video components, video softwares, etc., in the standby mode, press the STANDBY button while keeping the AUTO/MANUAL button pressed on the front panel, then the video format is changed to the NTSC or the PAL color system. However, it is fixed to NTSC color system in other countries.

## CURRENT STATUS DISPLAY

This mode shows the status corresponding to each operation.

- The on-screen display will automatically disappear in 5 seconds.
- For examples, there are 2 status displays as follows.

■ When selecting the desired input source.

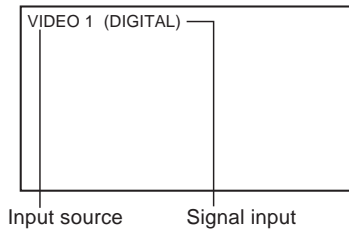

■ When selecting the TEST TONE mode.

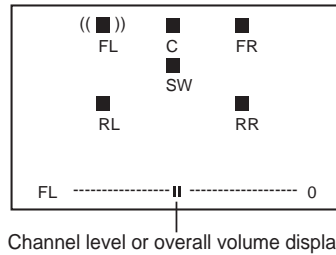

- When adjusting each channel level or overall volume, the volume level display will be shown.
- The test tone display will be shown until the test tone mode is canceled.

## MENU SCREEN

- This function simplifies the setup procedures for items such as the speaker mode, function select, surround mode, delay time and channel level trim.
- The menu screen operation is performed easily with the CURSOR control(▲, ▼, ◀, ▶), ON SCREEN DISPLAY and ENTER buttons.
- The “3”, “7”, “8” and “9” of the NUMERIC buttons do also work as cursor control. In this case, the “3” button stands for the CURSOR UP(▲) button, the “7” for the CURSOR LEFT(◀), the “8” for the CURSOR DOWN(▼) and the “9” for the CURSOR RIGHT(▶).

1

Turn the menu screen on.

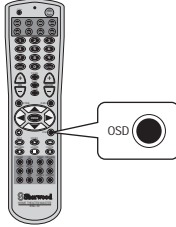

MAIN MENU

- ▶ SPEAKER MODE
- FUNCTION SELECT
- SURROUND MODE
- DELAY TIME
- CH LEVEL TRIM

up/down : MOVE  
OSD : END          ENTER : SELECT

Main menu display

- In the button of the display, “up” stands for the CURSOR UP(▲) button. “down” for the CURSOR DOWN(▼), “OSD” for the ON-SCREEN DISPLAY and “ENTER” for the ENTER button.

- The main menu will be shown.
- To turn the menu screen off, press this button again.

2

Select the desired menu using the CURSOR UP(▲) or DOWN(▼) button.

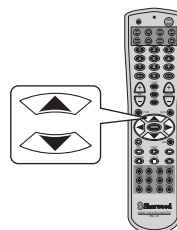

3

Confirm your selection.

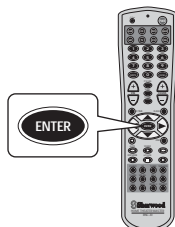

■ When selecting the SPEAKER MODE.

SPEAKER MODE	
▶ SUBWOOFER	- NONE
FRONT	- LARGE
CENTER	- SMALL
REAR	- SMALL
up/down : MOVE	
OSD : BACK	ENTER : SELECT

■ When selecting the FUNCTION SELECT.

FUNCTION SELECT	
▶ DIGITAL INPUT	
VIDEO SELECT	
TONE CONTROL	
ROOM 2 FEED	
up/down : MOVE	
OSD : BACK	ENTER : SELECT

■ When selecting the SURROUND MODE.

SURROUND MODE	
▶ DOLBY DIGITAL	
THEATER	
HALL	
STADIUM	
CHURCH	
TruSurround	
6.1CH SURROUND	
2CH DOWNMIX	
OSD : BACK	
up/down : MOVE	

■ When selecting the DELAY TIME.

DELAY TIME	
	0 . . . 5 10 15mS
▶ CENTER	----    ----
REAR	-----    -----
up/down : MOVE	
OSD : BACK	ENTER : SELECT

■ When selecting the CH LEVEL TRIM.

CH LEVEL TRIM			
	-	0dB	+ dB
▶ FL	-----    -----		0
C	-----    -----		0
FR	-----    -----		0
RR	-----    -----		0
RC	-----    -----		0
RL	-----    -----		0
SW	-----    -----		0
OSD : BACK			

- When adjusting each channel level, use the CURSOR LEFT(◀) and RIGHT(▶) buttons.
- The conditions of each menu may differ according to the speaker, surround mode settings, etc.

4

Select the desired menu or(and) change the condition with the corresponding buttons.

5

Repeat the above steps 2~4 to change the conditions on other menus.



## Troubleshooting Guide

If a fault occurs, run through the table below before taking your unit for repair.

If the fault persists, attempt to solve it by switching the unit off and on again. If this fails to resolve the situation, consult your dealer. Under no circumstances should you repair the unit yourself as this could invalidate the warranty!

PROBLEM	POSSIBLE CAUSE	REMEDY
No power	<ul style="list-style-type: none"> <li>The AC input cord is disconnected.</li> <li>Poor connection at AC wall outlet or the outlet is dead or off.</li> </ul>	<ul style="list-style-type: none"> <li>Connect cord securely.</li> <li>Check the outlet using a lamp or another appliance.</li> </ul>
No sound	<ul style="list-style-type: none"> <li>The speaker wires are disconnected.</li> <li>The master volume is adjusted too low.</li> <li>The MUTE button is pressed to ON.</li> <li>The digital input is not selected.</li> <li>Incorrect selection of input source.</li> <li>Incorrect connections between the components.</li> </ul>	<ul style="list-style-type: none"> <li>Check the speaker connections.</li> <li>Adjust the master volume.</li> <li>Press the MUTE button to cancel the muting effect.</li> <li>Select the digital input .</li> <li>Select the desired input source correctly.</li> <li>Make connections correctly.</li> </ul>
No sound from the rear speakers	<ul style="list-style-type: none"> <li>Surround mode is switched off.(normal stereo mode)</li> <li>Master volume and rear level are too low.</li> <li>Monaural source is used.</li> <li>Rear speaker setting is "N".</li> </ul>	<ul style="list-style-type: none"> <li>Select a surround mode.</li> <li>Adjust master volume and rear level.</li> <li>Select a stereo or surround source.</li> <li>Select the desired rear speaker setting.</li> </ul>
No sound from the (front) center speaker	<ul style="list-style-type: none"> <li>TruSurround, normal stereo mode, etc is selected.</li> <li>(Front) center speaker setting is "N".</li> <li>Master volume and center level are too low.</li> </ul>	<ul style="list-style-type: none"> <li>Select the desired surround mode.</li> <li>Select the desired (front) center speaker setting.</li> <li>Adjust master volume and center level.</li> </ul>
Stations cannot be received	<ul style="list-style-type: none"> <li>No antenna is connected.</li> <li>The desired station frequency is not tuned in.</li> <li>Antenna is in wrong position.</li> </ul>	<ul style="list-style-type: none"> <li>Connect an antenna.</li> <li>Tune in the desired station frequency.</li> <li>Move antenna and retry tuning.</li> </ul>
Preset stations cannot be received	<ul style="list-style-type: none"> <li>An incorrect station frequency has been memorized.</li> <li>The memorized stations are cleared.</li> </ul>	<ul style="list-style-type: none"> <li>Memorize the correct station frequency.</li> <li>Memorize the stations again.</li> </ul>
Poor FM reception	<ul style="list-style-type: none"> <li>No antenna is connected.</li> <li>The antenna is not positioned for the best reception.</li> </ul>	<ul style="list-style-type: none"> <li>Connect an antenna.</li> <li>Change the position of the antenna.</li> </ul>
Continuous hissing noise during FM reception, especially when a stereo broadcast is received.	<ul style="list-style-type: none"> <li>Weak signals.</li> </ul>	<ul style="list-style-type: none"> <li>Change the position of the antenna.</li> <li>Install an outdoor FM antenna.</li> </ul>
Continuous or intermittent hissing noise during AM reception, especially at night.	<ul style="list-style-type: none"> <li>Noise is caused by motors, fluorescent lamps or lightning, etc.</li> </ul>	<ul style="list-style-type: none"> <li>Keep the receiver away from noise sources.</li> <li>Install an outdoor AM antenna.</li> </ul>
Remote control unit does not operate.	<ul style="list-style-type: none"> <li>Batteries are not loaded or exhausted.</li> <li>The remote sensor is obstructed.</li> </ul>	<ul style="list-style-type: none"> <li>Replace the batteries.</li> <li>Remove the obstacle.</li> </ul>
Other Sherwood components do not react to remote control commands.	<ul style="list-style-type: none"> <li>DIGI LINK connections are not made properly.</li> </ul>	<ul style="list-style-type: none"> <li>Make proper DIGI LINK connections.</li> </ul>
A video label cannot be displayed.	<ul style="list-style-type: none"> <li>Malfunction due to external influences such as static electricity, etc.</li> </ul>	<ul style="list-style-type: none"> <li>Clear it using "To clear a video label". (Refer to "Correcting or clearing a video label" on page 30)</li> </ul>
OSD function is not available.	<ul style="list-style-type: none"> <li>Video connections between this unit and the monitor TV are not made correctly.</li> </ul>	<ul style="list-style-type: none"> <li>Make proper video connections.</li> </ul>

# Specifications

## ■ AMPLIFIER SECTION

- Power output, stereo mode, 8 Ω, THD 0.2%, 40 Hz~20 kHz..... 2 × 120 W
- Total harmonic distortion, 8 Ω, 120 W, 1 kHz..... 0.09 %
- Intermodulation distortion  
60 Hz : 7 kHz = 4 : 1 SMPTE, 8 Ω, 120 W..... 0.09 %
- Input sensitivity/impedance  
Phono (MM) ..... 2.5 mV/47 kΩ  
Line (CD, TAPE, VIDEO) ..... 200 mV/47 kΩ
- Signal to noise ratio, IHF "A" weighted  
Phono(MM) ..... 68 dB  
Line (CD, TAPE, VIDEO)..... 98 dB
- Frequency response  
Phono (MM), RIAA, 30~20,000 Hz ..... ±1.5 dB  
LINE (CD, TAPE, VIDEO), 10~110,000 Hz..... +0, -3 dB
- Output level  
TAPE REC, 1 kΩ..... 180 mV  
PRE OUT(Front, Rear, F-Center, R-Center, Subwoofer), 1 kΩ..... 1.0 V
- Bass/Treble control, 100 Hz/10 kHz..... ±10 dB
- Surround mode, only channel driven  
Front power output, 8 Ω, 1 kHz, THD 0.7 %..... 140 W+140 W  
Center power output, 8 Ω, 1 kHz, THD 0.7 %..... 140 W+140 W  
Rear power output, 8 Ω, 1 kHz, THD 0.7 %..... 140 W+140 W

## ■ DIGITAL AUDIO SECTION

- Sampling frequency..... 32, 44.1, 48, 96 kHz
- Digital input level  
Coaxial, 75 Ω..... 0.5 Vp-p  
Optical, 660 nm ..... -15~-21 dBm

## ■ VIDEO SECTION

- Video format..... NTSC
- Input sensitivity(=Output level), 75 Ω  
Video(Composite (normal))..... 1 Vp-p  
S-Video(luminance signal) ..... 1 Vp-p  
(chrominance signal) ..... 0.286 Vp-p  
Component video(R-Y signal)..... 0.5 Vp-p  
(B-Y signal) ..... 0.5 Vp-p  
(Y signal) ..... 1.0 Vp-p

## ■ FM TUNER SECTION

- Tuning frequency range..... 87.5~108 MHz
- Usable sensitivity, THD 3 %, S/N 30 dB..... 17.2 dBf
- 50 dB quieting sensitivity, mono/stereo ..... 25.2/43.2 dBf
- Signal to noise ratio, 65 dBf, mono/stereo..... 70/65 dB
- Total harmonic distortion, 65 dBf, 1 kHz, mono/stereo..... 0.5/0.7 %
- Frequency response, 20 Hz~15 kHz ..... ±2.0 dB
- Stereo separation, 1 kHz..... 40 dB
- Capture ratio..... 4.0 dB
- IF rejection ratio ..... 70 dB

## ■ AM TUNER SECTION

- Tuning frequency range  
10 kHz step..... 520~1710 kHz  
9 kHz step..... 522~1611 kHz
- Usable sensitivity..... 12.5 mV
- Signal to noise ratio..... 51dB
- Selectivity..... 25 dB

## ■ GENERAL

- Power supply..... AC 120 V, 60 Hz
- Power consumption..... 4 A
- Switched AC outlets..... TOTAL 1A, 100 W max.
- Dimensions(W × H × D)..... 440 × 166 × 380 mm(17-3/8 × 6-1/2 × 15 inches)
- Weight(Net) ..... 15 kg(33.1 lbs)

Note: Design and specifications are subject to change without notice for improvements.

O P E R A T I N G I N S T R U C T I O N S



**R-956**  
AUDIO/VIDEO RECEIVER

5707-04723-001-0

## Free Manuals Download Website

<http://myh66.com>

<http://usermanuals.us>

<http://www.somanuals.com>

<http://www.4manuals.cc>

<http://www.manual-lib.com>

<http://www.404manual.com>

<http://www.luxmanual.com>

<http://aubethermostatmanual.com>

Golf course search by state

<http://golfingnear.com>

Email search by domain

<http://emailbydomain.com>

Auto manuals search

<http://auto.somanuals.com>

TV manuals search

<http://tv.somanuals.com>