

ISO 9001
CERTIFIED

shindaiwa

OWNER'S AND OPERATOR'S MANUAL

**SOUND PROOF DIESEL ENGINE
GENERATOR/WELDER**

DGW400DM-380A

Vertical, Water-Cooled
4-Cycle Diesel Engine

Table of Contents	Page
1.Safety Guidelines	2
2.Specifications	5
3.Use	6
4.Parts	6
5.Equipment	7
5-1.Eco Welding	7
5-2.Remote Control(Optional)	7
5-3.Monitor Lamp	8
5-4.Frequency Change	10
5-5.Earth Leakage Relay	11
5-6.Single Phase Breaker for the receptacle circuit only	13
5-7.The Slow-Down Feature	13
5-8.Voltage Adjusting Dial	14
6.Initialization and Pre-check	14
6-1.Checking Engine Oil	14
6-2.Checking Coolant/Water	15
6-3.Checking Fuel	16
6-4.Checking Fuel, Engine Oil and water Leakage	17
6-5.Checking Battery	17
7.Operation	19
7-1.Starting	19
7-2.Stopping	20
8.Welding Operation	21
8-1.Selection-Welding Cable	21
8-2.Polarity	21
8-3.Connection-Welding Cable	21
8-4.Duty Cycle	22
8-5.Welding	23
9.Generator Operation	24
9-1.Output Range	24
9-2.Output Limitation	25
9-3.Operation	26
10.Simultaneous Use of Welding and Generating	28
11.Checking and Maintenance	28
12.Long-term Storage	33
13.Troubleshooting	33
14.Engine Wiring Diagram	35
15.Generator Wiring Diagram	36



CAUTION: Do not operate the Generator/Welder, or any other appliance, before you have read and understood the instructions for use.



Shindaiwa Corporation

Introduction

Thank you for purchasing Shindaiwa Sound Proof Diesel Engine Generator/Welder.

- This user manual was created to ensure the safe operation of this equipment. Therefore, the manufacturer of this equipment strongly recommends that the user follow the instructions herein, to avoid unnecessary accidents and repairs.
- Please operate this equipment after thoroughly reviewing and understanding the contents of this manual.
- Please attach this manual, if the equipment will be sub-leased.
- Please store this manual near the equipment for easy reference.

■Following convention will be used throughout the manual to indicate the degree of cautions.

 Danger	<i>Can cause serious injuries or death.</i>
 Caution	<i>Can cause minor injuries or damage to the equipment or other properties.</i>
<Caution>	<i>Other types of caution</i>

- Even some of the items noted in 『  **Caution** 』 may lead to serious injuries. Please read all item and follow all the safety guidelines.

1. Safety Guidelines

Danger : Suffocation from exhaust fume

- Exhaust fume from the engine contains many elements harmful to human. Do not operate this equipment in poorly ventilated area, such as inside a room or in a tunnel.

Danger : Electric Shock

- Do not touch the output terminals during operation.
- Do not insert metal objects (such as pin or wire) into plug-in receptacles.
- Do not touch wiring or electric parts inside the equipment during operation.
- Before connecting or disconnecting a load cable from output terminals, always turn the circuit breaker to OFF position.
- Before connecting or disconnecting a welding cable from output terminals, stop the engine, and remove the engine key.
- Before performing any equipment check or maintenance, stop the engine, and remove the engine key. A person performing the maintenance should always keep the key.

Danger : Burns

- Do not open the radiator cap while operating this equipment or immediately after stopping the equipment, to avoid sustaining burns from hot vapor.

Danger : Injuries

- Close all doors and place locks during operating this equipment, to avoid injuries by unintentionally touching cooling fan and fan belt.

Caution : Suffocation from exhaust fume

- Do not point the exhaust fume toward pedestrians or building.

Caution : Suffocation from welding fume

- Be sure to wear a fume proof mask in operation, because welding fume contains poisonous gas and dust. Pay attention to the airflow direction and sufficient ventilation also in order to prevent from inhaling the fume.

Caution : Injuries to eyes and skin

- Be sure to wear spark protection glass(es), long-sleeve shirts, gloves, etc. in order to protect eyes and skin from harmful spark in welding.
- Battery fluid contains diluted sulfuric acid. Avoid contact with eyes, skin or on clothing. If the acid comes in contact, especially with eyes, flush with a lot of water, and contact your physician immediately.

Caution : Electric shock

- Do not flush water onto the equipment nor operate it in the rain.

Caution : Explosion

- Do not use the equipment or charge the battery, in the case the battery fluid level is lower than the LOWER level.
- Battery may emit some combustible gas, so keep it away from fire and sparks.

⚠ Caution : Fire

- The equipment uses Diesel Oil as a fuel. When refueling, always stop the engine and keep away from fire. Moreover, always wait until the engine cools down before refueling.
- Always wipe any drip of Diesel fuel or lubrication oil. Do not use this equipment when a leak is found. Repair the equipment before use.
- Temperature around muffler and exhaust can get extremely high. Keep any inflammable items (such as fuel, gas, paint, etc.) away from the equipment.
- Keep any inflammable items and easily burning items away from the place in welding, because welding splashes spatters.
- Always operate this equipment on flat surface and, at least 1 meter away from any objects (wall, box, etc.).
- Do not connect AC output to any indoor wiring.
- Always wait until the equipment cools down, before placing any covering materials for storage.

⚠ Caution : Burns

- Do not touch the engine and muffler during operation and immediately after stopping the equipment, for the temperature can reach extremely high.
- When checking engine oil or changing oil, always stop the engine, and wait until the engine cools down. If you open either the oil gauge or the oil plug during operation, hot oil may cause some injury.
- Be sure to wear leather gloves, apron, shoe covers, eye protection glass(es) (mask), safety shoes, safety cap, and long sleeve shirts, because welding splashes spatters.

⚠ Caution : Injuries

- When lifting the equipment, always use a lift hook. Do not lift a handle, for it may cause equipment to drop due to handle breaking off.
- Always place the equipment on a flat and stable surface, to keep the equipment from sliding. Be sure to lock the wheels for the wheeled models.
- When starting the engine, turn off the connected equipment and set the circuit breaker to OFF position.
- Do not move the equipment during operation.
- When performing equipment check and maintenance, always stop the engine.
- Do not operate the equipment, if the equipment is being modified or if the parts are removed.

■ Location of Warning labels

When the warning labels become unreadable or damaged, place new labels on the appropriate locations, as specified in the following figure.

When ordering the label, use the following part numbers.

Suffocation from exhaust fume (No. 19402-00194)

Suffocation from welding fume (No. 19402-00195)

Electric shock (No. 19402-00192)

Electric shock (No. 19402-00193)

Injuries (No. 19402-00199)

Burns (No. 19402-00201)

Burns (No. 19402-00200)

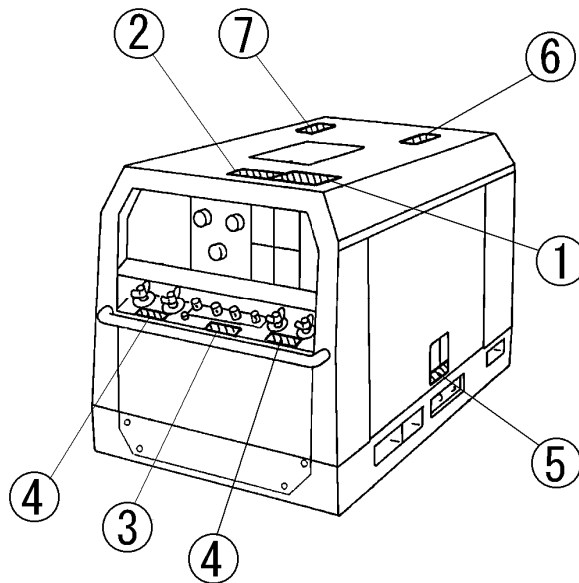

2. Specifications

Model		DGW400DM			
Generating Method		Rotating Field			
Welding Generator	Rated Current (A)		370 / 390		
	Rated Voltage (V)		34.8 / 35.6		
	Duty Cycle (%)		60		
	Rated Speed (min^{-1})		3000 / 3600		
	No Load Voltage (A)		MAX 85		
	Output Change	Single	Current Adj. Range (A)	90 – 380 / 110 - 400	
			Welding Rod (Φ)	2.6 - 8.0	
		Dual	Current Adj. Range (A)	50 – 190 / 55 - 210	
			Welding Rod (Φ)	2.0 - 4.0	
Eco		Current Adj. Range (A)	40 - 240		
		Welding Rod (Φ)	2.0 - 5.0		
AC Generator	Rated Frequency (Hz)		50 / 60		
	Rated Speed (min^{-1})		3000 / 3600		
	Phase		1-Phase	3-Phase	
	Rated Voltage (V)		220-240	380-415	380-415
	Power Factor		1.0		0.8
	Rated Output (kVA)		3	12	15
	Rating		Continuous		
Engine	Model		Kubota D1005		
	Type		Vertical, Water-Cooled 4-Cycle Diesel Engine		
	Displacement (L)		1.001		
	Rated Output ($\text{kW}/\text{min}^{-1}$)		16.5 / 3000 or 19.1 / 3600		
	Fuel		ASTM No.2 Diesel Fuel or Equivalent		
	Lubricant Oil		API Class CC or Higher		
	Lubrication Oil Volume (L)		5.1 (Effective 1.4)		
	Cooling Water Volume (L)		4.3 (Sub Tank Capacity 0.6 L included)		
	Starting Method		Starter Motor		
Battery		55B24L			
Fuel Tank Capacity (L)		37			
Dimension	Length (mm)		1519		
	Width (mm)		700		
	Height (mm)		760		
Dry Weight (kg)		469			

3. Usage

- Arc Welding
- Electric Tools and Home Appliances
- Power Source for lights

⚠ Caution : Damage to the equipment or other properties

- The equipment is designed for the above purposes only. Do not use it for the other purpose. When it will be used for the equipment with the microcomputers control or for the ultra-precision devices, the load may be malfunctioned.
- Whenever connecting to use medical equipment or appliances, be sure to consult with the medical equipment company, doctor or hospital personnel.

4. Parts

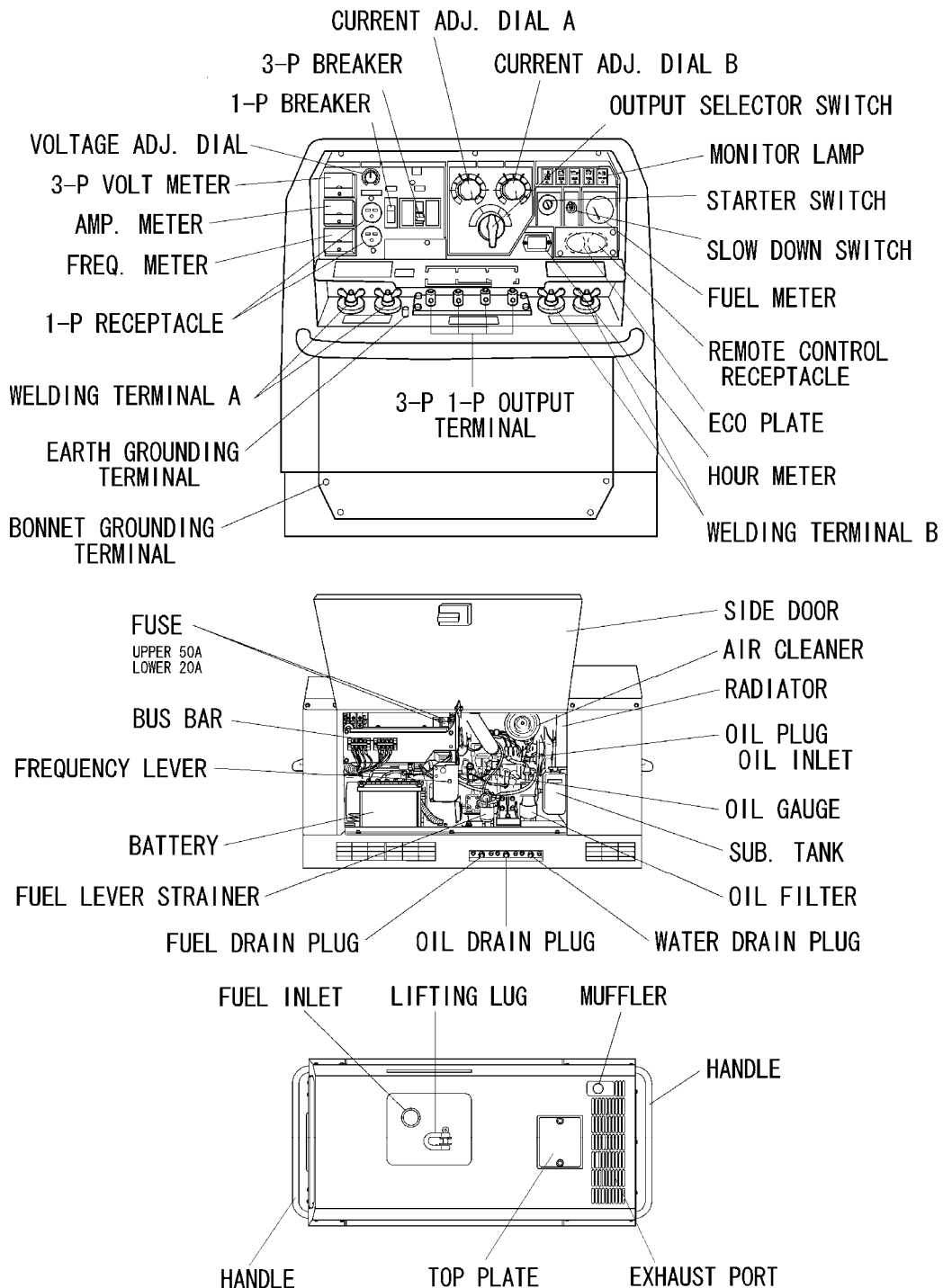

5. Equipment

5-1 Eco Welding

The equipment is incorporated in Eco welding features that are aimed at performing the lower noise, the lower fuel consumption and the lower gas emission than conventional models.

When you turn the selector switch to Eco, you will be able to weld with Max. 5.0mmφwelding rod at the slow down speed.

<Caution>

- When welding is performed, do not turn the output selector switch, which causes the burnout of the switch.
- Eco is designed for welding only. The 3-phase circuit breaker trips and simultaneously the outputs of welding and generating would fall down and you will not do anything when Eco is used for AC power supply.

5-2 Remote Control (Option)

Using the remote control box, the remote control to adjust the welding current makes it possible.

Remote Control Box Connection

- Remove "Eco" plate. (M4 Screw 2 pieces)

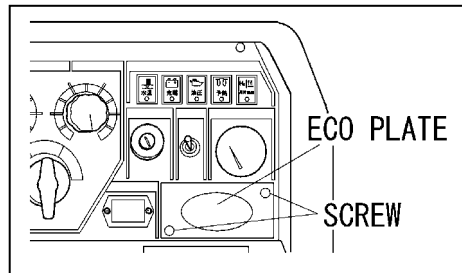

- Insert the plug of the extension cable reel into A side or B side receptacle

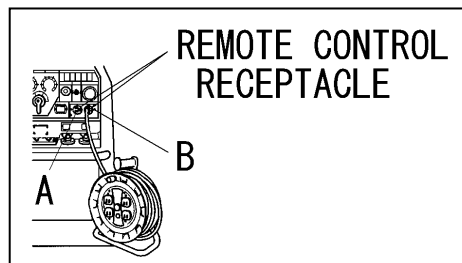

- Insert the plug of the remote control box into the receptacle of the extension cable reel.

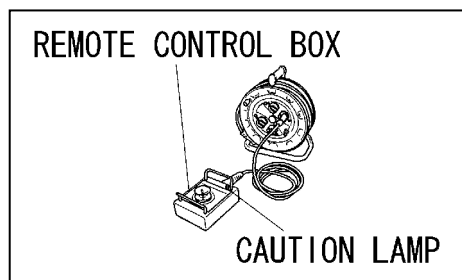

<Caution>

- Never connect the plug of the remote control box to the receptacle of the extension cable reel when the reel is connected to 1-P receptacle.
- Never connect the other loads additionally than the remote control box.
- In the case the extension cable reel is installing the breaker, use the equipment to have turned the breaker ON.

5-3 Monitor Lamp

The equipment is incorporated in monitoring function of WATER TEMP, BATTERY CHARGING, OIL PRESSURE, Hz/OVERHEAT.

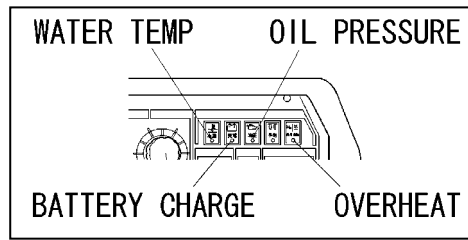

Under normal condition, when the starter switch changes from STOP to RUN, all the lamps of BATTERY CHARGING, OIL PRESSURE and Hz/OVERHEAT turn ON. When the engine starts, all the lamps turn OFF. When abnormality is detected on other than Hz/OVERHEAT, the corresponding monitor lamp will flash, and the engine automatically shutoff.

When the automatic shutoff is engaged, turn the starter switch to STOP position once, and then restart the engine. In the event the automatic shutoff is engaged next time, check which lamp turns ON or OFF and point out where is the abnormality.

(1) Coolant/Water Temperature Monitor Lamp

⚠ Danger: Injuries

- Close all doors and place during operating this equipment, to avoid injuries by unintentionally touching cooling fan and fan belt.

⚠ Danger: Burns

- Do not open the radiator cap while operating this equipment or immediately after stopping the equipment, to avoid sustaining burns from hot vapor.

⚠ Caution: Burns

- Do not touch the engine and muffler during operation and immediately after stopping the equipment, for the temperature can reach extremely high.

When the water temperature rises abnormally, the coolant/water temperature monitor lamp will flash, and the automatic shutoff will be engaged.

When this occurs, check the coolant/water reservoir tank, and replenish if needed.

(Refer to No. 6-2 Checking coolant/water temperature.)

If the water level is normal, there may be a possibility of overloading. Always use the equipment within the rated duty cycle and output power.

(2) Battery Charge Monitor Lamp

When the battery turns unable to be charged during operation, the battery charge monitor lamp will flash and the automatic shutoff will be engaged.

In the event this occurs, consult with the authorized distributor or our engineering section.

<Caution>

- The battery charge monitor cannot detect the degradation of the battery nor the battery fluid level. Check the battery fluid level periodically. (Refer to No. 6-5 Checking Battery)

(3) Oil Pressure Monitor Lamp

⚠ Danger : Injuries

- Close all doors and place locks during operating this equipment, to avoid injuries by unintentionally touching cooling fan and fan belt.

⚠ Caution : Burns

- Do not touch the engine and muffler during operation and immediately after stopping the equipment, for the temperature can reach extremely high.
- When checking engine oil, always stop the engine, and wait until the engine cools down. If you open either the oil gauge or the oil filter cap during operation, hot oil may cause some injury.

When the engine oil pressure drops during operation, the oil pressure monitor lamp will flash, and the automatic shutoff will be engaged.

When this occurs, check the engine oil level, and replenish to the maximum level if needed.

<Caution>

- The engine oil pressure monitor cannot detect the degradation of engine oil itself. Please check the engine oil periodically, and change if needed. (Refer to No. 11. Maintenance.)
- Check the fuse next, when the abnormality, other than WATER TEMP, BATTERY CHARGED OR OIL PRESSURE is detected. If the fuse is burned out, consult with our authorized distributor or our engineering section, because there may be an abnormality of electric/electronic parts or wiring and repairing may be required.

(4) Hz/Overheat Monitor Lamp

- Unless the frequency selector lever position and the bus bars in the equipment are correspondent to each other, Hz/OVERHEAT monitor lamp will turn ON.
- Hz/OVERHEAT monitor lamp may flash in the case the machine is used excessively over the duty cycle.

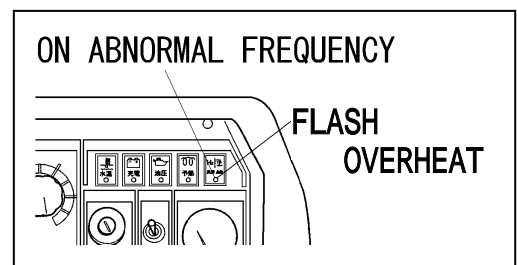

<Caution>

- When Hz/OVERHEAT monitor turns ON, as the output power reduces remarkably, the AC output power can hardly be used.
- There may be a case that the lamp will not flash, depending on the welding type or the weather condition.

5-4 Frequency Change

⚠ Danger : Injuries

- Frequency change should be done, after stopping the engine. Moreover, close doors and place locks during operating this equipment, to avoid injuries by unintentionally touching cooling fan and fan belt.

⚠ Danger: Electric Shock

- Never touch the frequency change bus bar during operation.

⚠ Caution: Burns

- Do not touch the engine and muffler during operation and immediately after stopping the equipment, for the temperature can reach extremely high.

The equipment can be used to 50Hz and 60Hz. Select the frequency according to the load.

Stop the engine.

Open the side door.

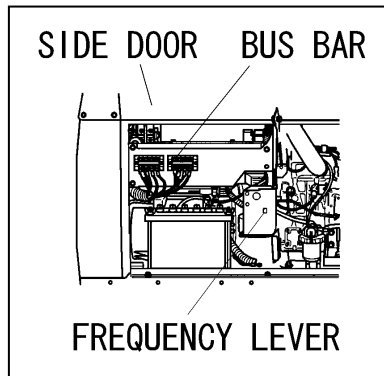

Turn the selector switch and the metal bus bars to the other frequency as per the drawing.

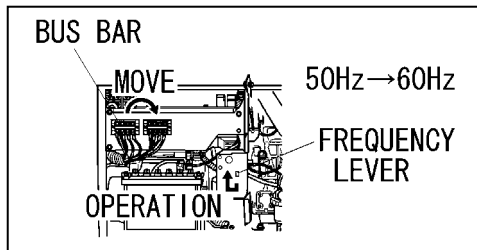
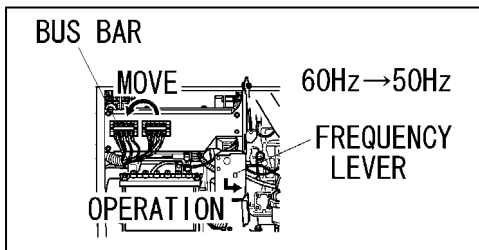

Start the engine. (Refer to 7-1. Starting)

Turn the slow-down switch to OFF. (Refer to 5-7. Slow-Down)

Check the frequency in the frequency meter in the control panel.

5-5 Earth Leakage Relay

⚠ Danger : Electric Shock

- Ground every grounding terminal to the earth as set out in the manual. If even one of all is unconnected by mistake or accident, it will be much more dangerous for human body than the NO RELAY case, because leaking current inevitably goes through the body.
- Even though all the terminals of the loads have been grounded to the earth, the earth grounding terminal and the bonnet (canopy) grounding terminal should be grounded to the earth.
- Grounding should be made after the engine is stopped.
- Whenever the earth leakage relay has activated, you should always repair the leaking place first of all.

The equipment is provided with the earth leakage relay in the 3-Phase Circuit Breaker to detect any leakage arisen due to the troubles as insulation failure of the load while the generator is running. And cutting off the circuit for protection against any accident such as electrical shock resulting from the trouble.

<Caution>

- The earth leakage relays (3-Phase 380V and 1-Phase 220V) activate the AC to the terminals but not to receptacles.
- The 3-phase circuit breaker trips to protect the loads, whenever AC power is used where the selector switch is in the Eco position.

The specifications of the earth leakage relay:

- Rated Sensitive Current: 30mA (or below)
(Grounding resistance: 500Ω or below)
- Sensitive time: Within 0.1 second

(1) Grounding Work

The qualified electrician should perform the grounding work of the following 3 points (500Ω or below).

- The earth grounding terminal in the output terminals
- The Outer Bonnet of the equipment (bonnet grounding terminal)
- The Outer Bonnet of the load

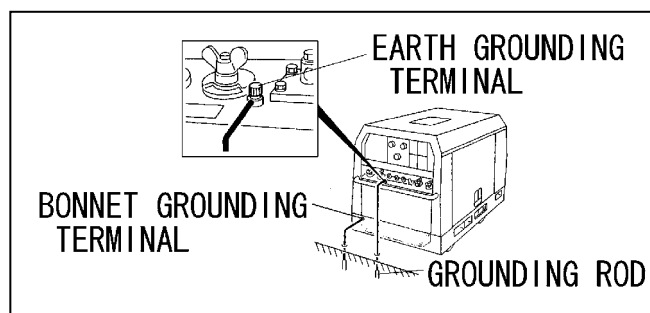

<Caution>

- In the event you cannot ground the generator to the earth, consult with the authorized distributor or our engineering section.

(2) Operation Check

Before operating the equipment, check always if the device can work duly as shown in the following procedure.

Turn the starter switch from STOP to RUN.

Turn (Push-up) the 3-P circuit breaker (lever) to ON position.

Push the test button. The device is found to be normal as the earth leakage indication lamp turns ON and the 3-P circuit breaker positions in the middle of ON and OFF.

Push the reset button. (The earth leakage indication lamp turns OFF.)

Turn (Push-down) the 3-P circuit breaker (lever) to OFF position.

Restore the switch to STOP once, when starting the engine.

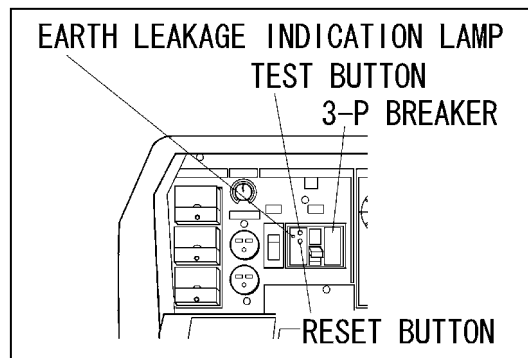

- In the event you cannot complete all steps in the above procedure to the end, the device is out of order. Consult with our authorized distributor or our engineering section to repair.

(3) The Earth Leakage Relay has activated

⚠ Caution : Electric Shock / Injuries

Be sure to disconnect all the loads to the equipment when turning the breakers ON again, after the earth leakage relay has activated.

When the earth leakage relay has activated, the earth leakage indication lamp turns ON and also the 3-P circuit breaker (lever) trips to the middle of ON and OFF. In the case, stop the engine promptly and find the leakage point to repair.

After repairing leakage point(s), proceed with the following restoration steps.

Push the reset button or stop the engine.

Restore (push-down) the 3-P circuit breaker (lever) to OFF position.

By the above procedures, you can reset the breaker to ON position.

<Caution>

When the breaker has tripped to the middle but the lamp does not turn ON simultaneously, the cause to have tripped is OVER-LOAD or the output selector switch is positioned to ECO. Restore as per the procedures No. 9-3 Operation.

5-6 Single Phase Breaker for the receptacle circuit only

⚠ Caution : Electric Shock • Injuries

- Be sure to disconnect all the loads to the generator when turning the breakers ON again, after the 1-Phase Breaker has activated.

Disconnect all the loads.
Turn the breaker to ON.

<Caution>

- Do not exceed the maximum output. Refer to 9-2 Output Limitation.
- The 1-P breaker protects the receptacle circuit only.

5-7 The Slow-Down Feature

The slow-down feature is to set the engine speed low automatically (in about 8 seconds) for the purpose of reducing noise and fuel consumption, whenever no welding operation or electric supply is performed.

In the case of using the SLOW-DOWN feature, turn the slow-down switch to ON. By the condition, the engine automatically moves to high speed, whenever welding operation or electric supply starts.

⚠ Caution : Damage to the equipment or other properties

- Turn always the slow-down switch to OFF, when the load is incorporated with any magnet switch.

<Caution>

- When the load of less than 0.5A is connected to use, the Slow-Down feature does not function sometimes. Therefore, turn the switch to OFF.
- When welding operation or electric supply performs alternately or intermittently, turn the switch to OFF.
- When the output selector switch is positioned to Eco, the engine does not turn to high speed.

5-8 Voltage Adjusting Dial

Adjust the dial whenever the AC Output adjustment is necessary. Set the dial in the center usually.

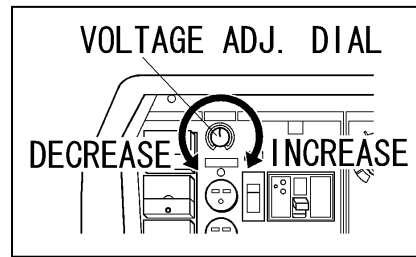

<Caution>

- When raising the voltage, the current is decreasing. (Use the output within the output capacity.)
- In you raise the voltage exceeding the allowable voltage range, which causes the damage to the loads. (Especially using the output terminals connected to the 1-P loads.)

6. Initialization and Pre-check

⚠ Caution : Fire • Burns • Injuries

- When checking engine, always stop the engine, and keep away from fire. Wait until the engine cools down, before performing any checks.

6-1 Checking Engine Oil

When checking for engine oil, be sure to keep the equipment leveled, and insert the oil gauge all the way in.

Prior to starting the equipment, make sure to fill the engine oil to the UPPER line through the oil inlet.

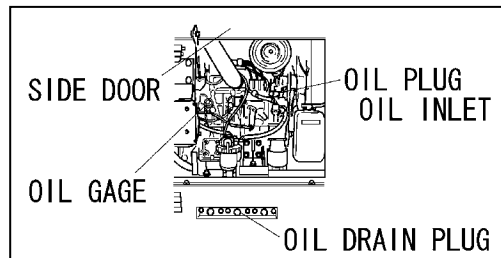

<Caution>

- If the equipment is not leveled, you cannot obtain accurate oil level. Do not overfill (over UPPER line) the engine oil. The excessive amount of engine oil may damage the engine (inside the cylinders)

■ Selecting proper engine oil

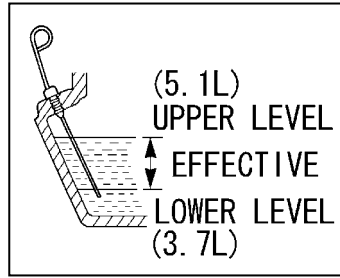

<Caution>

Use the API class CC or higher.

Viscosity and Temperature

Temperature	Over +20	+10 ~ +20	-10 ~ +40
Viscosity	SAE30	SAE20	SAE10W/30

6-2 Checking Coolant / Water

⚠ Danger : Injuries

- Close all doors and place locks during operating this equipment, to avoid injuries by unintentionally touching cooling fan and fan belt.

⚠ Danger : Burns

- Do not open the radiator cap while operating this equipment or immediately after stopping the equipment, to avoid sustaining burns from hot vapor.

⚠ Caution : Burns

- Do not touch the engine and muffler during operation and immediately after stopping the equipment, for the temperature can reach extremely high.

Check to see if the coolant/water level is between FULL and LOW levels in the sub tank. If the coolant/water is below the LOW level, fill the tank and the radiator accordingly.

- (1) Filling to the Reservoir Tank
 Remove the sub tank cap.
 Fill up the sub tank to the FULL level.
 Install the cap back.

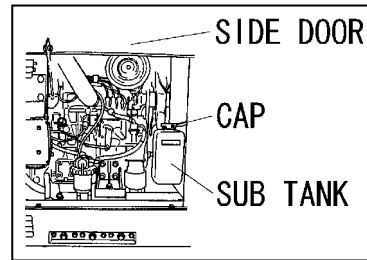

- (2) Filling to the Radiator
 Remove the top plate.
 Remove the radiator cap.
 Fill the radiator up to the top.
 Install the cap back and tighten.
 Reinstall the top plate.

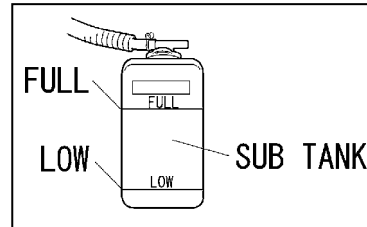

<Caution>

- Use soft water, such as tap water.
- If the ambient temperature is near freezing, use Long Life Coolant (LLC) (30% mixture LLC is filled when shipped from factory)
- Mixture ratio of the coolant should be 30%-45%, depending on the ambient temperature.
- Replace LLC at every year or 2000 hours.

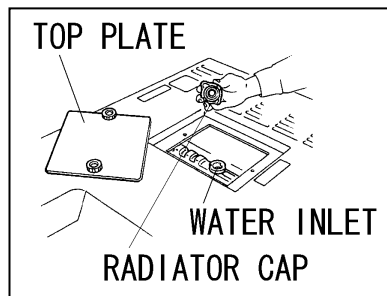

Mixture Ratio (for reference only)

Lowest Ambient Temperature	-15	-20	-30
Mixture Ratio	30%	35%	45%

6-3 Checking Fuel

⚠ Caution : Fire

- Always wipe any drip of fuel. Do not use this equipment when any leak is found. Repair the equipment before use.

Check for the fuel level in the tank. Add if necessary.

<Caution>

- Use Diesel fuel, ASTM D975 No.2-D in the event ambient temperature reaches down to -5 .
- The engine is designed to use either No.1-D or No.2-D Diesel fuel. However, for better economy, use No. 2-D Diesel Fuel whenever possible. At temperatures less than -7□(20), No.2-D fuel may pose operating problems (see “Cold Weather Operation which follows). At colder temperatures, use No.1-D fuel (if available) or use a “winterized” No.2-D (a blend of No.1-D and No.2-D). This blended fuel is usually called No.2-D also, but can be used in colder temperatures than No.2-D fuel which has not been “winterized”. Check with the services stations operator to be sure you can get the properly blended fuel. Note that Diesel fuel may foam during a fill-up. This can cause the automatic pump nozzle to shut off even though your tank is not full.
- Always use the fuel strainer.
- Fill the fuel tank slightly less than the FULL tank.

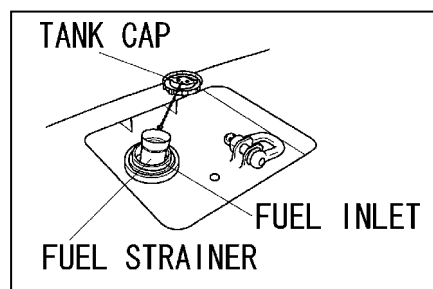

6-4 Checking Fuel, Engine Oil and Water Leakage

⚠ Caution : Fire

- Do not use this equipment when a leak is found. Repair the equipment before use.

Be sure to check any leakage for fuel, oil and coolant/water at the hose connections by opening side doors. Whenever checking any fuel leakage, turn the fuel lever OPEN and be sure to close the fuel lever after checking.

6-5 Checking Battery

⚠ Caution : Injuries to eyes and skin

- Battery fluid contains diluted sulfuric acid. Avoid contact with eyes, skin or clothing.
- If the acid comes to contact, especially with eyes, flush with a lot of water, and contact your physician immediately.

⚠ Caution : Explosion

- Do not use the equipment or charge the battery, in the case the battery fluid level is lower than the LOWER level.
- Battery may emit some combustible gas, so keep it away from fire and sparks.

⚠ Caution : Fire

- Battery may emit some combustible gas, so keep it away from fire and sparks.

Check the fluid level. If the level is near or lower than LOWER level, add distilled water until the fluid level reaches UPPER level.

Make sure that the battery cables are firmly secured to the posts. Tighten the clamps if necessary.

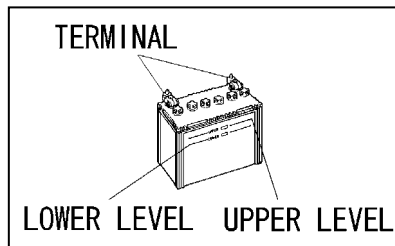

<Caution>

- Check the hydrometer of the battery fluid. If it falls below 1.23, the battery requires recharging. Please consult with our authorized distributor or our engineering section.

■ Replacing battery

Remove the clamp and cable from negative (-) post in the battery.

(Remove always negative side first)

Remove the hold-down clamp from the battery.

Remove the clamp and cable from positive (+) post in the battery.

Remove the battery from the seat.

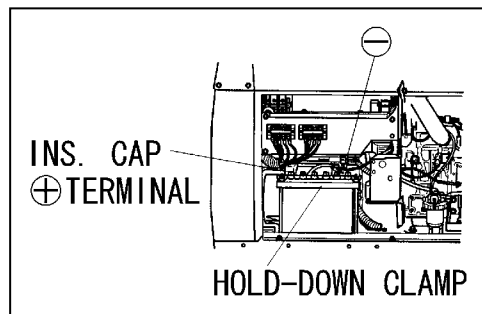

Reinstall a new battery in the reverse order.

(Install always the cable to the positive (+) post in the new battery first.)

<Caution>

- Use the following battery.
55B24L

7. Operation

⚠ Danger : Suffocation from exhaust fume

- Exhaust fume from the engine contains many elements harmful to human. Do not operate this equipment in poorly ventilated area, such as inside a room or in a tunnel.

⚠ Caution : Suffocation from exhaust fume

- Do not point the exhaust fume toward pedestrians or building.

⚠ Caution : Fire

- Temperature around muffler and exhaust can get extremely high. Keep any inflammable items (such as fuel, gas, paint, etc.) away from the equipment.
- Always operate this equipment on flat surface and, at least 1 meter away from any objects (wall, box, etc.)

⚠ Caution : Injuries

- Always place the equipment on a flat and stable surface, to keep the equipment from sliding. Be sure to lock the wheels for the wheeled models.
- Before starting the engine, be sure to disconnect the loads and set the breakers (1-P and 3-P) to OFF position.

7-1 Starting

Turn the breakers (1-P and 3-P) to OFF position.

Turn the fuel lever to OPEN.

Turn the Slow-Down switch to ON.

When the temperature is below -5 ,turn and keep the starter switch to PREHEAT until the preheat lamp turns OFF (about 5 seconds).

Turn the starter switch to START and then the engine starts by the starter motor.

<Caution>

- Do not drive the starter motor for more than 15 seconds successively.
- If you need to restart, wait for 30 seconds or more before retry.

Release the switch, as soon as the engine has started.

<Caution>

- Once the engine has started, never turn the starter switch to START.

Keep the engine idle for about 5 minutes.

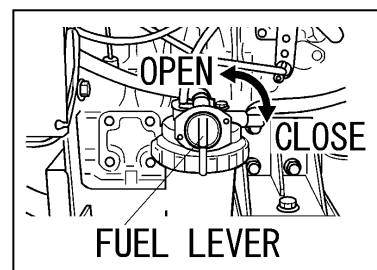
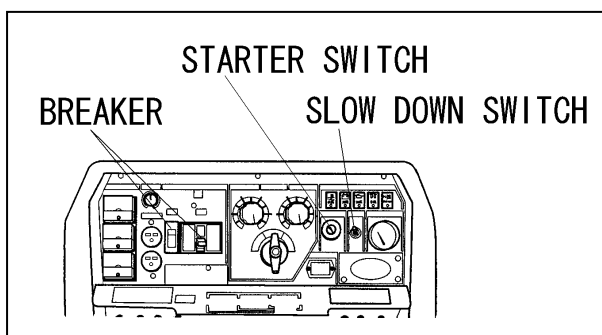

■ Restart after stopping due to fuel shortage

This equipment is incorporated in automatic vacuuming air feature. Therefore, even though the engine stops due to running out of fuel, you can restart the engine easily by the following steps.

Turn the starter switch to STOP.

Fill the fuel.

Turn the Slow-Down switch to ON.

Turn the starter switch to START and give the starter motor for about 10 seconds.

Release the starter switch, as promptly as the engine started.

Wait for about 1 minute to vacuum the air out. The engine speed becomes stable when the air is extracted.

<Caution>

- Never turn the engine NORMAL speed or connect the loads until the air is extracted completely (the engine speed becomes stable)

7-2 Stopping

Turn (Push-down) the breakers (1-P and 3-P) to OFF.

Turn the Slow-Down switch to ON.

Keep the engine idle (cooling down) for about 5 minutes.

Turn the starter switch to STOP.

After the engine has stopped, turn the fuel lever to CLOSE.

<Caution>

- When the engine does not stop in spite of turning the starter switch to STOP, turn the fuel lever to CLOSE, then the engine will stop in a few minutes. In this case, be sure to consult with our authorized distributor or our engineering section and ask to repair.

8. Welding Operation

8-1 Selection – Welding Cable

Select the cable with proper gauge, based on the allowable amperage and the length, per the table shown below.

The welding capacity is to reduce if the small gauge cable is used.

<Caution>

- Welding cables should be used unstrained. When the welding cables are used in swirl, the welding capacity is to reduce.

		Size of Cable (Unit: mm ²)					
Return Length Welding Current	20m	30m	40m	60m	80m	100m	
400A	38	50	60	100	125	200	
350A	30	50	60	80	125	150	
300A	30	38	50	80	100	125	
250A	22	30	38	60	80	100	
200A	22	30	30	50	60	80	
150A	22	22	22	38	50	60	
100A	22	22	22	30	30	38	

8-2 Polarity

There are two welding output terminals, 「+」 and 「-」.

Select the polarity according to the operation, referring to the table below.

<Caution>

- Follow the instruction of the welding rods, the polarity of which is specified.

	Application	Connection
Normal Polarity	Generals Welding, such as construction	Plus to the Earth (Material) Minus to holder (Rod)
Reverse Polarity	Thin Plate, Build-Up Welding, Stainless Steel	Plus to holder (Rod) Minus to the Earth (Material)

8-3 Connection – Welding Cable

Danger : Electric Shock

- Before connecting or disconnecting a welding cable from welding output terminals, stop the engine, and remove the engine key. A person performing should always keep the key.

Stop the engine.

Connect a welding cable to a crimping terminal, a welding rod holder, and a material holder.

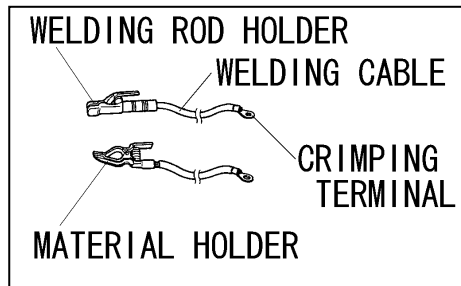

Connect the welding cables to the output terminals per the table below.

Eco (Single)	Single	Dual
Welding Rod φ2.0 – φ5.0	Welding Rod φ2.6 – φ8.0	Welding Rod φ2.0 – φ4.0
Welding Output Terminal A	Welding Output Terminal A	Welding Output Terminal A and Welding Output Terminal B

Close the output terminal cover, after finishing connections, and fix the cover with bolts.

<Caution>

- Be sure to crimp a crimping terminal to a cable and connect the cable to welding output terminal. Otherwise, welding output terminals may burn out by the heat caused by insufficient connections.
- Do not use a cable without a crimping terminal. If you use the cable, the insulation is peeled off partly, to bind to an output terminal, the output terminal may burn out by the heat caused by insufficient connections and also a bare part of the cable may touch the bonnet to short-circuit.

8-4 Duty Cycle

Duty cycle means the weldable time ratio for 10 minutes. This equipment is the rated duty cycle is 60%, namely, the weldable time is 6 minutes or less. Be sure to take 4 minutes recess after 6 minutes welding.

<Caution>

- The equipment may be damaged due to overheat, if welding more than 6 minutes successively or short time recess after the welding.

8-5 Welding

⚠ Caution : Suffocation from welding fume

- Be sure to wear a fume proof mask in operation, because welding fume contains poisonous gas and dust. Pay attention to the airflow direction and sufficient ventilation also in order to prevent from inhaling the fume.

⚠ Caution : Injuries to eyes and skin

- Be sure to wear spark protection glass(es)(Refer to the table below), long-sleeve shirts, gloves, etc. in order to protect eyes and skin from harmful spark in welding.

Standard for Spark Protection Glass (Japan Industrial Standard)

No.	7	8	9	10	11	12	13
Welding Current (A)	30-75		76-200			201-400	

⚠ Caution : Fire

- Keep any inflammable items and easily burning items away from the place in welding, because welding splashes spatters.

⚠ Caution : Burns

- Be sure to wear leather gloves, apron, shoe covers, eye protection glass(es)(mask), safety shoes, safety cap and long sleeve shirts, because welding splashes spatters.

<Caution>

- Never turn the output selector switch during welding, because it causes burnout of the switch.

2 persons can weld simultaneously.

Each person can adjust the welding current individually.

The current adjustable range by the current adjust dial, depends on the position each of the welding output selector switch.

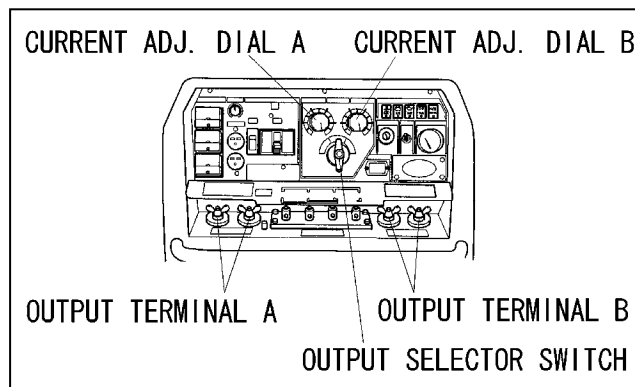

Set the selector switch, base on the application to use.

Adjust the current amperage by the current adjust dial, per the table below.

	Position	Freq	Welding Current at the dial position						
			MIN	1	2	3	4	5	MAX
1 Person	Eco		40	60	100	140	180	220	240
	Single Use	50Hz	90	120	190	250	320	360	380
		60Hz	110	140	200	260	320	380	400
2 Persons	Dual Use	50Hz	50	70	100	130	160	180	190
		60Hz	55	70	110	140	170	200	210

The values shown in the table are for reference only. The length and the ambient temperature affect the value.

When the remote control box is used, the values change to some degree.

9. Generator Operation

9-1 Output Range

- (1) 3-Phase 380-415V Output (3-Phase 4-Wire)
Maximum output from the terminals is 15KVA.

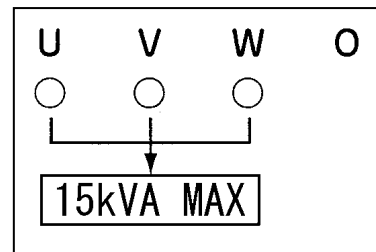

- (2) 1-Phase 380-415V Output Terminals

1-Phase 380-415V Output is available, using the output terminals. Maximum output available for the one set of the terminals is 9kVA but the total output for 3 sets is 12KVA, which please note and care. You should use the 3 sets wires evenly as much as possible.

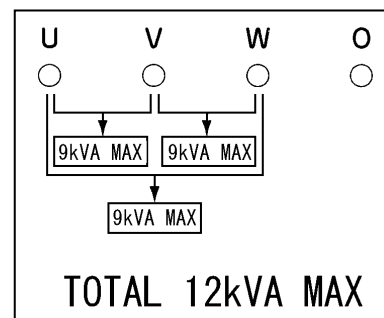

- (3) 1-Phase 220-240V Output Receptacles

1-Phase 220-240V Output is available through 2 receptacle sets.
Maximum output is 3kVA for 2 receptacle sets.

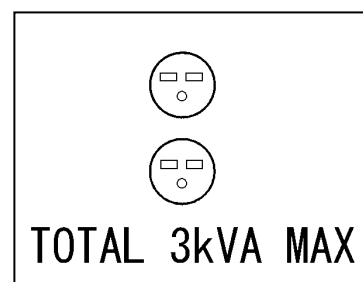

9-2 Output Limitation

Please refer to the following table, because electric tools and home appliances cannot be judged only by the rated output or the power consumption due to the efficiency and character of the components.

Applicable Load (For reference purpose only)

Loads	Capacity (kW)			
	1-Phase 220-240V	1-Phase 380-415V		3-Phase 380-415V
	Receptacle total	Terminal 1 set	Terminal 3 set pairs use	Terminal
Electric Bulb, Heater, etc.	3.0	9.0	12.0	-
Electric Tools, etc (Series Motor),	1.5	4.5	6.0	-
Mercury Bulb (High Power Factor Type)	1.2	3.6	4.8	-
Submersible Pump, Compressor, etc (Induction Motor)	1.2	3.6	4.8	6.0

Series Motor : Motor with brush

Induction Motor : Brushless Motor

The value described is 『OUTPUT』 for Induction Motor loads and 『POWER CONSUMPTION』 for the other equipment.

<Caution>

- Be sure to use the frequency designated in the equipment incorporated in mercury bulb or induction motor.
- The load incorporated in motor may require bigger power than the rated power consumption. Therefore, consult with our authorized distributor or our engineering section to clarify.
- When connecting to use 2 or more sets, start the load one by one, not to start them simultaneously.
- When switching a Mercury bulb ON again, wait for 15 minutes (about) until it cools down.

9-3 Operation

Danger : Electric Shock

- Before connecting or disconnecting a load cable from output terminals, always turn the circuit breakers (3-P and 1-P) to 「OFF」 position. And always stop engine, and remove the engine key. A person performing the maintenance should always keep the key.
- Ground the every grounding terminal to the earth as set out in the manual. If even one of all is unconnected by mistake or accident, it will be much more dangerous for human than the NO-RELAY case, because leaking current inevitably goes through the body. (Refer to 「5-4 Frequency Change」.)
- Even though all the current leakage relays in the loads have been grounded to the earth, the earth grounding terminal and the bonnet (canopy) should be grounded to the earth.
- Grounding should be made after the engine is stopped.
- Whenever the current leakage breaker activates, you should repair the leaking place first of all.

Caution : Injuries

- Be sure to connect to output terminals or insert a plug to a receptacle, after confirming that all the switches in the loads are positioned to 「OFF」.
- Be sure to select the correct frequency, designated in the loads. (Refer to 「5-4 Frequency Change」.)

Caution : Damage to the property • Aftermath

- Whenever connecting to use medical equipment or appliances, be sure to consult with the medical equipment company, doctor or hospital personnel.
- Be sure to select the correct frequency, designated in the loads. Otherwise, the loads may be damaged. (Refer to 「5-4 Frequency Change」.)

<Caution>

- The 3-Phase Volt meter reads 380-415V, apart from the circuit breakers (3-P and 1-P) positions to 「ON」 or 「OFF」, when the engine is driving.

After the engine starts (Refer to 『7-1 Starting』), operate the equipment as per the following procedures.

Turn the power switch OFF in the load, and then turn the circuit breaker to 『OFF』.

Check to confirm that the breakers (3-P and 1-P) position 『OFF』.

Connect the load to the output terminals or receptacles.

Close the output terminal cover, after finishing connections and screw up the bolts to fix the cover.

Turn the circuits breakers (3-P and 1-P) to 『ON』.

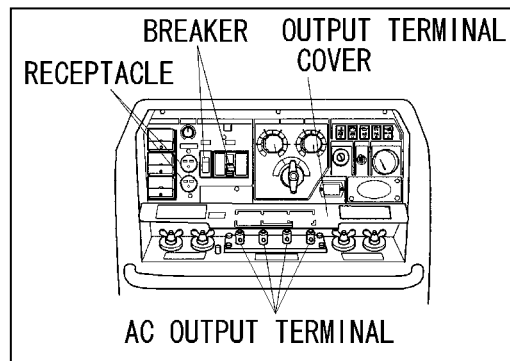

- The Circuit Breaker has activated due to overload

⚠ Caution: Injuries

- Be sure to turn the power switch 『OFF』 in the load when turning the circuit breaker to 『ON』 again, when the circuit breaker has activated.

When the electric supply exceeds the rated output (overload), the circuit breaker activates to trip off in order to shut down the circuit. When the load operation stops during operation, check the circuit breakers (3-P and 1-P).

In the case the 3-P breaker trips, the current leakage breaker lamp should have turned to OFF. If the lamp remains ON, refer to 『5-5 Earth Leakage Relay』.

When any breaker has tripped, restore the circuit breaker as per the following procedure.

Turn OFF all the power switches in the loads.

Turn (Push) down the circuit breakers (3-P and 1-P) to 『OFF』 once. And then turn (push) up the circuit breakers to 『ON』.

<Caution>

- Take care for overload, referring to 『9-2 Output Limitation』.
- When the output selector switch is positioned to Eco and AC power is used, the 3-P circuit breaker trips off to shut down the circuit. Stop using AC power and follow the above procedure to restore the circuit breaker.

10. Simultaneous Use of Welding and Generating

The circuit breakers (3-P and 1-P) react on the AC power supply circuit only. In the simultaneous use of welding and generating, there sometimes happens overload to the engine. Refer to the following table and limit the AC power use.

Limitation of AC Power Supply in the simultaneous use of welding and generating (60Hz)

Welding Output		AC Power Output	
Welding Rod / Amperage	Output Select	3-Phase 380-415V Output (P.F. 0.8)	1-Phase Output
φ2.0mm/60A	Dual	9.0kVA	10.5kVA
φ2.6mm/120A	Dual	8.5kVA	9.0kVA
φ3.2mm/140A	Dual	8.0kVA	8.5kVA
φ4.0mm/170A	Dual	7.5kVA	7.5kVA
φ5.0mm/240A	Single	2.5kVA	5.0kVA
φ6.0mm/300A	Single	2.0kVA	2.5kVA
φ8.0mm/380A	Single	0kVA	0kVA

- In order to secure stable AC output, the output selector switch should be positioned to DUAL in operation as long as possible.
- The 1-Phase output is the total of 1-Phase from the receptacle and 1-Phase from terminals.

<Caution>

- The simultaneous use of Eco welding and AC power is NOT available.
- Avoid the simultaneous use in the case high quality result in welding is required.

11. Checking and Maintenance

⚠ Danger : Electric Shock • Injuries

- Before performing any equipment check or maintenance, stop the engine, and remove engine key. A person performing the maintenance should always keep the key.

⚠ Caution: Fire • Burns

- Keep the equipment far away from fire.
- When checking engine, always stop the engine, and keep away from fire. Wait until the engine cools down, before performing any checks.

<Caution>

- The authorized technicians should perform all checking and maintenance work, except for the pre-startup checks.
- Request for the maintenance item with ● mark to the authorized distributor or our engineering section.
- Always use our genuine parts of replacement.

To optimize the use of this generator/welder, we recommend the periodical equipment checks and maintenance based on the following matrix.

Use the hour meter as a guide for the operating time.

Checking Items		Startup Check	Checking Time					Every 2000 hrs
			At 50hrs	Every 100 hrs.	Every 200 hrs	Every 400 hrs	Every 1000 hrs	
1	Check and Supply Fuel	○						
2	Check and Supply Engine Oil	○						
3	Engine Oil Change		1 st ○	2 nd or after ○				
4	Oil Filter Change		1 st ○		2 nd or after ○			
5	Check/Add Water/Coolant	○						
6	Water/Coolant Change							○ or one year
7	Clean Fuel Strainer		1 st ○	2 nd or after ○				
8	Change Fuel Filter					○		
9	Drain Water/Clean Fuel Tank				○			
10	Check Leakage Fuel, Oil, Water	○						
11	Check/Add Battery Water	○			○ Clean	○ change		
12	Clean Air Element		1 st ○	2 nd or after○				
13	Change Air Element					○		
14	Adjust Tension V-Belt		1 st ●	2 nd or after●				
15	Change V-Belt					● or 2 years		
16	Clean Radiator Fin					●		
17	Clean Radiator (inside)					●		
18	Change Fuel Hose, Oil Hose, Vibration-Absorbing Rubber							● or 2 years
19	Adjust Engine Valve Clearance						● Adjust	● Plane
20	Check/Adjust Injection Nozzle					●		
21	Check/Adjust Injection Pump							●

(1) Oil Change

First Time	50 hour mark
2 nd or after	Every 100 hours

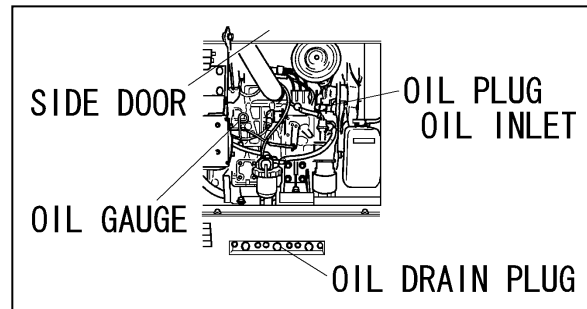

- 1 Remove the oil plug.
- 2 Loosen the oil drain plug and allow the oil to drain fully.
- 3 Reinstall the oil drain plug.
- 4 Checking the oil level by the oil level gauge, add oil into the oil filler to fill up to the max level (about 5.0 liter).
- 5 Reinstall the oil plug hand tight.

<Caution>

- Refer to 『6-1 Checking Engine Oil』 to select engine oil.
- Change the packing, whenever changing oil.
- Packing No. : 6C090-58961 (Kubota)

(2) Oil Filter Change

First Time	50 hour mark
2 nd or after	Every 200 hours

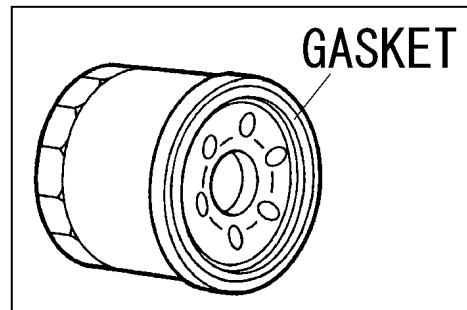
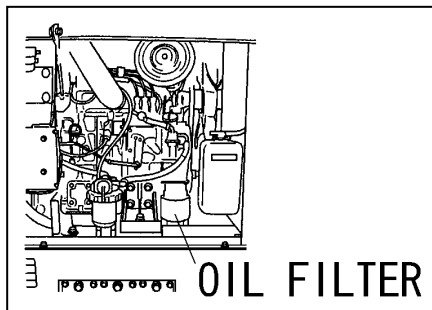

Drain the engine oil completely, as described in 『11-1 Oil Change』 .

Loosen and remove the oil filter, using an oil filter wrench.

Smear a little engine oil on the rubber gasket of a new filter.

Screw the new filter into place and tighten it by hand until the gasket contact the seat. Then, give it additional 『1.1/4 Turn』 to seat the filter, using an filter wrench.

Supply oil and install the filler cap.

<Caution>

- If an oil filter wrench is not available, contact our authorized distributor or our engineering section.
- Oil Filter Part No.: 16271-32092 (Kubota)

(3) Clean/Change Air Filter Element

Clean	1 st 50 hours and Every 100 hours afterwards
Replace	Every 400 hours

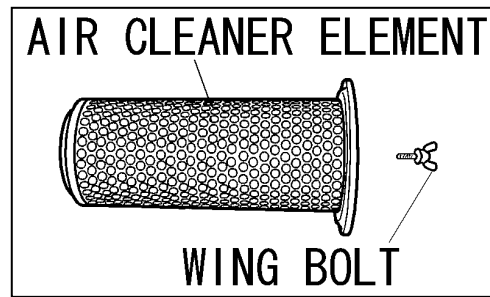
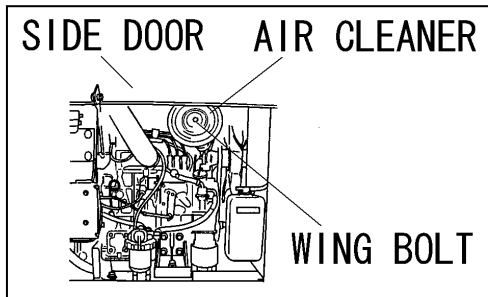

Loosen the wing bolts in the air cleaner and remove the air element.

Clean or replace the air element.

<The element is adhered with dried contaminants>

Blow up compressed air from inside the element.

<The element is adhered with carbon or oil>

Replace to a new one.

Reinstall it in reverse order.

<Caution>

- Clean more frequently, if it is used in dusty environment.
- Element Part No. 15471-11083 (Kubota)

(4) Clean/Change Fuel Strainer

Clean	1 st 50 hours and Every 100 hours afterwards
Replace	Every 400 hours

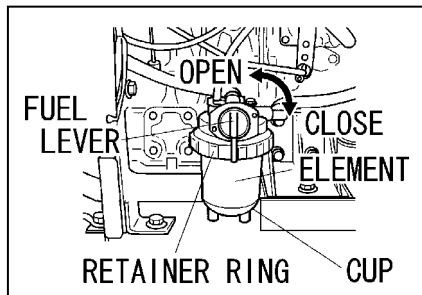

Turn the fuel lever to 『CLOSE』.

Unscrew the retainer ring counterclockwise, and remove the cup and the filter element.

Discard any dust or water inside the cup, and clean the filter element by blowing compressed air, or replace if necessary.

Reassemble it back.

<Caution>

- Be sure to check for any contaminants on the packing, whenever reinstalling the cup.
- Turn the fuel line valve lever 『OPEN』 after assembling, and check for any leak. Having confirmed no leak without fail, turn the fuel line valve 『CLOSE』.
- Element Part No.: 15521-43161 (Kubota)

(5) Drain Water from Fuel Tank

Drain Water	Every 200 hours
-------------	-----------------

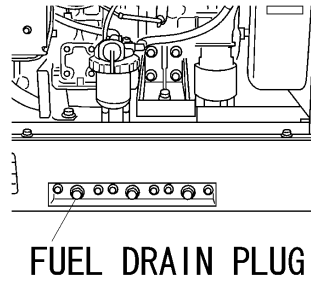

Unscrew the fuel drain plug.
Reinstall the drain plug, after draining water completely

<Caution>

- Change the packing, whenever changing oil.
- Packing Part No.: 6C090-58961 (Kubota)

(6) Changing Coolant/Water

Replace	Every 2 years or 2000 hours
---------	-----------------------------

(Total Coolant/Water Capacity: 4.3 liter, including sub tank cap. 0.6 liter.)

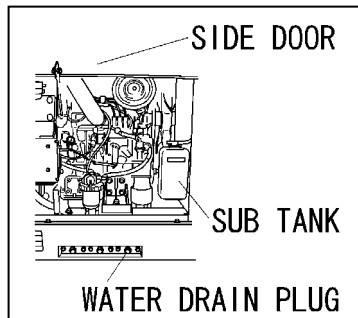
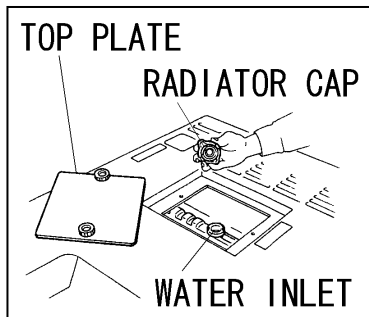

- 1 Remove the top plate.
- 2 Remove the radiator cap.
- 3 Loosen the water drain plug.
- 4 After draining all the water, reinstall the water drain plug.

<Caution>

- Change the packing, whenever changing oil.
 - Packing Part No.: 6C090-58961 (Kubota)
- 5 Replace all the water. In the sub tank.
 - 6 Fill the coolant/water to the MAX level (to the upper edge of the inlet).
 - 7 Reinstall the radiator cap.
 - 8 Install the top plate back.

12. Long-Term Storage

Danger : Electric Shock

- Before performing any equipment check or maintenance, stop the engine, and remove the engine key. A person performing the maintenance should always keep the key.

Caution : Injuries

- Before performing any equipment check or maintenance, stop the engine, and remove the engine key. A person performing the maintenance should always keep the key.

Caution : Fire • Burns

- When checking engine, always stop the engine, and keep far away from fire.
- Temperature around muffler and exhaust can get extremely high. Wait until the engine cools down, before performing any checks.

If the generator/welder will not be used for more than two months, perform the following maintenance and storage procedures.

Remove the battery.

Change the engine oil.

Drain fuel from the fuel tank and the fuel strainer.

Clean all parts, cover the generator/welder, and keep it in the storage, away from dust and humidity.

<Caution>

- Recharge the removed battery once a month.

13. Troubleshooting

Danger : Electric Shock

- Do not operate the equipment, if the equipment or you are wet.
- Before performing any equipment check or maintenance, stop the engine.

Caution : Injuries

- When performing equipment check and maintenance, always stop the engine.

Caution : Fire • Burns

- When checking engine, always stop the engine, and keep away from fire.
- Temperature around engine, muffler and exhaust can get extremely high. Wait until the engine cools down, before performing any checks.

Follow the guideline below, when performing any troubleshooting. If you cannot resolve the problems by this troubleshooting guide, contact the authorized distributor or our engineering section to request the repair.

Symptoms	Possible Cause	Corrective Actions
Starter motor does not start	<ol style="list-style-type: none"> 1. Weak Battery 2. Dead Battery 	<ol style="list-style-type: none"> 1. Recharge Battery 2. Replace Battery
Engine does not start	<ol style="list-style-type: none"> 1. Fuel lever to CLOSE 2. Insufficient Fuel 3. Water or contaminants in fuel 4. Fuse burnt 	<ol style="list-style-type: none"> 1. Fuel lever to OPEN 2. Replenish fuel 3. Drain water or clean fuel tank and fuel strainer 4. Repair
Engine starts, but stalls immediately	<ol style="list-style-type: none"> 1. Insufficient oil 2. High Water Temperature, Insufficient coolant/water 3. Unable to charge 	<ol style="list-style-type: none"> 1. Replenish oil 2. Replenish coolant/water 3. Repair
Welding Arc is weak	<ol style="list-style-type: none"> 1. Output selector switch positions to 『Eco』 or 『Dual』 2. Frequency Switch is to 『50Hz』 3. Wrong current adjustment dial position 4. Poor contact of cables 5. Improper Cable Diameter 6. Poor Contact to material 7. Dual Use 8. Engine output is down 9. Exceeding Duty Cycle (the warning lamp blinks) 	<ol style="list-style-type: none"> 1. Turn to 『SINGLE』 2. Turn to 『60Hz』 3. Turn the dial clockwise 4. Connect securely 5. Change cables according to 『Selection – Welding Cable』 6. Connect securely 7. Stop using AC Power 8. Keep 60% duty cycle 9. Wait until the equipment cools down (the lamp to OFF)
Excessive Welding Arc	<ol style="list-style-type: none"> 1. Output selector switch is to 『SINGLE』 2. Wrong current adjustment dial position 	<ol style="list-style-type: none"> 1. Turn to 『ECO』 or 『DUAL』 2. Turn the dial counterclockwise
No AC Output	<ol style="list-style-type: none"> 1. The breaker (3-P or 1-P) positions to 『OFF』 2. Output selector switch positions to 『ECO』 	<ol style="list-style-type: none"> 1. Turn to 『ON』 2. Turn to 『SINGLE』 or 『DUAL』
AC Output is Weak	<ol style="list-style-type: none"> 1. Wrong Frequency 2. The power consumption of the load exceeds the rated output 3. The rated current of the load exceeds the rated output 4. Dual Use 	<ol style="list-style-type: none"> 1. Change to the load frequency 2. Correspond the frequency of the lever to the bus bars 3. Adjust according to 『OUTPUT LIMITATION』 4. Stop welding
Slow-Down does not activate	<ol style="list-style-type: none"> 1. Welding cables short circuit 2. The power consumption of the load is 0.5A or below 	<ol style="list-style-type: none"> 1. Repair the short circuit 2. Turn the slow-down switch to 『OFF』
Engine does not stop	<ol style="list-style-type: none"> 1. Stop Solenoid disorder 	<ol style="list-style-type: none"> 1. Turn the fuel lever to 『CLOSE』 to stop and repair
Black and white smoke exhaust from muffler successively	<ol style="list-style-type: none"> 1. Overloaded use 	<ol style="list-style-type: none"> 1. Keep the duty cycle

14. Engine Wiring Diagram

ENGINE WIRING DIAGRAM

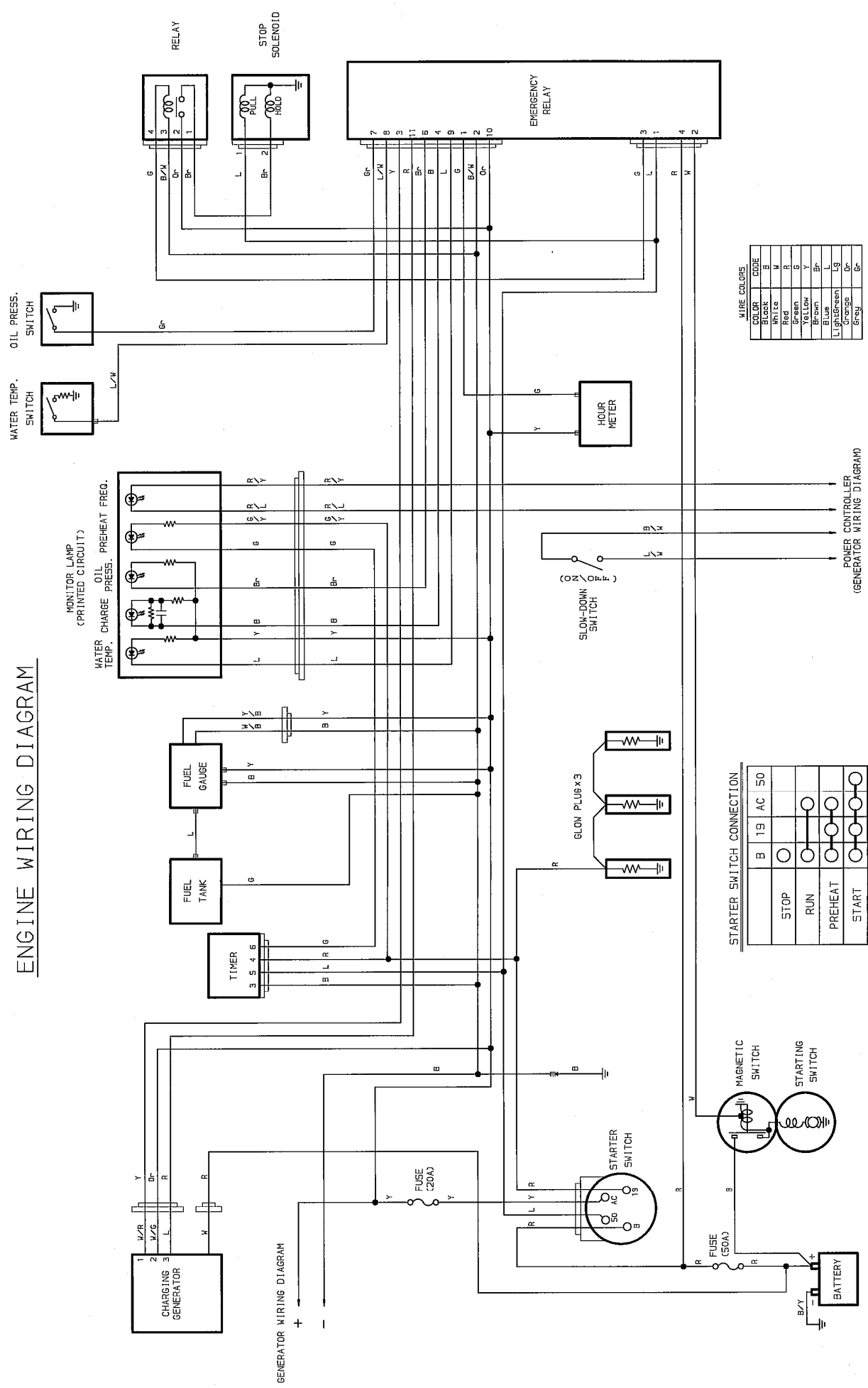

15. Generator Wiring Diagram

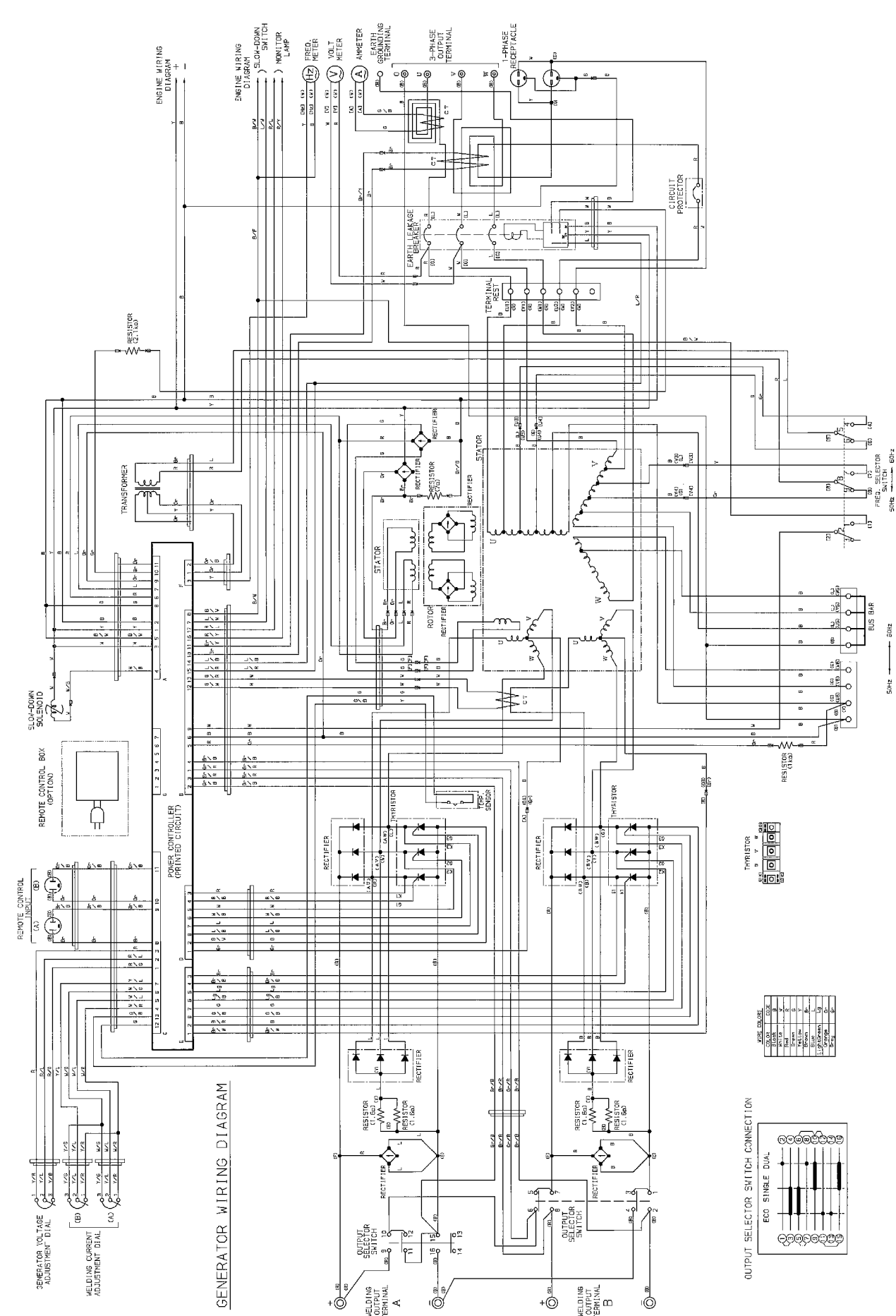

GENERATOR WIRING DIAGRAM

WIRE COLOR

RED	RED
BLACK	BLACK
GREEN	GREEN
YELLOW	YELLOW
BLUE	BLUE
WHITE	WHITE
GRAY	GRAY
BROWN	BROWN
PINK	PINK
ORANGE	ORANGE
PURPLE	PURPLE
TEAL	TEAL
SLATE	SLATE

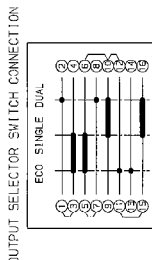

Shindaiwa Corporation

Head Office : 6 - 2 - 11 , Ozuka - Nishi ,
Asaminami - Ku , Hiroshima ,
731 - 3167 , Japan

Telephone: +81-82-849-2220 FAX: +81-82-849-2481

71905-94310

Free Manuals Download Website

<http://myh66.com>

<http://usermanuals.us>

<http://www.somanuals.com>

<http://www.4manuals.cc>

<http://www.manual-lib.com>

<http://www.404manual.com>

<http://www.luxmanual.com>

<http://aubethermostatmanual.com>

Golf course search by state

<http://golfingnear.com>

Email search by domain

<http://emailbydomain.com>

Auto manuals search

<http://auto.somanuals.com>

TV manuals search

<http://tv.somanuals.com>