

OVERVIEW

SiliconDrive combines all the high performance, high reliability, and multiyear lifecycle benefits of the standard SiliconDrive with a comprehensive suite of patented and patent-pending technologies that provide multiple security options to safeguard application data and software IP in embedded systems.

Applications requiring advanced levels of security such as data recorders, wearable and field computers, medical monitoring and diagnostic equipment, POS systems, and voting machines are able to activate security options to protect application data and software IP from theft, falling into the wrong hands from deployments in high-risk areas, corruption, and accidental or malicious overwrites.

PowerArmor prevents data corruption and loss from power disturbances by integrating patented technology into every SiliconDrive.

SiSMART acts as an early warning system to eliminate unscheduled downtime by constantly monitoring and reporting the exact amount of remaining storage system useful life.

SiSecure is a comprehensive suite of user-selectable security technologies that solves the critical need for robust storage security for embedded systems applications that have a small footprint and low-power requirement.

SiSECURE

| | |
|------------|---|
| PowerArmor | Eliminates drive corruption. |
| SiZone | Data zones with different security parameters. |
| SiKey | Ties SiliconDrive to a specific host and/or software IP. |
| SiProtect | Protection software for password-required, read/write, or read-only access. |
| SiSweep | Ultra-fast data erasure. |
| SiPurge | Non-recoverable data erasure. |

FEATURES

- RoHS 6 of 6 compliant
- Integrated PowerArmor, SiSMART, and SiSecure technologies
- Capacity range: 32MB to 16GB
- Supports both 8-bit and 16-bit data register transfers
- Supports 5V interface
- Data reliability <1 error in 10¹⁴ bits read
- MTBF >4,000,000 hours
- ATA-3 compliant
- Industry Hitachi 1.8" Drive form factor
- Supports PIO modes 0-4 and DMA modes 0-2



[Click here](#)



[Click here](#)

SILICONSYSTEMS PROPRIETARY

This document and the information contained within it is confidential and proprietary to SiliconSystems, Inc.
All unauthorized use and/or reproduction is prohibited.

26840 ALISO VIEJO PARKWAY, ALISO VIEJO, CA 92656 • PHONE: 949.900.9400 • FAX: 949.900.9500 • <http://www.siliconsystems.com>

DOCUMENT: 3650H-02DSR

JUNE 17, 2008

REVISION HISTORY

| Document No. | Release Date | Changes |
|----------------|------------------|---|
| 3650H-02DSR | June 17, 2008 | Updated: <ul style="list-style-type: none">• “Overview.”• “SiliconDrive Technology” to “SiSecure.” |
| 3650H-01DSR | May 25, 2008 | Updated: <ul style="list-style-type: none">• “Overview.”• <i>SiliconDrive Secure</i> to <i>SiSecure</i>.• SiProtect information. |
| SSDS00-3650H-R | November 8, 2007 | Initial release. |

SILICONSYSTEMS PROPRIETARY

This document and the information contained within it is confidential and proprietary to SiliconSystems, Inc.
All unauthorized use and/or reproduction is prohibited.

TABLE OF CONTENTS

| | |
|---|-----------|
| Overview | i |
| SiSecure | i |
| Features | i |
| Physical Specifications | 1 |
| Physical Dimensions | 1 |
| Pin Locations..... | 2 |
| Jumper Settings | 2 |
| Product Specifications | 3 |
| System Performance..... | 3 |
| System Power Requirements..... | 3 |
| System Reliability..... | 3 |
| Product Capacity Specifications..... | 4 |
| Environmental Specifications | 4 |
| Electrical Specification | 5 |
| Pin Assignments..... | 5 |
| Signal Descriptions..... | 6 |
| Absolute Maximum Ratings..... | 8 |
| Capacitance | 8 |
| DC Characteristics | 9 |
| AC Characteristics..... | 10 |
| I/O Access Read Timing..... | 10 |
| I/O Access Write Timing..... | 11 |
| True IDE Read/Write Access Timing..... | 12 |
| True IDE Multiword DMA Read/Write Access Timing | 13 |
| ATA and True IDE Register Decoding | 14 |
| Task File Register Specification | 14 |
| ATA Registers | 15 |
| Data Register | 15 |

SILICONSYSTEMS PROPRIETARY

This document and the information contained within it is confidential and proprietary to SiliconSystems, Inc.
All unauthorized use and/or reproduction is prohibited.

| | |
|--|-----------|
| Error Register | 15 |
| Feature Register..... | 16 |
| Sector Count Register | 17 |
| Sector Number Register..... | 18 |
| Cylinder Low Register | 19 |
| Cylinder High Register | 20 |
| Drive/Head Register | 21 |
| Status Register..... | 22 |
| Command Register | 23 |
| Alternate Status Register | 24 |
| Device Control Register | 25 |
| Device Address Register..... | 26 |
| ATA Command Block and Set Description | 27 |
| ATA Command Set | 27 |
| Check Power Mode — 98h, E5h..... | 29 |
| Executive Drive Diagnostic — 90h | 30 |
| Format Track — 50h | 31 |
| Identify Drive — ECh..... | 32 |
| <i>Identify Drive — Drive Attribute Data</i> | <i>33</i> |
| Idle — 97h, E3h..... | 35 |
| Idle Immediate — 95h, E1h..... | 36 |
| Initialize Drive Parameters — 91h..... | 37 |
| Recalibrate — 1Xh | 38 |
| Read Buffer — E4h | 39 |
| Read DMA — C8h..... | 40 |
| Read Multiple — C4h | 41 |
| Read Sector — 20h, 21h..... | 42 |
| Read Long Sector(s) — 22h, 23h..... | 43 |
| Read Verify Sector(s) — 40h, 41h | 44 |

SILICONSYSTEMS PROPRIETARY

This document and the information contained within it is confidential and proprietary to SiliconSystems, Inc.
All unauthorized use and/or reproduction is prohibited.

| | |
|---|-----------|
| Seek — 7Xh | 45 |
| Set Features — EFh..... | 46 |
| Set Multiple Mode — C6h | 47 |
| Set Sleep Mode — 99h, E6h..... | 48 |
| Standby — 96h, E2h | 49 |
| Standby Immediate — 94h, E0h | 50 |
| Write Buffer — E8h | 51 |
| Write DMA — CAh | 52 |
| Write Multiple — C5h | 53 |
| Write Sector(s) — 30h, 31h..... | 54 |
| Write Long Sector(s) — 32h, 33h..... | 55 |
| Erase Sector(s) — C0h | 56 |
| Request Sense — 03h | 57 |
| Translate Sector — 87h | 58 |
| Wear-Level — F5h | 59 |
| Write Multiple w/o Erase — CDh..... | 60 |
| Write Sector(s) w/o Erase — 38h..... | 61 |
| Write Verify — 3Ch..... | 62 |
| Sales and Support | 63 |
| Part Numbering..... | 63 |
| Nomenclature | 63 |
| Part Numbers | 64 |
| RoHS 6 of 6 Product Labeling — Pb-Free Identification Label | 64 |
| Sample Label | 65 |
| Related Documentation..... | 65 |

SILICONSYSTEMS PROPRIETARY

This document and the information contained within it is confidential and proprietary to SiliconSystems, Inc.
All unauthorized use and/or reproduction is prohibited.

SILICONSYSTEMS PROPRIETARY

This document and the information contained within it is confidential and proprietary to SiliconSystems, Inc.
All unauthorized use and/or reproduction is prohibited.

LIST OF FIGURES

| | |
|--|----|
| Figure 1: Physical Dimensions..... | 1 |
| Figure 2: Pin Locations | 2 |
| Figure 3: Jumper Settings..... | 2 |
| Figure 4: I/O Access Read Timing Diagram | 10 |
| Figure 5: I/O Access Write Timing Diagram..... | 11 |
| Figure 6: True IDE Read/Write Access Timing Diagram | 12 |
| Figure 7: True IDE Multiword DMA Read/Write Access Timing..... | 13 |
| Figure 8: Sample Label..... | 65 |

SILICONSYSTEMS PROPRIETARY

This document and the information contained within it is confidential and proprietary to SiliconSystems, Inc.
All unauthorized use and/or reproduction is prohibited.

SILICONSYSTEMS PROPRIETARY

This document and the information contained within it is confidential and proprietary to SiliconSystems, Inc.
All unauthorized use and/or reproduction is prohibited.

LIST OF TABLES

| | |
|--|----|
| Table 1: Physical Dimensions..... | 1 |
| Table 2: System Performance | 3 |
| Table 3: System Power Requirements | 3 |
| Table 4: System Reliability..... | 3 |
| Table 5: Product Capacity Specifications | 4 |
| Table 6: Environmental Specifications..... | 4 |
| Table 7: Pin Assignments | 5 |
| Table 8: Signal Descriptions | 6 |
| Table 9: Absolute Maximum Ratings | 8 |
| Table 10: Capacitance | 8 |
| Table 11: DC Characteristics | 9 |
| Table 12: I/O Access Read Timing | 10 |
| Table 13: I/O Access Write Timing | 11 |
| Table 14: True IDE Read/Write Access Timing | 12 |
| Table 15: True IDE Multiword DMA Read/Write Access Timing..... | 13 |
| Table 16: Task File Register Specification..... | 14 |
| Table 17: Error Register..... | 15 |
| Table 18: Feature Register | 16 |
| Table 19: Sector Count Register..... | 17 |
| Table 20: Sector Number Register | 18 |
| Table 21: Cylinder Low Register..... | 19 |
| Table 22: Cylinder High Register..... | 20 |
| Table 23: Drive/Head Register..... | 21 |
| Table 24: Status Register | 22 |
| Table 25: Command Register | 23 |
| Table 26: Alternate Status Register | 24 |
| Table 27: Device Control Register | 25 |

SILICONSYSTEMS PROPRIETARY

This document and the information contained within it is confidential and proprietary to SiliconSystems, Inc.
All unauthorized use and/or reproduction is prohibited.

| | |
|---|----|
| Table 28: Device Address Register | 26 |
| Table 29: ATA Command Block and Set Description | 27 |
| Table 30: ATA Command Set..... | 27 |
| Table 31: Check Power Mode — 98h, E5h..... | 29 |
| Table 32: Executive Drive Diagnostic — 90h..... | 30 |
| Table 33: Format Track — 50h | 31 |
| Table 34: Identify Drive — ECh | 32 |
| Table 35: Identify Drive — Drive Attribute Data | 33 |
| Table 36: Idle — 97h, E3h | 35 |
| Table 37: Idle Immediate — 95h, E1h | 36 |
| Table 38: Initialize Drive Parameters — 91h | 37 |
| Table 39: Recalibrate — 1Xh..... | 38 |
| Table 40: Read Buffer — E4h..... | 39 |
| Table 41: Read DMA — C8h | 40 |
| Table 42: Read Multiple — C4h..... | 41 |
| Table 43: Read Sector — 20h, 21h | 42 |
| Table 44: Read Long Sector(s) — 22h, 23h | 43 |
| Table 45: Read Verify Sector(s) — 40h, 41h..... | 44 |
| Table 46: Seek — 7Xh..... | 45 |
| Table 47: Set Features — EFh | 46 |
| Table 48: Set Features' Attributes | 46 |
| Table 49: Set Multiple Mode — C6h | 47 |
| Table 50: Set Sleep Mode — 99h, E6h | 48 |
| Table 51: Standby — 96h, E2h..... | 49 |
| Table 52: Standby Immediate — 94h, E0h | 50 |
| Table 53: Write Buffer — E8h | 51 |
| Table 54: Write DMA — CAh..... | 52 |
| Table 55: Write Multiple — C5h..... | 53 |
| Table 56: Write Sector(s) — 30h, 31h | 54 |

SILICONSYSTEMS PROPRIETARY

This document and the information contained within it is confidential and proprietary to SiliconSystems, Inc.
All unauthorized use and/or reproduction is prohibited.

| | |
|---|----|
| Table 57: Write Long Sector(s) — 32h, 33h | 55 |
| Table 58: Erase Sector(s) — C0h..... | 56 |
| Table 59: Request Sense — 03h..... | 57 |
| Table 60: Extended Error Codes | 57 |
| Table 61: Translate Sector — 87h..... | 58 |
| Table 62: Wear-Level — F5h..... | 59 |
| Table 63: Write Multiple w/o Erase — CDh | 60 |
| Table 64: Write Sector(s) w/o Erase — 38h | 61 |
| Table 65: Write Verify — 3Ch | 62 |
| Table 66: Part Numbering Nomenclature | 63 |
| Table 67: Part Numbers..... | 64 |
| Table 68: Related Documentation | 65 |

SILICONSYSTEMS PROPRIETARY

This document and the information contained within it is confidential and proprietary to SiliconSystems, Inc.
All unauthorized use and/or reproduction is prohibited.

SILICONSYSTEMS PROPRIETARY

This document and the information contained within it is confidential and proprietary to SiliconSystems, Inc.
All unauthorized use and/or reproduction is prohibited.

PHYSICAL SPECIFICATIONS

The SiliconDrive 1.8" Drive products are offered in an industry-standard 1.8" Drive form factor. See ["Part Numbering" on page 63](#) for details regarding 1.8" Drive capacities.

PHYSICAL DIMENSIONS

This section provides diagrams that describe the physical dimensions for the 1.8" Drive.

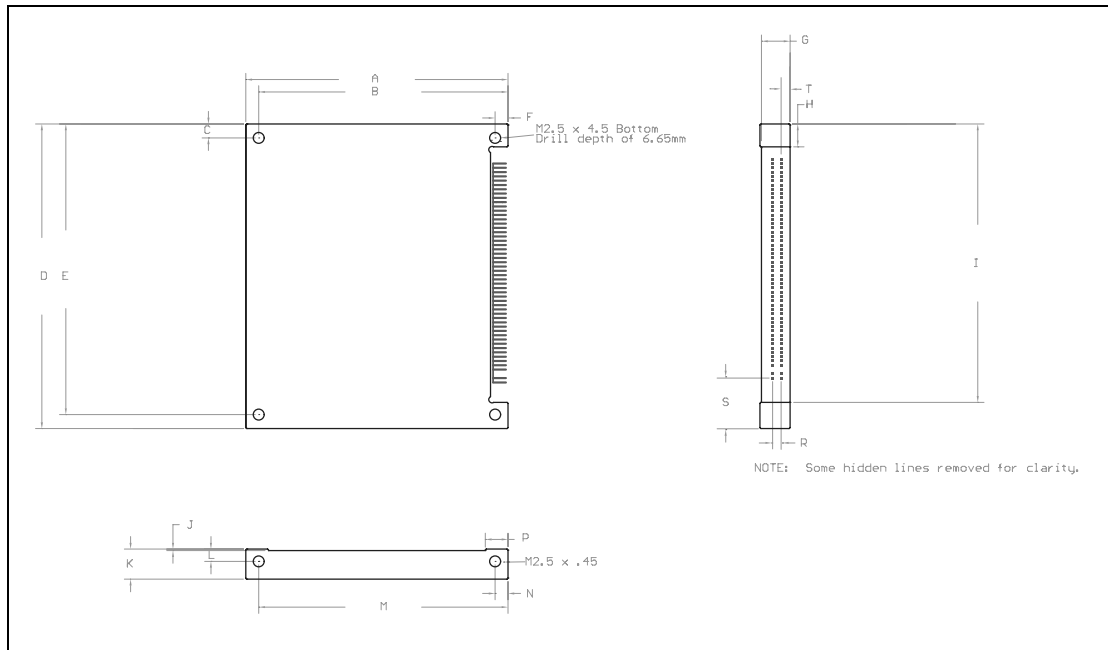

Figure 1: Physical Dimensions

Table 1: Physical Dimensions

| Dimension | Millimeters | Tolerance (mm) | Dimension | Millimeters | Tolerance (mm) |
|-----------|-------------|----------------|-----------|-------------|----------------|
| A | 60.00 | ±0.25 | K | 6.90 | ±0.125 |
| B | 57.05 | ±0.25 | L | 2.82 | ±.10 |
| C | 3.20 | ±0.10 | M | 57.05 | ±0.25 |
| D | 69.85 | ±0.25 | N | 2.95 | ±0.10 |
| E | 66.65 | ±0.25 | P | 5.19 | ±0.125 |
| F | 2.95 | ±0.10 | Q | 11.57 | ±0.125 |
| G | 6.55 | ±0.125 | R | 2.00 | ±0.10 |
| H | 5.25 | ±0.125 | S | 11.71 | ±0.125 |
| I | 63.85 | ±0.25 | T | 3.00 | ±0.10 |
| J | .35 | ±0.0125 | | | |

SILICONSYSTEMS PROPRIETARY

This document and the information contained within it is confidential and proprietary to SiliconSystems, Inc. All unauthorized use and/or reproduction is prohibited.

PIN LOCATIONS

The following diagram identifies the pin locations of the 1.8" Drive.

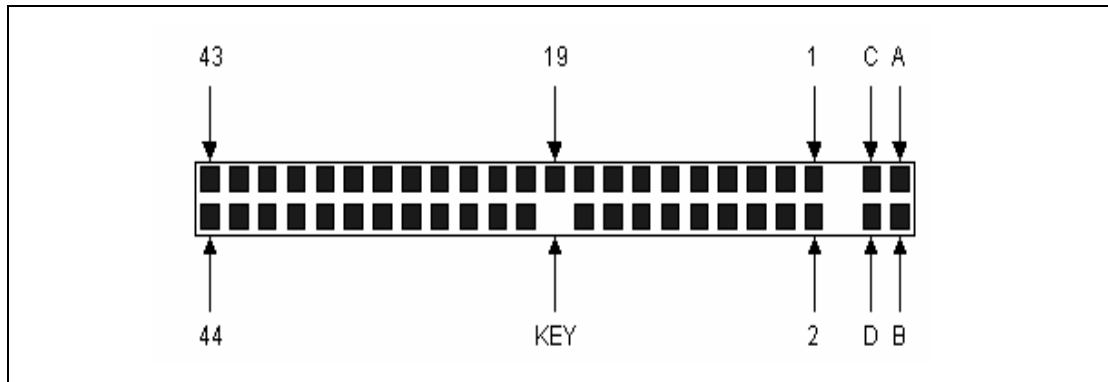

Figure 2: Pin Locations

JUMPER SETTINGS

The following diagram defines the SiliconDrive 1.8" Drive jumper settings.

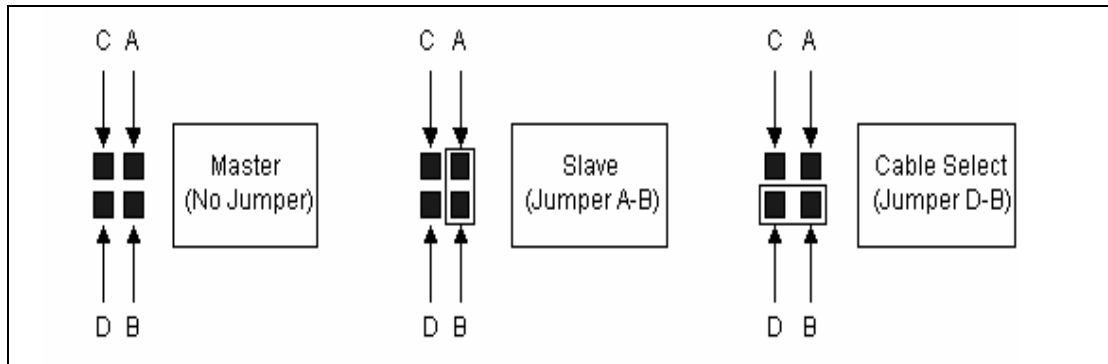

Figure 3: Jumper Settings

SILICONSYSTEMS PROPRIETARY

This document and the information contained within it is confidential and proprietary to SiliconSystems, Inc. All unauthorized use and/or reproduction is prohibited.

PRODUCT SPECIFICATIONS

Note: All SiliconDrive 1.8" Drive values quoted are typical at 25°C and nominal supply voltage.

SYSTEM PERFORMANCE

Table 2: System Performance

| | |
|---|---------------|
| Reset to Ready Startup Time (Typical/Maximum) | 200ms/400ms |
| Read Transfer Rate (Typical) | 8MBps |
| Write Transfer Rate (Typical) | 6MBps |
| Burst Transfer Rate | 16.7MBps |
| Controller Overhead (Command to DRQ) | 2ms (maximum) |

SYSTEM POWER REQUIREMENTS

Note: The 5V is the only operation for the 16GB capacity.

Table 3: System Power Requirements

| | |
|-------------------------|------------|
| DC Input Voltage | 5.0 ± 10% |
| Sleep (Standby Current) | >1.0mA |
| Read (Typical/Peak) | 30mA/100mA |
| Write (Typical/Peak) | 40mA/100mA |

SYSTEM RELIABILITY

Table 4: System Reliability

| | |
|------------------|--|
| MTBF (@ 25°C) | >4,000,000 hours |
| Data Reliability | <1 non-recoverable error in 10 ¹⁴ bits read |
| Endurance | >2,000,000 write/erase cycles |
| Data Retention | 10 years |

SILICONSYSTEMS PROPRIETARY

This document and the information contained within it is confidential and proprietary to SiliconSystems, Inc.
All unauthorized use and/or reproduction is prohibited.

PRODUCT CAPACITY SPECIFICATIONS

Table 5: Product Capacity Specifications

| Product Capacity | Formatted Capacity (Bytes) | Number of Sectors | Number of Cylinders | Number of Heads | Number of Sectors/Track |
|------------------|----------------------------|-------------------|---------------------|-----------------|-------------------------|
| 32MB | 32,702,464 | 63,872 | 499 | 2 | 32 |
| 64MB | 65,601,536 | 128,128 | 1001 | 4 | 32 |
| 128MB | 130,154,496 | 254,208 | 993 | 8 | 32 |
| 256MB | 260,571,136 | 508,928 | 994 | 16 | 32 |
| 512MB | 521,773,056 | 1,019,088 | 1011 | 16 | 63 |
| 1GB | 1,047,674,880 | 2,046,240 | 2030 | 16 | 63 |
| 2GB | 2,098,446,336 | 4,098,528 | 4066 | 16 | 63 |
| 4GB | 4,224,761,856 | 8,251,488 | 8186 | 16 | 63 |
| 8GB | 8,455,200,768 | 16,514,064 | 16,383* | 16 | 63 |
| 16GB | 16,494,428,160 | 32,215,680 | 16,383* | 16 | 63 |

* = All IDE drives 8GB and larger use 16383 cylinders, 16 heads, and 63 sectors/track due to interface restrictions.

ENVIRONMENTAL SPECIFICATIONS

Table 6: Environmental Specifications

| | |
|-------------|---|
| Temperature | 0°C to 70°C (Commercial) -40°C to 85°C (Industrial) |
| Humidity | 8% to 95% non-condensing |
| Vibration | 16.3gRMS, MIL-STD-810F, Method 514.5, Procedure I, Category 24 |
| Shock | 1000G, Half-sine, 0.5ms Duration 50g Pk, MIL-STD-810F, Method 516.5, Procedure I |
| Altitude | 80,000ft, MIL-STD-810F, Method 500.4, Procedure II |

SILICONSYSTEMS PROPRIETARY

This document and the information contained within it is confidential and proprietary to SiliconSystems, Inc.
All unauthorized use and/or reproduction is prohibited.

ELECTRICAL SPECIFICATION

PIN ASSIGNMENTS

The following table describes the SiliconDrive 1.8" Drive 44-pin IDE connector signals.

Table 7: Pin Assignments

| Pin | IDE-ATA | Pin | IDE-ATA |
|-----|-----------------|-----|-----------------|
| 1 | -RESET | 2 | GND |
| 3 | D7 | 4 | D8 |
| 5 | D6 | 6 | D9 |
| 7 | D5 | 8 | D10 |
| 9 | D4 | 10 | D11 |
| 11 | D3 | 12 | D12 |
| 13 | D2 | 14 | D13 |
| 15 | D1 | 16 | D14 |
| 17 | D0 | 18 | D15 |
| 19 | GND | 20 | KEY |
| 21 | DMARQ | 22 | GND |
| 23 | -IOWR | 24 | GND |
| 25 | -IORD | 26 | GND |
| 27 | IORDY | 28 | -CSEL |
| 29 | -DMACK | 30 | GND |
| 31 | INTRQ | 32 | -IOCS16 |
| 33 | A1 | 34 | -PDIAG |
| 35 | A0 | 36 | A2 |
| 37 | -CS0 | 38 | -CS1 |
| 39 | -DASP | 40 | GND |
| 41 | V _{CC} | 42 | V _{CC} |
| 43 | GND | 44 | NC |

SILICONSYSTEMS PROPRIETARY

This document and the information contained within it is confidential and proprietary to SiliconSystems, Inc.
All unauthorized use and/or reproduction is prohibited.

SIGNAL DESCRIPTIONS

Table 8: Signal Descriptions

| Signal Name | Pin(s) | Type | Description |
|-------------|--|------|---|
| A2-A0 | 36, 33, 35 | I | Address Inputs. These signals are asserted by the host to access the task registers in the device. |
| -CS0,-CS1 | 37, 38 | I | In the true IDE mode, -CS0 is the chip select for the task file registers while -CS1 is used to select the Alternate Status register and the Device Control register. |
| -CSEL | 28 | I | Cable Select. This internally pulled-up signal is used to configure this device as a master or a slave when the jumper configuration is in CSEL mode. When this pin is: <ul style="list-style-type: none"> • Grounded by the host, this device is configured as a master. • Open, this device is configured as a slave. |
| D15-D0 | 18, 16, 14, 12, 10, 8, 6, 4, 3, 5, 7, 9, 11, 13, 15, 17 | I/O | Data Inputs/Outputs. This is the 8-bit or 16-bit bidirectional interface between the host and device. The lower eight bits are used for 8-bit register transfers. |
| -DMACK | 29 | I | DMA Acknowledge. This signal is used by the host in response to DMARQ to initiate DMA transfers. The DMARQ/-DMACK handshake is used to provide flow control during the transfer. When -DMACK is asserted, -CS0 and -CS1 are not asserted and transfers are 16-bits wide. |
| DASP | 39 | I/O | Disk Active/Slave Present. This open drain output signal is asserted low any time the drive is active. In a master/slave configuration, this signal is used by the slave to inform the master that a slave is present. |

SILICONSYSTEMS PROPRIETARY

This document and the information contained within it is confidential and proprietary to SiliconSystems, Inc.
All unauthorized use and/or reproduction is prohibited.

Table 8: Signal Descriptions (Continued)

| Signal Name | Pin(s) | Type | Description |
|-------------|-------------------------------|------|--|
| DMARQ | 21 | O | DMA Request. This signal is used for DMA transfers between the host and device. DMARQ is asserted by the device when the device is ready to transfer data to/from the host. The direction of data transfer is controller by -IORD and -IOWR. This signal is used in a handshake manner with -DMACK (i.e., the device waits until the host asserts -DMACK before negating DMARQ, and reasserts DMARQ if there is more data to transfer). The DMARQ/-DMACK handshake is used to provide flow control during the transfer. |
| GND | 2, 19, 22, 24, 26, 30, 40, 43 | - | Ground. The device ground signal. |
| INTRQ | 31 | O | Interrupt Request. This signal is an active high interrupt request to the host. |
| IORDY | 27 | I | I/O Channel Ready. The signal is negated to extend the host transfer cycle of any host register access. |
| -IORD | 25 | I | Device I/O Read. This is the read strobe signal from the host. The falling edge of IORD enables data from the device onto the data bus. The rising edge of IORD latches data at the host. The host does not act on the data until it is latched. |
| -IOWR | 23 | I | Device I/O Write. This is the write strobe signal from the host. The rising edge of IOWR# latches data from the data bit signals. The device does not act on the data until it is latched. |
| KEY | 20 | - | Key. Reserved for the Connector Key. |
| -PDIAG | 34 | I/O | Pass Diagnostic. This open drain signal is asserted by the slave to indicate to the master that it has passed its diagnostics. |

SILICONSYSTEMS PROPRIETARY

This document and the information contained within it is confidential and proprietary to SiliconSystems, Inc.
All unauthorized use and/or reproduction is prohibited.

Table 8: Signal Descriptions (Continued)

| Signal Name | Pin(s) | Type | Description |
|-----------------|--------|------|--|
| -RESET | 1 | I | Device Reset. An active low signal. When active, this signal sets all internal registers to their default state. This signal is held asserted until at least 25 μ s after power has been stabilized during the device power-on. |
| V _{CC} | 41, 42 | - | Device Power Supply. The device power 5V signal. |

ABSOLUTE MAXIMUM RATINGS

Table 9: Absolute Maximum Ratings

| Symbol | Parameter | Minimum | Maximum | Units |
|------------------|-------------------------------------|---------|---------|-------|
| T _s | Storage Temperature | -55 | 125 | °C |
| T _A | Operating Temperature | -40 | 85 | °C |
| V _{CC} | V _{CC} with Respect to GND | -0.3 | 6.7 | V |
| V _{in} | Input Voltage | -0.5 | 6.0 | V |
| V _{out} | Output Voltage | -0.3 | 5.8 | V |

CAPACITANCE

Table 10: Capacitance

| Symbol | Parameter | Maximum | Units |
|------------------|---------------------------|---------|-------|
| C _{in} | Input Capacitance | 35 | pF |
| C _{out} | Output Capacitance | 35 | pF |
| CI/O | Bidirectional Capacitance | 35 | pF |

SILICONSYSTEMS PROPRIETARY

This document and the information contained within it is confidential and proprietary to SiliconSystems, Inc.
All unauthorized use and/or reproduction is prohibited.

DC CHARACTERISTICS

Table 11: DC Characteristics

| Symbol | Parameter | 5V \pm 10% | | Units |
|------------------|---------------------------------|-----------------------|-----------------------|---------|
| | | Minimum | Maximum | |
| V _{CC} | Power Supply Voltage | 4.5 | 5.5 | V |
| I _{LI} | Input Leakage *(1) Current | - | 5 | μ A |
| I _{LO} | Output Leakage *(1) Current | - | 5 | μ A |
| V _{CCR} | V _{CC} Read Current | - | 80 | mA |
| V _{CCW} | V _{CC} Write Current | - | 80 | mA |
| V _{CCS} | V _{CC} Standby Current | - | 0.5 | mA |
| V _{IL} | Input Low Voltage | -0.3 | 0.3 x V _{CC} | V |
| V _{IH} | Input High Voltage | 7 x V _{CC} | V _{CC} + 0.3 | V |
| V _{OL} | Output Low Voltage | - | 0.4 | V |
| V _{OH} | Output High Voltage | V _{CC} - 0.4 | - | V |

*(1) Except the pulled-up/pulled-down pin.

SILICONSYSTEMS PROPRIETARY

This document and the information contained within it is confidential and proprietary to SiliconSystems, Inc.
All unauthorized use and/or reproduction is prohibited.

AC CHARACTERISTICS

I/O Access Read Timing

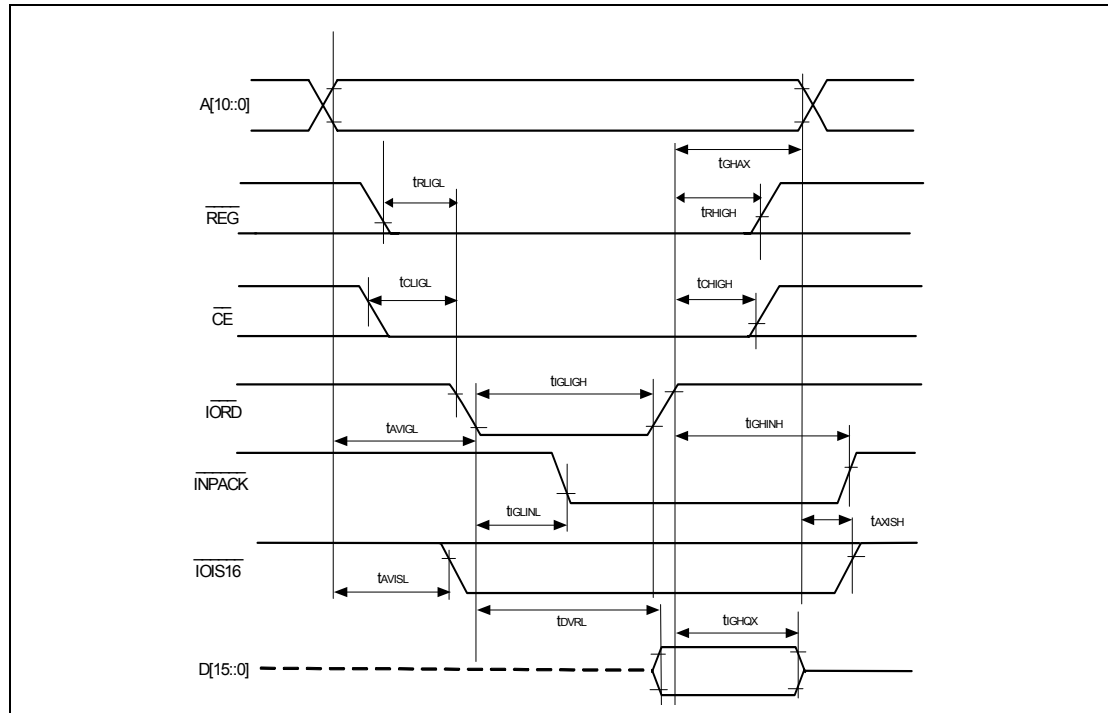

Figure 4: I/O Access Read Timing Diagram

Table 12: I/O Access Read Timing

| Symbol | Parameter | Minimum | Maximum | Units |
|-------------|-----------------------------------|---------|---------|-------|
| t_{DVRL} | Data Delay after IORD | - | 50 | ns |
| t_{GHQX} | Data Hold following IORD | 5 | - | ns |
| t_{GLIGH} | IORD Pulse Width | 65 | - | ns |
| t_{AVIGL} | Address Setup before IORD | 25 | - | ns |
| t_{GHAX} | Address Hold following IORD | 10 | - | ns |
| t_{CLIGL} | CE Setup before IORD | 5 | - | ns |
| t_{CHIGH} | CE Hold following IORD | 10 | - | ns |
| t_{RLIGL} | REG Setup before IORD | 5 | - | ns |
| t_{RHIGH} | REG Hold following IORD | 0 | - | ns |
| t_{GLINL} | INPACK Delay falling from IORD | - | (1) | ns |
| t_{GHINH} | INPACK Delay Rising from IORD | - | (1) | ns |
| t_{AVISL} | IOIS16 Delay Falling from Address | - | (1) | ns |
| t_{AXISH} | IOIS16 Delay Rising from Address | - | (1) | ns |

Note: (1) IOIS16 and INPACK are not supported.

SILICONSYSTEMS PROPRIETARY

This document and the information contained within it is confidential and proprietary to SiliconSystems, Inc.
All unauthorized use and/or reproduction is prohibited.

I/O Access Write Timing

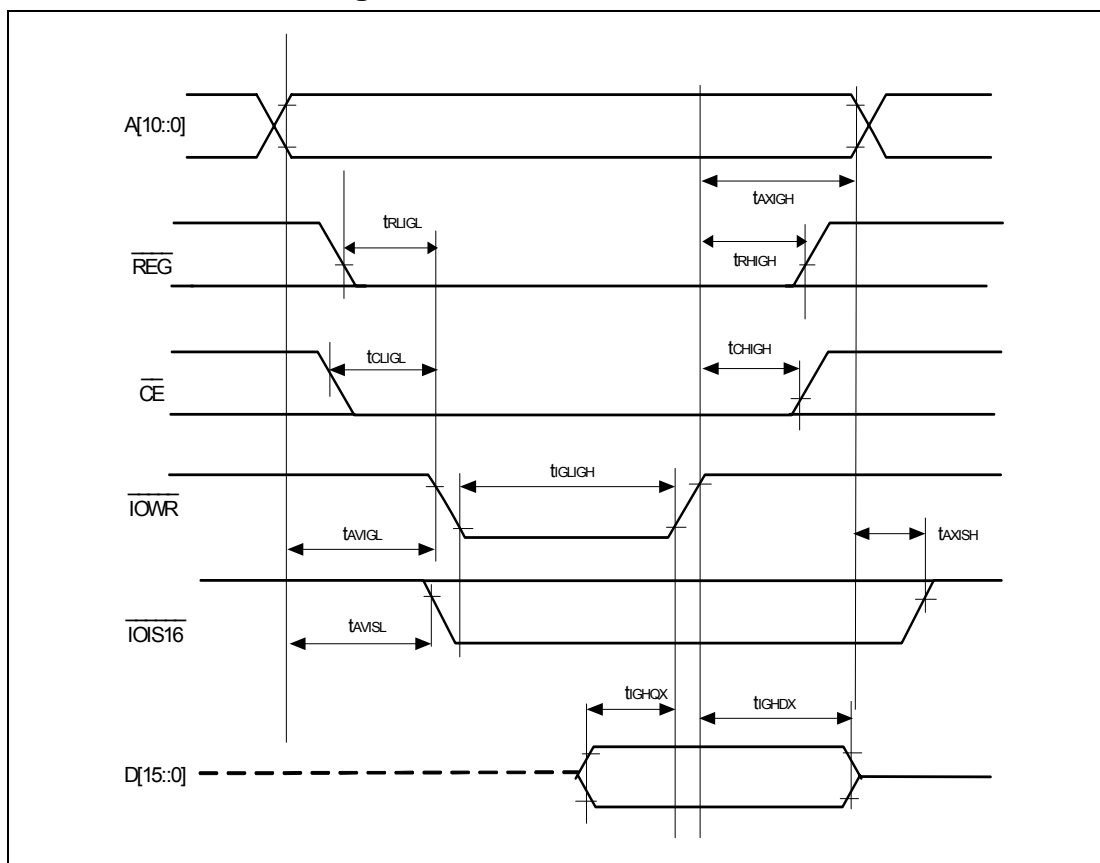

Figure 5: I/O Access Write Timing Diagram

Table 13: I/O Access Write Timing

| Symbol | Parameter | Minimum | Maximum | Units |
|--------------|-----------------------------------|---------|---------|-------|
| t_{IGHDX} | Data Hold following IOWR | 5 | - | ns |
| t_{IGHQX} | Data Setup before IOWR | 20 | - | ns |
| t_{IGLIGH} | IOWR Pulse Width | 65 | - | ns |
| t_{AVIGL} | Address Setup before IOWR | 25 | - | ns |
| t_{AXIGH} | Address Hold following IOWR | 10 | - | ns |
| t_{CLIGL} | CE Setup before IOWR | 5 | - | ns |
| t_{CHIGH} | CE Hold following IOWR | 10 | - | ns |
| t_{RLIGL} | REG Setup before IOWR | 5 | - | ns |
| t_{RHIGH} | REG Hold following IOWR | 0 | - | ns |
| t_{AVISL} | IOIS16 Delay Falling from Address | - | (1) | ns |
| t_{AXISH} | IOIS16 Delay Rising from Address | - | (1) | ns |

Note: (1) IOIS16 and INPACK are not supported.

SILICONSYSTEMS PROPRIETARY

This document and the information contained within it is confidential and proprietary to SiliconSystems, Inc.
All unauthorized use and/or reproduction is prohibited.

True IDE Read/Write Access Timing

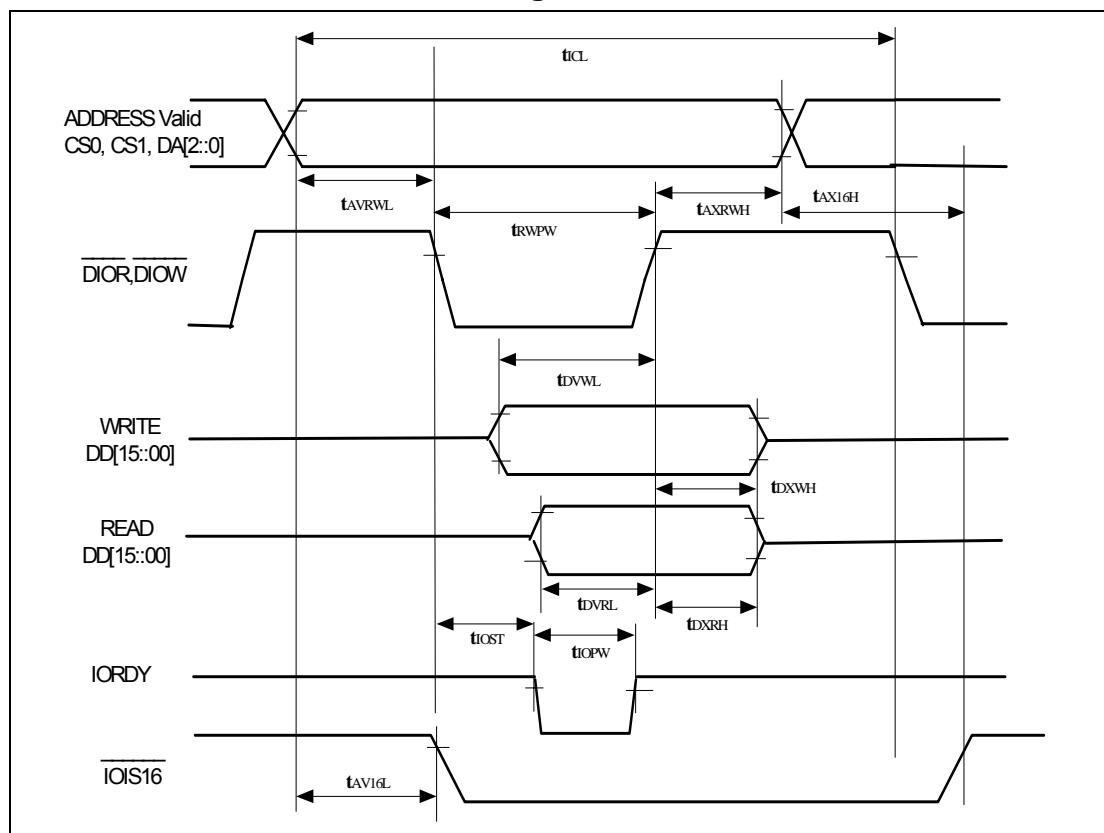

Figure 6: True IDE Read/Write Access Timing Diagram

Table 14: True IDE Read/Write Access Timing

| Symbol | Parameter | Minimum | Maximum | Units |
|-------------|--|---------|---------|-------|
| t_{ICL} | Cycle Time | 100 | - | ns |
| t_{AVRWL} | Address Valid to DIOR, DIOW Setup Time | 15 | - | ns |
| t_{RWPW} | DIOR, DIOW Pulse Width | 65 | - | ns |
| t_{DVWL} | DIOW Data Setup Time | 20 | - | ns |
| t_{DXWH} | DIOW Data Hold Time | 5 | - | ns |
| t_{DVRL} | DIOR Data Setup Time | 15 | - | ns |
| t_{DXRH} | DIOR Data Hold Time | 5 | - | ns |
| t_{AV16L} | Address Valid to IOCS16 Assertion | - | (1) | ns |
| t_{AX16H} | Address Valid to IOCS16 Negation | - | (1) | ns |
| t_{AXRWH} | DIOW, DIOR to Address Valid Hold Time | 10 | - | ns |
| t_{IOST} | IORDY Setup Time | - | (1) | ns |
| t_{IOPW} | IORDY Pulse Width | - | (1) | ns |

Note: (1) IOIS16 and INPACK are not supported.

SILICONSYSTEMS PROPRIETARY

This document and the information contained within it is confidential and proprietary to SiliconSystems, Inc.
All unauthorized use and/or reproduction is prohibited.

True IDE Multiword DMA Read/Write Access Timing

This function does not apply to SiliconDrives that have DMA disabled.

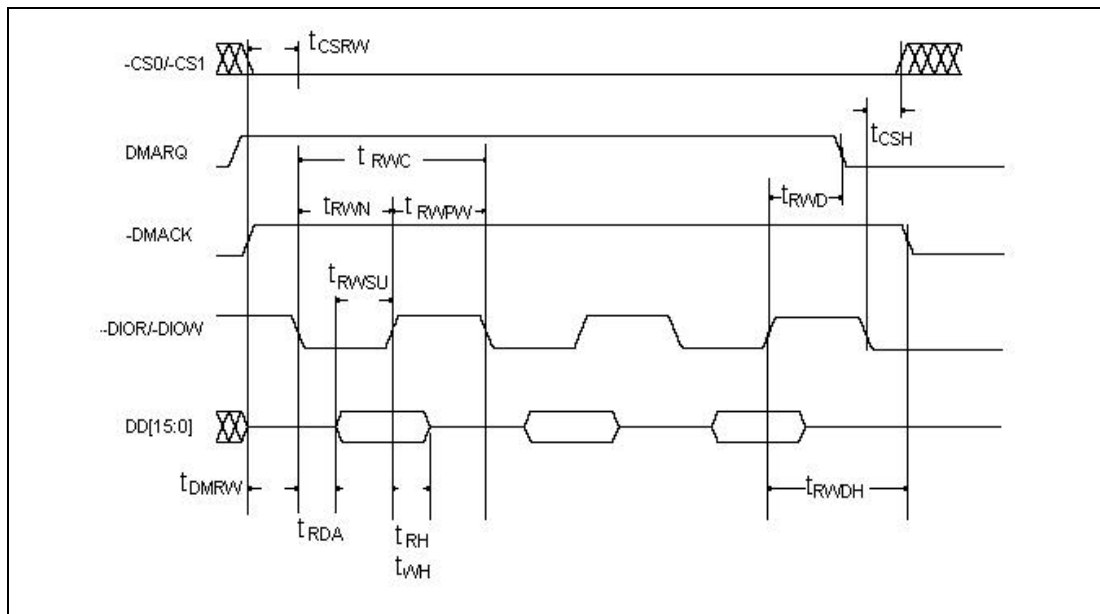

Figure 7: True IDE Multiword DMA Read/Write Access Timing

Table 15: True IDE Multiword DMA Read/Write Access Timing

| Symbol | Parameter | Minimum | Maximum | Units |
|------------|-------------------------------|---------|---------|-------|
| t_{RWC} | Cycle Time (mode 2) | 100 | - | ns |
| t_{RWPW} | DIOR/DIOW Pulse Width | 65 | - | ns |
| t_{RDA} | DIOR Data Access | - | 50 | ns |
| t_{RWSU} | DIOR/DIOW Data Setup Time | 15 | - | ns |
| t_{VH} | DIOW Data Hold Time | 5 | - | ns |
| t_{RH} | DIOR Data Hold Time | 5 | - | ns |
| t_{DMRW} | DMACK to DIOR/DIOW Setup Time | 0 | - | ns |
| t_{RWDH} | DIOR/DIOW to DMACK Hold Time | 5 | - | ns |
| t_{RWN} | DIOR/DIOW negated Pulse Width | 25 | - | ns |
| t_{RWD} | DIOR/DIOW to DMARQ Delay | - | 35 | ns |
| t_{CSRW} | CS(1:0) valid to DIOR/DIOW | 10 | - | ns |
| t_{CSH} | CS(1:0) Hold Time | 10 | - | ns |

SILICONSYSTEMS PROPRIETARY

This document and the information contained within it is confidential and proprietary to SiliconSystems, Inc.
All unauthorized use and/or reproduction is prohibited.

ATA AND TRUE IDE REGISTER DECODING

SiliconDrive can be configured as either a memory-mapped or an I/O devices. As noted earlier, communication to and from the drive is accomplished using the ATA Command Block.

TASK FILE REGISTER SPECIFICATION

The Task File registers are used for reading and writing the storage data in the SiliconDrive. The decoded addresses are as shown in the following table.

Table 16: Task File Register Specification

| CS0# | CS1# | DA02 | DA01 | DA00 | DIOR# = L | DIOW# = L |
|------|------|------|------|------|------------------|----------------|
| 0 | 1 | 0 | 0 | 0 | Data | Data |
| 0 | 1 | 0 | 0 | 1 | Error | Feature |
| 0 | 1 | 0 | 1 | 0 | Sector Count | Sector Count |
| 0 | 1 | 0 | 1 | 1 | Sector Number | Sector Number |
| 0 | 1 | 1 | 0 | 0 | Cylinder Low | Cylinder Low |
| 0 | 1 | 1 | 0 | 1 | Cylinder High | Cylinder High |
| 0 | 1 | 1 | 1 | 0 | Drive/Head | Drive/Head |
| 0 | 1 | 1 | 1 | 1 | Status | Command |
| 0 | 0 | X | X | X | Invalid | Invalid |
| 1 | 1 | X | X | X | High-Z | Not Used |
| 1 | 0 | 0 | X | X | High-Z | Not Used |
| 1 | 0 | 1 | 0 | X | High-Z | Not Used |
| 1 | 0 | 1 | 1 | 0 | Alternate Status | Device Control |
| 1 | 0 | 1 | 1 | 1 | Device Address | Not Used |

SILICONSYSTEMS PROPRIETARY

This document and the information contained within it is confidential and proprietary to SiliconSystems, Inc.
All unauthorized use and/or reproduction is prohibited.

ATA REGISTERS

DATA REGISTER

The Data register is a 16-bit register used to transfer data blocks between the host and drive buffers. The register may set to 8-bit mode by using the Set Features Command defined in "[Seek — 7Xh](#)" on page 45.

ERROR REGISTER

The Error register contains the error status, if any, generated from the last executed ATA command. The contents are qualified by the ERR bit being set in "[Status Register](#)" on page 22.

Table 17: Error Register

| Operation | D ₇ | D ₆ | D ₅ | D ₄ | D ₃ | D ₂ | D ₁ | D ₀ |
|---------------|----------------|----------------|----------------|----------------|----------------|----------------|----------------|----------------|
| Read | BBK | UNC | MC | IDNF | MCR | ABRT | TKNOF | AMNF |
| Default Value | 0 | 0 | 0 | 0 | 0 | 0 | 0 | 0 |

| Bit(s) | Description |
|--------|--|
| 7 | Bad Block Detected (BBK). Set when a bad block is detected. |
| 6 | Uncorrectable Data Error (UNC). Set when an uncorrectable error is encountered. |
| 5 | Media Changed (MC). Set to 0. |
| 4 | ID Not Found (IDNF). Set when the sector ID is not found. |
| 3 | MCR (Media Change Request). Set to 0. |
| 2 | Aborted Command (ABRT). Set when a command is aborted due to a drive error. |
| 1 | Track 0 Not Found (TKONF). Set when the executive drive diagnostic command is executed. |
| 0 | Address Mark Not Found (AMNF). Set in the case of a general error. |

SILICONSYSTEMS PROPRIETARY

This document and the information contained within it is confidential and proprietary to SiliconSystems, Inc.
All unauthorized use and/or reproduction is prohibited.

FEATURE REGISTER

The Feature register is command-specific and used to enable and disable interface features. This register supports only either odd or even byte data transfers.

Table 18: Feature Register

| Operation | D ₇ | D ₆ | D ₅ | D ₄ | D ₃ | D ₂ | D ₁ | D ₀ |
|------------|----------------|----------------|----------------|----------------|----------------|----------------|----------------|----------------|
| Read/Write | Feature Byte | | | | | | | |

SILICONSYSTEMS PROPRIETARY

This document and the information contained within it is confidential and proprietary to SiliconSystems, Inc.
All unauthorized use and/or reproduction is prohibited.

SECTOR COUNT REGISTER

The Sector Count register is used to read or write the sector count of the data for which an ATA transfer has been made.

Table 19: Sector Count Register

| Operation | D ₇ | D ₆ | D ₅ | D ₄ | D ₃ | D ₂ | D ₁ | D ₀ |
|---------------|----------------|----------------|----------------|----------------|----------------|----------------|----------------|----------------|
| Read/Write | Sector Count | | | | | | | |
| Default Value | 0 | 0 | 0 | 0 | 0 | 0 | 0 | 1 |

SILICONSYSTEMS PROPRIETARY

This document and the information contained within it is confidential and proprietary to SiliconSystems, Inc.
All unauthorized use and/or reproduction is prohibited.

SECTOR NUMBER REGISTER

The Sector Number register is set by the host to specify the starting sector number associated with the next ATA command to be executed. Following a qualified ATA command sequence, the device sets the register value to the last sector read or written as a result of the previous AT command.

When Logical Block Addressing (LBA) mode is implemented and the host issues a command, the contents of the register describe the Logical Block Number bits A[7:0]. Following an ATA command, the device loads the register with the LBA block number resulting from the last ATA command.

Table 20: Sector Number Register

| Operation | D ₇ | D ₆ | D ₅ | D ₄ | D ₃ | D ₂ | D ₁ | D ₀ |
|---------------|--|----------------|----------------|----------------|----------------|----------------|----------------|----------------|
| Read/Write | Sector Number (CHS Addressing) | | | | | | | |
| | Logical Block Number bits A07-A00 (LBA Addressing) | | | | | | | |
| Default Value | 0 | 0 | 0 | 0 | 0 | 0 | 0 | 1 |

SILICONSYSTEMS PROPRIETARY

This document and the information contained within it is confidential and proprietary to SiliconSystems, Inc.
All unauthorized use and/or reproduction is prohibited.

CYLINDER LOW REGISTER

The Cylinder Low register is set by the host to specify the cylinder number low byte. Following an ATA command, the content of the register is written by the device, identifying the cylinder number low byte.

In LBA mode, the 8-bit register maintains the contents of the Logical Block number address bits A15:A08.

Table 21: Cylinder Low Register

| Operation | D ₇ | D ₆ | D ₅ | D ₄ | D ₃ | D ₂ | D ₁ | D ₀ |
|---------------|--|----------------|----------------|----------------|----------------|----------------|----------------|----------------|
| Read/Write | Cylinder Number Low Byte (CHS Addressing) | | | | | | | |
| | Logical Block Number bits A15-A08 (LBA Addressing) | | | | | | | |
| Default Value | 0 | 0 | 0 | 0 | 0 | 0 | 0 | 0 |

SILICONSYSTEMS PROPRIETARY

This document and the information contained within it is confidential and proprietary to SiliconSystems, Inc.
All unauthorized use and/or reproduction is prohibited.

CYLINDER HIGH REGISTER

The Cylinder High register is set by the host to specify the cylinder number high byte. Following an ATA command, the content of the register is set internally by the device, identifying the cylinder number high byte.

In LBA mode, the 8-bit register maintains the contents of the Logical Block number address bits A23:A16.

Table 22: Cylinder High Register

| Operation | D ₇ | D ₆ | D ₅ | D ₄ | D ₃ | D ₂ | D ₁ | D ₀ |
|---------------|--|----------------|----------------|----------------|----------------|----------------|----------------|----------------|
| Read/Write | Cylinder Number Low Byte (CHS Addressing) | | | | | | | |
| | Logical Block Number bits A23-A16 (LBA Addressing) | | | | | | | |
| Default Value | 0 | 0 | 0 | 0 | 0 | 0 | 0 | 0 |

SILICONSYSTEMS PROPRIETARY

This document and the information contained within it is confidential and proprietary to SiliconSystems, Inc.
All unauthorized use and/or reproduction is prohibited.

DRIVE/HEAD REGISTER

The Drive/Head register is used by the host and the device to select the type of addressing (CHS or LBA), the drive letter, and either bits 3-0 of the head number in CHS mode or logical block number bits 27-24 in LBA mode.

Table 23: Drive/Head Register

| Operation | D ₇ | D ₆ | D ₅ | D ₄ | D ₃ | D ₂ | D ₁ | D ₀ |
|---------------|----------------|----------------|----------------|----------------|----------------|----------------|----------------|----------------|
| Read/Write | 1 | LBA | 1 | DRV | HS3 LBA27 | HS2 LBA26 | HS1 LBA25 | HS0 LBA24 |
| Default Value | 1 | 0 | 1 | 0 | 0 | 0 | 0 | 0 |

The Drive/Head register is used by the host to specify one of a pair of ATA drives present in the platform.

| Bit(s) | Description |
|--------|--|
| 6 | LBA. Selects between CHS (0) and LBA (1) addressing mode. |
| 4 | Drive Address (DRV). Indicates the drive number selected by the host, either 0 or 1. |
| 3-0 | <p>HS3 to 0. Indicates bits 3-0 of the head number in CHS addressing mode or LBA bits 27-24 in LBA mode.</p> <ul style="list-style-type: none"> • CHS to LBA conversion: $LBA = (C \times HpC + H) \times SpH + S - 1$ • LBA to CHS conversion: <ul style="list-style-type: none"> ◦ $C = LBA / (HpC \times SpH)$ ◦ $H = (LBA / SpH) \bmod (HpC)$ ◦ $S = (LBA \bmod (SpH)) + 1$ <p>...where:</p> <ul style="list-style-type: none"> ◦ C is the cylinder number ◦ H is the head number ◦ S is the sector count ◦ HpC is the head count per cylinder count ◦ SpH is the sector count per head count (track) |

SILICONSYSTEMS PROPRIETARY

This document and the information contained within it is confidential and proprietary to SiliconSystems, Inc.
All unauthorized use and/or reproduction is prohibited.

STATUS REGISTER

The Status register provides the device's current status to the host. The status register is an 8-bit read-only register. When the contents of the register are read by the host, the IREQ# bit is cleared.

Table 24: Status Register

| Operation | D ₇ | D ₆ | D ₅ | D ₄ | D ₃ | D ₂ | D ₁ | D ₀ |
|---------------|----------------|----------------|----------------|----------------|----------------|----------------|----------------|----------------|
| Read/Write | BSY | DRDY | DWF | DSC | DRQ | CORR | IDX | ERR |
| Default Value | 0 | 0 | 0 | 0 | 0 | 0 | 0 | 0 |

| Bit(s) | Description |
|--------|--|
| 7 | Busy (BSY). Set when the drive is busy and unable to process any new ATA commands. |
| 6 | Data Ready (DRDY). Set when the device is ready to accept ATA commands from the host. |
| 5 | Drive Write Fault (DWF). Always set to 0. |
| 4 | Drive Seek Complete (DSC). Set when the drive heads have been positioned over a specific track. |
| 3 | Data Request (DRQ). Set when a device is ready to transfer a word or byte of data to or from the host and the device. |
| 2 | Corrected Data (CORR). Always set to 0. |
| 1 | Index (IDX). Always set to 0. |
| 0 | Error (ERR). Set when an error occurs during the previous ATA command. |

SILICONSYSTEMS PROPRIETARY

This document and the information contained within it is confidential and proprietary to SiliconSystems, Inc.
All unauthorized use and/or reproduction is prohibited.

COMMAND REGISTER

The Command register specifies the ATA command code being issued to the drive by the host. Execution of the command begins immediately following the issuance of the command register code by the host.

Table 25: Command Register

| Operation | D ₇ | D ₆ | D ₅ | D ₄ | D ₃ | D ₂ | D ₁ | D ₀ |
|------------|------------------|----------------|----------------|----------------|----------------|----------------|----------------|----------------|
| Read/Write | ATA Command Code | | | | | | | |

See ["ATA Command Block and Set Description" on page 27](#) for a listing of the supported ATA commands.

SILICONSYSTEMS PROPRIETARY

This document and the information contained within it is confidential and proprietary to SiliconSystems, Inc.
All unauthorized use and/or reproduction is prohibited.

ALTERNATE STATUS REGISTER

The Alternate Status register is a read-only register indicating the status of the device, following the previous ATA command. See ["Status Register" on page 22](#) for specific details.

Table 26: Alternate Status Register

| Operation | D ₇ | D ₆ | D ₅ | D ₄ | D ₃ | D ₂ | D ₁ | D ₀ |
|---------------|----------------|----------------|----------------|----------------|----------------|----------------|----------------|----------------|
| Read/Write | BSY | DRDY | DWF | DSC | DRQ | CORR | IDX | ERR |
| Default Value | 0 | 0 | 0 | 0 | 0 | 0 | 0 | 0 |

SILICONSYSTEMS PROPRIETARY

This document and the information contained within it is confidential and proprietary to SiliconSystems, Inc.
All unauthorized use and/or reproduction is prohibited.

DEVICE CONTROL REGISTER

The Device Control register is used to control the interrupt request and issue ATA software resets.

Table 27: Device Control Register

| Operation | D ₇ | D ₆ | D ₅ | D ₄ | D ₃ | D ₂ | D ₁ | D ₀ |
|-----------|----------------|----------------|----------------|----------------|----------------|----------------|----------------|----------------|
| Write | - | - | - | - | 1 | SRST | nIEN | 0 |

| Bit(s) | Description |
|--------|--|
| 7-4 | Reserved bits. |
| 3 | Always set to 1. |
| 2 | Software Reset (SRST) . When set, resets the ATA software. |
| 1 | Interrupt Enable (nIEN) . When set, device interrupts are disabled. There is no function in the memory-mapped mode. |
| 0 | Always set to 0. |

SILICONSYSTEMS PROPRIETARY

This document and the information contained within it is confidential and proprietary to SiliconSystems, Inc.
All unauthorized use and/or reproduction is prohibited.

DEVICE ADDRESS REGISTER

The Device Address register is used to maintain compatibility with ATA disk drive interfaces.

Table 28: Device Address Register

| Operation | D ₇ | D ₆ | D ₅ | D ₄ | D ₃ | D ₂ | D ₁ | D ₀ |
|---------------|----------------|----------------|----------------|----------------|----------------|----------------|----------------|----------------|
| Read/Write | - | nWTG | nHS3 | nHS2 | nHS1 | nHS0 | nDS1 | nDS0 |
| Default Value | 0 | 0 | 1 | 1 | 1 | 1 | 1 | 0 |

| Bit(s) | Description |
|--------|--|
| 7 | Reserved bit. |
| 6 | Write Gate (nWTG) . Low when a write to the device is in process. |
| 5-2 | nHS3 to nHS0 . The negated binary address of the currently selected head. |
| 1 | nDS1 . Low when drive 1 is selected and active. |
| 0 | nDS0 . Low when drive 0 is selected and active. |

SILICONSYSTEMS PROPRIETARY

This document and the information contained within it is confidential and proprietary to SiliconSystems, Inc.
All unauthorized use and/or reproduction is prohibited.

ATA COMMAND BLOCK AND SET DESCRIPTION

In accordance with the *ANSI ATA Specification*, the device implements seven registers that are used to transfer instructions to the device by the host. These commands follow the ANSI standard ATA protocol. A description of the ATA command block is provided in the following table.

Table 29: ATA Command Block and Set Description

| Operation | D ₇ | D ₆ | D ₅ | D ₄ | D ₃ | D ₂ | D ₁ | D ₀ |
|---------------|----------------|----------------|----------------|----------------|----------------|----------------|----------------|----------------|
| Feature | | | | | X | | | |
| Sector Count | | | | | X | | | |
| Sector Number | | | | | X | | | |
| Cylinder Low | | | | | X | | | |
| Cylinder High | | | | | X | | | |
| Drive Head | 1 | LBA | 1 | Drive | | | X | |
| Command | | | | | X | | | |

ATA COMMAND SET

Table 30: ATA Command Set

| Class | Command Name | Command Code | Registers Used | | | | | |
|-------|-----------------------------|--------------|----------------|----|----|----|----|-----|
| | | | FR | SC | SN | CY | DH | LBA |
| 1 | Check Power Mode | 98h, E5h | - | - | - | - | D | - |
| 1 | Execute Drive Diagnostics | 90h | - | - | - | - | D | - |
| 1 | Erase Sector | C0h | - | Y | Y | Y | Y | Y |
| 2 | Format Track | 50h | - | Y | - | Y | Y | Y |
| 1 | Identify Drive | ECh | - | - | - | - | D | - |
| 1 | Idle | 97h, E3h | - | Y | - | - | D | - |
| 1 | Idle Immediate | 95h, E1h | - | | - | - | D | - |
| 1 | Initialize Drive Parameters | 91h | - | Y | - | - | Y | - |
| 1 | Read Buffer | E4h | - | - | - | - | D | - |
| 1 | Read DMA* | C8h | - | Y | Y | Y | Y | Y |
| 1 | Read Multiple | C4h | - | Y | Y | Y | Y | Y |

SILICONSYSTEMS PROPRIETARY

This document and the information contained within it is confidential and proprietary to SiliconSystems, Inc. All unauthorized use and/or reproduction is prohibited.

Table 30: ATA Command Set (Continued)

| Class | Command Name | Command Code | Registers Used | | | | | |
|-------|---------------------------|--------------|----------------|----|----|----|----|-----|
| | | | FR | SC | SN | CY | DH | LBA |
| 1 | Read Long Sector | 22h, 23h | - | - | Y | Y | Y | Y |
| 1 | Read Sector(s) | 20h, 21h | - | - | Y | Y | Y | Y |
| 1 | Read Verify Sector(s) | 40h, 41h | - | Y | Y | Y | Y | Y |
| 1 | Recalibrate | 1Xh | - | - | - | - | Y | - |
| 1 | Request Sense | 03h | - | - | - | - | D | - |
| 1 | Seek | 7Xh | - | - | Y | Y | Y | Y |
| 1 | Set Features | EFh | Y | - | - | - | D | - |
| 1 | Set Multiple Mode | C6h | - | Y | - | - | D | - |
| 1 | Set Sleep Mode | 99h, E6h | - | - | - | - | D | - |
| 1 | Standby | 96h, E2h | - | - | - | - | D | - |
| 1 | Standby Immediate | 94h, E0h | - | - | - | - | D | - |
| 1 | Translate Sector | 87h | - | Y | Y | Y | Y | Y |
| 1 | Wear Level | F5h | - | - | - | - | Y | - |
| 2 | Write Buffer | E8h | - | - | - | - | D | - |
| 1 | Write DMA* | CAh | - | Y | Y | Y | Y | Y |
| 2 | Write Long Sector | 32h, 33h | - | - | Y | Y | Y | Y |
| 3 | Write Multiple | C5h | - | Y | Y | Y | Y | Y |
| 3 | Write Multiple w/o Erase | CDh | - | Y | Y | Y | Y | Y |
| 2 | Write Sector(s) | 30h, 31h | - | Y | Y | Y | Y | Y |
| 2 | Write Sector(s) w/o Erase | 38h | - | Y | Y | Y | Y | Y |
| 3 | Write Verify | 3Ch | - | Y | Y | Y | Y | Y |

* = This function does not apply to SiliconDrives that have DMA disabled.

Notes:

- CY = Cylinder
- SC = Sector Count
- DH = Drive/Head
- SN = Sector Number
- FR = Feature LBA — LBA bit of the Drive/Head register (D denotes that only the drive bit is used)

SILICONSYSTEMS PROPRIETARY

This document and the information contained within it is confidential and proprietary to SiliconSystems, Inc.
All unauthorized use and/or reproduction is prohibited.

Check Power Mode — 98h, E5h

The Check Power Mode command verifies the device's current power mode. When the device is configured for standby mode or is entering or exiting standby, the BSY bit is set, the Sector Count register set to 00h, and the BSY bit is cleared. In idle mode, BSY is set and the Sector Count register is set to FFh. The BSY bit is then cleared and an interrupt is issued.

Table 31: Check Power Mode — 98h, E5h

| Register | D ₇ | D ₆ | D ₅ | D ₄ | D ₃ | D ₂ | D ₁ | D ₀ |
|---------------|----------------|----------------|----------------|----------------|----------------|----------------|----------------|----------------|
| Feature | | | | | X | | | |
| Sector Count | | | | | X | | | |
| Sector Number | | | | | X | | | |
| Cylinder Low | | | | | X | | | |
| Cylinder High | | | | | X | | | |
| Drive Head | X | X | X | Drive | | | | |
| Command | | | | | | | | 98h or E5h |

SILICONSYSTEMS PROPRIETARY

This document and the information contained within it is confidential and proprietary to SiliconSystems, Inc.
All unauthorized use and/or reproduction is prohibited.

Executive Drive Diagnostic — 90h

The Executive Drive Diagnostic performs an internal read write diagnostic test using (AA55h and 55AAh). If an error is detected in the read/write buffer, the Error register reports the appropriate diagnostic code.

Table 32: Executive Drive Diagnostic — 90h

| Register | D ₇ | D ₆ | D ₅ | D ₄ | D ₃ | D ₂ | D ₁ | D ₀ |
|---------------|----------------|----------------|----------------|----------------|----------------|----------------|----------------|----------------|
| Feature | | | | | X | | | |
| Sector Count | | | | | X | | | |
| Sector Number | | | | | X | | | |
| Cylinder Low | | | | | X | | | |
| Cylinder High | | | | | X | | | |
| Drive Head | X | X | X | | | | | Drive |
| Command | | | | | | | | 90h |

SILICONSYSTEMS PROPRIETARY

This document and the information contained within it is confidential and proprietary to SiliconSystems, Inc.
All unauthorized use and/or reproduction is prohibited.

Format Track — 50h

The Format Track command formats the common solid-state memory array.

Table 33: Format Track — 50h

| Register | D ₇ | D ₆ | D ₅ | D ₄ | D ₃ | D ₂ | D ₁ | D ₀ |
|---------------|--------------------------|----------------|----------------|----------------|------------------------|----------------|----------------|----------------|
| Feature | X | | | | | | | |
| Sector Count | Sector Count | | | | | | | |
| Sector Number | Sector Number (LBA7-0) | | | | | | | |
| Cylinder Low | Cylinder Low (LBA15-8) | | | | | | | |
| Cylinder High | Cylinder High (LBA23-16) | | | | | | | |
| Drive Head | 1 | LBA | 1 | Drive | Head Number (LBA27-24) | | | |
| Command | 50h | | | | | | | |

SILICONSYSTEMS PROPRIETARY

This document and the information contained within it is confidential and proprietary to SiliconSystems, Inc.
All unauthorized use and/or reproduction is prohibited.

Identify Drive — ECh

Issued by the host, the Identify Drive command provides 256 bytes of drive attribute data (i.e., sector size, count, and so on) The identify drive data structure is detailed in the following table.

Table 34: Identify Drive — ECh

| Register | D ₇ | D ₆ | D ₅ | D ₄ | D ₃ | D ₂ | D ₁ | D ₀ |
|---------------|----------------|----------------|----------------|----------------|----------------|----------------|----------------|----------------|
| Feature | | | | | X | | | |
| Sector Count | | | | | X | | | |
| Sector Number | | | | | X | | | |
| Cylinder Low | | | | | X | | | |
| Cylinder High | | | | | X | | | |
| Drive Head | X | X | X | Drive | | | X | |
| Command | | | | | ECh | | | |

SILICONSYSTEMS PROPRIETARY

This document and the information contained within it is confidential and proprietary to SiliconSystems, Inc.
All unauthorized use and/or reproduction is prohibited.

*Identify Drive — Drive Attribute Data***Table 35: Identify Drive — Drive Attribute Data**

| Word Address | Data Default | Bytes | Data Description |
|--------------|--------------|-------|---|
| 0 | 045Ah | 2 | General configuration bit information <ul style="list-style-type: none"> • 15: Non-magnetic disk • 14: Formatting speed latency permissible gap needed • 13: Track Offset option supported • 12: Data Strobe Offset option supported • 11: Over 0.5% rotational speed difference • 10: Disk transfer rate >10Mbps • 9: 10Mbps >= disk transfer rate >5Mbps • 8: 5Mbps >= disk transfer rate • 7: Removable cartridge drive • 6: Fixed drive • 5: Spindle Motor Control option executed • 4: Over 15μs changing head time • 3: Non-MFM encoding • 2: Soft sector allocation • 1: Hard sector allocation • 0: Reserved |
| 1 | XXXXh | 2 | Number of cylinders |
| 2 | 0000h | 2 | Reserved |
| 3 | 00XXh | 2 | Number of heads |
| 4 | 0000h | 2 | Number of unformatted bytes per track |
| 5 | XXXXh | 2 | Number of unformatted bytes per sector |
| 6 | XXXXh | 2 | Number of sectors per track |
| 7-8 | XXXXh | 4 | Number of sectors per device |
| 9 | 0000h | 2 | Reserved |
| 10-19 | XXXXh | 20 | Serial number |

SILICONSYSTEMS PROPRIETARY

This document and the information contained within it is confidential and proprietary to SiliconSystems, Inc.
All unauthorized use and/or reproduction is prohibited.

Table 35: Identify Drive — Drive Attribute Data (Continued)

| Word Address | Data Default | Bytes | Data Description |
|--------------|--------------|-------|--|
| 20 | 0001h | 2 | Buffer type <ul style="list-style-type: none"> • 0000h: Not specified • 0001h: A single-ported, single-sector buffer • 0002h: A dual-ported multisector buffer • 0003h: A dual-ported multisector buffer with a read caching |
| 21 | 0001h | 2 | Buffer size in 512-byte increments |
| 22 | 0004h | 2 | Number of ECC bytes passed on read/write long commands |
| 23-26 | XXXXh | 8 | Firmware revision (eight ASCII characters) |
| 27-46 | XXXXh | 40 | Model number (40 ASCII characters) |
| 47 | 0001h | 2 | 7-0: Maximum number of sectors that can be transferred with a Read/Write Multiple command per interrupt |
| 48 | 0000h | 2 | Double word (32 bit) not supported |
| 49 | 0f00h | 2 | <ul style="list-style-type: none"> • 11: IORDY supported • 9: LBA supported • 8: DMA supported |
| 50 | 0000h | 2 | Reserved |
| 51 | 0200h | 2 | 15-8: PIO data transfer cycle timing |
| 52 | 0000h | 2 | 15-8: DMA data transfer cycle timing |
| 53 | 0003h | 2 | <ul style="list-style-type: none"> • 1: Words 64-70 are valid • 0: Words 54-58 are valid |
| 54 | XXXXh | 2 | Current number of cylinders |
| 55 | XXXXh | 2 | Current number of heads |
| 56 | XXXXh | 2 | Current sectors per track |
| 57-58 | XXXXh | 4 | Current capacity in sectors |
| 59 | 010Xh | 2 | 7-0: Current sectors can be transferred with a Read/Write Multiple command per interrupt |
| 60-61 | XXXXh | 4 | Total number of sectors addressable in LBA mode |
| 62 | 0000h | 2 | Single-word DMA modes supported |

SILICONSYSTEMS PROPRIETARY

This document and the information contained within it is confidential and proprietary to SiliconSystems, Inc.
All unauthorized use and/or reproduction is prohibited.

Idle — 97h, E3h

When issued by the host, the device's internal controller sets the BSY bit, enters the Idle mode, clears the BSY bit, and generates an interrupt. If the sector count is non-zero, it is interpreted as a timer count with each count being 5ms, and the automatic power-down mode is enabled. If the sector count is zero, the automatic power-down mode is disabled.

Table 36: Idle — 97h, E3h

| Register | D ₇ | D ₆ | D ₅ | D ₄ | D ₃ | D ₂ | D ₁ | D ₀ |
|---------------|------------------------------|----------------|----------------|----------------|----------------|----------------|----------------|----------------|
| Feature | X | | | | | | | |
| Sector Count | Timer Count (5ms increments) | | | | | | | |
| Sector Number | X | | | | | | | |
| Cylinder Low | X | | | | | | | |
| Cylinder High | X | | | | | | | |
| Drive Head | X | X | X | Drive | X | | | |
| Command | 97h or E3h | | | | | | | |

SILICONSYSTEMS PROPRIETARY

This document and the information contained within it is confidential and proprietary to SiliconSystems, Inc.
All unauthorized use and/or reproduction is prohibited.

Idle Immediate — 95h, E1h

When issued by the host, the device's internal controller sets the BSY bit, enters Idle Mode, clears the BSY bit, and issues an interrupt. The interrupt is issued whether or not the Idle mode is fully entered.

Table 37: Idle Immediate — 95h, E1h

| Register | D ₇ | D ₆ | D ₅ | D ₄ | D ₃ | D ₂ | D ₁ | D ₀ |
|---------------|----------------|----------------|----------------|----------------|----------------|----------------|----------------|----------------|
| Feature | | | | | X | | | |
| Sector Count | | | | | X | | | |
| Sector Number | | | | | X | | | |
| Cylinder Low | | | | | X | | | |
| Cylinder High | | | | | X | | | |
| Drive Head | X | X | X | Drive | | | X | |
| Command | 95h or E1h | | | | | | | |

SILICONSYSTEMS PROPRIETARY

This document and the information contained within it is confidential and proprietary to SiliconSystems, Inc.
All unauthorized use and/or reproduction is prohibited.

Initialize Drive Parameters — 91h

Initialize Drive Parameters allows the host to set the sector counts per track and the head counts per cylinder to 1 Fixed. Upon issuance of the command, the device sets the BSY bit and associated parameters, clears the BSY bit, and issues an interrupt.

Table 38: Initialize Drive Parameters — 91h

| Register | D ₇ | D ₆ | D ₅ | D ₄ | D ₃ | D ₂ | D ₁ | D ₀ |
|---------------|----------------------------------|----------------|----------------|----------------|--------------------------------------|----------------|----------------|----------------|
| Feature | X | | | | | | | |
| Sector Count | Sector Count (Number of Sectors) | | | | | | | |
| Sector Number | X | | | | | | | |
| Cylinder Low | X | | | | | | | |
| Cylinder High | X | | | | | | | |
| Drive Head | X | 0 | X | Drive | Head Number (Number of Heads — 1) | | | |
| Command | 91h | | | | | | | |

SILICONSYSTEMS PROPRIETARY

This document and the information contained within it is confidential and proprietary to SiliconSystems, Inc.
All unauthorized use and/or reproduction is prohibited.

Recalibrate — 1Xh

The Recalibrate command sets the cylinder low and high, head number to 0h, and sector number to 1h in CHS mode. In LBA mode (i.e., LBA = 1), the sector number is set to 0h.

Table 39: Recalibrate — 1Xh

| Register | D ₇ | D ₆ | D ₅ | D ₄ | D ₃ | D ₂ | D ₁ | D ₀ |
|---------------|----------------|----------------|----------------|----------------|----------------|----------------|----------------|----------------|
| Feature | | | | | X | | | |
| Sector Count | | | | | X | | | |
| Sector Number | | | | | X | | | |
| Cylinder Low | | | | | X | | | |
| Cylinder High | | | | | X | | | |
| Drive Head | 1 | LBA | 1 | Drive | | | X | |
| Command | | | | | | | | 1Xh |

SILICONSYSTEMS PROPRIETARY

This document and the information contained within it is confidential and proprietary to SiliconSystems, Inc.
All unauthorized use and/or reproduction is prohibited.

Read Buffer — E4h

The Read Buffer command allows the host to read the contents of the sector buffer. When issued, the device sets the BSY bit and sets up the sector buffer data in preparation for the read operation. When the data is ready, the DRQ bit is set and the BSY bit in the Status register are set and cleared, respectively.

Table 40: Read Buffer — E4h

| Register | D ₇ | D ₆ | D ₅ | D ₄ | D ₃ | D ₂ | D ₁ | D ₀ |
|---------------|----------------|----------------|----------------|----------------|----------------|----------------|----------------|----------------|
| Feature | | | | | X | | | |
| Sector Count | | | | | X | | | |
| Sector Number | | | | | X | | | |
| Cylinder Low | | | | | X | | | |
| Cylinder High | | | | | X | | | |
| Drive Head | X | X | X | Drive | | | X | |
| Command | | | | | E4h | | | |

SILICONSYSTEMS PROPRIETARY

This document and the information contained within it is confidential and proprietary to SiliconSystems, Inc.
All unauthorized use and/or reproduction is prohibited.

Read DMA — C8h

The Read DMA command allows the host to read data using the DMA transfer protocol.

Note: This function does not apply to SiliconDrives that have DMA disabled.

Table 41: Read DMA — C8h

| Register | D ₇ | D ₆ | D ₅ | D ₄ | D ₃ | D ₂ | D ₁ | D ₀ |
|---------------|--------------------------|----------------|----------------|----------------|------------------------|----------------|----------------|----------------|
| Feature | X | | | | | | | |
| Sector Count | Sector Count | | | | | | | |
| Sector Number | Sector Number (LBA7-0) | | | | | | | |
| Cylinder Low | Cylinder Low (LBA15-8) | | | | | | | |
| Cylinder High | Cylinder High (LBA23-16) | | | | | | | |
| Drive Head | 1 | LBA | 1 | Drive | Head Number (LBA27-24) | | | |
| Command | C8h | | | | | | | |

SILICONSYSTEMS PROPRIETARY

This document and the information contained within it is confidential and proprietary to SiliconSystems, Inc.
All unauthorized use and/or reproduction is prohibited.

Read Multiple — C4h

The Read Multiple command executes similarly to the Read Sector command, with the exception that interrupts are issued only when a block containing the counts of sectors defined by the Set Multiple command is transferred.

Table 42: Read Multiple — C4h

| Register | D ₇ | D ₆ | D ₅ | D ₄ | D ₃ | D ₂ | D ₁ | D ₀ |
|---------------|--------------------------|----------------|----------------|----------------|------------------------|----------------|----------------|----------------|
| Feature | X | | | | | | | |
| Sector Count | Sector Count | | | | | | | |
| Sector Number | Sector Number (LBA7-0) | | | | | | | |
| Cylinder Low | Cylinder Low (LBA15-8) | | | | | | | |
| Cylinder High | Cylinder High (LBA23-16) | | | | | | | |
| Drive Head | 1 | LBA | 1 | Drive | Head Number (LBA27-24) | | | |
| Command | C4h | | | | | | | |

SILICONSYSTEMS PROPRIETARY

This document and the information contained within it is confidential and proprietary to SiliconSystems, Inc.
All unauthorized use and/or reproduction is prohibited.

Read Sector — 20h, 21h

The Read Sector command allows the host to read sectors 1 to 256 as specified in the Sector Count register. If the sector count is set to 0h, all 256 sectors of data are made available. When the command code is issued and the first sector of data has been transferred to the buffer, the DRQ bit is set. The Read Sector command is terminated by writing the cylinder, head, and sector number of the last sector read in the task file. On error, the read operation is aborted in the errant sector.

Table 43: Read Sector — 20h, 21h

| Register | D ₇ | D ₆ | D ₅ | D ₄ | D ₃ | D ₂ | D ₁ | D ₀ |
|---------------|--------------------------|----------------|----------------|----------------|------------------------|----------------|----------------|----------------|
| Feature | X | | | | | | | |
| Sector Count | Sector Count | | | | | | | |
| Sector Number | Sector Number (LBA7-0) | | | | | | | |
| Cylinder Low | Cylinder Low (LBA15-8) | | | | | | | |
| Cylinder High | Cylinder High (LBA23-16) | | | | | | | |
| Drive Head | 1 | LBA | 1 | Drive | Head Number (LBA27-24) | | | |
| Command | 20h or 21h | | | | | | | |

SILICONSYSTEMS PROPRIETARY

This document and the information contained within it is confidential and proprietary to SiliconSystems, Inc.
All unauthorized use and/or reproduction is prohibited.

Read Long Sector(s) — 22h, 23h

The Read Long Sector(s) command operates similarly to the Read Sector(s) command, with the exception that it transfers requested data sectors and ECC data. The long instruction ECC byte transfer for Long commands is a byte transfer at a fixed length of 4 bytes.

Table 44: Read Long Sector(s) — 22h, 23h

| Register | D ₇ | D ₆ | D ₅ | D ₄ | D ₃ | D ₂ | D ₁ | D ₀ |
|---------------|--------------------------|----------------|----------------|----------------|------------------------|----------------|----------------|----------------|
| Feature | X | | | | | | | |
| Sector Count | X | | | | | | | |
| Sector Number | Sector Number (LBA7-0) | | | | | | | |
| Cylinder Low | Cylinder Low (LBA15-8) | | | | | | | |
| Cylinder High | Cylinder High (LBA23-16) | | | | | | | |
| Drive Head | 1 | LBA | 1 | Drive | Head Number (LBA27-24) | | | |
| Command | 22h or 23h | | | | | | | |

SILICONSYSTEMS PROPRIETARY

This document and the information contained within it is confidential and proprietary to SiliconSystems, Inc.
All unauthorized use and/or reproduction is prohibited.

Read Verify Sector(s) — 40h, 41h

The Read Verify Sector(s) command operates similarly to the Read Sector(s) command, with the exception that it does not set the DRQ bit and does not transfer data to the host. When the requested sectors are verified, the onboard controller clears the BSY bit and issues an interrupt.

Table 45: Read Verify Sector(s) — 40h, 41h

| Register | D ₇ | D ₆ | D ₅ | D ₄ | D ₃ | D ₂ | D ₁ | D ₀ |
|---------------|--------------------------|----------------|----------------|----------------|------------------------|----------------|----------------|----------------|
| Feature | X | | | | | | | |
| Sector Count | Sector Count | | | | | | | |
| Sector Number | Sector Number (LBA7-0) | | | | | | | |
| Cylinder Low | Cylinder Low (LBA15-8) | | | | | | | |
| Cylinder High | Cylinder High (LBA23-16) | | | | | | | |
| Drive Head | 1 | LBA | 1 | Drive | Head Number (LBA27-24) | | | |
| Command | 40h or 41h | | | | | | | |

SILICONSYSTEMS PROPRIETARY

This document and the information contained within it is confidential and proprietary to SiliconSystems, Inc.
All unauthorized use and/or reproduction is prohibited.

Seek — 7Xh

The Seek command seeks and picks up the head to the tracks specified in the task file. When the command is issued, the solid-state memory chips do not need to be formatted. After an appropriate amount of time, the DSC bit is set.

Table 46: Seek — 7Xh

| Register | D ₇ | D ₆ | D ₅ | D ₄ | D ₃ | D ₂ | D ₁ | D ₀ |
|---------------|--------------------------|----------------|----------------|----------------|------------------------|----------------|----------------|----------------|
| Feature | X | | | | | | | |
| Sector Count | X | | | | | | | |
| Sector Number | Sector Number (LBA7-0) | | | | | | | |
| Cylinder Low | Cylinder Low (LBA15-8) | | | | | | | |
| Cylinder High | Cylinder High (LBA23-16) | | | | | | | |
| Drive Head | 1 | LBA | 1 | Drive | Head Number (LBA27-24) | | | |
| Command | 7Xh | | | | | | | |

SILICONSYSTEMS PROPRIETARY

This document and the information contained within it is confidential and proprietary to SiliconSystems, Inc.
All unauthorized use and/or reproduction is prohibited.

Set Features — EFh

The Set Features command allows the host to configure the feature set of the device according to the attributes listed in [Table 48](#).

Table 47: Set Features — EFh

| Register | D ₇ | D ₆ | D ₅ | D ₄ | D ₃ | D ₂ | D ₁ | D ₀ |
|---------------|----------------|----------------|----------------|----------------|----------------|----------------|----------------|----------------|
| Feature | Feature | | | | | | | |
| Sector Count | | | | | X | | | |
| Sector Number | | | | | X | | | |
| Cylinder Low | | | | | X | | | |
| Cylinder High | | | | | X | | | |
| Drive Head | X | X | X | Drive | | | X | |
| Command | EFh | | | | | | | |

Table 48: Set Features' Attributes

| Feature | Operation |
|---------|---|
| 01h | Enable 8-bit data transfer |
| 66h | Disable reverting to power on defaults |
| 81h | Disable 8-bit data transfer |
| BBh | 4 bytes of data apply on Read/Write Long commands |
| CCh | Enable revert to power on defaults |

On power-up or following a hardware reset, the device is set to the default mode 81h.

SILICONSYSTEMS PROPRIETARY

This document and the information contained within it is confidential and proprietary to SiliconSystems, Inc.
All unauthorized use and/or reproduction is prohibited.

Set Multiple Mode — C6h

The Set Multiple Mode command allows the host to access the drive via Read Multiple and Write Multiple ATA commands. Additionally, the command sets the block count (i.e., the number of sectors within the block) for the Read/Write Multiple command. The sector count per block is set in the Sector Count register.

Table 49: Set Multiple Mode — C6h

| Register | D ₇ | D ₆ | D ₅ | D ₄ | D ₃ | D ₂ | D ₁ | D ₀ |
|---------------|----------------|----------------|----------------|----------------|----------------|----------------|----------------|----------------|
| Feature | X | | | | | | | |
| Sector Count | Sector Count | | | | | | | |
| Sector Number | X | | | | | | | |
| Cylinder Low | X | | | | | | | |
| Cylinder High | X | | | | | | | |
| Drive Head | X | X | X | Drive | X | | | |
| Command | C6h | | | | | | | |

SILICONSYSTEMS PROPRIETARY

This document and the information contained within it is confidential and proprietary to SiliconSystems, Inc.
All unauthorized use and/or reproduction is prohibited.

Set Sleep Mode — 99h, E6h

The Set Sleep Mode command allows the host to set the device in sleep mode. When the onboard controller transitions to sleep mode, it clears the BSY bit and issues an interrupt. The device interface then becomes inactive. Sleep mode can be exited by issuing either a hardware or software reset.

Table 50: Set Sleep Mode — 99h, E6h

| Register | D ₇ | D ₆ | D ₅ | D ₄ | D ₃ | D ₂ | D ₁ | D ₀ |
|---------------|----------------|----------------|----------------|----------------|----------------|----------------|----------------|----------------|
| Feature | | | | | X | | | |
| Sector Count | | | | | X | | | |
| Sector Number | | | | | X | | | |
| Cylinder Low | | | | | X | | | |
| Cylinder High | | | | | X | | | |
| Drive Head | X | X | X | Drive | | | X | |
| Command | | | | | | | | 99h or E6h |

SILICONSYSTEMS PROPRIETARY

This document and the information contained within it is confidential and proprietary to SiliconSystems, Inc.
All unauthorized use and/or reproduction is prohibited.

Standby — 96h, E2h

When the Standby command is issued by the host, it transitions the device into standby mode. If the Sector Count register is set to a value other than 0h, the Auto Powerdown function is enabled and the device returns to Idle mode.

Table 51: Standby — 96h, E2h

| Register | D ₇ | D ₆ | D ₅ | D ₄ | D ₃ | D ₂ | D ₁ | D ₀ |
|---------------|---------------------------------|----------------|----------------|----------------|----------------|----------------|----------------|----------------|
| Feature | X | | | | | | | |
| Sector Count | Timer Count (5ms x Timer Count) | | | | | | | |
| Sector Number | X | | | | | | | |
| Cylinder Low | X | | | | | | | |
| Cylinder High | X | | | | | | | |
| Drive Head | X | X | X | Drive | X | | | |
| Command | 96h or E2h | | | | | | | |

SILICONSYSTEMS PROPRIETARY

This document and the information contained within it is confidential and proprietary to SiliconSystems, Inc.
All unauthorized use and/or reproduction is prohibited.

Standby Immediate — 94h, E0h

When the Standby Immediate command is issued by the host, it transitions the device into standby mode.

Table 52: Standby Immediate — 94h, E0h

| Register | D ₇ | D ₆ | D ₅ | D ₄ | D ₃ | D ₂ | D ₁ | D ₀ |
|---------------|----------------|----------------|----------------|----------------|----------------|----------------|----------------|----------------|
| Feature | | | | | X | | | |
| Sector Count | | | | | X | | | |
| Sector Number | | | | | X | | | |
| Cylinder Low | | | | | X | | | |
| Cylinder High | | | | | X | | | |
| Drive Head | X | X | X | Drive | | | X | |
| Command | 94h or E0h | | | | | | | |

SILICONSYSTEMS PROPRIETARY

This document and the information contained within it is confidential and proprietary to SiliconSystems, Inc.
All unauthorized use and/or reproduction is prohibited.

Write Buffer — E8h

The Write Buffer command allows the host to rewrite the contents of the 512- byte data buffer with the wanted data.

Table 53: Write Buffer — E8h

| Register | D ₇ | D ₆ | D ₅ | D ₄ | D ₃ | D ₂ | D ₁ | D ₀ |
|---------------|----------------|----------------|----------------|----------------|----------------|----------------|----------------|----------------|
| Feature | | | | | X | | | |
| Sector Count | | | | | X | | | |
| Sector Number | | | | | X | | | |
| Cylinder Low | | | | | X | | | |
| Cylinder High | | | | | X | | | |
| Drive Head | X | X | X | Drive | | | X | |
| Command | E8h | | | | | | | |

SILICONSYSTEMS PROPRIETARY

This document and the information contained within it is confidential and proprietary to SiliconSystems, Inc.
All unauthorized use and/or reproduction is prohibited.

Write DMA — CAh

The Write DMA command allows the host to write data using the DMA transfer protocol.

Note: This function does not apply to SiliconDrives that have DMA disabled.

Table 54: Write DMA — CAh

| Register | D ₇ | D ₆ | D ₅ | D ₄ | D ₃ | D ₂ | D ₁ | D ₀ |
|---------------|-------------------------|----------------|----------------|----------------|-----------------------|----------------|----------------|----------------|
| Feature | X | | | | | | | |
| Sector Count | Sector Count | | | | | | | |
| Sector Number | Sector Number (LBA7-0) | | | | | | | |
| Cylinder Low | Cylinder Low(LBA15-8) | | | | | | | |
| Cylinder High | Cylinder High(LBA23-16) | | | | | | | |
| Drive Head | X | LBA | X | Drive | Head Number(LBA27-24) | | | |
| Command | CAh | | | | | | | |

SILICONSYSTEMS PROPRIETARY

This document and the information contained within it is confidential and proprietary to SiliconSystems, Inc.
All unauthorized use and/or reproduction is prohibited.

Write Multiple — C5h

The Write Multiple command operates in the same manner as the Write Sector command. When issued, the device sets the BSY bit within 400ns and generates an interrupt at the completion of a transferred block of sectors. The DRQ bit is set at the beginning of a block transfer.

Table 55: Write Multiple — C5h

| Register | D ₇ | D ₆ | D ₅ | D ₄ | D ₃ | D ₂ | D ₁ | D ₀ |
|---------------|-------------------------|----------------|----------------|----------------|-----------------------|----------------|----------------|----------------|
| Feature | X | | | | | | | |
| Sector Count | Sector Count | | | | | | | |
| Sector Number | Sector Number (LBA7-0) | | | | | | | |
| Cylinder Low | Cylinder Low(LBA15-8) | | | | | | | |
| Cylinder High | Cylinder High(LBA23-16) | | | | | | | |
| Drive Head | X | LBA | X | Drive | Head Number(LBA27-24) | | | |
| Command | C5h | | | | | | | |

SILICONSYSTEMS PROPRIETARY

This document and the information contained within it is confidential and proprietary to SiliconSystems, Inc.
All unauthorized use and/or reproduction is prohibited.

Write Sector(s) — 30h, 31h

The Write Sector(s) command writes from 1 to 256 sectors as specified in the Sector Count register. A sector count of 0 requests 256 sectors. When issued, the device sets the BSY bit within 400ns and generates an interrupt at the completion of a transferred block of sectors. The DRQ bit is set at the beginning of a block transfer.

Table 56: Write Sector(s) — 30h, 31h

| Register | D ₇ | D ₆ | D ₅ | D ₄ | D ₃ | D ₂ | D ₁ | D ₀ |
|---------------|--------------------------|----------------|----------------|----------------|------------------------|----------------|----------------|----------------|
| Feature | X | | | | | | | |
| Sector Count | Sector Count | | | | | | | |
| Sector Number | Sector Number (LBA7-0) | | | | | | | |
| Cylinder Low | Cylinder Low (LBA15-8) | | | | | | | |
| Cylinder High | Cylinder High (LBA23-16) | | | | | | | |
| Drive Head | X | LBA | X | Drive | Head Number (LBA27-24) | | | |
| Command | 30h or 31h | | | | | | | |

SILICONSYSTEMS PROPRIETARY

This document and the information contained within it is confidential and proprietary to SiliconSystems, Inc.
All unauthorized use and/or reproduction is prohibited.

Write Long Sector(s) — 32h, 33h

The Write Long Sector(s) command operates in the same manner as the Write Sector command — when issued, the device sets the BSY bit within 400ns and generates an interrupt at the completion of a transferred block of sectors. The DRQ bit is set at the beginning of a block transfer.

Table 57: Write Long Sector(s) — 32h, 33h

| Register | D ₇ | D ₆ | D ₅ | D ₄ | D ₃ | D ₂ | D ₁ | D ₀ |
|---------------|--------------------------|----------------|----------------|----------------|------------------------|----------------|----------------|----------------|
| Feature | X | | | | | | | |
| Sector Count | Sector Count | | | | | | | |
| Sector Number | Sector Number (LBA7-0) | | | | | | | |
| Cylinder Low | Cylinder Low (LBA15-8) | | | | | | | |
| Cylinder High | Cylinder High (LBA23-16) | | | | | | | |
| Drive Head | X | LBA | X | Drive | Head Number (LBA27-24) | | | |
| Command | 32h or 33h | | | | | | | |

SILICONSYSTEMS PROPRIETARY

This document and the information contained within it is confidential and proprietary to SiliconSystems, Inc.
All unauthorized use and/or reproduction is prohibited.

Erase Sector(s) — C0h

The Erase Sector(s) command is issued prior to the issuance of a Write Sector(s) or Write Multiple w/o Erase command.

Table 58: Erase Sector(s) — C0h

| Register | D ₇ | D ₆ | D ₅ | D ₄ | D ₃ | D ₂ | D ₁ | D ₀ |
|---------------|--------------------------|----------------|----------------|----------------|------------------------|----------------|----------------|----------------|
| Feature | X | | | | | | | |
| Sector Count | Sector Count | | | | | | | |
| Sector Number | Sector Number (LBA7-0) | | | | | | | |
| Cylinder Low | Cylinder Low (LBA15-8) | | | | | | | |
| Cylinder High | Cylinder High (LBA23-16) | | | | | | | |
| Drive Head | X | LBA | X | Drive | Head Number (LBA27-24) | | | |
| Command | C0h | | | | | | | |

SILICONSYSTEMS PROPRIETARY

This document and the information contained within it is confidential and proprietary to SiliconSystems, Inc.
All unauthorized use and/or reproduction is prohibited.

Request Sense — 03h

The Request Sense command identifies the extended error codes generated by the preceding ATA command. The Request Sense command must be issued immediately following the detection of an error via the Error register.

Table 59: Request Sense — 03h

| Register | D ₇ | D ₆ | D ₅ | D ₄ | D ₃ | D ₂ | D ₁ | D ₀ |
|---------------|----------------|----------------|----------------|----------------|----------------|----------------|----------------|----------------|
| Feature | | | | | X | | | |
| Sector Count | | | | | X | | | |
| Sector Number | | | | | X | | | |
| Cylinder Low | | | | | X | | | |
| Cylinder High | | | | | X | | | |
| Drive Head | 1 | X | 1 | Drive | | | X | |
| Command | | | | | | | | 03h |

The extended error codes are defined in the following table.

Table 60: Extended Error Codes

| Extended Error Codes | Description |
|-------------------------|--|
| 00h | No error detected |
| 01h | Self test is OK (no error) |
| 09h | Miscellaneous error |
| 20h | Invalid command |
| 21h | Invalid address (requested head or sector invalid) |
| 2Fh | Address overflow (address too large) |
| 35h, 36h | Supply or generated voltage out of tolerance |
| 11h | Uncorrectable ECC error |
| 18h | Corrected ECC error |
| 05h, 30h-32h, 37h, 3Eh | Self test of diagnostic failed |
| 10h, 14h | ID not found |
| 3Ah | Spare sectors exhausted |
| 1Fh | Data transfer error/aborted command |
| 0Ch, 38h, 3Bh, 3Ch, 3Fh | Computed media format |
| 03h | Write/erase failed |

SILICONSYSTEMS PROPRIETARY

This document and the information contained within it is confidential and proprietary to SiliconSystems, Inc.
All unauthorized use and/or reproduction is prohibited.

Translate Sector — 87h

The Translate Sector command is not currently supported by the SiliconSystems' SiliconDrive. If the host issues this command, the device responds with 0x00h in the data register.

Table 61: Translate Sector — 87h

| Register | D ₇ | D ₆ | D ₅ | D ₄ | D ₃ | D ₂ | D ₁ | D ₀ |
|---------------|--------------------------|----------------|----------------|----------------|------------------------|----------------|----------------|----------------|
| Feature | X | | | | | | | |
| Sector Count | Sector Count | | | | | | | |
| Sector Number | Sector Number (LBA7-0) | | | | | | | |
| Cylinder Low | Cylinder Low (LBA15-8) | | | | | | | |
| Cylinder High | Cylinder High (LBA23-16) | | | | | | | |
| Drive Head | 1 | LBA | 1 | Drive | Head Number (LBA27-24) | | | |
| Command | 87h | | | | | | | |

SILICONSYSTEMS PROPRIETARY

This document and the information contained within it is confidential and proprietary to SiliconSystems, Inc.
All unauthorized use and/or reproduction is prohibited.

Wear-Level — F5h

The Wear-Level command is supported as an NOP command for the purposes of backward compatibility with the ANSI AT attachment standard. This command sets the Sector Count register to 0x00h.

Table 62: Wear-Level — F5h

| Register | D ₇ | D ₆ | D ₅ | D ₄ | D ₃ | D ₂ | D ₁ | D ₀ |
|---------------|-------------------|----------------|----------------|----------------|----------------|----------------|----------------|----------------|
| Feature | X | | | | | | | |
| Sector Count | Completion Status | | | | | | | |
| Sector Number | X | | | | | | | |
| Cylinder Low | X | | | | | | | |
| Cylinder High | X | | | | | | | |
| Drive Head | X | X | X | Drive | Flag | | | |
| Command | F5h | | | | | | | |

SILICONSYSTEMS PROPRIETARY

This document and the information contained within it is confidential and proprietary to SiliconSystems, Inc.
All unauthorized use and/or reproduction is prohibited.

Write Multiple w/o Erase — CDh

The Write Multiple w/o Erase command functions identically to the Write Multiple command, with the exception that the implied pre-erase (i.e., Erase Sector(s) command) is not issued prior to writing the sectors.

Table 63: Write Multiple w/o Erase — CDh

| Register | D ₇ | D ₆ | D ₅ | D ₄ | D ₃ | D ₂ | D ₁ | D ₀ |
|---------------|--------------------------|----------------|----------------|----------------|------------------------|----------------|----------------|----------------|
| Feature | X | | | | | | | |
| Sector Count | Sector Count | | | | | | | |
| Sector Number | Sector Number (LBA7-0) | | | | | | | |
| Cylinder Low | Cylinder Low (LBA15-8) | | | | | | | |
| Cylinder High | Cylinder High (LBA23-16) | | | | | | | |
| Drive Head | X | LBA | X | Drive | Head Number (LBA27-24) | | | |
| Command | CDh | | | | | | | |

SILICONSYSTEMS PROPRIETARY

This document and the information contained within it is confidential and proprietary to SiliconSystems, Inc.
All unauthorized use and/or reproduction is prohibited.

Write Sector(s) w/o Erase — 38h

The Write Sector(s) w/o Erase command functions similar to the Write Sector command, with the exception that the implied pre-erase (i.e., Erase Sector(s) command) is not issued prior to writing the sectors.

Table 64: Write Sector(s) w/o Erase — 38h

| Register | D ₇ | D ₆ | D ₅ | D ₄ | D ₃ | D ₂ | D ₁ | D ₀ |
|---------------|--------------------------|----------------|----------------|----------------|------------------------|----------------|----------------|----------------|
| Feature | X | | | | | | | |
| Sector Count | Sector Count | | | | | | | |
| Sector Number | Sector Number (LBA7-0) | | | | | | | |
| Cylinder Low | Cylinder Low (LBA15-8) | | | | | | | |
| Cylinder High | Cylinder High (LBA23-16) | | | | | | | |
| Drive Head | X | LBA | X | Drive | Head Number (LBA27-24) | | | |
| Command | 38h | | | | | | | |

SILICONSYSTEMS PROPRIETARY

This document and the information contained within it is confidential and proprietary to SiliconSystems, Inc.
All unauthorized use and/or reproduction is prohibited.

Write Verify — 3Ch

The Write Verify command verifies each sector immediately after it is written. This command performs identically to the Write Sector(s) command, with the added feature of verifying each sector written.

Table 65: Write Verify — 3Ch

| Register | D ₇ | D ₆ | D ₅ | D ₄ | D ₃ | D ₂ | D ₁ | D ₀ |
|---------------|--------------------------|----------------|----------------|----------------|------------------------|----------------|----------------|----------------|
| Feature | X | | | | | | | |
| Sector Count | Sector Count | | | | | | | |
| Sector Number | Sector Number (LBA7-0) | | | | | | | |
| Cylinder Low | Cylinder Low (LBA15-8) | | | | | | | |
| Cylinder High | Cylinder High (LBA23-16) | | | | | | | |
| Drive Head | X | LBA | X | Drive | Head Number (LBA27-24) | | | |
| Command | 3Ch | | | | | | | |

SILICONSYSTEMS PROPRIETARY

This document and the information contained within it is confidential and proprietary to SiliconSystems, Inc.
All unauthorized use and/or reproduction is prohibited.

SALES AND SUPPORT

To order or obtain information on pricing and delivery, contact your SiliconSystems Sales Representative.

PART NUMBERING

NOMENCLATURE

The following table defines the SiliconDrive 1.8" Drive part numbering scheme.

Table 66: Part Numbering Nomenclature

| | | | | |
|---|----------|------------|--|---|
| SSD- | H | YYY | T | -3650 Part number suffix — contact your SiliconSystems' Sales Representative |
| | | | Temperature Range: • Blank = Commercial • I = Industrial | |
| Capacity: 32M = 32MB to 16G = 16GB | | | | |
| Form Factor: • C = CF • D = 2.5" Drive • H = 1.8" Drive • M = Module • P = PC Card | | | | |
| SiliconSystems' SiliconDrive | | | | |

SILICONSYSTEMS PROPRIETARY

This document and the information contained within it is confidential and proprietary to SiliconSystems, Inc.
All unauthorized use and/or reproduction is prohibited.

PART NUMBERS

The following table lists the SiliconDrive's part numbers.

Table 67: Part Numbers

| Part Number | Capacity |
|------------------|----------|
| SSD-H16G(I)-3650 | 16GB |
| SSD-H08G(I)-3650 | 8GB |
| SSD-H04G(I)-3650 | 4GB |
| SSD-H02G(I)-3650 | 2GB |
| SSD-H01G(I)-3650 | 1GB |
| SSD-H51M(I)-3650 | 512MB |
| SSD-H25M(I)-3650 | 256MB |
| SSD-H12M(I)-3650 | 128MB |
| SSD-H64M(I)-3650 | 64MB |
| SSD-H32M(I)-3650 | 32MB |

RoHS 6 OF 6 PRODUCT LABELING — Pb-FREE IDENTIFICATION LABEL



The Pb-free identification label indicates that the enclosed components/ devices and/or assemblies do not contain any lead (i.e., they are lead-free, as defined in RoHS directive 2002/95/ED). The above symbol is on all RoHS 6 of 6 compliant product labels, as seen in [Figure 8](#).

SILICONSYSTEMS PROPRIETARY

This document and the information contained within it is confidential and proprietary to SiliconSystems, Inc.
All unauthorized use and/or reproduction is prohibited.

SAMPLE LABEL



Figure 8: Sample Label

RELATED DOCUMENTATION

For more information, visit www.siliconsystems.com or contact your SiliconSystems Sales Representative.

Table 68: Related Documentation

| SiliconDrive Application-Specific Description Technology | | Document Number |
|--|---|---------------------|
| PowerArmor | Eliminates drive corruption | SSWPxx-PowerArmor-R |
| SiProtect | Protection software for password-required, read/write, or read-only access. | SSANxx-SilDrvSec-R |
| SiSweep | Ultra-fast data erasure | SSANxx-SilDrvSec-R |
| SiPurge | Non-recoverable data erasure | SSANxx-SilDrvSec-R |

SILICONSYSTEMS PROPRIETARY

This document and the information contained within it is confidential and proprietary to SiliconSystems, Inc. All unauthorized use and/or reproduction is prohibited.

[Click here](#)[Click here](#)

SiliconSystems' performance tests, ratings, and product specifications are measured using specific computer systems and/or components and reflect the approximate performance of SiliconSystems' products as measured by those tests. Any difference in system hardware or software design or configuration, as well as system use, may affect actual test results, ratings, and product specifications. SiliconSystems welcomes user comments and reserves the right to revise this document and/or make updates to product specifications, products, or programs described without notice at any time. SiliconSystems makes no representations or warranties regarding this document. The names of actual companies and products mentioned herein are the trademarks of their respective owners.

SiliconSystems™, SiliconDrive™, SiliconDrive Secure™, PowerArmor™, SiSMART™, SiKey™, SiZone™, SiProtect™, SiSecure™, SiSweep™, SiPurge™, SiScrub™, SiliconDrive Blade™, SiliconDrive Edge™, and the SiliconSystems logo are trademarks or registered trademarks of SiliconSystems, Inc. and may be used publicly only with the permission of SiliconSystems and require proper acknowledgement. Other listed names and brands are trademarks or registered trademarks of their respective owners.

© Copyright 2008 by SiliconSystems, Inc. All rights reserved. No part of this publication may be reproduced without the prior written consent of SiliconSystems.

SILICONSYSTEMS PROPRIETARY

This document and the information contained within it is confidential and proprietary to SiliconSystems, Inc.
All unauthorized use and/or reproduction is prohibited.

Free Manuals Download Website

<http://myh66.com>

<http://usermanuals.us>

<http://www.somanuals.com>

<http://www.4manuals.cc>

<http://www.manual-lib.com>

<http://www.404manual.com>

<http://www.luxmanual.com>

<http://aubethermostatmanual.com>

Golf course search by state

<http://golfingnear.com>

Email search by domain

<http://emailbydomain.com>

Auto manuals search

<http://auto.somanuals.com>

TV manuals search

<http://tv.somanuals.com>