

# SINGER TS+ TS380+

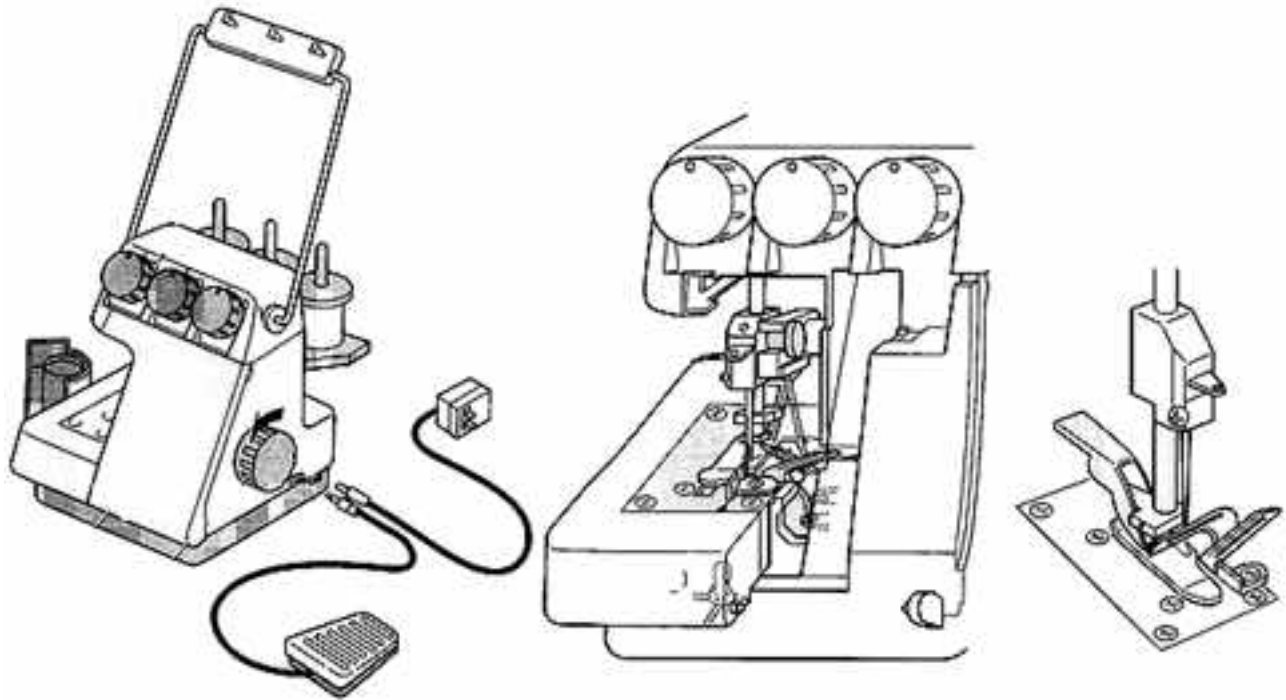

## INSTRUCTION MANUAL

[Table of Contents](#)

[| Next Page](#)

# SINGER TS+ TS380+

## TABLE OF CONTENTS

- MAIN PARTS
- ACCESSORIES
- TRIAL SEWING
- ADJUSTING THREAD TENSION
- PREPARATION FOR THREADING
- TYING ON THREADING
- THREADING PATH A
- THREADING PATH B
- THREADING PATH C
- PREPARATION FOR FORMING  
THREAD CHAIN
- FORMING THREAD CHAIN
- START TO SEW
- SECURING TAIL CHAINS
- TURNING SQUARE CORNER
- HEMMING FUNCTION
- JOIN TWO PIECES OF FABRIC
- CARING FOR YOUR MACHINE
- CHANGING NEEDLE
- PERFORMANCE CHECKLIST

## IMPORTANT SAFEGUARDS

- Never bend loopers and needle while threading and sewing.
- Before connecting machine be sure voltage on AC adaptor matches your electrical outlet
- Disconnect AC adaptor from socket outlet when changing needle or when leaving machine unattended
- Do not pull fabric while sewing as this may bend needle and cause needle breakage or damage to machine
- Handle foot switch with care and avoid dropping it on floor Be sure not to place anything on top of it
- Check machine is threaded correctly before sewing

[Previous Page](#) | [Next Page](#)

# SINGER TS+ TS380+

## MAIN PARTS

1. Thread guide holder
2. Thread guide helps to ensure a smooth flow of thread.
3. Spool pin and cap holds top thread supply and prevents thread tangling.
4. Tension dial controls thread tension. Do not adjust these dials until threading is checked.
5. AC adaptor (9V 650mA) supplies power for your machine.
6. Foot switch runs machine.
7. Sewing speed selector Low and high
8. Handwheel provides a means for raising or lowering the needle.
9. Front cover, covers mechanism. Threading diagram is displayed on right side of machine when the cover is removed
10. Accessory box.

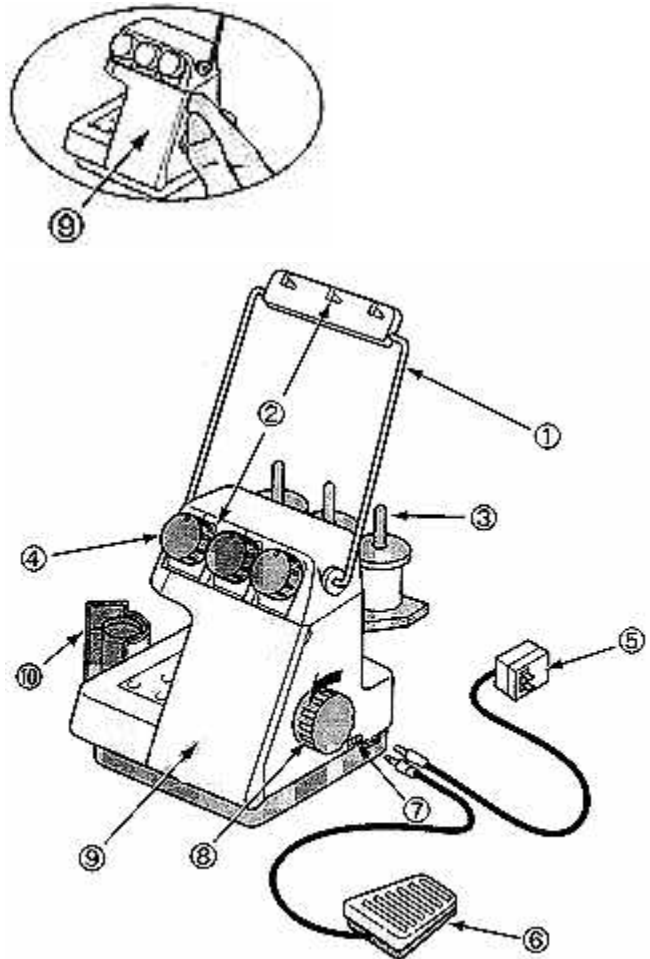

Table of Contents

Previous Page | Next Page

# SINGER TS+ TS380+

## MAIN PARTS continued...

11. Needle clamp body holds needle in machine.
12. Presser bar.
13. Thread guide.
14. Needle-Style 2020 size 14
15. Seam guide keeps seam moving evenly.
16. Lower looper forms lower stitch.
17. Upper looper forms upper stitch.
18. Presser foot holds fabric against feed system.
19. Presser foot lifter lets you raise and lower presser foot. Press down to lift foot.
20. Internal threading light (turns off when foot switch is plugged into machine)

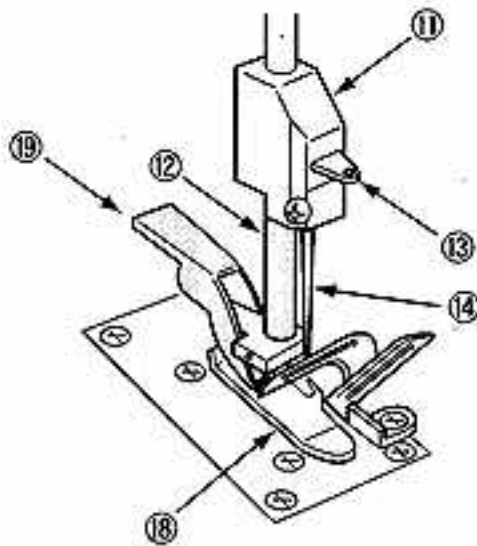
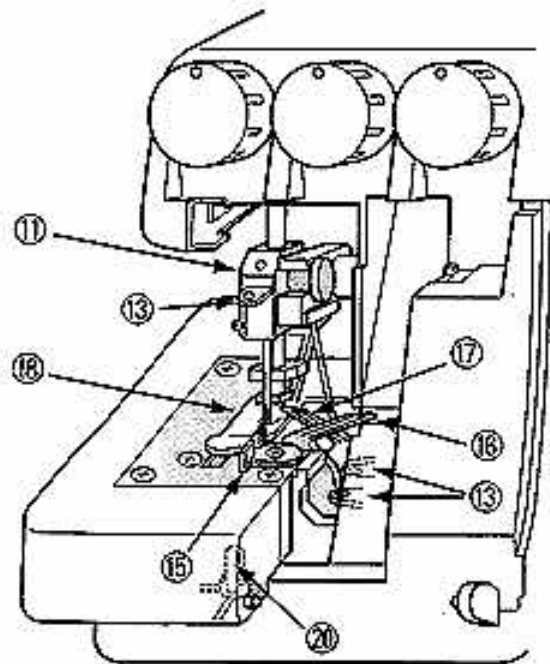

Table of Contents

Previous Page | Next Page

# SINGER TS+ TS380+

## ACCESSORIES



1× Tweezers



3 each× Thread cap  
(small size)



3 each× Thread cap  
(large size)  
(on machine)



2× Threaders



2× Needles  
(1 in machine)



3× Thread spool  
(on machine)

[Table of Contents](#)

[Previous Page](#) | [Next Page](#)

# SINGER TS+ TS380+

## TRIAL SEWING

Take machine out of carton.

Swing thread guide holder up until a slight sound is heard that indicates you have reached the operating position.

Straighten all threads between thread spools and tension dials until thread are taut.

Check thread to make sure it is not tangled under spool or spool stand.

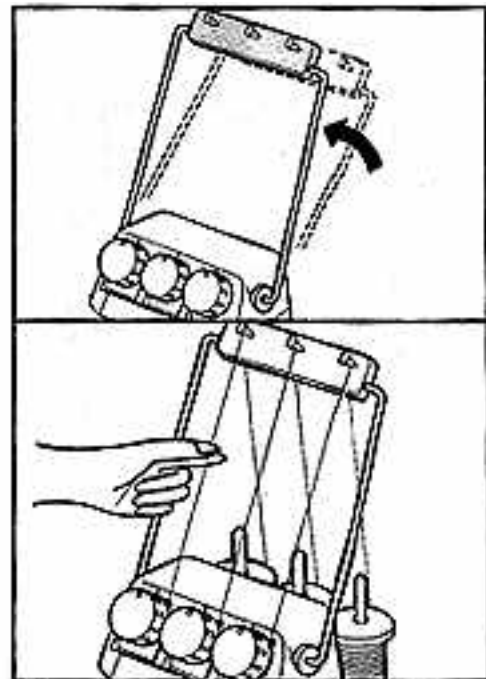

[Table of Contents](#)

[Previous Page](#) | [Next Page](#)

# SINGER TS+ TS380+

## TRIAL SEWING continued...

- Plug in adaptor and foot switch.  
(If not already plugged in)  
**Note: Internal threading light turns off when foot switch is plugged into machine.**
- Press foot switch to continue sewing fabric (under presser foot).
- Lightly guide fabric while sewing.  
**Note: Seam guide is preset for proper width and sewing angle.**
- When seam is complete, continue sewing, lightly pulling fabric towards left rear corner of machine chaining off and forming thread tail.
- Cut thread tail between presser foot and fabric.

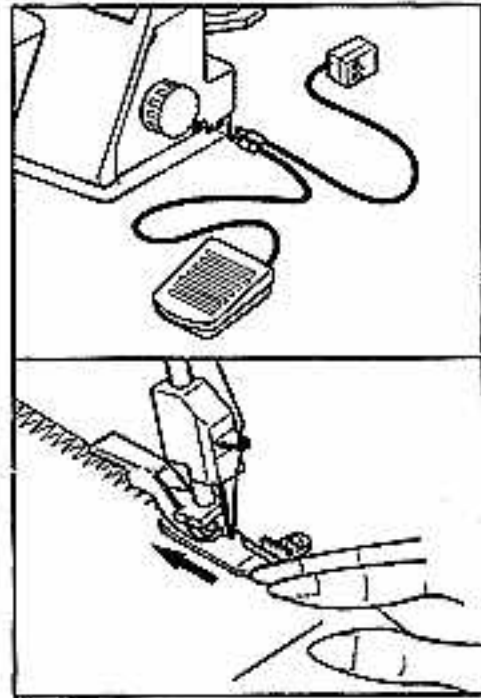

# SINGER TS+ TS380+

## SEW OTHER SIDE

- Lower needle clamp body to lowest setting.
- Use presser foot lifter to raise presser foot.
- Place other side of fabric under presser foot and sew.
- When seam is complete, continue sewing, lightly pulling fabric toward left rear corner of machine chaining off and forming thread tail for next sewing.

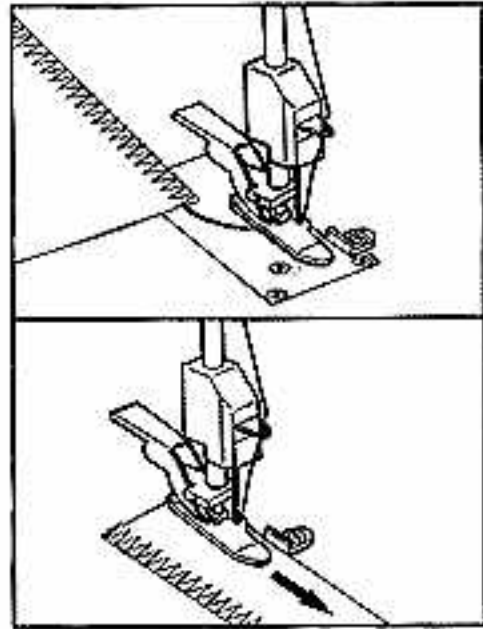

[Table of Contents](#)



[Previous Page](#) | [Next Page](#)



# SINGER TS+ TS380+

## ADJUSTING THREAD TENSION

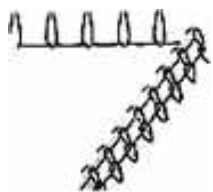
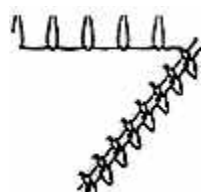
- Thread tension of your machine has been preset at factory to suit most sewing applications  
But some threads and fabrics require readjusting thread tension to improve stitch appearance and prevent skipping.
- Adjust thread tension by slightly turning tension dial.
- Always double check threading before trying to adjust thread tension.
- Make a test sample to find a proper tension before sewing on your fabric.

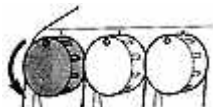
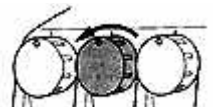
SITUATION	PROPER TENSION	LOWER LOOPER THREAD TOO LOOSE	UPPER LOOPER THREAD TOO LOOSE	NEEDLE THREAD TOO LOOSE
CHARACTERISTIC				
ADJUSTMENT	--	Turn lower looper thread tension dial clockwise to a tighter setting..	Turn upper looper thread tesnion dial clockwise to a tighter setting.	Turn needle thread tension dial clockwise to a tighter setting.
ALTERNATIVE ADJUSTMENT	--			
		Turn needle thread tension dial counter-clockwise to a looser setting.		Turn upper thread tension dial counter-clockwise to a looser setting.

[Table of Contents](#)

[Previous Page](#) | [Next Page](#)

# SINGER TS+ TS380+

## PREPARATION FOR THREADING

- Your machine comes threaded. If you wish to change thread, an easy method for threading is tying on threads. (refer to page 5)
- If machine runs out of thread, it is necessary to rethread machine. (refer to page 6)
- Swing thread guide holder up to operating position. Remove front cover by lifting gently at tab on right side.
- Connect AC adaptor (only) to turn on light for threading.
- For best sewing performance use proper spool cap.

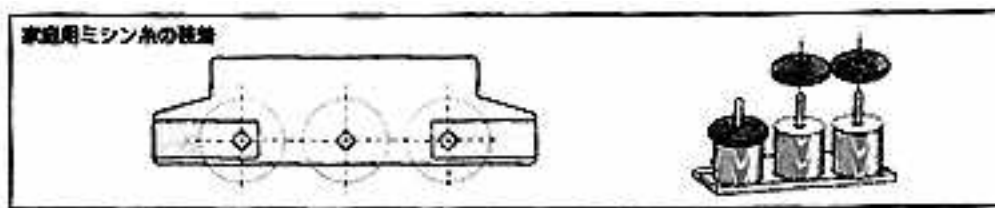

### How To Fix On The Sewing Machine Thread Spools

- Put the three threaded spools into the spool pins.
- Then slide the thread caps (large size) firmly against rim of spool to prevent thread tangling.

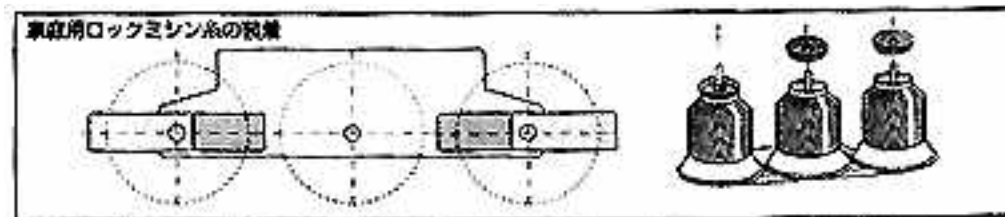

### How To Fix On The Overlock Machine Thread Spools

- Pull the left & right spool pins outwards to proper position.
- Put the three threaded spools into the spool pins.
- Then slide the thread caps (small size) firmly into the center of spools to secure the spools.

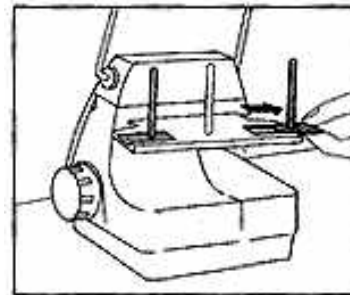

[Table of Contents](#)

[Previous Page](#) | [Next Page](#)

# SINGER TS+ TS380+

## TYING ON THREADING

- Clip thread in front of needle.
- Cut threads close to spools.
- Remove old thread spools.
- Place new thread spool.
- Tie new and old threads.
- Pull needle thread until knot appears.
- Cut knot.
- Thread needle

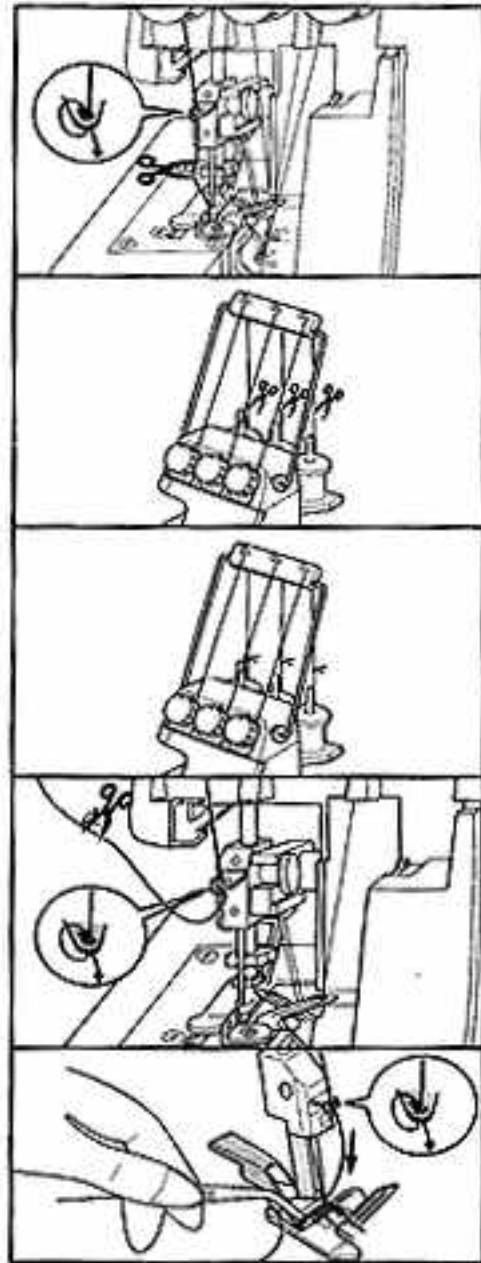

Table of Contents

Previous Page | Next Page

# SINGER TS+ TS380+

## THREADING PATH A (LOWER LOOPER) STEP 1

- Draw thread (A) through guide (A-1)
- Bring thread through guide (A-2).
- Use tweezers to place thread into two discs.
- Use tweezers to guide thread down through front guide (A-3).

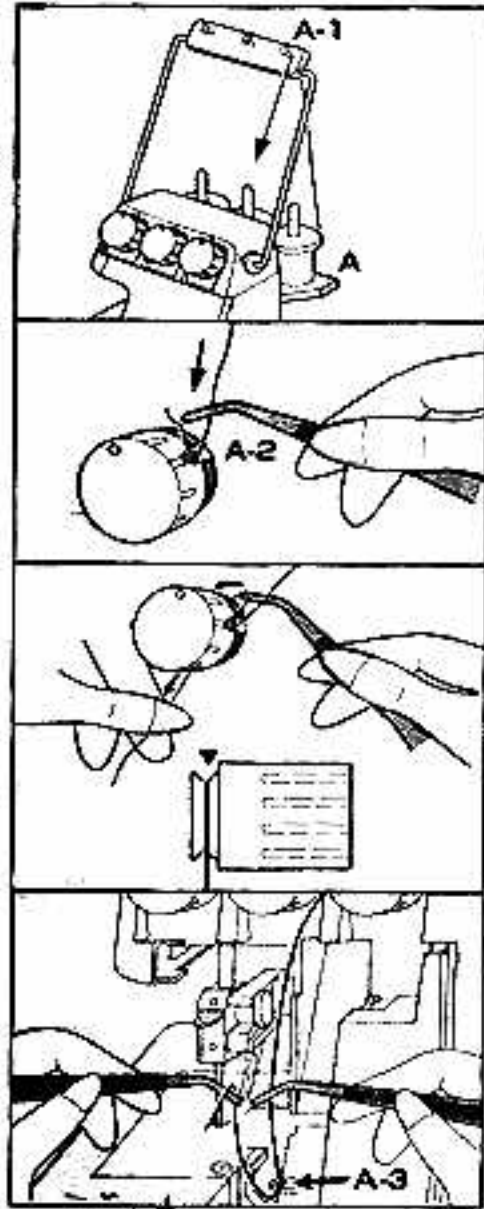

[Table of Contents](#)

[Previous Page](#) | [Next Page](#)

# SINGER TS+ TS380+

## THREADING PATH A continued...

- Raise lower looper to near internal cover (about 3 mm). This is optimum position for threading lower looper.
- Insert threader into left side hole(A-4).
- Hold tweezers in right hand and guide thread through threader.
- Pull threader towards you threading looper from back to front.
- Use tweezers to guide thread. **Place thread between two loopers.**
- Guide thread through right side hole (A-5).
- Draw thread to left.

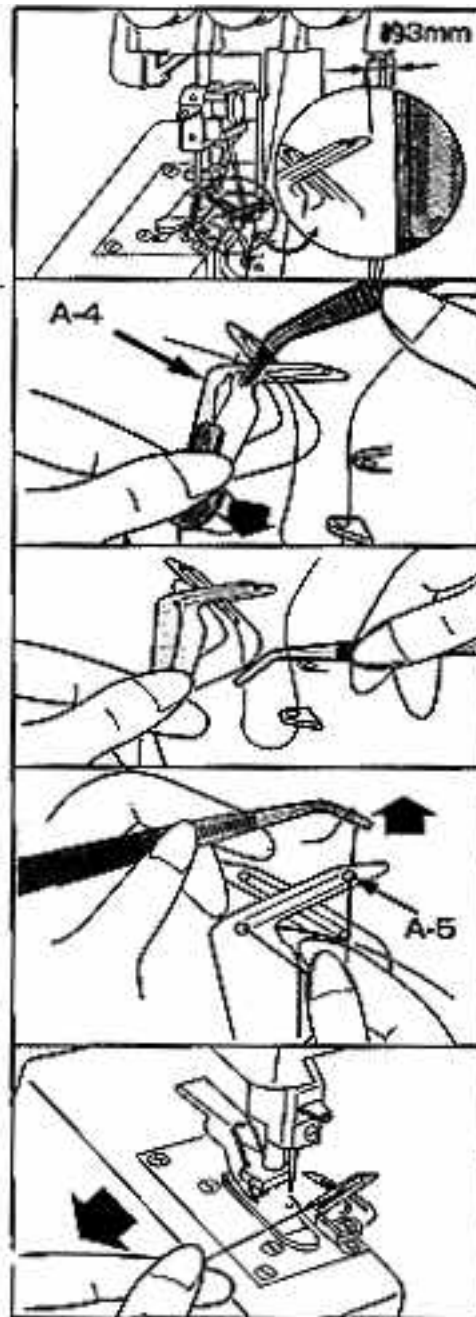

[Table of Contents](#)

[Previous Page](#) | [Next Page](#)

# SINGER TS+ TS380+

## THREADING PATH B (UPPER LOOPER) STEP 2

- Draw thread of spool (B) through guide (B-1).
- Pull thread down to guide (B-2).
- Use tweezers to place thread into two discs.
- Turn handwheel toward you.
- Lower needle clamp body to lowest position. This is optimum position for threading guide (B-3).

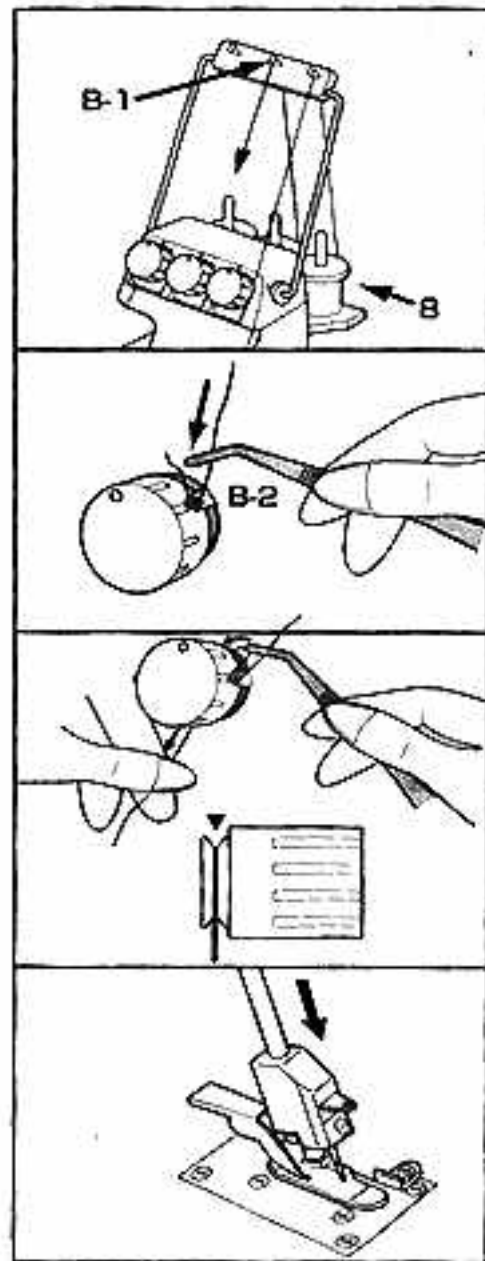

[Table of Contents](#)

[Previous Page](#) | [Next Page](#)

# SINGER TS+ TS380+

## THREADING PATH B continued...

- Guide thread down through rear guide (B-3).
- Place needle clamp body to highest position. This is optimum position for threading upper looper.
- Insert threader into right side hole (B-4).
- Guide thread through threader.
- Pull threader towards you threading looper from back to front.
- Guide thread through left side hole (B-5).
- Draw thread to left.

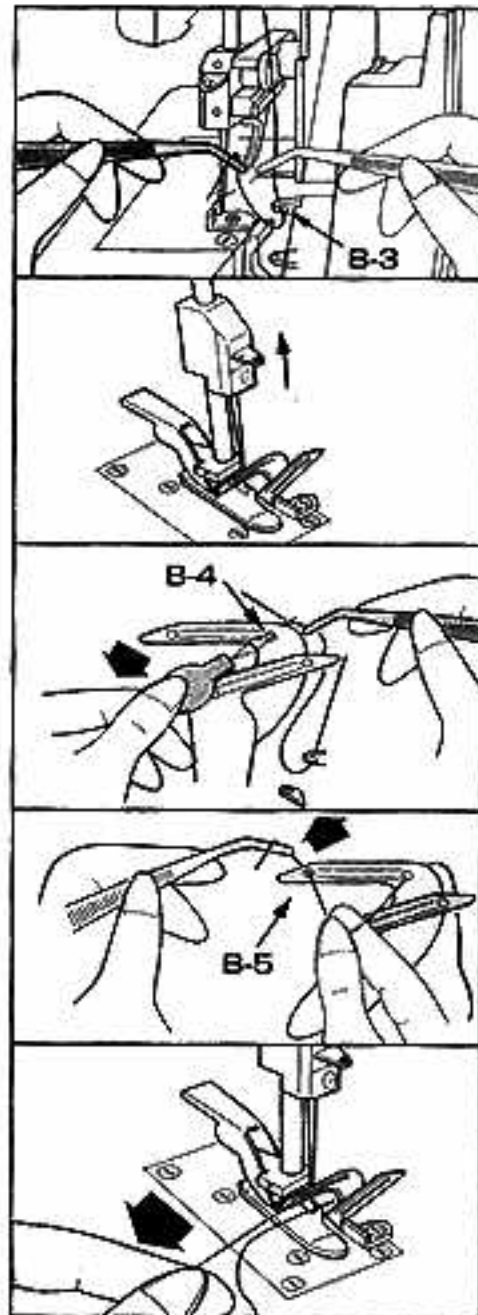

Table of Contents

Previous Page | Next Page

# SINGER TS+ TS380+

## THREADING PATH C (NEEDLE) STEP 3

- Draw thread of spool (C) through guide (C-1).
- Pull thread down to guide (C-2).
- Use tweezers to place thread into two discs.
- Pull thread down through guide (C-3),  
then up and down through it again.

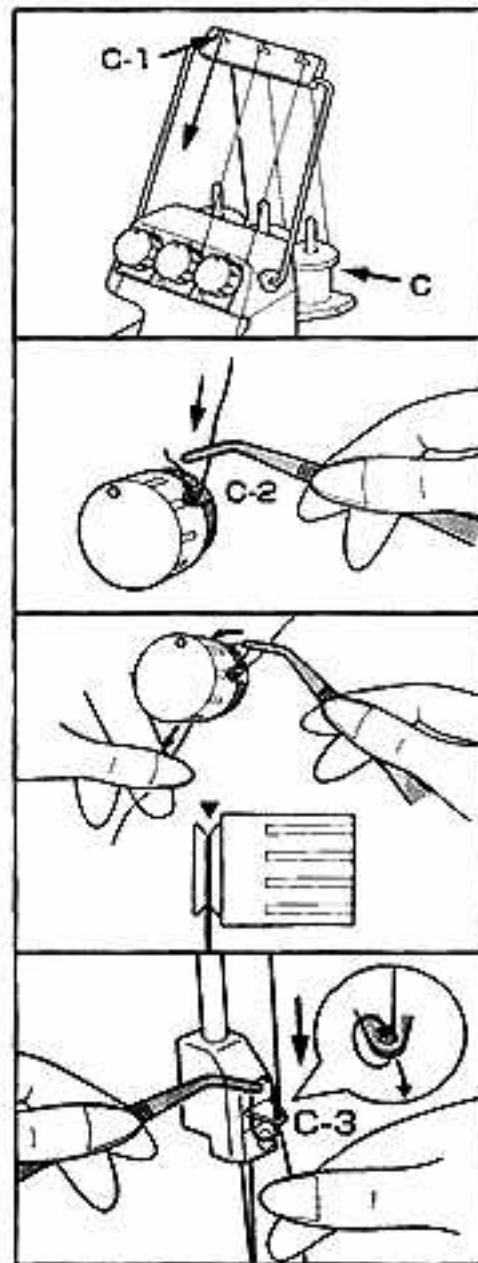

[Table of Contents](#)

[Previous Page](#) | [Next Page](#)



# SINGER TS+ TS380+

## THREADING PATH C continued...

- Thread needle from front to back.
- Draw thread to left.

## PREPARATION FOR FORMING THREAD CHAIN

- Lower needle clamp body to lowest position.
- Collect the three threaded threads and place them under presser foot.

## FORMING THREAD CHAIN

- Hold thread ends at 30° to needle. (towards left rear corner).
- Turn handwheel about 8 times to form thread chain.
- **If chain will not form check threading.**
- After producing chain, start to sew on your fabric.

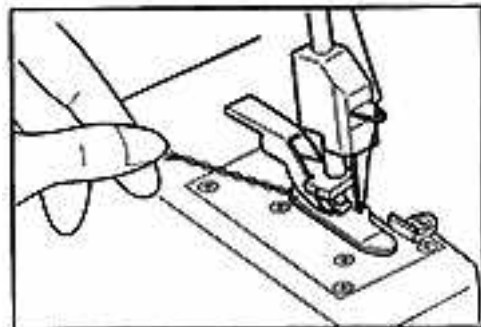
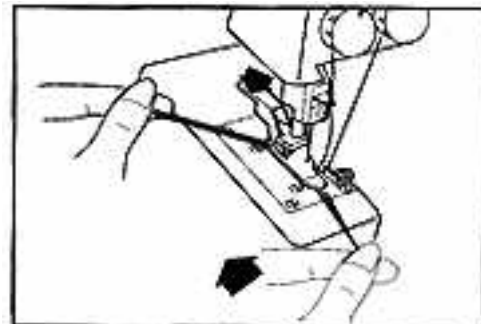
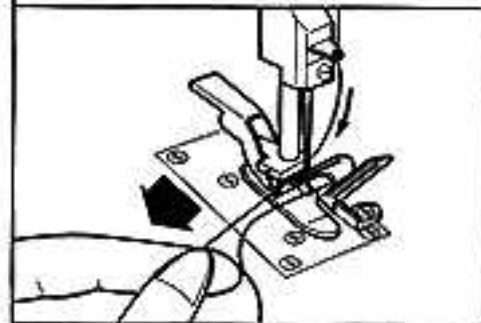
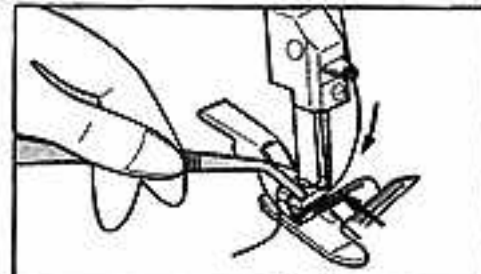

[Table of Contents](#)

[Previous Page](#) | [Next Page](#)

# SINGER TS+ TS380+

## START TO SEW

- Note: Seam guide is preset to limit stitch width to approximately 11 /64 inch (4.2mm).
- Place needle clamp body to lowest position.
- Place thread chain 90 to needle.
- Place fabric under presser foot touching needle and against seam guide.
- Plug in foot switch
- Select High or Low sewing speed.
- Start stitching.
- Lightly guide fabric.
- When seam is completed, continue to sew until enough thread tail available for next sewing.

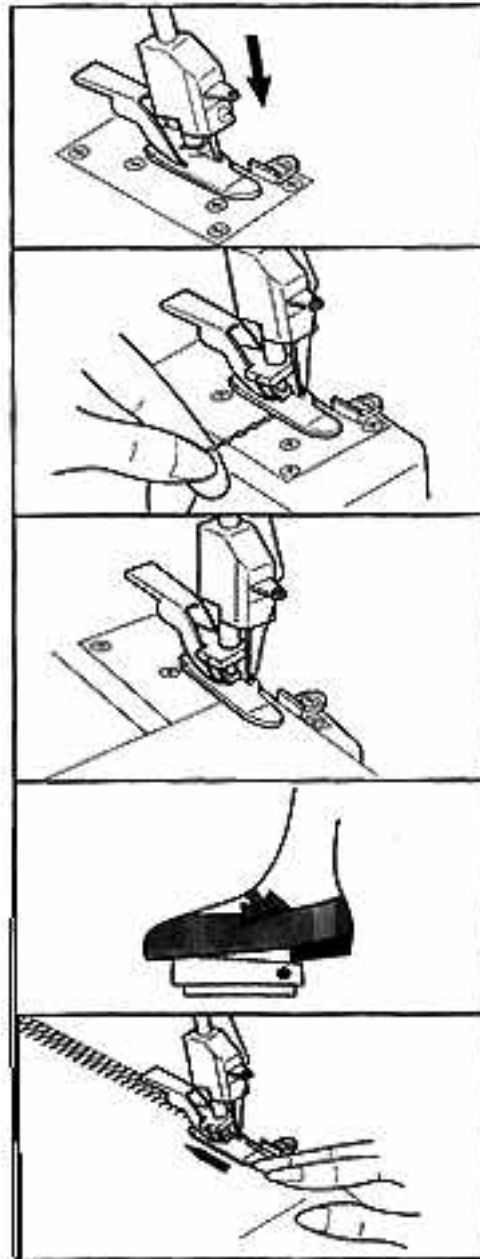

[Table of Contents](#)

[Previous Page](#) | [Next Page](#)

# SINGER TS+ TS380+

## SECURING TAIL CHAINS

- Apply liquid fray preventer.
- Use large needle and thread chains under stitches.

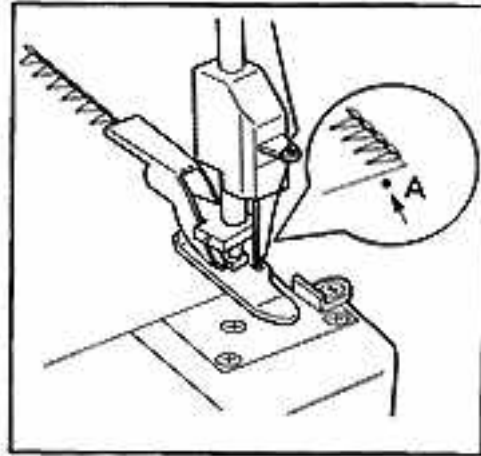

[Table of Contents](#)

[Previous Page](#) | [Next Page](#)

# SINGER TS+ TS380+

## TURNING SQUARE CORNER

### Outside Corner

- Sew to point A, one stitch past end of corner.
- Raise presser foot. (Push down on lever).
- Pivot fabric.
- Insert needle at edge.
- Continue stitching.

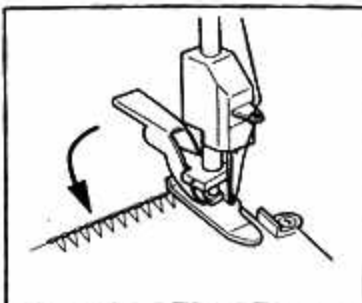
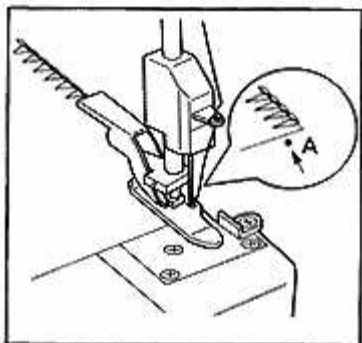

### Inside Corner

- Stitch, stopping on point B.
- Leave needle in fabric.
- Pull fabric to left in straight line.
- Stitch and hold fabric in straight line.

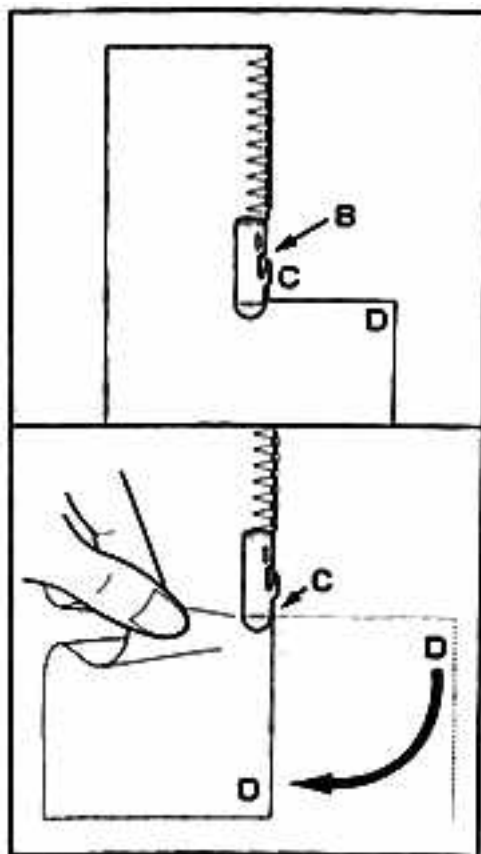

Table of Contents

Previous Page | Next Page

# SINGER TS+ TS380+

## HEMMING FUNCTION

- Fold hem to wrong side.
- Fold hem back as shown.
- Place folded edge against seam guide.
- Using thread that matches fabric
- Stitch making sure needle just barely catches the fold.
- Turn fabric to right side and press.

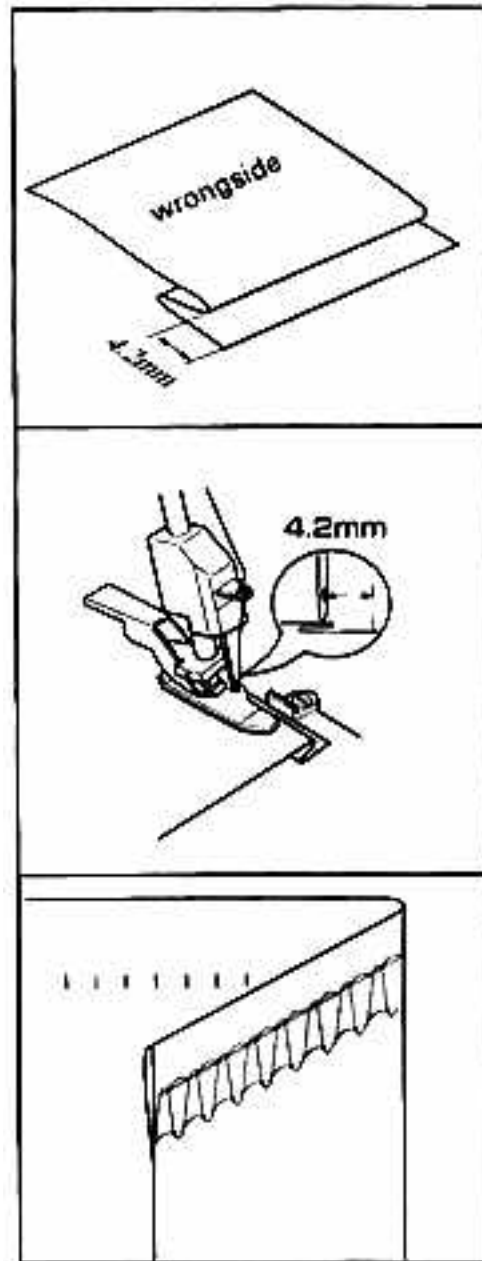

[Table of Contents](#)

[Previous Page](#) | [Next Page](#)

# SINGER TS+ TS380+

## JOIN TWO PIECES OF FABRIC

- Place wrong side of fabric together.
- Start sewing fabric.
- When finish sewing, pull fabric flat and press.

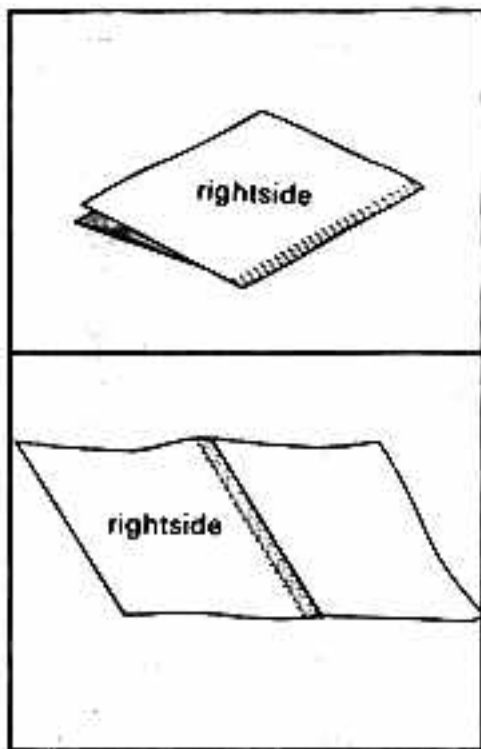

## CARING FOR YOUR MACHINE

- Add one drop of sewing machine oil to highlighted areas after or before using machine.

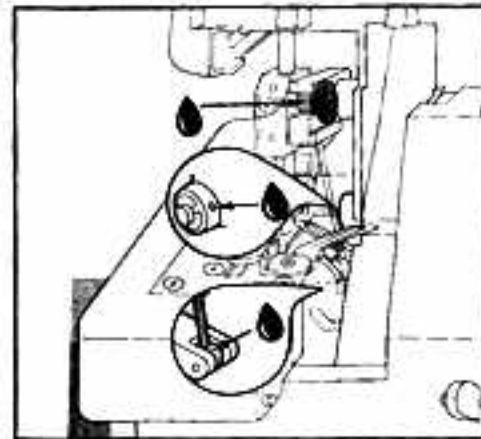

## CHANGING NEEDLE

**Important: For best results, use only Needle style 2020 size 14.**

- Insert flat side of needle to the back as far up as it will go.
- Use screwdriver to tighten the screw.

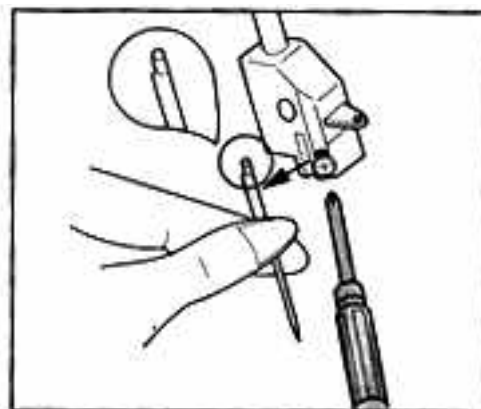

Table of Contents

Previous Page | Next Page

# SINGER TS+ TS380+

## PERFORMANCE CHECKLIST

Whenever sewing difficulty is encountered, make adjustments as noted below:

Condition	Reason	Method of adjustments (reference pages)
When needle breaks.	<ul style="list-style-type: none"> <li>• Needle not inserted properly.</li> <li>• Fabric being pulled too hard.</li> <li>• Loose needle set screw.</li> </ul>	<ul style="list-style-type: none"> <li>• Insert needle correctly or replace with correct needle. <b>(page 11)</b></li> <li>• Do not pull the fabric by hand. Use hand on l to guide the fabric.</li> <li>• Tighten Screw firmly.</li> </ul>
When thread breaks.	<ul style="list-style-type: none"> <li>• Incorrect threading.</li> <li>• Bent needle or needle point damage.</li> <li>• Thread tension too tight.</li> <li>• Thread tangled.</li> <li>• Needle inserted incorrectly.</li> <li>• Thread guide holder not in the right position.</li> </ul>	<ul style="list-style-type: none"> <li>• Thread machine correctly. <b>(pages 6, 7, &amp; 8)</b></li> <li>• Replace needle. <b>(page 11)</b></li> <li>• Adjust tension. <b>(page 4)</b></li> <li>• Thread correctly. <b>(page 6, 7, &amp; 8)</b></li> <li>• Insert needle correctly. <b>(page 11)</b></li> <li>• Swing thread guide holder up to the end. <b>(page 3)</b></li> </ul>
When stitches skip.	<ul style="list-style-type: none"> <li>• Needle bent or needle point damaged.</li> <li>• Needle set loosely.</li> <li>• Incorrect threading.</li> <li>• Wrong needle used.</li> </ul>	<ul style="list-style-type: none"> <li>• Replace needle. <b>(page 11)</b></li> <li>• Set needle firmly in position. <b>(page 11)</b></li> <li>• Thread machine correctly. <b>(page 6, 7, &amp; 8)</b></li> <li>• Use Cat. 2020-014.</li> </ul>
When stitches are irregular.	<ul style="list-style-type: none"> <li>• Thread tension not balanced.</li> </ul>	<ul style="list-style-type: none"> <li>• Adjust tension. <b>(page 4)</b></li> </ul>
When Fabric puckers.	<ul style="list-style-type: none"> <li>• Thread tension too tight.</li> <li>• Threading incorrect or tangled.</li> </ul>	<ul style="list-style-type: none"> <li>• Adjust tension. <b>(page 4)</b></li> <li>• Rethread machine. <b>(page 6, 7, &amp; 8)</b></li> </ul>
When the machine does not operate.	<ul style="list-style-type: none"> <li>• Power line plug not connected.</li> </ul>	<ul style="list-style-type: none"> <li>• Connect with power source. <b>(page 3)</b></li> </ul>

Table of Contents

Previous Page

## Free Manuals Download Website

<http://myh66.com>

<http://usermanuals.us>

<http://www.somanuals.com>

<http://www.4manuals.cc>

<http://www.manual-lib.com>

<http://www.404manual.com>

<http://www.luxmanual.com>

<http://aubethermostatmanual.com>

Golf course search by state

<http://golfingnear.com>

Email search by domain

<http://emailbydomain.com>

Auto manuals search

<http://auto.somanuals.com>

TV manuals search

<http://tv.somanuals.com>