

## #6-1276 DRIVEN DISC HUB REPLACEMENT KIT for SNAPPER WALK BEHIND MOWERS

**INTRODUCTION:** This kit is to be used on all SNAPPER 21" Steel Deck and Rear Discharge (Aluminum) Walk Behind Mowers. This service repair kit is to be used in case of wear or damage to driven disc & hub assembly. **WARNING!:** STOP ENGINE! DISCONNECT SPARK PLUG WIRE AND SECURE THE END AWAY FROM THE PLUG TO PREVENT PREMATURE ENGINE STARTING. **NOTE:** The rubber drive disc #2-3364 should be replaced when worn down to within 1/16" of the plate, worn unevenly or if the rubber has been peeled. Proceed as follows:

**STEP 1:** Remove clip and disconnect transfer rod from speed control lever and driven disc assembly. See Figure 1.

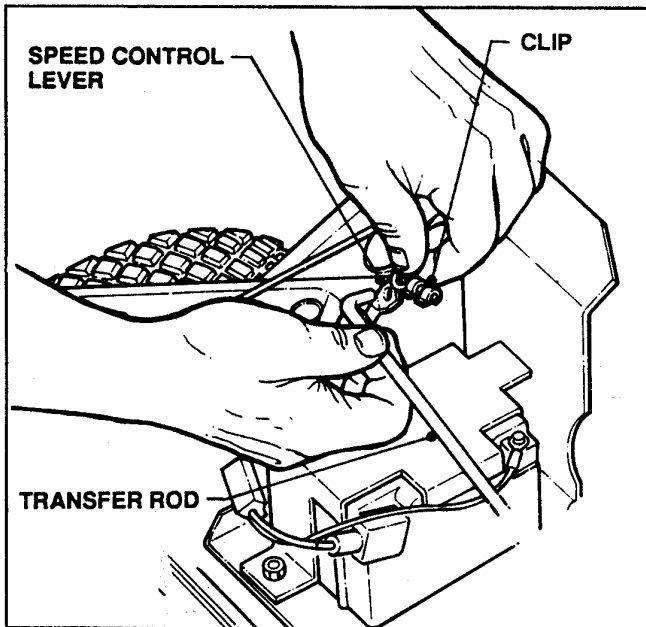

FIGURE 1

**STEP 2:** Unhook drive spring as shown in Figure 2 and remove the driven disc assembly by sliding off hex shaft. See Figure 3.

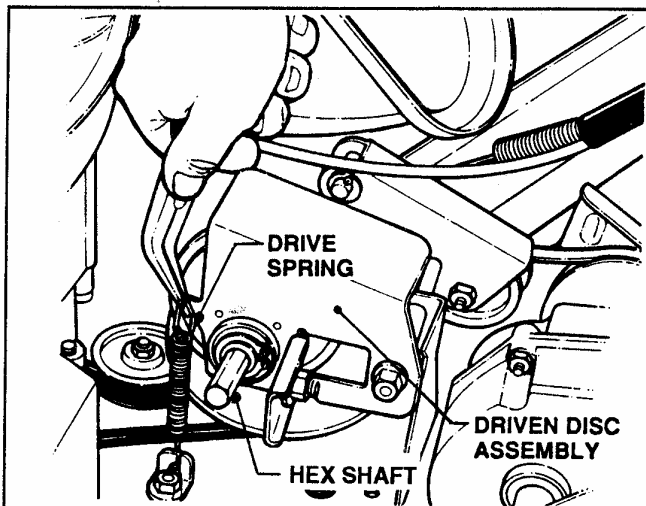

FIGURE 2

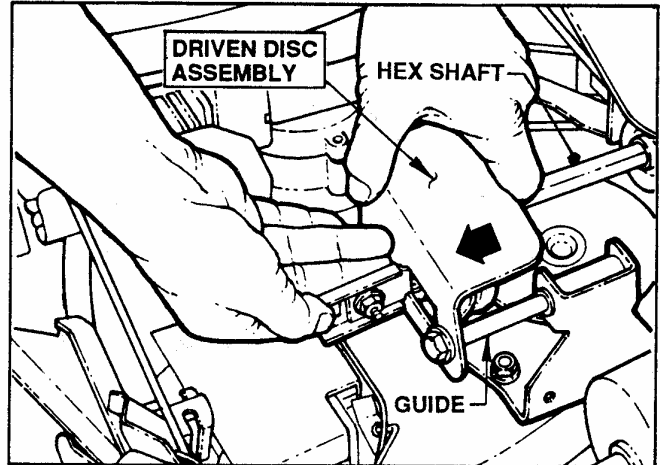

FIGURE 3

**STEP 3:** Remove the five machine screws from the driven disc plate. Separate the plate and rubber disc from the driven disc hub. See Figure 4.

**STEP 4:** Remove snap ring from driven disc hub and trust plate and slide hub out as shown in Figure 4.

**STEP 5:** **NOTE:** The shim washer found in kit must be installed in between disc hub and thrust plate bearing as shown if installing this kit on 21" Steel Deck Model as shown. If installing kit on Rear Discharge (Aluminum) Models **DISCARD** shim washer, it is not needed on these models. Install new driven disc hub into trust plate and secure with snap ring. Make sure snap ring is fastened securely in slot on hub assembly.

**STEP 6:** Reinstall rubber disc or replace with new one using part number mentioned previously. Reinstall plate and secure with five machine screws and tighten with 2 to 3 Ft. Lbs. of torque.

**STEP 7:** Reinstall the driven disc assembly on hex shaft. Reconnect drive spring to driven disc assembly. Reconnect the transfer rod to thrust plate and to the speed control lever with clip.

**STEP 8:** It may be necessary to adjust the driven disc assembly. Move ground speed control lever into highest position and rotate engine with pull rope.

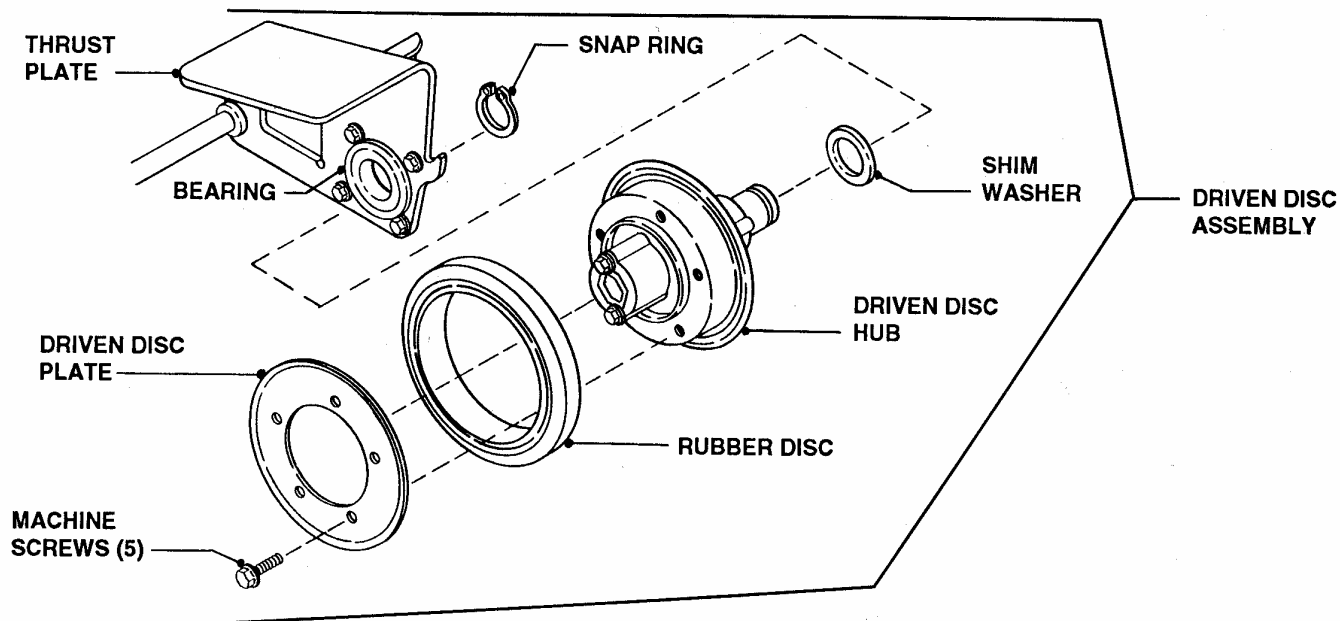

FIGURE 4

**STEP 9:** If properly adjusted, the edge of the driven disc will be 1/8" to 1/4" in from outer edge of the drive disc. See Figure 5.

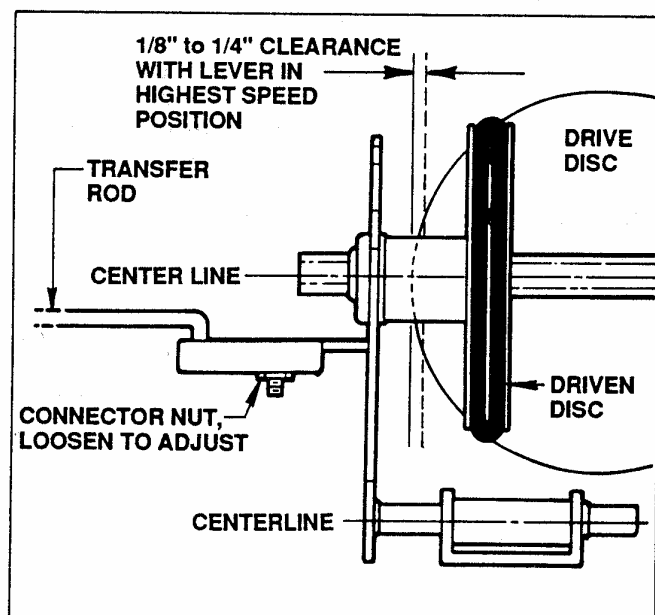

FIGURE 5

**STEP 10:** If adjustment is needed loosen nut on connector, and shift driven disc assembly until desired clearance is achieved as shown in Figure 6. (Connector is slotted to allow disc assembly to slide back and forth). Retighten connector nut. Test mower after adjusting.

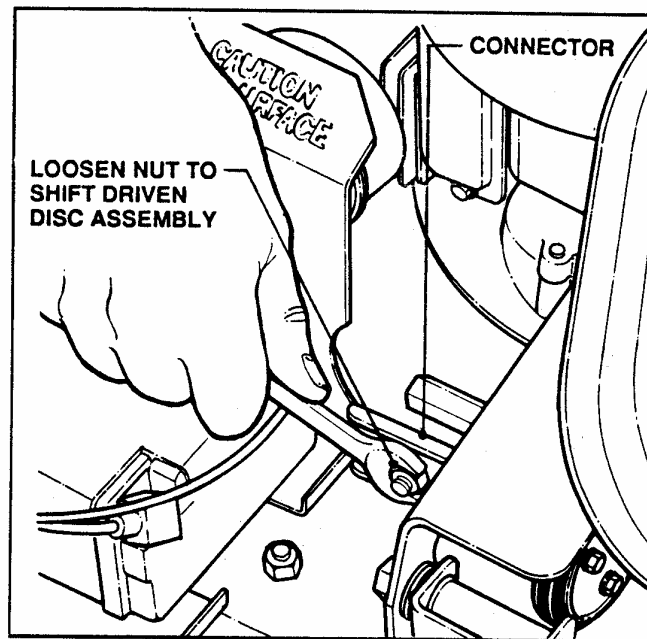

FIGURE 6

**SNAPPER** McDonough, GA., 30253 U.S.A.  
 DIVISION OF FUQUA INDUSTRIES, INC.

## Free Manuals Download Website

<http://myh66.com>

<http://usermanuals.us>

<http://www.somanuals.com>

<http://www.4manuals.cc>

<http://www.manual-lib.com>

<http://www.404manual.com>

<http://www.luxmanual.com>

<http://aubethermostatmanual.com>

Golf course search by state

<http://golfingnear.com>

Email search by domain

<http://emailbydomain.com>

Auto manuals search

<http://auto.somanuals.com>

TV manuals search

<http://tv.somanuals.com>