

# OPERATOR'S MANUAL

## WIDE BODY CART COLLECTOR

Dual Wheel Cart For Use With  
Turbo Collection System

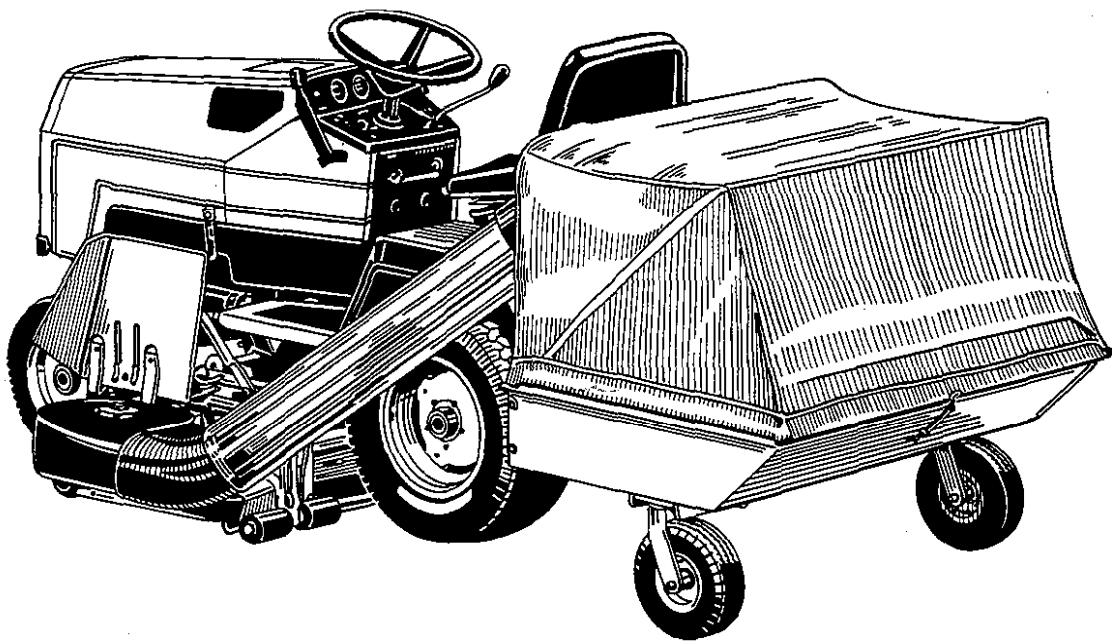

Form 1708219  
Printed in USA  
1/94-1C-CCI

SUNSTAR/1900 SERIES CART  
SOVEREIGN/900 SERIES CART  
MFG. NO. 1691526

LANDLORD/1700 SERIES CART  
MFG. NO. 1692085



# Table of Contents

	Page
Standard Fastener Identification Chart.....	inside Front Cover
Decals .....	1
Specifications .....	1
Decals .....	1
Illustrations and Parts Lists.....	2-3
Cart and Cover Assembly .....	2
Hitch and Tube Assembly – SunStar/1900 Series .....	3
Hitch and Tube Assembly – Landlord0700 Series.....	3
Hitch Assembly – Sovereign/900 Series..	3
Safety Rules .....	4
Carl Assembly.....	5
Cover Assembly .....	6
Hitch Assembly .....	8
SunStar/1900 Series (Mfg. No. 1691526). .....	8
Landlord11700 Series (Mfg. No. 1692086). .....	8
Sovereign1900 Series (Mfg. No. 1691526).....	8
Discharge Tube Installation..	9
Landlord0 700 Series (Mfg. No. 1692085). .....	9
SunStar/1900 Series (Mfg. No. 1691526). .....	10
Sovereign1900 Series (Mfg. No. 1691526). .....	10
Connecting Cart to Tractor .....	10
Maintenance .....	11
Cover .....	11
Wheels .....	11
Tires .....	11
Operation .....	11
Before Operation .....	11
Operation .....	11
Dumping Grass and Leaves .....	11
Operating Without Collection <b>System</b> .....	12
Reinstallation After Removal .....	12
Torque Specifications Chart.....	Inside Rear Cover

## Decals

NOTE: To clean clear mid-tube on Deluxe Grass Catcher wash with warm water and mild soap or detergent. Use a soft clean sponge or cloth. DO NOT use abrasive, alkaline, or petroleum based cleaners.

**MAX. CAPACITY 400 LBS.**

## Specifications

Overall Length .....	42 in.
Width .....	46 in.
Height .....	41.4 in.
Inside Box Length .....	31 in.
Width .....	44 in.
Height .....	7 in.
Box Capacity .....	5 cu. ft.
Weight Capacity .....	400 lbs.
Grass Capacity .....	17 bushels
Pneumatic Tire Size .....	41 0/350 x 4

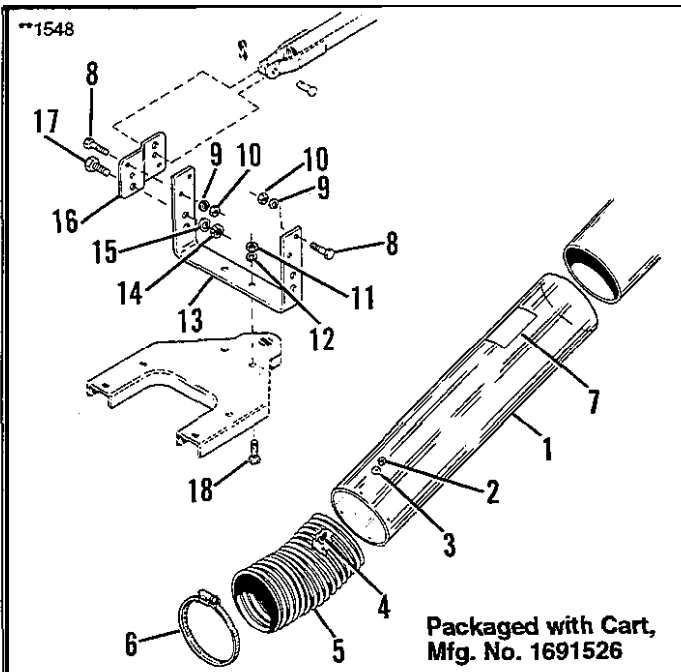

### B. Hitch and Tube Assembly - SunStar/1900 Series

Item	Description	Qty.
1	Tube Assy. (Incl. Ref. No. 38)	1
2	Nut, Hex Full, Lock, #10-32	4
3	Washer, Plain, #10	4
4	Screw, Phillips, Truss Head, #10-32 x 1/2	4
5	Hose	1
6	Clamp, 6"	1
7	Decal, Cleaning Inst.	1
8	Capscrew, Hex Hd., 7/16-14 x 1-1/2	4
9	Lo&washer, 7/16	4
10	Nut, Hex, Full, 7/16	4
11	Nut, Hex, Full, 1/2-13	2
12	Lo&washer, 1/2	2
13	Bracket, Hitch (Frame)	1
14	Nut, Hex, Full, 5/8	2
15	Lockwasher, 5/8	2
16	Bracket, Hitch (Cart)	2
17	Capscrew, Hex Hd., 5/8-11 x 1-1/4	2
18	Capscrew, Hex, 1/2-13 x 1-1/4	2

2371  
2490

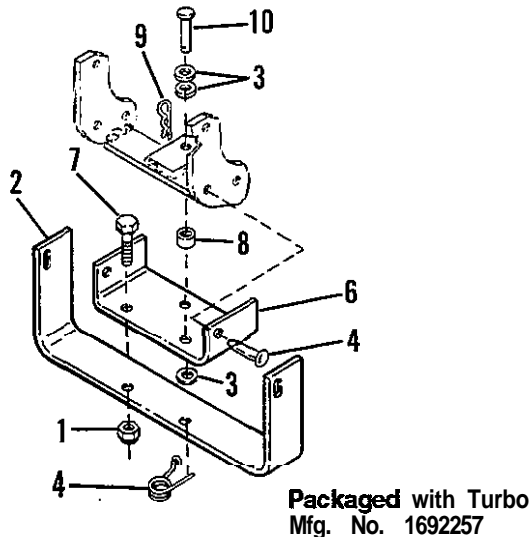

### C. Hitch Assembly - Sovereign/900 Series

**NOTE:** For *Sovereign/900* Series tractors, use tube assembly, parts 1-7 as shown above. The *hitch* assembly is packaged with the *Turbo Blower*, Mfg. No. 1692257. Do not use the hitch assembly, parts 8-18, shown above.

Item	Description	Qty.
1	Locknut, Hex Hd., 1/2-13	2
2	Hitch, U-Bracket	1
3	Washer, Flat, 1/2 x 1 x 9/64	3
4	Clip, Safety	1
5	Pin, Clevis, 7/16 X 1-3/4	2
6	Bracket, Support	1
7	Capscrew, Hex Hd., 1/2-13x1-1/2	2
8	Spacer	1
9	Clip, Spring, 1/8 x 9/16	2
10	Pin, Clevis, 1/2 x 7/8	1

2353

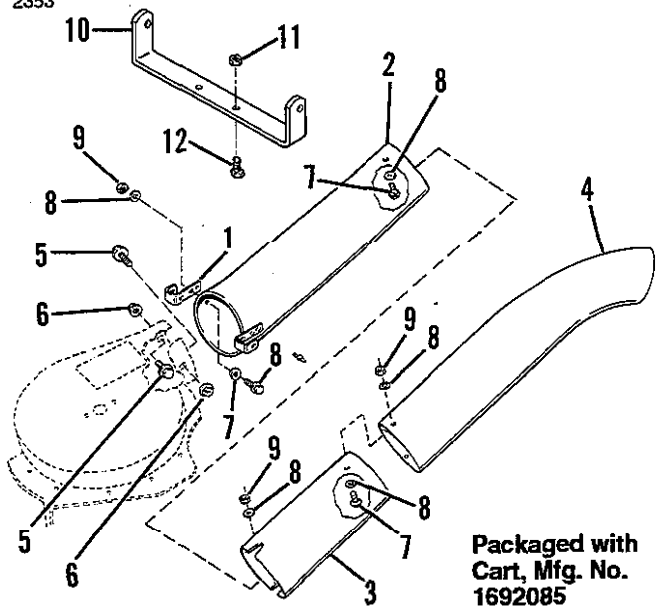

### D. Hitch and Tube Assembly - Landlord11700 Series

Item	Description	Qty.
1	Clip, Spring	1
2	Lower Tube Assy.	1
3	Middle Tube	1
4	Upper Tube	1
5	Carriage Bolt, 1/4-20 x 5/8	2
6	Nut, Hex, Flange, Lock, 1/4-20	2
7	Screw, Truss Hd., 10-32 x 1/2	6
8	Washer, Flat, #10	12
9	Nut-Hex Washer Assembly, 1032	6
10	Hitch, U-Bracket	1
11	Nut, Hex, Lock, 1/2-13	2
12	Capscrew, Hex Hd., 1/2-13 x 1-1/2	2

## Cart Assembly

*NOTE: Sort out the hardware and arrange by size and type. Refer to figure 1.*

1. Install the wheel assemblies (A, figure 2) to the frame (B). Place the head of the swivel wheel on the end of the frame. Align the holes and place four  $3/8$ - $16 \times 1$  hex bolts up through the frame and head of the swivel. Secure with four flat washers ( $13/32$  I.D.,  $7/8$  O.D.) and  $3/8$ - $16$  locknuts.

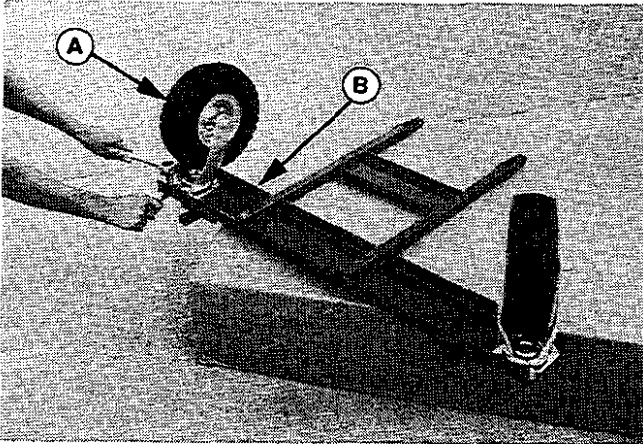

Figure 2  
A. Wheel Assembly  
B. Frame

2. Install the U-bracket (A, figure 3) to the bottom of the box (B). Place the three  $5/16$ - $20 \times 3/4$  slotted truss head bolts and three flat washers ( $1 1/32$  I.D.,  $3/4$  O.D.) through the inside of the box and the U-bracket. Secure with three  $5/16$  lo&washers and nuts.

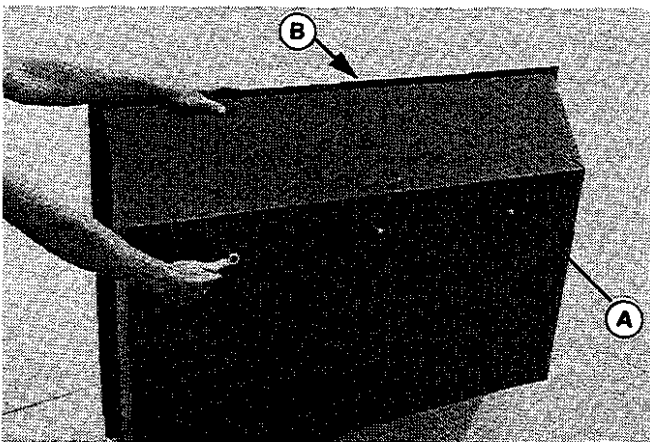

Figure 3  
A. U-Bracket  
B. Box

3. Turn box upside down and install the frame to the U-bracket (figure 4). Align the two prong end (A) in the frame with the ends of the U-bracket and secure with two  $1/2$ - $13 \times 1-1/4$  hex bolts and locknuts. **DO NOT** overtighten the locknuts, since the box pivots at this point for dumping.

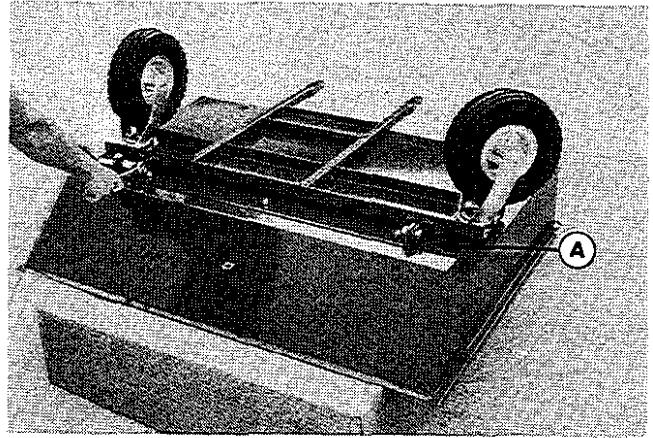

Figure 4  
A. Prong End

*NOTE: The latch handle (A, figure 5) is located on the right hand side on cart, Mfg. No. 169 1526 and on the left hand side on cart, Mfg. No. 1692085.*

4. Turn box with frame upright and install the latch handle (A, figure 5) and two lii handles (B) as follows:
  - a. Latch Handle: Place one  $5/16$ - $18 \times 1$  hex bolt with  $5/16$  spring washer through the inside of the box. Next place a  $5/16$  flat washer over the bolt on the outside of the box, the latch handle, a  $5/16$  flat washer, a  $5/16$  spring washer and a  $5/16$  nut and jam nut. Tighten the nuts so that when the latch handle turns the bolt and nut will not turn. (Be sure the cups of the spring washers are facing toward the box surface on both sides.)
  - b. Lii Handles: Install the two lift handles on the outside of the box. Place two  $1/4$ - $20 \times 1/2$  slotted truss head bolts through the inside of the box and the lii handle. Secure with two  $1/4$  lo&washers and nuts.

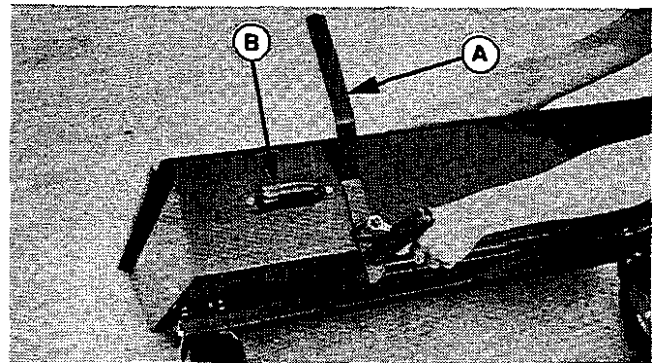

Figure 5  
A. Latch Handle  
B. Lift Handle

- Install the sleeve clamp (C, figure 11) to the connecting sleeve (A) with 1/4-20 x 1/2 slotted truss head screw (D) and nyloc nut (E). Install the connecting sleeve inside the collar of the cover and position sleeve clamp (C) over the support tube (B).

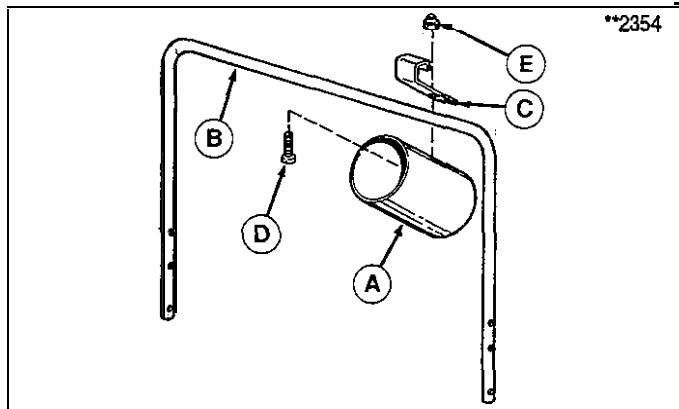

Figure 11

- |                      |                                      |
|----------------------|--------------------------------------|
| A. Connecting Sleeve | D. Truss Head Screw,<br>1/4-20 x 1/2 |
| B. Support Tube      | E. Nyloc Nut                         |
| C. Sleeve Clamp      |                                      |

- Thread the straight rod (A, figure 12) which has an eyelet on each end through the sleeve at the front of the cover.

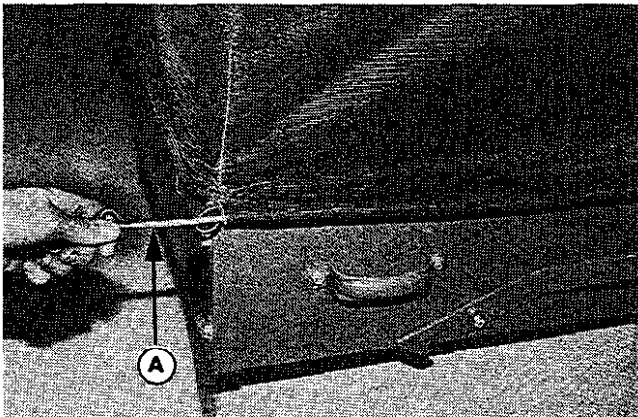

Figure 12

- A. Straight Rod

- Pinch the black cord loop (B, figure 13) and thread it through the eyelet on each end of the rod. Next, pull the loop over the top bolt (C) on each side of the box. The rod gives added support to the cover at the front of the box.
- Inside the cover at the front, there is a long tab with an eyelet on the end. Pull this tab over the top of the support tube (A, figure 14) and back under the support tube before threading it through the slot in the cover. This locking tab (B) secures the cover to the support tube when the cover assembly is locked into the open position for dumping.

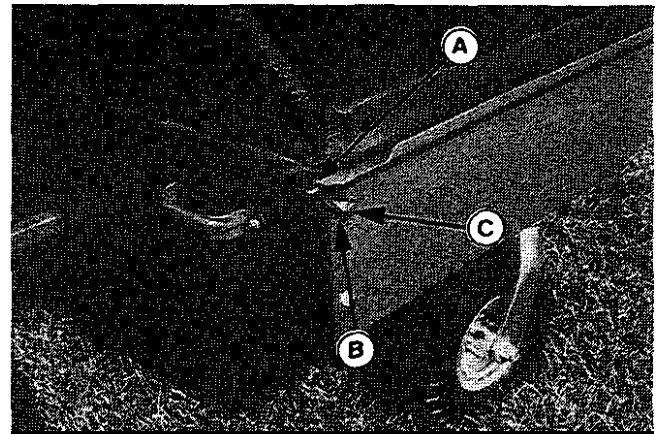

Figure 13

- A. Straight Rod      B. Cord Loop      C. Bolt

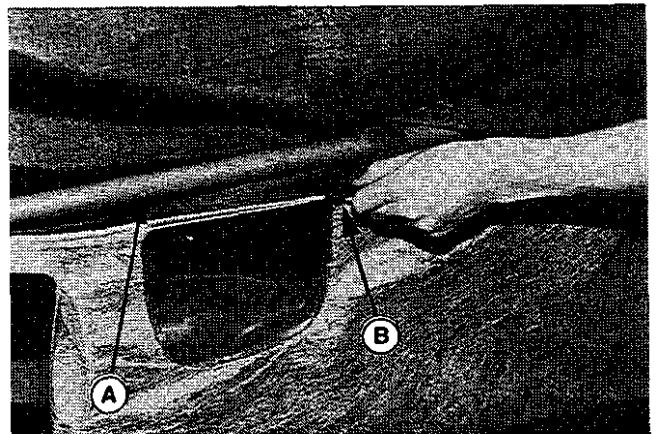

Figure 14

- A. Support Tubes      B. Locking Tab

- Install the six inch rubber strap (A, figure 15) at the back of the box. Hook the strap over the metal loop (B) on the frame rod, which protrudes through the cover. Close the hook with a pair of pliers. Hook the other end of the strap over the door lock (C) on the box.

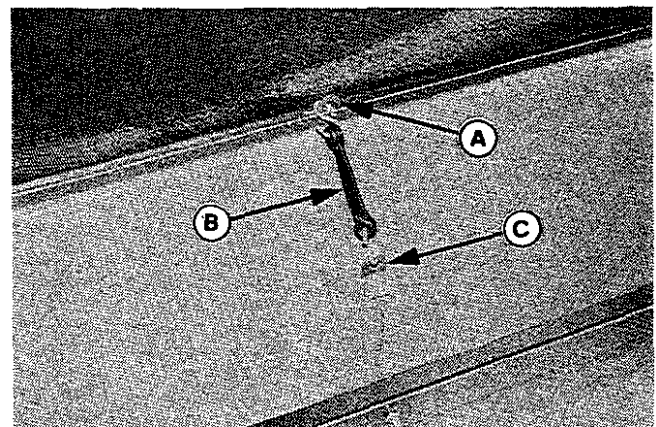

Figure 15

- A. Metal Loop  
B. Rubber Strap  
C. Door Lock

## Discharge Tube Installation

Landlord/1700 Series (Mfg. No. 1692095)

1. Install the spring clip (D, figure 18) with two 10-32 x 1/2 truss head screws (E), four flat washers (F), and two locknuts (G).
2. Install 1/4-20 x 5/8 carriage bolt (H) through hole in turbo housing. Secure with 1/4-20 flange locknut (I).
3. Position the lower tube (C) onto turbo housing and hook inside spring clip onto flange locknut (I, installed in step 2). Mark hole location on opposite side of turbo housing for outer spring clip.
4. Remove lower tube and drill 9/32 hole in turbo housing and install 1/4-20 x 5/8 carriage bolt (H) through hole. Secure with 1/4-20 flange locknut (I).
5. Assemble the upper tube (A) onto middle tube (B) as shown in figure 2 with two 1032 x 1/2 truss head screws (E), four flat washers (F), and two locknuts (G).
6. Install two 10-32 x 1/2 truss head screws (E), four flat washers (F), and two locknuts (G) to the top holes in the lower tube (C). Leave hardware loose.
7. Install upper tubes (A and B) to lower tube (C) and tighten hardware.
8. Install tube assembly into cart sleeve and onto turbo housing. Hook spring clips (D) onto flange locknuts (I) installed on turbo housing.

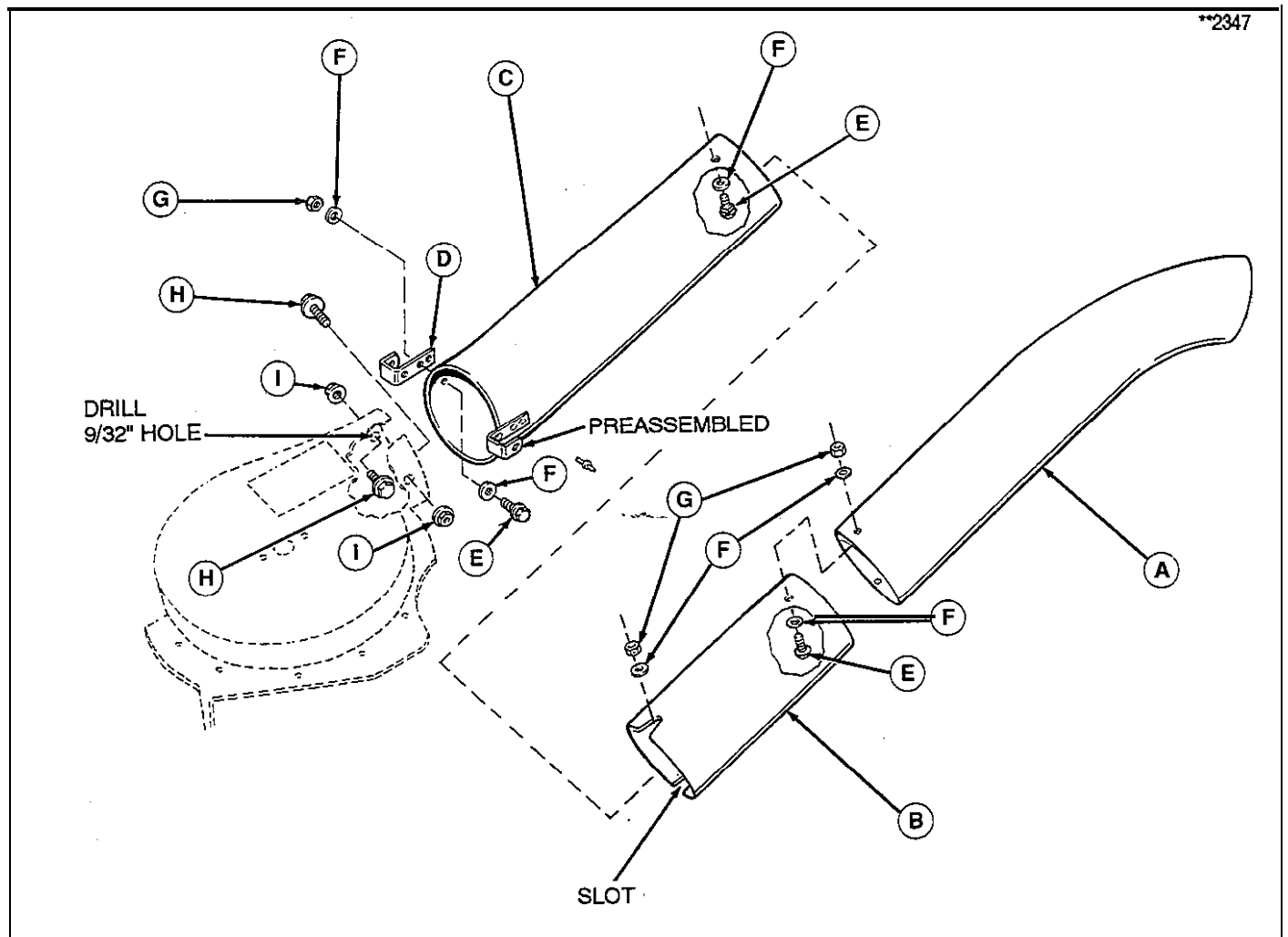

Figure 18

- |                                  |                                |
|----------------------------------|--------------------------------|
| A. Upper Tube                    | F. Washer                      |
| B. Middle Tube                   | G. Locknut, 10-32              |
| C. Lower Tube                    | H. Carriage Bolt, 1/4-20 x 5/8 |
| D. Spring Clip                   | I. flange Locknut, 1/4-20      |
| E. Truss Head Screw, 10-32 x 1/2 |                                |

## Maintenance



### WARNING

The cart cover is subject to wear and deterioration. Check the cover frequently. Use an approved replacement cover.

### Cover

The cover can be rinsed with a hose when dirty. A dirty cover will inhibit the fast flow of grass clippings into the cover. Do not leave grass or leaves in the cart for a long period of time.

### Wheels

Lubricate the wheel assembly before using the cart and as necessary thereafter. A grease fitting is located at swivel base. Use SAE multi-purpose type grease.

### Tires

The tire pressure should be 30 psi.



### WARNING

For safety reasons grass and debris are to be removed only after engine is shut off, key removed, and all moving parts stopped.



### WARNING

Before raising cover, shut off engine, remove key, and set parking brake.



### CAUTION

Weight limit in cart is 400 lbs.

## Operation

### Before Operation

Clear the lawn of all sticks, stones, wire and other debris which may be caught or thrown by the mower blades.

Clean the tube with mild detergent (other products may damage tube). The flow of grass can be seen through the tube while mowing.

Check grass condition. If wet, wait until later in the day. If grass is wet, plugging may occur.

For efficient bagging, air circulation under the mower deck, through the chute and into the bag is very important. For this reason, you should remove grass and debris from underside of mower deck, discharge chute and cover.

The blower, tube and elbow can be removed for cleaning.

## Operation

Grass should be cut often, and not too short. If grass is too long or lush it may be necessary to keep ground speed to a minimum or to cut only half the width to prevent clogging. If grass is high, operate with mower in high cutting position. Cut the grass again in lower cutting position, if desired.

The collector is full when grass builds at the window.

Always operate with throttle at full speed.

### Dumping Grass and Leaves

1. Back the tractor to the desired place for unloading. Shut the tractor's engine off before getting off the tractor's seat.
2. Unhook the strap from the door lock and raise the cover assembly to the open position. Lock the cover in place by hooking the strap to the locking tab in place by hooking the strap to the locking tab (figure 21). Also see figure 22.

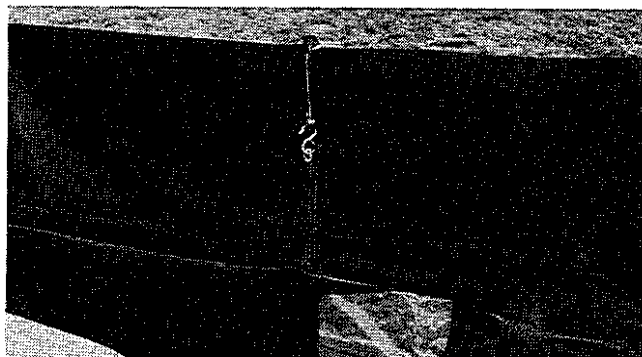

Figure 21

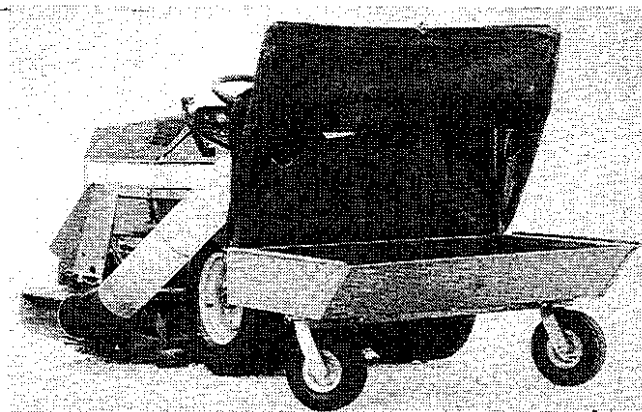



Figure 22

3. Move the latch handle to the unlock position and dump the cart's box using one of the front lift handles. The connecting sleeve will slide off the discharge chute and the cart's box will dump at a 90° angle for quick unloading.
4. If bagging the grass clippings is desired, the grass can be pulled from the cart at the curve side into a plastic lawn bag. Also, the grass can be dumped onto a tarp for throwing into a trailer.



**TORQUE SPECIFICATIONS FOR  
STANDARD MACHINE HARDWARE  
TOLERANCE ±20%**

SIZE	SAE GRADE #2		SAE GRADE #5		SAE GRADE #8	
	0					
	In./Lbs.		In./Lbs.		In./Lbs.	
	Ft./Lbs.	N m	Ft./Lbs.	Nm.	Ft./Lbs.	Nm.
8-32	19	2.1	30	3.4	41	4.6
8-36	20	2.3	31	3.5	43	4.9
1 0-24	27	3.1	43	4.9	60	6.8
1 0-32	31	3.5	49	5.5	68	7.7
1/4-20	66	7.6	8	10.9	12	16.3
1/4-28	76	8.6	10	13.6	14	19.
5/16-18	11	15.	17	23.1	25	34.
5/16-24	12	16.3	19	25.8	25	34.
3/8-16	20	27.2	30	40.8	45	61.2
3/8-24	23	31.3	35	47.6	50	68.
7/16-14	30	40.8	50	68.	70	95.2
7/16-20	35	47.6	55	74.8	80	108.8
1/2-13	50	68.	75	102.	110	149.6
1/2-20	55	74.8	90	122.4	120	163.2
9/16-12	65	88.4	110	149.6	150	204.
9/16-18	75	102.	120	163.2	170	231.2
5/8-11	90,	122.4	150	204.	220	299.2
5/8-18	100	136.	180	244.8	240	326.4
3/4-10	160	217.6	260	353.6	386	525.
3/4-16	180	244.8	300	408.	420	571.2
7/8-9	140	190.4	400	544.	600	816.
7/8-14	155	210.8	440	598.4	660	897.6
1-8	220	299.2	580	788.8	900	1,224.
1-12	240	326.4	640	870.4	1,000	1,360.

**NOTE:**

1. These torque values are to be used for all hardware excluding: locknuts, self-tapping screws, thread forming screw., sheet metal screws and socket head setscrews.
2. Recommended seating torque values for locknuts:
  - a. For prevailing torque locknuts - use 65% of grade 5 torques.
  - b. For flange whitlock nuts (and screws) - use 135% of grade 5 torques.
3. Unless otherwise noted on assembly drawings all torque values must meet this specification.

**BOLT HEAD MARKING  
S.A.E. GRADE:**

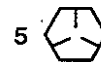
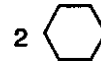

## Free Manuals Download Website

<http://myh66.com>

<http://usermanuals.us>

<http://www.somanuals.com>

<http://www.4manuals.cc>

<http://www.manual-lib.com>

<http://www.404manual.com>

<http://www.luxmanual.com>

<http://aubethermostatmanual.com>

Golf course search by state

<http://golfingnear.com>

Email search by domain

<http://emailbydomain.com>

Auto manuals search

<http://auto.somanuals.com>

TV manuals search

<http://tv.somanuals.com>