

Safety Instruction & Operator's Manual for

# **SNAPPER**<sup>®</sup>



## **EDGER/TRIMMER**

- Specifications
- Operating Instructions
- Maintenance Information

**MODEL  
ET302B**

Thank you for buying a SNAPPER product! Your Edger-Trimmer was designed and built to provide long and satisfactory service. Study this manual carefully before operating this equipment and pay particular attention to the Important Safety Instructions found on page 2. Keep in mind that an Edger-Trimmer, like any other mechanical device, can be potentially dangerous if used improperly. Following the instructions in this and the engine manual will help you continue to enjoy the trouble-free operation expected of a SNAPPER.

**SNAPPER** McDonough, GA., 30253 U.S.A.  
DIVISION OF FUQUA INDUSTRIES, INC.

PN: 022898

# CONTENTS

	Page		Page
<b>General Safety Suggestions</b>	1	<b>Correct Edger-Trimmer Usage</b>	6
		Operation of the Edger-Trimmer	6
<b>Registration and Warranty</b>	Back Page	<b>Maintaining Your Edger-Trimmer</b>	7
<b>Parts List</b>	11	Maintenance Checklist	7
<b>Edger-Trimmer Features</b>	2	Engine	7
<b>Assembly</b>	3	Oil Quality	7
Attaching the Handle	3	Oil Level	7
Installing the Throttle Wire	3	Oil Changes	7
Fill Engine with Oil	3	Air Filter	8
<b>Operating Your Edger-Trimmer</b>	4	Spark Plug	8
Correct Engine Operation	4	Electronic Ignition	8
Throttle/Choke Control	4	Carburetor Adjustment	8-9
Fuel Specification	4	Blade Maintenance	9
Oil Specification	4	Blade Change	9
Starting The Engine	5	Lubrication	9
Engaging Drive Belt	5	Storage Instructions	9
Stopping The Engine	5	<b>Trouble Shooting Checklist</b>	13



## CAUTION



This symbol marks important instructions relating to your personal safety. To avoid the possibility of injury, read and follow such instructions carefully.

When the manual refers to the left or right side of the edger-trimmer, it means your left and right when standing in the operating position.

# GENERAL SAFETY SUGGESTIONS

Recommended by Outdoor Power Equipment Institute

## DO NOT MODIFY EDGER-TRIMMER

Unauthorized modification to the edger-trimmer may impair its function and safety and affect edger-trimmer life.

### Training

1. Read the Operating and Maintenance Instruction Manual carefully. Be thoroughly familiar with the controls and proper use of the equipment.
2. Never allow children to operate edger-trimmer.
3. Keep area of operation clear of all persons, particularly small children and pets.
4. Thoroughly train anyone using the edger-trimmer. Make sure all edger-trimmer operators know the safety, operating and maintenance procedures.

### Preparation

1. Thoroughly inspect the area where edger-trimmer is to be used, and remove all stones, sticks, wire, bones and other foreign objects which might be picked up and thrown.
2. Do not operate edger-trimmer when barefoot or wearing open sandals. Always wear substantial foot wear, and pants or slacks that cover your legs when operating edger-trimmer.
3. Check fuel before starting engine. Do not fill gasoline tank indoors, when engine is running, or while engine is still hot. Clean off any spilled gasoline before starting engine.
4. Disengage cutterhead drive before starting engine.
5. Do not use edger-trimmer unless blade guard, belt guards and debris guard are properly in place.
6. Edge or trim only in daylight or in good artificial light.
7. Never operate equipment in wet grass. Always be sure of your footing. Keep a firm hold on the handle and walk, never run.

### Operation

1. Start the engine carefully. Keep hands and feet well away from blade.
2. Do not change engine governor setting or over-speed engine.
3. Wear safety glasses when operating edger-trimmer.
4. Keep clear of discharge opening at all times. Never direct discharge of any material toward bystanders nor allow anyone near machine while it is in operation.
5. Stop blade when crossing gravel drive, walks or roads.
6. After striking a foreign object, stop the engine and inspect edger-trimmer for damage. Repair damage before starting engine.
7. Avoid loss of control or tipping on slopes and sharp corners by reducing speed.
8. If edger-trimmer should start to vibrate abnormally, stop the engine and check for the cause. Vibration is generally a warning of trouble.
9. Stop the engine whenever you leave the edger-trimmer, and when making repairs or inspections.

10. When repairing or inspecting make certain blade and all moving parts have stopped. Disconnect spark plug wire and keep wire away from plug to prevent accidental starting.
11. Do not run engine indoors.
12. Shut engine off and wait until blade comes to a complete stop before removing grass that may clog blade guard.
13. Watch out for traffic when working near roadways.
14. Stay alert for uneven sidewalks, holes in terrain or other hidden hazards when using edger-trimmer. Always push slowly over rough ground.
15. Remember, never operate edger-trimmer unless blade guard, belt guards and debris guard are properly in place.
16. Disengage power to cutterhead and stop engine before leaving edger-trimmer, before making repairs, inspections or adjustments, and when transporting or not in use.

### Maintenance and Storage

1. Check blade mounting nut frequently for proper tightness.
2. Keep all nuts, bolts and screws tight to be sure equipment is in safe working condition.
3. Never store edger-trimmer with gasoline in the tank in a building where fumes may reach an open flame or spark. Be sure engine has cooled before storing in any enclosure.
4. To reduce fire hazard, keep engine free of grass, leaves or excessive grease.
5. After operating engine, never touch exhaust muffler until it has cooled completely.
6. Keep edger-trimmer in good operating condition and keep safety devices in place.



## TO AVOID INJURY

**READ OPERATOR'S MANUAL • KNOW LOCATION & FUNCTION OF CONTROLS • MAINTAIN SAFETY DEVICES • REMOVE POTENTIAL THROWN OBJECTS • NEVER EDGE OR TRIM NEAR PEOPLE • NEVER CARRY PASSENGERS • LOOK BEFORE BACKING • AVOID SLIPPERY OR STEEP AREAS • STOP BLADE & BACK SLOWLY IF MACHINE STOPS • AVOID BLADE UNLESS BLADE & ENGINE ARE STOPPED.**

# EDGER-TRIMMER FEATURES

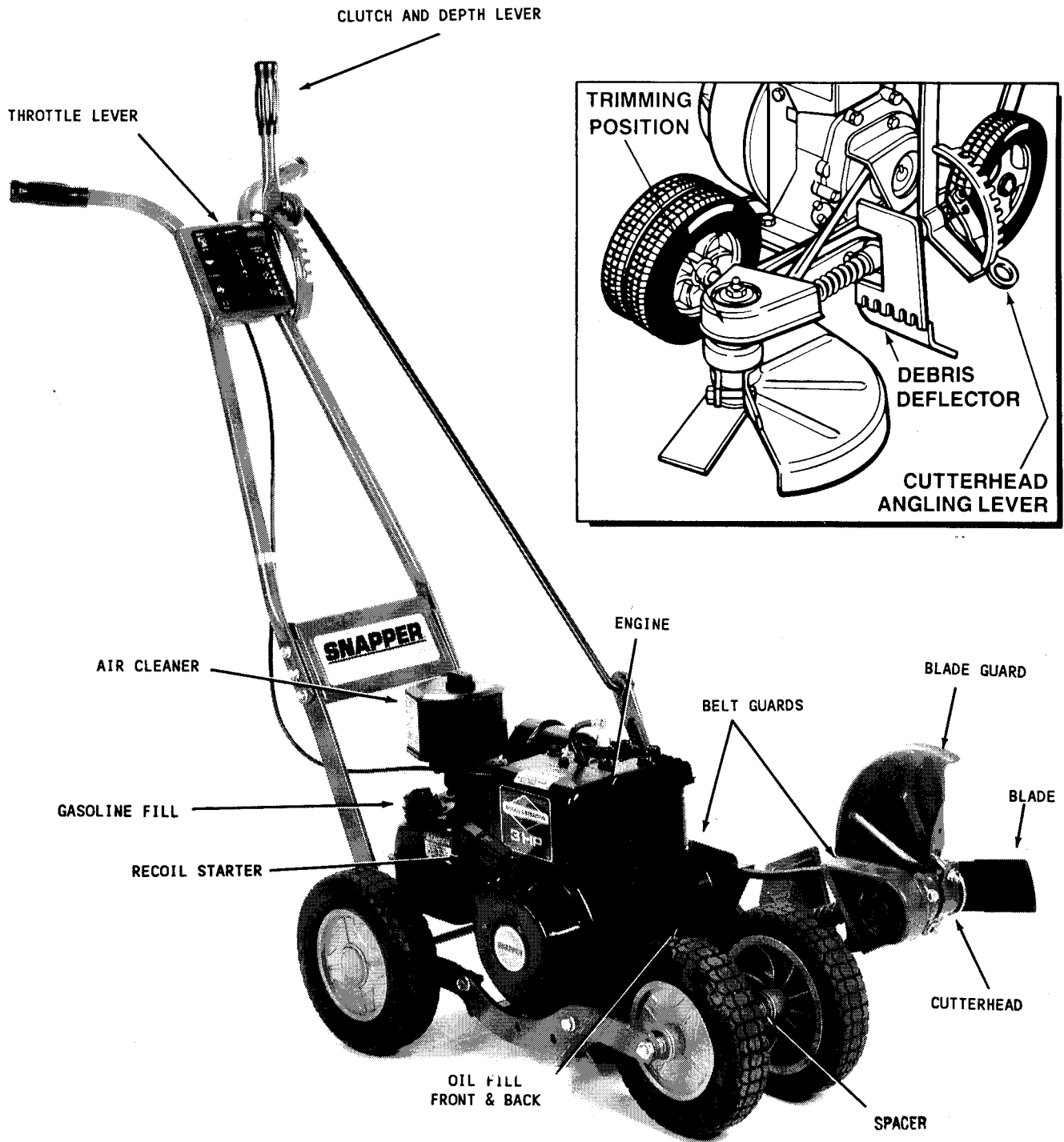

# ASSEMBLY

**TOOLS REQUIRED:** 7/16" Wrench, Pliers, Screwdriver

**NOTE:** Reference to Left or Right side of machine is from the operator's position at the handle, facing forward.

The lawn edger, except the handle and throttle control, is fully assembled, packed and shipped in one container.

## ATTACHING THE HANDLE

1. Remove handle brace, nuts, and bolts. Align the handle, lower support, and handle brace holes. Use all six nuts and bolts. Leave bolts loose until Steps 2 and 3 are completed (Fig. 1).
2. Install control rod into upper and lower pivot bearings and secure with cotter pins (Fig. 1). Oil pivots lightly before installing rod.
3. Move clutch-depth lever into rear notch of quadrant on handlebars. Move cutterhead angling lever to top notch of quadrant.
4. Remove spark plug wire from spark plug. Move throttle to **OFF** position. Check clutch operation by pulling recoil starter rope. If blade turns when depth lever is in top notch, loosen handle bolts and pull towards operator. Snug bolts and check clutch operation again.

### — IMPORTANT NOTE —

Make sure blade does not turn when lever is in top notch — disengaged.

Tighten bolts.

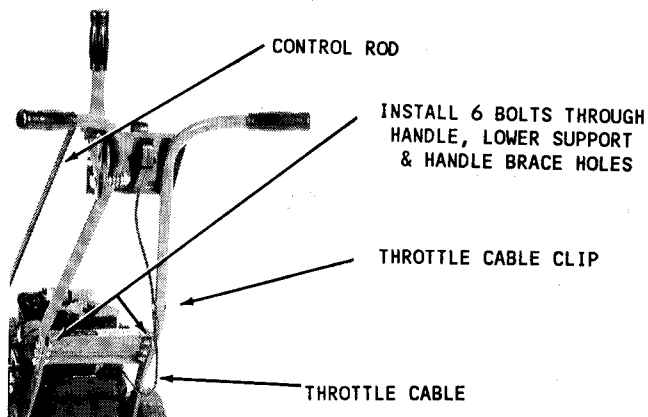

FIG. 1

## FILL ENGINE WITH OIL

Remove oil filler cap and fill engine with 1 1/4 pint/ 20 oz. (.59 L) of API Service SC, SD, SE or SF oil. Choose temperature viscosity from chart in "Maintenance" Section of this manual.

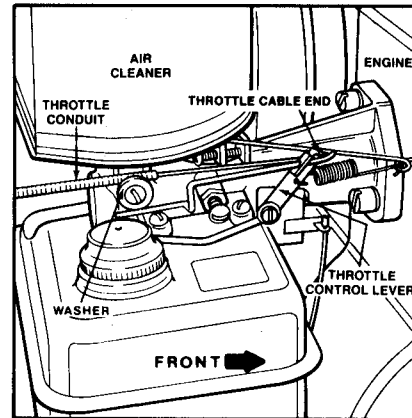

FIG. 2

## INSTALLING THE THROTTLE WIRE

1. Remove thumb screw on top of air cleaner and remove air cleaner from carburetor (Fig. 2).
2. Route throttle cable conduit below spacer panel between frame uprights. (From inner side, toward engine) (Fig. 1).
3. Place throttle cable end through throttle control lever (Fig. 2).

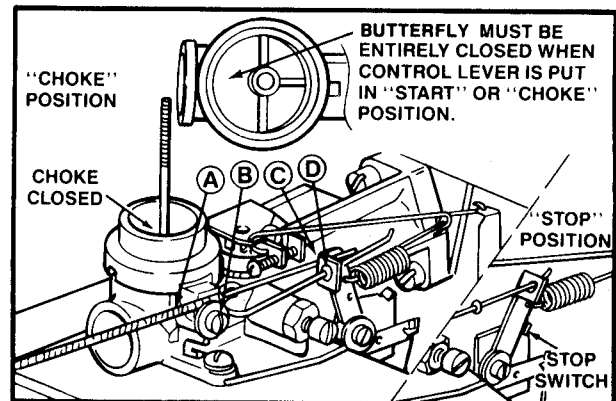

FIG. 3

4. TO ADJUST (Fig. 3). Place throttle/choke control lever on handle in "fast" position. Loosen control casing clamp screw (B) on carburetor. Move control casing (A) and wire forward or backward until speed lever (C) just touches the choke operating link at (D). Tighten casing clamp screw (B) on carburetor. Recheck operation of controls after adjustment (Fig. 3).
5. Replace air cleaner.
6. Clip for the throttle cable should secure cable to handle (Fig. 1).
7. Soak grips in warm water then place on end of handle (Fig. 1).

### — IMPORTANT NOTE —

Read thoroughly and become familiar with the operating, maintenance and usage sections of this manual before attempting to start the edger-trimmer.

# OPERATING YOUR EDGER-TRIMMER

## CORRECT ENGINE OPERATION

### ⚠ CAUTION ⚠

Before starting engine, become familiar with all controls. Read this Operator's Manual thoroughly. Always check engine oil level before starting engine.

### ⚠ WARNING ⚠

Care should be taken to avoid inhaling exhaust gases as they contain carbon monoxide gas which is colorless and odorless. Carbon monoxide is a dangerous gas that can cause unconsciousness and is potentially lethal. Do not run engine in confined areas such as a closed garage.

### ⚠ CAUTION ⚠

Always disengage edger-trimmer blade and shut engine off when leaving the edger-trimmer unattended, even if for just a few minutes. Prevent accidents; don't give children or unauthorized persons an opportunity to operate this machine.

## THROTTLE/CHOKE CONTROL

The throttle/choke control regulates the speed of the engine as measured in RPM (Revolutions Per Minute). This control should not be used to regulate the blade speed of the edger-trimmer.

The engine in your edger-trimmer has been designed with a special governor that limits engine RPM. Unlike an automobile, this governor allows the engine to operate most efficiently at a set speed and protects it from damage caused by excessive RPM. Always operate the edger-trimmer with the throttle control set at 1/2 to full speed as applicable.

The choke control activates a "butterfly" valve in the carburetor. When the choke is partially or completely closed, less air is admitted to the engine. This results in a higher fuel-to-air (richer) mixture that is easier to ignite when the engine is cold. Choking the engine is required when the engine is started cold. Warm engines may not need choking.

## FUEL SPECIFICATION

When the edger-trimmer requires refueling, fill the tank with a good grade (85 octane minimum) of regular gasoline. Leaded or unleaded regular may be used. Do not intermix regular and unleaded gasolines. Do not mix oil with gasoline. The use of gasohol fuel is not recommended by Briggs & Stratton.

In general, the use of unleaded fuel will reduce the buildup of combustion deposits in the engine and contributes to long valve life. It is suggested that leaded regular gasoline be used for the first 25 hours of operation, while the piston rings are seating, and unleaded fuel thereafter.

### ⚠ CAUTION ⚠

Handle fuel with care — it is highly flammable. Use only approved fuel container. Never add fuel while engine is running. Fill fuel tank outdoors with extreme care. Never fill fuel tank indoors. Replace gasoline cap securely and wipe up all spilled fuel.

Always clean area around fuel cap before removing it to prevent excessive amounts of dirt from entering fuel system. Also insure that fuel storage container you are using is clean and in good condition.

## OIL SPECIFICATION

To protect your edger-trimmer engine, check the engine oil level before each use. Complete information concerning recommended oils and how to check the oil level is given in the "Maintaining Your Edger-Trimmer" section of this manual.

Check oil level of engine every time edger-trimmer is used. An improper oil level can cause extensive internal damage to engine.

### ⚠ CAUTION ⚠

Always start edger-trimmer in motion slowly. Sudden starts can be damaging to the equipment and could cause loss of operator control.

### ⚠ CAUTION ⚠

Rotating blade can throw dirt or debris. Wear safety glasses when operating the edger-trimmer.

## ADJUSTING CUTTERHEAD ANGLE

Before starting engine adjust cutterhead angle. The cutterhead angling lever, located on the left hand side of the frame, enables the operator to position the blade horizontally for trimming or choose several vertical positions for edging.

### ⚠ WARNING ⚠

Never adjust cutterhead angle when engine is running.

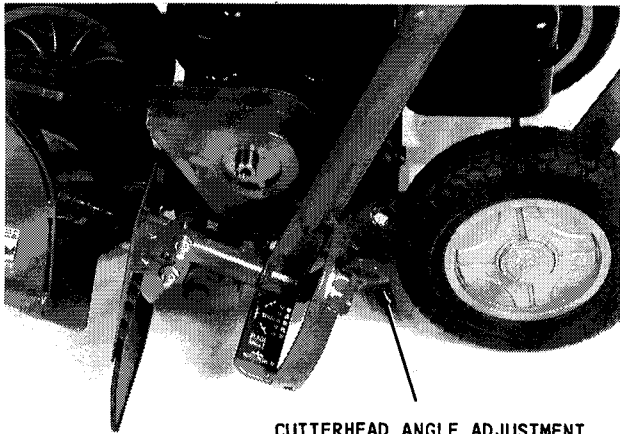

CUTTERHEAD ANGLE ADJUSTMENT

**Cutterhead Angle Adjustment**

**CLUTCH AND DEPTH LEVER SETTINGS**

Clutch and Depth lever is used to engage and disengage the drive belt which operates the blade. It is also used to regulate the depth of edging and height of trimming.

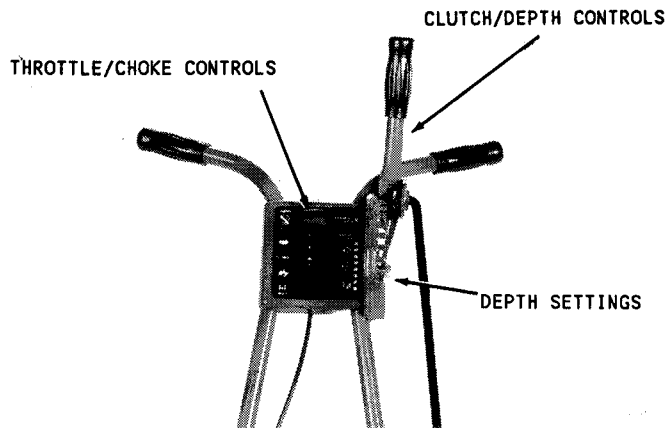

**Throttle/Choke and Clutch/Depth Controls.**

**STARTING THE ENGINE**

Be sure the clutch lever is in the rear DISENGAGED position before starting engine.

Move throttle control lever all the way forward to the Choke position.

Grasp the recoil starting handle and pull quickly. Return the handle slowly. If the engine fails to start after three or four pulls, lower the throttle to the detented full throttle (Fast) position.

Once the engine starts, raise the throttle to the detented full throttle (Fast) position. Use SLOW position to idle the engine.

**ENGAGING DRIVE BELT**

Move Clutch and Depth lever forward to engage drive belt and blade. Notches in base of lever permit adjusting depth of cut for edging and height of trimming.

**TO STOP**

Disengage edger-trimmer clutch and depth lever.

Move throttle/choke control to stop position. Make sure engine is stopped and blade is not rotating before leaving the operating position.

**WHEEL POSITIONING**

The wheel adjusting spacer should be centered between the wheels when edging in the vertical position. Wheels must be in the dual position to the right when edging with cutterhead in an angle position or trimming (horizontal position).

**⚠ WARNING ⚠**

**Do not change wheel positions when engine is running.**

Remove the spacer from between the wheels by lifting on spacer with open side down. Slide the left front wheel on the axle toward the right wheel and once again install the spacer on the axle between the frame and wheel.

**⚠ CAUTION ⚠**

**Before starting the engine be sure the wheels and cutterhead are positioned so the blade will not strike the wheels.**

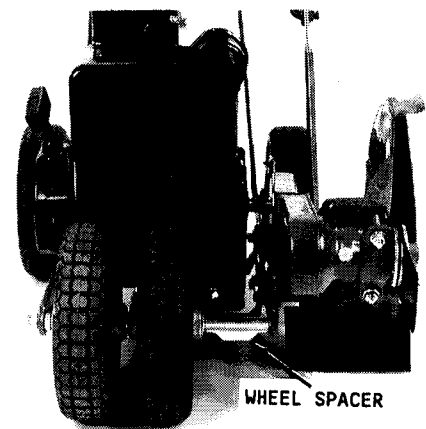

WHEEL SPACER

POSITIONED FOR TRIMMING

**Wheel Positioning**

# CORRECT EDGER-TRIMMER USAGE

## ⚠ CAUTION ⚠

Read all manuals provided before operating. These manuals give a detailed description of operation and point out other areas of caution. Familiarize yourself thoroughly with equipment before attempting to use it.

## OPERATION OF THE EDGER-TRIMMER

## ⚠ WARNING ⚠

Keep all shields in place. Never attempt to clear discharge areas or edger-trimmer blade without disengaging the edger-trimmer and stopping the engine.

Your edger-trimmer is designed to give a professionally groomed appearance to your lawn with minimum effort. It will edge lawns at walks, around flower beds, trim close to poles and hydrants, also under fences and other hard to reach locations. For best appearance around flowers adjust blade to 20° angle cut.

For best results adjust the cutting depth of the blade to within ½" to 1" deep (with a new blade usually in the third notch of the adjustment bracket at handle).

Too deep a cut will put unnecessary stress on engine and accelerate blade wear. Cutting too shallow allows rapid regrowth of roots.

Make sure to re-adjust cutting depth as blade begins to wear at tips.

Avoid edging or trimming in wet grass as it may clog up in the blade guard and cause splattering. The general appearance will be much better when grass is dry.

Always push edger-trimmer at moderate walking speed — at this speed your edger-trimmer is designed to cut more than 100 ft. per minute. Four wheel design of edger-trimmer permits easy and stable edging, riding securely on sidewalk or cement surfaces.

Around specially shaped flower beds or curved sections follow these simple steps: It will be easier to cut around corners when front wheels are placed together at right side of trimmer-edger. Before starting engine remove wheel spacer clip on front axle, slide wheels to side away from blade and replace spacer.

After starting engine, set blade depth and by slightly lifting rear wheels, guide edger-trimmer around corners and odd angles.

## WARNING TO PURCHASERS OF INTERNAL COMBUSTION ENGINE EQUIPPED MACHINERY OR DEVICES

This equipment does not include a spark arrestor muffler.

If this equipment is used on any forest-covered land, brush-covered land or grass-covered land in the State of California, the law requires that a spark arrestor be installed and in effective working order before using this equipment on such land. The spark arrestor must be attached to the exhaust system and comply with Section 4442 of the California Public Resources Code.

If this equipment is used in a state or national park or campground, a U.S.D.A. Forestry Department approved spark arrestor muffler must be utilized.



# MAINTAINING YOUR EDGER-TRIMMER

## ⚠ CAUTION ⚠

To minimize the chance of injury, perform all maintenance and adjustments on your edger-trimmer with engine off unless instructed otherwise in this section. Use extreme care when working near operating machinery. Do not wear loose fitting clothing. Remove watch and jewelry before beginning work and observe common safety practices when using tools.

Check the oil level of the engine every time the edger-trimmer is used. An improper oil level can cause extensive internal damage to engine.

To check the engine oil level, stop edger-trimmer where the engine is level. Shut off the engine and remove the spark plug wire from the spark plug.

Remove the oil filler plug on the back or front side of the engine block by turning the cap counterclockwise. The oil level should be to the top of the oil fill cap. Add oil as necessary. Be sure to add the same viscosity oil as is presently in the engine.

## MAINTENANCE CHECKLIST

	Before Each Use	After Each Use	Every 25 Hours	Every 50 Hours	Every 100 Hours
<b>SERVICE OPERATION</b>					
Check:					
Engine Oil Level	X				
Tightness of all Attaching Hardware			X		
Clean Engine Cooling Fins		X			
Clean Air Filter			X		
Lubricate			X		
Change Engine Oil(1)			X		
Inspect Spark Plug				X	
Replace Spark Plug					X
Replace Air Filter					X
Grease Cutter Head			X		

(1) Refer to text for initial service interval for new edger-trimmer.

**NOTE:** These service intervals are considered **MAXIMUM** under normal operating conditions. Increase frequency under extremely dirty or dusty conditions.

## GASOLINE ENGINE

### Oil Quality

For maximum engine protection under all operating conditions use API Service Classification SC, SD, SE, or SF oil. These letters may appear on oil can singularly or in combination with other letters.

### Oil Level

Form a habit of checking oil level regularly.

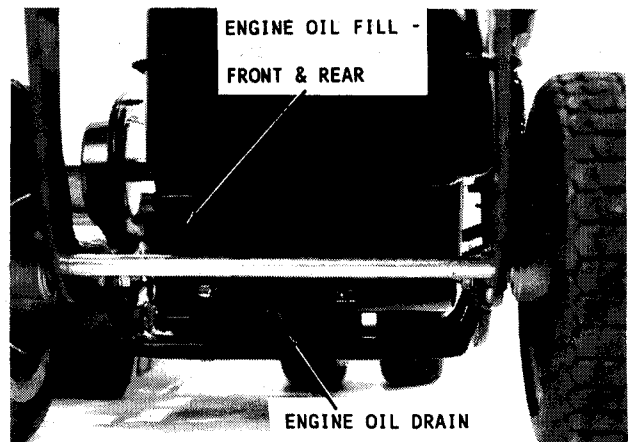

Engine Oil Drain and Fill Plug

### Oil Changes

The engine oil in your edger-trimmer should be changed after the first 2 hours of operation. Thereafter, the oil should be changed at 25 operating hour intervals. If operating conditions are extremely dusty or dirty the frequency of oil changes should be increased.

**Failure to change engine oil at recommended intervals can lead to serious damage to engine. This is especially true when using detergent oils which are designed to hold impurities in suspension; when saturation point is reached, oil may suddenly break down to form a gelatin-like substance which seriously impairs and can even stop flow of oil. Increase frequency of oil changes if edger-trimmer is operated under extremely dusty conditions.**

Before changing the oil, start the engine and allow it to warm up. This will allow the oil to flow more freely. Shut off the engine and remove the spark plug wire from the spark plug.

Remove the engine oil drain plug and drain all engine oil into a suitable container. Replace the drain plug.

Remove oil filler cap and add about 80% of amount of oil specified in following chart. Also shown are charts for selecting correct oil type and oil viscosity. When using temperature — viscosity chart, select air temperature most likely to be encountered within next 25 hours of operation.

#### ENGINE OIL TEMPERATURE — VISCOSITY CHART

Air Temperature	Oil Viscosity
Above 40°F (4°C)	SAE 30
0° to 100°F (-18° to 38°C)	SAE 10W-30, 10W-40
Below 20°F (-6°C)	SAE 5W-20, 5W-30*

\*If not available, a synthetic oil with a viscosity of 5W-20, 5W-30 or 5W-40 may be used.

#### ENGINE OIL TYPE

API Service, SC, SD, SE, or SF  
Oil Capacity 1¼ Pint/20 oz. (.59 L)

After adding 80% of prescribed amount of oil, check oil level. Add oil as necessary to bring oil to "Full" level.

#### Air Filter

Dirt induced through improperly installed, poorly serviced, or inadequate air filter cartridge, is more often cause of a worn out engine than long hours of operation. A small amount of dirt will destroy a set of piston rings in a matter of hours. A clogged cartridge causes a richer fuel mixture which wastes gasoline, and may lead to forming harmful sludge deposits.

Clean engine air filter after every 25 hours of operation (more often if edger-trimmer is operated under extremely dusty conditions).

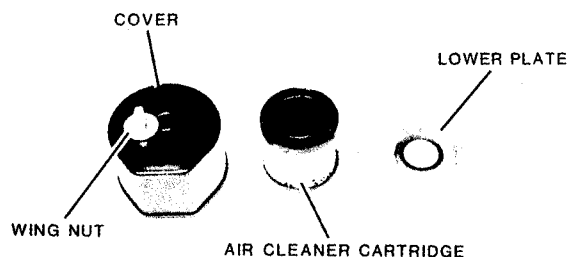

#### Air Filter Assembly

Remove cartridge and clean air cleaner cover carefully to prevent dirt from entering carburetor.

Clean cartridge by tapping gently on flat surface.

- If very dirty, replace cartridge or wash in a low or non-sudsing detergent and warm water solution.
- Rinse thoroughly from INSIDE OUT until water is clear.
- Cartridge must be allowed to stand and air dry thoroughly before using.

Reassemble air cleaner.

### ⚠ CAUTION ⚠

Petroleum solvents such as kerosene are not to be used to clean cartridge. They may cause deterioration of the cartridge. **DO NOT OIL CARTRIDGE. DO NOT USE PRESSURIZED AIR TO CLEAN OR DRY CARTRIDGE.**

Replace filter cartridges at 100 hour intervals, or once a year, whichever comes first. As with cleaning the filter, replacement intervals must be shortened when operating under extremely dusty conditions. To protect your engine, use only the manufacturer's replacement filter, or replacement filters with equivalent specifications.

Check following when installing a new or serviced element:

- Lower plate must be securely tightened to carburetor. Replace lower plate if bent or cracked.
- Gasket surfaces of cartridge must be flat against lower plate and cover to seal effectively.
- Tighten wing nut securely.
- Be sure cover seals and gaskets, where used, are in good condition and will seal properly. Bad gaskets and seals can let unfiltered air into carburetor.

**To prevent any dirt or other contaminants from entering engine, always cover carburetor air horn when air cleaner is removed.**

#### Spark Plug

Engine misfire, or generally poor operation, is often caused by spark plug in poor condition or with incorrect spark gap setting. Spark plug should be checked after each 50 hours of operation. Replace a spark plug at 100 operating hour intervals, or sooner if inspection reveals fouling or excessive deterioration.

Always clean area around spark plug before removing it to prevent dirt from entering engine. Use a spark plug wrench to remove and install plug.

Check condition of plug. Good operating conditions are indicated by a light coating of gray or tan deposit. A dead white, blistered coating could indicate engine overheating. A black coating could indicate an "overrich" fuel mixture caused by a clogged air cleaner, or improper carburetor adjustment.

Replace spark plug that is not in good condition. **Never sandblast, wire brush, scrape or reinstall spark plug in poor condition. Best results are obtained with a new plug.**

Always check the spark plug gap before installing a new plug or reinstalling the original plug. Use a spark plug gap gauge to adjust the electrode air gap to .030 in. (.8 mm).

#### Electronic Ignition

The breakerless electronic ignition system requires no periodic maintenance.

#### Carburetor Adjustment

Carburetor is adjusted at factory and should not have to be reset. If a condition is noted as outlined in following "Carburetor Adjustment Chart", carburetor should be readjusted immediately. Continued opera-

tion with incorrect carburetor settings can lead to a fouled spark plug, overheating, excessive valve wear or other problems. If black exhaust smoke is noted, check air cleaner first — an "overrich" mixture is usually caused by a poorly serviced, clogged air cleaner element, not an improperly adjusted carburetor.

---

#### CONDITION

---

- A. Black, sooty exhaust smoke, engine sluggish.
- B. Engine misses and backfires at high speed.
- C. Engine starts, sputters and dies under cold weather starting.
- D. Engine runs rough or stalls at idle speed.

---

#### POSSIBLE CAUSE/PROBABLE REMEDY

---

- A. Mixture too rich — readjust main fuel needle.
- B. Mixture too lean — readjust main fuel needle.
- C. Mixture too lean — readjust main fuel needle.
- D. Idle speed too low or improper idle adjustment — readjust speed then idle adjustment screw if needed.

---

#### Carburetor Adjustment Chart

Correct carburetor adjustment requires a significant amount of knowledge as well as special equipment, such as a good tachometer. In addition, other adjustments, such as governor settings, may also be necessary after adjusting the carburetor. For these reasons, it is suggested that carburetor adjustments be performed by an authorized dealer.

## BLADE MAINTENANCE

**⚠ CAUTION ⚠**

Sharp edges of edger-trimmer blade can cut you during blade maintenance or adjustment. Use suitable covering over cutting edges of blade to prevent bodily harm.

## BLADE CHANGE

1. Place a 5/16" Allen wrench on the inside of cutterhead shaft and a 3/4" wrench on the blade nut, turn to loosen nut. Remove outer washer and old blade.
2. Replace blade with only McLane blade (available in 3-pack). Place outer washer the same direction as removed and tighten nut as snug as possible.

## LUBRICATION

1. The cutter head body needs occasional greasing. Use #2 multi-purpose grease.
2. The cutter head mandrel has two precision sealed bearings that do not need lubrication.

## LUBRICATION

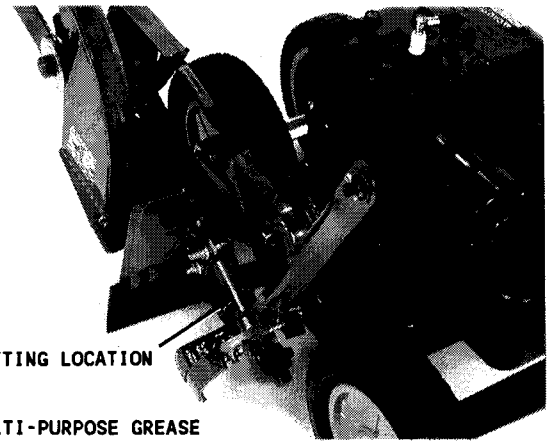

GREASE FITTING LOCATION

USE #2 MULTI-PURPOSE GREASE

#### Cutting Head Lubrication Points

Oil all exposed bearings, linkage and front wheels.

## STORAGE INSTRUCTIONS

Edger-trimmers stored for any length of time should be completely drained of fuel to prevent gum deposits forming on essential parts such as the carburetor and fuel tank. Such deposits may affect the operation of the engine when used again. Therefore, it is important that the following instructions be adhered to before storing the engine.

1. Drain the fuel tank completely.
2. Operate the engine until it stops from lack of fuel to clean all gasoline out of the carburetor.
3. While the engine is still warm, drain the crankcase. Refill with fresh oil.
4. Remove spark plug, pour one ounce of oil into the cylinder. Pull starter rope on the engine to spread the oil. Replace the spark plug.
5. Clean dirt and chaff from cylinder and cylinder head fins, blower housing, etc.

# Lawn Edger and Trimmer Parts Illustration

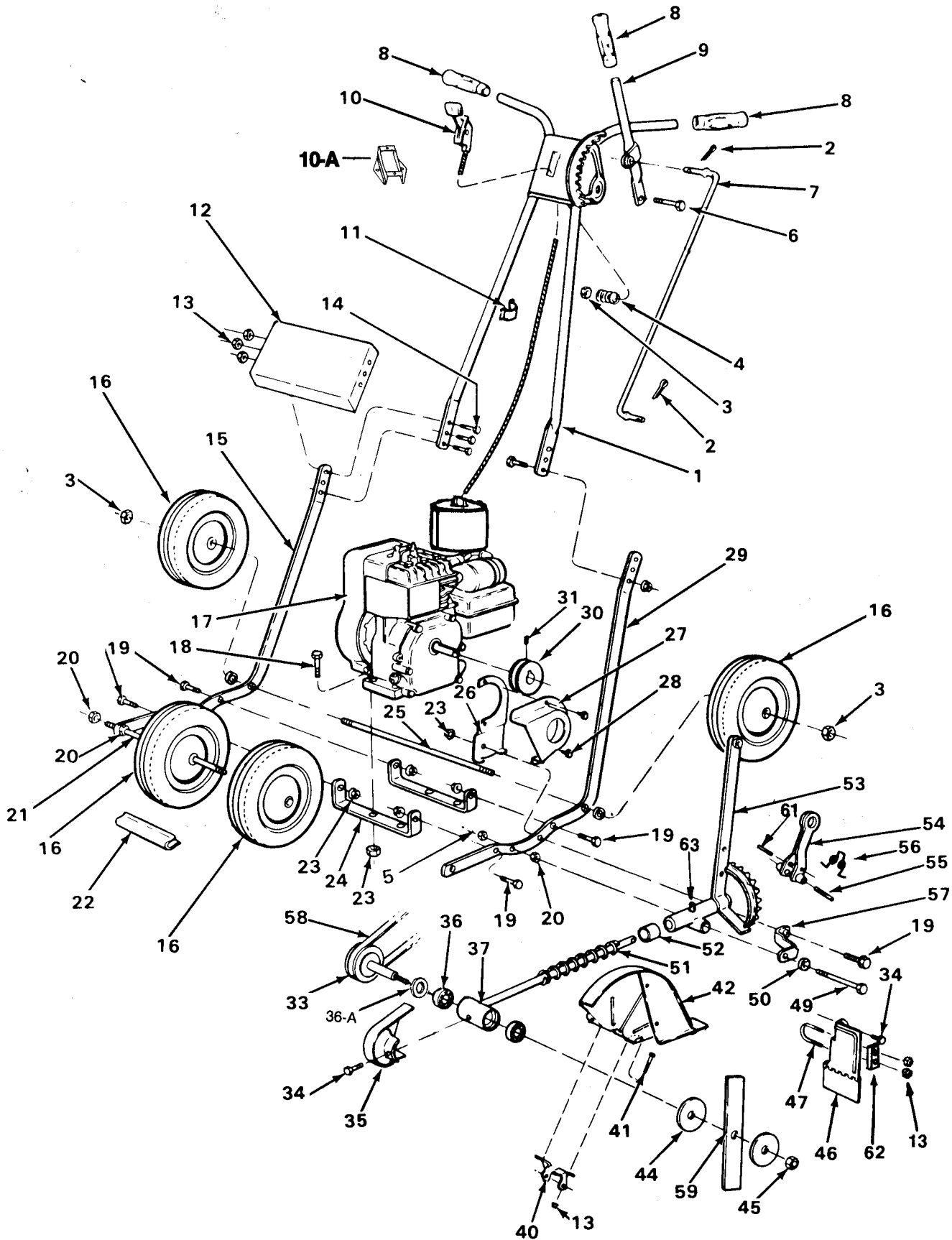

## LAWN EDGER AND TRIMMER PARTS LIST

REF. NO.	PART NO.	DESCRIPTION	REF. NO.	PART NO.	DESCRIPTION
1	041155	Edger Handle	41	041192	Bolt, Hex 1/4-28 x 1-1/2
2	041156	Cotter Pin, 1/8 x 3/4	42	041193	Blade Guard Main
3	041157	Nut Lock Hex 7/16-14 x 2	42	041231	Blade Guard Complete (SVC)
4	041158	Spring	44	041194	Washer, Friction
6	041159	Bolt, Hex, 7/16-14 x 2	45	041195	Nut 1/2-20
7	041160	Rod, Clutch & Depth	46	041196	Deflector, Debris Shield
8	041161	Handle Grip	47	041197	U-Clamp
9	041162	Lever, Clutch & Depth	47	041217	Service, Debris Guard Complete
10	041163	Throttle Control (Homeowner)	49	041198	Pivot Bolt
10A	041218	Throttle Control Holder	50	041199	Flat Washer 7/16
11	041164	Clip, Throttle Cable	51	041200	Spring Head Recoil
12	041165	Handle Cross Brace w/Snapper Decal 24386 (Homeowner)	52	041201	Cup
13	041166	Nut, Hex 1/4-28	53	041202	Body, Cutterhead
14	041167	Bolt, Hex 1/4-28 x 7/8	55	041203	Lever, Angle Shifting
15	041168	8" Frame, Right Hand	55	041204	Pin, 5/16 x 1-1/2
16	042131	8" Plastic Wheel	56	041205	Spring, Lever Rod
17	041229	Engine, 3HP Briggs & Stratton w/Snapper Decal	57	041206	Brace, Cutterhead
18	041172	Bolt, 5/16-24 x 1-1/2	58	041207	Drive Belt
19	041173	Bolt 5/16-24 x 7/8	59	041211	Cutting Blade (P.O.P. Package)
20		Nut, Hex 7/16-14	61	041208	Pin, 5/16 x 1-1/4
21	041175	8" Front Axle	62	041209	U-Clamp Spacer
22	041176	8" Front Wheel Spacer (4 1/4)	63	041210	Grease Fitting
22	041230	8" Front Wheel Spacer		041170	Rear Wheel Hub Cap (Plastic Wheel)
23	041177	Nut, Hex 5/16-24		041213	Bearing, R-O Wheel
24	041178	8" Frame Crossmember		041214	Bearing, R-O/Front Wheel
25	041179	8" Rear Axle		041215	Service, Rear Wheel Complete
26	041180	Bracket, Engine Pulley Guard		041216	Service, Front Wheel Complete
27	041181	Guard, Engine Pulley		041219	Pulley Guard/Bracket Assembly Service
28	041182	Screw, #10 x 1/2		041220	Cutting Head Service Assembly
29	041183	8" Frame, Left Hand		041222	Bearing, Handle
30	042132	Engine Pulley (B&S)		041223	8" Tire Only
31	041185	Set Screw, 5/16-24 x 5/16		041224	8" Rear Rim Only
33	041186	SVC, Cutter Head/Shaft Complete		041225	8" Front Rim Only
34	041187	Screw, Hex 1/4-20 x 1/2			
35	041188	Cutterhead Pulley Guard			
36	041189	Cutterhead Bearing			
36A	041221	Spring Washer			
37	041190	Mandrel Head			
40	041191	Clamp, Blade Guard			

# NOTES — MAINTENANCE RECORD

---

# TROUBLE SHOOTING CHART

## PROBLEM

## CAUSE

<b>1</b> Engine fails to start.	<b>A</b> Check fuel tank for gas. <b>B</b> Spark plug lead wire disconnected. <b>C</b> Throttle control lever not in starting position. <b>D</b> Check spark plug.* <b>E</b> Carburetor improperly adjusted. Engine flooded. Remove spark plug, dry the plug, crank engine with plug removed, and throttle in off position. Replace spark plug and lead wire and resume starting procedures. <b>F</b> Old/stale gas. Drain and refill with fresh gas.
<b>2</b> Hard starting or loss of power.	<b>A</b> Spark plug wire loose. <b>B</b> Carburetor improperly adjusted.* <b>C</b> Dirty air cleaner.*
<b>3</b> Operation erratic.	<b>A</b> Dirt in gas tank. Drain, clean and refill. <b>B</b> Dirty air cleaner.* <b>C</b> Water in fuel supply. Drain and refill. <b>D</b> Vent in gas cap and/or carburetor plugged. Clear vent. <b>E</b> Carburetor improperly adjusted.*
<b>4</b> Occasional skip (hesitates) at high speed.	<b>A</b> Spark plug fouled, faulty or gap too wide.* <b>B</b> Carburetor improperly adjusted.* <b>C</b> Dirty air cleaner.*
<b>5</b> Idles poorly.	<b>A</b> Carburetor idle speed too slow.* <b>B</b> Spark plug gap too close.* <b>C</b> Carburetor idle mixture adjustment improperly set.*
<b>6</b> Engine overheats.	<b>A</b> Adjust carburetor.* <b>C</b> Remove any obstructions from air passages in shrouds. <b>B</b> Clean cooling fins. <b>D</b> Fill crankcase to proper oil level.

**\*Note:** For repairs beyond the minor adjustments listed above, please contact your local Lawn Mower Service Shop.

For Engine Service see Authorized Briggs & Stratton Service Center

Refer to the Briggs & Stratton Engine Manual enclosed.

# **SNAPPER.**

## **EDGER-TRIMMERS**

### **ACCESSORY**

Your Edger-Trimmer can be converted to an even more versatile edging and trimming tool with the addition of the optional Curbing Kit. Contact your **SNAPPER** Dealer for complete information on this kit.

#### **MANUFACTURER'S 2-YEAR LIMITED WARRANTY**

For two (2) years from purchase date for the original purchaser's residential, non-commercial use [ninety (90) days from date for the original purchaser's commercial, rental, or other non-residential use]. SNAPPER, through any SNAPPER dealer, will replace free of charge any part or parts found upon examination by the factory at McDonough, Georgia to be defective in material or workmanship or both.

All transportation cost incurred by the purchaser in submitting material to a SNAPPER dealer for replacement under this warranty must be borne by the purchaser.

This warranty does not apply to engines and their components, as these items are warranted separately by their manufacturers, and does not apply to batteries which are covered separately.

This warranty does not apply to parts that have been damaged by accident, alteration, abuse, lubrication, normal wear, or other cause beyond our control. There is no other express warranty.

Implied warranties, including those of merchantability and fitness for a particular purpose, are limited to two (2) years from purchase date for the original purchaser's residential, non-commercial use [ninety (90) days from purchase for the original purchaser's commercial, retail or other non-residential use], and to the extent permitted by law, any and all implied warranties are excluded. This is the exclusive remedy. Liabilities for consequential damages under any and all warranties are excluded.

Some states do not allow limitations on how long an implied warranty lasts, or do not allow the exclusion or limitation of incidental or consequential damages, so the above limitation may not apply to you. This warranty gives you specific legal rights, and you may also have other rights which vary from state to state.

**WARNING: THE USE OF REPLACEMENT PARTS OTHER THAN GENUINE SNAPPER PARTS MAY IMPAIR THE SAFETY OF SNAPPER PRODUCTS AND WILL VOID ANY LIABILITY AND WARRANTY BY SNAPPER ASSOCIATED WITH THE USE OF SUCH PARTS.**

**IMPORTANT:** Please fill out the attached SNAPPER Product Registration Card immediately and mail to: SNAPPER, McDONOUGH, GEORGIA 30253

**SNAPPER** • McDonough, GA., 30253 U.S.A.  
DIVISION OF FUQUA INDUSTRIES, INC.



## Free Manuals Download Website

<http://myh66.com>

<http://usermanuals.us>

<http://www.somanuals.com>

<http://www.4manuals.cc>

<http://www.manual-lib.com>

<http://www.404manual.com>

<http://www.luxmanual.com>

<http://aubethermostatmanual.com>

Golf course search by state

<http://golfingnear.com>

Email search by domain

<http://emailbydomain.com>

Auto manuals search

<http://auto.somanuals.com>

TV manuals search

<http://tv.somanuals.com>