

for

SNAPPER® GARDEN TRACTOR

42" #8-0199
48" #8-0299
54" #8-0499

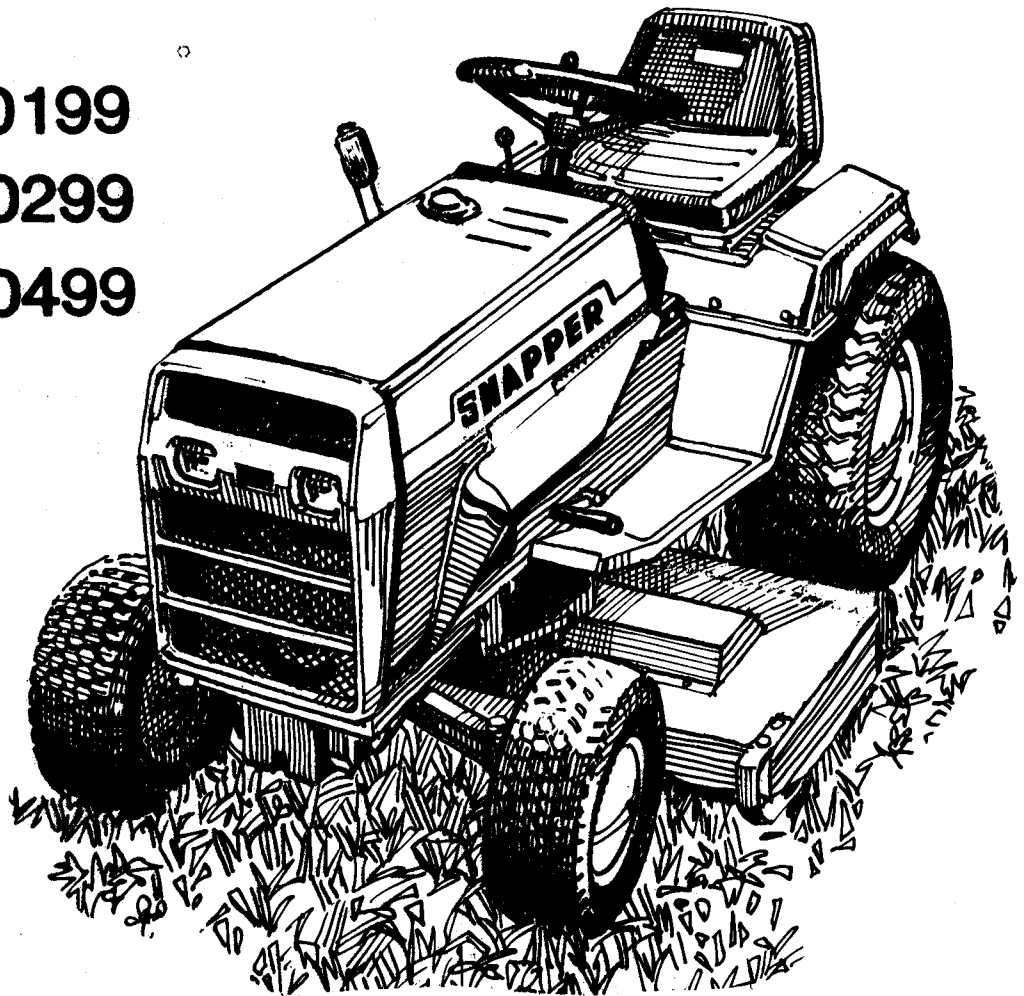

MOWER ATTACHMENTS

IT IS THE POLICY OF SNAPPER POWER EQUIPMENT TO IMPROVE ITS PRODUCTS WHENEVER IT IS POSSIBLE AND PRACTICAL TO DO SO. WE RESERVE THE RIGHT TO MAKE CHANGES OR ADD IMPROVEMENTS AT ANY TIME WITHOUT INCURRING ANY OBLIGATION TO MAKE SUCH CHANGES ON PRODUCTS MANUFACTURED PREVIOUSLY.

INDEX - MAIN COMPONENTS

DESCRIPTION	PAGE(s)	42 MOWER	48 MOWER	54 MOWER
ADJUSTER, Timing Belt		4-5	6-7	10-11
BEARINGS, Spindle		4-5	6-7	10-11
BELTS, Mower Drive		4-5	6-7	10-11
BLADES, Cutting		4-5	6-7	10-11
BRACKETS, Mid-Mount		14	14	14
BRACKET, Belt Adjuster		4-5	6-7	10-11
COVERS, Deck Housing		4-5	6-7	10-11
CHUTE, Side (Deflector)		4-5	6-7	10-11
DECALS, Mower Deck		14	14	14
DECK, Cutting (Mower Housing)		4-5	6-7	10-11
DEFLECTOR, Discharge (Side Chute)		4-5	6-7	10-11
DRIVE, Mower "Mule"		3	3	(NOT USED)
GAUGE-WHEELS		8	8	8
GEAR BOX		(NOT USED)	(NOT USED)	12-13
HOUSING, Mower (Deck)		4-5	6-7	10-11
LINKS, Mower Lift		9	9	9
PINS, Blade Shear		4-5	6-7	10-11
PULLEY, Drive Belt		4-5	6-7	(NOT USED)
PULLEYS, Timing Belt		4-5	6-7	10-11
PULLEY, Mule Drive Idler		3	3	(NOT USED)
SPINDLES, Blade		4-5	6-7	10-11
UNIVERSAL(U) JOINT		(NOT USED)	(NOT USED)	12-13

42 & 48" MOWER (Mule) DRIVE

NOTE: Furnished with 42 & 48" Mowers
and available as accessory kit 6-0458

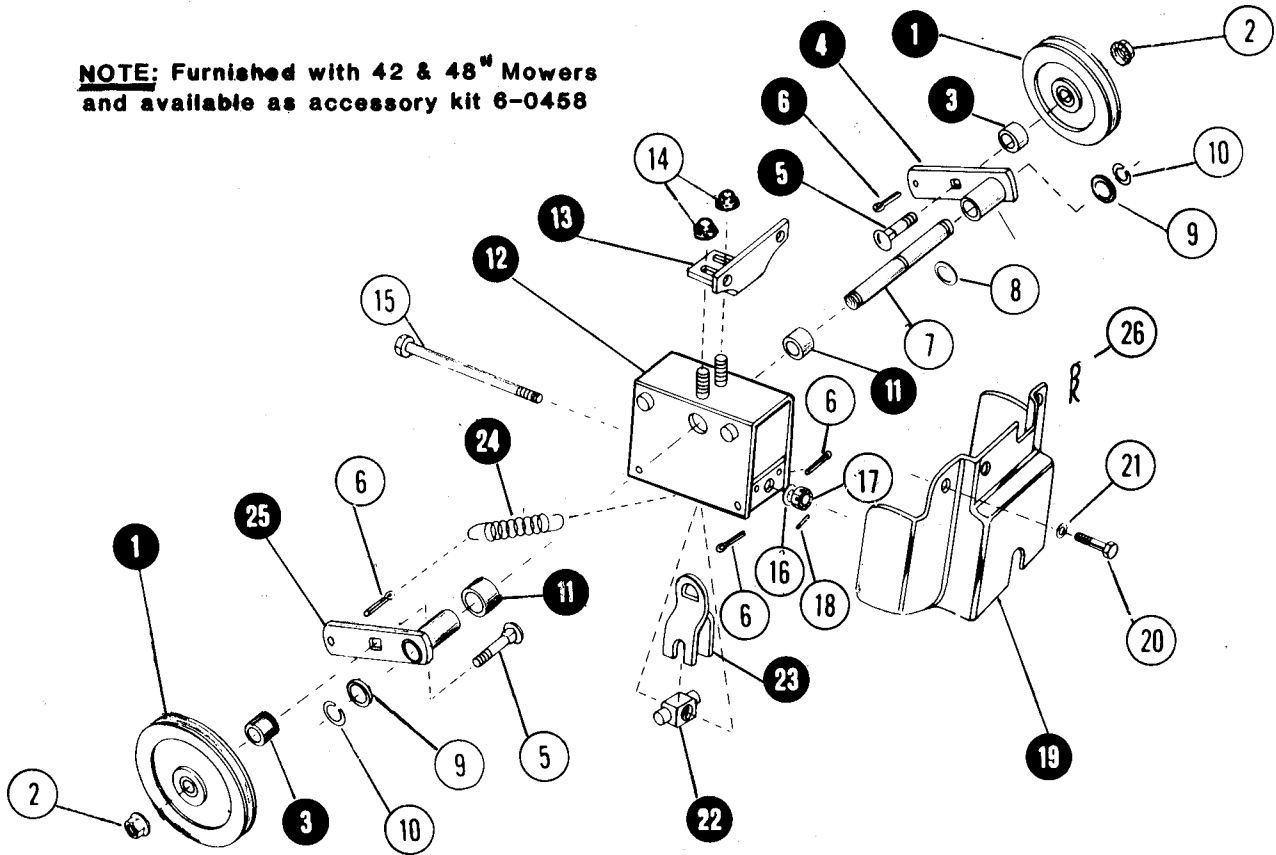

ITEM	PART NO.	DESCRIPTION
1	1-8274	PULLEY, IDLER
2	9-0619	NUT, 1/2C FLANGE LOCK
3	2-7506	SPACER, PULLEY
4	4-7741	ARM, IDLER PULLEY LEFT SIDE
5	9-0618	BOLT, 1/2C X 2 CARRIAGE
6	9-0616	COTTER-PIN, 1/4 x 3/4
7	2-7508	SHAFT, PULLEY RETAINER
8	1-8272	WASHER, 17/32 x 7/8 x 5/64
9	1-2695	SHIM, .009-.011"
10	1-2696	RING, SHAFT RETAINER
11	2-7504	SPACER, IDLER ARM PULLEY
12	4-9823	FRAME, IMPLEMENT DRIVE
13	3-9624	BRACKET, MOUNTING
14	9-0613	NUT, 3/8C FLANGE LOCK
15	2-7503	BOLT, 3/8C HEX DRILLED
16	9-0122	WASHER, 3/8 FLAT
17	9-0617	NUT, 3/8C HEX SLOTTED
18	1-2694	PIN, SPIROL 3/32 x 9/16
19	1-9532	COVER, IMPLEMENT DRIVE
20	9-0581	BOLT, 5/16C x 7/8 HEX
21	9-0188	WASHER, 5/16 FLAT
22	2-7507	TRUNNION, PULLEY ADJUSTER
23	4-7742	BRACKET, ADJUSTER
24	1-8273	SPRING, IDLER PULLEY TENSION
25	4-7740	ARM, IDLER PULLEY RIGHT SIDE
26	1-2672	HAIR-PIN CLIP

42" MOWER

ATTACHMENT 8-0199

REAR LIFT
LINK PARTS
See Page 9

FRONT LIFT
LINK PARTS
See Page 9

GAUGE WHEELS

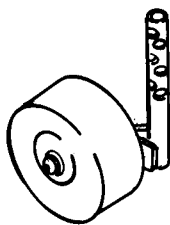

See Page 8

DECALS - See Page 14

42" MOWER

ITEM	PART NO.	DESCRIPTION
1	4-9895	MOWER HOUSING
2	4-9631	COVER, TIMING BELT
3	4-9652	PULLEY, MOWER DRIVE
4	1-9581	BELT DRIVE
5	5-9574	PULLEY, TIMING BELT - RIGHT & LEFT SIDE
6	1-9580	BELT, DECK BLADE TIMING
7	5-9573	PULLEY, CENTER TIMING BELT
8	4-9628	BRACKET, BELT ADJUSTING
9	1-8345	SPRING, BELT ADJUSTER
10	4-9621	ROD, BELT ADJUSTING
11	3-9904	CHUTE, MOWER SIDE DISCHARGE
12	1-2801	PIN, SPIROL
13	2-7560	SPACER, PULLEY
14	2-7561	SPACER, LEFT SIDE PULLEY
15	1-2800	RING, RETAINING
16	1-9572	BEARING, BALL
17	2-9528	SHAFT, LEFT SIDE SPINDLE
18	2-9527	SHAFT, CENTER SPINDLE
19	2-9526	SHAFT, RIGHT SIDE SPINDLE
20	1-8344	RING, RETAINING
21	1-9586	HOUSING, SPINDLE
22	1-8410	BEARING, NEEDLE
23	1-9643	SEAL, OIL
24	4-7757	MOUNTING, CUTTING BLADE
25	1-2799	PIN, BLADE MOUNTING SHEAR
26	1-9879	BLADE MOWER CUTTING
27	9-0491	BOLT, 1/2C x 1-1/4 HEX HEAD
28	9-0254	WASHER, 1/2 SPLIT LOCK
29	1-8341	WASHER, BLADE TO SPINDLE CONE
30	9-0664	BOLT, 3/8C x 1-1/8 CARRIAGE
31	9-0613	NUT, 3/8C HEX FLANGE LOCK
32	9-0582	BOLT, 3/8C x 1 HEX FLANGE LOCK
33	9-0122	WASHER, 3/8 FLAT
34	3-2031	SHIM, .030" (AS REQUIRED)
-	3-2030	SHIM, .060" (AS REQUIRED)
35	9-0595	BOLT, 5/16C x 3/4 HEX FLANGE LOCK
36	9-0585	NUT, 5/16C HEX FLANGE LOGK
37	9-0504	NUT, 3/8C HEX
38	9-0665	NUT, 3/8C HALF HEX
39	9-0666	BOLT, 1/4C x 3/8 CARRIAGE
40	9-0583	NUT, 1/4C HEX FLANGE LOCK

48" MOWER

ATTACHMENT 8-0299

REAL LIFT
LINK PARTS
See Page 9

FRONT LIFT
LINK PARTS
See Page 9

GAUGE WHEELS

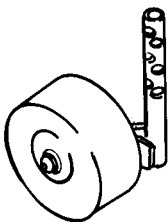

See Page 8

DECALS - See Page 14

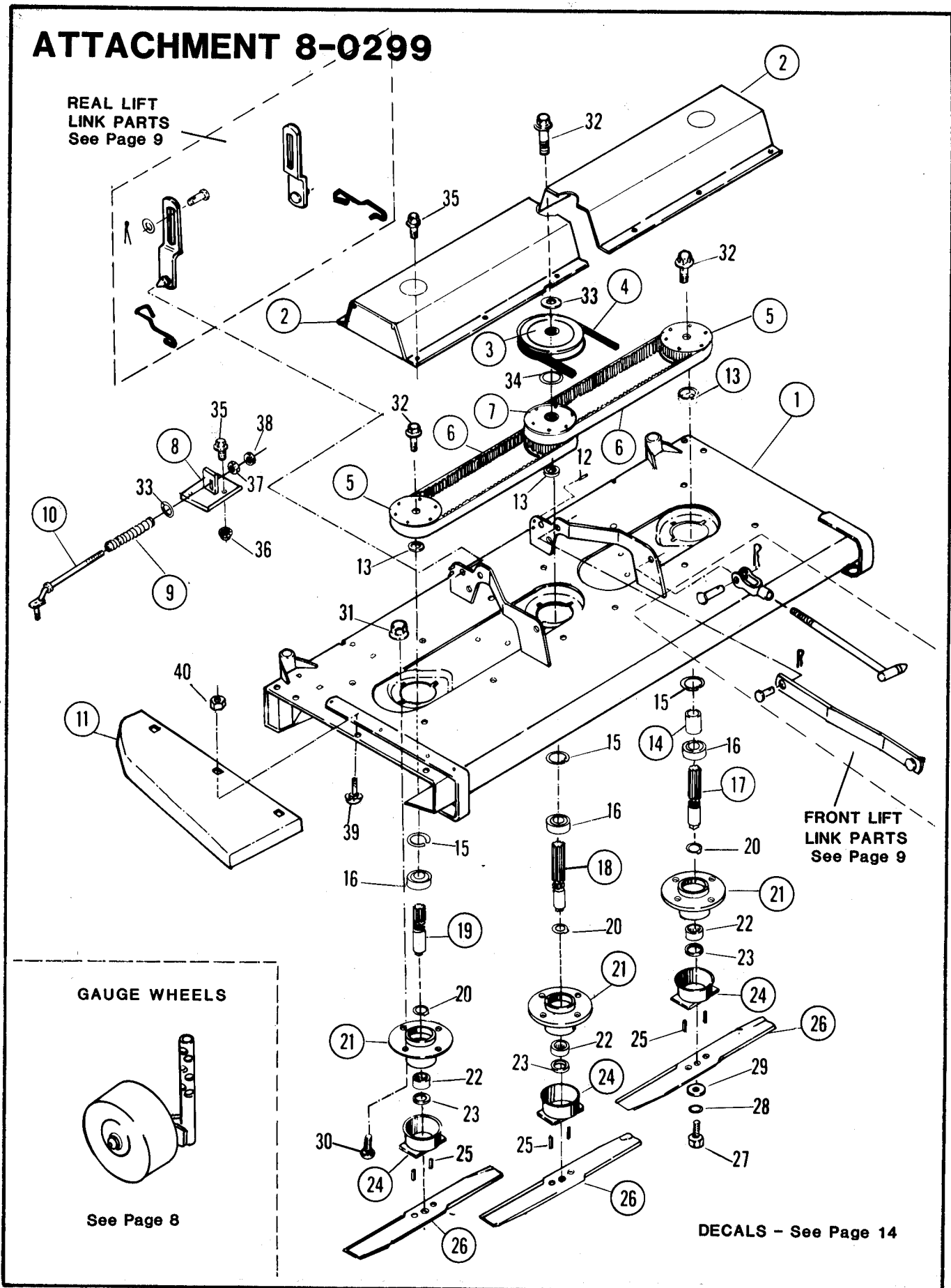

48" MOWER

ITEM	PART NO.	DESCRIPTION
1	4-9874	MOWER HOUSING
2	4-9624	COVER, TIMING BELT
3	4-9653	PULLEY, MOWER DRIVE
4	1-9581	BELT, MULE DRIVE
5	5-9574	PULLEY, TIMING BELT - RIGHT & LEFT SIDE
6	1-9594	BELT, DECK BLADE TIMING
7	5-9573	PULLEY, CENTER TIMING BELT
8	4-9628	BRACKET, BELT ADJUSTING
9	1-8345	SPRING, BELT ADJUSTER
10	4-9621	ROD, BELT ADJUSTING
11	3-9897	CHUTE, MOWER SIDE DISCHARGE
12	1-2801	PIN, SPIROL
13	2-7560	SPACER, PULLEY
14	2-7561	SPACER, LEFT SIDE PULLEY
15	1-2800	RING, RETAINING
16	1-9572	BEARING, BALL
17	2-9528	SHAFT, LEFT SIDE SPINDLE
18	2-9527	SHAFT, CENTER SPINDLE
19	2-9526	SHAFT, RIGHT SIDE SPINDLE
20	1-8344	RING, RETAINING
21	1-9586	HOUSING, SPINDLE
22	1-8410	BEARING, NEEDLE
23	1-9643	SEAL, OIL
24	4-7757	MOUNTING, CUTTING BLADE
25	1-2799	PIN, BLADE MOUNTING SHEAR
26	1-9880	BLADE, MOWER CUTTING
27	9-0491	BOLT, 1/2 x 1-1/4 HEX HEAD
28	9-0254	WASHER, 1/2 SPLIT LOCK
29	1-8341	WASHER, BLADE TO SPINDLE CONE
30	9-0664	BOLT, 3/8C x 1-1/8 CARRIAGE
31	9-0613	NUT, 3/8C HEX FLANGE LOCK
32	9-0582	BOLT, 3/8C x 1 HEX FLANGE LOCK
33	9-0122	WASHER, 3/8 FLAT
34	3-2031	SHIM, .030" (AS REQUIRED)
-	3-2030	SHIM, .060" (AS REQUIRED)
35	9-0595	NUT, 5/16C HEX FLANGE LOCK
36	9-0585	NUT, 5/16C HEX FLANGE LOCK
37	9-0504	NUT, 3/8C HEX
38	9-0665	NUT, 3/8C HALF HEX
39	9-0666	BOLT, 1/4C x 3/8 CARRIAGE
40	9-0583	NUT, 1/4C HEX FLANGE LOCK

GAUGE WHEELS

ALL MOWERS

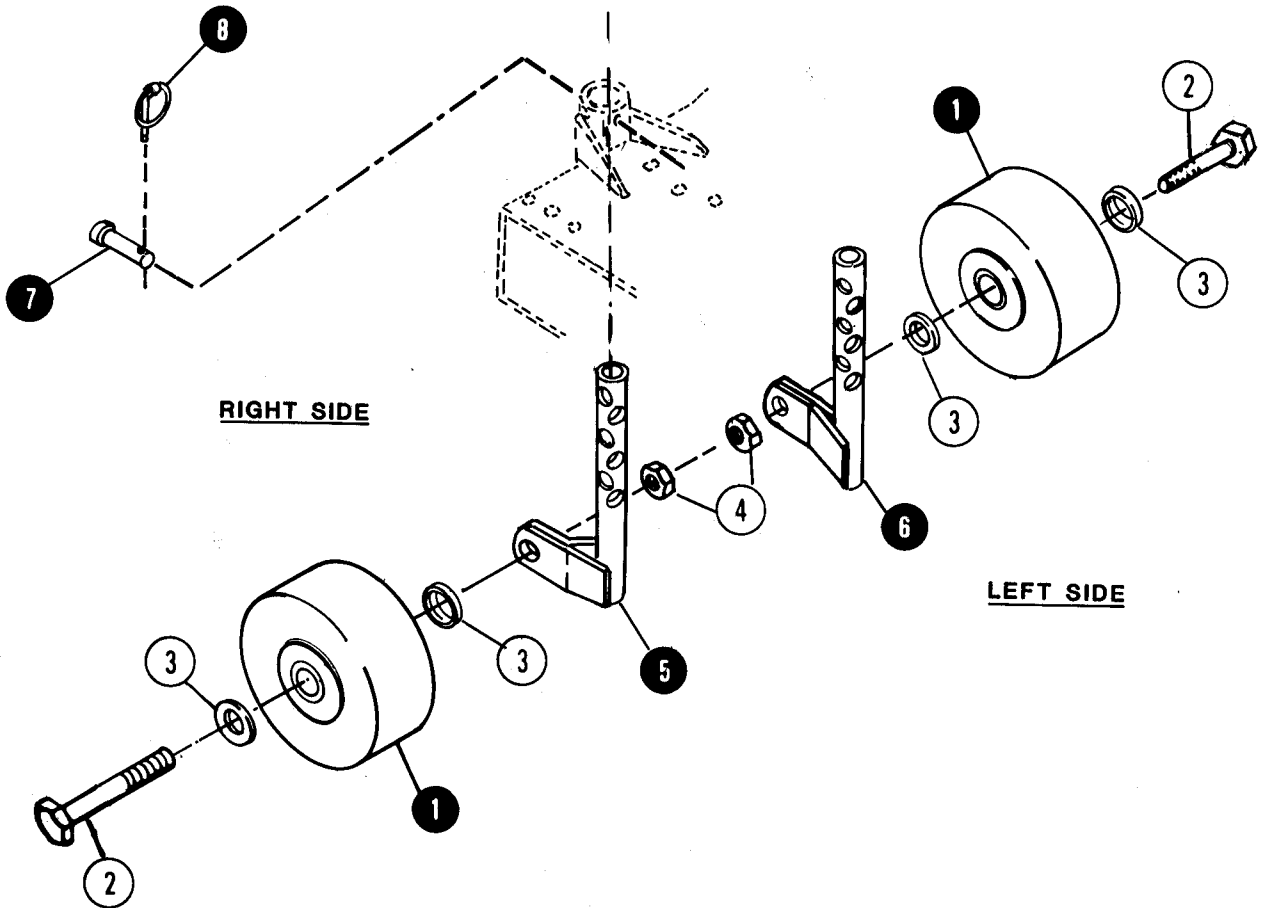

ITEM	PART NO.	DESCRIPTION
1	1-8445	WHEEL, GAUGE (ALL MOWERS)
2	9-0748	BOLT, 1/2C x 3-1/2 HEX HEAD
3	1-8348	CUP-WASHER, GAUGE WHEEL
4	9-0258	NUT, 1/2C HEX
5	4-9861	SPINDLE, WHEEL - RIGHT SIDE (FOR 42" & 48" MOWER)
-	4-9870	SPINDLE, WHEEL - RIGHT SIDE (FOR 54" MOWERS)
6	4-9860	SPINDLE, WHEEL - LEFT SIDE (FOR 42" & 48" MOWERS)
-	4-9866	SPINDLE, WHEEL - LEFT SIDE (FOR 54" MOWERS)
7	1-3323	CLEVIS-PIN, GAUGE WHEEL ADJUSTING
8	1-8339	PIN, KLIK

ALL MOWERS

FRONT & REAR LIFT LINKS

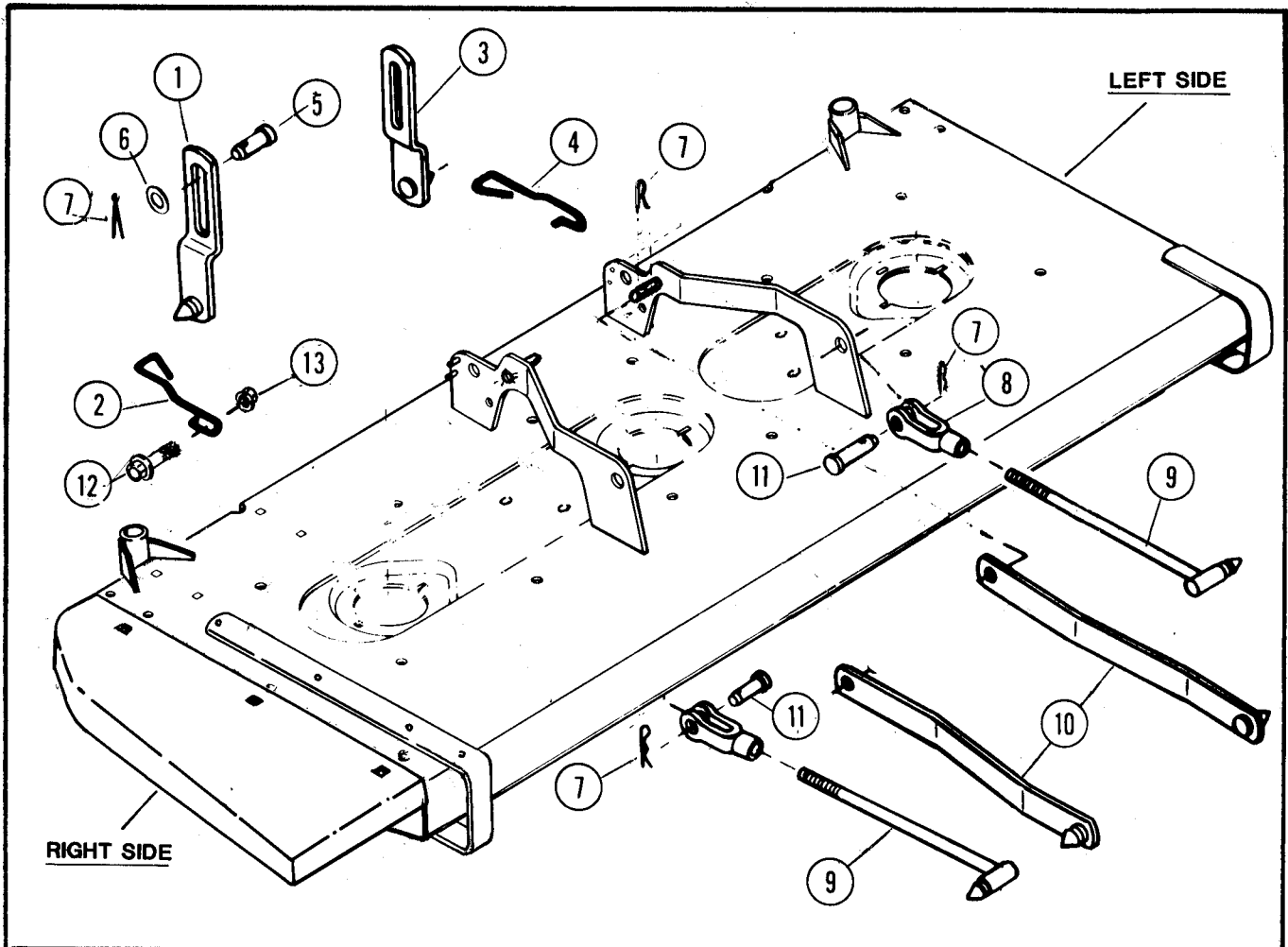

ITEM	PART NO.	DESCRIPTION
1	4-9626	LINK, RIGHT REAR LIFT (42 & 48" MOWERS)
-	4-9620	LINK, RIGHT REAR LIFT (54" MOWERS)
2	1-9589	SPRING, RIGHT LINK TO BRACKET (42 & 48" MOWERS)
-	1-8354	SPRING, RIGHT LINK TO BRACKET (54" MOWERS)
3	4-9626	LINK, LEFT REAR LIFT (42 & 48" MOWERS)
-	4-9622	LINK, LEFT REAR LIFT (54" MOWERS)
4	1-9588	SPRING, LEFT LINK TO BRACKET (42 & 48" MOWERS)
-	1-8354	SPRING, LEFT LINK TO BRACKET (54" MOWERS)
5	1-2802	PIN, LINK TO SHAFT CLEVIS
6	9-0250	WASHER, 1/2" FLAT
7	1-2714	PIN, HAIR CLIP
8	1-2806	YOKE, FRONT LIFT LINK ADJUSTING
9	4-9625	LINK, FRONT LIFT (42 & 48" MOWERS)
-	4-9617	LINK, FRONT LIFT (54" MOWERS)
10	4-9867	LINK, CENTER LIFT (42 & 48" MOWERS)
-	4-9618	LINK, FRONT LIFT (54" MOWERS)
11	1-2803	PIN, YOKE TO MOWER BASE
12	9-0604	BOLT, 1/4C x 7/8 HEX FLANGE LOCK
13	9-0583	NUT, 1/4C HEX FLANGE LOCK

54" MOWER

ATTACHMENT 8-0499

REAR LIFT
LINK PARTS
See Page 9

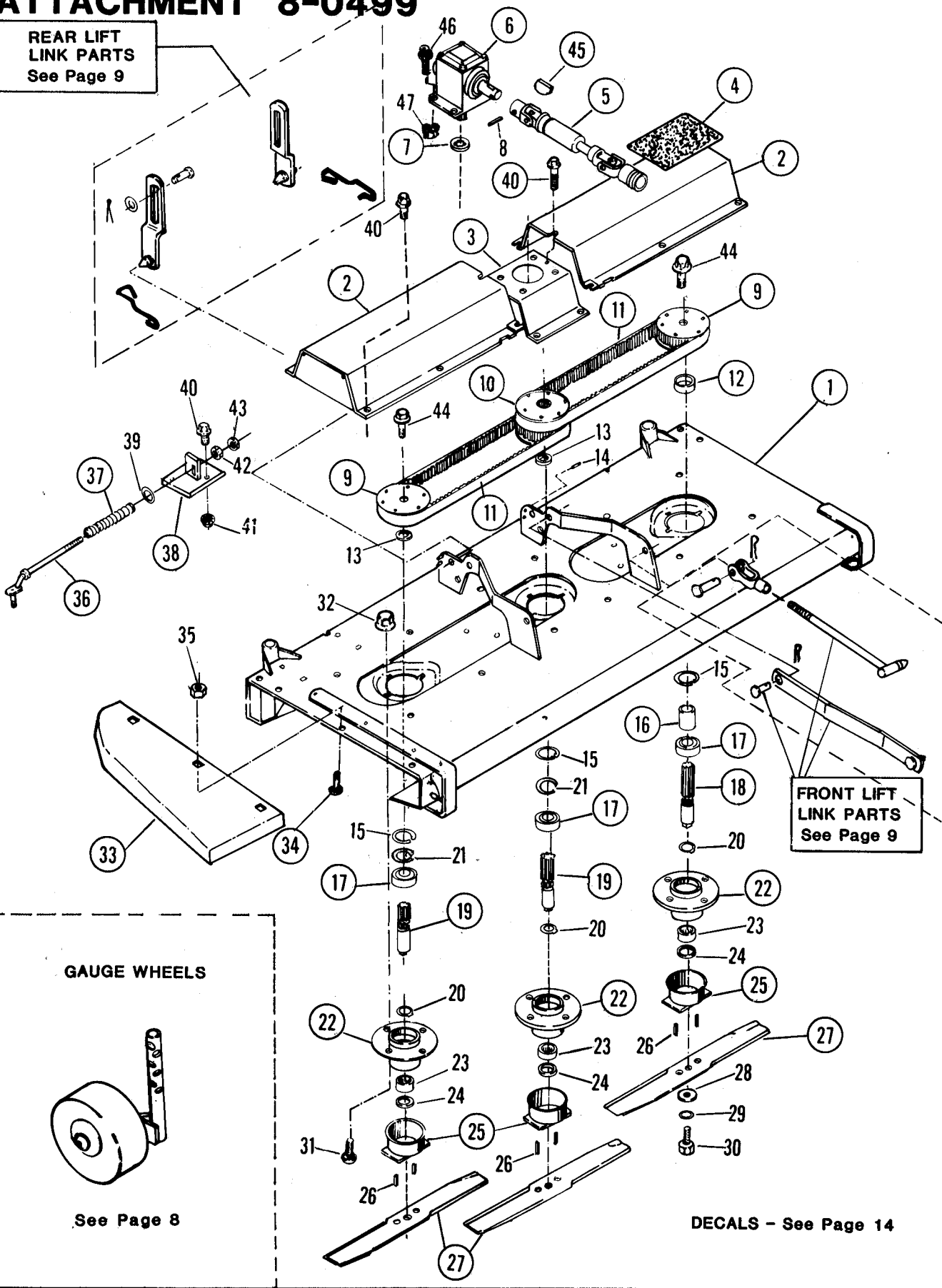

54" MOWER

ITEM	PART NO.	DESCRIPTION
1	4-9868	MOWER HOUSING
2	4-9619	COVER, TIMING BELT (RIGHT & LEFT SIDE)
3	4-9855	SUPPORT, GEAR BOX
4	1-9601	TREAD, STEP
5	1-9882	UNIVERSAL - JOINT ASSEMBLY (SEE PAGES 12 & 13)
6	5-9036	GEAR-BOX ASSEMBLY (SEE PAGES 12 & 13)
7	2-9530	SPACER, SPLINED
8	1-2834	PIN, GROOVE 1/4 x 1-3/4
9	5-9574	PULLEY, TIMING BELT (RIGHT & LEFT SIDE)
10	5-9573	PULLEY, TIMING BELT CENTER
11	1-9578	BELT, DECK BLADE TIMING
12	2-7560	SPACER, LEFT SIDE PULLEY
13	2-7567	SPACER, RIGHT SIDE & CENTER PULLEY
14	1-2801	PIN, HOUSING SPIROL
15	1-2800	RING, RETAINING
16	2-7561	SPACER, LEFT SIDE PULLEY (LOWER)
17	1-9572	BEARING, BALL x
18	2-9544	SHAFT, LEFT SIDE SPINDLE (6" LONG)
19	2-9533	SHAFT, CENTER & RIGHT SIDE SPINDLE (4-3/4" LONG)
20	1-8344	RING, RETAINING
21	1-2833	RING, RETAINING
22	1-9586	HOUSING, SPINDLE
23	1-8410	BEARING, NEEDLE
24	1-9643	SEAL, OIL
25	4-7757	MOUNTING, CUTTING BLADE
26	1-2799	PIN, BLADE MOUNTING (SHEAR)
27	1-9883	BLADE, MOWER CUTTING
28	1-8341	WASHER, BLADE TO SPINDLE CONE
29	9-0254	WASHER, 1/2 SPLIT LOCK
30	9-0491	BOLT, 1/2C X 1-1/4 HEX HEAD
31	9-0664	BOLT, 3/8C x 1-1/8 CARRIAGE
32	9-0613	NUT, 3/8C HEX FLANGE LOCK
33	3-9881	CHUTE, MOWER SIDE DISCHARGE
34	9-0666	BOLT, 1/4C x 3/8 CARRIAGE
35	9-0583	NUT, 1/4C HEX FLANGE LOCK
36	4-9621	ROD, BELT ADJUSTING
37	1-8345	SPRING, BELT ADJUSTER.
38	4-9628	BRACKET, BELT ADJUSTING
39	9-0122	WASHER, 3/8 FLAT
40	9-0595	BOLT, 5/16C x 3/4 HEX FLANGE LOCK
41	9-0585	NUT, 5/16C HEX FLANGE LOCK
42	9-0504	NUT, 3/8C HEX
43	9-0665	NUT, 3/8C HALF HEX
44	9-0582	BOLT, 3/8C x 1 HEX FLANGE LOCK
45	1-2684	KEY, WOODRUFF
46	9-0587	BOLT, 3/8-16 x 1-1/4 HEX HEAD
47	9-0613	NUT, 3/8-16 HEX FLANGE LOCK

54" MOWER

GEAR BOX & U-JOINT

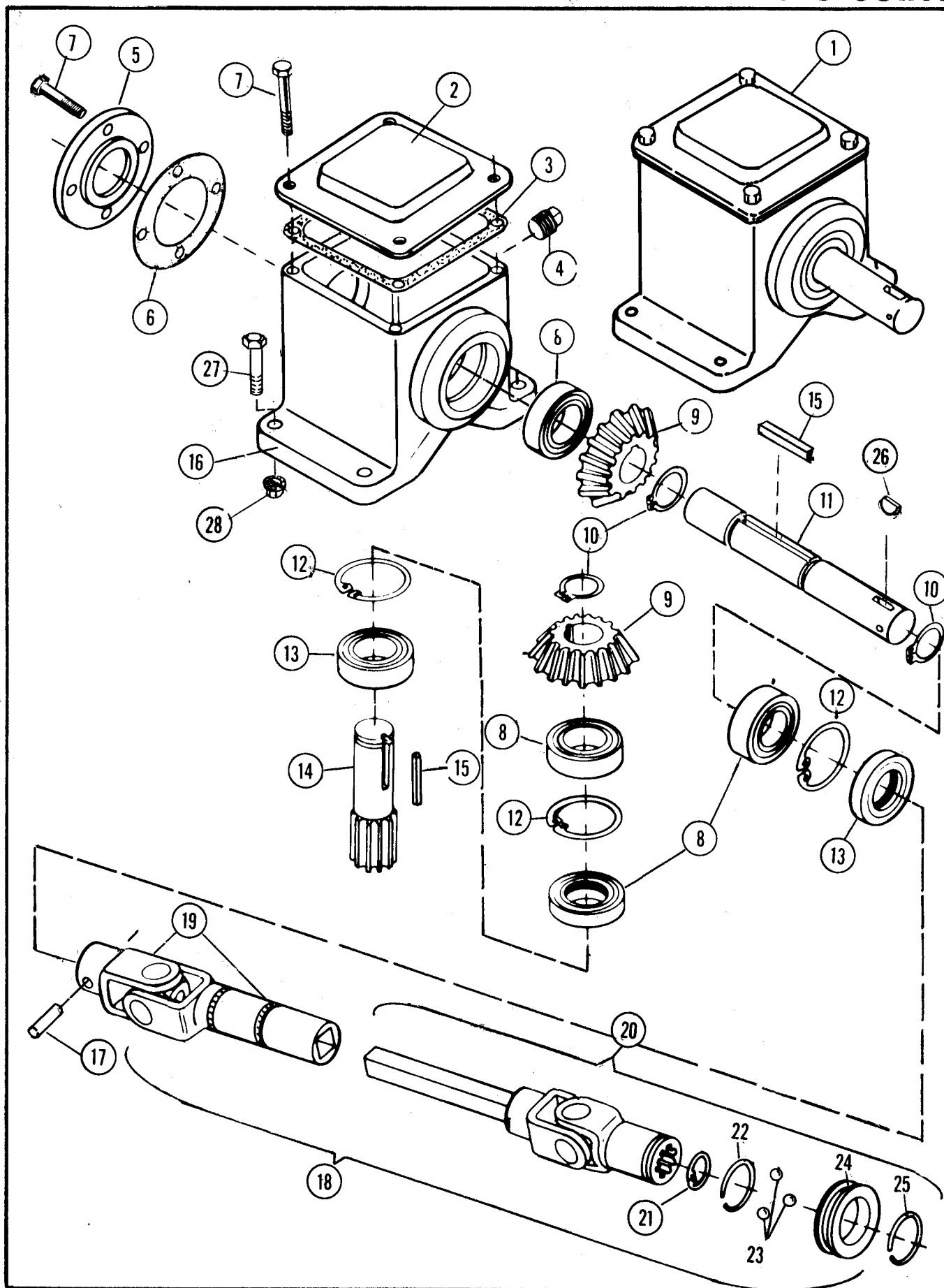

GEAR BOX & U-JOINT

54" MOWER

ITEM	PART NO.	DESCRIPTION
1	5-0936	GEAR BOX ASSEMBLY (INCLUDES ITEMS 2 THRU 16)
2	3-7869	COVER, GEAR BOX (TOP)
3	1-8329	GASKET, COVER
4	1-2832	PLUG, 1/2" P.T.
5	1-8352	COVER, GEAR BOX (SIDE)
6	3-7870	SHIM, SIDE COVER (AS REQUIRED)
7	9-0580	BOLT, 1/4" x 3/4 HEX HEAD (8)
8	1-2828	BEARING, BALL (4)
9	1-9597	PINION-GEAR (2)
10	1-2829	RING, RETAINING (3)
11	2-1816	SHAFT, GEAR BOX INPUT
12	1-2827	RING, RETAINING (3)
13	1-9598	SEAL, OIL (2)
14	2-9531	SHAFT, GEAR BOX OUTPUT
15	1-2830	KEY, STRAIGHT
16	1-9881	HOUSING, GEAR BOX
17	1-2834	PIN, GROOVE 1/4 x 1-3/4
18	1-9882	UNIVERSAL JOINT ASSEMBLY (INCLUDES ITEMS 19 THRU 25)
19	1-3829	JOINT & TUBE ASSEMBLY
20	1-3827	JOINT & SHAFT ASSEMBLY (INCLUDES ITEMS 21 THRU 25)
21	1-3828	RING, RETAINING
22	1-8361	RING, SPRING RETAINING
23	1-2854	BALL, 3/8" DIAMETER (3)
24	1-9609	COLLAR, LOCK
25	1-8362	RING, RETAINING
26	1-2684	KEY, WOODRUFF
27	9-0587	BOLT, 3/8-16 x 1-1/4 HEX HEAD
28	9-0613	NUT, 3/8-16 HEX FLANGE LOCK

KITS, MID-MOUNT IMPLEMENT BRACKET

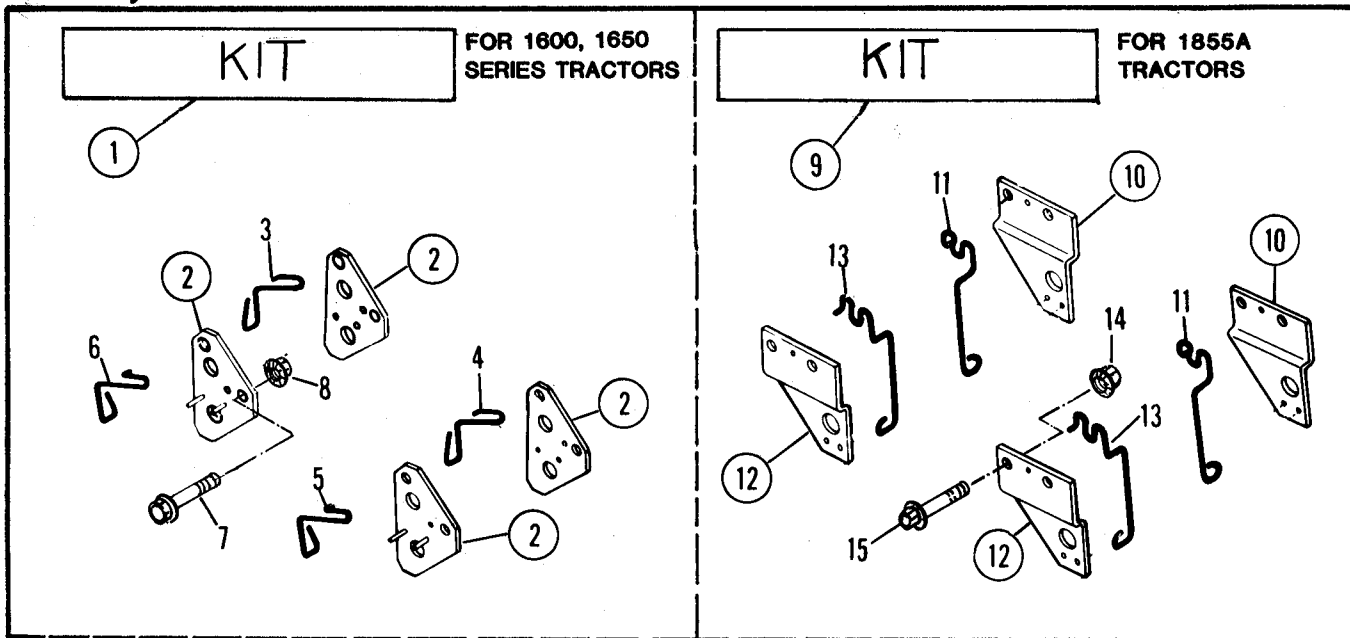

NOTE: MOUNTING BRACKETS FURNISHED ON TRACTORS BUT ALSO AVAILABLE IN KIT FORM

ITEM	PART NO.	DESCRIPTION
1	6-0448	KIT, IMPLEMENT MTG. (INCLUDES ITEMS 2 THRU 8)
2	5-9554	BRACKET, LINK PIVOT (4)
3	1-9591	SPRING, LEFT REAR
4	1-9593	SPRING, LEFT FRONT
5	1-9590	SPRING, RIGHT FRONT
6	1-9592	SPRING, RIGHT REAR
7	9-0661	BOLT, 5/16-18 x 1 HEX FLANGE LOCK (8)
8	9-0585	NUT, 5/16-18 HEX LOCK (8)
9	6-0453	KIT, IMPLEMENT MTG. (INCLUDES ITEMS 10 THRU 15)
10	5-9549	BRACKET, LEFT SIDE LINK PIVOT (2)
11	1-9599	SPRING, LEFT SIDE (2)
12	5-9550	BRACKET, RIGHT SIDE LINK PIVOT (2)
13	1-9600	SPRING, RIGHT SIDE (2)
14	9-0587	BOLT, 3/8-16 x 1-1/4 HEX HEAD (8)
15	9-0613	NUT, 3/8-16 HEX FLANGE LOCK (8)

DECALS

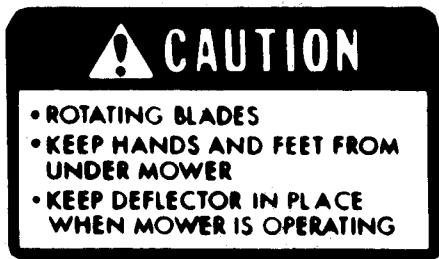

#1-8338



#1-9582

Parts Manual for

SNAPPER[®]

GARDEN TRACTOR MOWER ATTACHMENTS

SNAPPER POWER EQUIPMENT

McDonough, Georgia 30253

A Division of Fuqua Industries



PARTS MANUAL #06006 1-80 Issue

PRINTED IN U.S.A.

Free Manuals Download Website

<http://myh66.com>

<http://usermanuals.us>

<http://www.somanuals.com>

<http://www.4manuals.cc>

<http://www.manual-lib.com>

<http://www.404manual.com>

<http://www.luxmanual.com>

<http://aubethermostatmanual.com>

Golf course search by state

<http://golfingnear.com>

Email search by domain

<http://emailbydomain.com>

Auto manuals search

<http://auto.somanuals.com>

TV manuals search

<http://tv.somanuals.com>